

# Technical Drawings for the Mission Video Cabinet

---

Walt Akers - 1998

**Table 1: Cabinet Components, Dimensions and Materials**

<i>Component / Location</i>	<i>Req</i>	<i>Length</i>	<i>Width</i>	<i>Thickness</i>	<i>Material</i>
Cabinet Top Plank / Top	4	49	6.5	3/4	White Oak
Side Crown Molde / Crown	2	25 1/2	2 3/8	3/4	White Oak
Front Crown Molde / Crown	1	47 3/4	2 3/8	3/4	White Oak
Stretcher / Carcasse Top - Shelf Fronts	4	41	1.5	1	White Oak
Shelves / Carcasse	2	41.75	21.75	3/4	Oak Plywood
Side Rails / Carcasse	6	49.5	1.5	1	White Oak
Side Panels / Carcasse	8	49.5	5 1/8	3/4	White Oak
Side Base Mould / Base	2	23.75	6.5	3/4	White Oak
Front Base Mould / Base	1	44.5	6.5	3/4	White Oak
Door Rail / Door	4	33	3	3/4	White Oak
Door Center Rail / Door	2	25	3	3/4	White Oak
Door Top Stile / Door	2	16	3	3/4	White Oak
Door Bottom Stile / Door	2	16	5	3/4	White Oak
Door Panel / Door	4	24.75	6.75	1/2	White Oak
Door Spacer Bar / Left Door	1	33	1.0	3/4	White Oak
Door Spacer Backing / Left Door	1	33	2.25	1/2	White Oak
Drawer Front / Drawer	1	41	7	3/4	White Oak
Drawer Side / Drawer	2	22	6	1/2	Oak Plywood
Drawer Back / Drawer	1	39.5	5 3/8	1/2	Oak Plywood
Drawer Bottom / Drawer	1	39.5	21.75	1/4	Oak Plywood
Cabinet Back / Carcasse	1	41 3/4	42 3/8	1/4	Oak Plywood

# Assembled Entertainment Cabinet

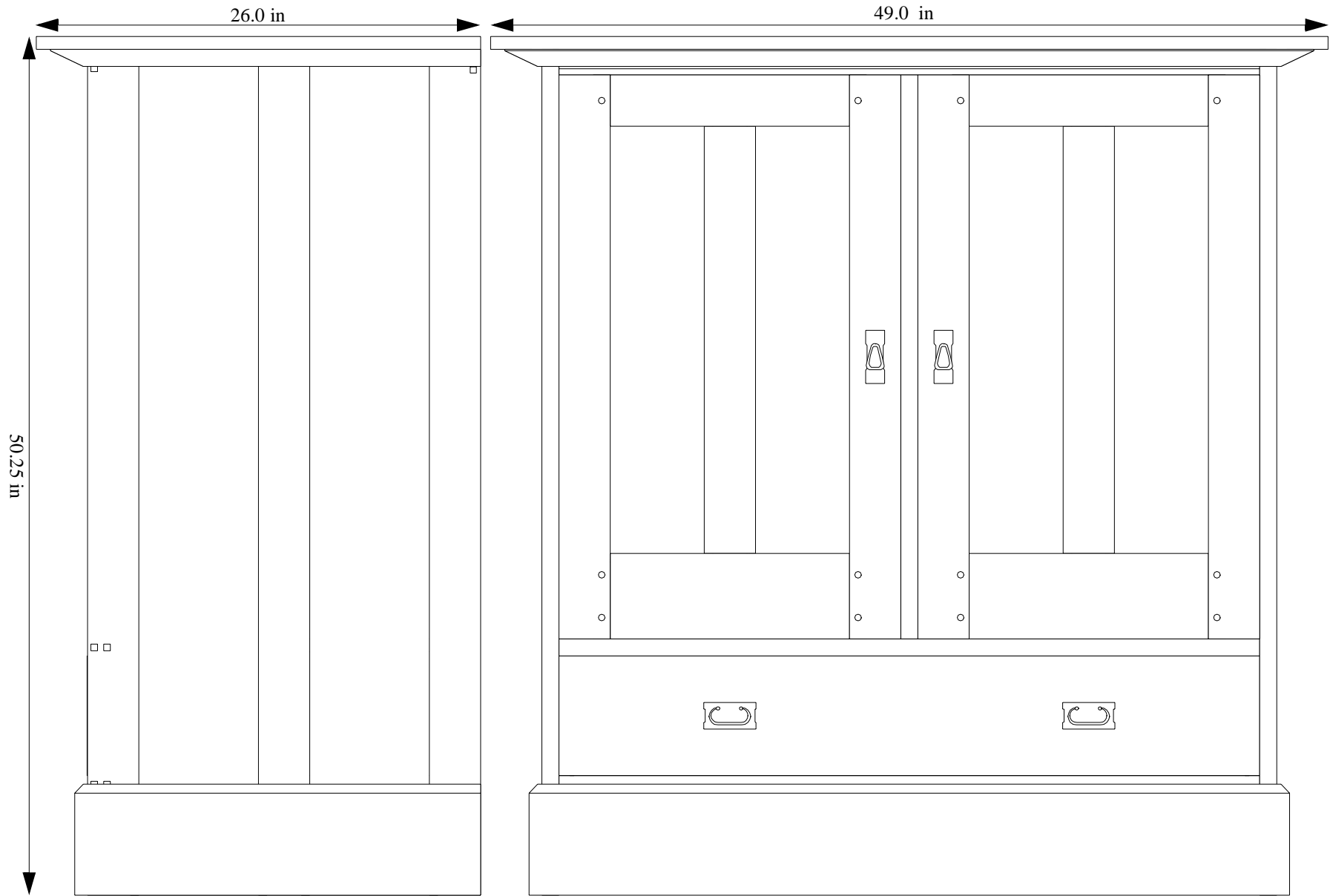

# Components of the Cabinet Top - Option 2

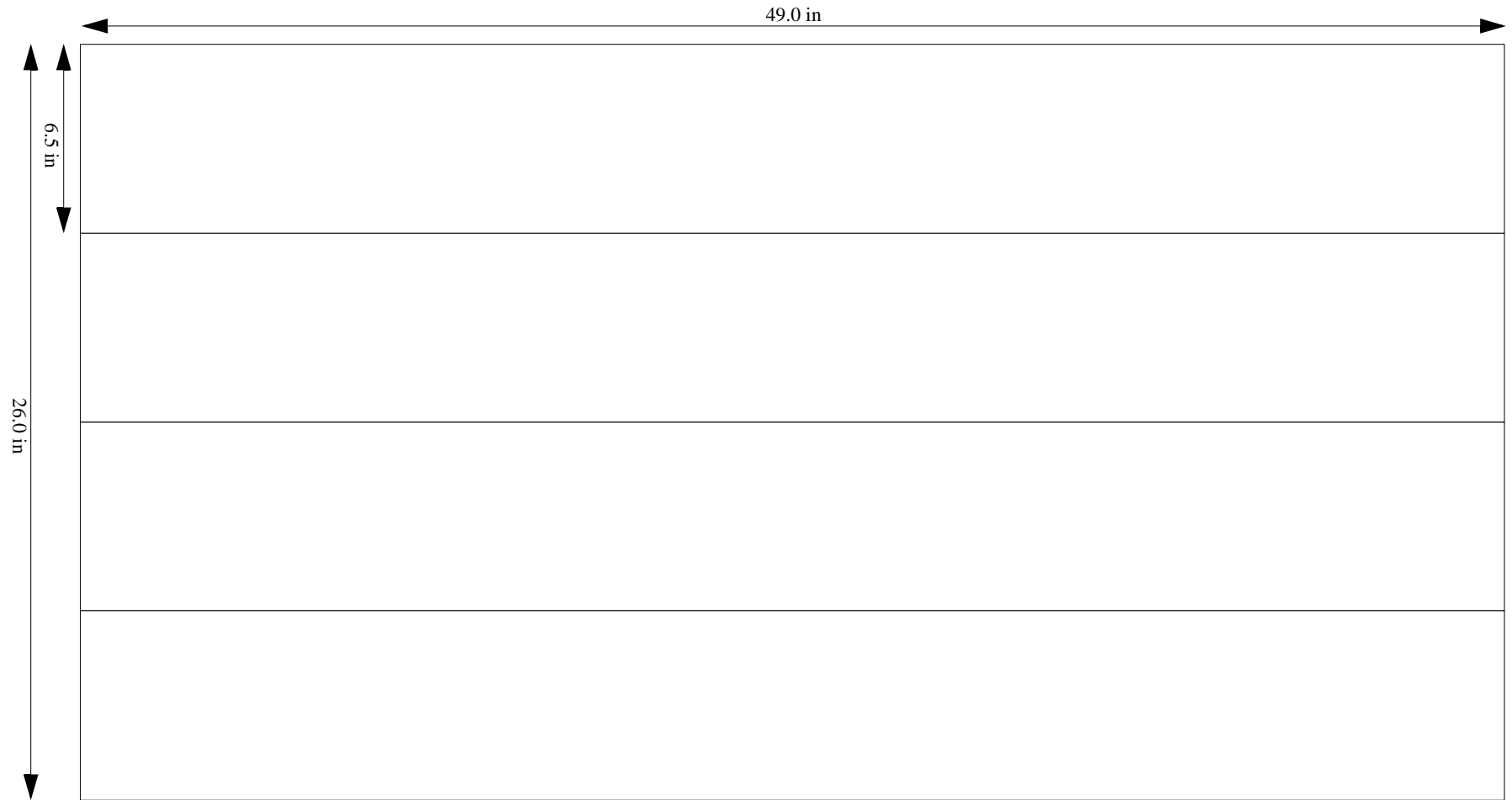

## Construction of the Cabinet Top

### Millwork:

- 1 Cut, plane and joint four boards to the following dimensions.  
A One (1) at 49" x 6 1/2" x 3/4".

### Assembly:

- 1 Lay boards side by side, and rotate them to alternate their growth rings.
- 2 Align the left edge of all four boards and draw a registration mark at 2 inches from this edge.

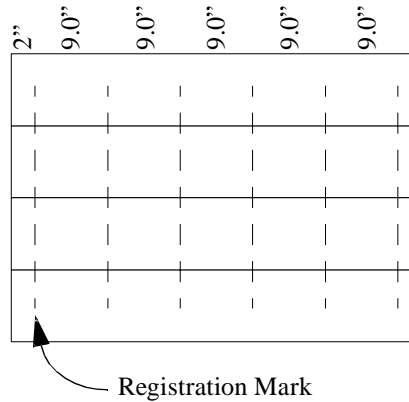

- 3 Repeat 5 additional registration marks every 9 inches. These marks indicate where the biscuit slots will be cut.
- 4 Using the biscuit cutter, install number twenty biscuits slots at each registration point.
- 5 Install biscuits and glue and clamp work piece together.

# Crown Molding and Cabinet Top Stiles

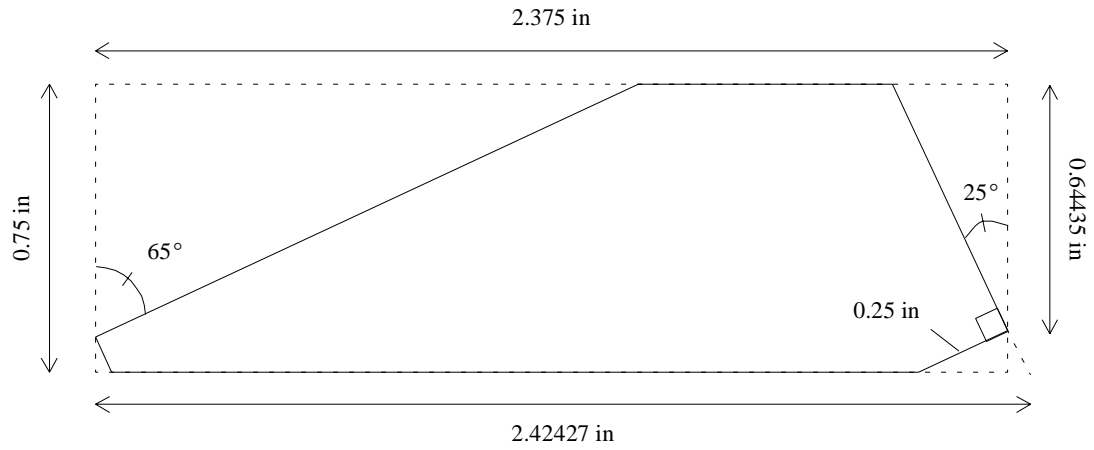
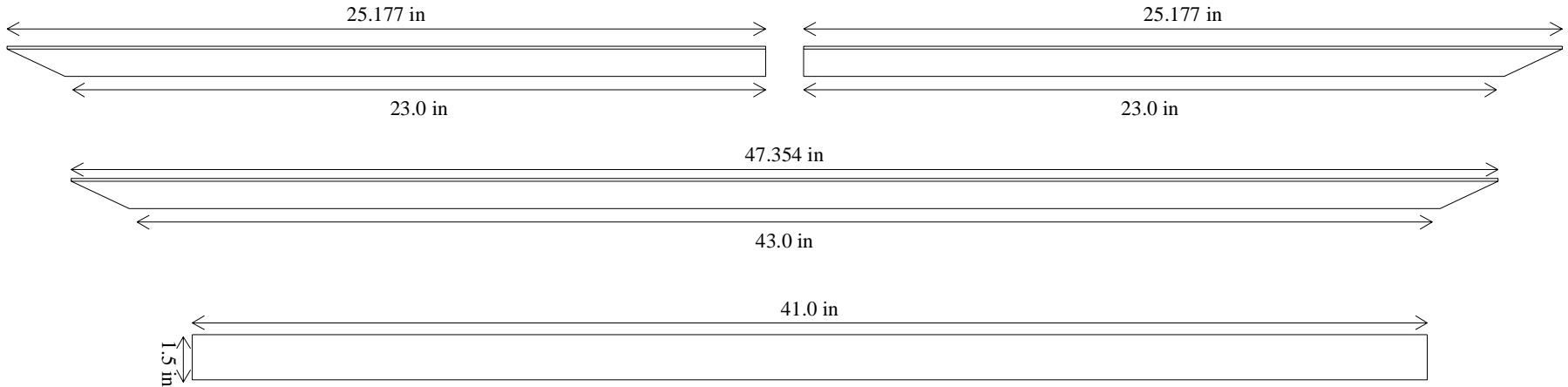

## Construction of the Crown Molding

### Millwork:

- 1 Cut, plane and joint three sections of white oak to the following dimensions.
  - A Two (2) at  $25 \frac{1}{2}'' \times 2 \frac{3}{8}'' \times \frac{3}{4}''$
  - B One (1) at  $48'' \times 2 \frac{3}{8}'' \times \frac{3}{4}''$
- 2 Set the tablesaw bevel to 25 degrees.
- 3 Position the fence  $2 \frac{7}{16}''$  to the left of the blade.
- 4 Placing the  $2 \frac{3}{8}''$  side of each board against the table, rip the  $\frac{3}{4}''$  side to 25 degrees.
- 5 Position the fence  $\frac{1}{8}''$  to the right of the blade.
- 6 Placing the uncut  $\frac{3}{4}''$  side of each board against the table, bevel the  $2 \frac{3}{8}''$  side. Use featherboards as necessary to keep the board tight against the fence.
- 7 Return the blade to 0 degrees bevel.
- 8 Attach a sacrificial strip to the tablesaw fence and position the fence against the blade.
- 9 Cut the remaining edges of the workpiece.
- 10 Do not cut the 45 degree angles on these pieces until the carcass has been completed and measured.

### Assembly:

No independent assembly is required of these components.

## Construction of the Cabinet Top Stretchers

### Millwork:

- 1 Cut, plane and joint two sections of white oak to the following dimensions.
  - A Two (2) at  $41'' \times 1 \frac{1}{2}'' \times \frac{3}{4}''$

### Assembly:

No independent assembly is required of these components.

# Components of the Cabinet Base

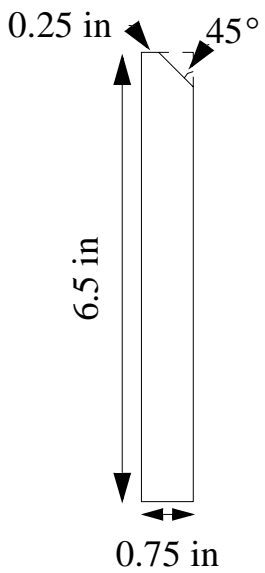
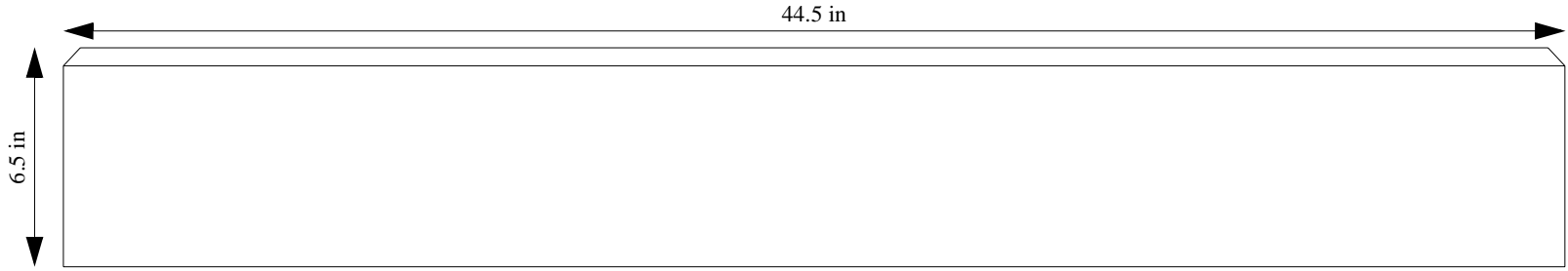
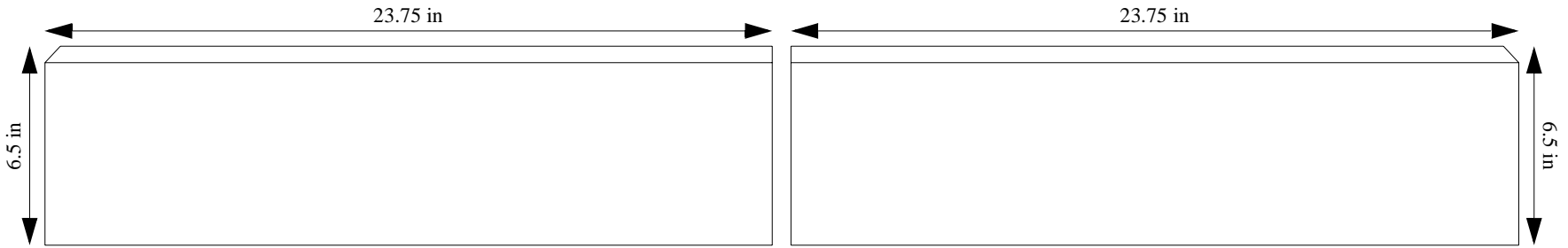



## Construction of the Base Molding

### Millwork:

- 1 Cut, plane and joint three sections of white oak to the following dimensions.
  - A Two (2) at  $24\frac{1}{2}'' \times 6\frac{1}{2}'' \times \frac{3}{4}''$
  - B One (1) at  $45\frac{1}{2}'' \times 6\frac{1}{2}'' \times \frac{3}{4}''$
- 2 Set the tablesaw bevel to 45 degrees.
- 3 Position the fence 6'' to the right of the blade.
- 4 Placing the 6.5'' side of the board against the table, chamfer one edge of each board.
- 5 Do not cut the 45 degree joint angles on these pieces until the carcass has been completed and measured.

### Assembly:

No independent assembly is required of these components.

# Components of Right Cabinet Side

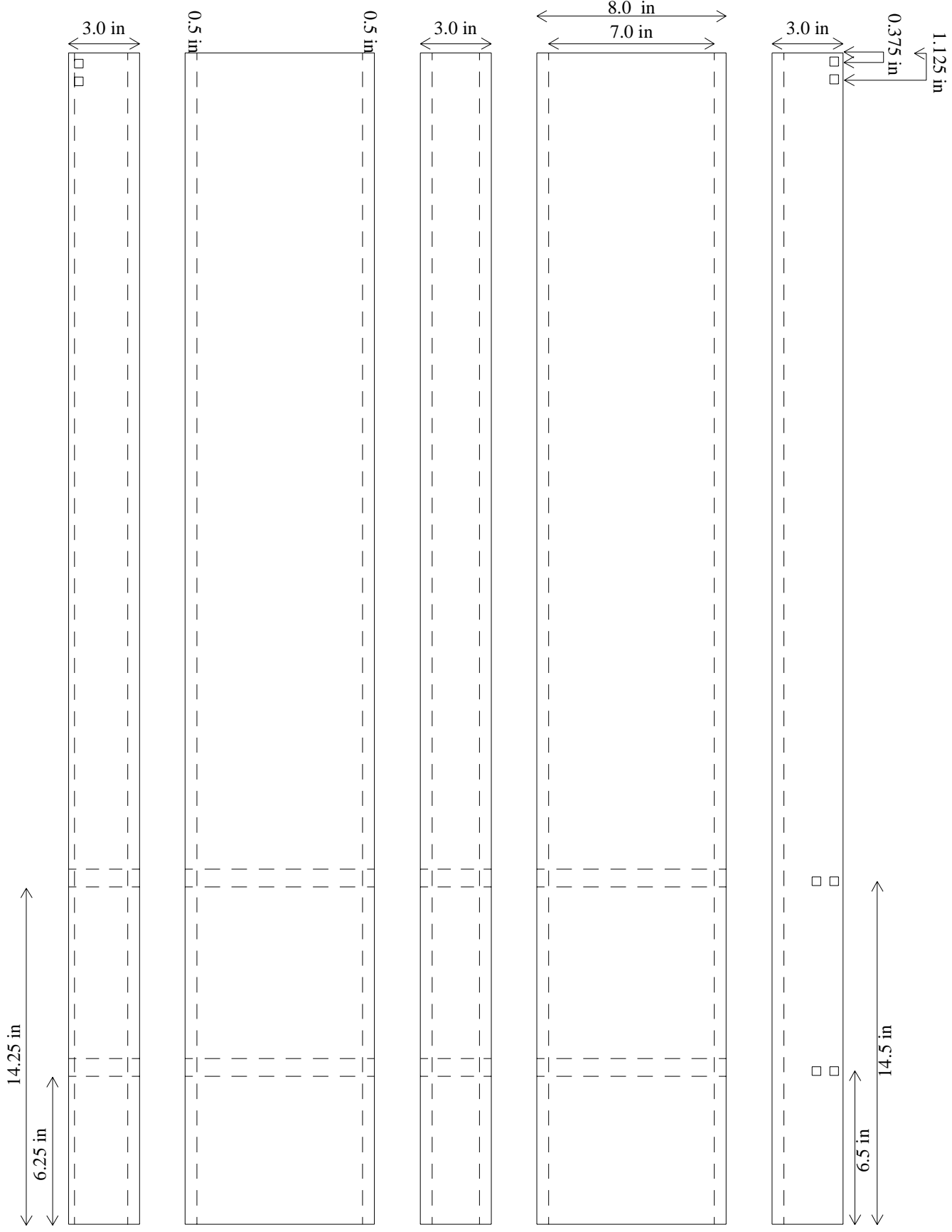

# Components of Left Cabinet Side

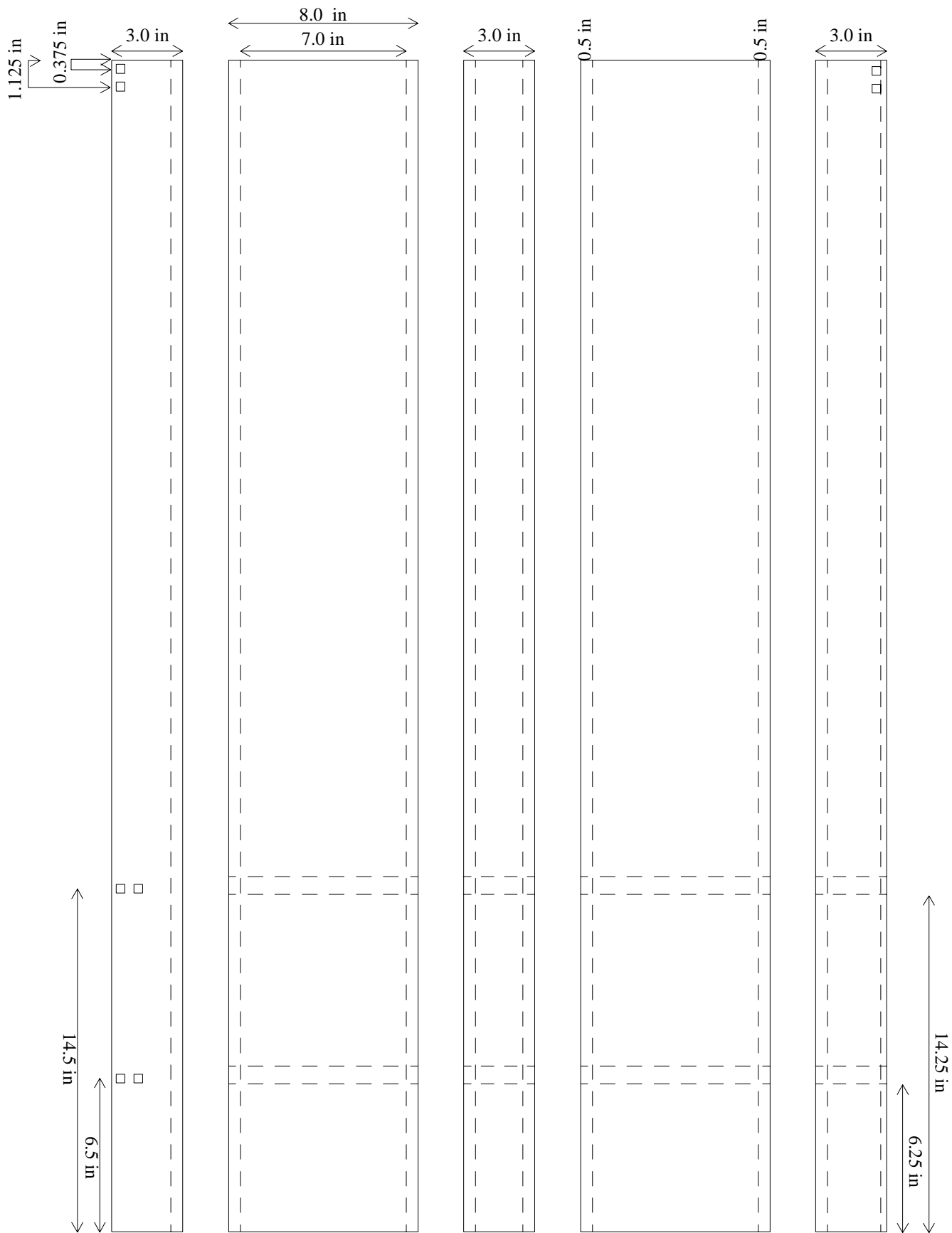

# Components of the Cabinet Shelves

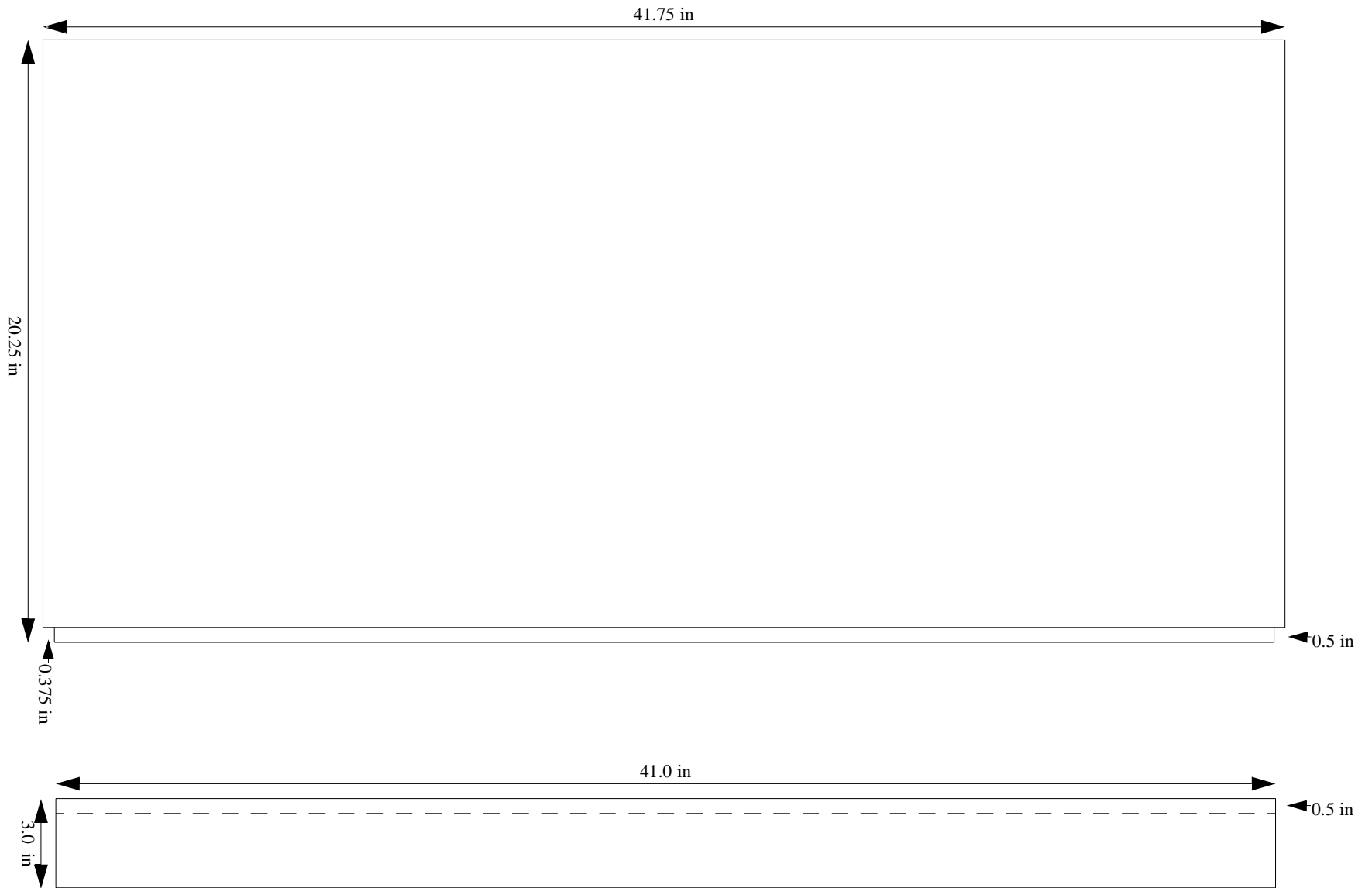

# Cabinet Door Assembly

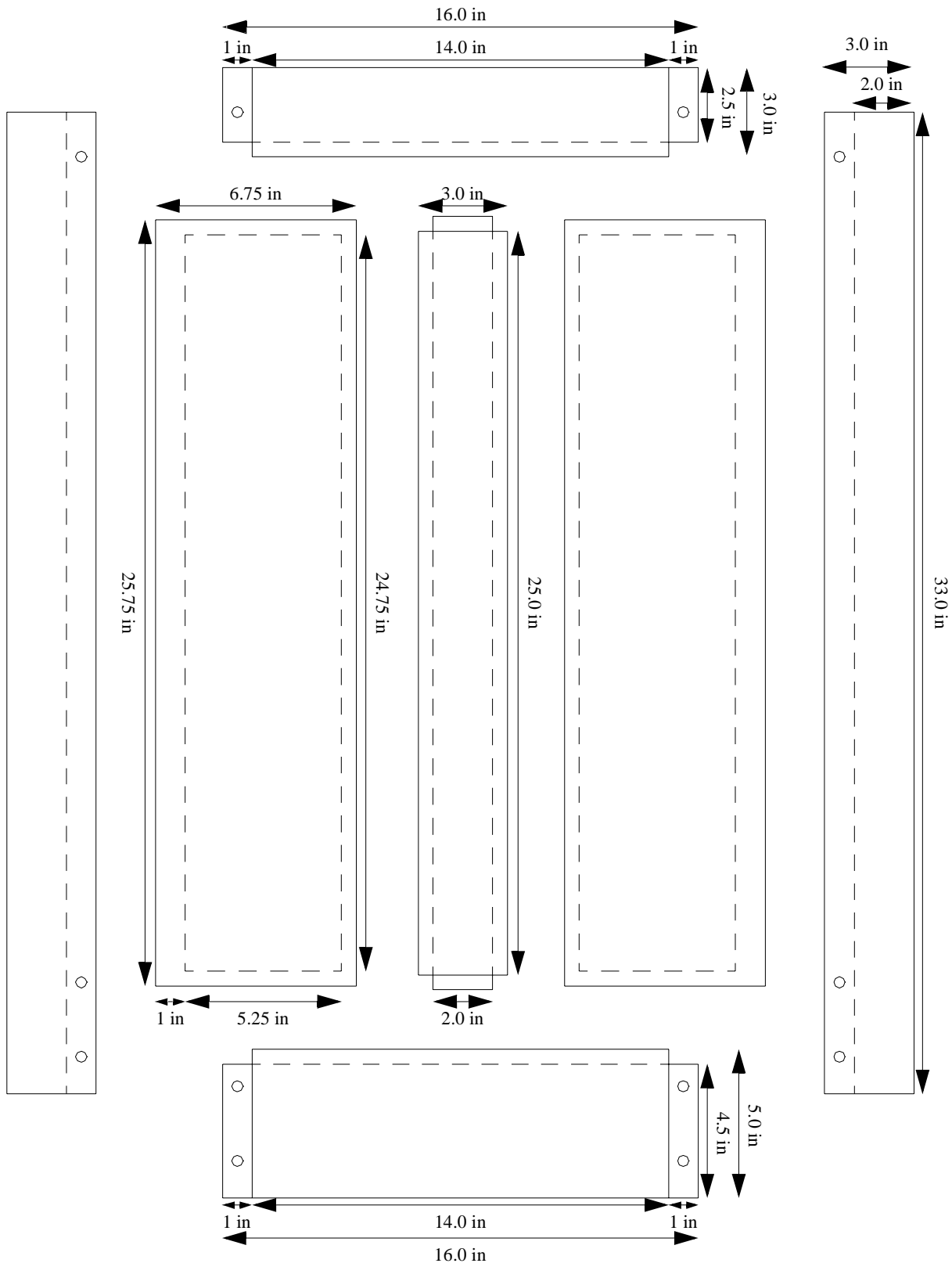

# Door Spacer Assembly

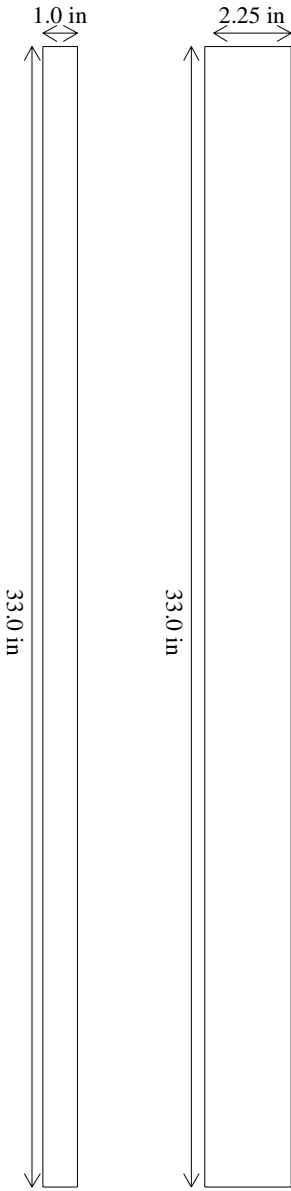

# Drawer Bottom

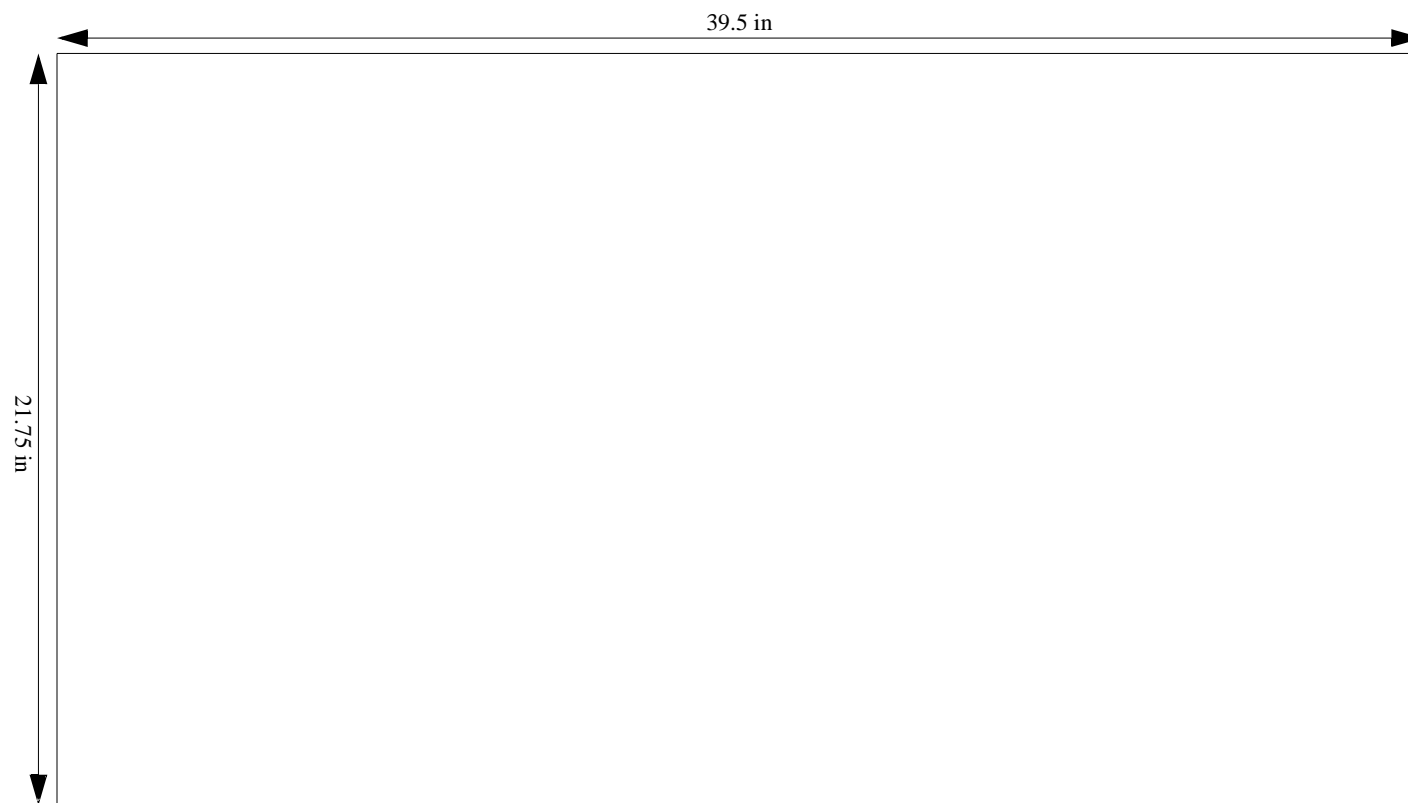

# Drawer Sides and Front

