

Schedule of Materials: Garden Swing

No.	Ltr.	Item	Dimensions T W L	Material
1	A	Bottom back rail	1 1/2" x 5" x 55"	Cedar
2	B	Back stiles	1 1/2" x 2 1/2" x 20 7/8"	Cedar
1	C	Top back rail	1 1/2" x 8" x 60"	Cedar
11	D	Back slats	5/8" x 2 1/2" x 20 1/2"	Cedar
2	E	Seat rails	1 1/2" x 3" x 60"	Cedar
4	F	Seat stringers	1 1/2" x 3" x 17"	Cedar
21	G	Seat slats	5/8" x 2 1/2" x 20"	Cedar
2	H	Arms	1 1/4" x 3" x 23 1/2"	Cedar
2	I	Arm supports	1 1/2" x 4" x 12"	Cedar
2	J	Table battens	3/4" x 1 1/2" x 19 7/8"	Cedar
2	K	Table legs	1" x 1 1/4" x 6 1/2"	Cedar
2	L	Table legs	1" x 1 1/4" x 8 1/4"	Cedar
2	M	Table leg braces	5/8" x 1 1/4" x 13"	Cedar
2	N	Table support cleats	1" x 2" x 20"	Cedar

*Longest slat, cut to fit. **Length oversize to allow fitting.

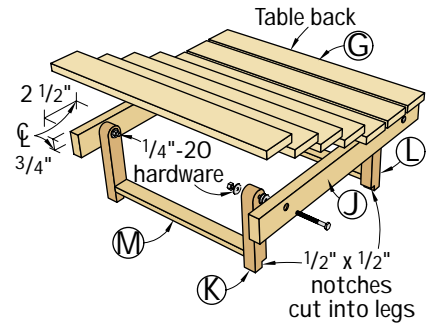
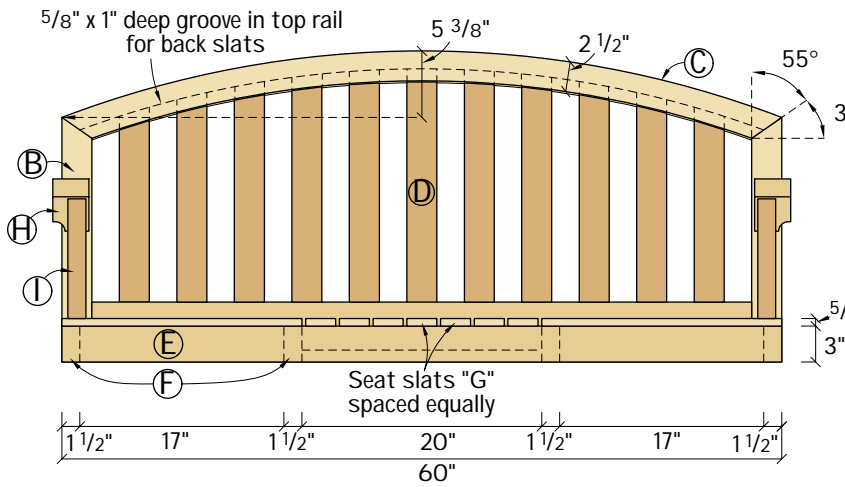

Schedule of Materials: Swing A-Frame

No.	Item	Dim. T W L	Material
4	Frame legs	4 x 4 x 96"	PTP
1	Top center rail	4 x 4 x 96"	PTP
2	Top outer rails	2 x 4 x 96"	PTP
2	Leg supports	2 x 6 x 48"	PTP
4	Swing-N-Slide EZ Frame Braces		
4	Swing-N-Slide Leg top braces		
2	3/8" x 6" eye bolts		
4	3/8" flat washers		
4	3/8" nuts		
8	S-connectors		
4	6-foot lengths of chain		

PTP = pressure treated pine

