

## THE FINISHING TOUCH

While Cedar can be left unfinished for a rustic weathered look, the use of a quality finish recommended by your building supply dealer can enhance both its good looks and its natural characteristics.

Red Cedar accepts a wide range of stains in your choice of tinted transparent finishes for a natural effect, or lightly pigmented semi-transparent finishes. The latter are available in a spectrum of colors.

Look for a coating that offers good fungicide and ultra-violet shielding properties as well as additional preservatives to protect your project's youthful complexion. Varnishes and other film-forming coatings which can crack and peel are not recommended for use on Cedar.

### CHECK FOR ALL OUR "BUILD IT RIGHT WITH TODAY'S CEDAR" BROCHURES:

- Decks, Stairs & Railings
- Gazebos & Outbuildings
- Fences & Gates
- Planter Boxes, Benches & Tables
- Arbors, Trellises & Pergolas
- Garden Obelisks

### TODAY'S CEDAR OFFERS YOU EXTRA ASSURANCE:

The Western Red Cedar Lumber Association mark of quality tells you it's Today's Cedar, carefully manufactured and strictly graded for your intended use.



Western Red Cedar Lumber Association  
 1200 - 555 Burrard Street, P.O. Box 275  
 Vancouver, British Columbia, Canada V7X 1S7  
 Tel: (604) 684-0266 Fax: (604) 687-4930  
 Website: www.wrcla.org

PRINTED IN CANADA

## URBAN TOTEM

Designer: Bill Weber, Artwood Design

Artist Bill Weber used a northwest coast totem pole motif for his obelisk, which has carved panels depicting winter and spring. The birdhouse on top has a removable roof for easy cleaning. Plants can grow up, around and through the structure, or it can be purely a decorative accent. Finish is a semi-transparent exterior stain.

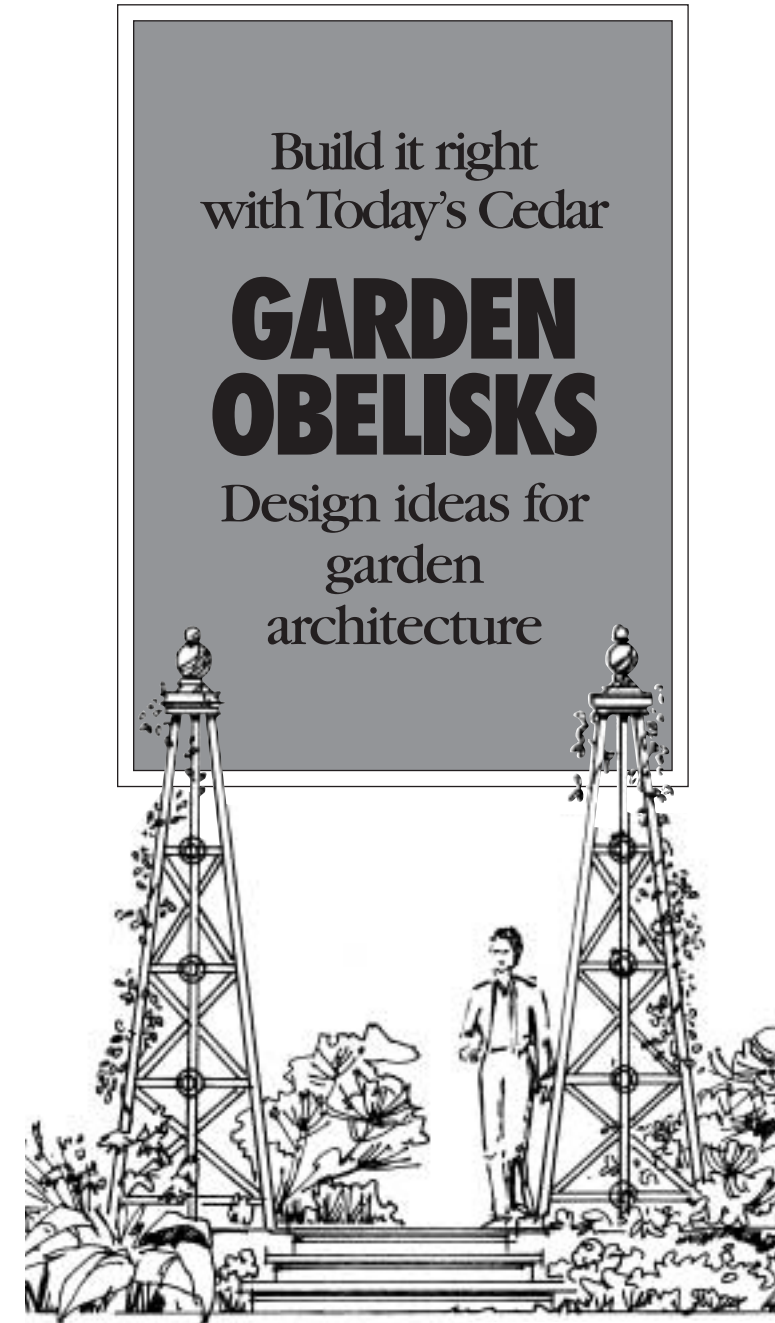
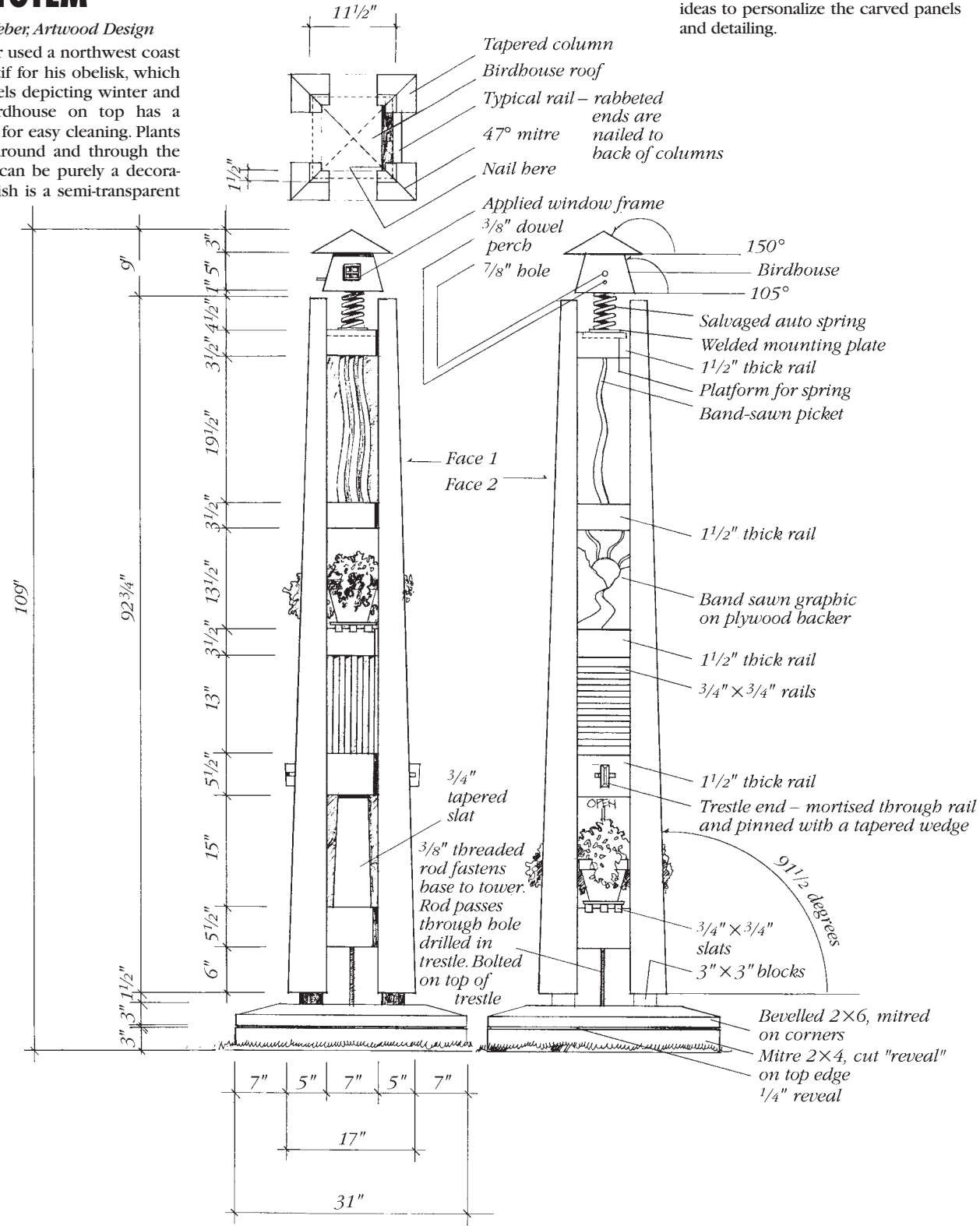

Build it right  
 with Today's Cedar

# GARDEN OBELISKS

Design ideas for  
 garden  
 architecture



## TODAY'S CEDAR FOR YOUR GREAT OUTDOORS

Western Red Cedar is perfectly suited for your outdoor projects. Naturally decay-resistant, light in weight, easy to work, this durable wood is as practical as it is good looking.

This brochure contains helpful pointers on building outdoor Cedar structures for play, entertaining and storage. We have not included step-by-step building instructions as the designs are simply a source of ideas - concepts you can build on to meet your own outdoor living needs.

## CEDAR, NATURALLY

For centuries Western Red Cedar has been the Pacific Northwest's "heritage" outdoor building material - for some very natural reasons:

**Natural durability.** Cedar's natural preservative oil eliminates the need for further chemical treatments, unless the wood is in direct contact with the ground.

**Natural stability.** Cedar resists cracking, warping, cupping and pulling loose from fasteners.

**Natural working ease.** Cedar is uncommonly light in weight, cuts cleanly and easily.

**Natural beauty.** Cedar's richness of grain, color and texture complement any architectural style.

## THREE CEDAR OBELISKS

Created for the WRCLA by three noted designers, these classically inspired cedar garden obelisks are both beautiful and practical. They can be used to support climbing plants, to mark an entry to a garden path or paved entry, or to add structure and architectural character to your garden. Made from durable Western Red Cedar, they are light in weight, easy to move around the garden and will withstand the weather naturally. Secure the bottom feet with stakes to anchor the obelisks into the ground and add your own inspired touches with stain finishes and decorative ornamentation.

## EDWARDIAN STYLE

Designer: Brent Beattie, Southlands Nursery

This formal, Edwardian-style obelisk can be adapted in size for both large gardens with sweeping vistas or small urban patios. Proportion and detailing are everything, says designer Beattie, who suggests finials and metal ornaments as important finishing touches.

Designer's tip: Stain the entire obelisk a natural earth color such as mud gray, gray brown or gray green so that plants and structure are visually integrated.

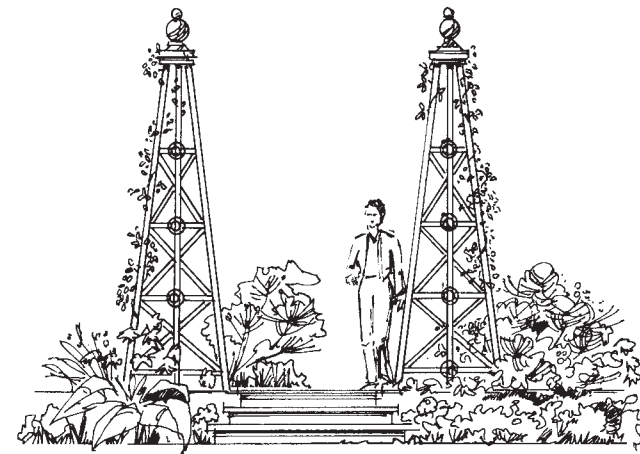
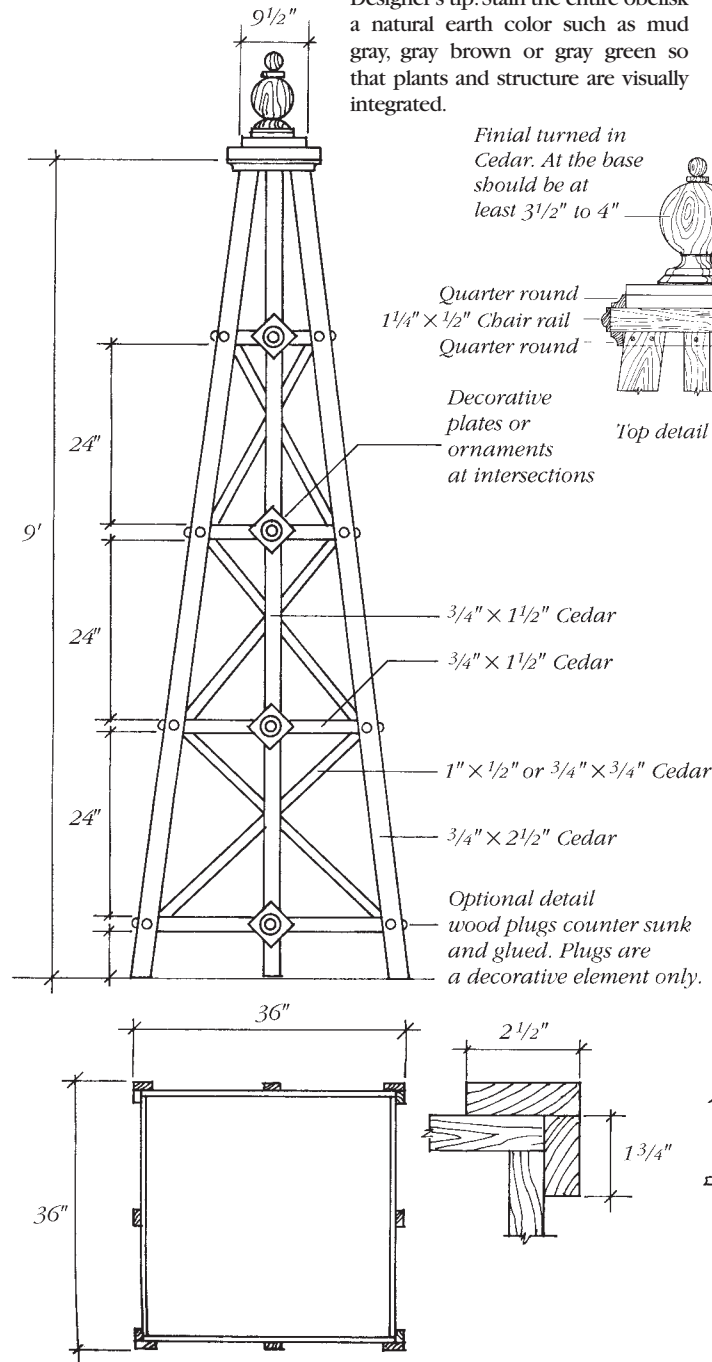

To mark an entrance to a path or different level of garden.

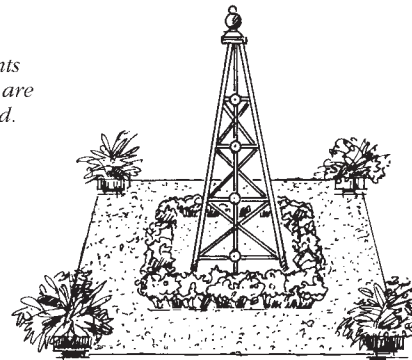

In the middle of a formal bed or "parterre" surrounded by a path.

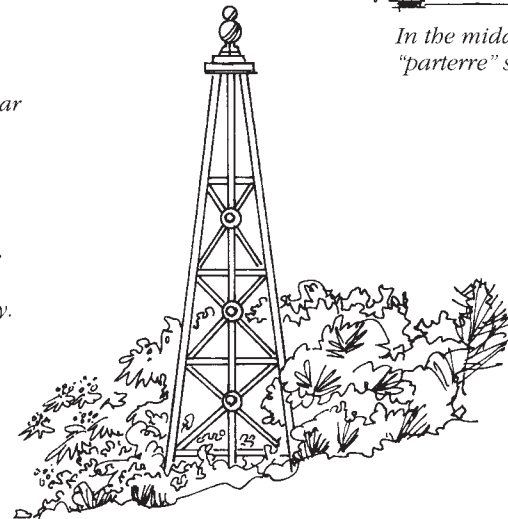

As an architectural feature within a border. Use as a vine support. Adds interest and structure in winter when bed is spare.

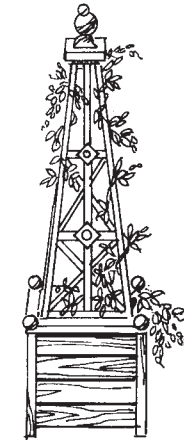

A smaller obelisk can be made to fit in a planter box for growing vines, etc.

## RUSTIC BEAN TOWER

Designer: Barry Marshall, Karo Design Resources

Barry Marshall's backyard bean tower is designed as a simple weekend project that can be built from 5 to 8 feet high to support beans, tomatoes, or other climbing vegetables. Optional versions can be built with cedar lattice or even heavy garden twine.

Designer's tip: Strip the dead vines off the tower at the end of the growing season and leave it out over the winter to add form and dimension to the garden.

