

LEFT SIDE SECTION VIEW

SUGGESTION:  
-INSTALL ALL WIRING BEFORE  
-INSTALLING AIR DUCTS.

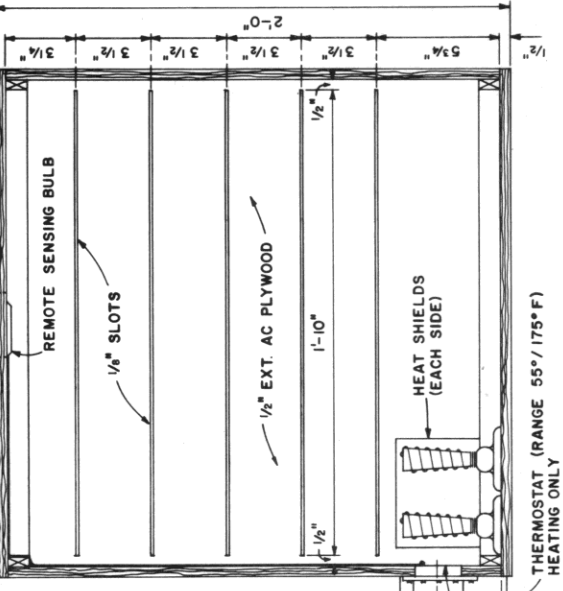

BACK-SECTION VIEW "PLENUM"

CAUTION:  
HEAT SHIELDS MUST BE INSTALLED  
TO MINIMIZE FIRE HAZARD.

- REMOTE SENSING BULB FOR THERMOSTAT
- PLENUM CHAMBER
- REMOVABLE BACK PANEL (LINE WITH ALUM. FOIL)
- 1 KW-110 V. CONE TYPE RESIST HEATING ELEMENTS.
- TWO 5x4x16 GA. SHEET METAL SHIELDS
- 110 V. SURFACE MOUNT PORCELAIN SOCKET

1/4 HP DAYTON MOD. 2C781, 115 V.-2870 RPM-R SO. C. AT 1/2" DIA. FAN MOTOR (CONSTANT RUN)

2 1/8" DIA. INTAKE PORT

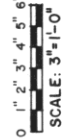

DEVELOPED BY THE FRUIT SUBSTATION,  
CLARKSVILLE, AND THE AGRICULTURAL  
ENGINEERING DEPARTMENT, UNIVERSITY  
OF ARKANSAS, PLAN NO. 731001

COOPERATIVE EXTENSION WORK IN AGRICULTURE AND HOME ECONOMICS	
UNITED STATES DEPARTMENT OF AGRICULTURE COOPERATING	
FRUIT DRIER	
ARK. 74	SHEET 1 OF 3
6202	
TR. 87-1-5	DATE: 7/4

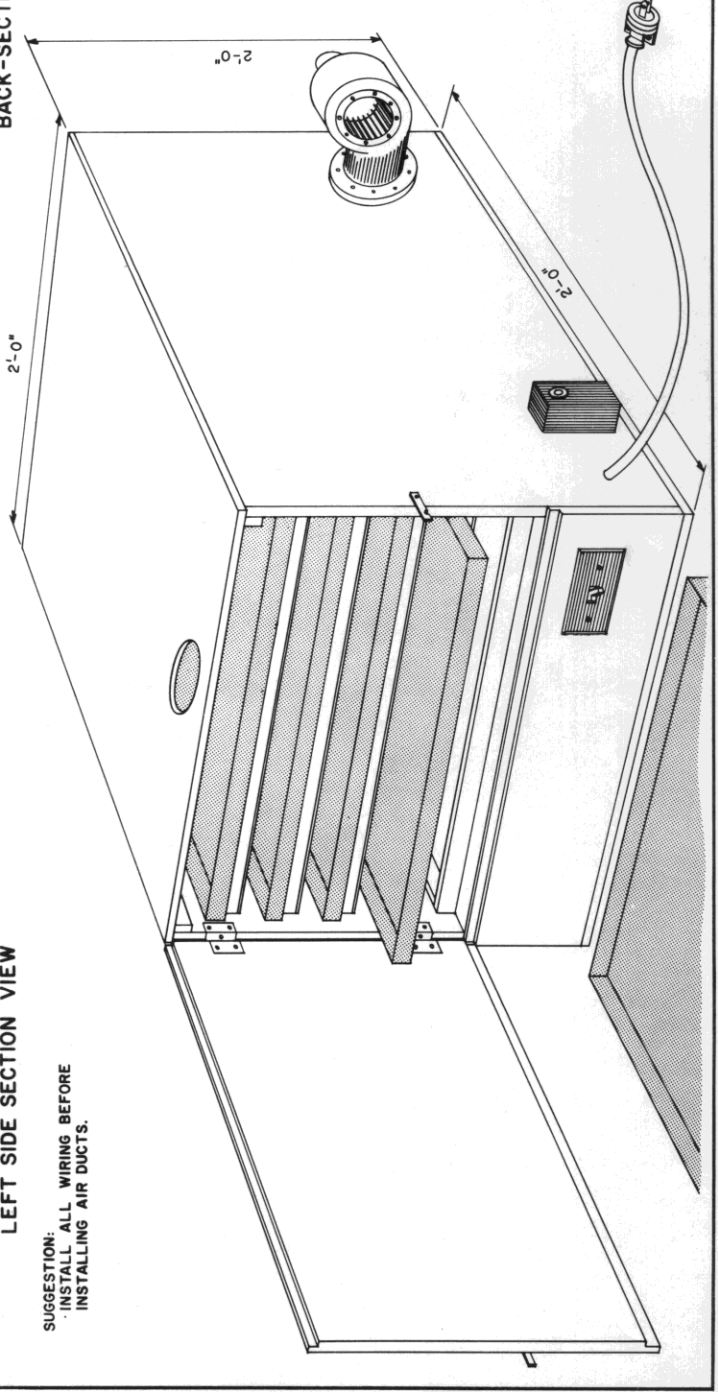

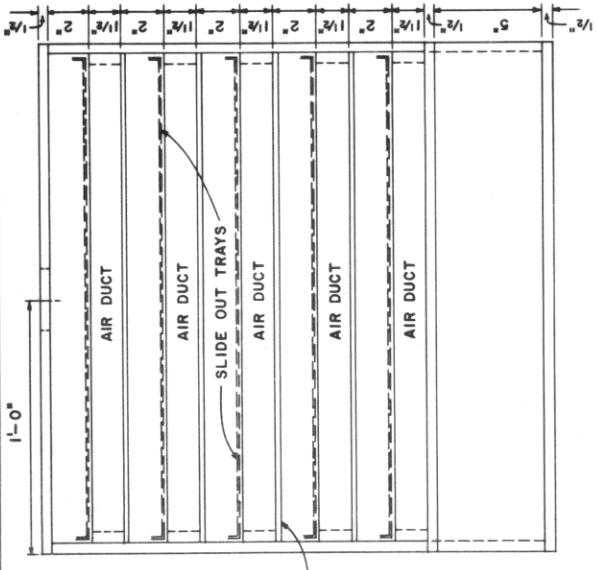

NOTE: ALL JOINTS IN AIR DUCTS AND PLENUM CHAMBER SHOULD BE CAULKED.

1/8" TEMPERED MASONITE (CAULK JOINTS)

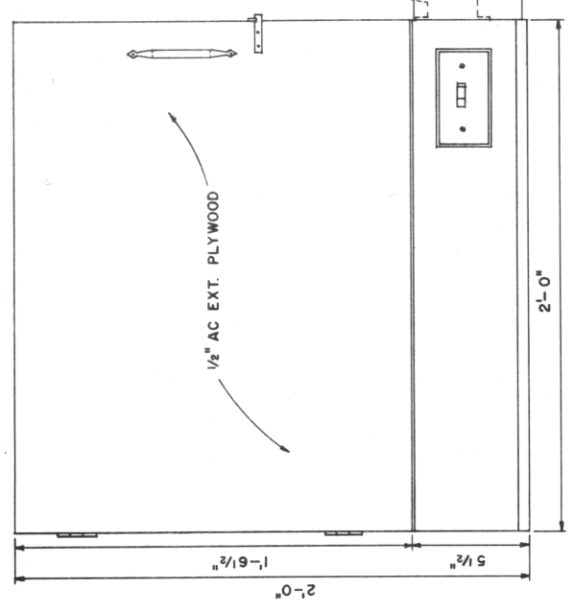
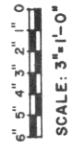

FRONT—"DOOR REMOVED"

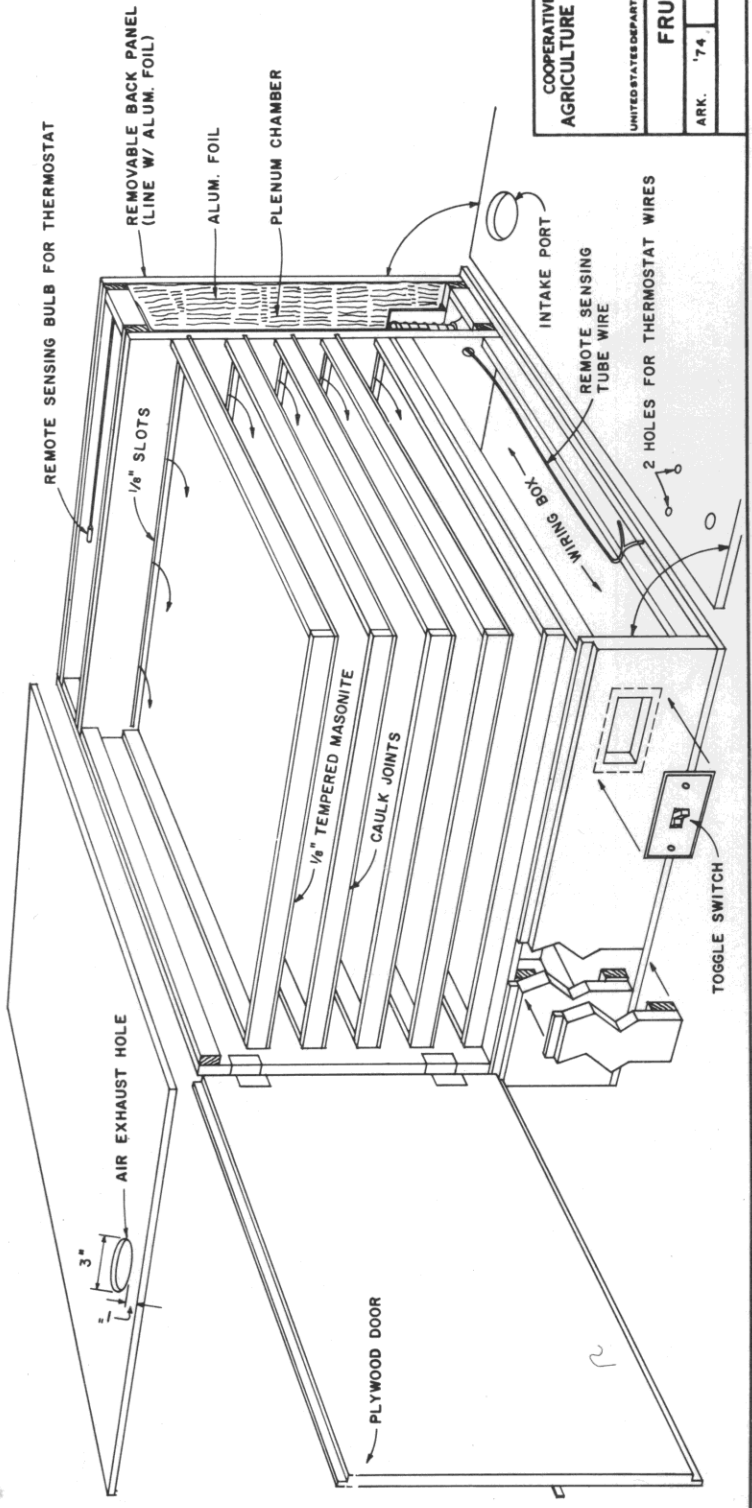

# FRUIT DRYING PROCEDURE

- APPLES:**
- PEEL, CORE, & SLICE IN 1/4" RINGS
  - DIP FRUIT IN BLEACHING SOLUTION\* FOR 2 MINUTES.
  - PLACE PREPARED FRUIT IN LARGE PLASTIC BAG, SEAL, & REFRIG. OVER-NIGHT FOR BEST RESULTS.
  - PLACE FRUIT EVENLY IN TRAYS, & PLACE TRAYS IN DRIER.
  - SET THERMOSTAT AT 165°
  - DRY TO 15-20% MOISTURE W.B.
  - APPX. TIME REQ. TEMP. OUTSIDE AIR
- | (HRS.) | (°F) |
|--------|------|
| 10-11  | 60   |
| 9-10   | 70   |
| 7-8    | 80   |

- PEACHES:**
- PEEL, PIT, & SLICE INTO 1/4 SECTIONS
  - D. AS ABOVE
  - SET THERMOSTAT AT 145°
  - DRY TO 15-20% MOISTURE W.B.
  - APPX. TIME REQ. TEMP. OUTSIDE AIR
- | (HRS.) | (°F) |
|--------|------|
| 12-13  | 60   |
| 11-12  | 70   |
| 11-12  | 80   |
- \*FOR BLEACHING AGENT USE:  
3 LEVEL TEASPOONS OF 60% SODIUM BISULFITE PER QT. OF WATER.

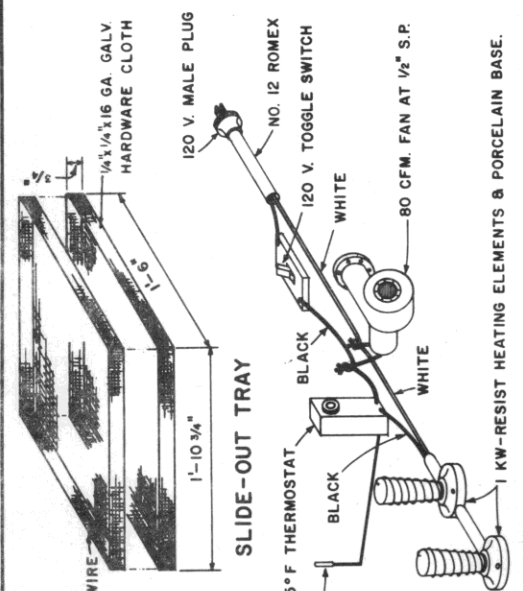

NOTE:  
CIRCUIT: 120 V.-20 A. MIN.

## WIRING DIAGRAM

- ### BILL OF MATERIALS
- 1-4 1/8x1/2" AC EXT. PLYWOOD
  - 1-4 1/4x1/4" TEMPERED MASONITE
  - 1-4 1/2x1/8 GA. -1/4" GALV. HARDWARE CLOTH
  - 6-1 1/2x1/8" NO. 1 FIR
  - 1/2" -44 BOX NAILS
  - 12-NO. 10 WOOD SCREWS
  - 1-SET 1/4" HINGES & DOOR HANDLE
  - 2-1 KW-110 V. CONE TYPE HEATING ELEMENTS
  - 2-110 V. SURFACE MT. PORCEL. LIGHT SOCKETS
  - 1-110 V. 2870 RPM "DAYTON" MOD. #2C781 FAN W/ MOTOR
  - 1-110 V. SINGLE POLE SWITCH & COVER
  - 1-ELECT. SWITCH BOX
  - 1-ELECT. JUNCTION BOX
  - 1-55/175° F THERMOSTAT W/ REMOTE SENSING BULB
  - 2-HEAT SHIELDS 16 GA. 4"x5"
  - 1-4"x5" ALUM. SCREEN WIRE

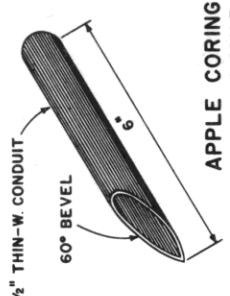

APPLE CORING TOOL  
NO SCALE

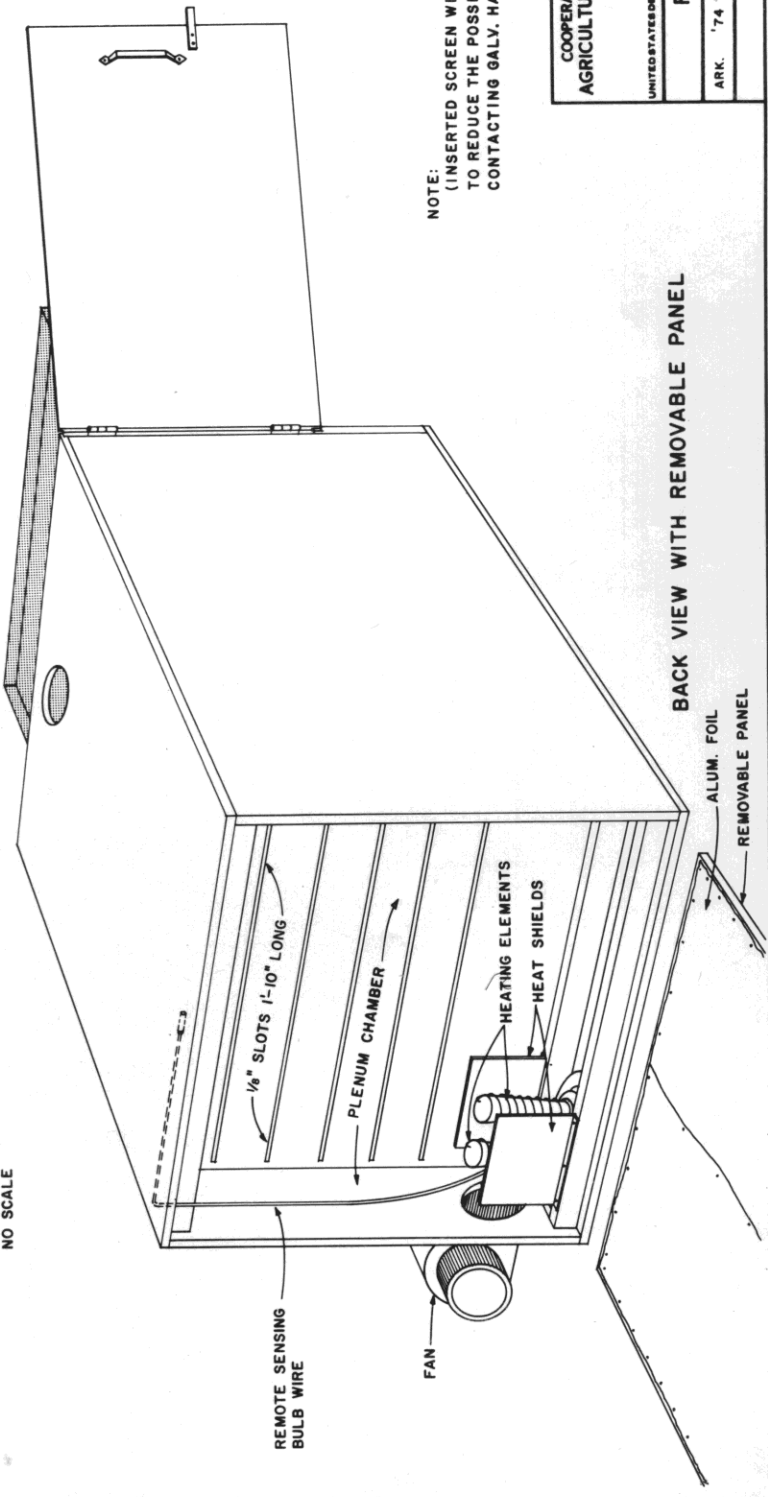

BACK VIEW WITH REMOVABLE PANEL

NOTE:  
(INSERTED SCREEN WIRE LINING IS SUGGESTED TO REDUCE THE POSSIBILITY OF FRUIT CONTACTING GALV. HARDWARE CLOTH.)

- (A) — HONEYWELL MOD. T675A THERMOSTAT, 55 / 175° F
- (B) — 120 V TOGGLE SWITCH
- (C) — IN-LINE FUSE HOLDER W/ 20 A FUSE
- (D) — DAYTON No. 5X850 RELAY
- (E) — DAYTON MOD. 2C781 BLOWER
- (F) — 1 KW - 110 V CONE TYPE HEATING ELEMENT W/ PORCELAIN BASE

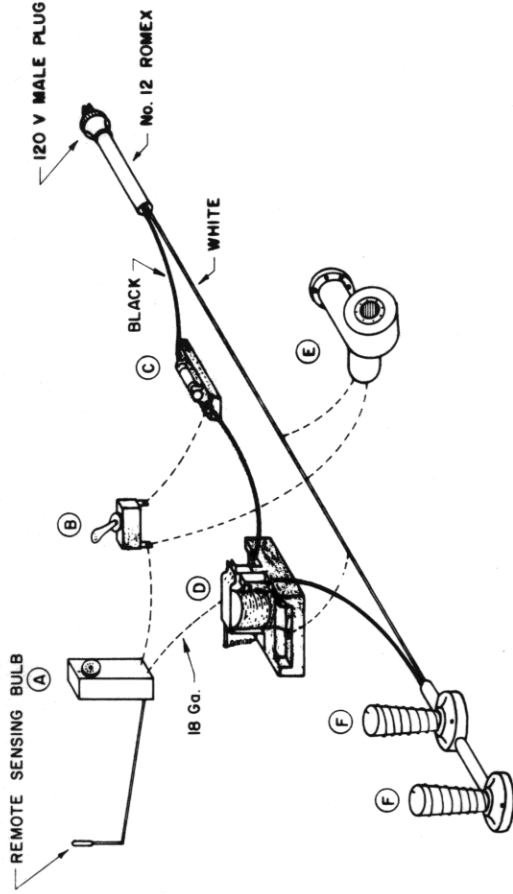

ALTERNATE WIRING DIAGRAM

NOTE:

WIRING DIAGRAM SHOWN ON SHEET 3 REQUIRES A LINE VOLTAGE THERMOSTAT RATED AT 20 AMP. RESISTIVE. IF THIS TYPE OF THERMOSTAT IS NOT AVAILABLE, THE WIRING DIAGRAM SHOWN ON THIS SHEET MAY BE USED. THE OPERATION OF THIS DRYER REQUIRES A 110 V. - 20 AMP. CIRCUIT. TO PREVENT OVERLOADING OF CIRCUIT, DO NOT OPERATE DRYER ON A CIRCUIT WITH OTHER APPLIANCES.

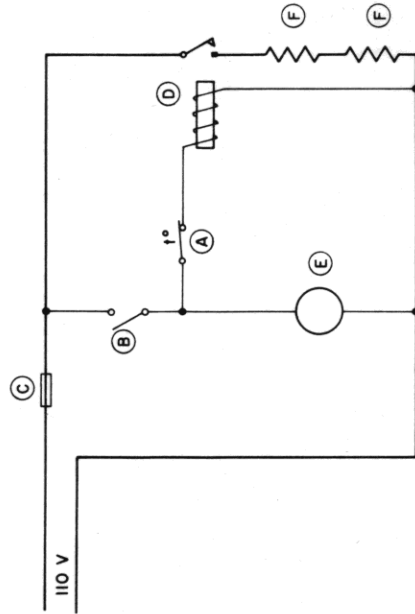

SCHEMATIC

Information Given Herein is For Educational Purposes Only. Reference To Commercial Products Or Trade Names is Made With The Understanding That No Discrimination is Intended And No Endorsement is Implied.