



Corner Display Cabinet

Here's a great way to perk up a lost corner. Build this corner cabinet and fill it with all your favorite things! The shelves are tall enough to accommodate pictures, your tallest knickknacks, and a huge vase of flowers.

Materials

- 3 linear feet of 1 x 6 pine
- 18 linear feet of 2 x 2 pine
- 18 linear feet of 3-inch-wide beaded molding
- 1-1/2 sheets (4' x 8') of 3/4" plywood
- 4 decorative pine squares

Hardware

- 42 1-5/8" wood screws
- 82 1-1/4" (3d) finishing nails
- 12 1-1/" (4d) finishing nails

Special Tools and Techniques

- Bevels
- Miters

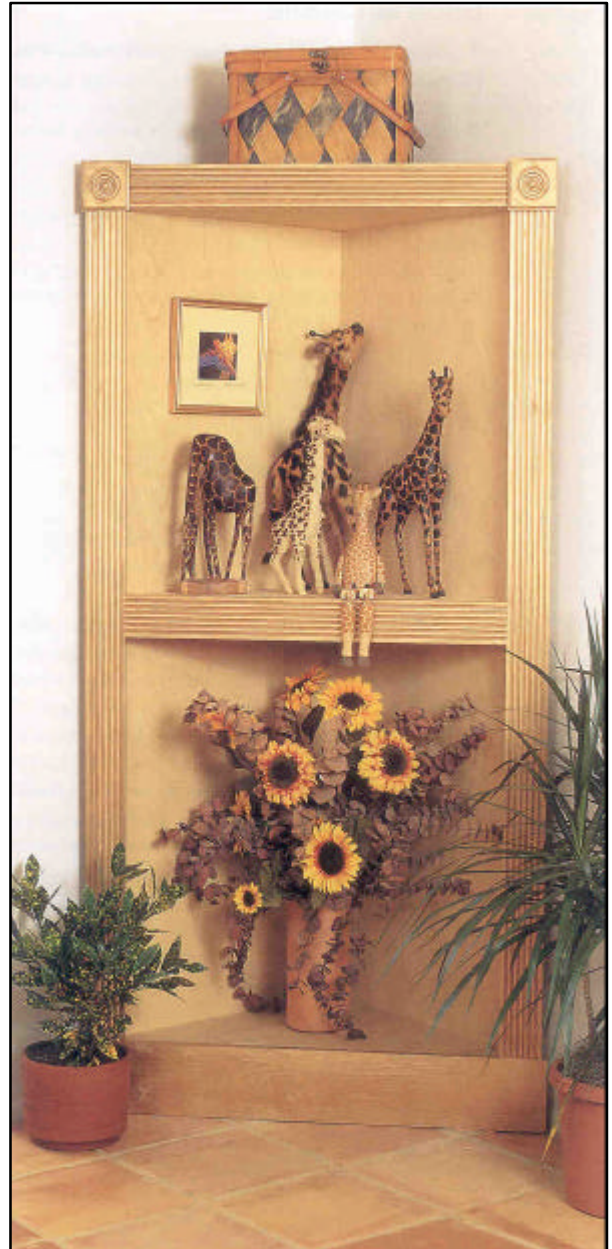

Cutting List

Code	Description	Qty.	Materials	Dimensions
A	Wide Side	1	¾ plywood	23" x 72"
B	Narrow Side	1	¾ plywood	22-1/4" x 72"
C	Top	1	¾ plywood	21-1/2" x 21-1/2" x 30-1/2" triangular
D	Shelf	1	¾ plywood	21-1/2" x 21-1/2" x 30-1/2" triangular
E	Bottom	1	¾ plywood	21-1/2" x 21-1/2" x 30-1/2" triangular
F	Bottom Trim	1	1 x 6 pine	34-1/2" long
G	Support Strips	2	2 x 2 pine	Cut to fit
H	Beveled Strips	4	2 x 2 pine	Cut to fit
I	Decorative Squares	4	Pre-made	4 x 4 inches
J	Beaded Trim	6	3" wide beaded trim	Cut to fit

Making the Cupboard

1. Cut one wide side (A) from ¾-inch plywood, measuring 23 x 72 inches.
2. Bevel one 72-inch edge at a 45-degree angle, as shown in *Figure 1*.
3. Cut one narrow side (B) from ¾-inch plywood, measuring 22-1/4 x 72 inches.
4. Bevel one 72-inch-edge at a 45-degree angle, as shown in *Figure 1*.
5. Place the narrow side (B) flat on a level surface, with the beveled edge facing upward. Place the unbeveled 72-inch edge of the wide side (A) against the 72-inch unbeveled edge of the narrow side, as shown in *Figure 2*. When the pieces are correctly positioned, you should be able to place a straightedge flat against both beveled edges as shown in *Figure 2*. Apply glue to the meeting surfaces and screw through the wide side (A) into the edge of the narrow side (B). Use 1-5/8-inch screws spaced about every 6 inches.
6. Cut three right triangles from ¾-inch plywood, each measuring 21-1/2 inches on the short

sides. Label one piece “top” (C), one “shelf” (D), and one “bottom” (E).

Figure 1

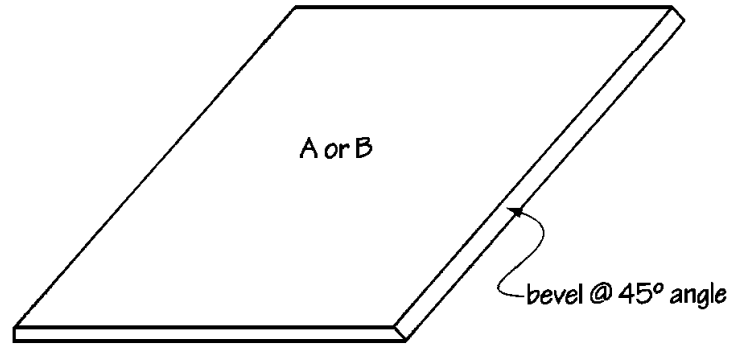

7. Attach the top (C) flush with the top edges of the wide and narrow sides (A and B), as shown in *Figure 3*. Apply glue to the meeting surfaces and screw through the wide and narrow sides (A and B) into the edges of the top (C). Use 1-5/8-inch screws spaced about five inches apart.
8. Repeat the procedure in Step 7 to attach the shelf (D) 34-1/2 inches below the top (C).
9. Again repeat the procedure in Step 7 to attach the bottom (E) 4-3/4-inches from the bottom edges of the wide and narrow sides (A and B).

Figure 2

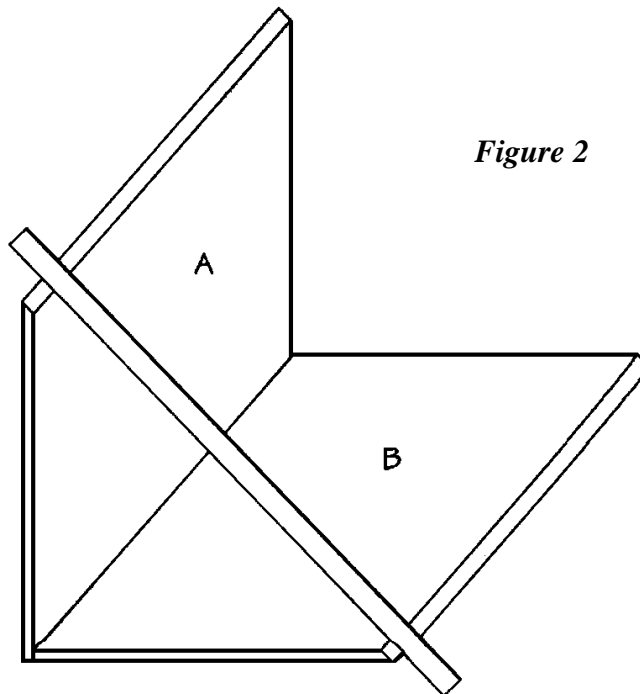
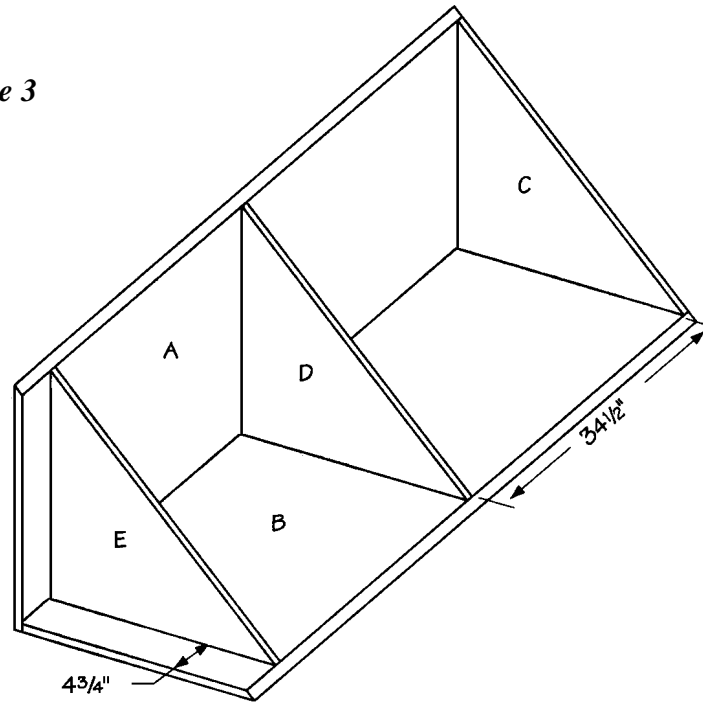

Figure 3



Adding the Trim

1. Carefully measure across the bottom of the cupboard. Add 1-1/2 inches to that measurement and cut one bottom trim (F) from 1 x 6 pine to the new measurement.
2. Miter both ends of the bottom trim (F) at opposing 45-degree angles, as shown in *Figure 4*.
3. Apply glue to the meeting surfaces and fit the bottom trim (F) over the edge of the bottom (E), as shown in *Figure 5*. Screw through the bottom trim (F) into the edge of the bottom (E) and the edges of the wide and narrow sides (A and B) using 1-5/8-inch screws spaced about five inches apart.

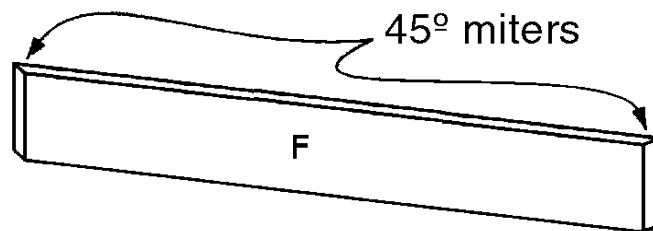

Figure 4

4. To provide support for the front beaded trim, 2 x 2 strips (G) must be attached to both top (C) and the shelf (D). Refer to *Figure 6* to measure and cut 2 x 2 strips for the underside

of the top (C) and shelf (D). Both ends of each of the two strips (G) must be mitered at opposing 45-degree angles. Apply glue to the meeting surfaces and nail the strips (G) in place, using 1-1/4-inch (3d) finishing nails spaced about every four inches.

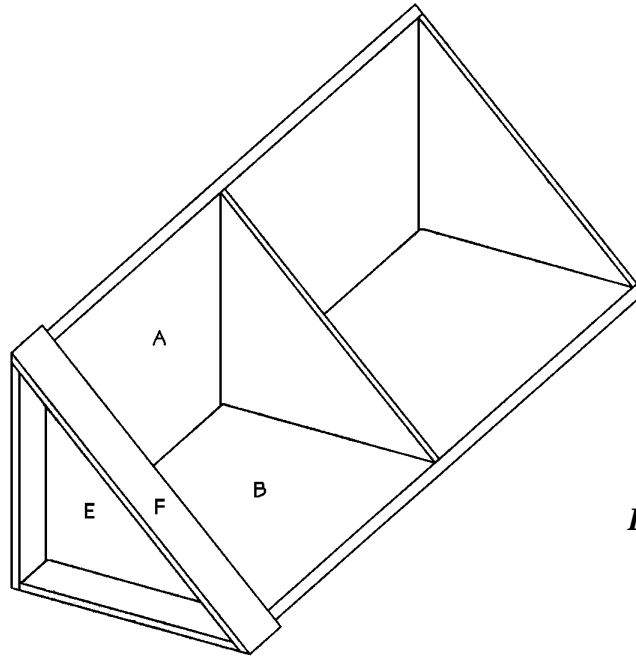

Figure 5

5. The plywood edges on the wide and narrow sides (A and B) must also be supported by 2 x 2 strips (H). Bevel a total of 12 linear feet of 2 x 2 strips (H) at a 45-degree angle, as shown in *Figure 7*.
6. Measure and cut the beveled strips (H) to fit between the top (C), shelf (D), and bottom (E), as shown in *Figure 8*. Apply glue to the meeting surfaces and nail them in place using 1-1/4-inch (3d) finishing nails spaced about every 4 inches.
7. Refer to the project photograph to place the remaining trim on the corner cupboard. Begin by attaching the four decorative squares (I) at the two sides of the top (C) and the shelf (D). The position of the decorative squares (I) is a little bit tricky. The beaded molding (which you will add in the next step) is only 3 inches wide, whereas the decorative squares (I) are four inches wide. So the decorative squares (I) must be positioned so that the beaded molding is centered on all sides of the decorative squares (I), as illustrated in *Figure 9*. Measure carefully and glue and nail the four decorative squares (I) in their positions. Use two or three 1-1/2-inch (4d) finishing nails through each of the decorative squares (I).
8. Again refer to the photograph for placement of the beaded trim (J). Measure and cut each of the six pieces to cover both sides, the top, and the shelf front. Apply glue to the meeting surfaces and nail through the beaded trim (J), using four or five 1-1/4-inch (3d) finishing nails on each piece.

Finishing

1. Fill the screw holes, crevices, and cracks with wood filler.
2. Sand all surfaces of the completed cupboard.
3. Stain or paint the cupboard the color of your choice. We painted the front trim pieces with a

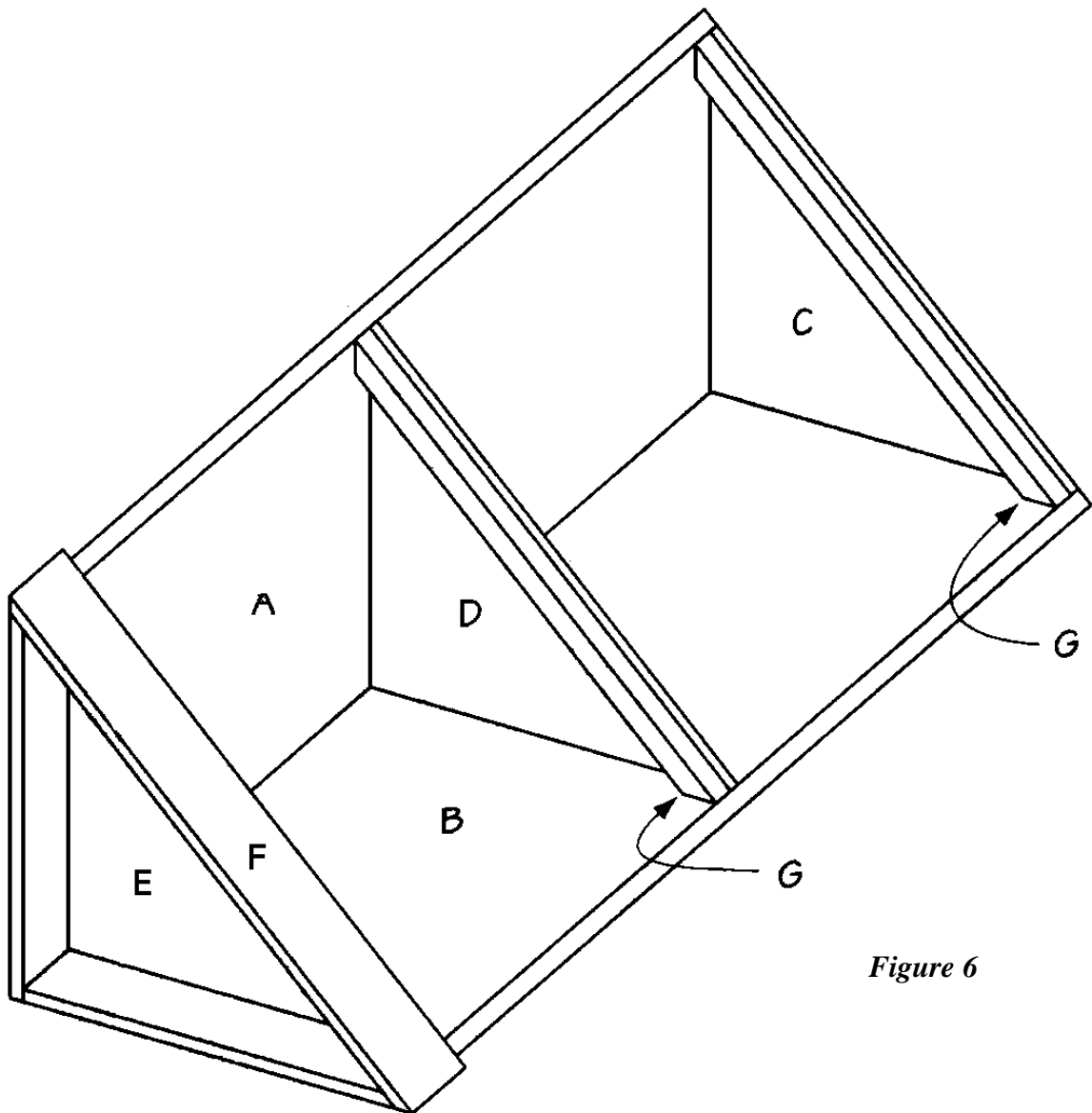
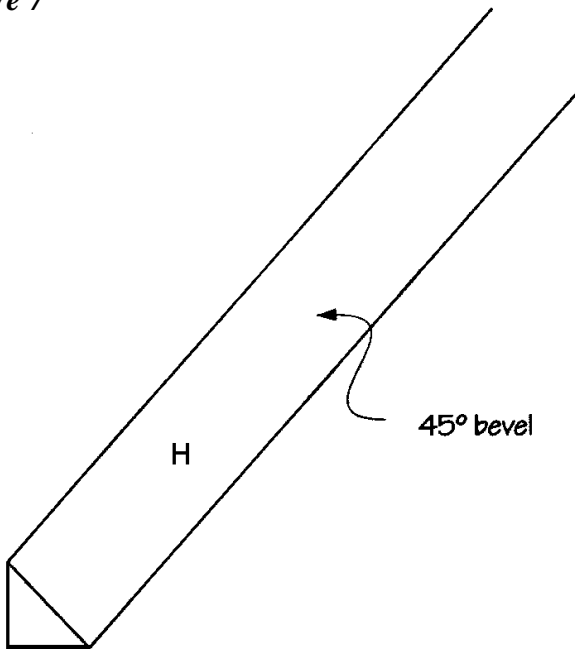

Figure 6

metallic bronze paint and left the remainder of the cupboard its natural color. Then we sealed

the entire cabinet with a glossy polyurethane.

Figure 7



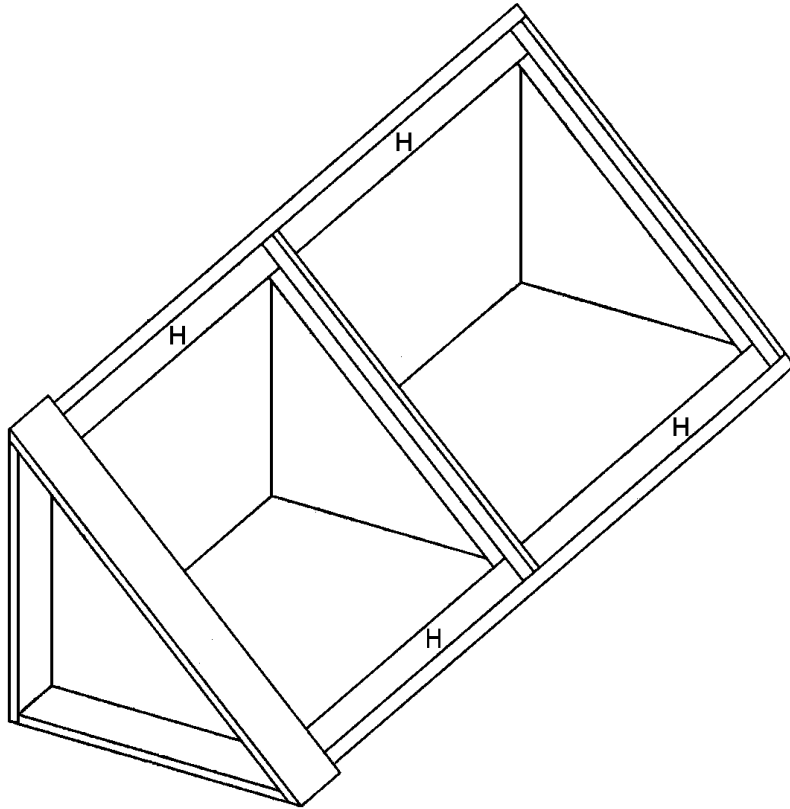
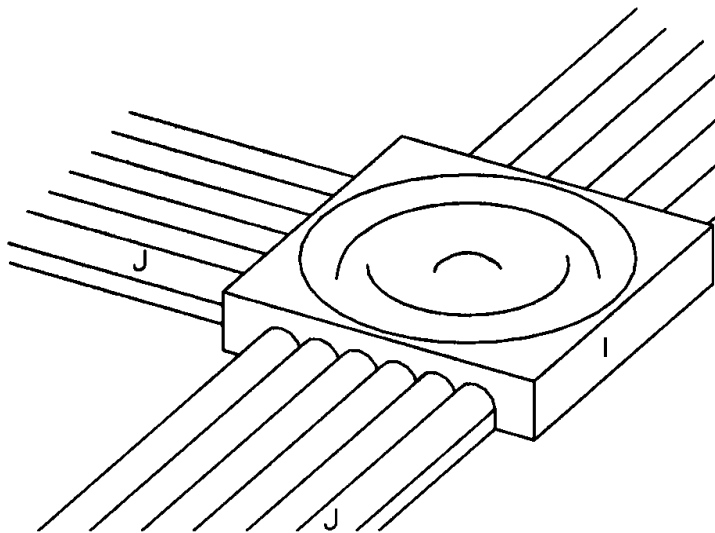

Figure 8



Close up of Trim

Coordinate Your Room With Other Projects Available From [wowimadeit.com](http://www.wowimadeit.com)



This photograph contains seven projects available from www.wowimadeit.com: Dining Table, Entertainment Center, Tiled Coffee Table, Corner Display Cabinet, End Table, Mirror, and Buffet. Notice how everything is coordinated, and the rooms look unified because all of these pieces are designed in a similar scale, made of similar materials, and finished with similar techniques and colors.