

Articles & Plans

Free Project Plans

Select Articles

Searchable Links

Magazine Extras

Books

Bookstore

Woodworker's Book Club

Store & Services

Subscribe

Buy Back Issues

Gift Subscription

Plans For Sale

Article Index

Customer Service FAQs

Subscriber Services

Other

E-mail Newsletter

Free Information

Advertising Info

Contact the Staff

Home

Download FREE woodworking plans for these projects

The following projects were featured in *Popular Woodworking* in the last couple years. In each free plan you get a cutting list, a description of the construction process and a downloadable construction drawing in PDF format.



Pattern Cutting on the Table Saw

With a simple jig, as seen in these free woodworking plans, you can transform your table saw into an accurate pattern-cutting machine.

[CLICK HERE](#)



A Contemporary Mobile File Cabinet

Looking for a sleek and contemporary project that helps organize? Just read this free plan to see how easy it can be. [CLICK HERE](#)



Heirloom Photo Album

A special board and some hardware are all you need to make this album. [CLICK HERE](#)



Rough Lumber Cut-off Stand

Cut long lengths of lumber to rough size without four sawhorses or a helper. [CLICK HERE](#)



Arts & Crafts Globe Stand

If this globe-stand design doesn't suit you, we offer three other drawings to give you some options. [CLICK HERE](#)



Shaker Storage Cabinet

With two different shelving systems, this face-frame cabinet stores light or heavy stuff. Just look at these drawings, techniques and plans to see for yourself. [CLICK HERE](#)



European Telephone Console

Keep your phone, phone books, keys and small umbrellas in order with this fashionable modern console. [CLICK HERE](#)



Router Table-Mate

Make your own router table for less than \$50 by using these woodworking drawings and techniques. This one is easy to make and store. [CLICK HERE](#)



What You Must Know About Shelving

Learning to build shelving is a basic skill every woodworker must master. Here are the basic rules everyone must follow. [CLICK HERE](#)



Garden Swing

This swing is simple to build but looks great in your yard or on your porch [CLICK HERE](#)



Morris Chair

I don't care what they say about dogs, Morris chairs are a man's best friend. This reproduction of a Shop of the Crafters chair is sturdy and comfortable, as you can learn from these free woodworking plans.. [CLICK HERE](#)



Tansu Chest

This Japanese-style Tansu chest can be used in several different configurations to fit your lifestyle. No matter how you stack it, it stores a lot of items, as we show you with this free project.. [CLICK HERE](#)



Contemporary Shelves

It's rare that bookshelves look as interesting as the objects you display on them. These shelves are easy to build and knock down for storage. [CLICK HERE](#)



Drill Press Table

Drill presses are designed mostly for metalworking. Dress yours up with this table - we give you all the project plans - and you'll find it indispensable for woodworking, too. [CLICK HERE](#)



Bungalow Mailbox

This project was by request. As I live in the 'burbs and have to walk to the curb to pick up my bills, a mailbox mounted next to my front door would be purely decorative. [CLICK HERE](#)

© Popular Woodworking • [F+W Publications Inc.](#)
[Customer Service FAQs](#)

Popular Woodworking



Articles & Plans

Free Project Plans

Select Articles

Searchable Links

Magazine Extras

Books

Bookstore

Woodworker's Book Club

Store & Services

Subscribe

Buy Back Issues

Gift Subscription

Plans For Sale

Article Index

Customer Service FAQs

Subscriber Services

Other

E-mail Newsletter

Free Information

Advertising Info

Contact the Staff

Home



Download a construction drawing



Pattern Cutting on the Table Saw

With a simple jig, you can use your saw to cut duplicates of parts.

Sure, I have a router and a handful of pattern-cutting bits. But many times when I need to make duplicates of an odd-shaped part, I turn to my table saw instead.

With a shamefully simple jig (it's two pieces of wood) clamped to my saw's fence, I can cut patterns all day long. I think it's faster than pattern cutting with my router for several reasons.

First, when roughing out the shape of the blank on my band saw, I don't need to cut real close to my line like I do when pattern routing. I only have to get within 1-1/2" of the line instead of within 1/16" to 1/8".

Second, there's less clamping involved with this table-saw method. Normally I screw or nail my template to the side of the part that won't show (the underside of a shelf, for example) and go. I can do this with pattern routing, too, but I'll still need to clamp everything to my bench, make part of the cut, readjust the clamps and then finish the cut. When I use the table saw, I screw it and cut it.

Build the Jig

The jig should take five minutes to build. It is simply two narrow strips of 3/4"-thick wood nailed and glued on one long edge into an "L" shape. One of the strips of wood should be as long as your table saw's fence. Its width depends on how thick your project's stock is. For cutting patterns in 3/4" stock, rip this board to 1-5/8" wide. The second one should be 1-3/4" wide and about 6" shorter



This complex shelf was traced, roughed out and trimmed to size in less than five minutes with only one clamping setup. Try that with your router.



Once your jig is clamped to your fence, you need to align its edge with your sawblade. A square will get you close, but a follow-up test cut or two will get you exactly where you want to be.



One of the big advantages to cutting patterns with your table saw is you don't have to be real accurate when roughing out the stock. With a router, you need to cut pretty close to the line so the tool can handle trimming the last bit of stock flush. With this table saw setup, you have to be within 1-1/2" of your line — which means you're much less likely to accidentally cross it, too.



For this cherry corner cabinet, I screwed the pattern to the shelf on its sappy underside. A

than the first board. Nail and glue these two boards together using the drawing as a guide.

couple brad nails would also do the trick. Align the shortest part of the pattern flush with a jointed or straight-sawn edge.

Set Up Your Jig and Use It

Install a quality combination blade in your saw. Clamp the jig to your fence with the jig flush to the table. Slide the table saw's fence over so the jig overhangs the blade and raise the blade until it almost touches the jig.

Using a square, line up the edge of the jig with the edge of your sawblade's teeth. Now wax the edge of the jig to make things slide more easily.

Screw a couple pieces of scrap together and test your setup. When the cut is complete, the two pieces should be perfectly flush. Adjust the fence until this is the case.

Now you're set. Align the shortest part of the pattern with a jointed or straight-sawn edge. Trace the pattern on your stock using your template as a guide. Rough out its shape using your band saw and then screw the template to your stock. Push the pattern against your jig's face and slide it forward. Be cautious when sawing short lengths. You'll probably be surprised how accurate and easy this is, and give your router a rest every once in a while. **PW**

Christopher Schwarz is a senior editor at *Popular Woodworking*

[Return to Free Projects Plans](#)

Popular Woodworking



Articles & Plans

Free Project Plans

Select Articles

Searchable Links

Magazine Extras

Books

Bookstore

Woodworker's Book Club

Store & Services

Subscribe

Buy Back Issues

Gift Subscription

Plans For Sale

Article Index

Customer Service FAQs

Subscriber Services

Other

E-mail Newsletter

Free Information

Advertising Info

Contact the Staff

Home



Download a construction drawing



A Contemporary Mobile File Cabinet

An elegant design that provides no-nonsense functionality.

A few years ago I built some office furniture for a local internet consulting company, and recently they called me back: Not only had they survived the dot-com crash, but they needed some mobile file cabinets. I had already developed a unique look for their computer workstations: birch surfaces surrounded by rounded-over solid cherry edge-banding. The style was crisp, clean and a nice fit for the company's bright and airy office.

My clients had a few ideas in mind: They planned to move the cabinets around so that people could share files, and they wanted to wheel the cabinets underneath their desks to be easily accessible without occupying extra floor space. Locking casters and the ability to hold letter-size hanging file folders would also be nice. These guidelines created a set of dimensions to work from, and the fact that these cabinets are mobile also dictated that they be finished on all sides so that they could be enjoyed from all angles.

In terms of materials, we ruled out solid-wood panels because of their inevitable cross-grain expansion and contraction, and laying up the veneers myself would've been prohibitively expensive.



During the second stage of cabinet assembly, laying the cabinet on its side keeps you from fighting with gravity. The cabinet comes together relatively easily, and the alignment is a snap thanks to the biscuits.



Go slowly while rounding over the edges, as the cherry can tear out and splinter if a cut is rushed. The roundover is key to the smooth,

Fortunately I was able to locate some nicely figured $\frac{3}{4}$ "-thick birch plywood, and this allowed us to keep the look we were after without spending a fortune or sacrificing durable construction.

Cutting and Edge-banding the Cabinet Parts

First inspect the edges of the plywood, because the joint between the solid-wood edge-banding and the plywood panel needs to be crisp. Although it is tempting, you can't assume that a factory edge is up to snuff, and a quick glance may reveal numerous dings, dents and scratches. I often end up ripping $\frac{1}{2}$ " off of each factory edge. To minimize tear-out on cross-cuts, I use a sharp plywood blade and a zero-clearance throat plate. Feeding the panels more slowly, good-side facing up, also helps keep the cuts free of tear-out.

Once your panels are neatly trimmed to size, it's time to mill some edge-banding. I use cherry because I like the color that it darkens to, but substitute as you like: I've also used walnut with pleasing results. I simply plane the cherry to $\frac{3}{4}$ ", then rip it into $\frac{1}{4}$ " strips. Precision is critical, as inaccurately sized strips will either overhang the plywood panels and need to be trimmed, or they won't cover the edge entirely and you'll have to make new ones. I usually mill some extra stock in case I notice a defect in one of the strips that wasn't evident beforehand. The cut list calls for 12 strips, which allows for one extra.

I own a few clamps that are designed for attaching solid-wood edge-banding, but they end up gathering dust for several reasons.

clean feel of the piece.



Using spacers to position the drawer slides eliminates one of the leading causes of poor-fitting drawers: inconsistent spacing of slides. Before putting in the spacers, be sure to brush out any sawdust or woodchips that may have accumulated inside the cabinet. A $\frac{1}{16}$ " discrepancy at this point could cause an annoying misalignment that you'll have to backtrack to correct later on.



A consistent reveal is key to the crisp feel of the piece. The shims shouldn't bow the cabinet sides out at all, but should fit snugly to ensure that the drawer front is centered and that the reveal is even on both sides.

To edge-band a number of panels requires more clamps than I'm willing to buy, and some clamps seem to lack the clamping pressure that I'd like. I also hate lugging heavy, clamp-laden panels around the shop while I wait for glue to dry. My solution is probably not original, but it is highly practical: I use blue painter's-grade masking tape. It is quick, inexpensive and lightweight. You can even stack a series of panels on top of each other to use space efficiently. And because an ounce of prevention is worth a pound of cure, I use just enough glue to create a tiny amount of squeeze out, which I then wipe up.

Because the edge-banding may overhang a bit, I use a router with a flush-trim bit to carefully remove the offending cherry; a careful touch with a random-orbit sander will remove any glue residue left over. The side panels need to be edge-banded on all four edges, and the top and bottom panels get edge-banded on their front and back edges only. The back receives no edge-banding at all. As a word of caution, veneered plywood is notoriously unforgiving when it comes to sanding. I've learned the hard way that there is no adequate method for repairing sand-throughs in the top layer of veneer, so work carefully to ensure that you'll have to do a minimal amount of sanding.

Assembling the Cabinet

I use biscuits here because they are strong and reliable. In addition, they are invisible once the cabinet goes together, and I didn't want any filled nail holes or plugged screws interfering with the lines of the piece or interrupting the flow of the grain.

I assemble the cabinet in two steps:
First I sandwich the back between

the top and bottom, and once the glue there has set, I sandwich that assembly between the sides. For the first step, I clamp the three parts together and line them up precisely. After marking the locations for biscuits, I pull off the clamps and cut the slots. After dry-fitting, I glue it up and wait a few hours. For the second step, I place one side panel flat on the table, inside facing up. I position the top-back-bottom assembly correctly on top of that, and finally place the remaining side on top of it all. With a couple of clamps holding the parts snugly in place, I mark the biscuit locations, then repeat the process I used on the first half of the cabinet assembly.

With a roundover bit in a router, I ease each edge, which softens the sharp lines of the cabinet. By routing the edge-banding after the cabinet is assembled, the inside corners of the edge-banding flow together smoothly, and the eye is swept through graceful little curves that add a fine detail to the finished piece.

Making the Drawers

I build the drawers out of Baltic birch plywood because it is attractive, stable and inexpensive. If you like, you can mill solid-wood panels for the drawer parts – if you do, dress the stock to 7/16", as the Baltic birch plywood sold as 1/2" actually measures out at 1/16" less. Refer to the cut list for the quantities and dimensions you'll need here. Once you've got the drawer parts cut, rip a groove in the bottom of each – you could use a dado blade here, but for a small number of parts like this, I don't take the time to change blades: I just make two passes side-by-side for the 1/4" groove.

For this project, I use a rabbet-dado

joint to lock the drawer parts together. It is a strong mechanical joint with plenty of surface area for glue. I sketch it full-sized on paper, then set up my table saw to cut the dado on the inside face of the sides.

I use my miter gauge with a stop attached to make sure the dados are cut at a consistent distance from the ends of the drawer sides. This will take two passes. I then cut the rabbet in the drawer fronts and backs with a similar setup – just change the blade height and move the stop on your miter gauge to correctly position the cut. Test the fit of the joint now while you're still set up to make changes.

Once the rabbets and dados fit snugly, cut out the drawer bottoms. During glue-up, check that the drawers are square by measuring their diagonals. This ensures that the drawer fronts will line up evenly. If a drawer is slightly out of square, clamp it across the longer diagonal and apply pressure until it conforms. Once the glue dries, it should remain in the correct position.

So that hanging file folders can be easily slid forward and backward in the bottom drawer, you'll need to make two rails that mount on the top edges of the drawer sides. I mill two 20" strips of cherry to $\frac{1}{2}$ " x $\frac{5}{16}$ ". I then make two cuts with the table saw to create the "L"-shaped piece needed. The piece can then be screwed into the tops of the drawer sides – be sure to countersink the heads so that they don't stick up and interfere with the movement of files across the rails.

Installing the Drawers

I use 20" Accuride slides because they're smooth and reliable. Each

drawer requires one pair of slides, and each slide can be separated into two pieces: The larger one mounts inside the cabinet, and the smaller one attaches to the drawer. I keep the slides together during installation, and I use plywood spacers to lay them out evenly. With the cabinet on its side, I insert the lower spacer (4-5/8" wide), the first drawer slide, the middle spacer (6-1/4" wide), the second drawer slide, the upper spacer (2-7/8" wide), and finally the upper drawer slide. Then I simply screw the slides in place with three screws. After flipping the cabinet onto its other side, I repeat the process.

With the cabinet upright on my bench, I push the bottom drawer halfway in and place 1/8" shims underneath it to establish a consistent and correct height for the drawer. I pull out the slides (it should be a snug fit, but not excruciatingly tight) and line them up with the front edges of the drawer. I screw in the front edges of the slides, and then pull the drawer out all the way. With the shims still under the back edge of the drawer, I screw in the back-ends of the drawer slide. The top two drawers go in the same way, except I use thicker shims on top of the bottom drawer because it receives a taller drawer front to hide the tabs on file folders that protrude above the drawer box.

Trim your false drawer fronts to size on the table saw and iron on veneer tape to all four edges. To attach the drawer fronts, I remove the top two drawers and push the bottom drawer all the way into the cabinet. I then set the drawer front into position, using 1/8" shims on the bottom and sides to ensure a correct reveal all the way around. I use spring clamps to hold the drawer

front in place, then I run screws into it from the inside of the drawer. The middle drawer front attaches the same way, but the top one doesn't have room to get a clamp around it. I solve this dilemma by dabbing some quick-set epoxy on the back of the drawer front then pressing it into position. Flipping the cabinet onto its back and shimming around the edges of the drawer front assures that it will remain aligned. Once the epoxy has cured, the drawer front can be secured with screws like the others.

To attach the drawer pulls, I make a template from a scrap of 1/4"-thick plywood and cut it to the same size as the upper drawer fronts. I draw lines across the vertical and horizontal centers of the template, and center my pull relative to these crosshairs. Once the holes are drilled on your template, you can place it directly on the drawer fronts and drill through your pre-positioned holes. Using a template like this might seem like extra work but, it saves time and guarantees consistent placement on each drawer front.

Finishing it Up

For an office environment, I favor the durability of oil-based polyurethanes, although if I were building this for my home, I might be tempted by the hand-rubbed feel of the newer gel varnishes. When your finishing process is completed, simply screw on four 2"-diameter wheels (locking casters will keep it from rolling around while you open and shut drawers), and bolt on the drawer pulls.

And now, the moment you've been waiting for: Go ahead and fill those drawers with all the stuff that usually clutters up your desk.

While I can't promise that you'll be more efficient or productive as you tend to whatever paperwork keeps you away from the workshop, I'm confident that you'll enjoy the smooth, crisp look of your new rolling file cabinet. And the clean desktop isn't half bad, either. **PW**

Chris Gleason designs and builds contemporary furniture.

[Return to Free Projects Plans](#)

© **Popular Woodworking** • [F+W Publications Inc.](#)
[Customer Service FAQs](#)

Popular Woodworking



Articles & Plans

Free Project Plans

Select Articles

Searchable Links

Magazine Extras

Books

Bookstore

Woodworker's Book Club

Store & Services

Subscribe

Buy Back Issues

Gift Subscription

Plans For Sale

Article Index

Customer Service FAQs

Subscriber Services

Other

E-mail Newsletter

Free Information

Advertising Info

Contact the Staff

Home



Download a construction drawing



Heirloom Photo Album

Your photos will be more memorable when bound in this custom-made album.

Given the current craze for scrapbooking, I thought it high time we woodworkers weigh in with our own version of what a memorable photo album should look like.

And if you are tempted to rip out these magazine pages before your spouse sees them and places an order for say, a dozen or so, fear not. This truly is an easy project. It could even be simpler than what you see here if you skip the resawing and bookmatching of the ¼"-thick front and back covers.

In fact, if you were making five or six at a time, you could probably spend no more than a half hour on each one. Or, you could go in the other direction and make it more complicated with inlay or chip carving on the front.

There could, in fact, be many variations on this project. You could easily alter the size of the covers for smaller photo album sheets, you could set it up with blank pages for use as a personal journal, or documents from your family tree research.

No matter what direction your version of this project takes, two simple elements will make it all possible: the post binding screws that fix the covers and pages together, and the small-scale continuous hinge that allows the covers to open, making them truly functional. The hinges and post binding screws can be ordered through the Lee Valley woodworking catalog.



Brass miniature continuous hinges are a cinch to cut with a pair of metal shears. Make your cut at the joint where two hinge leaves meet nearest your ideal length.



An ordinary paper hole punch enlarged the holes that were pre-punched by the manufacturer of the photo album sheets.

Getting Started

A trip to an art or office-supply store is the first step. Select the photo page size you want to work with. Some pages simply are plain sheets that are inserted in clear plastic sheet protectors. The protectors, in turn, are usually punched for use in a three-ring binder. The sheets I used were hole punched for post binding and "hinged," meaning each sheet was made to fold at a given place along the edge where it would be bound into the album.

I selected a sheet size that was 12" x 12". Next I ordered my post binding screws and hinge from Lee Valley. The screws, called "Chicago Bolts" in the catalog, come in various lengths, with each length allowing for a 1/4" adjustment. The brass hinge comes in a 3' length and is easily cut.

The page size and hinge gave me dimensions I could start to work with. The wood covers' finished size is 1/4" x 12-1/2" square. This allows 1/4" for the cover to overlap top and bottom. The bound side has 1/8" overlap, leaving 3/8" for the open side. When I cut the pieces I made the width 12-5/8". This allowed a table saw cut to separate the binding strip from the cover piece. The cover thickness was 1/4", which is perfect for the hinge leaf.

A Word About Wood Choice

My album covers are made using feather-figured walnut that was resawn and bookmatched. It came from a tree in my neighborhood that was taken down and sawn into lumber about three years ago. Although it's been air drying all this time I was nervous as a cat about my pieces warping after resawing

and glue up. Highly figured wood often has a mind of its own. I know that walnut is a relatively stable wood, like mahogany, but I kept my pieces on a flat surface with a weight on top until I was able to put a finish on them. Even at the thin $\frac{1}{4}$ " dimension, I was lucky and both pieces have remained perfectly flat.

The point of all this is to remind you to be cautious about your wood selection and handling. Try to use a stable species. A narrower album would be less risky.

Hardware Installation and Finishing

I followed the hole patterns for the post binding screws that were already in the album sheets. Allowing for the top and bottom overhang, my hole center for the screws was $2\text{-}\frac{9}{16}$ " from the top and bottom. From the binding edge, I marked a hole center of $\frac{1}{2}$ ".

The posts required a $\frac{1}{4}$ " hole with a $\frac{1}{2}$ "-diameter counterbore to recess the flat heads of the screws. I used a Forstner bit for drilling in my drill press. It is necessary to drill the front and back banding strip exactly alike.

At this point I progressively sanded to 220 grit, rounded the outside corners to a $\frac{3}{16}$ " radius, and heavily eased the edges, except for the edges where the hinge would be installed.

The finish may be a bit more complicated than you are accustomed to, but the fantastic figure in the walnut demanded as good a finish as I know how. And it was worth each step. Because walnut is an open-pore wood, I filled the grain using paste wood filler. I

added oil-based walnut stain to the filler to color the filler and the wood. After applying the filler, I allowed it to dry for 24 hours.

For a clear top coat I used a lacquer that comes in an aerosol spray can. The product is the best lacquer in a can I've ever used. It's called Master's Magic and is available from The Woodturners Catalog. A can of sanding sealer and satin finish lacquer are required, and the product should be used only in a well-ventilated area free of open flames (including pilot lights on water heaters or furnaces) or potential sparks.

After applying the sanding sealer, carefully sand with 360-grit paper, being especially careful near the edges. The idea is to lightly sand down any dust particles or bubbles that may have formed but not to sand into the stain color below the sealer. After sanding the sealer, spray two top coats with the satin finish. Allow the finish to cure overnight, even though it will be dry to the touch in 15 minutes.

I used a pair of snips to cut the hinges to 12-1/8" long. Cut the hinge at one of the leaf joints. The hinges are attached using flat-head brads that you should order along with the hinges. Pre-drill the holes for the brads into the edge of the wood leaving about 1/4" of the brad length not drilled. Pre-drilling should ensure nothing pokes through the face of the cover.

Insert the post part of the post binding screws and fill your photo page inserts. I found that it was necessary to slightly enlarge the holes in the sheets with an ordinary paper punch. When done, lay the

other cover over the post and then insert the screw.

If you are considering leaving the album on a coffee tabletop, or if you just want to protect the back cover from scratches, put a felt bumper pad in each corner of the back cover.

As a photo album or scrap book, this project makes an extra special gift for an extra special occasion. Is there a family wedding in your future? **PW**

Steve Shanesy is editor and publisher at *Popular Woodworking*

[Return to Free Projects Plans](#)

© **Popular Woodworking** • [F+W Publications Inc.](#)
[Customer Service FAQs](#)

Popular Woodworking



Articles & Plans

[Free Project Plans](#)

[Select Articles](#)

[Searchable Links](#)

[Magazine Extras](#)

Books

[Bookstore](#)

[Woodworker's Book Club](#)

Store & Services

[Subscribe](#)

[Buy Back Issues](#)

[Gift Subscription](#)

[Plans For Sale](#)

[Article Index](#)

[Customer Service FAQs](#)

[Subscriber Services](#)

Other

[E-mail Newsletter](#)

[Free Information](#)

[Advertising Info](#)

[Contact the Staff](#)

[Home](#)



Download a construction drawing



Rough Lumber Cut-off Stand

Here's a fixture that makes cutting rough lumber to length a snap.

Most garage woodworkers put their rough lumber across a couple sawhorses and crosscut it to length using a circular saw or jigsaw. After the cut, something usually falls to the floor – missing your foot if you're lucky. After some thought, we designed and built this cut-off stand to improve the life of the garage woodworker.

Adjustable in height to accommodate almost any cutting location, this stand works with two sawhorses (or your bench or table saw) to keep your lumber fully supported during a cut.

But that's not all this stand does (our philosophy is if it's going to take up space in a garage shop, it better have more than one use). So we added a removable roller stand to the top that turns the fixture into an adjustable outfeed stand for most of your woodworking machines.

The stand is remarkably simple to build. Make the lower support using $\frac{3}{4}$ "-thick hardwood of your choice that's glued and screwed together using butt joints. The slotted post supporting the top section is formed by cutting, then regluing the pieces – no complicated router work. The top is $\frac{1}{2}$ "-thick Baltic birch plywood pieces nailed together to form a torsion box for extra strength.

From the Bottom Up

To make the stand easily adjustable in height, I chose a post-in-sleeve design. Start with the post. The finished size of the post is given in the materials list, but start with a length of wood that is $\frac{1}{4}$ " wider,



1 To form the post, the rough piece is ripped into three pieces, the center piece is cut to form two small blocks, and then the whole thing is glued back together.



2 As you glue up the column, use the post to check the spacing. The post should slip easily into the sleeved column. You want the post to move easily, but don't make it too loose or you'll make the stand wobbly.



3 The feet are attached to the column with flat-head screws. Watch the screw alignment or you'll drill into another screw.

thicker and longer than the finished size. This leaves room for saw cuts to form the slotted post and fitting room for overall size.

Next, take a look at the square $\frac{1}{4}$ "-20 nut you have for the locking hardware. Measure the width across the nut and add a fraction of an inch to that dimension. This will be the gap that you want to leave in the center of the post. The square nut will need to move freely up and down the gap, but not turn in the space.

Form the post by ripping the board into three lengths, with the two outer pieces being equal in width, and the center piece being the same width as the nut. Then crosscut the narrow piece into two $1\text{-}\frac{3}{4}$ "-long pieces. Glue those between the long outer sections and your post is almost complete.

Once the glue has dried, remove it from the clamps and run it through your planer to fine tune the thickness. Trim the post to length and move on to the sleeve.

The sleeve is formed by cutting the pieces to size, then simply gluing the four pieces together to form a rectangular column. Be careful to align the pieces to avoid cleanup and provide a square (and glue-free) center sleeve.

Lock-n-slide

The locking mechanism for the post is a length of threaded rod with nuts, a couple of fender washers and a handle slipped through the column. To make the clearance holes in the column, measure down $1\text{-}\frac{1}{2}$ " from the top on the front side and make a mark in the center of the column. Take the column to your drill press



4 Some simple hardware from your local home center store allows you to lock the post solidly, but quickly loosen the post and readjust for any height. The hardware is shown at right, resting on top of the column before being attached through the holes.



5 This shot shows the partially assembled table, with three exposed dividers and the other side covered with the top. You can also see the screws through the bottom that hold the mounting blocks in place. While the box itself is nailed together, the fence is attached with screws to allow for replacement if it gets cut up too much in use.

and, using a 5/16"-diameter drill bit, drill completely through both sides of the column.

Now switch to a 1-1/2"-diameter Forstner bit and, using the 5/16" hole on the back side as your center, drill a larger hole in the back.

The rest is hardware. Spin the two hex nuts onto the end of the threaded rod and use wrenches or pliers to tighten the nuts against one another to lock them in place. Then slip one fender washer on the long end of the rod and against the pair of hex nuts.

Now thread the square nut on after the washer and tighten it against the washer and hex nuts. Insert the assembly (long end first) into the larger hole in the back of the column, threading it into the center slot in the post (which you've slipped into place).

When the threaded rod pokes out the 5/16" hole on the front side, add another washer and the star handle. You're done. Make sure the square nut is rotated to slip into the slot to make a tight fit.

Add the Feet

The last part of the base is the feet. These are just four boards screwed to the bottom of the column. I trimmed a long taper on the top of each to make it a little more aesthetically pleasing.

When you drill the clearance holes for the screws, pay attention to where the screws are located, or you'll end up drilling into another screw. Offset them slightly and you'll be fine.

With the feet attached, I added four adjustable leveler feet to make sure the stand would sit solidly on my uneven garage floor.

Torsion-box Top

I wanted to make the top of the stand as lightweight and strong as possible, but still stable. To accomplish this I used ½"-thick Baltic birch plywood and built an open-front torsion box.

Before making the box, locate the center position on the bottom plywood piece and mark where the top of the post will meet the box. Then screw two 1-¼" x 1-¾" x 5" solid-wood blocks to the underside of the plywood, centered and on either side of the post's location. Use these two mounting blocks to attach the table to the post after you have completed the table.

To form the box, simply assemble it with a brad nailer, making sure to align all the edges to keep things square. The two tops are held flush to the outside ends, leaving a 3"-wide gap in the center to allow plenty of room for a circular saw or jigsaw blade. The space in "the valley" ends up at a 2-½" depth, which should allow clearance for almost any jigsaw blade and lots of room for the blade of a circular saw.

With the table frame complete, nail ½" x 2" x 4-½" backs into the spaces at the rear of the box, closing up the opening. The hardwood fence is next. Drill four clearance holes and screw the fence to the back of the box, screwing into the backs.

To avoid any concern of binding a saw blade during the first few uses, cut a notch in the fence 1" wide and as deep as the blade depth you're

most likely to use.

You're now ready to attach the table to the base. Drill clearance holes in the center of the mounting blocks under the table, then screw the table to the post.

A Little Something Extra

The roller is really inexpensive, and is quick to put together and attach. Simply drill two $\frac{1}{4}$ " clearance holes in the 1-1/8" x 2" x 9-1/2" roller block, 1-1/2" from each end, and centered on the block. Use a $\frac{1}{2}$ "-diameter drill bit to countersink the top of the holes to fit the head of a machine bolt and a locking washer. Then flip the block over and use a 1-1/2" Forstner bit to countersink the bottom of the hole to accept a hex nut.

Before attaching the hardware, place the block in the table valley and use a pencil to mark the hole locations on the table bottom. Then drill oversized $\frac{1}{4}$ " holes at those locations.

With the bolts inserted and tightened down, screw the roller mounting brackets in place on the block. The ends of the bolts will slide easily into the holes in the table, and the roller can then be attached using two wing nuts. When the roller isn't needed, it fits snugly inside any one of the open-end spaces in the table.

No matter where you use this stand, you'll find rough-cutting lumber a more pleasant experience. I'm pretty sure there are a few other uses for this stand as well. Just give me some time. **PW**

David Thiel is a senior editor at Popular Woodworking.

Popular Woodworking



Articles & Plans

[Free Project Plans](#)

[Select Articles](#)

[Searchable Links](#)

[Magazine Extras](#)

Books

[Bookstore](#)

[Woodworker's Book Club](#)

Store & Services

[Subscribe](#)

[Buy Back Issues](#)

[Gift Subscription](#)

[Plans For Sale](#)

[Article Index](#)

[Customer Service FAQs](#)

[Subscriber Services](#)

Other

[E-mail Newsletter](#)

[Free Information](#)

[Advertising Info](#)

[Contact the Staff](#)

[Home](#)



Download a construction drawing



Arts & Crafts Globe Stand

Nothing decks out your library like a proper globe stand.

As was the case with most Americans, my world became a larger place last fall. I began to realize that I had only a vague notion of the location, size and geographical relationship of many of the countries whose names dominated the nightly news. Since I always had a problem with the Mercator projection maps that colored the walls of my high-school classrooms (is Greenland really as large as the United States?) I knew that a globe was the only thing that would give me a clear understanding of what's what and where.

When I visited my local map store, the globe-stand selection ran the gamut from traditional nautical themes to modern metal sculpture. What I was really looking for, a simple Arts & Crafts-inspired piece, was lacking from the lineup. I decided that the only way that I would be happy with the new addition to my living room was to buy a globe separately and come up with my own base.

Paging through a few of my Arts & Crafts books, the taboret (essentially a small table) appeared to be a staple of the founding fathers of the movement. From Limbert to Mackintosh, Stickley to Wright, there always seemed to be room for yet another small table. With all its variations, it was the perfect starting point for a globe stand. With a little stretching here and a little cutting



1 Use the plans from the diagrams to lay out your mortises on your top pieces. Draw the mortise locations on paper, photocopy the plans and use rubber cement or a spray adhesive to attach them to your wood. Then it's simple matter of cutting where the lines tell you to.



2 After you've cut your top to size, you need to clean up the band-sawn edges using a router table, a straight bit and the shop-made jig shown here. First cut a piece of 1/4"-thick plywood to the same size as your top and attach it to the top using a spray adhesive. Nail the center of the 1/4" plywood to a sub-base of 3/4" plywood. My router table is part of my table saw setup, so I attached a miter bar to the 3/4" plywood, which allowed me to slide the jig into position. If you don't have a miter slot, you might need to first clamp the jig in place and raise the router bit while it's running to get your cut started.



3 Once you get the outside shaped perfectly, you can use that edge to guide your router. I used a commercial edge guide (the [Micro Fence](#)). Essentially, two

there, I soon had enough designs to house a galaxy, or at least a small solar system, of globes.

The Stickley variation that I finally built incorporates a lot of the “tricks” – through-mortises, half laps, chamfered and pegged through-tenons, pyramids, and corbels. As it turned out, it was a great project for developing my Arts & Crafts joinery skills. Because all the parts are small, and a limited amount of material is involved, I didn’t become suicidal when a mistake condemned a piece to the kindling bin.

I strayed from the quarter-sawn white-oak norm and chose to use cherry to build the stand. Aside from cherry’s tendency to scorch when being cut, it’s a pleasure to work, easy to finish and, in central Ohio, the price is right.

Around the World in Four Easy Pieces

Start by laying out the four top quadrants. With the exception of the legs, all the parts for this project are sized to be cut from 1 x 6 stock. Before turning to your band saw to test your eye/hand coordination on the outside curves, cut the 1" x 1" mortises. They’re easier to form when there are still flat sides to press against a fence.

While splined joints might have been another “trick” that I could have thrown into the mix, I opted for the ease and familiarity of biscuits when assembling the ring. After gluing up the ring, cut the arcs slightly wide of the line on the band saw. I used a shop-made circle-cutting jig on my router table to refine the outside edge. Then I used a router edge guide to trim the inside edge to a perfect circle.

rounded guides ride along the outside edge of the top, ensuring the straight bit cuts a perfectly circular path. You also could make this cut using a commercial or shop-made circle-cutting jig for a router.



4 Though there are many complicated ways to attach corbels to legs, I prefer to simply glue and clamp them in place.



5 Here’s a close look at the notches in the top that hold the pins on the globe.

I also used biscuits to join the two halves of the lower table. I added another level of detail with a $\frac{1}{4}$ " x $\frac{1}{4}$ " chamfer on the top edge of both the ring and table. Finally, I plowed two $\frac{1}{4}$ "-deep x $\frac{3}{4}$ "-wide grooves that crossed in the middle of the bottom of the table to position it squarely on the stretchers.

The legs are formed from 2 x 2 stock. Although the $\frac{1}{2}$ " x 2" through-mortises were made on the legs with a straightforward series of cuts with a $\frac{1}{2}$ " mortising chisel, the through-tenons required some attention to detail. After cutting the tenons on the ends of the legs to fit the mortises, I determined that a 14° bevel would give me an $\frac{1}{8}$ "-high pyramidal top. The tenon is sized to allow for an $\frac{1}{8}$ " vertical rise above the top before transitioning into the slopes. I like the look, and it's more forgiving than trying to align four pyramid bases exactly with the tabletop.

The stretchers are joined with a simple half lap. The ends of the through-tenons are chamfered at a 45° angle. I then pegged each tenon using $\frac{3}{8}$ " cherry dowels through $\frac{23}{64}$ " holes after slightly tapering the ends of the dowels. With the holding power of contemporary glues, they're only for show anyway.

Speaking of show, the corbels that "support" the top are structurally unnecessary to this project. Visually, however, they're the icing on the cake. Glue them in place and clamp them up.

To mount the globe on the stand, you need to cut two $\frac{1}{4}$ "-long x $\frac{1}{4}$ "-deep notches in the inner edge of the ring. Rather than setting up my router and a jig for the operation, I

chucked a ¼" Forstner bit into my drill press, made a ¼"-deep hole that was tangent to the inner edge, and squared up the bore with a sharp utility knife. See the photo at left for details.

Because cherry darkens quickly enough through oxidation and exposure to ultraviolet rays, I used a clear wipe-on oil finish to emphasize the contrast between the end grain of the through-tenons and pegs and the face grain of the legs and top. If you've got 'em, you might as well flaunt 'em. **PW**

Dan Brody is a home improvement contractor in Columbus, Ohio.

[Return to Free Projects Plans](#)

© **Popular Woodworking** • [F+W Publications Inc.](#)
[Customer Service FAQs](#)

Popular Woodworking



Articles & Plans

Free Project Plans

Select Articles

Searchable Links

Magazine Extras

Books

Bookstore

Woodworker's Book Club

Store & Services

Subscribe

Buy Back Issues

Gift Subscription

Plans For Sale

Article Index

Customer Service FAQs

Subscriber Services

Other

E-mail Newsletter

Free Information

Advertising Info

Contact the Staff

Home



Download a construction drawing



Shaker Storage Cabinet

Maximize storage space in any cabinet with a couple of simple tricks.

The Shakers always had a knack for packing a lot of storage into a small space and making it look good. The three-sided built-in in the Center family residence at Pleasant Hill, Ky., is a prime example. You've probably seen a photo of it. It's the impressive cherry unit that's in an attic with a skylight that illuminates all 45 drawers.

It is in that spirit that I designed this two-door cabinet for a client in Ohio. The family needed to store an enormous number of board games and toys in a small space. The doors had to hide everything.

How to Pack Lots of Stuff Into Small Spaces

Organizing clutter is an interesting problem that you also might face as you design storage in your home or case pieces. Here's what I did: Behind the left door I put a series of five $\frac{3}{4}$ "-thick adjustable solid-wood shelves. These would handle the heavier games and books. Behind the right door is a series of $\frac{1}{4}$ "-thick tempered Masonite shelves. These 10 shelves slide in and out of $\frac{1}{4}$ " x $\frac{1}{4}$ " dados.

The Masonite won't hold a lot of weight, but it's just right for storing lightweight objects. Think home office, and you'll know what I mean. Masonite (sometimes called "hardboard") shelves are perfect for storing letterhead, envelopes, CDs and any other paper goods in an



1 Behind the left door are five $\frac{3}{4}$ "-thick adjustable solid-wood shelves, perfect for heavier games and books. Behind the right door are 10 $\frac{1}{4}$ "-tempered Masonite shelves, perfect for storing letterhead, envelopes, CDs and other home-office related items.



2 I'm not perfect, and neither are you. If your face frame is exactly the width of your case, it's going to be difficult to fasten it square. Make life easier by ripping your stiles $\frac{1}{16}$ " oversize in width. After you nail and glue the face frame to the case, use a flush-trimming bit in your router to trim the face frame flush with the side of the cabinet's case.

office. The other challenge in this piece was getting the shelves, doors and face frame positioned so they didn't interfere with one another. As you'll see in the drawings, it took a few pieces of "blocking" to get everything to work in this cabinet.

Face Frame First

This seems backwards, I know, but begin construction by building the face frame. The size of the case and doors are determined by your face frame, so it's clearly the place to begin.

When ripping out the material for the face frame stiles, cut them each about 1/16" wider than the dimension called for in the cutting list. This will make your face frame hang over the edge of the case sides. Once the face frame is attached, you can trim it flush for a perfect fit.

I use mortise-and-tenon joinery to build both the face frames and doors. The tenons are 3/8" thick and 1" long, and I usually cut a 3/8" to 1/2" shoulder on the edges. Be sure to cut your mortises 1-1/16" deep so your tenons don't bottom out. When everything fits, put glue in the mortises, clamp the frame and allow the glue to cure.

Doors are Second

Next, build the doors. It's much easier to fit the doors into your face frame before it's attached to the case. Build the doors much like you did your face frame by using mortise-and-tenon joints. The only difference is that you need to cut a 3/8" x 3/8" groove in the rails and stiles to hold the door panels.



3 You can see the haunch on the tenons on the rail closest to the camera. When it comes to fitting your panels, remember to work tight in summer and loose in winter. Panels of this size will shrink and contract noticeably.



4 You could use a router and a straight bit to make this cut as long as you had a reliable way of guiding the router (such as an edge guide). I find a table saw is much faster for this operation.



I cut my grooves along the entire length of the stiles; as a result, I cut my tenons with a “haunch” to fill in that extra space on the ends of the stiles. The panels are flat on the front, and beveled on the backside so they fit in the grooves in the rails and stiles. I cut that bevel by setting my table saw blade to 7° and slicing off a little of the backside of each door until the panels fit snug and without rattling.

Sand the panels up to your final grit (120 will be fine for a painted piece) and assemble the doors. Sand the assembled doors and face frame and then peg the tenons if you like. I used square pegs that I pounded into round holes.

Finally, the Case

The case goes together quickly thanks to my nail gun. Begin construction by cutting a ¾"-wide by ¼"-deep dado in the side pieces for the bottom of the cabinet. I like to use a dado stack in my table saw for this operation. Now cut a ½" x ½" rabbet on the back edges of the sides to hold the plywood back in place. Sand the inside of the case and get ready for the first bit of assembly.

Put the case together on its back. First put glue in the dados in the sides and fit the bottom in there. Nail the bottom in place from the outside of the case. I use a finish nailer for this task.

Now put the nailing strip in place at the top of the case. The diagrams show you where this needs to be, but essentially it's flush with both the rabbets in the sides and top of the case. Nail it home. Glue and nail the face frame to the case using brads. Trim the face frame flush to the

5 Once you nail the dividers in place through the bottom piece, turn the case over on its feet and nail through the nailing strip into the dividers.



6 In addition to cutting this detail on the sides and front, I also cut it on the bottom of the plywood back, which gives it a finished look when the cabinet is viewed from down low or from a distance.

case.

All the Insides

There's nothing complicated about the insides once you have a plan. Begin by cutting the ¼" x ¼" dados in the dividers. These are spaced 2" apart, and there are 21 of them. I used a dado stack in my table saw and simply moved the fence 1-¾" after each pass.

Now it's time to add the dividers to the case. Turn the case on its head. Cut a notch in each divider so it will fit around the nailing strip. Get the divider right where it needs to be and nail it in place through the bottom and the nailing strip. Now nail the two blocking pieces shown on the diagram in place. The blocking does a couple things. First, it allows the Masonite shelves to be slid in and out without having to swing the doors wide open. Second, the thinner piece of blocking fills in the gap between the divider and face frame and leaves room for the hinges.

Now drill the holes in the left side of the case and the center divider for the adjustable solid-wood shelves. I'm partial to 5 mm holes spaced 1-3/8" on center.

Mark the base cutouts on the sides, front and plywood back of the case using the diagrams as a guide. Use a jigsaw to make these cuts and clean up your work with sandpaper.

Cut your top to size. I used a piece of bird's-eye maple. You have a couple options for attaching the top. You could use pocket holes, figure-8 fasteners or wooden cleats. No matter which way you go, prepare the case for the top but don't attach it. I like to glue the top to the front

edge of the case after finishing.

Finishing

On the knobs, top and all the inside pieces (except the Masonite), I wiped on a light honey-colored stain. Then I painted the case a dark red and added a topcoat of lacquer to protect the paint. Hang the doors, nail in the back and add the knobs. The hinges I used to hang the doors are available at [Woodworker's Supply](#). The maple knobs I used are available at [Horton Brasses](#).

I have no idea how the Shakers would feel about seeing one of their cabinets filled with “Parcheesi,” “Connect Four” and “Uncle Wiggly” games. But I’m sure at least they would approve of the efficient use of space. **PW**

Troy Sexton is a contributing editor for Popular Woodworking.

[Return to Free Projects Plans](#)

© Popular Woodworking • [F+W Publications Inc.](#)
[Customer Service FAQs](#)



Articles & Plans

Free Project Plans

Select Articles

Searchable Links

Magazine Extras

Books

Bookstore

Woodworker's Book Club

Store & Services

Subscribe

Buy Back Issues

Gift Subscription

Plans For Sale

Article Index

Customer Service FAQs

Subscriber Services

Other

E-mail Newsletter

Free Information

Advertising Info

Contact the Staff

Home



Download a construction drawing



European Telephone Console

Keep your phone, phone books, keys and small umbrellas in order.

Being worldly woodworkers, the *Popular Woodworking* staff spends time checking out woodworking ideas from Britain, Australia and even Germany. It was in a German woodworking magazine called *Selbst* that we saw a similar entry hall stand. Its clean lines and utilitarian efficiency caught our eye, so we decided to give it a little American schooling and share it with our readers.

Two Triangles

I was able to get all the necessary parts (except the back) out of a 4' x 4' piece of cherry plywood. Start construction by ripping two 12½"-wide pieces from the sheet of plywood, then crosscut the pieces to 38" long. Next, strike a pencil line from one corner, 12" from what will be the back edge, and connect it to a point on the opposite corner, 1½" from the same back edge. Mark both pieces, making sure you have left- and right-facing pieces.

Head to the band saw with the two pieces and cut along the pencil line, leaving about an 1/8" wide of the line. Then take the two pieces to the jointer and trim the angled edge straight and fairly close (1/16") to the line. To make the two pieces identical, clamp them together, flushing up the back and top edges. Using a sharp bench plane I made a few passes on the angled edge to even up the pieces.

Parts for the Middle

Grab what's left of your plywood



1 These first six photos show the sidebar "Iron-on Wood" below. Start with a piece of tape that's about 2" longer than the edge you are covering. Your iron should be on a cotton setting, with the steam turned off. Make sure the tape overhangs the edge evenly, then start ironing. Make long passes over the edge, not stopping in any one place for any length of time, applying heat evenly. The tape will start to curl up a little as the glue melts.



2 Since trying to use the iron to hold the tape in place as the glue dries just reheats the glue, switch to a simple block of wood. The chunk of poplar shown here works great. The bottom surface is sanded smooth and the edges are broken to avoid snagging or scratching. Simply apply pressure and make long passes over the edge for about 30 seconds. If you have a few pieces to veneer, set the first piece aside for now to let the glue cool.



3 To trim the edge, start by carefully bending over the ends until the veneer breaks. Make sure you apply pressure to the end of the attached veneer so it doesn't splinter back onto the visible edge. Then pull the "dangling chad" of veneer downward to

sheet and rip an 11"-wide strip from it. From this 11" x 48"-long piece you'll be able to get the door, the kick, the two cleats and the shelf. Crosscut all the pieces except the shelf to size. The piece that is left is enough to make the shelf, but I turned the shelf so the grain would run longways to better match the veneer tape. Go ahead and cut the shelf to size now.

Now it's time to disguise the plywood as solid wood. The front and top edges of both sides receive iron-on veneer tape, as well as the front edge of the shelf, the top edge of the kick and the top edge of the lower cleat. Don't tape the door edges until the case is assembled. If it's your first time using veneer tape, see the instructions on the next page.

Put it All Together

There are a couple of joinery methods you could use to join the pieces together, but I chose biscuits. Start by marking the location of the shelf on the two sides and cut those biscuit slots. Then mark the location of the upper cleat to biscuit it to the underside of the shelf and into the two sides. The lower cleat is biscuited flush to the back edge and bottom of the sides, while the front kick is flush to the bottom edge, but held in 1/8" from the front edge to add shadow lines and to keep you from having to align the door perfectly with the edge of the cabinet. With all the biscuit slots cut, sand the inside faces, add some glue and clamp the piece together. Though there's little chance of the piece racking, check it for square.

After the glue is dry, remove the clamps and roll the piece onto its

tear it free. By the way, if you're doing four edges of a board, do two opposite edges first, trim the edges, then apply the other two edges.



4 To trim the long edges of the veneer tape, the tool of choice is a mill bastard file. Start by flushing the ends you just broke over, keeping the file flat to the side, and using only a pushing stroke. It should only take a couple strokes to flush up the end.



5 To trim the tape edges, use the file again, working right to left against the edge. The best method is to start the file at the end of the tape and push lightly against the overhanging edge to start a curl of veneer breaking away from the edge. Continue rolling the curl along the piece, keeping the file angled forward and at a slight bevel to the veneer tape. Once the curl is knocked off, lightly file the bevel again to remove any excess.

face. Chuck a rabbeting bit into a router and cut a 3/8" x 3/8" rabbet in the back edge of the sides and in the top and bottom cleat. Cut a 1/4" back to fit the space and round the corners to let it drop into place. Don't put the back in yet as it's easier to finish and mount the door hardware with the back off. Go ahead and fit the door, then veneer all four edges.

Finishing Touches: A Clear Top and the Right Hardware

The door is held in place using a continuous hinge mounted to the kick. You should be able to catch six holes in the hinge. Start by mounting the hinge to the kick, then use the two center holes to attach the door. Check to see if the hinge location allows proper clearance. If not, back out your first two screws and use two other holes to scooch the door one way or the other. When you've got it right, plug the misaligned hinge holes with a toothpick and some glue, then redrill the pilot hole and put the screws back in. The door is held in place using a brass lid support and a magnetic catch.

The clear acrylic top is the last construction step, and it's fairly easy to install. Simply drill four shelf pin holes in the sides to allow a 3/8"-thick piece of acrylic to rest 1/16" below the top edge. The acrylic piece is available as a 12" x 12" piece from a number of catalogs as a router-table insert. Cut the piece close to finished size on the table saw, then sand the piece to a press fit a little at a time. To make the two visible edges presentable, file the edges flat, then sand through 360 grit to a near-perfect edge.

Two coats of clear finish will protect



6 The file is too aggressive for a finished edge, so trade it in for some 220-grit sandpaper and finish cleaning up the edge. You'll find some of the adhesive is stuck to the face of the board. This can be lightly sanded off, but proceed carefully to avoid sanding through the face veneer. That's all there is to it, but don't go using the clothes iron, buy your own for the shop!



7 With all the cross members cut, the biscuit joiner makes it possible to pull the project together. This photo also shows the two cleats in place at the top and bottom of the case.



8 Once the two side wedges are cut to rough size, trim them a little closer to accurate on the jointer. Once you're within about 1/16" of the finished line, clamp the boards together and get out a bench plane. With a little hand work the pieces will match up perfectly.

the wood, and the piece is ready to hang. The upper cleat works great as a mounting point using a couple of molleys in the wall. Add a few simple cup hooks to the backside of the door, and you've got a convenient place to hang fold-up umbrellas, keys or any other "near-the-door" items. PW

Sidebar: Iron-On Wood see first six photos

There are lots of reasons to use plywood in a project. Cost, weight, wood movement and even environmental considerations. But just because you aren't using solid wood, you don't need to give up the look of solid wood. Iron-on veneer tape has been around for a long while, but it has sort of a "cheap" reputation. I'm here to tell you it's worth a look.

Available in a wide variety of wood species, veneer tape is actual wood veneer with a heat-sensitive adhesive applied to the back. With the heat of a simple household iron and a few simple tools you can turn a piece of plywood into a finished and attractive piece of wood.

I've been asked about the durability of veneer tape. I can't honestly think of any application for solid wood where tape wouldn't hold up as well.

Follow the steps below for some tips to getting the best results from your veneer tape.

David Thiel is a Senior Editor for Popular Woodworking.

[Return to Free Projects Plans](#)

Popular Woodworking



Articles & Plans

Free Project Plans

Select Articles

Searchable Links

Magazine Extras

Books

Bookstore

Woodworker's Book Club

Store & Services

Subscribe

Buy Back Issues

Gift Subscription

Plans For Sale

Article Index

Customer Service FAQs

Subscriber Services

Other

E-mail Newsletter

Free Information

Advertising Info

Contact the Staff

Home



Download a construction drawing



Router Table-Mate

Everything you'd want in a router table for just \$50.

Commercially made router tables are everywhere these days. Some of them come with more gizmos and gadgets than a '59 Edsel. By the time you tally up all the add-ons, the price approaches a medium-duty shaper. Here's my short list of "must-have" features for a good router table:

- A table the size of a carrier deck.
- Compact design so it can store easily.
- A stout fence that's long and easy to adjust.
- Easy bit-height adjustment with no stooping.
- Great dust collection.
- A \$50 price tag.

With all these features in mind, I hit on the idea of using my folded-up Workmate stored under the stairs. Can't I just make a top for it? Then I remembered the great idea from Contributing Editor Nick Engler in our January 2000 issue. Nick made the top of his router table tilt up for easy adjustments. Bingo. Now my Workmate/router table goes right back under the stairs and takes up only another 1½" of space, the thickness of the router tabletop. You can also use this router table without a Workmate. A simple pair of sawhorses will suffice.

Customizing Your Table



1 A larger base for the router was the ticket for bridging the open areas left by routing out the plywood for the router's base. It was later used as a small circle cutting jig for the tabletop and plastic inserts. Use the same cutter and it's easy to keep track of dimensions for cutting inside or outside circles.



2 Another illustration of the first photo.



3 Once the tabletop is hinged to the Workmate's front board, it's easy to locate the the positions for the prop stick and stick bracket. Note the shop-made replacement board for the Workmate top.

While the fence is generic to any router table setup, the table needs to be customized for your needs. You may have a different brand router than mine, so you will have to relieve the underside of the table to accommodate the shape of your tool. You'll have to locate the mounting holes for the base to suit your router. You may prefer a different table height. If you are below average height, you'll want to make the angle at which the table props up less steeply.

The top is made from two pieces of $\frac{3}{4}$ " birch plywood that are glued together and banded with $\frac{3}{4}$ "-thick solid birch. Before gluing anything together, it's best to work on the top plywood piece. Since you must rout out the underside of this top piece where the router base will be mounted, do it before gluing the two sheets together. The hole in the bottom sheet can be simply cut with a jigsaw. First, lay out where you want your router base to be mounted and find the exact center of the base. I put the centerpoint on my table 8" in from the back edge and centered right to left. So once the point is established, drill a $\frac{1}{16}$ " hole straight through to the other side. You'll need this location for work later on.

Now set up a router with a circle-cutting jig and a $\frac{1}{2}$ " straight bit. Set the bit so it will cut to a depth that will leave a $\frac{3}{8}$ " thickness in the plywood top. Cut a circle (assuming your router has a round base) on the underside of the top that is approximately $\frac{1}{4}$ " larger in diameter than the router base. Place the circle jig's indexing pin in the center hole you just drilled. Rout the circle and the remaining waste inside the circle.



4 As you assemble the fence, make sure it is square along its length. Be sure and check it again after it is clamped up.



5 Inside view of the dust chute from the rear including the plastic 4" to 3" dust collection hose adapter. Rout the 3" hole for the adapter with the circle-cutting jig or use a "fly cutter" in your drill press.



6 Break in your router table by milling the slots in the fence subfront that will allow the fence faces to adjust into or away from the router bit. Lay out the stop/start lines and plunge cut the slots.



7 Attach the fence faces using $\frac{3}{8}$ " roundhead machine screws, a star washer, flat washer and wing nut. I tried

Next, turn the plywood piece over. Use your center hole and circle jig to cut a 1/8"-deep circular rabbet or ledge for your plastic inserts to fit into. The insert diameter is 4-3/4". But before you use this insert size, check the size of your router's base. You may need to make a smaller-diameter insert based on the size of your router base. The router I mounted in the table is a massive Porter-Cable 7518. I made the insert hole size large enough to accommodate the largest diameter router bits.

using hex-head bolts but switched to screws because a screwdriver can be used and makes a more secure attachment with less trouble.

Now make the hole the router bits pass through. Leave a ledge about 1/2" wide all around for the removable inserts to rest on.

Now take the second sheet of plywood and jigsaw the cut to accommodate the router base. Also, make any cuts necessary to allow for your router base's handles. When done, glue the two sheets together. Keep the edges flush.

When the glue is dry, trim the top to finished size on the table saw. Now prepare some stock for the solid-edge banding. Miter the corners and glue it on. Make sure it is flush to the top. When dry, sand everything flush, then rout a roundover profile on the top edge.

Tabletop Inserts

Make the round tabletop inserts from 1/8" acrylic. I made three inserts to cover most of the router bit sizes I'd encounter. First set the circle jig to cut a circle that is the same size as the insert hole. Set your router to make an outside cut instead of an inside cut. To rout the acrylic, just drill a hole to accommodate the circle-cutting jig's

pin or nail.

The three hole sizes I made in the inserts were 1", 1- $\frac{3}{4}$ " and 2- $\frac{3}{4}$ ". The smaller holes were drilled using hole saws but the larger size required the circle-cutting jig.

Complete the Top

To fasten the inserts to the table, install three threaded inserts in the rabbet. I used inserts for a 6/32 flush machine screw. Once installed, transfer their locations to the acrylic inserts, then drill and countersink the plastic.

Next make a new piece to replace the rear board on the Workmate's table. The homemade board is narrower and allows the router to swing up unencumbered. Cut the board to the dimensions given in the materials list and locate holes that match those in your existing Workmate. The new board is slightly shorter than the original. Install the Workmate connecting hardware and place the board in the furthest connecting hole of the Workmate.

On the underside of the router tabletop you'll need to install a piece of $\frac{1}{2}$ " material where the stick that supports the top in the open position locks in place. I used a $\frac{3}{4}$ " dowel for a prop stick and drilled an oversized hole on a 25° angle in the block to nest it.

As mentioned earlier, the length of the prop stick will depend on how tall you are. On the end of the stick opposite the 25° angle, drill two holes that intersect each other to allow the stick to pivot in two directions, side to side so that it can be lowered when not in use and angled to allow you to tip it forward

when propping the tabletop. Use a stout wood screw, a #10 or #12, to connect the prop stick to the edge of the new shop-made top board.

Next use a pair of hinges to connect the top to the Workmate's front board. Locate them about 4" in from each end.

Now Make the Fence

Keep in mind the most important factor in making the fence is that it is straight and square to the table. It could be shimmed later, but you'll be fussing with it forever.

Start by laying out the full size shape of the bottom piece on the material you will actually use. Be sure you have a true, straight edge for what will be the front.

Go ahead and lay out where the dadoes will be cut, including where the half-round throat opening for the router will be. It's best to do the layout by first establishing the center of the length of the fence and working out from there. When done, cut the back shape. It need not be pretty.

Next cut out the two subfronts for the fence. Install your dado blade on the table saw to cut the thickness of the Baltic birch.

Now set the dado blades to make a 1/8"-deep cut. While holding the front edge of the fence bottom against the slot miter gauge, cut the six dadoes, following the layout lines already marked. When done, cut the center dado on the subfronts making sure it locates precisely where the dado in the bottom falls. Next raise the dado set to cut 3/8" deep and

run the rabbets on the ends and bottom of the fence subfronts.

Remove the dado and cut the fence ribs and pieces that make up the dust collection chute. Use the diagram for the shape. Before assembling the fence, cut the half circle in the fence bottom for the throat opening, then use a rasp to slope the back edge for more efficient dust evacuation.

Assemble the Fence

Be careful when you assemble the fence to make sure it goes together square. First dry-fit all the parts to be sure you have a good fit. Then glue the ribs and dust chute sides to the bottom, making sure all the edges are flush to the front edge. If you have a brad nailer, set these in place with a couple short brads. Glue the fence subfronts to the bottom and ribs. Clamp front to back until the glue dries.

Now cut the three remaining dust chute parts: the top, angled top and back. Cut a half circle in the top similar to the one in the fence bottom. After the glue in the fence assembly has dried, glue the dust chute top in place. Afterwards, install the angled top and the back piece. The angled top requires a steep angle cut on the lower edge to seat down to the flat top. I cut this angle on my band saw. The back of the chute requires a hole for dust collection. The chute is set up to take a 3" hose or a fitting that reduces a 4" hose to a 3" hose. I used a "fly cutter" in my drill press to make the 3" hole. To complete the assembly of the dust chute, screw the angled top, then the back in place.

Use Your New Router Table

Now use your router table to mill the slots in the fence's subfronts that allow the fence fronts to slide left to right.

Set your router in the table with a 3/8" straight bit. Make a temporary fence from a straight piece of scrap and clamp it to the tabletop. Use the fence diagram for setting the distance. Cut the 2"-long slots in the center of the openings between the ribs.

Make the adjustable fronts from a tight-grained hardwood such as maple. Be sure the material is flat and straight. Cut the two pieces to the lengths given. Make bevel cuts on the ends as shown in the diagram. Carefully locate the hole locations where the 3/8" machine screws attach the fronts through the slots in the subfronts. Drill and countersink the holes. For attachment, I used the screws along with star washers, flat washers and wing nuts.

The last detail is to cut a small piece of acrylic as a "window" on the top of the dust chute into the router opening area below. PW

Steve Shanesy is Editor for Popular Woodworking.

[Return to Free Projects Plans](#)

© **Popular Woodworking** • [F+W Publications Inc.](#)
[Customer Service FAQs](#)

Popular Woodworking



Articles & Plans

Free Project Plans

Select Articles

Searchable Links

Magazine Extras

Books

Bookstore

Woodworker's Book Club

Store & Services

Subscribe

Buy Back Issues

Gift Subscription

Plans For Sale

Article Index

Customer Service FAQs

Subscriber Services

Other

E-mail Newsletter

Free Information

Advertising Info

Contact the Staff

Home



Download a construction drawing



What You Must Know About Shelving

Learn the simple but important rules to building sturdy shelves.

Building shelves for muddy boots or a Chippendale secretary seems deceptively simple. First you install a horizontal surface between two sides. Then you load up your newly built shelf with Wellingtons or glass kitty cats. Finally you stand back and admire your work.

Then one day you decide to put encyclopedias on your shelf after you grow weary of the kitties. The shelf sags. The books don't fit under the shelf above, and the books' spines hang over the front edge. And you wish you had used a more rigid material and some sort of adjustable shelf pins so you could change your shelves to fit your needs.

Shelves, as you might have guessed, are not as simple as they appear. That's not to say they're hard to build. It's just that there's a whole set of rules to properly design bookshelves or display shelves that ensures they will hold a wide variety of common objects.

This shelving unit is the perfect tutorial for etching these rules on your brain. You'll see how I followed the rules to design this project, and you'll get a down-and-dirty lesson in how to build shelving units that are quick, easy, rock solid and good-looking. First, here are a couple rules of thumb when you're putting your design on paper. It's accepted practice to build your cabinets in 3" increments. For example, the side units are 24" wide. If I wanted to make them wider, I'd jump to 27" wide, then 30". Another rule of thumb is that whenever a cabinet



1 Drill your shelf pin holes before you assemble your case. I like to put mine on 1" or 2" centers. Depending on what you're going to put on your shelves, you might not need that many holes.



2 Get a friend to help you stack the cases on top of one another.

gets 42" wide, it needs a vertical support in the center. My cabinets are less than that, so that was no problem for me.

Where to Begin: Face First

This large wall unit is essentially six plywood boxes with solid wood face frames on front. The part of the back that is visible behind the shelves is solid wood. The back behind the doors is plywood.

When building shelves, it's tempting to begin with the case because it goes together really fast. Resist this temptation. Begin your project by building your solid wood face frames. Your entire project is based off your face frame, so if you've got a problem with your design (or how you milled your parts) you're most likely to find out about it when you build the face frame. And I'd rather throw away a skinny piece of solid wood than a sheet of ply.

I make my face frames using $\frac{3}{4}$ " material (which is the standard) and mortise-and-tenon construction. First I cut my tenons on the rails, then I use those to lay out my mortises on my stiles. When working with $\frac{3}{4}$ " material, I always make my tenons $\frac{3}{8}$ " thick and 1" long. Usually I'll cut a $\frac{1}{2}$ " shoulder on the width of the tenon, but if the stock is narrow (less than 3") I'll use a $\frac{1}{4}$ " shoulder. I cut my tenons on my table saw using a dado stack. Now lay out your mortises using your tenons. Cut your mortises (I use a hollow chisel mortiser) about $\frac{11}{16}$ " deep so your tenon won't bottom out in the mortise. Put glue in the mortises, clamp and set your face frames aside.

Plywood Boxes



3 Then use spring clamps at the back to hold everything together as you screw the upper cabinets together and the lower cabinets together. Be sure to screw right behind the face frame so the screw is less visible.



4 Attach the waist mould using nails. Nail it to the lower case and allow the top edge to cover the seam between the upper and lower cases.

Make the cases out of $\frac{3}{4}$ " plywood. Cut $\frac{3}{4}$ " x $\frac{1}{4}$ "-deep dadoes on the sides to hold the bottom pieces. These should be flush to the top edge of the bottom rail. Cut $\frac{3}{4}$ " x $\frac{1}{4}$ " rabbets in the top edge of the side pieces to hold the top. This is also the time to cut the grooves in the sides of the center cabinet to line up all three cases. Read "Another Face Frame Trick" on a previous page for details. Now cut rabbets on the sides to hold the back. The size of the rabbet is determined by whether it's a plywood back or a solid back.

Now drill your adjustable shelf holes. I use a commercial jig, but you can make a template yourself from plywood. I drill my holes every 1" or 2" on center, which will allow a lot of adjustment. (The standard is to drill them every 2" on center or less and within 6" of the top and bottom of the cabinet.) For years I used shelf pins that required $\frac{1}{4}$ " holes. Then I switched to metric 5 mm because they're less conspicuous.

Now sand the inside of your case pieces with 180 grit sandpaper to knock off the fuzz and splinters. Be careful not to cut through the veneer face.

Go ahead and put your cases together. Put glue in the dadoes and rabbets and nail through the outside of the cases into the top and bottom. Putty the nail holes. You don't need to clamp the case.

Now attach your face frames using glue and nails. Trim the face frames flush (see "Perfectly Flush Face Frames" on a previous page) and putty your nail holes. Now sand your face frames. I begin with 100 grit, then 120, 150 and finally 180. Sand



5 Here you can see what the shelf moulding looks like close up. Nail and glue the moulding to your plywood shelves.

the outside of the plywood case beginning with 120 grit and work up to 180.

If you're going to add columns to your center case, cut the details using a fluting bit in your router and attach the columns to your face frame with glue.

Finally, screw all the top units together and then screw all the bottom units together. Then turn your attention to the moulding.

Many Mouldings

There are five types of moulding: • The crown mould. Buy it pre-made from a hardwood supplier. • The ½" cap on top of the crown mould. This is simply square stock with a 3/8" roundover cut on one edge. • The waist mould. This covers the seams between the upper and lower units. You can buy stuff like this off the rack, or you can make it. First cut your stock to size. Then use a beading bit to cut the center bead. Then use a ½" cove cutter in your router to cut the coves on the top and bottom. Be wary that as you make the second cove cut the moulding won't be as steady. • The base mould. This is flat stock with a ½" cove cut on one edge. • Shelf moulding. This goes on the front edge of the plywood shelves (which you'll make later). I used a rail and stile bit to make this mould in two passes. You also could use a Roman ogee bit and get the same effect. Cut a shallow rabbet on the back as shown in the photo at right. Hand sand all your moulding before applying it. Attach the moulding with glue and nails. Start from the center and work out. One word about the waist mould. Position it so it sticks up ½" above the lower case (see

photo at right) and nail it to the lower case.

Doors

Build the doors the same way you built the face frames with one exception. You'll need to cut a 3/8" x 3/8" groove on the rails and stiles for the solid wood panel. That also means you'll need to cut haunches on your tenons to fit into the grooves.

With raised panels I allow a 1/8" gap on each side so the panel can expand and contract in the groove. To "raise" the panel, first cut the approximate angle on the panel's edge using your table saw. Then use an 8-degree raised panel cutter in your router to raise the panel. This way you'll only need to make one pass on your router table. Sand the panel, assemble the doors, then sand the rest of the door. Peg the tenons, cut the pegs 1/16" proud and sand them smooth but not flush to the doors.

Attach the pulls and fit your doors so there's a 1/16" gap all around. I use Amerock adjustable non-mortise hinges. These hinges are pricey (about \$3 each) but they are worth every penny because they are simple to install and are adjustable. See the Supplies box at the end of the story for details.

Back and Shelves

I used a shiplapped and beaded 1/2"-thick back on the top part of the case, and a plywood back on the lower section. Cut your 1/4" x 1/2" shiplaps, then cut the bead on the edge using a 1/4" beading bit in your router. Fit the back, being sure to

leave space for seasonal expansion and contraction. Don't nail the back in place until after finishing.

Cut your shelves from plywood. Nail the moulding to it. Sand the shelves.

Finishing

I used a clear finish on this piece, sanding between coats with 3M sanding sponges (fine grit). Nothing gets into moulding and raised panels better. When everything's dry, nail your back pieces in place and hang your doors. PW

Troy Sexton is contributing editor for Popular Woodworking.

[Return to Free Projects Plans](#)

© **Popular Woodworking** • [F+W Publications Inc.](#)
[Customer Service FAQs](#)

Popular Woodworking



Articles & Plans

Free Project Plans

Select Articles

Searchable Links

Magazine Extras

Books

Bookstore

Woodworker's Book Club

Store & Services

Subscribe

Buy Back Issues

Gift Subscription

Plans For Sale

Article Index

Customer Service FAQs

Subscriber Services

Other

E-mail Newsletter

Free Information

Advertising Info

Contact the Staff

Home



Download a construction drawing



Garden Swing

Nothing says summer like a glass of lemonade, relaxing in the shade and hoping to catch a breeze – or creating your own by giving your swing a kick. Of course, I always get so comfortable I'm looking for a place to put my drink down and close my eyes. Now I've got a swing designed to help. Integrated into the seat is a simple pop-up table that sits level to the ground while the swing keeps your back at a comfortable angle.



With the seat frame assembled, nailing the slats in place was a cinch with a pneumatic finish nailer and stainless steel nails. Note the 7-degree bevel on the rear of the back seat rail.

The swing is simple to build. Joinery consists of some simple tongue-and-groove construction, biscuits and screws. Most of the pieces are dimensional lumber sizes you can buy right off the rack. You will, however, need a planer to run the slats down to their proper thickness.



Holding the arched top rail steady was the most difficult part of routing the top groove for the slats. Remember to make the cut in two passes on each side. In this photo you can see that the rail hasn't been cut for length yet, allowing extra support for the router at the beginning and end of the cut.

Start the project by heading to the lumber yard. The six-foot swing as shown required one 2x8, one 2x6, five 2x4s, and 10 1x4s all in eight-foot lengths. I chose western red cedar because it's a durable, lightweight, outdoor wood and is less expensive than redwood. At Midwest prices, the lumber cost about \$120.

Seat Frame

Once back in the shop, start construction by cutting the seat rails and stringers from the 2x4s. As you probably know, dimensional lumber comes with rounded edges. You'll need to get rid of them. Cut the pieces for the rails and stringers to their 3" thickness by first running one edge over the jointer until they have a square edge, then rip them to 3" wide. To give the seat a comfortable back angle, set your saw blade to an 7-degree bevel and run the back rail on edge to give a 7-



With the miters cut on the top rail and back stiles, space the slats and use the top rail to mark the angle and length of each slat, (adding 1").

degree angle to the back.

Now cut the pieces to length and screw the stringers between the rails, spacing them as shown. The center section spacing is critical because the pop-up table needs to be square so it can be lifted out and turned in place and the legs lowered. Use 2" galvanized deck screws when screwing the seat frame together.

Mill all the slats at the same time because they are essentially the same size. Cut the 1x4s into 24" lengths, and plane the boards to 5/8" thickness. Then rip them to their 2½" width and crosscut the seat slats to 20". To give the swing a finished look, cut an 1/8" roundover on all four top edges of each seat slat using a bit mounted in a router table.

Attach the slats for the permanent seats, running the slats from side to side. They should flush up in length to the outside edges of the stringers, and the front slat should be flush to the front rail. Use about 3/8" spacing between the slats. I decided to attach the slats to the frame using finish nails and an air nailer. This left a much smaller hole than screws, and it was very quick.

To finish the seat I decided to build the top surface of the table at this point. The spacing works the same as on the side seats, but run the slats from front to back. The slats are attached to two table battens (¾" x 1-½" x 19-7/8") that are held 1/16" or so away from the inside face of the front and rear rails. This gap should allow the table to lift out without binding, but some slight fitting may be necessary. Don't worry about the legs yet, we'll do



The back of the arm is simply screwed in place through the back stile, while the support is attached to the arm and seat with dowels and polyurethane glue. Notice the foamy squeeze-out of the glue at the joints.



With the notches cut in the support cleats, the two pieces can be glued in place in the seat frame.



Last, but not least, bolt the table legs in place to the table battens. Note the notches

that later.

on the ends of the legs which drop into the previously cut notches to stabilize the table.

Build the Back

Next, turn to the back of the swing. Mill the bottom back rail and two stiles to size as described earlier to leave crisp edges. Run the bottom edge of the bottom back rail and both stiles through the saw at an 83-degree angle to match the bevel on the seat. Then take the 2x8 top rail and lay out the top arch of the swing by marking the center of the rail, then mark 2-½" down from the top at the center. Tap a small brad nail into the board at this spot, then put two more brad nails into the board at the bottom corner of the board at either end. Then take an eight-foot strip of ¼"-thick wood and bend it across the top nail, attaching the strip to the two lower nails with spring clamps. The arch formed by the strip can then be marked with a pencil, and then a second line (2-½" above the first line), marked. Jigsaw the piece to the outside of these lines, then sand the piece smooth.

To determine the length of the top rail, lay the bottom rail and side stiles flat with the bottom rail between the stiles. Clamp these pieces in place, then lay the top rail across the tops of the stiles, flush to the top outside corner of each stile. With the top rail in place, mark the point where the inside curve of the rail intersects the inside edge of the stiles. Connect the two points and this is the angle to cut on the top edges of the stiles and on the ends of the top rail, to form mitered joints. The back frame will be held together with a double helping of biscuits, but first you need to cut the groove in the top and bottom rails to hold the slats.

Running the groove in the bottom rail is fairly simple. Set up a router with a straight bit (or an up-spiral bit) of either 3/8" or 1/2" diameter. Next set up a fence on the router 7/16" from the bit, and set the bit for a 1/2" depth. (The final depth is 1", but take it in two passes.) By running the router on both long edges of the rail, the groove will be centered on the piece. Check the fit of the back slats in the rail (or better, a test piece), then make the groove.

To cut the same groove in the arched top rail, see the photo at left. You will need to adjust the depth of the final cut a bit to compensate for the curve of the arch.

Miter the top rail to length, then check the fit of your slats in the grooves. The spacing between the slats should be about 2-1/4", but double-check your dimensions.

After cutting the double biscuits at the joints, place the slats in the bottom groove and locate the top rail in position on the slats. Mark the height and curve on each slat. Remove the slats, numbering them as you do. Now add 1" in length to the marks on the slats and cut them to their finished length using the band saw. You're now ready to glue up. I used polyurethane glue for all my glued joints. The polyurethane adhesive provides a strong water-resistant bond in even long-grain to short-grain joints. Don't glue the slats in place, however. Place them in the grooves in their approximate positions, then after the frame has dried, use a brad nailer to tack the slats in place with a single brad at top and bottom, from the back. To protect the lower rail from rot from standing water in the groove, cut blocks, (called fillets), the size of the spaces and glue them in place.

You're now ready to glue and bolt the back to the seat. I used four ¼" threaded bolts with washers to bolt the bottom rail of the back to the back rail of the seat. Hold the bottom edges of each flush, and again use polyurethane glue on this joint.

Next cut the two arms and arm supports from 2x4 material and cut them to shape using the scaled drawings on the next page. You may want to cut the angle on the bottom of the support and on the back end of the arms, then fit them in place and confirm the location and angle of the top end of the supports. Attach the arms to the back with a long deck screw through the back stile. Glue the support to the arm and to the seat with ½" dowels between.

The last step is to put the legs on the table, and to notch and fit the support cleats. Start by cutting the leg pieces to the sizes given in the Schedule of Materials. They are two different lengths to allow the table to sit parallel to the ground, even though the swing itself is angled back. Round over the top end of each leg to allow it to swivel without catching, then drill ¼" clearance holes, ½" down and centered on the legs. Drill clearance holes in the table battens ½" up from the bottom edge, and 1" in from the inside corners. Attach the legs using ¼" x 2½" bolts with two washers on either side of the leg and a nylon-lined nut to hold the legs tight, but not immobile.

Check the spacing between the legs (near the bolts) then cut the leg braces to fit, and screw them in place between the legs.

Now head back to the saw and cut the two table support cleats to fit between the inside stringers. Clamp these in place, center the table in place left to right and mark the location of the legs.

Remove the cleats and cut 7/8" x 1" notches on the leg locations. Then use a handsaw to trim the ends of the legs to form tongues to fit into the mortises you've just created in the cleats. Glue the cleats in place, and once dry, the table will drop into place in the cleats, holding the table steady.

After adding 3/8" x 4" eye bolts to the front and rear of the swing seat, the swing is ready to hang. If you've got a porch, find a sturdy joist and get the lemonade. If you happen to be missing a porch, construct a simple A-frame structure to let you swing in style anywhere in your yard. PW

David Thiel is a Senior Editor for Popular Woodworking.

[Return to Free Projects Plans](#)

© **Popular Woodworking** • [F+W Publications Inc.](#)
[Customer Service FAQs](#)

Popular Woodworking



Articles & Plans

Free Project Plans

Select Articles

Searchable Links

Magazine Extras

Books

Bookstore

Woodworker's Book Club

Store & Services

Subscribe

Buy Back Issues

Gift Subscription

Plans For Sale

Article Index

Customer Service FAQs

Subscriber Services

Other

E-mail Newsletter

Free Information

Advertising Info

Contact the Staff

Home



Download a construction drawing

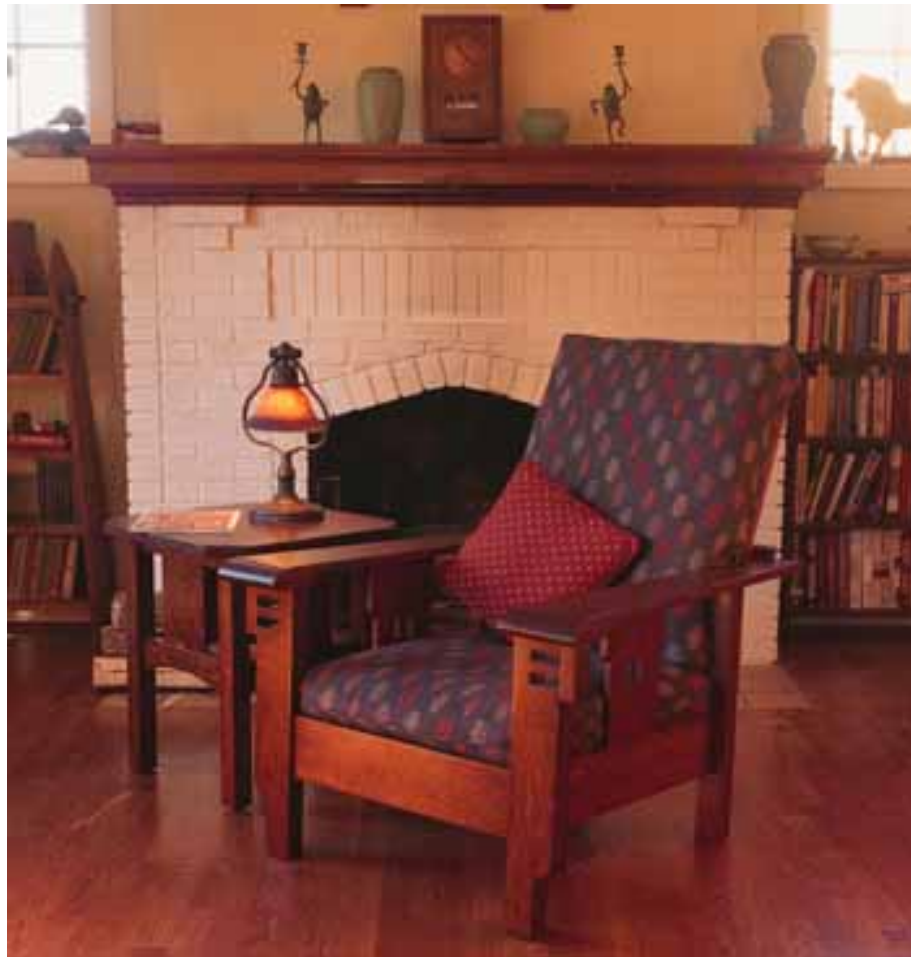

Morris Chair

A faithful reproduction of a classic.

I don't care what they say about dogs, Morris chairs are a man's best friend. The reclining back, wide arms and expansive seat create the perfect place to watch TV, read the Sunday paper or simply contemplate the finer qualities of a well-crafted beer.

For the last 10 years, I've spent every weekend planted in the original version of this chair, which was built by the Shop of the Crafters in Cincinnati, Ohio, during the heyday of the Arts & Crafts movement. The Shop of the Crafters was founded by German-American businessman Oscar Onken (1858-1948), who ran a successful framing company until he entered the furniture business in 1902, according to Kenneth R. Trapp's history of the company.

Unlike many furniture-makers of the day, Onken didn't want to merely copy the Stickleys of the world. Onken produced an unusual line of Arts & Crafts furniture that was influenced more by German and Hungarian designs than the straight-lined Stickley pieces of the day. In all honesty, a few of Onken's pieces were kind of ugly. Most, however, had a refinement and lightness that rivaled some of the best work of the day.

This Morris chair is an almost exact replica of the one produced by Onken and his company. It differs in only two ways. One, the original chair was constructed using dowels at the major joints. After almost 100 years of use, the front and back rail came loose. This chair is built using



1 Make the mortises in the legs before you shape the curve near the bottom or make cutouts on the top.



2 When pattern-routing the curve on the legs, make sure you have the work firmly clamped in place. I have the pattern and leg wedged between two pieces of oak (the pattern is on the underside of the leg). Then the leg itself is clamped to the table. You also could perform this operation on a router table with a starting pin for pattern-routing.

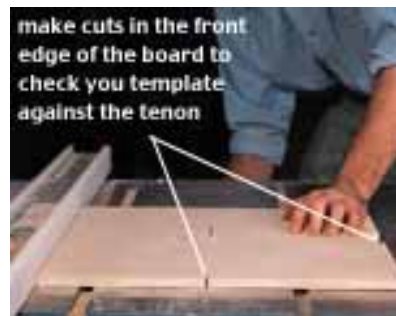

3 To make a template for the mortises in the arms and the cutouts on the side slats, position your plywood over your table saw and raise the blade into the ply. Move the fence over and repeat. Then turn the pattern 90 degrees and repeat for the other edges of the pattern. Note that I made cuts in the front of the pattern to help me size the pattern to the tenons.

pegged mortise-and-tenon joints. Second, I made one change to the chair frame so that furniture historians of the future will know instantly that this not an original piece. I did this to prevent people from passing off these reproductions as originals.

Though this project might look daunting to you, it can be completed by beginners who have just a few projects under their belt. There are only a few principles to learn here: mortising, tenoning and routing with a plywood template. Plus, I'll share with you exactly how I achieved this finish, which has been something we've been working at for several years.

How to Save Money on Lumber

Begin by choosing the right quartersawn white oak for this project. It requires about 10 board feet of 8/4 and 30 board feet of 4/4 lumber. Quartered white oak can be expensive, from \$6 to \$12 a board foot. If you live in the Midwest, or will pass near east-central Indiana on your vacation, I recommend you check out Frank Miller Lumber Co. in Union City, Ind. (765-964-7705). The company is a huge supplier of quartersawn oak. As a result, prices are reasonable, about \$4 to \$6 a board foot. Once you buy your lumber, save the pieces with the most ray flake for the arms, legs, front and sides. To save money, use flat-sawn oak for the seat and the adjustable back.

Mortises: Machine or No Machine?

First cut all your pieces to size according to the Schedule of Materials and begin laying out the locations of your mortises. The rule



4 Be sure to make a full-size mock-up of the legs and sides to determine the angle you need to cut on the bottom of the legs.



5 When you determine that angle, use a grease pencil or magic marker to paint the bottom of the legs. I cut the back and front legs simultaneously. Slowly inch your legs in after each cut until the color is all gone.



6 Peg the tenons that join the front rail to the front legs and the back rail to the back legs. If you've ever pegged tenons before, you know that dowels can be wildly different sizes than they're supposed to be. Here's a trick. If your dowel is a bit undersized, glue it in place and cut it nearly flush to the surface. Then put several drops of thinned glue on the end grain of the dowel. It wicks in the glue, expands and glues up tight. When the glue is dry, cut the dowel flush.

of thumb is that your mortises should be one half the thickness of your tenon's stock. When your stock is 3/4" thick, your mortises and tenons should be 3/8" thick. That means the tenons for the beefy back rail should be thicker (7/16") and those for the side slats should be thinner (1/4").



Also remember that except for the tenons on the legs and slats, all the tenons are 3/4" long. To ensure your tenons don't bottom out in your mortises, it's always a good idea to make your mortises about 1/16" deeper than your tenons are long.

7 Be sure to make a test arm before you go mortising the real thing. You'll be glad you did.

After you mark the locations of all the mortises, it's time cut them. There are 38 mortises in this project. To download a drawing of the back and seat for laying out the mortises, click [HERE](#). You'd be nuts to do these all by hand. Use this project as an excuse to purchase a hollow chisel mortising machine (about \$250) or a mortising attachment for your drill press (about \$70). If you can't swing the cash, I'd make plywood templates and cut the mortises with a router and a pattern bit. Making plywood templates is something covered later in the story.

One more thing: don't cut the mortises in the arms or the arm buildups until the chair frame is assembled. You'll cut these with a router and a pattern bit after the chair frame is assembled.

Tenons With a Dado Stack

Once you get your mortises cut, make tenons that fit snugly into the mortises. You can use a tenoning jig or the fence on your table saw, or you can use a router. I prefer to use a dado stack and my miter gauge.

While your dado stack is in your saw, cut the groove in the back piece that holds the seat frame. See the drawing for the location of this groove.

Once you cut your tenons, prepare to assemble the drop-in seat and the adjustable back. To save yourself some grief, sand the edges of the rails that you won't be able to get to after the frames are assembled. Now put glue in all the mortises and clamp up the frames. Set them aside to dry.

Curves and Cutouts

What makes this Morris chair stand out are the curves and cutouts on the legs, arms and slats. Each curve and cutout needs a slightly different strategy.

The large curves on the legs and the small curves on the side slats were cut using a plywood template and a pattern-cutting bit in a router. I made the patterns from 1/2"-thick Baltic birch plywood. Use the drawings to make your own plywood template using a scroll saw, band saw or coping saw. Smooth all your cuts with sandpaper, then try shaping a couple scraps with your template to make sure your pattern produces the right shape. When satisfied, cut the curves to rough shape on your band saw (about 1/16" shy of your finished line) and clean up the cut with a router and pattern bit. Finish shaping the legs with a chisel.

To produce the large cutouts on the front legs, do what Oscar Onken did: cheat a bit. Make the "cutouts" using a dado stack on your table saw, with the legs on edge. Then glue the applied sides to the legs to cover the open end of the cuts. Instant cutout. While you're at it, cut out the

notches on the arm pieces for the rod that adjusts the back.

To complete the legs, you need to cut the bottom of all four legs at a 2-degree angle so the chair sits flat on the floor. I recommend you make a full-sized mock up (see the photo above) so you can get the angle exactly right. Cut the angle on a chop saw.

Assembly

Now you're almost ready to assemble the chair frame. You'll need to first miter the tenons slightly where they meet to fit in the mortises using your table saw. Now finish sand everything. I went to 150 grit using my random-orbit sander and hand sanded the whole piece with 180 grit. Yes, it makes a noticeable difference.

Now glue the front rail between the front legs and the back rail between the back legs. Clamp and allow your glue to dry. Use 1/4" dowels to pin the tenons from the inside of the chair. This strengthens the weakest point of this chair. It's at this joint where the original chair came loose.

Glue the side rails between the front and back legs and you can see your chair take shape.

Learn to Make Square Templates

Now you need to work on the arms. First glue the arm buildup pieces to the front of the arms. Then get ready to cut the mortises on the arms that will hold the tenons on the legs and side slats. A word of advice here. Mock up an arm out of scrap wood and practice on it first.

To make plywood templates for the

mortises, you need to make a square hole in the middle of a piece of ply. The best way to do this is by making plunge cuts into your plywood on your table saw. Refer to the photo earlier in the story to see how to do this.

Now cut your mortises. I used a template bit with cutters on the bottom and a guide bearing on top. If you don't have a bit with cutters on the bottom, you can still plunge with a straight bit. Just plunge slowly and wiggle the router a bit as you go. Cut the mortises in two passes.

After you're sure the arms fit on the legs, cut the curve on the front of the arm. Attach the full-size pattern to your arm and cut the shape on a band saw. Clean up the cuts with a stationary belt sander. Now taper the arms with your band saw and clean up the cut with your jointer. Glue the arms and slats in place.

Now shape the back rod that adjusts the seat back angle. Bevel one edge of the rod on your jointer and cut notches on the ends so the rod fits between the arms. Attach the back to the seat frame with a piano hinge. Screw the cleats to the front and back of the frame in the locations shown in the diagram; slip the seat in place.

Finishing

This takes some effort, but it is well worth it. The first step is to dye the chair with an alcohol-based aniline dye that's reddish. See the supplies list for ordering information. Then apply one coat of boiled linseed oil to the chair. You can get this at any home center store. Wipe off the excess and let it dry overnight. The linseed oil helps seal the wood before your final coloring step and

helps bring out the ray flake.

Now wipe on a thin coat of Lilly's warm brown glaze. We live and die by this stuff when finishing Arts & Crafts furniture. We're not aware of a catalog that sells it, but you can visit Lilly's website (at the address in the supplies box) to find a paint store that carries this glaze. Wipe the glaze until you achieve an even tone. Allow it to dry overnight. Finally, apply three coats of a clear finish -- whatever you're comfortable with. **PW**

Chris Schwarz is a Senior Editor at Popular Woodworking.

[Return to Free Projects Plans](#)

© **Popular Woodworking** • [F+W Publications Inc.](#)
[Customer Service FAQs](#)

Popular Woodworking



Articles & Plans

[Free Project Plans](#)

[Select Articles](#)

[Searchable Links](#)

[Magazine Extras](#)

Books

[Bookstore](#)

[Woodworker's Book Club](#)

Store & Services

[Subscribe](#)

[Buy Back Issues](#)

[Gift Subscription](#)

[Plans For Sale](#)

[Article Index](#)

[Customer Service FAQs](#)

[Subscriber Services](#)

Other

[E-mail Newsletter](#)

[Free Information](#)

[Advertising Info](#)

[Contact the Staff](#)

[Home](#)



[Download a construction drawing](#)



Tansu Chest

The grain pattern of hard maple reminds me of the ink landscapes drawn by Chinese and Japanese artists beginning in A.D. 700. Each painting, with its jagged mountains and forbidding peaks, was supposed to represent a little story. The viewer followed the people in the painting as they journeyed on a path through the painting. So when I decided to build a step tansu, the obvious choice was maple, despite the fact that these chests were traditionally built from Japanese cypress, cedar or elm.

"Tansu" means chest, and the high period of this type of furniture was between 1657 to 1923. The traditional Japanese household would store clothing, valuables and household items in its tansu.

Construction of this chest is simple. You'll need a sheet and a half of 3/4" maple plywood, one board of 1"-thick maple that's about 8' long and 8" wide and some 1/2" and 1/4" plywood scraps for the drawers. The carcasses of the upper and lower cabinets are built the same way. First cut all your pieces to size and iron on veneer edge tape to cover all the exposed plywood edges.

Now cut the grooves and rabbets on the cabinet stiles. The side panels are glued into 1/2"-deep x 3/4"-wide grooves milled 1/4" in from the edge of the cabinet stiles. The back panel is nailed and glued into a 1/2"-deep x 3/4"-wide rabbet on the inside of the stiles. Screw each assembly to its bottom board. Glue and nail the partitions in place.

Lower Cabinet Doors

Build the two sliding doors using stub tenons that rest in 1/4"-wide by 1/2"-deep grooves. The only

exception to this is the grooves in the thin rails, which should be 1/4" wide and 1/4" deep. Also, the interior stiles are merely applied to the doors after construction; they are not structural. After dry-assembling your doors, glue up and clamp them up.

When dry, glue the interior stiles in place and cut a 1/4"-wide by 1/2"-deep groove on the top and bottom of each door that will allow the door to slide on the runners. Then cut the four runners; make sure they slide smoothly in the doors' grooves. Attach the runners to the top and bottom of the lower cabinet using brads and glue.

I spaced my runners so that the front door is flush to the front edge of the cabinet stiles. Then I left a 1/16" gap between the two doors. Fit the doors to the opening in the chest. Now screw the top to the carcass through cleats that are screwed to the sides and partition of the case.

Upper Cabinet Drawers

Here's how I built my drawers. Cut 1/2" x 3/8" rabbets on the ends of the drawer fronts. Then cut 1/2" x 1/4" rabbets on the back edge of the sides to hold the back piece. Then cut a 1/4" x 1/4" groove to hold the drawer bottom on the sides, back and front that's 1/4" up from the bottom edge. Glue and nail the sides to the drawer front. Slip the bottom in place. Glue and nail the back to the sides.

How you hang the drawers is up to you. I cut 1/4"-deep x 5/8"-wide stopped dados that were centered on each side of the drawer. Then I nailed drawer runners to the carcass's partitions and drawer

runners with plywood build-up strips to the sides. When the drawers move smoothly, nail the top to the case. Putty any nail holes. Apply three coats of a clear finish

You might have noticed from the photo that I made the grain direction of the drawers run vertically instead of horizontally. This is OK for such small drawers, and I did this because each bank of drawers now reminds me of one of those Japanese landscape paintings. **PW**

Chris Schwarz is a senior editor for Popular Woodworking.

[Return to Free Projects Plans](#)

© **Popular Woodworking** • [F+W Publications Inc.](#)
[Customer Service FAQs](#)

Popular Woodworking



Articles & Plans

Free Project Plans

Select Articles

Searchable Links

Magazine Extras

Books

Bookstore

Woodworker's Book Club

Store & Services

Subscribe

Buy Back Issues

Gift Subscription

Plans For Sale

Article Index

Customer Service FAQs

Subscriber Services

Other

E-mail Newsletter

Free Information

Advertising Info

Contact the Staff

Home



Download a construction drawing

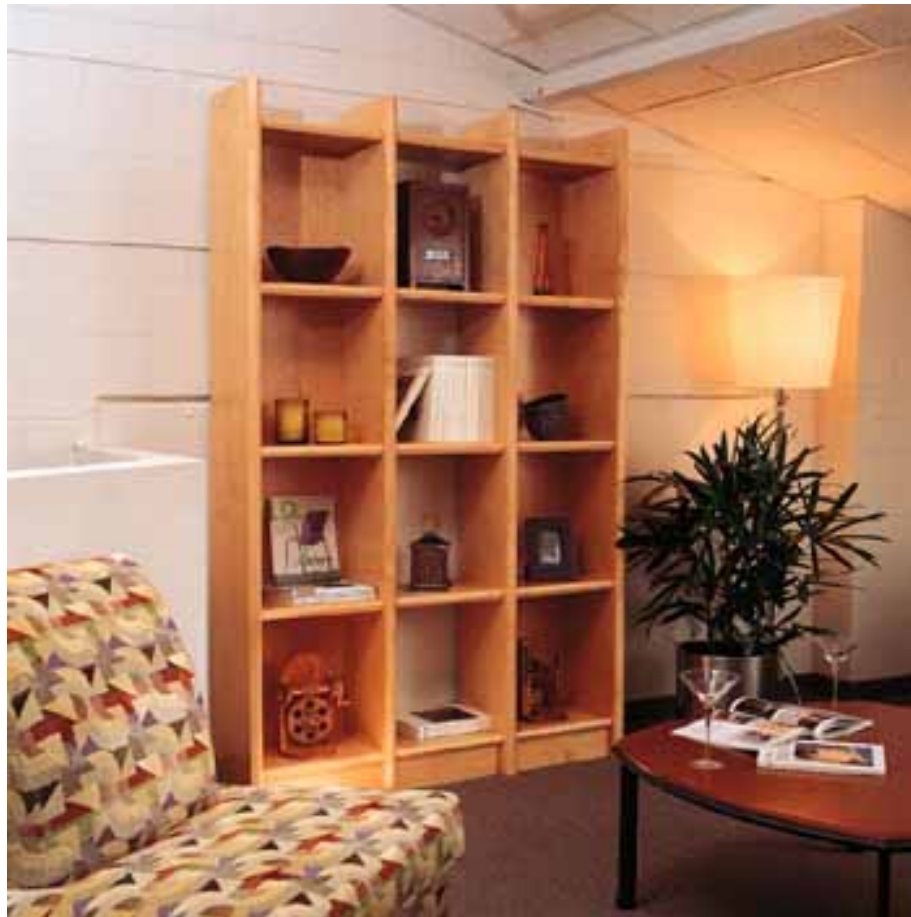

Contemporary Shelves

It's rare that bookshelves look as interesting as the objects you display on them. After all, how much can you decorate the edges of your shelves and sides? This unit is unusual because the shelves and sides are beefier than you would normally see, and the two bevel cuts on the front edges give these shelves nice visual interest. Best of all, perhaps, is that this piece is simple and quick to build.

Dividers and Shelves

Start by cutting out the sides and shelves. The 1-1/2"-thick sides are made by gluing two pieces of 3/4"-thick plywood together. The 1-1/4"-thick shelves are made by gluing 3/4"-thick plywood to a 1/2"-thick piece. Note that the finished sides have a 3/4" x 1/4" rabbet for the back that's formed by gluing a narrower piece to a wider one. The adjustable and fixed shelves in the side openings are all the same width. The center shelves are 1/4" wider to account for the lack of a back.

To cut the sides, crosscut a whole sheet of plywood to the length of the sides first, then rip them to width (11" and 11-1/4"). Cut the sides a little wide (1/16"), initially, to give yourself a little room to saw off a square straight edge. This will give you a clean edge for attaching a piece of maple later. Now nail and glue the dividers together, remembering to offset the back edge for the rabbet. Place your nails so the shelves will hide them.

Here's an easy way to cut the shelves. Rip them to width from a full piece of plywood, then nail and glue up a length of shelving. Then crosscut the shelves to length from the long pieces. You can get five 16"



1 Face-Glue the Parts: Once you've got your parts cut to size, glue and nail them together leaving the rabbet at the back. Set and putty the nails, then rip the dividers to their final width.



2 Profile: The bevels on the edges are basically a "V" shape on the entire edge. See the diagram at right for the details and cutting angles. Clean up your saw marks with a plane.

shelves out of a 96" rip. For even less work, cut the shelves to length after attaching the edging.

Edges and Angles

The edges for the bookshelves are solid maple. Because the thickness of 3/4" and 1/2" plywood is considered "nominal," you will end up with finished thicknesses about 1/16" less. Rip your edging stock a little wide and attach it with biscuits and glue. With a flush-cut bearing bit in a router, trim the edging flush to the sides and shelves, then clean up your work with a plane or scraper.

The last step is to bevel the edging. The photo shows how I did this on the table saw. Remember that the setup must change for the different width pieces.

Making it a Stand-Up Unit

The next step is to mill stopped grooves in the topmost and bottommost shelves to accept the tapered sliding connectors that attach the sides together. The grooves in the ends of the shelves are 3/4" wide by approximately 3/8" deep, and milled with a dado set on the table saw. It helps to make a practice joint because the depth of the groove is critical to a snug fit using this style of connector.

Installing the Shelves

After cutting the slots in the shelves, lay out and mount the small part of the tapered connector to the side. The large connector will mount to the shelf groove with the wide end towards the shelf front. Do a test fit on the shelves. The shelves in the side units should be flush to the rabbet in the back edge of the sides. The center shelves should be flush with the back.

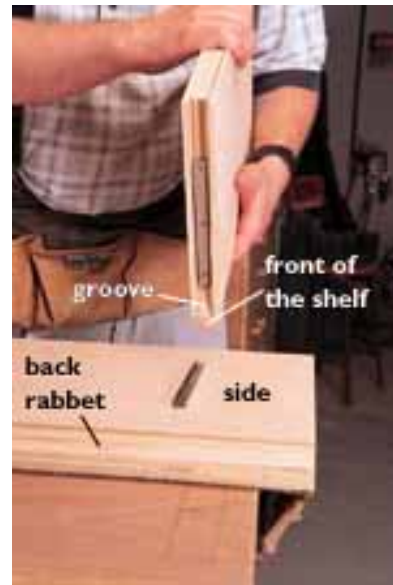

3 Mount Knockdown Hardware: Use a dado stack to cut a 3/4" x 3/8" groove from the joint where the edge attaches to the shelf to the back of the shelf. The knockdown hardware is mounted in about the middle of the shelf. It pulls together pretty tightly, so you might want to sand any bumps or ridges off the ends of the shelves to keep from scratching the sides.

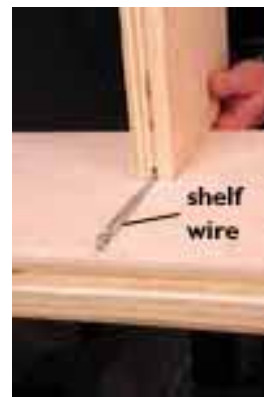

4 Magic Wire: After cutting the 1/8" grooves in the shelf sides, assemble the case. Tap the wire shelf supports in and slide the loose shelves in place.

The next step is to cut the stopped grooves in the rest of the shelves for the hidden wire shelf supports. If your blade is too narrow, take two cuts to get the 1/8" groove necessary to slide the shelf onto the wire supports. Some drill and chisel work will be necessary to lengthen the kerf to accept the entire 9-3/4" length of the shelf wire. This requires drilling and chiselling into the end of the front edge. Lay out and drill the locations for the wire supports in the side and center sections so the shelf heights will match across the bookcase.

Now it's time for all the parts come together. Begin by assembling the two outside units of the bookcase. Tip them onto their backs and attach the aprons to the bottom shelf using cleats and screws. Next attach the side units together forming the center section. The best way to do this is to assemble with the front facing up. Use a handscrew clamp to hold up the sides while you're assembling. The apron on the center bottom can be screwed onto the shelf and braced with corner blocks prior to assembly. Push the lower shelf into place and mark the location of the apron, also called a "kick" or a base. Then remove the shelf and add two stop blocks to the sides to support the center apron from behind.

When you're happy with the fit of the parts, disassemble the bookcase and finish. I applied a coat of light stain to give the maple an aged appearance. (I used about two ounces of linseed oil and colored it with Olympic stains, one-half Early American #41552, and one-half Red Oak #41567. 1/4 teaspoon of each.) Wipe on an even coat of oil. Wipe off the excess and let it dry for 24 hours. The next day, lightly sand the

surfaces and clean them with a tack rag. Finish with two or three coats of a clear finish. **PW**

Jim Stuard is a former associate editor at Popular Woodworking.

[Return to Free Projects Plans](#)

© **Popular Woodworking** • [F+W Publications Inc.](#)
[Customer Service FAQs](#)

Popular Woodworking



Articles & Plans

Free Project Plans

Select Articles

Searchable Links

Magazine Extras

Books

Bookstore

Woodworker's Book Club

Store & Services

Subscribe

Buy Back Issues

Gift Subscription

Plans For Sale

Article Index

Customer Service FAQs

Subscriber Services

Other

E-mail Newsletter

Free Information

Advertising Info

Contact the Staff

Home



Download a construction drawing



Drill Press Table

Turn your drill press table into a woodworking table in a few hours.

Despite the fact that your drill press is designed mostly for poking holes in sheet metal, it has many uses in a woodshop. It's a mortiser, a spindle sander, it bores huge holes, and -- of course -- drills holes at perfect right angles to the table. Because the table on most drill presses is designed for metalworking, it's hardly suited for these tasks. So I built this add-on table with features that will turn your drill press into a far friendlier machine:

First, a fence that slides forwards and backwards as well as left and right on either side of the quill. This last feature also uses the drill press' tilting table feature with the auxiliary table for angled drilling.

Built-in stops (both left and right) that attach to the fence for repetitive procedures such as doweling or chain drilling for mortises.

Hold-downs that can be used on the fence or on the table for any procedure.

The sizes given in the Schedule of Materials are for a 14" drill press, with the center falling 9" from the rear edge of the table, with a 2" notch in the back to straddle the column. Adjust the center location and overall size of the table to match your particular machine.

Start With the Base-ics

The base platform for the table is made from 3/4" plywood, which should be void-free. Again, adjust the size as necessary to fit your drill press. First you need to get the table ready for the T-track, which is what



1 Another view of the drill-press table. Here I'm cutting pocket holes in a table apron.



2 ROUT THE GROOVE The grooves for the T-slot track allow the fence to be used left-to-right and front-to-back on the table to take advantage of the built-in tilting feature of the existing table.



3 RABBET FOR THE INSERT After cutting the hole with a jigsaw, the opening is rabbeted using a bearing-piloted router bit. Then chisel the corners square and fit the replaceable center tightly into the rabbet. Make a couple extras.



4 ROCK SOLID The fence is made of a sturdy, stable hardwood. Cut a groove the length of the top and face of the fence. The grooves support T-slot tracks, which can

holds the fence and hold-downs in place. Start by locating the four recessed holes that allow the T-slot mechanism to slip into the track without disassembling the mechanism. Each hole is 1-1/2" in diameter and 3/8" deep.

Next, locate the grooves in the center of the holes and use a router with a 3/4"-wide straight bit to cut the grooves to a 3/8" depth. The T-slot track should fit into the grooves with the top surface just below that of the plywood table. The grooves should be as parallel as possible to one another to allow smooth movement of the fence.

Replaceable Center

Now cut the hole for the 4" x 4" replaceable insert. First locate and mark the position centered on your table, then mark in from that line by 3/8" to locate your cutting line. Drill clearance holes in two corners of the square, then use a jigsaw to cut out the center piece. Next, determine the thickness of the material you will use for your insert (the 3/8"-thick Baltic Birch we used is actually metric and shy of 3/8") and set a 3/8" piloted rabbeting bit in a router to a height to hold the insert flush to the top surface of the table.

While your jigsaw is still out, locate, mark and cut out the notch in the back of the table. This allows the table to move closer to the drill press' post and tilt without interference.

As a final friendly touch on the table, I used a 3/8" roundover bit in my router to soften all the edges on the table, both top and bottom. You'll get fewer splinters if you do this.

Milling the Fence

be used for stops, hold-downs and other accessories.



5 FENCE BRACES The fence is supported by two simple brackets screwed to the rear of the fence. The location of the triangular braces is important to the track orientation, so follow the diagrams carefully for location.



6 LAYING TRACKS Install the T-slot tracks in the grooves with flat head screws countersunk into the track. The braces are attached to the fence by screwing through the face groove prior to attaching the T-slot track.



7 HOLD IT The hold-downs and stops are made from 3/4" hardwood. To make the guide to hold the stops square to the fence, cut a 1/16" x 1-1/8" rabbet on both sides of the inside face.

The fence is the heart of the table, and the wood should be chosen for durability and straightness. Quartersawn hardwood, carefully surfaced and planed, will do nicely. After cutting the fence to size, use a dado stack to mill two 3/8"-deep by 3/4"-wide grooves in the fence. The first is centered on the top surface of the fence, and as in the grooves in the base platform, a piece of T-slot track should be used to confirm that the groove is deep enough to allow the track to fit just below the surface of the wood. The second groove is then cut centered on the face of the fence. One other bit of table saw work is the 1/8" x 1/4" wide rabbet cut on the inside bottom edge of the fence. This rabbet allows dust and debris to be pushed into the rabbet, so your work will fit against the fence.

One option that I considered was adding an indexing tape measure on the fence. Every time the table is moved the tape would need to be readjusted to zero, and for the infrequent use the tape would see I decided against it. A stick-on tape can easily be added to the fence face if that's more to your personal taste and needs.

Fence Support Braces

Unlike the fence on a router table, the fence on a drill press table won't see a lot of lateral pressure. So the main purpose of the braces is to hold the fence square to the table at the drilling point. In my case I've also given the braces the job of mounting the fence to the table.

Start by cutting the two base plates and the four braces to size. The braces are triangles with the bottom edge 3" long and the adjoining right angle edge 1-7/8" long. The third side is determined by simply

connecting the corners. Locate the braces on the base plates according to the diagrams and pre-drill and countersink 3/16" diameter holes in the base plates to attach the braces to the plates.

To mount the support braces to the fence, again refer to the diagrams to locate the proper spacing on the fence. Then drill and countersink screw holes through the face groove in the fence. Clamp the brace to the fence and screw the brace in place.

With the braces attached to the fence, use the T-slot fastener locations on the diagrams as a starting point for drilling the holes in the base plates, but check the location against your table for the best fit. Two holes are drilled in each plate to allow the fence to be moved to the perpendicular position (either to the right or left of the quill), by simply relocating one of the T-slot fasteners. Check each hole in relationship to that position.

Attaching the Track

Assuming you purchased the 24" lengths of track listed in the Schedule of Materials, you should be able to cut the tracks for the table first, leaving fall off that can be added to the two remaining full length tracks to give you the necessary 30" lengths of track for the fence. When attaching the track, first pilot drill the hole in the center of the track (a groove is provided in the track to simplify that location), then use a countersink to widen the hole to accommodate a #4 x 5/8" flat head screw. Keeping the screws as flush as possible to the inner surface of the track will make the stops and hold-downs move much easier.

Finishing Touches

Stops and hold-downs designed for use in T-tracks make the drill press most useful. The stops are simply square blocks of wood with one side milled to leave an indexing strip that fits into the slot on the T-slot track. By using the saw to cut tall but shallow rabbets on two edges of each block, the stops are completed fairly easily. For safety, run the rabbet on a longer 2-1/2" wide piece of wood, then cut the stops to square afterward. The T-slot fasteners are simply inserted into a 1/4" hole drilled in the center of each stop block.

The hold-downs are simply blocks of wood with DeStaCo clamps mounted to the top. Each block is drilled for two T-slot fasteners, one on either end. Then the clamp is screwed to the top surface of the block. While the DeStaCos are good for this application, they aren't as versatile as I wanted. I replaced the threaded-rod plunger with longer all-thread (1/4" x 36) to provide maximum benefit from the clamps. The rubber tip of the plunger is important to the function of the clamp, and if you can manage to reuse the existing tip it's very helpful. If not, I found rubber stoppers in a variety of sizes in the local Sears hardware store. After carefully drilling a 1/4"-diameter hole two-thirds of the way into the stopper I was able to screw it onto the rod with little difficulty.

Attaching and Personalizing

The table should attach easily to your existing drill press table using four lag bolts countersunk flush into the surface of the auxiliary table. Once attached you should find that the auxiliary table overhangs the metal table quite a bit. One personalized touch I want to suggest is adding small drawers to the

underside of the table to store bits, wrenches and chuck keys. **PW**

David Thiel is a senior editor for Popular Woodworking.

[Return to Free Projects Plans](#)

© **Popular Woodworking** • [F+W Publications Inc.](#)
[Customer Service FAQs](#)

Popular Woodworking



Articles & Plans

[Free Project Plans](#)

[Select Articles](#)

[Searchable Links](#)

[Magazine Extras](#)

Books

[Bookstore](#)

[Woodworker's Book Club](#)

Store & Services

[Subscribe](#)

[Buy Back Issues](#)

[Gift Subscription](#)

[Plans For Sale](#)

[Article Index](#)

[Customer Service FAQs](#)

[Subscriber Services](#)

Other

[E-mail Newsletter](#)

[Free Information](#)

[Advertising Info](#)

[Contact the Staff](#)

[Home](#)



Download a construction drawing



Bungalow Mailbox

This project was by request. As I live in the 'burbs and have to walk to the curb to pick up my bills, a mailbox mounted next to my front door would be purely decorative. But a friend lucky enough to have postal delivery right to his door asked if I could come up with an appropriate design for his Arts & Crafts-style bungalow home.

After a little research I settled on a design reminiscent of the work of Charles Rennie Mackintosh. Arguably Scotland's greatest 20th century architect and designer, Mackintosh inspired much of the European Arts & Crafts movement during the early 1900s. A stylized flower motif is found on many of his pieces.

1 Mostly Glue • The joinery for the box is primarily glue and butt joints, utilizing the long grain-to-long grain orientation of the sides, back and front. The bottom, however sits in a tongue-and-groove joint between the front and back pieces to allow the wood to move.

After cutting the pieces according to the Schedule of Materials, cut a 1/4" x 1/8" rabbet on the underside of the two long edges of the bottom. This will leave a 1/8" x 1/8" tongue on the front and back of the bottom (photo one, left). Then cut the dadoes on the inside bottom of the front and back pieces by setting the rip fence for 1/2" and the blade height to 3/16" (photo one, right).

2 Adding the Angles • Now cut the sides of the mailbox on an angle so you can attach the mailbox to your house without cramming a tool inside the box. The sides slope at a 25-degree angle with the front edge measuring 9" tall and the back edge 11" tall.

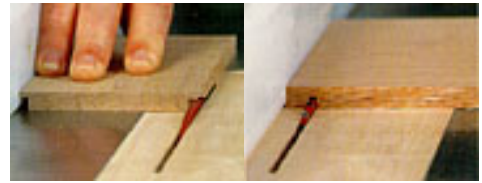

1 BOTTOM JOINERY • The bottom fits into the front and back pieces using a tongue and groove method. The sides are not attached to the bottom, and in fact the bottom is cut to allow a 1/16" gap on either side. Should water happen to get into the mailbox, these gaps will allow it to escape rather than pool up in the bottom.



2 TOP CHAMFER • The top is chamfer cut on three edges, and angle cut on the back edge. By moving my rip fence to the left of the blade, my right-tilt saw is able to make the cuts safely, allowing the waste to fall away from the blade.

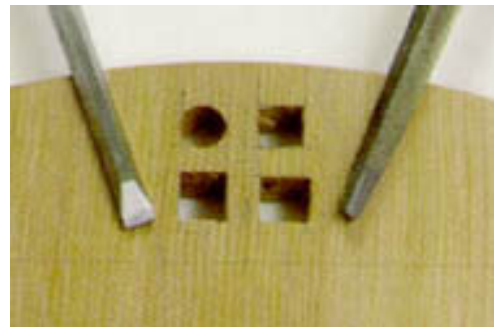

3 FOUR-SQUARE • After drilling the holes, use a 1/8" chisel and a triangular file to clean up the hole. The top left hole is shown after drilling, while the two lower holes have been completed.

Now cut the chamfer on the underside of the lid. The front and two sides are chamfered at a 45-degree angle on the table saw, leaving a 3/16" flat edge to the top of the lid. The back edge of the lid is cut at a 25-degree angle to mate with the box's back.

3 Detailing the Back • To add another Mackintosh feature, I cut a four-square pattern centered in the top of the curved back.

First mark the location of the four-square pattern as shown on the diagram. Use a 3/8" drill bit to remove most of the waste from the squares. Then use a chisel and a triangular file to clean up the cuts. To make the curve, draw a 6" radius along the top edge of the back and cut to the mark on the band saw.

After sanding, you're ready to glue up the box. The front is set back 1/4" on the sides, while the back is flush to the back edge. The bottom is left loose in the assembly.

Now cut out the applied detail from 1/8" stock on the scroll saw.

Finishing Touches

Before gluing the flower to the box, stain the box a rustic-looking gray-brown by applying a black aniline dye wash. The wash was made by diluting the dye eight-to-one with denatured alcohol. I then colored the flower and stem pieces with undiluted aniline dye. Attach the flower pieces using cyanoacrylate glue. To finish, use a coat of spar urethane for outdoor protection.

The final tasks are installing a small jewelry box continuous hinge for the lid and the copper magazine hooks. I made the hooks from a couple pieces of 3/4" copper tubing. Flatten the piece with a dead blow hammer, then use a ball-peen hammer to add a dimpled, hand-hammered appearance. I then

"antiqued" the copper using a product called Patina Green from a company called Modern Options (415-252-5580). The product quickly adds a nice green patina.

Now screw the two hooks to the back, and the mailbox is ready to hang. **PW**

David Thiel is a senior editor at Popular Woodworking magazine.

[Return to Free Projects Plans](#)

© **Popular Woodworking** • [F+W Publications Inc.](#)
[Customer Service FAQs](#)

SUPPLIES

- 4 - Locking swivel casters with 2" - diameter wheels
- 3 - Drawer pulls
- 3 - 20" drawer slides, contact Accuride (562-903-0202 or accuride.com) for a distributor near you

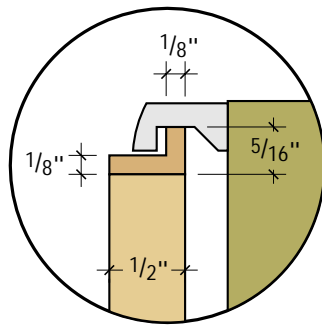

Hanger rail section

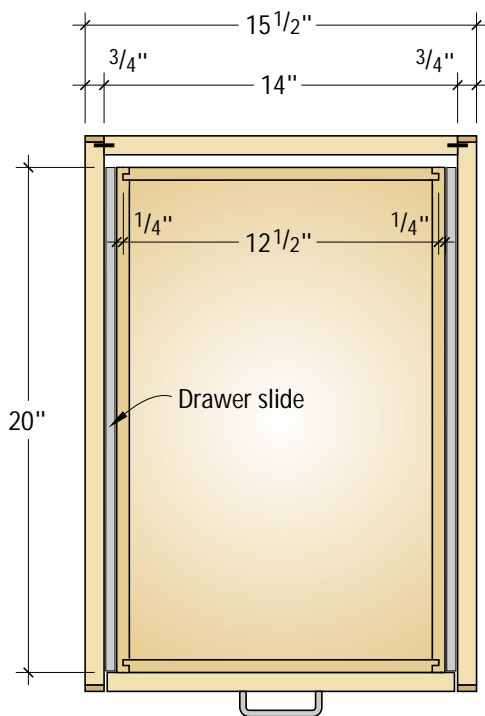

Horizontal section

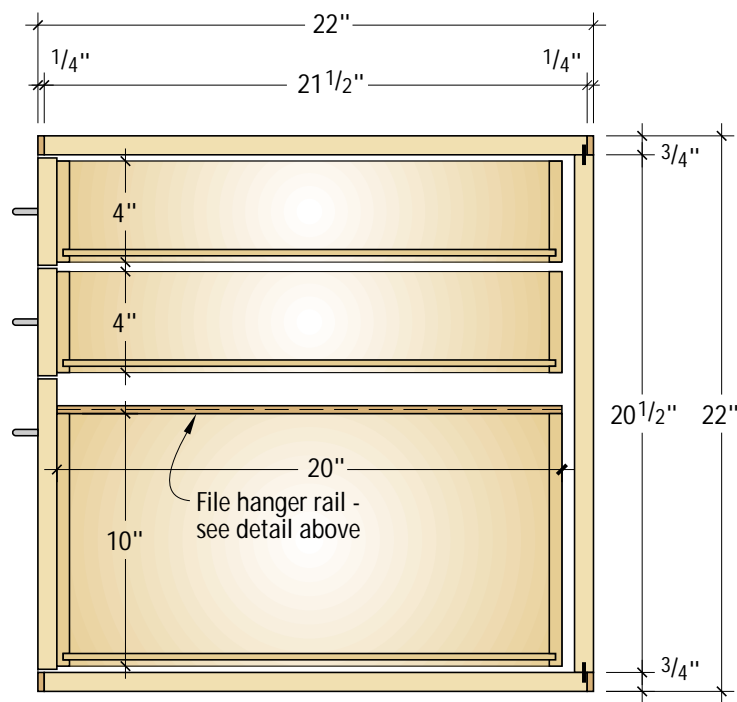

Profile section

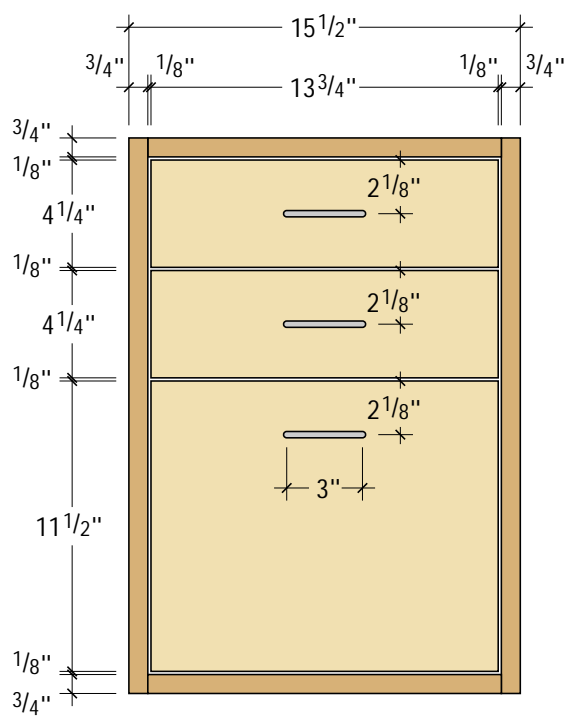

Elevation

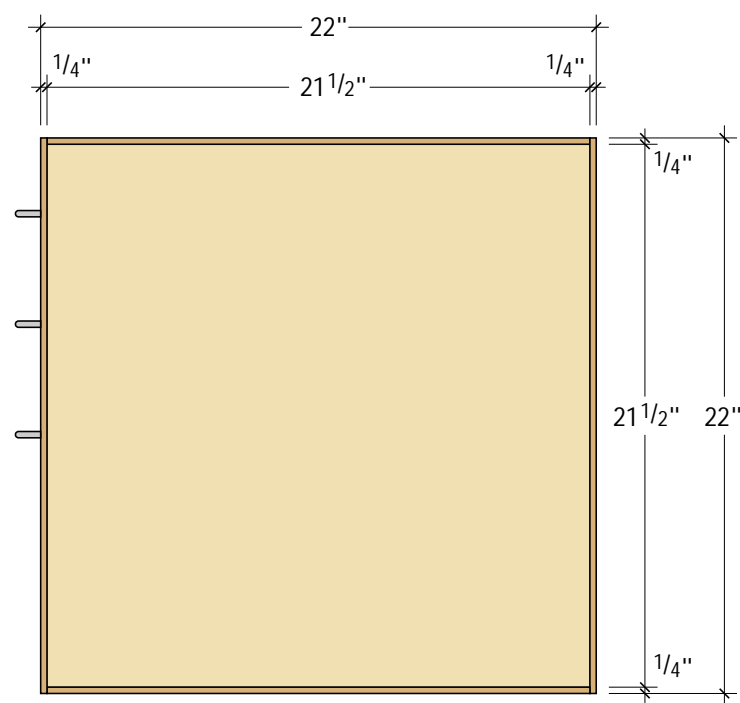

Profile

MOBILE FILE CABINET

NO.	ITEM	DIMENSIONS (INCHES)			MATERIAL
		T	W	L	
CABINET*					
2	Sides	3/4	21 1/2	21 1/2	Birch ply
2	Top & bottom	3/4	21 1/2	14	Birch ply
1	Back	3/4	14	20 1/2	Birch ply
12	Edge trim	3/4	1/4	24	Cherry
DRAWERS					
3	Bottoms	1/4	12 1/2	19 1/2	Birch ply
4	Upper sides	1/2	4	20	Baltic birch
4	Upper frts/bks	1/2	4	12 1/2	Baltic birch
2	Lower sides	1/2	10	20	Baltic birch
2	Lower frt & bk	1/2	10	12 1/2	Baltic birch
2	Upper false frts	3/4	4 1/4	13 3/4	Birch ply
1	Lower false frt	3/4	11 1/2	13 3/4	Birch ply
2	Hanging rails	5/16	1/2	20	Cherry

* Measurements of plywood parts do not include cherry edge banding.

SOURCES

Lee Valley Tools
800-871-8158
leevalley.com

Brass piano hinge,
12mm x 800mm,

Brass escutcheon pins,
flat head

Chicago bolts, brass,
30 - 36mm, 4 pack

Craft Supplies USA
800-551-8876
woodturnerscatalog.com

Masters Magic Lacquer
Sanding Sealer, aerosol can

Masters Magic Satin Spray
Lacquer, aerosol can

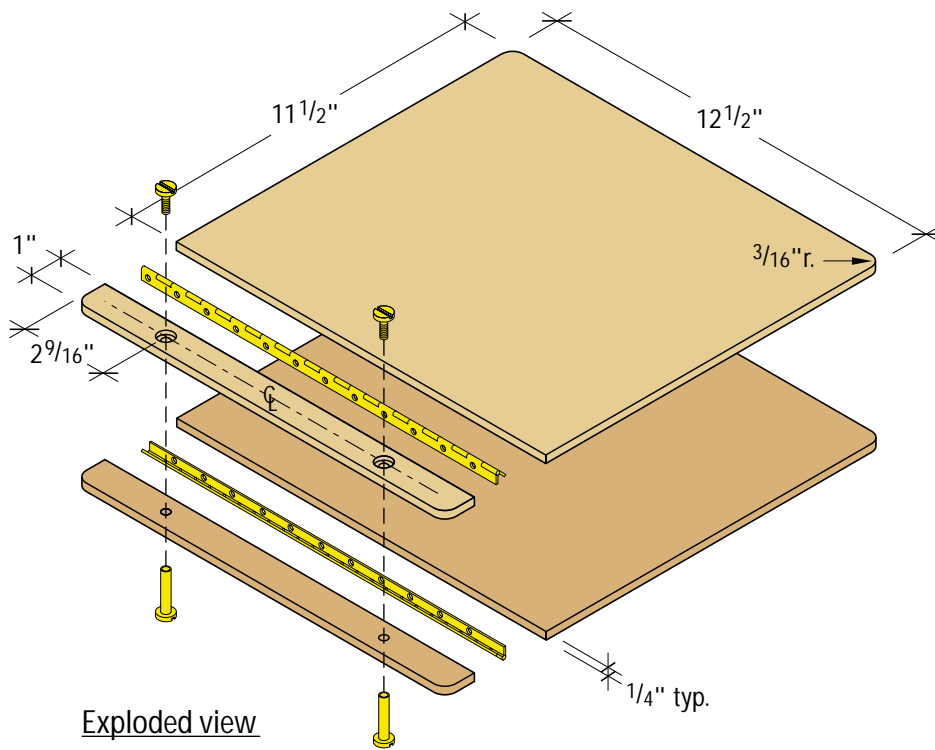

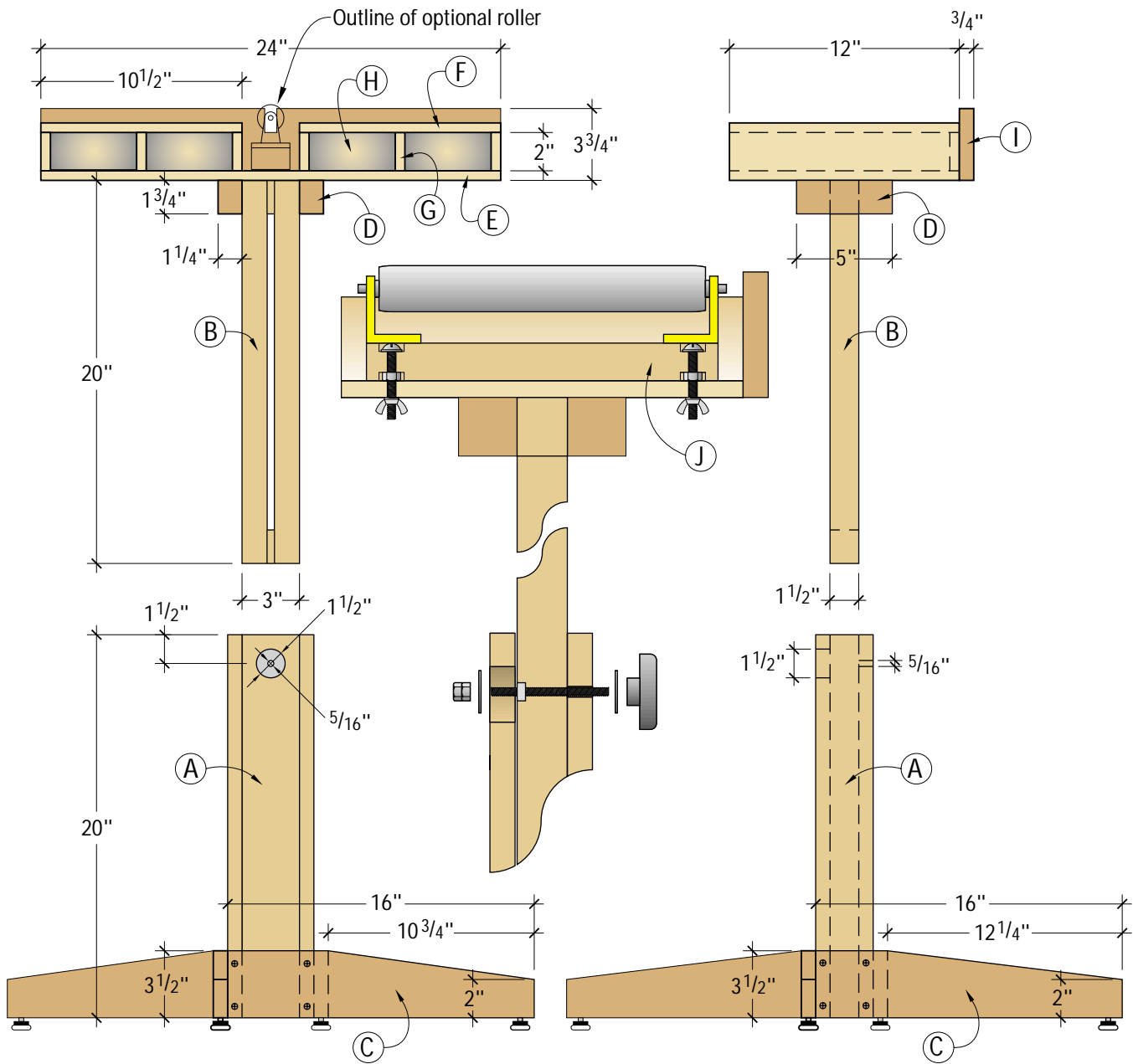

CUT-OFF STAND

NO.	LET.	ITEM	DIMENSIONS (INCHES)			MATERIAL	HARDWARE			
			T	W	L		NO.	ITEM		
<input type="checkbox"/>	4	A	Column sides	3/4	3	20	Hardwood	<input type="checkbox"/>	1	Star knob, (item# 862214)*, \$1.49
<input type="checkbox"/>	1	B	Post	1 1/2	3	20	Hardwood	<input type="checkbox"/>	1	Threaded rod, 1/4"-20 x 3 1/2"
<input type="checkbox"/>	4	C	Feet	3/4	3 1/2	16	Hardwood	<input type="checkbox"/>	4	1/4"- 20 hexagonal nuts
<input type="checkbox"/>	2	D	Mounting blocks	1 1/4	1 3/4	5	Hardwood	<input type="checkbox"/>	1	1/4"- 20 square nut
<input type="checkbox"/>	1	E	Bottom	1/2	12	24	Plywood	<input type="checkbox"/>	2	1/16" x 1 1/2" fender washers
<input type="checkbox"/>	2	F	Tops	1/2	12	10 1/2	Plywood	<input type="checkbox"/>	2	1/4"- 20 x 1 3/4" machine bolts
<input type="checkbox"/>	6	G	Dividers	1/2	2	12	Plywood	<input type="checkbox"/>	2	1/4"- 20 wing nuts
<input type="checkbox"/>	4	H	Backs	1/2	2	4 1/2	Plywood	<input type="checkbox"/>	2	1/4" lock washers
<input type="checkbox"/>	1	I	Fence	3/4	3 3/4	24	Hardwood	<input type="checkbox"/>	1	10" roller (item #921635)*, \$7.69
<input type="checkbox"/>	1	J	Roller block	1 1/8	2	9 1/2	Hardwood	<input type="checkbox"/>	1	Bracket set (item #95-505)*, \$3.29



You might prefer a tapered-leg taboret with wedged tenons...



...or a globe stand in the style of Frank Lloyd Wright...

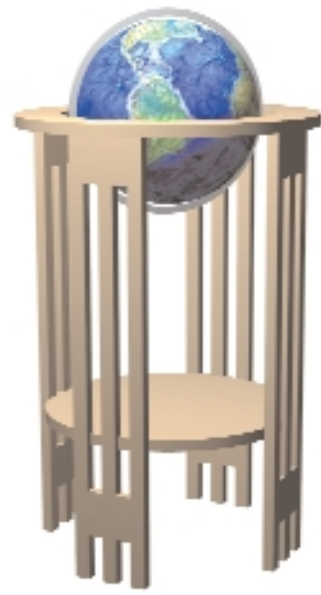

...or even in the style of a Gustav Stickley end table.

ARTS & CRAFTS GLOBE STAND

NO.	ITEM	DIMENSIONS (INCHES)			MATERIAL
		T	W	L	
4	Top pieces	3/4	5 5/16	14 1/2	Cherry
2	Table pieces	3/4	5	10	Cherry
4	Legs	1 1/2	1 1/2	29 3/4	Cherry
2	Stretchers	3/4	2 1/2	18	Cherry
4	Corbels	3/4	7/8	9	Cherry

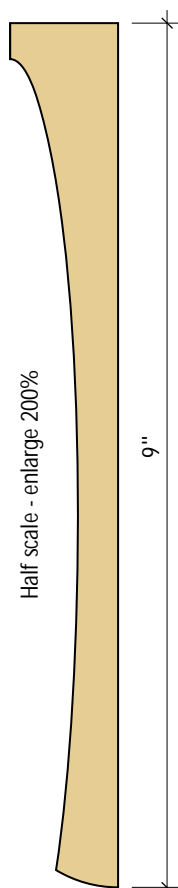
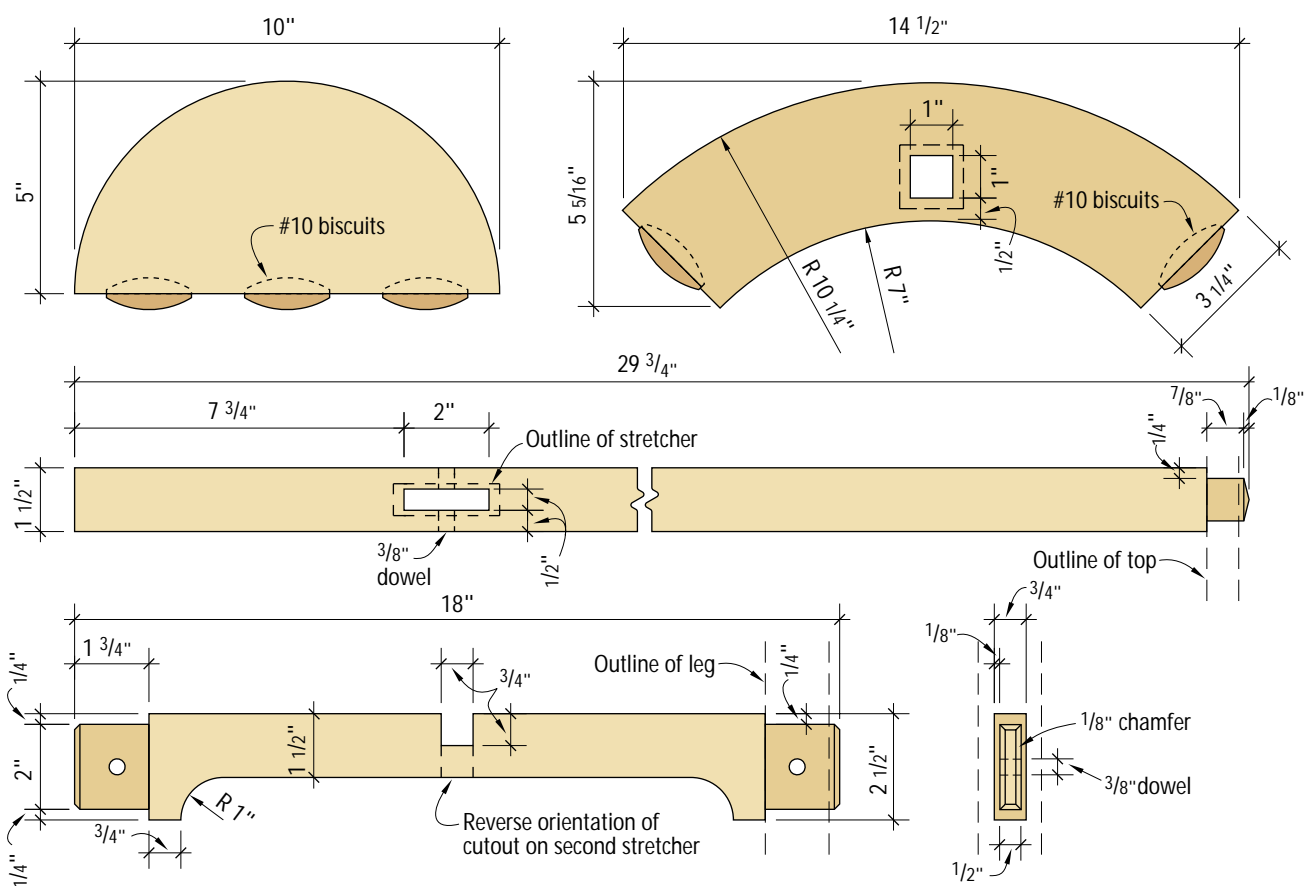

SUPPLIES

Popular Woodworking readers can order this 12" antique globe for \$70 (a 10 percent discount) plus shipping (and sales tax if you live in Ohio).

Contact:

The Map Store
5821 Karric Square Drive
Dublin, OH 43017
614-792-6277

SHAKER STORAGE CABINET

NO.	LET.	ITEM	DIMENSIONS (INCHES)			MATERIAL
			T	W	L	
Face Frame						
2	A	Stiles	3/4	2 1/2	51 1/4	Poplar
1	B	Top rail*	3/4	2	45	Poplar
1	C	Bottom rail*	3/4	5 1/2	45	Poplar
Doors						
4	D	Stiles	3/4	2 1/2	43 3/4	Poplar
6	E	Rails*	3/4	2 1/2	18 1/2	Poplar
4	F	Panels	5/8	17	18 5/8	Poplar
Carcase						
1	G	Top	3/4	19	50	Maple
2	H	Sides	3/4	17 1/4	51 1/4	Poplar
1	I	Bottom	3/4	16 3/4	47	Poplar
2	J	Dividers	3/4	16 1/4	45 1/2	Poplar
1	K	Nailing strip	3/4	1 1/2	46 1/2	Poplar
1	L	Blocking 1	3/4	2 1/4	45 1/2	Poplar
1	M	Blocking 2	1/2	1 3/4	45 1/2	Poplar
5	N	Adj. shelves	3/4	16 1/4	22 5/8	Poplar
10	O	Masonite shelves	1/4	16 1/4	20 1/4	Masonite
1	P	Back	1/2	47	51 1/4	Ply

*= 1" tenon on both ends

SUPPLIES

Woodworker's Supply
800-645-9292

Amerock non-mortising hinges,
#891-749, \$2.95 each

Horton Brasses
800-754-9127

Maple knobs, #WK-3, 1 1/2" diameter,
call for pricing

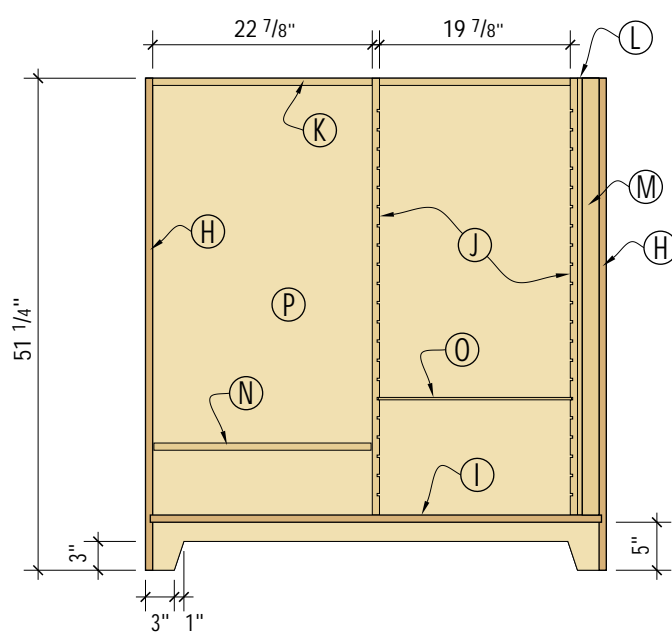
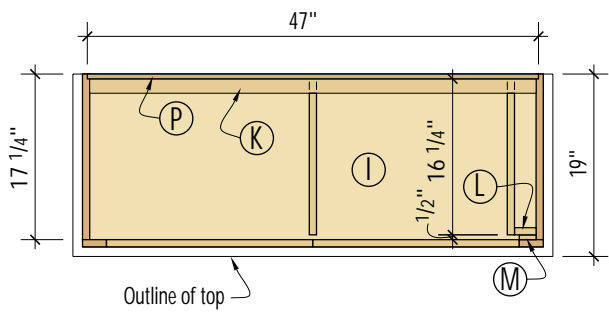
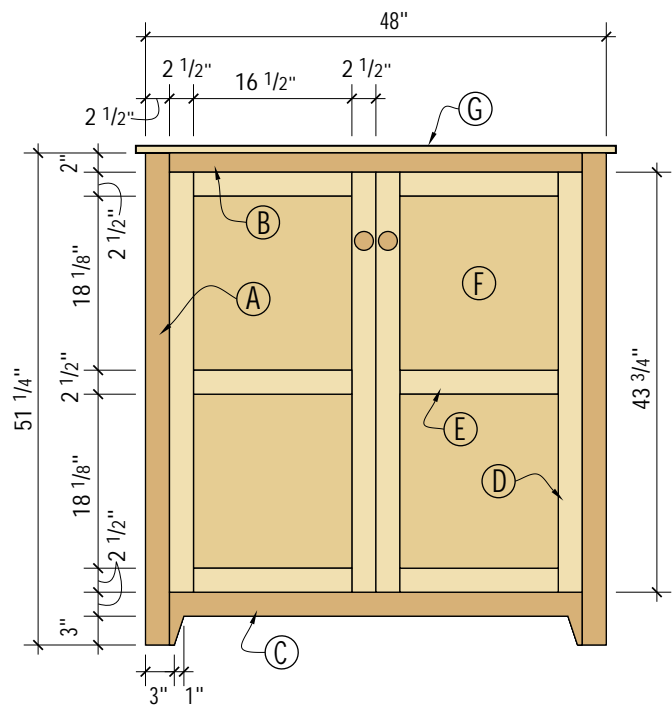
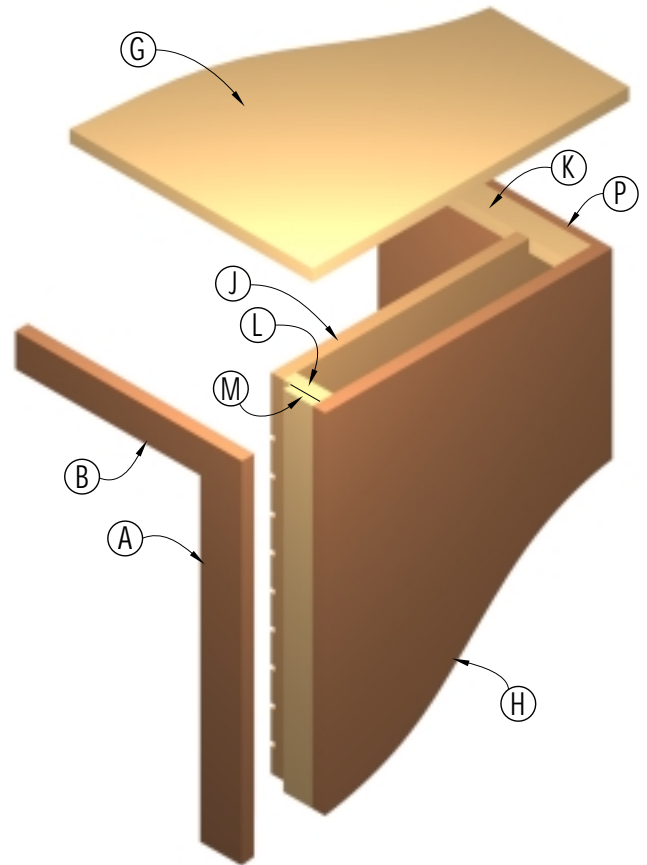

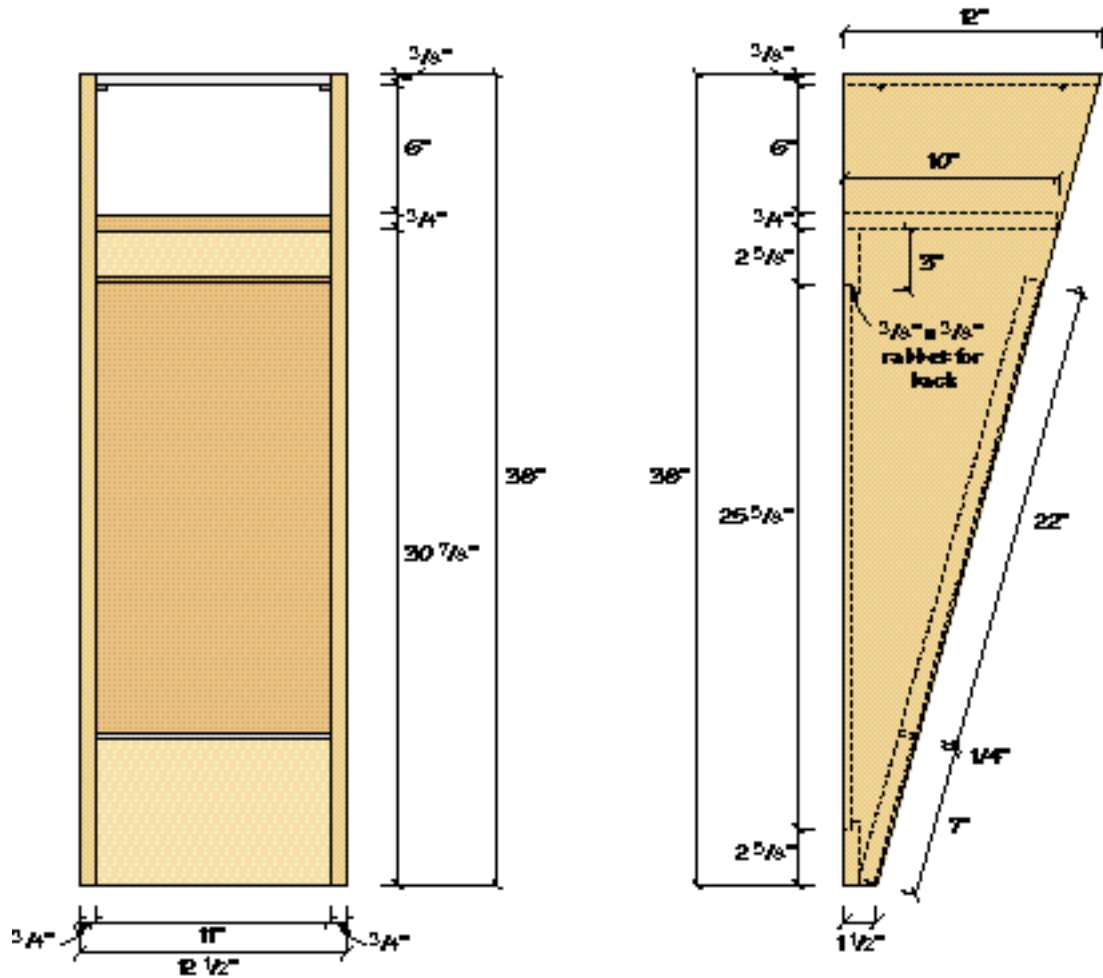

European Telephone Console

No.	Item	Dimensions T W L	Material
2	Sides	3/4" x 12" x 38"	Cherry ply
1	Shelf	3/4" x 10" x 11"	Cherry ply
2	Cleats	3/4" x 3" x 11"	Cherry ply
1	Kick	3/4" x 11" x 7"	Cherry ply
1	Door	3/4" x 11" x 22"	Cherry ply
1	Back	1/4" x 11 3/4" x 25 5/8"	Cherry ply
1	Top	3/8" x 11" x 12"	Acrylic

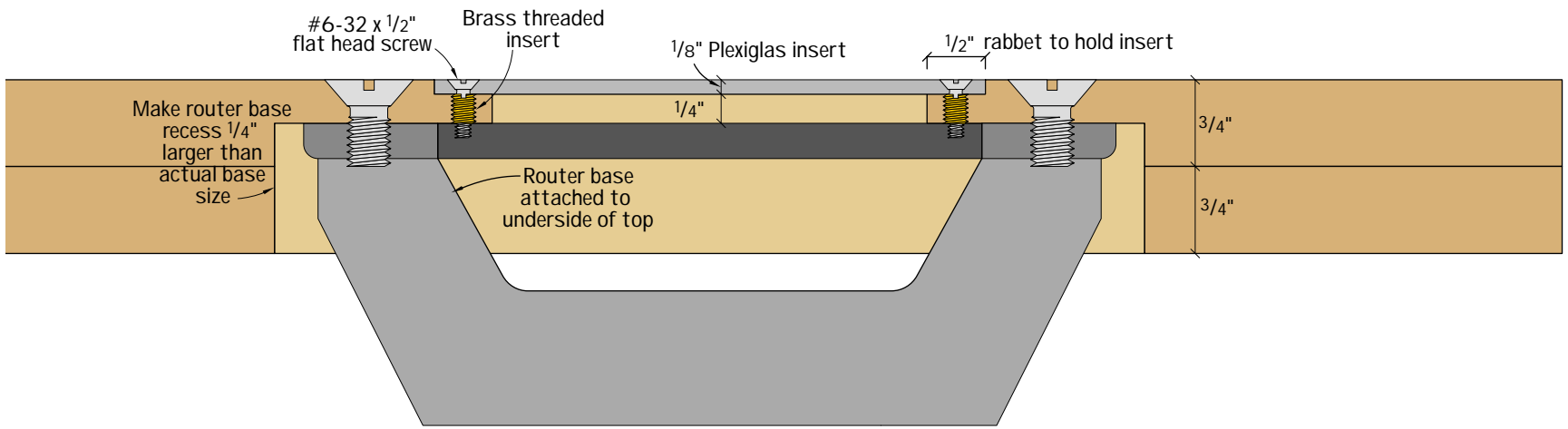

Router Table and Fence

No.	Ltr.	Item	Dimensions T W L	Material
2	A	Table top	3/4" x 23" x 35"	birch ply
1	B	Top edge banding	3/4" x 1 1/2" x 11'	solid birch
1	C	Workmate board	3/4" x 4" x 27 3/8"	any hardwood
1	D	Prop stick	3/4" x 18 3/4"	dowel stock
1	E	Prop bracket	1/2" x 1 1/2" x 4"	Baltic birch
1	F	Fence bottom	1/2" x 8" x 41"	Baltic birch
2	G	Fence sub fronts	1/2" x 3" x 12 1/2"	Baltic birch
2	H	Dust chute sides	1/2" x 4 1/8" x 8"	Baltic birch
1	I	Dust chute top	1/2" x 4" x 5"	Baltic birch
1	J	Chute angled top	1/2" x 5" x 4 3/4"	Baltic birch
1	K	Chute back	1/2" x 5" x 5"	Baltic birch
2	L	End ribs	1/2" x 2 5/8" x 3"	Baltic birch
2	M	Mid ribs	1/2" x 2 5/8" x 2 5/8"	Baltic birch
2	N	Fence adjust. front	3/4" x 4" x 16"	any hardwood

Hardware: 3, 6/32 threaded inserts and 1/2" 6/32 screws; 4 each 3/8" x 1 1/2" round head machine screws, star washers, flat washers and wing nuts, 1 pr. medium-duty loose-pin hinges. Acrylic 1/8" sheet 12" square, 1 switched plug strip.

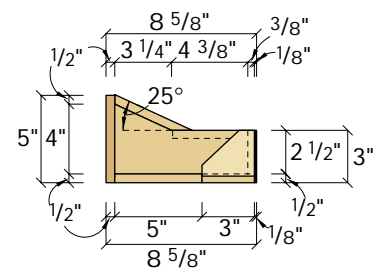
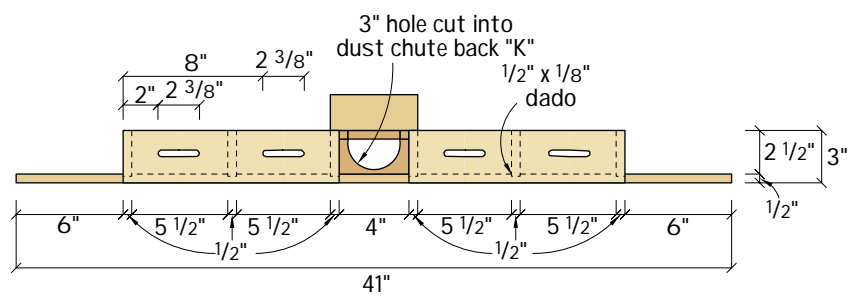
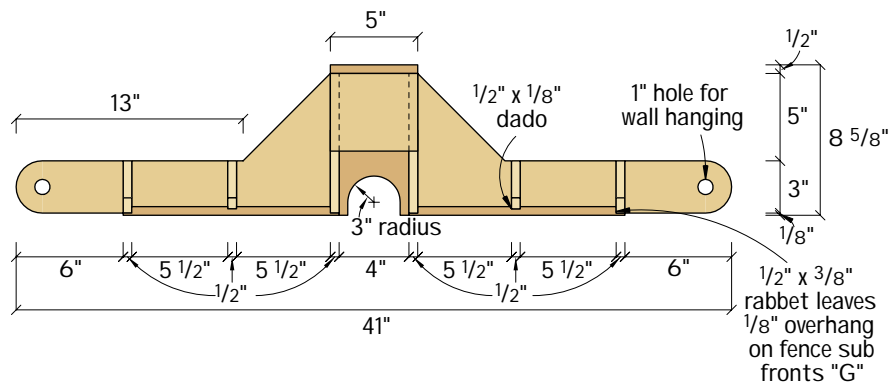
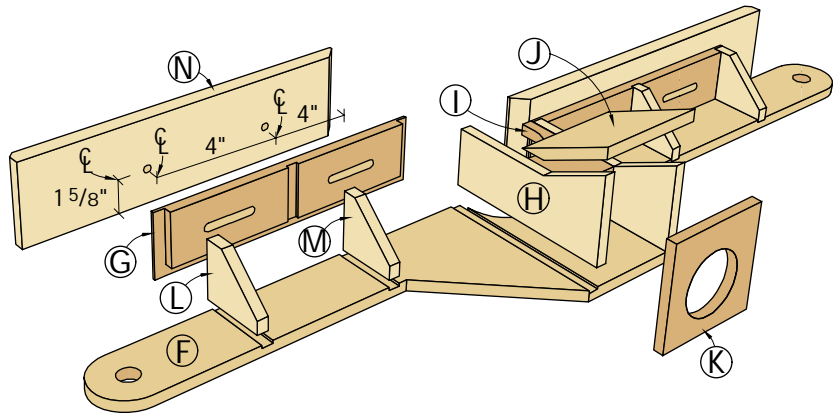

Schedule of Materials: Shelving Units

Center Case, Upper Unit				Side Case, One Upper Unit			
No.	Item	Dimensions T W L	Mat.	No.	Item	Dimensions T W L	Mat.
1	Bot rail	3/4" x 1 1/2" x 33"	P	1	Bot rail	3/4" x 1 1/2" x 21"	P
1	Top rail	3/4" x 4" x 33"	P	1	Top rail	3/4" x 4" x 21"	P
2	Stiles	3/4" x 4 3/4" x 50"	P	1	Int. stile	3/4" x 2 5/8" x 50"	P
1	Top	3/4" x 16 3/4" x 39 1/2"	Ply	1	Ext. stile	3/4" x 2 1/2" x 50"	P
3	Adj shelves*	3/4" x 16" x 38 3/4"	Ply	1	Top	3/4" x 12 3/4" x 23"	Ply
1	Bottom	3/4" x 16 3/4" x 39 1/2"	Ply	3	Adj shelves*	3/4" x 12" x 22 1/4"	Ply
2	Sides	3/4" x 17 1/4" x 50"	Ply	1	Bottom	3/4" x 12 3/4" x 23"	Ply
2	Columns	1" x 3" x 50"	P	2	Sides	3/4" x 13 1/4" x 50"	Ply
	Back	1/2" x 39 1/2" x 50"	P		Back	1/2" x 23" x 50"	P

Center Case, Lower Unit				Side Case, One Lower Unit			
No.	Item	Dimensions T W L	Mat.	No.	Item	Dimensions T W L	Mat.
1	Top rail	3/4" x 1 1/2" x 33"	P	1	Top rail	3/4" x 1 1/2" x 21"	P
1	Bot rail	3/4" x 5" x 33"	P	1	Bot rail	3/4" x 5" x 21"	P
2	Stiles	3/4" x 4 3/4" x 30"	P	1	Int. stile	3/4" x 2 5/8" x 30"	P
1	Bot	3/4" x 16 3/4" x 39 1/2"	Ply	1	Ext. stile	3/4" x 2 1/2" x 30"	P
1	Adj shelf*	3/4" x 16" x 38 3/4"	Ply	1	Bot	3/4" x 12 3/4" x 23"	Ply
1	Top rail	3/4" x 1 1/2" x 39"	P	1	Adj shelf*	3/4" x 12" x 22 1/4"	Ply
2	Sides	3/4" x 17 1/4" x 30"	Ply	1	Top rail	3/4" x 1 1/2" x 22 1/2"	P
2	Columns	1" x 3" x 30"	P	2	Sides	3/4" x 13 1/4" x 30"	Ply
	Back	1/4" x 39 1/2" x 26 1/4"	Ply		Back	1/4" x 23" x 26 1/4"	Ply

One Center Unit Door			One Side Unit Door				
No.	Item	Dimensions T W L	Mat.	No.	Item	Dimensions T W L	Mat.
2	Rails	3/4" x 2 1/2" x 12 1/2"	P	2	Rails	3/4" x 2 1/2" x 16"	P
2	Stiles	3/4" x 2 1/2" x 23 1/2"	P	2	Stiles	3/4" x 2 1/2" x 23 1/2"	P
1	Panel	5/8" x 11" x 19"	P	1	Panel	5/8" x 14 1/2" x 19"	P

* width includes dropped edge
P=Cherry • Ply=Cherry ply

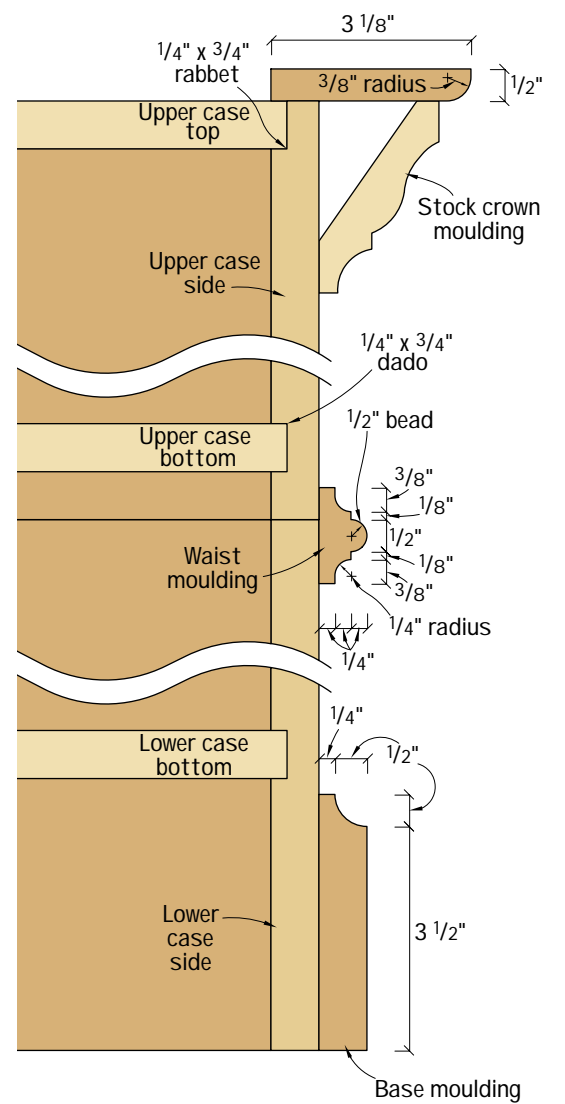
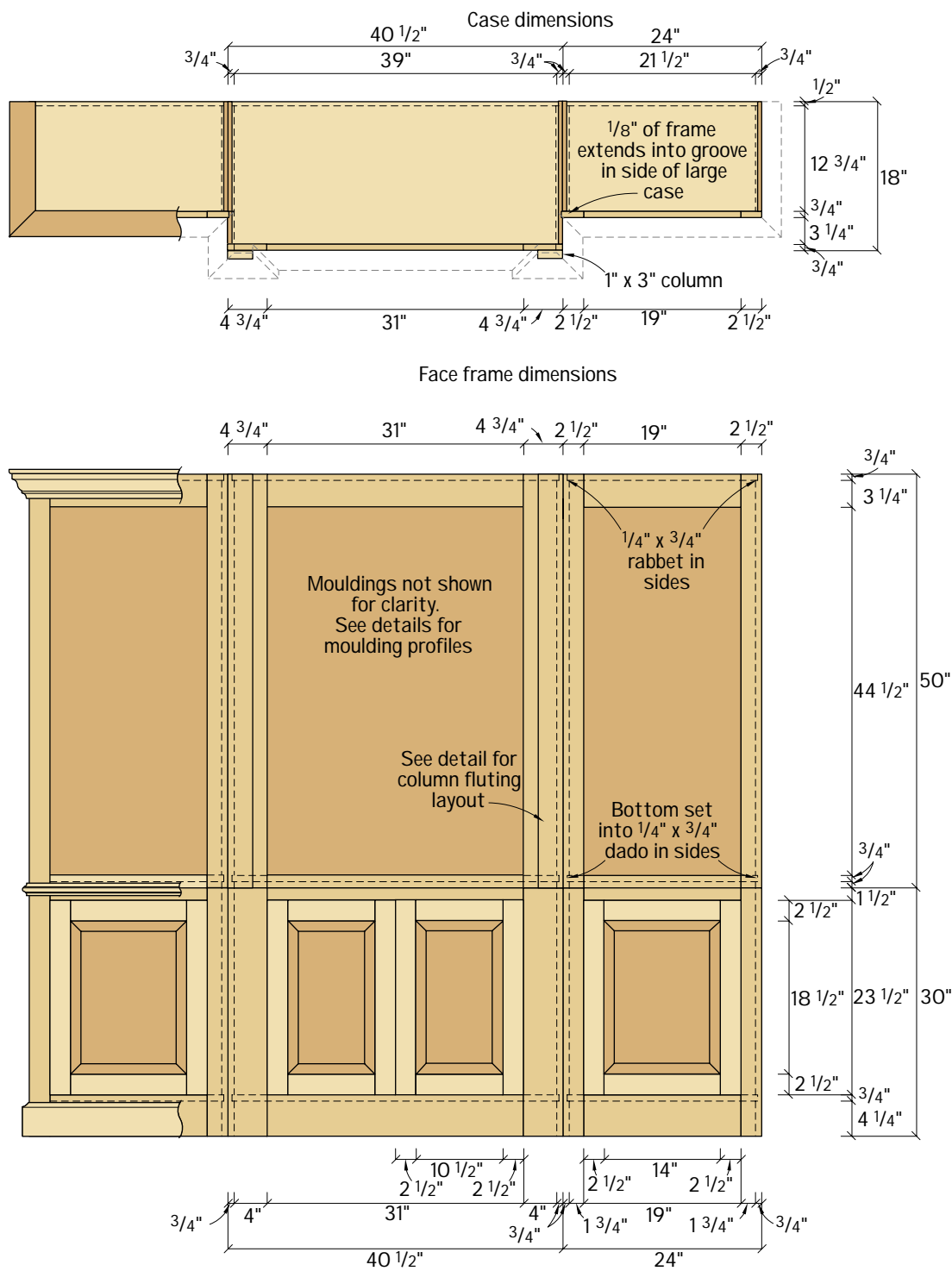

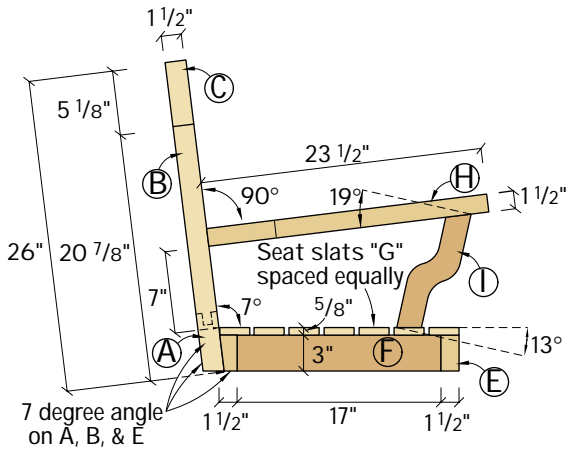

Schedule of Materials: Garden Swing

No.	Ltr.	Item	Dimensions T W L	Material
1	A	Bottom back rail	1 1/2" x 5" x 55"	Cedar
2	B	Back stiles	1 1/2" x 2 1/2" x 20 7/8"	Cedar
1	C	Top back rail	1 1/2" x 8" x 60"	Cedar
11	D	Back slats	5/8" x 2 1/2" x 20 1/2"	Cedar
2	E	Seat rails	1 1/2" x 3" x 60"	Cedar
4	F	Seat stringers	1 1/2" x 3" x 17"	Cedar
21	G	Seat slats	5/8" x 2 1/2" x 20"	Cedar
2	H	Arms	1 1/4" x 3" x 23 1/2"	Cedar
2	I	Arm supports	1 1/2" x 4" x 12"	Cedar
2	J	Table battens	3/4" x 1 1/2" x 19 7/8"	Cedar
2	K	Table legs	1" x 1 1/4" x 6 1/2"	Cedar
2	L	Table legs	1" x 1 1/4" x 8 1/4"	Cedar
2	M	Table leg braces	5/8" x 1 1/4" x 13"	Cedar
2	N	Table support cleats	1" x 2" x 20"	Cedar

*Longest slat, cut to fit. **Length oversize to allow fitting.

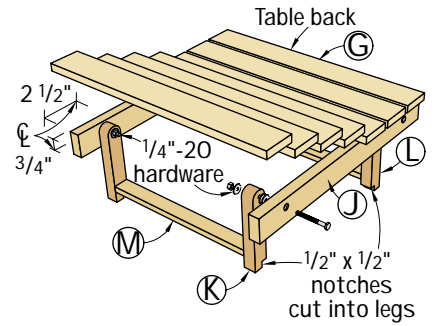
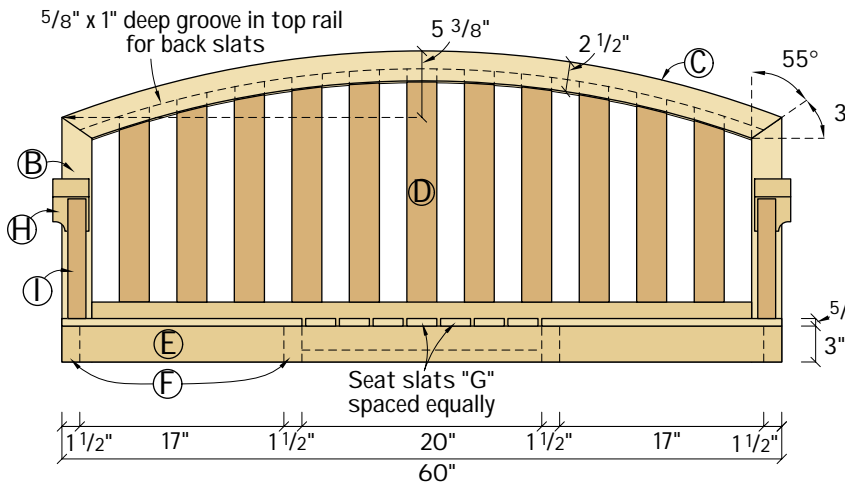

Schedule of Materials: Swing A-Frame

No.	Item	Dim. T W L	Material
4	Frame legs	4 x 4 x 96"	PTP
1	Top center rail	4 x 4 x 96"	PTP
2	Top outer rails	2 x 4 x 96"	PTP
2	Leg supports	2 x 6 x 48"	PTP
4	Swing-N-Slide EZ Frame Braces		
4	Swing-N-Slide Leg top braces		
2	3/8" x 6" eye bolts		
4	3/8" flat washers		
4	3/8" nuts		
8	S-connectors		
4	6-foot lengths of chain		

PTP = pressure treated pine

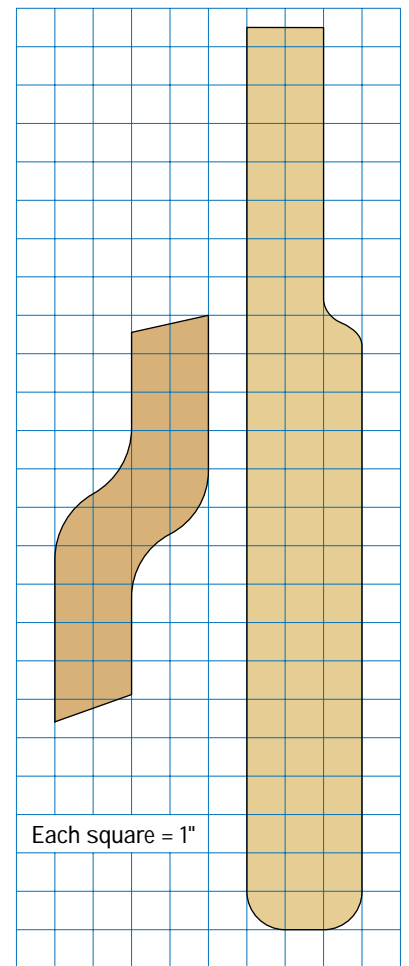

Each square = 1"

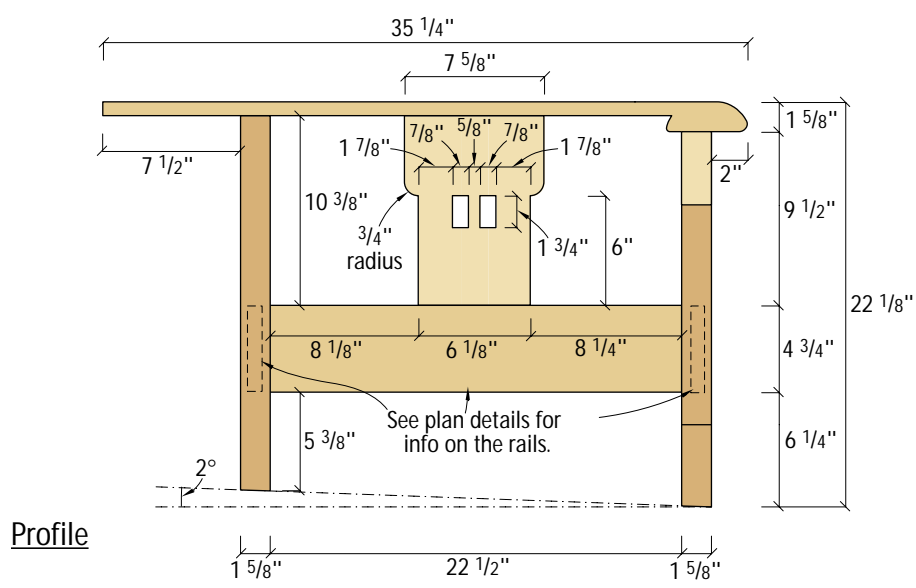

Profile

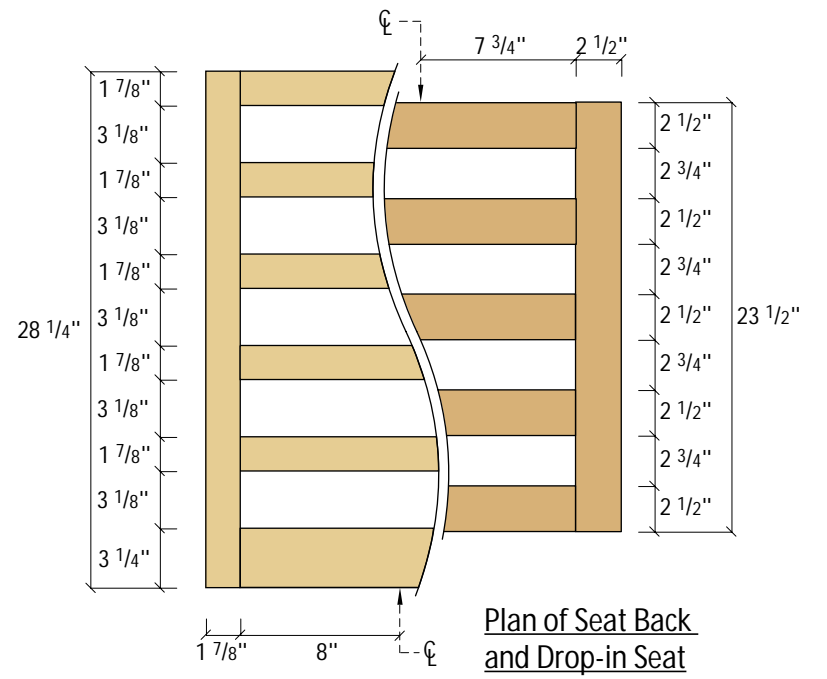

Plan of Seat Back and Drop-in Seat

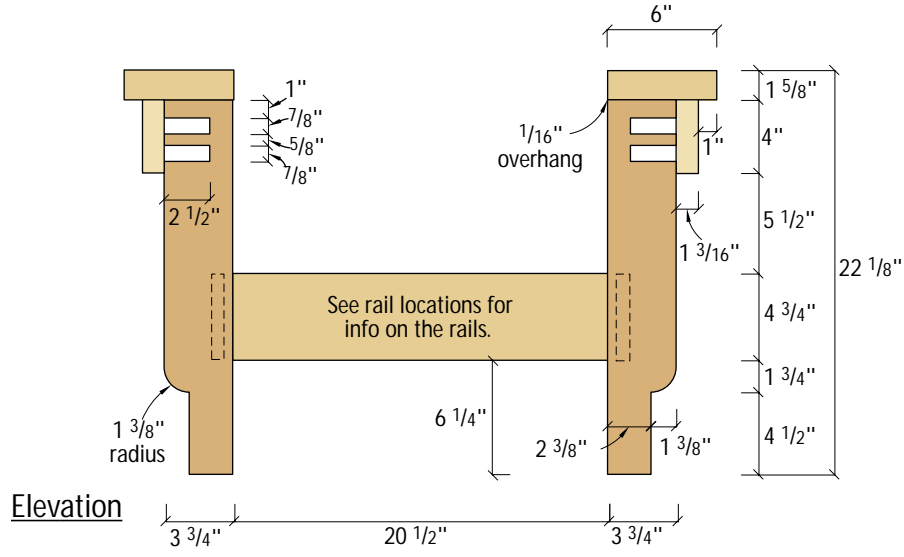

Elevation

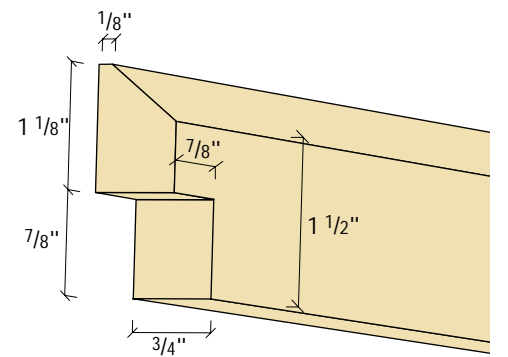

Back Rod

MORRIS CHAIR

NO.	ITEM	DIMENSIONS (INCHES)			NOTES
		T	W	L	
Chair frame					
2	Front legs	1 5/8	3 3/4	21	1/2" TOE
2	Back legs	1 5/8	2 1/4	21	1/2" TOE
2	Applied sides	1 5/8	1 3/16	4	
1	Front rail	3/4	4 3/4	22	3/4" TBE
2	Side rails	3/4	4 3/4	24	3/4" TBE
1	Back rail	7/8	4 3/4	22	3/4" TBE
2	Side slats	1/2	7 5/8	11 3/8	1/2" TBE
2	Arm bldps	7/8	6	4 1/2	
2	Arms	3/4	6	35 1/4	
2	Cleats	3/4	1 7/8	20 1/2	
1	Back rod	3/4	2	23 5/16	
Drop-in seat					
2	Seat stiles	3/4	2 1/2	23 1/2	
5	Seat rails	3/4	2 1/2	17	3/4" TBE
Adjustable back					
2	Back stiles	3/4	1 7/8	28 1/4	
5	Back rails	3/4	1 7/8	17 1/2	3/4" TBE
1	Bottom rail	3/4	3 1/4	17 1/2	3/4" TBE

TOE = tenon on one end • TBE = tenon on both ends

SUPPLIES

Slotted Piano Hinge
 Rockler: 800-279-4441 or rockler.com

 J.E. Moser's Golden Amber Maple water-based aniline dye
 Woodworker's Supply:
 800-645-9292 or woodworker.com

 Lilly Professional Glaze, choose the color "warm brown"
 Woodfinishingsupplies.com:
 507-280-6515 or woodfinishingsupplies.com

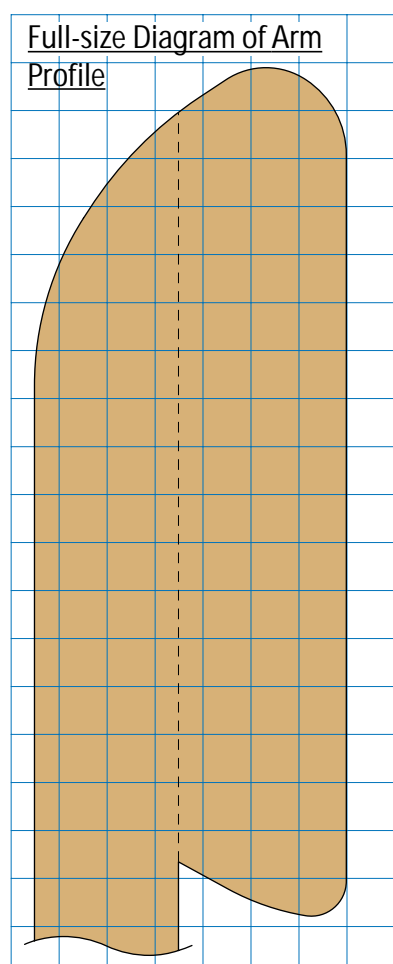

Full-size Diagram of Arm Profile

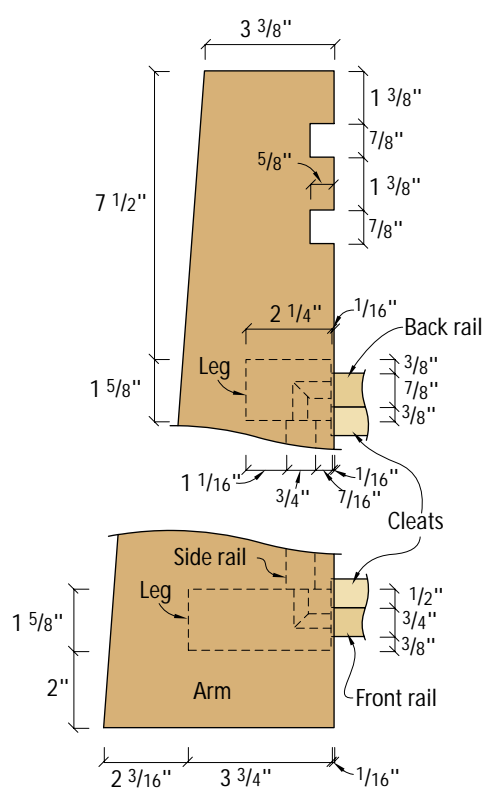

Rail Locations

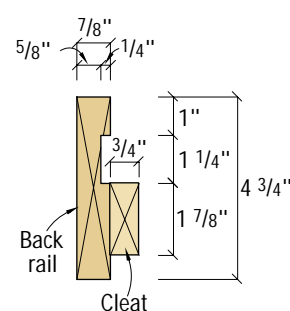

Cleat Location, Back Rail

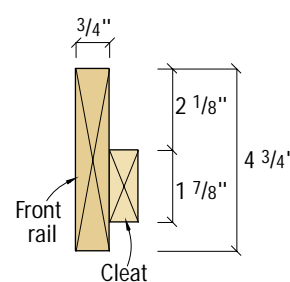

Cleat Location, Front Rail

The "X" on the rails and cleats denotes a cross section rather than an end view.

Schedule of Materials Step Tansu

Lower Cabinet

No.	Item	Dimensions T W L	Material
2	Top & bot.	3/4" x 17" x 51"	Ply
4	Cabinet stiles	1" x 2" x 16"	M
2	Side panels	3/4" x 15" x 16"	Ply
1	Back panel	3/4" x 16" x 47"	Ply
4	Dr stiles	3/4" x 2" x 16"	M
4	Dr rails	3/4" x 2" x 21"	M
2	Thin rails	3/4" x 1" x 21"	M
2	Top panel	1/4" x 7 ¹ / ₁₆ " x 21"	Ply
2	Lower panel	1/4" x 4 ¹¹ / ₁₆ " x 21"	Ply
4	Interior stiles	1/4" x 1" x 7"	M
4	Runners	1/4" x 1/4" x 46"	M
1	Partition	3/4" x 13" x 16"	Ply
3	Cleats	3/4" x 3/4" x 13"	M

Upper Cabinet

No.	Item	Dimensions T W L	Material
2	Top & bot.	3/4" x 13" x 31"	Ply
4	Cabinet stiles	1" x 2" x 11"	M
2	Side panels	3/4" x 11" x 11"	Ply
1	Back panel	3/4" x 11" x 27"	Ply
2	Vert dividers	3/4" x 10 ¹ / ₂ " x 11"	Ply
4	Lg drw frts	3/4" x 4" x 8"	M
8	Drw sides	1/2" x 4" x 10 ¹ / ₈ "	Ply
4	Drw backs	1/2" x 4" x 7 ¹ / ₂ "	Ply
6	Drw bot	1/4" x 7 ¹ / ₂ " x 9 ³ / ₄ "	Ply
2	Sm drw frts	3/4" x 3" x 8"	M
2	Drw sides	1/2" x 3" x 10 ¹ / ₈ "	Ply
4	Drw backs	1/2" x 3" x 7 ¹ / ₂ "	Ply

M= Hard maple, Ply= Maple plywood

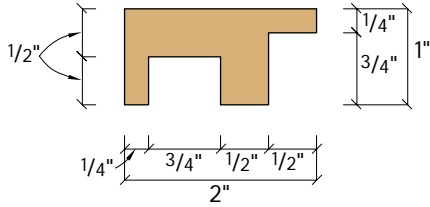

Detail of back cabinet stiles

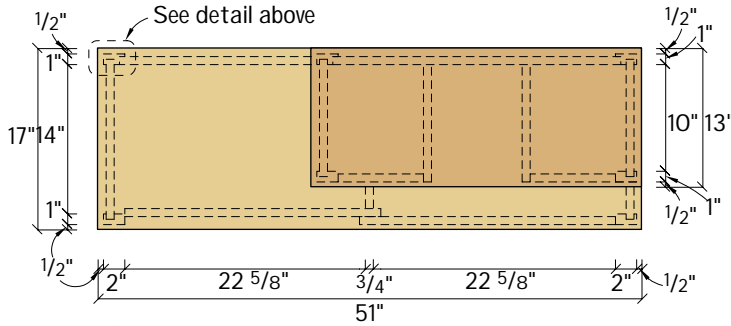

Plan

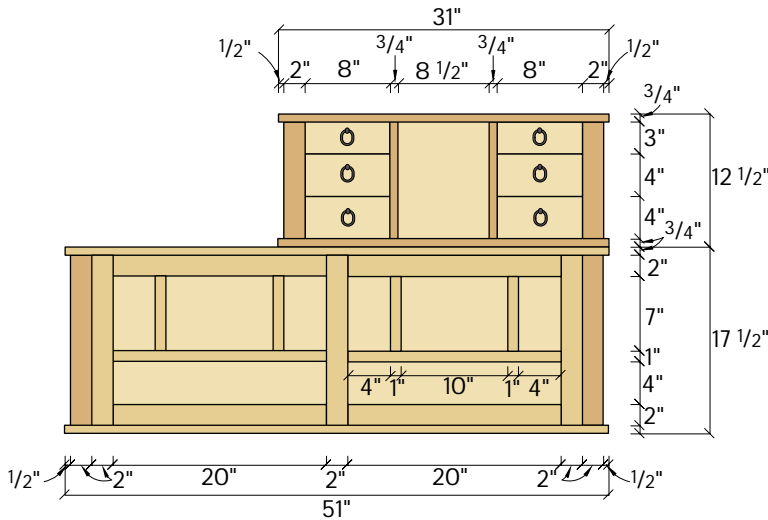

Elevation

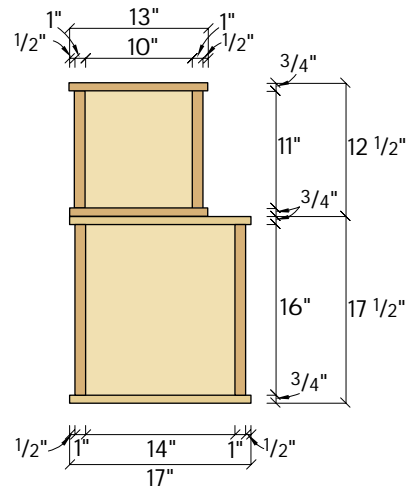

Profile

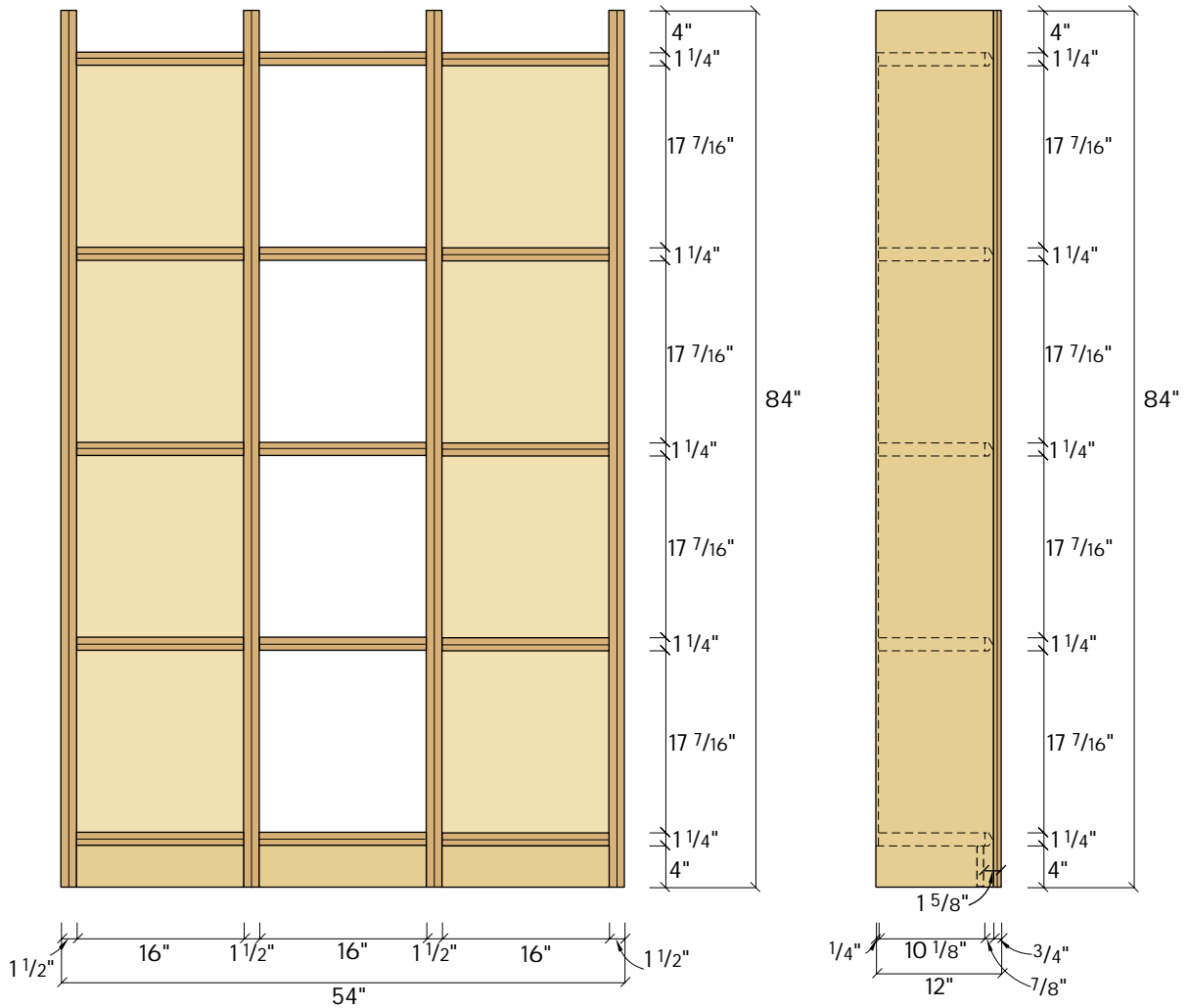

Elevation

Profile

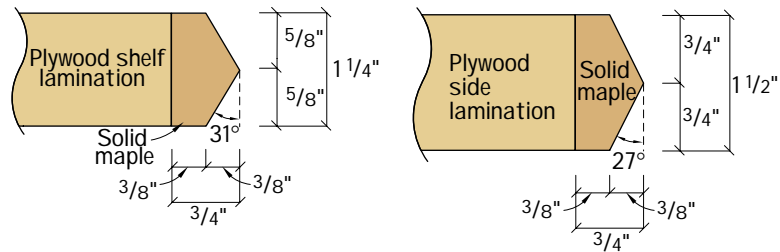

Detail of bevel profiles

Schedule of Materials: Contemporary Shelves

No.	Item	Dimensions T W L	Material
4	Sides	3/4" x 11 1/4" x 84"	Plywood
4	Sides	3/4" x 11" x 84"	Plywood
10	Outr. shelf tops	3/4" x 10 1/8" x 16"	Plywood
10	Outr. shelf bottoms	1/2" x 10 1/8" x 16"	Plywood
5	Cntr. shelf tops	3/4" x 10 3/8" x 16"	Plywood
5	Cntr. shelf bottoms	1/2" x 10 3/8" x 16"	Plywood
2	Backs	1/4" x 17 1/2" x 76"	Plywood
3	Aprons	3/4" x 4" x 16"	Plywood
4	Side edging	3/4" x 1 1/2" x 84"	Maple
15	Shelf edging	3/4" x 1 1/4" x 16"	Maple

Supplies: Woodworkers' Supply (800-645-9292), 12 6" taper connectors, # 928273 \$4.95/pkg. of four. 18 wire shelf supports, # 826028, \$1.45 apiece for 10+.

Schedule of Materials: Drill press table

No.	Let.	Item	Dimensions T W L	Material
1	A	Platform	3/4" x 20" x 29"	Plywood
1	B	Fence	1 1/2" x 2 3/4" x 30"	Hardwood
2	C	Fence base plates	3/4" x 3" x 9"	Plywood
4	D	Base plate braces	3/4" x 3" x 1 7/8"	Hardwood
2	E	Stops	3/4" x 2 1/2" x 2 1/2"	Hardwood
2	F	Hold-down plates	3/4" x 1 1/2" x 3"	Hardwood
1	G	Insert plate	3/8" x 4" x 4"	Plywood
2	Part #88F05.02 DeStaCo clamps — \$14.50 ea.			
6	Part #12K7901 24" T-slot track — \$4.95 ea.			
8	Part #00M5102 1 1/8" 3-wing knobs — \$6 for 10			
8	Part #05J2115 T-nuts — \$1.15 for 10			
All hardware available from Lee Valley 800-871-8158				

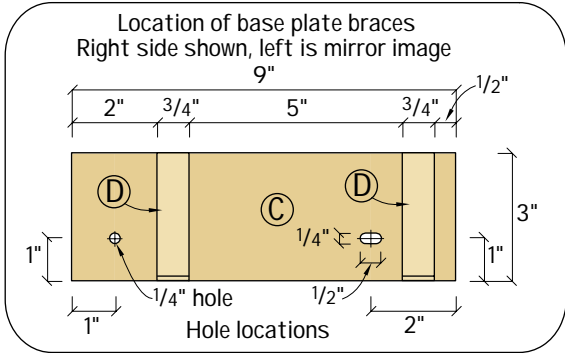

Plan detail of hole locations for base plate

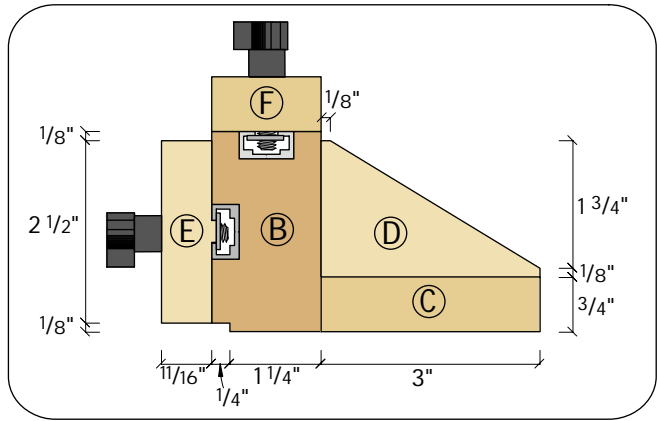

Detail of Fence Profile

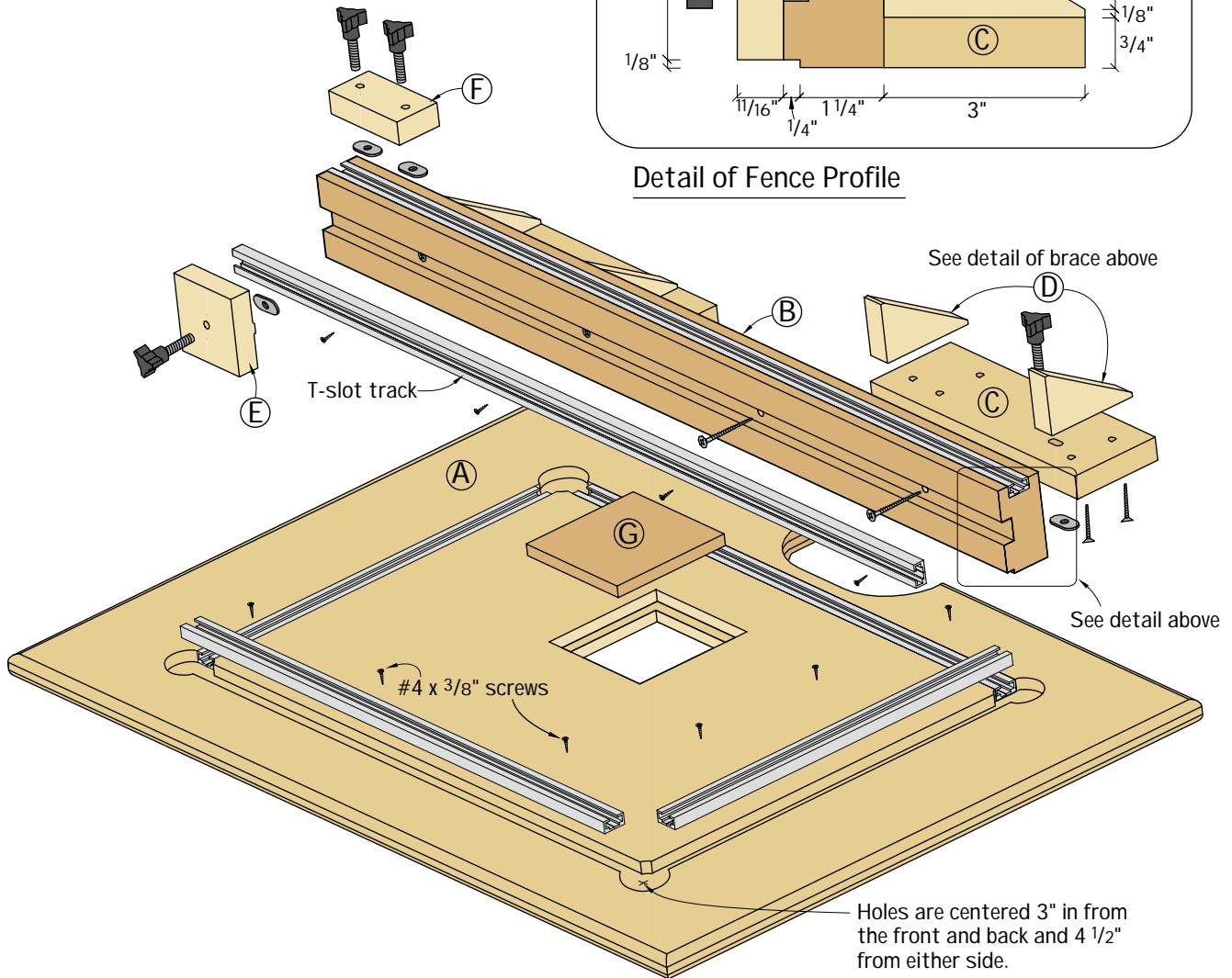

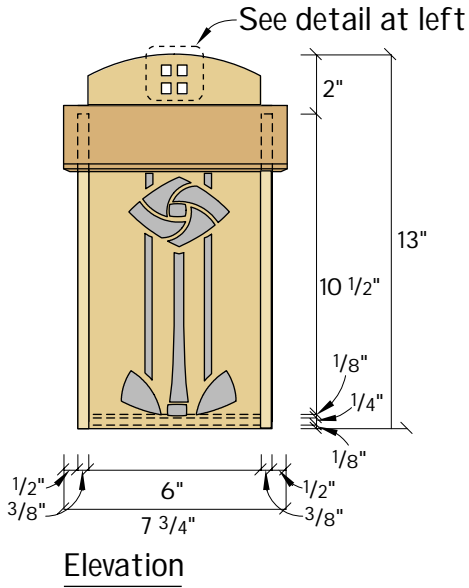
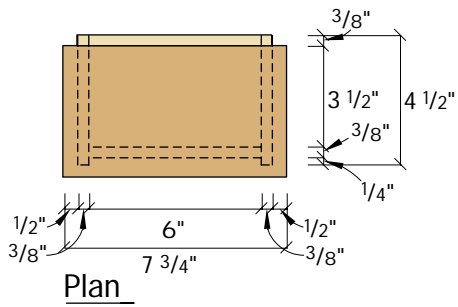

Schedule of Materials: Bungalow Mailbox				
No.	Item	Dimensions	T W L	Material
2	Sides	$\frac{3}{8}$ " x $4\frac{1}{2}$ " x 11"		White oak
1	Front	$\frac{3}{8}$ " x 6" x 9"		White oak
1	Back	$\frac{3}{8}$ " x 6" x 13"		White oak
1	Bottom	$\frac{3}{8}$ " x $3\frac{11}{16}$ " x $5\frac{7}{8}$ "		White oak
1	Top	$\frac{3}{8}$ " x 5" x $7\frac{3}{4}$ "		White oak
1	Applied detail	$\frac{1}{8}$ " x 6" x 9"		White oak
2	- 12" lengths of $\frac{3}{4}$ " copper pipe			

Bungalow Mailbox

Full-size diagram of
rose and stemleaf
parts

