



# TRAPEZOIDAL BOOKCASE

I don't think I've ever built a perfect reproduction. Even when I really like an existing design, I need the piece to be slightly larger, I prefer some technique over one used in the original construction, or I don't have the exact materials. In any case, I think that one of the more enjoyable aspects of woodworking is trying new ideas and combinations. So it is with this bookcase, and twice over.

I based the design of this bookcase on one made by David Fay, a furniture maker in Oakland, California, who based his design on a turn-of-the-century Roycroft magazine pedestal. David's version strayed from the original somewhat, and my design strays from David's. The results are three ver-

sions of the same bookcase, with an overall look in common.

As is the case with much Arts and Crafts furniture, the essential decorative elements of all versions of this piece are the construction details, including the canted sides for stability and the wedged, locking through-tenons. In his interpretation of the original, David left these elements intact, but he omitted the molded crown and used cherry (instead of fumed white oak) and contrasting panga panga wood wedges and shelf supports.

My bookcase is identical to David's, but I used ash with zebrawood for the wedges. I also made mine knockdown for transporting.

# Trapezoidal Knockdown Bookcase

THIS IS AN UPDATED, KNOCKDOWN VERSION of a Roycroft magazine stand held together with through wedge tenons on the top and bottom shelves. The middle shelves are held in position with unglued biscuits. The front edges of the sides are tapered 3 degrees, and the sides also lean toward each other at 3 degrees, giving the piece a trapezoidal shape.

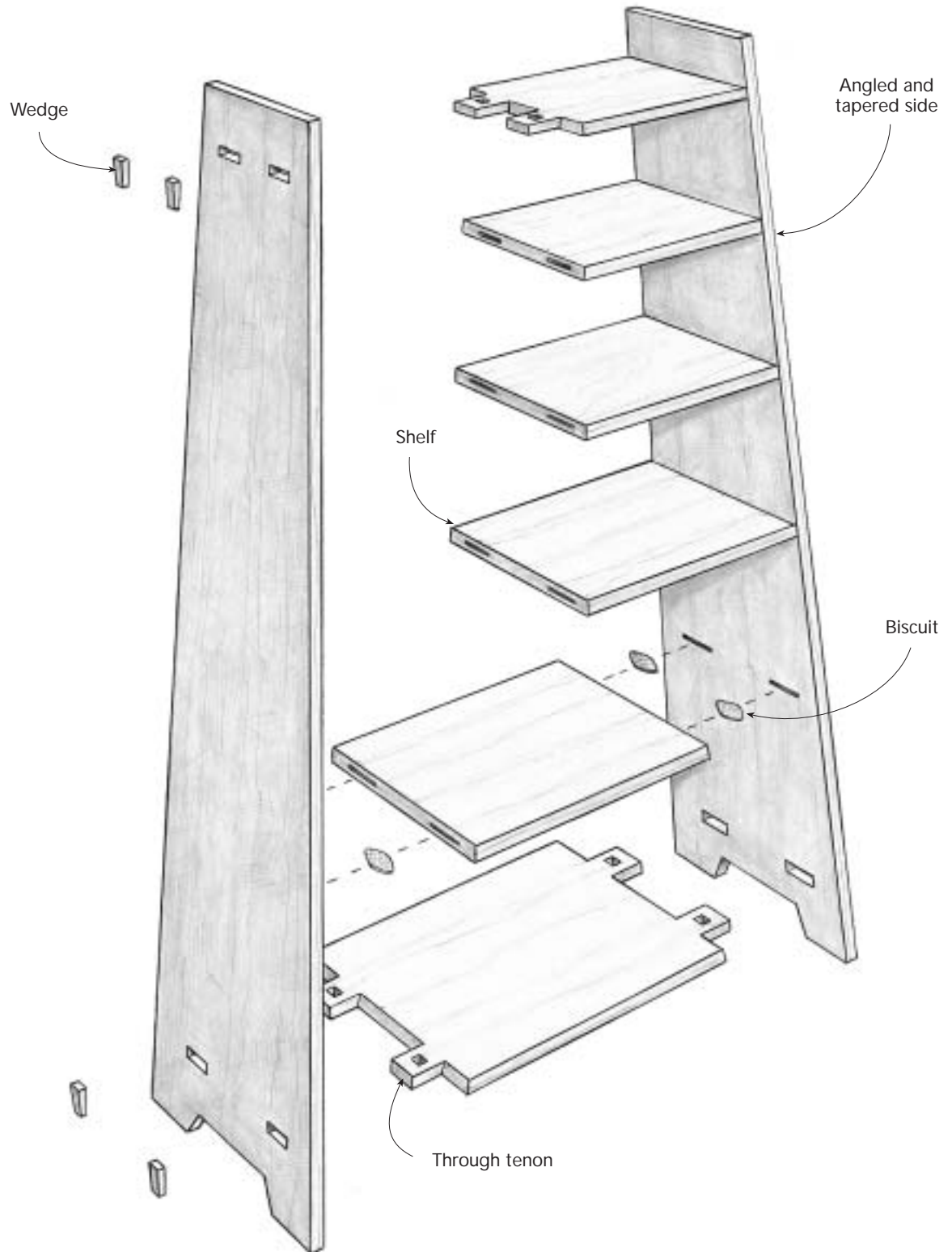

FRONT VIEW

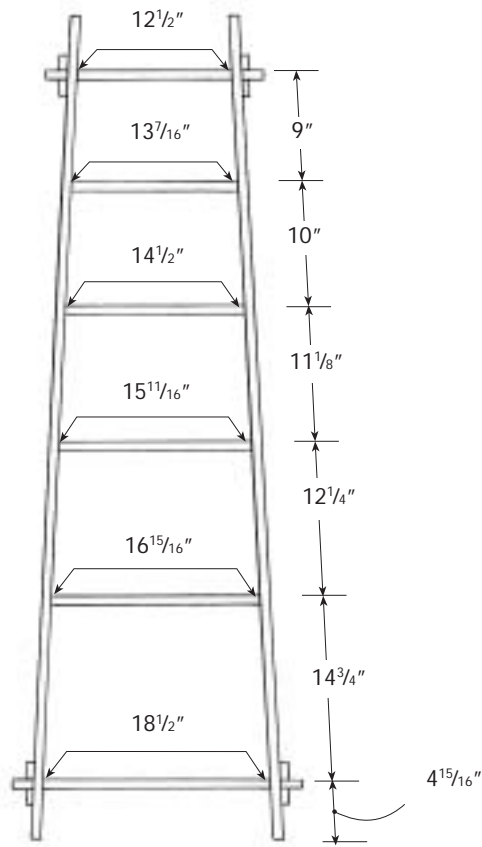

SIDE VIEW

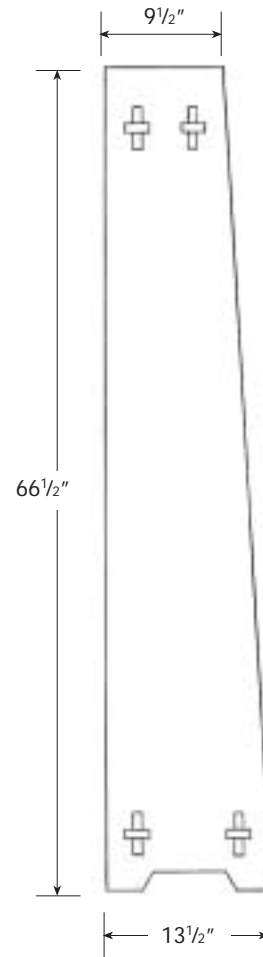

Sides and shelves are 3/4" thick.

## CUT LIST FOR TRAPEZOIDAL BOOKCASE

### Carcase and Shelves

2	Sides	13 1/2 in. x 66 5/8 in. x 3/4 in.
1	Shelf	13 7/16 in. x 10 5/16 in. x 3/4 in.
1	Shelf	14 1/2 in. x 10 15/16 in. x 3/4 in.
1	Shelf	15 11/16 in. x 11 7/16 in. x 3/4 in.
1	Shelf	16 15/16 in. x 12 5/16 in. x 3/4 in.
1	Top shelf	17 1/2 in. x 9 3/4 in. x 3/4 in.
1	Bottom shelf	23 1/2 in. x 13 1/4 in. x 3/4 in.
8	Wedges	3 3/8 in. x 3/4 in. x 3/4 in.

All parts are made of solid ash except for the zebrawood wedges.

# BUILDING THE BOOKCASE STEP-BY-STEP

**T**HIS BOOKCASE would be a cinch to build except for the 3-degree trapezoidal shape. All of the joinery must be cut at this angle, often with special-made jigs. The best place to begin is with a full-sized drawing of the bookcase (front and side views) on a good-quality light-colored plywood. It will be an excellent and accurate reference throughout the whole building process (see “Full-Scale Drawings”).

## FULL-SCALE DRAWINGS

Full-scale drawings may seem like overkill, but they are tremendously useful, especially when the piece is complex.

An accurate full-scale drawing lets you take all your measurements from it as you work. You don't have to fiddle with cut lists and calculate joints and details in your head. Just put a ruler on the drawing, and you have your measurement.

They're also helpful to visually evaluate the size and proportions of the piece. If you want to adapt a design to a different space or to hold some specific objects, the full-scale drawing helps you see what it will look like. Scale drawings can tell you only so much. Subtle changes that would be all but invisible in a small drawing can be quite dramatic full size.

To transfer angles from the drawing to a workpiece or machine, use a large protractor gauge, such as one made by CCKL Creator (available from Lee Valley Tools). It is much larger than a standard bevel gauge, and it allows a greater reach on the drawing and greater accuracy. It also allows you to read the actual angle. This makes resetting it a cinch, which isn't necessarily the case with a standard bevel gauge.

## MAKING THE SIDES AND SHELVES

### Gluing up the stock

The smallest shelf is 9¼ in. deep, and the base of the sides is 13½ in. Unless you have access to some wide ash, you'll have to make the shelves and sides from two pieces.



**Photo A:** The bookcase sides and shelves are wide (9½ in. to 13½ in.), and have to be glued up from two or more pieces.

1. If you can, resaw 8/4 stock for the sides and book-match them. I couldn't book-match the bookcase you see in the photos with the ash I had, but it is certainly worth the trouble.
2. If you use unmatched boards, choose the best match of grain and color for the sides, and decide if you want the glue joint parallel with the straight back or with the tapered edge on the front. I chose parallel to the back, which seemed the least obvious.
3. Glue up all the stock for the bookcase shelves and sides at once (see **photo A**).

### Beveling ends and tapering sides

1. Cut the sides to length, but not at 90 degrees. The sides lean inward toward each other at 3 degrees, so crosscut the top and bottom edges at 93 degrees to the floor (or 87 degrees, depending from which direction you measure). This way when the bookcase sits on the floor, the bottom sits flat and the top edges are horizontal. Make sure the edges are parallel when finished.
2. The front edge of the bookcase has a taper (though the back does not). Lay it out by measuring from the back edge of each side 13½ in. at the bottom and 9½ in. at the top. Then draw a line between the marks.
3. Cut the taper along the line. I use a Festo circular saw that has a straightedge guide that's great for this kind of cut. It leaves a very smooth and straight edge (see **photo B**). The taper can also be rough-cut with a jigsaw and cleaned up with a straightedge and a router.
4. Cut the top and bottom shelf blanks a little wider than necessary and 3½ in. longer than the outside width of the case at their locations. This allows for the through tenons.
5. Later, after these shelves are installed, mark the exact depth from the sides, then rip a 3-degree bevel on the front edge. Then rip the back edge at 90 degrees.



**Photo B:** A circular saw and straightedge guide make cutting the tapers on the sides a cinch.

## JOINERY

### Cutting the mortises

The mortises that are used to join the top and bottom shelves to the sides are the trickiest part of this piece because they are angled and have to be cut cleanly to within a very close tolerance—as does all the joinery in this piece—because it all shows.

1. Make two router jigs, a right-handed one and a left-handed one, to cut the four mortises in the sides at a 3-degree angle (see “Jig for Routing Angled Mortises” on p. 86).
2. Attach the alignment fence to the left-handed jig on the angled edge. It is now set up to cut the mortises on the front edge of the left side.
3. Position the jig flush with the top and front edges on the outside face of the left side.

**Tip:** Standard bevel gauges should be set once and left set until you've finished with every similar angle. However, to give memory to a bevel gauge, trace the whole blade of the bevel gauge on a scrap of plywood.

# Jigs for Routing Angled Mortises

To cut the four mortises in the sides, you need two jigs with movable fences. The jigs are identical except that they are mirror images of each other. One edge of each jig is angled like the front edge of the bookcase, and the bottoms of each are shimmed at 3 degrees, the same angle that the bookcase sides lean inward.

Jigs sit in the corners of their respective sides, and register off the edges to locate the mortises.

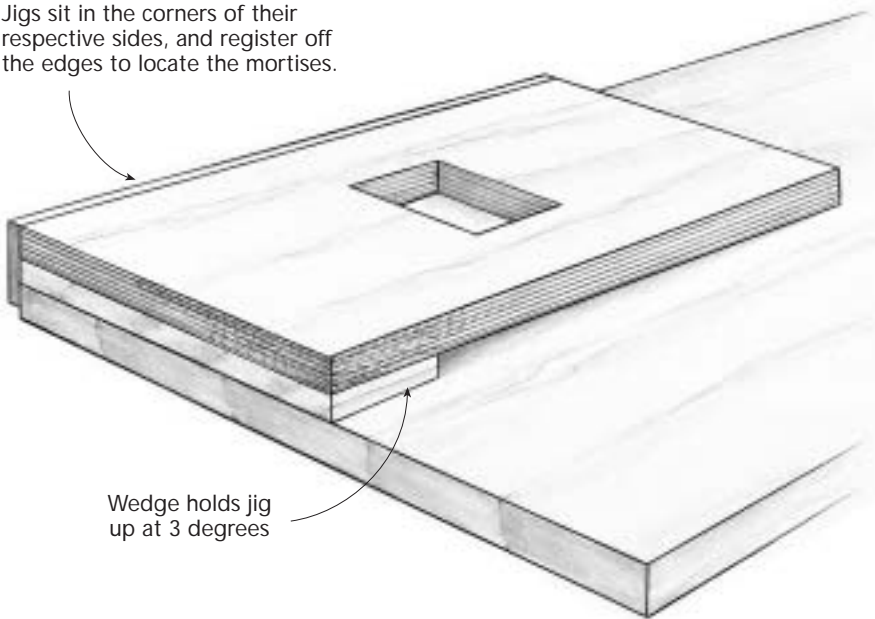

Wedge holds jig up at 3 degrees

LEFT-SIDE JIG

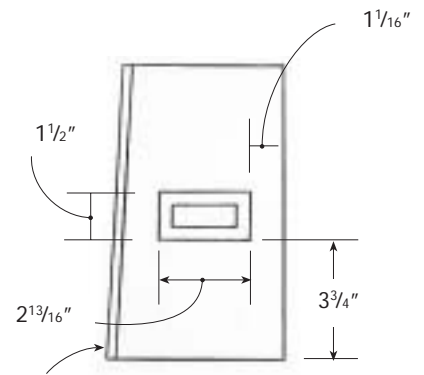

Alignment fence can be moved from front to back edge of jig for corresponding location on bookcase side.

RIGHT-SIDE JIG

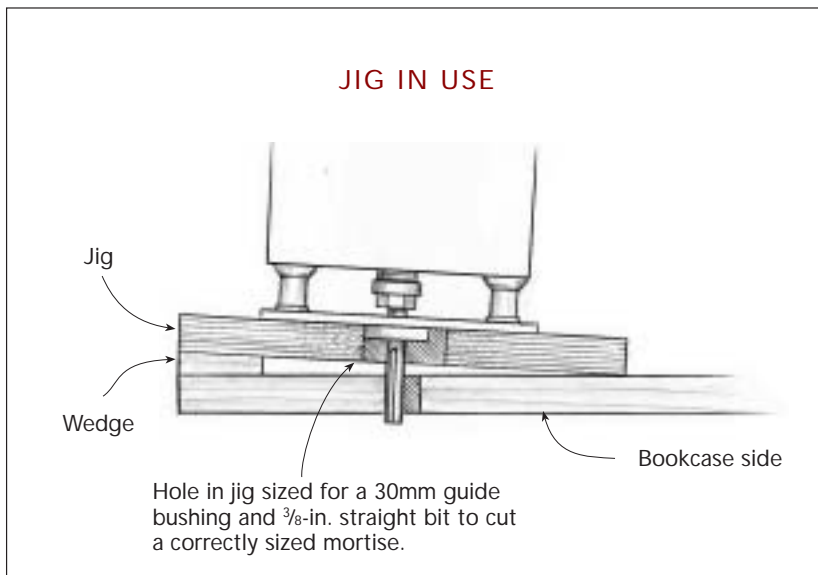
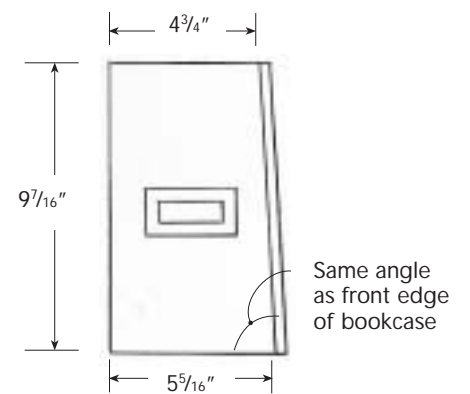



**Photo C:** To cut the through mortises in the sides, you need a left-handed and a right-handed router jig.

**Tip:** Attach the jig to the workpiece with double-sided tape rather than clamps because they can get in the way of the router.



**Photo D:** The mortising jig tilts the router 3 degrees and cuts the mortise walls at the same angle.

4. Back up the cut on the underside with some scrap wood. Don't risk any tearout since everything shows.
5. Cut the upper mortises on the front edge of the left side with a plunge router. Advance the depth of cut in very small increments.
6. Slide the jig down the same side until it is flush with the bottom, and cut the bottom mortise on the same side (see **photo C**).
7. Take the alignment fence off the jig and attach it to the opposite side of the jig.
8. Move the jig to the back side and repeat the process for the back mortises (see **photo D**).
9. Square up the rounded mortise corners with a sharp chisel (see **photo E**).
10. Repeat this process on the other side of the bookcase but with the other jig.



**Photo E:** Square up the routed mortises with a sharp chisel.



# Cut Sequence for Tenons

A support box attached to a crosscut sled makes a stable platform to cut tenons. A stop block lets you angle the workpiece.

## STEP 1: CUT CHEEKS

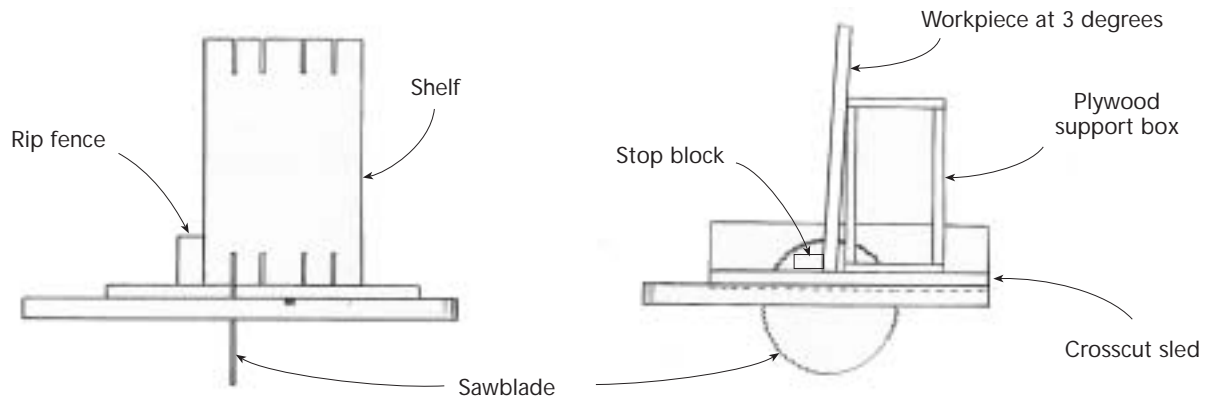

## STEP 2: CUT SHOULDERS

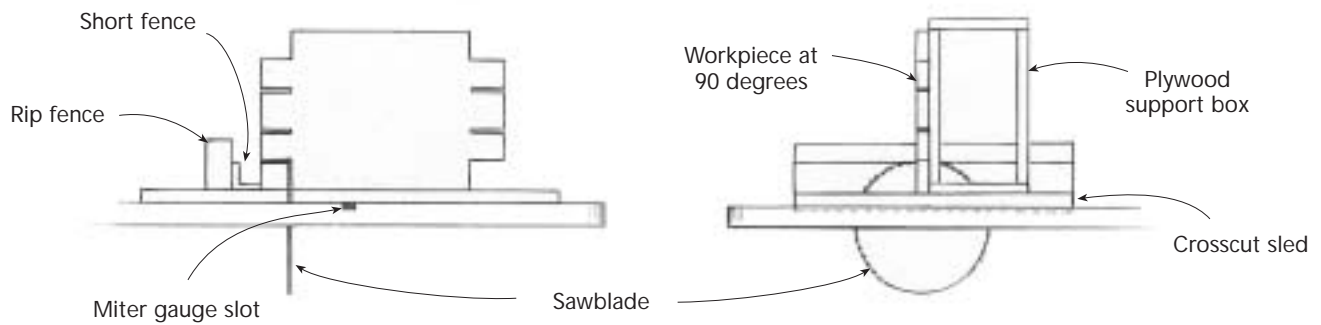

## STEP 3: REMOVE CENTER PORTION

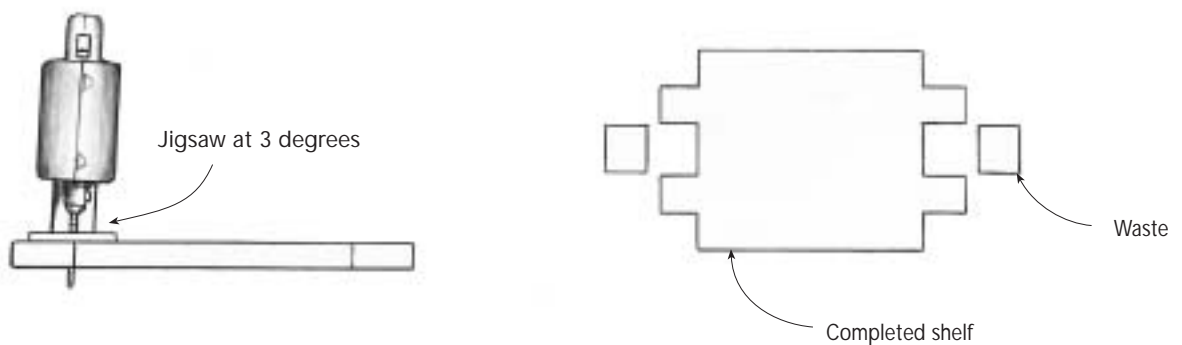

## Cutting the tenons in the top and bottom shelves

Choosing one method of tenoning over another is usually based on experience and machinery. I use my table saw because I'm comfortable with this machine and it produces a cut that requires the least amount of cleanup. However, feel free to cut the tenons as you like.

1. Attach a tall fence (actually a plywood box) to your table-saw crosscut sled at right angles to the blade.
2. Attach a stop block to the sled, in front of and parallel to the fence. This stop block is positioned to catch the edge of the workpiece that, when leaned back against the fence, is at 3 degrees to the top of the saw (see "Cut Sequence for Tenons").
3. Use the saw fence to position the cut, and raise the blade to a height that corresponds to the length of the tenon.
4. Push the sled across the blade to cut what are essentially the cheeks of the tenons (see **photo F**).
5. To cut the tenon shoulders, use the same jig, but with the stop block removed and the box fence pivoted 3 degrees relative to the sawblade (see **photo G**).



**Photo F:** A simple table-saw jig positions the workpiece to cut the angled cheeks of the tenons.

6. Place a short fence against the rip fence to position the cut and allow the cutoff to fall clear of the blade and fence.
7. Hold the workpiece against the fence (90 degrees to the saw table and 3 degrees to the blade).
8. With the sawblade just high enough to connect with the previous cut, push the sled across the blade, making the shoulder cuts.
9. Cut out the center portion with a jigsaw, with the blade set at 3 degrees.



**Photo G:** To cut the outside tenon shoulders, reposition the box fence 3 degrees to the blade.



**Photo H:** Clean up the jigsaw cut with a chisel.

**Tip:** Remember that the outer wedge faces have to be perpendicular to the shelf (which is horizontal) to seat against the vertical outer walls of the mortise.



**Photo I:** A hollow-chisel mortiser with a  $\frac{3}{8}$ -in. bit is fast and accurate for cutting the mortises for the wedge.

10. Pare to the layout lines on each side with a sharp chisel, making sure to maintain the 3-degree angle across the shoulder (see photo H on p. 89).

### Cutting the mortises in the tenons for the wedges

In a perfect world, the wedges would be simple to fit in the tenons, needing only accurate measurements and layout. In reality, there is a lot of fitting to get the wedges just right. Differences in the size of the mortise as little as  $\frac{1}{32}$  in. can cause the height of the wedge to vary as much as  $\frac{1}{4}$  in.

1. Check the fit of the mortises and tenons and make any adjustments necessary.
2. Assemble the case with just the top and bottom two shelves and clamp it tightly together.
3. Precisely mark the parts of the tenons that protrude past the sides. From these marks, lay out the mortises in the tenons that will accept the wedges.
4. Lay out the mortises as wide as the wedges and  $\frac{3}{4}$  in. deep. Though the wedges are only  $\frac{9}{16}$  in. thick where they sit tight in the mortises, you don't want them to bottom out in their holes before they pull the shelf up tight.

### WEDGED TENON DETAILS

FRONT VIEW

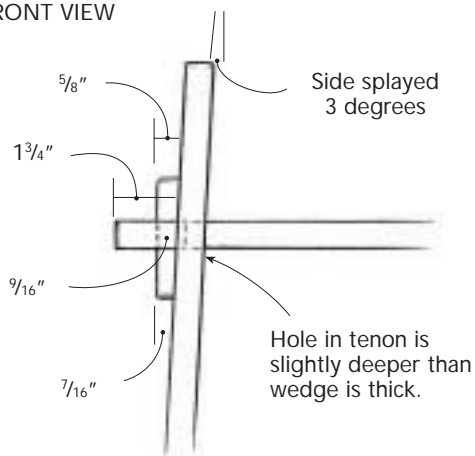

SIDE VIEW

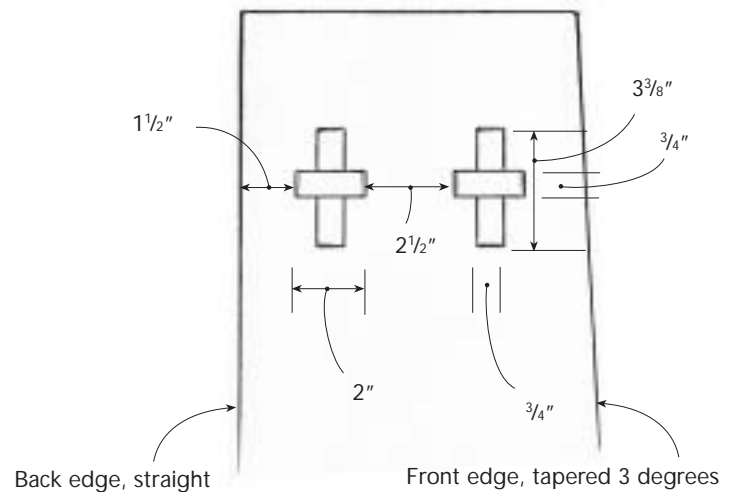

5. Working on the top of the shelves, measure out  $\frac{9}{16}$  in. from the marks on the tenons, draw a line, then measure back  $\frac{3}{4}$  in. and draw another line.

6. Measure out from the center of these lines  $\frac{3}{8}$  in. in each direction and connect your marks. This gives you a  $\frac{3}{4}$ -in. by  $\frac{3}{4}$ -in. hole for each wedge (see “Wedged Tenon Details”).

7. Clamp a waste board under each tenon to prevent tearout on the opposite face when you cut the mortises.

8. Cut the mortises at 90 degrees using a  $\frac{3}{8}$ -in. bit in a hollow-chisel mortiser. Nibble away at the edges of the holes until you reach the lines (see **photo I**). A mallet and chisel will do the work as well, though more slowly.

9. When you're finished cutting all the holes, clean them up with a small file.

## Making and seating the wedges

Make the wedges only after the mortises are cut. It's far easier to adjust the wedge to fit the mortise than the other way around.

1. Rip and plane some  $\frac{3}{4}$ -in.-square strips of zebrawood and cut them into  $3\frac{3}{8}$ -in. lengths (make sure you cut a few extra).

2. Make a small, simple carrier jig to hold the wedges when you cut the tapers on the bandsaw (see “Bandsaw Jig for Tapering the Wedges”). This jig ensures that all the wedges are exactly the same size so they fit into their holes in the same way.

3. Cut the tapers with the jig on the bandsaw.

4. Sand the cut edges of the wedges with a piece of sandpaper stuck to a flat block of wood to fine-tune the fit (see **photo J**). If everything prior to this has been done with care, there will be only minor adjustments.

5. Label the wedges so you can return them to their respective tenons later.

## Fitting the middle shelves and cutting the biscuit slots

The four center shelves are attached to the sides with loose (unglued) biscuits. These aren't the easiest biscuit joints to cut because of the 3-degree angle of the sides.

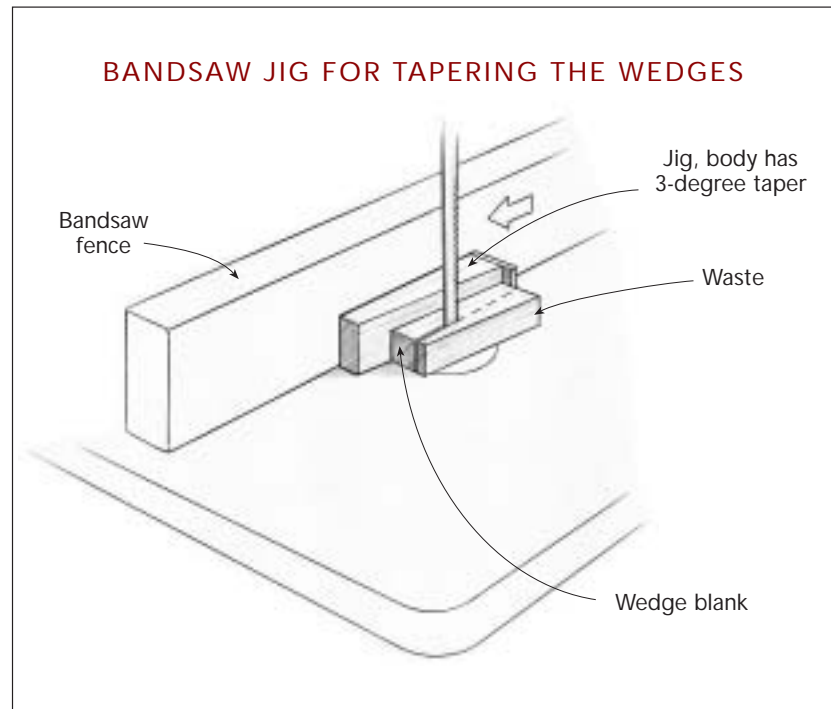

**Photo J:** Sand the tapered faces of the wedges until they all sit at the same height.

## BISCUIT SLOT CUTS FOR MIDDLE SHELVES

### CUTTING SLOTS IN THE SHELF ENDS

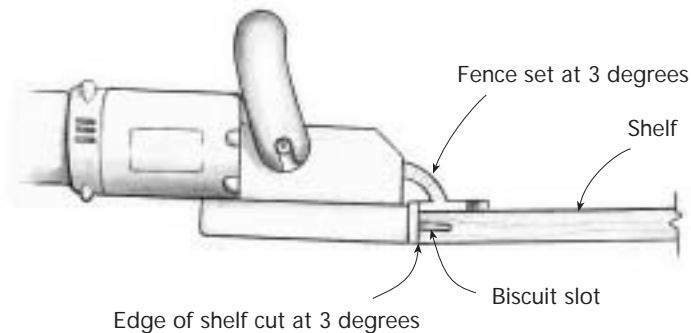

### CUTTING SLOTS IN THE FACES OF THE SIDES

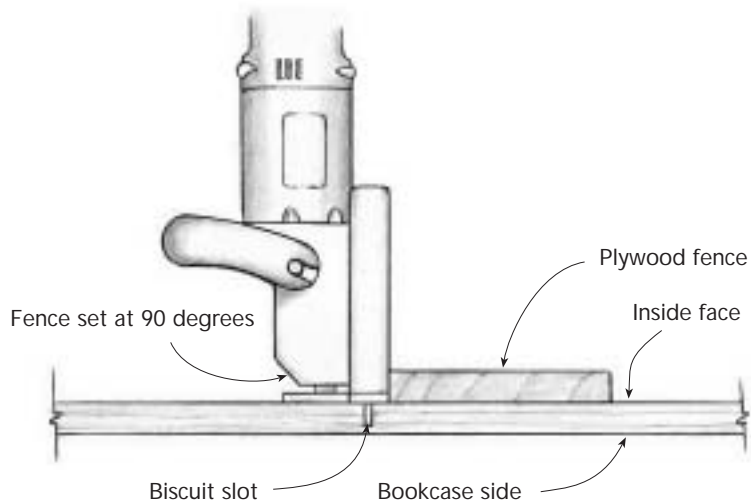

## HOW FAR SHOULD A WEDGE WEDGE?

The wedges on my bookcase drop farther down into their tenons than do the ones on David Fay's case. I made my wedges a little smaller so they'd go deeper, with the idea that they'd seat better. And since this piece can come apart, I thought this was important. I'm not sure if it makes any difference, but it seemed to me that it would. On the downside, I think the higher wedges look a little bit better. So there you go: Life is full of uncertainty and compromise.

1. Assemble the case, install the wedges, and make sure everything is tight.
2. Measure up from the bottom shelf, marking the location of the top of each shelf on both sides of the case.
3. Measure horizontally across the bookcase face with a straightedge and connect these marks. This gives you the width of each shelf (on the top face).
4. Starting with shelf blanks slightly oversized in width and length, crosscut one edge of each on your table saw using the miter gauge set at 90 degrees and the blade tilted to 3 degrees.
5. Creep up on the finished width bit by bit, checking the fit on the case after each cut. Each shelf should fit tight but not bulge the sides or affect the fit of the other shelves.
6. Rip the front edges of the shelves at 3 degrees as well, sizing them  $\frac{1}{8}$  in. narrower than the depth of the case at each shelf location. When installed, the shelves will sit flush with the back and be recessed  $\frac{1}{8}$  in. from the front of the case.

7. Cut biscuit slots in the edges of the shelves, two to an edge. Reference these slots from the top of the shelves with the fence of your biscuit joiner set at 3 degrees (see “Biscuit Slot Cuts for Middle Shelves”).
8. Knock down the bookcase before you cut the biscuit slots in the sides.
9. Draw layout lines across the sides at 90 degrees to the back, starting from the marks that indicate where the tops of the shelves intersect the sides.
10. Lay a piece of plywood along these lines to act as a fence for the biscuit joiner.
11. Cut the biscuit slots in the sides, positioning the joiner against the fence and plunging it in at 90 degrees to the side.

## **FINISHING AND FINAL ASSEMBLY**

### **Rounding the edges**

1. When you complete all the parts, do a final check for fit, fuss with anything that may still be bugging you, and disassemble the bookcase.
2. Work all the edges of the mortises and the holes for the wedges with a file to make the piece look soft and rounded. Round them until they have about a 1/8-in. radius on their edges.
3. Slightly round all the edges of the tenons, wedges, shelves, and sides with sandpaper to the same 1/8-in. radius.
4. Sand everything to 180 grit.

### **Applying the finish**

At David Fay's suggestion I finished the piece with several coats of Formby's low-gloss tung oil. I felt an oil finish was important for a knockdown piece. Frequent assembly and disassembly would easily damage a harder, lacquered finish, and the wedges would, in all likelihood, scratch the finish around them when taken in and out. Oil finishes wear in



**Photo K:** The entire bookcase knocks down into a small pile of flat, small pieces—very handy for transportation.

these ways much better than lacquer finishes and are easily repaired when they dry out or become worn.

With this bookcase, final assembly is, frankly, optional. As a knockdown bookcase, it goes together and comes apart easily. And after you test-fit everything and finish all the pieces, the first thing you may want to do is knock it down to take it somewhere (see **photo K**).