

NEW 'I CAN DO THAT' COLUMN: SIMPLE TOOLS, SEXY PROJECTS
SPECIAL BONUS SECTION: THE INs AND OUTs OF DRAWER SLIDES & HINGES

JUNE 2006
ISSUE #155

POPULAR Woodworking

Learn How. Discover Why. Build Better.

AUTHENTIC SHAKER CABINET

Easy to Build
With Poplar,
Nails & Paint

New Rules for New TVs

Entertainment Centers
Just Got Much Easier

PLUS

- The 2 Best Trim Routers
- 9 Easy Workbench Upgrades
- Turn a Mirror With Dale Nish



fw

F+W PUBLICATIONS, INC.

U.S. \$5.99
CANADA \$7.99



06

Display until May 29, 2006



Grizzly Industrial®

PURVEYORS OF FINE MACHINERY®

THE ULTIMATE 10" CONTRACTOR-STYLE TABLE SAWS W/CAST IRON WINGS & TABLE

- Motor: 2 HP, 110V/220V, single-phase
- Precision ground cast iron table size: 27" x 39⁵/₈" w/wings
- Shop Fox® Alumina-Classic™ Fence
- Arbor: 5/8"
- Rip capacity: 30"
- Cutting capacity: 3¹/₈" @ 90°, 2¹/₈" @ 45°
- Approx. shipping weight: 298 lbs.



RIGHT-TILT
G0444Z ONLY \$575⁰⁰

SERIES

LEFT-TILT
G0576 ONLY \$615⁰⁰

\$85 ANYWHERE IN LOWER 48 STATES

10" LEFT TILTING SUPER HEAVY-DUTY TABLE SAW

- Motor: 3 HP, 220V, single-phase
- Precision ground cast iron table w/ 2 cast iron extension wings
- Table size w/ wings attached: 27" x 40¹/₈"
- Arbor: 5/8" (accepts dado blades up to 1³/₁₆")
- Cutting capacity: 8" L & 26" R of blade
- Max. depth of cut: 3" @ 90°, 2¹/₈" @ 45°
- Approx. shipping weight: 465 lbs.



INCLUDES SHOP FOX® CLASSIC FENCE

G1023SL ONLY \$975⁰⁰

\$85 ANYWHERE IN LOWER 48 STATES

10" LEFT TILTING SAW W/ 7' RAILS & EXTENSION TABLE

- Motor: 3 HP, 220V, single-phase, 3450 RPM
- Precision ground cast iron table
- Extension table size: 27" x 44"
- Arbor: 5/8" (accepts dado blades up to 1³/₁₆")
- Cutting capacity: 8" left, 54" right
- Max. depth of cut: 3" @ 90°, 2¹/₈" @ 45°
- Approx. shipping weight: 540 lbs.



INCLUDES SHOP FOX® CLASSIC FENCE

G1023SLX ONLY \$1250⁰⁰

\$155 ANYWHERE IN LOWER 48 STATES

WOOD MAGAZINE TOP VALUE APPROVED 2008

6" JOINTER

- Motor: 1 HP, 110V, single-phase
- Table size: 6" x 46"
- Max. depth of cut: 1/8"
- Max. rabbeting capacity: 1/2"
- Cutterhead knives: 3
- Cutterhead dia.: 2 1/2"
- Cutterhead speed: 4800 RPM
- Cuts per minute: 14,400
- Cast iron fence
- Approx. shipping weight: 270 lbs.



New!
BUILT-IN "KICK STAND" MOBILE BASE!

INCLUDES A FREE PAIR OF SAFETY PUSH BLOCKS

INTRODUCTORY PRICE!

G0452 ONLY \$325⁰⁰

\$65 ANYWHERE IN LOWER 48 STATES

8" X 75" JOINTERS

- Motor: 2 HP, 110V/220V, single-phase, TEFC, 3450 RPM
- Precision ground cast iron table
- Knives: 4 HSS, 8" x 3/4" x 1/8" (G0586)
- Cutterhead speed: 5500 RPM
- Cutterhead diameter: 3"
- Max. depth of cut: 1/8"
- Max. rabbeting depth: 1/2"
- Cuts per minute: 22,000 (G0586)
- Approx. shipping weight: 558 lbs.



New!

INCLUDES FREE PAIR OF SAFETY PUSH BLOCKS

INTRODUCTORY PRICE!

4 BLADE CUTTERHEAD
G0586 ONLY \$655⁰⁰

SPIRAL CUTTERHEAD
G0593 ONLY \$995⁰⁰

\$155 ANYWHERE IN LOWER 48 STATES

MADE IN ISO 9001 FACTORY

8" X 76" JOINTER

- Motor: 3 HP, 220V, single phase, TEFC, 3450 RPM
- Table size: 8" x 76⁵/₁₆" • Infeed table size: 8" x 43³/₈"
- Cutterhead knives: 4 HSS, 8" x 3/4" x 1/8"
- Cutterhead speed: 4900 RPM • Cuts / minute: 19,600
- Cutterhead diameter: 3³/₁₆"
- Max. depth of cut: 1/8"
- Max. rabbeting depth: 1/2"
- Approx. shipping weight: 461 lbs.



INCLUDES CAST IRON FENCE

PARALLELOGRAM TABLE ADJUSTMENT SYSTEM!

New!

INTRODUCTORY PRICE!

G0490 ONLY \$750⁰⁰

\$85 ANYWHERE IN LOWER 48 STATES

15" PLANER

- Motor: 3 HP, 220V, single-phase
- Precision ground cast iron table size: 15" x 20"
- Max. cutting height: 8"
- Min. stock thickness: 3/16"
- Min. stock length: 12"
- Max. cutting depth: 1/8"
- Feed rate: 16 FPM & 30 FPM
- Cutterhead diameter: 3"
- Number of knives: 3
- Cutterhead speed: 5000 RPM
- Approx. shipping weight: 661 lbs.



New!
BUILT-IN "KICK STAND" MOBILE BASE!

INTRODUCTORY PRICE!

G0453 ONLY \$775⁰⁰

\$155 ANYWHERE IN LOWER 48 STATES

OSCILLATING SPINDLE / 12" DISC SANDER

- Motor: 1 HP, 110V, single-phase, TEFC
- Cast iron tables tilt to 45°
- Oscillating sander table: 14¹/₂" square
- Disc sander table: 17¹/₂" x 10"
- Spindle sizes: 1/4", 5/8", 1 1/2" & 2"
- Spindle speed: 1725 RPM
- Stroke length: 1"
- Approx. shipping weight: 180 lbs.



MADE IN ISO 9001 FACTORY!

FANTASTIC PRICE!

G0529 ONLY \$450⁰⁰

\$65 ANYWHERE IN LOWER 48 STATES

12" BABY DRUM SANDER

- Sanding motor: 1 1/2 HP, 110/220V, single-phase
- Conveyor motor: 1/10 HP, 110V, single-phase, variable speed 0-15 FPM
- Drum speed: 2300 FPM
- Max. stock size: 12" w x 3 3/4"
- Min. stock length: 8"
- Drum size: 4"
- Belt: 3" hook & loop
- Approx. shipping weight: 199 lbs.



New!

INDUSTRIAL-DUTY CONVEYOR BELT & SIDE HANDLES FOR PORTABILITY

INTRODUCTORY PRICE!

G0459 ONLY \$425⁰⁰

\$65 ANYWHERE IN LOWER 48 STATES

7710R

CUSTOMER SERVICE: 570-546-9663 FAX: 1-800-438-5901

MEDIA CODE
POP0606

1-800-523-4777





- A MILLION SQUARE FEET PACKED TO THE RAFTERS WITH MACHINERY & TOOLS
- 2 OVERSEAS QUALITY CONTROL OFFICES STAFFED WITH QUALIFIED GRIZZLY ENGINEERS
- HUGE PARTS FACILITY WITH OVER 1 MILLION PARTS IN STOCK AT ALL TIMES
- TRAINED SERVICE TECHNICIANS AT ALL 3 LOCATIONS
- MOST ORDERS SHIPPED THE SAME DAY
- 24 HOUR ORDERING BY PHONE OR ONLINE

FREE
2006 GRIZZLY CATALOG
604 COLOR PAGES OF
MACHINES, TOOLS &
ACCESSORIES!

NO DEALERS • NO MIDDLEMEN • BUY DIRECT & SAVE!



14" BANDSAW

- Motor: 3/4 HP, 110V/220V, single-phase, TEFC
- Precision ground cast iron table
- Table size: 14" x 14"
- Table tilt: 45° right, 15° left
- Cutting capacity/throat: 13 1/2"
- Max. cutting height: 6"
- Blade size: 92 1/2" to 93 1/2" (1/8" to 3/4" wide)
- Blade speed: 3000 FPM
- 4" dust port
- Approx. shipping weight: 163 lbs.

MADE IN ISO 9001 FACTORY!

INCLUDES QUICK BLADE RELEASE SYSTEM, 3/8" BLADE, FENCE & MITER GAUGE

G0580 ONLY \$325⁰⁰

\$65^{Shipping} ANYWHERE IN LOWER 48 STATES



THE ULTIMATE 14" BANDSAW

- Motor: 1 HP, 110V/220V, single-phase, TEFC
- Precision ground cast iron table
- Deluxe extruded aluminum fence
- Cutting capacity/throat: 13 1/2"
- Max. cutting height: 6"
- Blade size: 92 1/2" - 93 1/2" long (1/8" - 3/4" wide)
- 2 blade speeds: 1500 & 3200 FPM
- Approx. shipping weight: 198 lbs.



MADE IN ISO 9001 FACTORY!

INCLUDES FENCE, MITER GAUGE, 3/8" BLADE & QUICK BLADE RELEASE SYSTEM

G0555 ONLY \$425⁰⁰

\$65^{Shipping} ANYWHERE IN LOWER 48 STATES



17" HEAVY-DUTY BANDSAW

- Motor: 2 HP, 110V/220V, single-phase, TEFC, 1725 RPM
- Precision ground cast iron table
- Table size: 17" x 17" x 1 1/2"
- Max. cutting height: 12"
- Blade length: 131 1/2"
- Blade sizes: 1/8" - 1"
- Blade speeds: 1600 & 3300 FPM
- Dust port: (2) 4"
- Approx. shipping weight: 342 lbs.

MADE IN ISO 9001 FACTORY!

INCLUDES 1/2" BLADE, FENCE & HEAVY-DUTY MITER GAUGE

G0513 ONLY \$795⁰⁰

\$85^{Shipping} ANYWHERE IN LOWER 48 STATES

20" PLANER

- Motor: 5 HP, 220V, single-phase
- Max. cutting width: 20"
- Max. cutting height: 8"
- Min. stock thickness: 3/16"
- Min. stock length: 7.5"
- Max. cutting depth: 1/8"
- Feed rate: 16 FPM & 20 FPM
- Cutterhead diameter: 3 1/8"
- Number of knives: 4
- Cutterhead speed: 5000 RPM
- Table size: 20" x 25 3/4" (20" x 55 3/8" w/ extension)
- Approx. shipping weight: 935 lbs.



INTRODUCTORY PRICE!

G0454 ONLY \$1175⁰⁰

\$165^{Shipping} ANYWHERE IN LOWER 48 STATES

1 1/2 HP SHAPER

- Motor: 1 1/2 HP, 110V/220V, single-phase
- Precision ground cast iron table
- Table size: 20 1/4" x 18"
- Spindle travel: 3"
- 2 interchangeable spindles: 1/2" & 3/4"
- Spindle openings on table: 1 1/4", 3 1/2" & 5"
- Spindle speeds: 7000 & 10,000 RPM
- Max. cutter diameter: 5"
- Approx. shipping weight: 221 lbs.

SHOWN W/ OPTIONAL 61706 WING



INCLUDES MITER GAUGE & FENCE WITH SAFETY GUARDS & HOLD-DOWN SPRINGS

G1035 ONLY \$515⁰⁰

\$65^{Shipping} ANYWHERE IN LOWER 48 STATES

3 HP SHAPER

INCLUDES MITER GAUGE & FENCE WITH HOLD-DOWN SPRINGS

- Motor: 3 HP, 220V, single-phase w/ reversing switch
- Precision ground cast iron table
- Table size w/ standard wing attached: 30 1/2" x 28 1/4"
- 3 interchangeable spindles: 1/2", 3/4" & 1"
- Spindle travel: 3"
- Spindle openings on table: 1 3/8", 2 3/4", 4 & 5 1/2"
- Spindle speeds: 7000 & 10,000 RPM
- Approx. shipping weight: 357 lbs

MAGNETIC SWITCH

G1026 ONLY \$950⁰⁰

\$85^{Shipping} ANYWHERE IN LOWER 48 STATES

24" VARIABLE SPEED DRUM SANDER

- Drum motor: 5 HP, 220V, single-phase
- Conveyor motor: 1/4 HP
- Conveyor speed: variable, 0 - 20 FPM
- Max. stock thickness: 4 1/4"
- Sandpaper: 3" hook & loop
- Control panel with amp load meter
- Dust ports: (2) 4"
- Approx. shipping weight: 489 lbs



INCLUDES A HEAVY-DUTY RUBBER CONVEYOR BELT!



G1066Z ONLY \$1795⁰⁰

\$85^{Shipping} ANYWHERE IN LOWER 48 STATES

2 HP CYCLONE DUST COLLECTOR

- Motor: TEFC Class "F", 2 HP, 220V, single-phase
- Amps: 12.5
- Cycle/RPM: 60 Hertz/ 3450 RPM
- Intake hole size: 7"
- Impeller: 13 1/2" steel, riveted
- Suction capacity: 1354 CFM @ 2.5" SP
- Static pressure: 10.4"
- Filtration: 0.2-2 micron, 99.9% efficiency
- Filter surface area: 86 sq. ft.
- Collection Drum: Steel, 35 gallons
- Approx. shipping weight: 315 lbs.



G0440 ONLY \$745⁰⁰

\$85^{Shipping} ANYWHERE IN LOWER 48 STATES

3 HP CYCLONE DUST COLLECTOR

- Motor: TEFC Class "F", 3 HP, 220V, single-phase
- Amps: 19.5
- Cycle/RPM: 60 Hertz/ 3450 RPM
- Intake hole size: 8"
- Impeller: 15" steel, riveted
- Suction capacity: 1654 CFM @ 2.0" SP
- Static pressure: 14.2"
- Filtration: 0.2-2 micron, 99.9% efficiency
- Filter surface area: 108 sq. ft.
- Collection Drum: Steel, 55 gallons
- Approx. shipping weight: 396 lbs.



G0441 ONLY \$1195⁰⁰

\$85^{Shipping} ANYWHERE IN LOWER 48 STATES



OVER 12,000 PRODUCTS ONLINE!

grizzly.com





1000

This year marks a century of PORTER-CABLE® helping woodworkers turn their imagination into reality. Over that time, we've had quite a few amazing creations of our own. Check out the impact our history has had on woodworking shops around the world at porter-cable.com/centennial.



contents

7 POPULAR Woodworking

Learn How • Discover Why • Build Better

IN EVERY ISSUE



26

20 Wedged Frame Clamping

TRICKS OF THE TRADE

The power of wedges allow you to clamp any size or shape of mitered frame. Plus, a simple trick for accurate handplaning, new uses for your biscuit joiner and a tricky way to separate wood plugs.

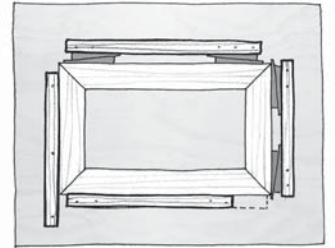

20

26 Minas Tirith Shutters

I CAN DO THAT

Our newest column shows you how to make nice furniture using simple tools and common materials available at the home center. In this issue: Build bi-fold shutters spotted in the background of “The Lord of the Rings.”

28 Ridgid’s R2930 Router

TOOL TEST

Ridgid’s first router is a shining success. Plus, new custom backsaws from Wenzloff & Sons, Grizzly’s compact drum sander and a near-perfect drill press table.



28

32 Charles Plumley Inventory

ARTS & MYSTERIES

This 18th-century Philadelphia inventory reveals shop secrets about early American woodworking and tests our assumption of how they did things “in the old days.”
by Adam Cherubini



32

36 Complementary Curves

POWER-TOOL JOINERY

Discover how to use tricky templates and your router to join wood along both simple and complex curves.
by Bill Hylton

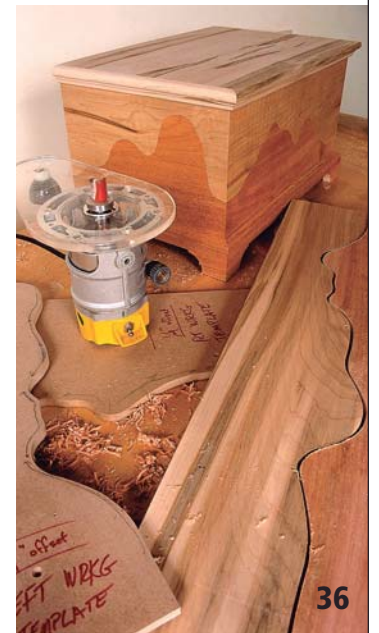

36

81 From Wood Chunk to Chuck

AT THE LATHE

Proper wood prep, sorting and storage is key to quickly finding the wood you want when it comes time to turn.
by Judy Ditmer



81

84 Craftsmanship Done Safely

GREAT WOODSHOPS

At Kelly Mehler’s School of Woodworking, safety is a key lesson – coupled with expert woodworking instruction.

Number 155, June 2006. *Popular Woodworking* (ISSN 0884-8823; USPS 752-250) is published 7 times a year in February, April, June, August, October, November and December by F+W Publications Inc. Editorial and advertising offices are located at 4700 E. Galbraith Road, Cincinnati, Ohio 45236; tel.: 513-531-2222. Unsolicited manuscripts, photographs and artwork should include ample postage on a self-addressed, stamped envelope (SASE); otherwise they will not be returned. Subscription rates: A year’s subscription (7 issues) is \$19.96; outside of U.S. add \$7/year • Canada Publications Mail Agreement No. 40025316. Canadian return address: 2744 Edna St., Windsor, ON N8Y 1V2 • Copyright 2006 by *Popular Woodworking*. Periodicals postage paid at Cincinnati, Ohio, and additional mailing offices. Postmaster: Send all address changes to *Popular Woodworking*, P.O. Box 420235, Palm Coast, FL 32142-0235 Canada GST Reg. #R122594716 • Produced and printed in the U.S.A.



YOUR HEADQUARTERS FOR DELTA® PROFESSIONAL-GRADE WOODWORKING MACHINERY



LEFT-TILT BLADE

45°

CAST IRON WINGS AND TABLE WITH T-SLOTS

BIESEMEYER COMMERCIAL
FENCE SYSTEM

INDUSTRIAL TRUNNION SYSTEM
WITH UPFRONT CONTROLS

HEAVY DUTY STAND WITH
VIBRATION OSCILLATING FEET

HEAVY DUTY INDUSTRIAL
1-1/2 HP INDUCTION MOTOR

INTEGRATED
MOBILE BASE



THE LEFT-TILT CONTRACTOR'S SAW. PERFECTED.

It should come as no surprise that DELTA® took the time to introduce left-tilt Contractor's Saws the right way. After all, DELTA invented the Contractor's Saw® category. And once you try a DELTA, there's no going back. Besides a left-tilt blade and powerful 1-1/2 HP motor, you also have a choice of three fence systems including a BIESEMEYER® or DELTA® UNIFENCE®. You even get maximum mobility with a newly designed base. Plus, its new collection tray captures 80-90% of the dust. So find perfection. Visit deltamachinery.com/contractor for more details, or to join our DELTA Owners Group.

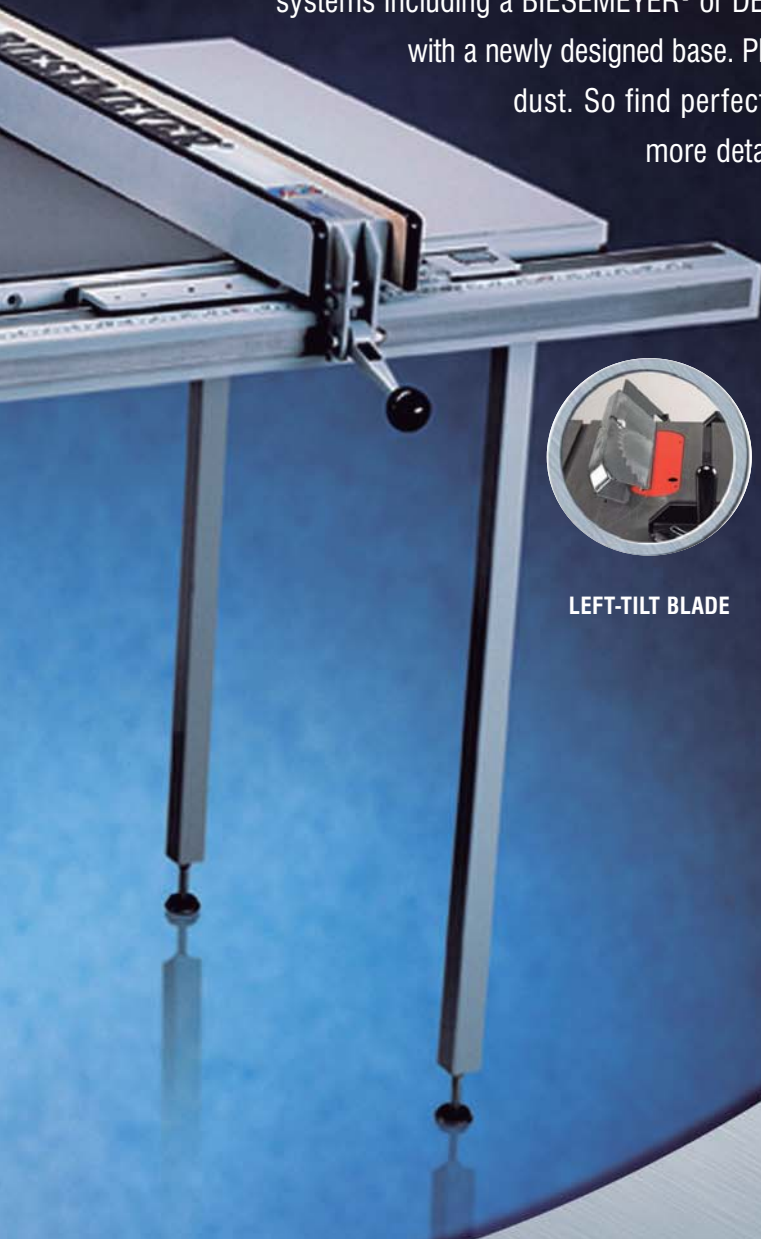

LEFT-TILT BLADE



INTEGRATED
MOBILE BASE

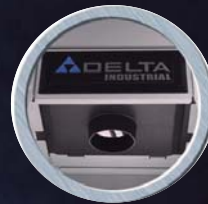

DUST PORT

 **DELTA®**
YOUR ACHIEVEMENT. OUR TOOLS.



ON THE COVER

Go “behind the ropes” with Kerry Pierce at Pleasant Hill for a close-up look at this classic Shaker hanging cupboard. Plus, a revelation about Shaker workmanship that may come as a big surprise – nails, and lots of them.

Cover photo by Al Parrish

DEPARTMENTS

10 **Out on a Limb**
A new column for new woodworkers

12 **Letters**
Mail from readers

16 **Q&A**
Flattening unruly panels, discovering hand tool shops and more

90 **Flexner on Finishing**
Understanding Stains

96 **Out of the Woodwork**
Woodworking Can Be a Blast
by Sam Sherrill

PROJECTS, TOOLS AND TECHNIQUES

40 **Workholding Strategies**

Get a grip on your hand-tool work with inexpensive stops, clamps and jigs – and of course, a sturdy bench.
by Lonnie Bird

45 **Casework Construction: Cabinet Hardware**

WOODWORKING ESSENTIALS

Proper hardware selection is key to a functional and attractive finished casework project.

53 **Pocket Mirrors**

Take a turn at creating these lovely gift mirrors adorned with Russian enamel paintings.
by Dale Nish



56 **Pleasant Hill Shaker Cupboard**

A home center provides common stock to create this Shaker project of uncommon beauty. For the first time ever, the measured drawings of this classic Western Shaker piece are in print.
by Kerry Pierce

62 **Side Sharpening**

Just remember that “wider is better” and you’ll quickly master this freehand sharpening method.
by Harrelson Stanley

66 **Entertaining Designs**

Thinner TVs, smaller components and new forms of media have changed the rules when designing entertainment centers. We show you the new guidelines and the proper steps to follow for your next entertainment center.

70 **Rustic Garden Bench**

Create an ideal resting place for your bucolic backyard setting with a slab of wood and some rugged legs.
by John Wilson

76 **Trim Routers**

These little workhorses are for more than just routing countertop edge profiles. We’ll help you decide which one is best for your woodworking needs and budget.





XTRA LARGE TURBO CHARGED

**IRWIN
QUICK-GRIP**

POWER LOCK TABS



Introducing the QUICK-GRIP® XP – the most powerful, versatile one-handed bar clamp available.

The XP's pistol-grip design, POWER LOCK TABS™ and **i-beam bar** combines the convenience of one-handed clamps with the power of traditional clamps, making glue-ups and holding easier and faster than ever. And with **550 pounds of force**, it's 2x stronger*.

IRWIN
QUICK-GRIP® XP

One-Handed Bar Clamp & Spreader

WWW.IRWIN.COM/XP

THE ONLY CLAMP YOU'LL EVER NEED

CIRCLE NO. 127 ON FREE INFORMATION CARD.

© 2006 IRWIN® Huntersville, NC 28078-1801
*versus other IRWIN one-handed bar clamps



WOODCRAFT[®]
Helping You Make Wood Work[®]

For A Free Catalog Or To Find Your Local Woodcraft Store, Visit www.woodcraft.com Or Call 800-542-9115



**MATCH
IT WITH
MIXOL**[®]

With 32 shades of Mixol Universal Tints, the most extraordinary tinting capabilities are at your fingertips.

Mix with Mixol and you can match anything, anywhere, anytime, any color. Now find Mixols at your local Woodcraft store, visit www.woodcraft.com or call 1-800-542-9115.

Dept: 06PW06R

QUALITY WOODWORKING TOOLS • SUPPLIES • ADVICE[™]

CIRCLE NO. 156 ON FREE INFORMATION CARD.

**POPULAR
Woodworking**[®]

June 2006, Vol. 26, No. 3
popularwoodworking.com
Editorial Offices 513-531-2690

Publisher & Group Editorial Director
Steve Shaney

Editor **Christopher Schwarz**
ext. 1407 • chris.schwarz@fwpubs.com

Art Director **Linda Watts**
ext. 1396 • linda.watts@fwpubs.com

Senior Editor **David Thiel**
ext. 1255 • david.thiel@fwpubs.com

Senior Editor **Robert W. Lang**
ext. 1327 • robert.lang@fwpubs.com

Managing Editor **Megan Fitzpatrick**
ext. 1348 • megan.fitzpatrick@fwpubs.com

Associate Designer **Susan L. Smith**
ext. 1058 • susan.l.smith@fwpubs.com

Project Illustrator **John Hutchinson**

Photographer **Al Parrish**

Contributing Editors

**Adam Cherubini, Nick Engler, Bob Flexner,
Glen Huey, Don McConnell, Troy Sexton**

F+W PUBLICATIONS INC.

David H. Steward, Chairman & CEO
Andrew Levy, SVP, Development & Strategy
Barbara Schmitz, VP, Manufacturing

F+W PUBLICATIONS INC.

MAGAZINE GROUP

William R. Reed, President

Susan Du Bois, VP, Consumer Marketing
Matt Friedersdorf, Director of Business Planning
Deb Westmaas, Group Circulation Director
Mark Fleetwood, Group Circulation Manager
Cristy Malcolm, Newsstand Sales Supervisor

PRODUCTION

Vicki Whitford, Production Manager
Debbie Thomas, Production Coordinator

ADVERTISING

Don Schroder, Advertising Director
331 N. Arch St., Allentown, PA 18104
Tel. 610-821-4425; Fax 610-821-7884
d.schroder@verizon.net

Advertising Production Coordinator
Krista Morel, Tel. 513-531-2690 ext. 1311
krista.morel@fwpubs.com

SUBSCRIPTION SERVICES: Subscription inquiries, orders and address changes can be made at popularwoodworking.com (click on "Customer Service FAQs"). Or by mail: Popular Woodworking, P.O. Box 420235, Palm Coast, FL 32142-0235. Or call toll-free 877-860-9140 or 386-246-3369. Include your address with all inquiries. Allow 6 to 8 weeks for delivery.

NEWSSTAND DISTRIBUTION: Curtis Circulation Co., 730 River Road, New Milford, NJ 07646

ATTENTION RETAILERS:

To carry Popular Woodworking in your store, call 800-894-4656 or write Magazine Retail Sales, P.O. Box 5014, Iola, WI 54945-5014.

Back issues are available. Call 800-258-0929 for pricing or visit popularwoodworking.com. Send check or money order to: Popular Woodworking Back Issues, F+W Publications Products, 700 E. State St., Iola, WI 54990. Please specify publication, month and year.

fw
F+W PUBLICATIONS INC.

HIGH-PERFORMANCE LOW-GRIEF EPOXY

For gluing, sealing, filling, smoothing, laminating, reinforcing, installing hardware, . . .



FREE User Guide

call us 866-376-9948 toll free in US & Canada
or visit www.EpoxyHeads.com

CIRCLE NO. 114 ON FREE INFORMATION CARD.

SAFETY NOTE

Safety is your responsibility. Manufacturers place safety devices on their equipment for a reason. In many photos you see in Popular Woodworking, these have been removed to provide clarity. In some cases we'll use an awkward body position so you can better see what's being demonstrated. Don't copy us. Think about each procedure you're going to perform beforehand.

INNOVATIVE PRODUCTS DESIGNED FOR PRACTICAL USE

WE DESIGN OUR MACHINES TO THE MOST STRINGENT STANDARDS,
TRIPLE CHECK EACH ONE FOR QUALITY ASSURANCE AND
BACK EVERY MACHINE WITH A FULL TWO-YEAR WARRANTY!



2 HP, 10" CONTRACTOR TYPE SAW

This saw is ready to rip with heavy-duty cast iron extension wings & the Shop Fox® Aluma-Classic® Fence.

FEATURES:

- ◆ 2 HP, 110V*/220V, single-phase motor
- ◆ Precision ground cast iron table w/ T-slots
- ◆ Table size w/wings: 39⁵/₈" x 27"
- ◆ Max. depth of cut: 3¹/₈"
- ◆ Ripping capacity: 28"
- ◆ Arbor speed: 4250 RPM
- ◆ Approx. shipping weight: 310 lbs.

W1714



Both Standard & Dado Inserts Are Included

* 110V operation requires purchase of 110V magnetic switch.

14" BANDSAW w/CABINET STAND

We took the most popular bandsaw size and added many features usually found only on larger & more expensive machines.

Includes Blade, Fence & Heavy-Duty Miter Gauge

FEATURES:

- ◆ 1 HP, 110V/220V, single-phase, TEFC motor
- ◆ Table tilt: 45° right, 10° left
- ◆ Max. cutting height: 6" (12" w/ optional ext.)
- ◆ Blade size: 93¹/₂" (1¹/₈" - 3³/₄" wide)
- ◆ Blade speeds: 1500 & 3200 RPM
- ◆ Quick release blade tensioning
- ◆ Ball bearing blade guides
- ◆ Approx. shipping weight: 256 lbs.

W1706



3/4 HP MORTISING MACHINE

We designed this Mortising Machine to address all the frustrations found in other models on the market.

Unique swiveling head assembly!

FEATURES:

- ◆ 3/4 HP, single-phase motor
- ◆ Adjustable depth stop rod
- ◆ Gas spring return
- ◆ Double support columns
- ◆ Jacobs® taper #2 spindle
- ◆ Heavy-duty cast iron construction
- ◆ Micro adjustable fence
- ◆ Approx. shipping weight: 94 lbs.

W1671



1 HP SHAPER with ROUTER SPINDLE

This truly versatile machine combines the best of all worlds – a rock-solid router table, a powerful shaper & a split adjustment fence for easy edge jointing & profiling!

FEATURES:

- ◆ 1 HP, 110V single-phase reversible motor
- ◆ Precision ground cast iron table: 24¹/₄" x 19" w/ 3/4" miter slot
- ◆ Spindle: 3" x 1/2" diameter
- ◆ Spindle speed: 13,200 RPM
- ◆ Spindle travel: 7/8"
- ◆ Maximum cutter height: 2¹/₂"
- ◆ Accepts 1/4" and 1/2" router bit spindles
- ◆ Approx. shipping weight: 200 lbs.

Split Adjustment Fence

W1701



15" PLANER with CABINET STAND

Get silky smooth cuts with the spiral cutterheads on this most popular sized heavy-duty planer.

FEATURES: Spiral Cutterhead!

- ◆ 3 HP, 220V, single-phase motor
- ◆ Mirror ground cast iron tables
- ◆ Feed rate: 16 & 20 FPM
- ◆ Maximum thickness: 6"
- ◆ Cutterhead diameter: 3"
- ◆ Cutterhead speed: 5000 RPM
- ◆ Handwheel height adjustment
- ◆ 4 rigid steel support columns
- ◆ Approx. shipping weight: 430 lbs.

W1724



MINI PLANER/MOULDER

Open sided Mini Planer/Moulder allows plenty of flexibility for profiling mouldings and panels.

FEATURES:

- ◆ 2 HP, 220V, single-phase motor
- ◆ Cutterhead speed: 7000 RPM
- ◆ Feed rate: 15 FPM
- ◆ Max. profile depth: 3/4"
- ◆ Max. profile width: 6³/₄"
- ◆ Planing width: 7"
- ◆ Min. stock length: 9"
- ◆ Min. stock thickness: 1/4"
- ◆ Max. stock thickness: 8"
- ◆ Approx. shipping weight: 200 lbs.

W1693

Full selection of Moulding Knives Also Available



A New Column for New Woodworkers

Most readers assume that we are awash in tools here at *Popular Woodworking*, but that's not quite right. In actuality, we are obscenely awash in tools.

I just walked through our shop and counted 15 cordless drills scattered on the four active workbenches – and we're not even running a cordless drill test right now. You name it, we probably have one, or have seen one, or have worked with one recently.

Though this might sound like heaven to you, we all worry sometimes that it colors our view of the craft. Because we have many specialized tools, we end up using them in the projects we build and showing them in our step photos and extolling their virtues.

I think this is natural – a dedicated hollow-chisel mortiser is going to make mortises better and faster and easier than a drill press and a chisel. But not everyone can afford a hollow-chisel mortiser, or even a table saw, power planer or a smoothing plane at first. Good tools are expensive, and it takes a while for the beginning woodworker to gather enough tools to actually build something of substance.

Or does it?

For the last year or so, we've been plotting a different kind of column for this magazine. We're calling it "I Can Do That" and its first installment is on page 26 of this issue.

In every issue, this column will offer plans for a project that can be built with a small set of power and hand tools – stuff that a beginning woodworker likely has, such as a jigsaw, block plane, miter saw and hand drill.

All of the materials for the projects will come right off the shelves of a home-center store. There will be no specialty lumber to find or oddball hardware to search for.

We want the projects themselves to appeal to woodworkers of all skills, from the beginner to the seasoned craftsman. You're not going to see any chunky, cheesy 2 x 4 furniture (though you might see some nice stuff made using 2x4s, if you catch my drift). Nice furniture doesn't have to be difficult to build.

And here's the last interesting wrinkle to the column – we're not going to print step photos of the construction process. I know this sounds insane for a column designed to appeal to the beginner. But here's the wrinkle: We're going to offer a free online manual in PDF format for this column that will show you how we perform each operation (ripping, cross-cutting, curve-cutting and so on) with a limited kit of tools.

We'll update the "I Can Do That" manual (available at ICanDoThatExtras.com) as we add new techniques

with each installment. Having an online manual will allow a beginner to dive into this column at any time, and it keeps us from cluttering our pages with photo after photo of the same basic operations in every issue of your magazine.

We think you'll like this approach, and we have some ideas for how to make it even more interesting. I'm trying to talk Adam Cherubini, our "Arts & Mysteries" hand-tool purist, into producing a separate online manual that will show you how to build these projects armed only with hand tools.

Let us know what you think. **PW**

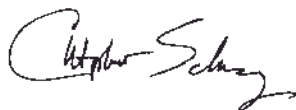

Christopher Schwarz
Editor

CONTRIBUTORS

HARRELSON STANLEY

Harrelson Stanley is many things including entrepreneur, Japanese tool expert, craftsman, teacher and video host. But most important, he is a fanatic about sharpening.



The words "sharp enough" aren't in his vocabulary. A graduate of the North Bennett Street School and an apprentice in Japan for 11 years (studying traditional crafts), Harrelson

now makes his living sharing his passion for sharpening and selling Japanese tools and waterstones (he brought Shapton stones to the United States). In this issue Harrelson shows a freehand sharpening technique he teaches at woodworking shows that he calls "side sharpening." It begins on page 62.

SAM SHERRILL

When a tree falls in the Cincinnati area, there's a fair chance that the phone will ring at Sam Sherrill's house. Since the 1990s, this economics professor and amateur



woodworker has been harvesting thousands and thousands of board feet of lumber from downed urban trees. His efforts led to the publishing of a book, "Harvesting Urban

Timber" (Linden), an appearance on "The New Yankee Workshop" and a web site that connects urban property owners with saw-mill operators (harvestingurbantimber.com). And when he has a spare moment, he makes nice furniture. Read about his most unusual urban forestry project in our "Out of the Woodwork" column on page 96.

Our Privacy Promise to You

We make portions of our customer list available to carefully screened companies that offer products and services we believe you may enjoy. If you do not want to receive offers and/or information, please let us know by contacting us at:

List Manager, F+W Publications
4700 E. Galbraith Road, Cincinnati, OH 45236

CENTER for FURNITURE CRAFTSMANSHIP

Teaching Creative Excellence

WORKSHOPS

TWELVE-WEEK INTENSIVES

NINE-MONTH COMPREHENSIVE



www.woodscool.org ■ 207-594-5611 ■ Rockport, Maine

CIRCLE NO. 109 ON FREE INFORMATION CARD.

Forrest Blades

Serious woodworkers count on American-made Forrest saw blades for smooth, quiet cuts, everytime...without splintering scratching or tearouts. No matter what your application, Forrest blades are simply the best money can buy. That's why discriminating craftsmen prefer them!

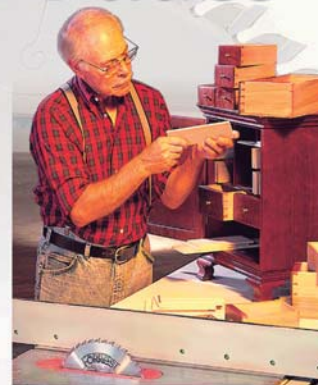

"[Your blades] cut true, with no vibration. I can say with confidence that Forrest blades are the best."
Carl Stude - Burbank, CA

Ask for Forrest blades at a fine dealer or retailer, order online, or call the factory directly. Your satisfaction is guaranteed...or your money back!

Our Most Popular Saw Blades:

Woodworker II - This award-winning all-purpose blade is the finest of its type.

ChopMaster - Produces perfect miters with smooth edges ...and no bottom splinters.

FORREST

The First Choice of Serious Woodworkers Since 1946

www.stores.yahoo.com/forrestman
1-800-733-7111
(In NJ, call 973-473-5236)

© 2005 Forrest Manufacturing

Code PW

CIRCLE NO. 119 ON FREE INFORMATION CARD.

RAZOR SAW
It cuts FASTER! EASIER! MORE ACCURATELY!



Order now, only \$25.95 post paid!

Craftsmen around the world have discovered the secret of better quality work. The Razor Saw cuts by pulling and will give a cleaner, more accurate cut in half the time.

Purchase a RAZOR SAW now and we will include our 102 page catalog of the world's finest woodworking tools. Or send \$2.00 for a two year subscription to our Catalog.

The Best handsaw for ALL woodworkers!
www.japanwoodworker.com
Dept P1

THE JAPAN WOODWORKER

1731 Clement Ave. • Alameda, CA 94501 • 1-800-537-7820

CIRCLE NO. 128 ON FREE INFORMATION CARD.



THE PINNER.

engineered to perfection

The #1 recommended micro-pinner by the professional & do-it-yourselfer woodworking communities.

P635 - 23 Gauge 1-3/8" Headless Pinner



Changing ideas into solutions.

GREX introduces the only micro-pinner featuring a self-adjust magazine and fastener range from 3/8" up to 1-3/8". Designed for detail woodworking, the pins leave practically invisible holes. Though lightweight, compact and easily maneuverable, the tool contains a powerful motor that can penetrate pins through the hardest materials.

888-4GREXCO info@grexusa.com www.grexusa.com

power reliability quality pride

CIRCLE NO. 123 ON FREE INFORMATION CARD.

Introducing the

K3 Kreg Jig®



The Fastest way to Join Wood!

INTERCHANGEABLE
2 TOOLS IN 1
DRILL GUIDE DESIGN

PATENT PENDING

Innovative NEW features...

- Interchangeable Drill Guide Block
- Front Side Clamping
- Dust Collection
- Unlimited Material Thickness Settings
- Material Support Stop

Kreg Jig® Master System
ITEM# K3MS

Visit us online at www.kregtool.com
for an interactive tour of the K3 Kreg Jig®



800-447-8638 • www.kregtool.com

CIRCLE NO. 132 ON FREE INFORMATION CARD.

Sears Left-tilt Table Saw Hails from 1930s



“THE RULES HAVE CHANGED!”

www.bobsrule.com

CIRCLE NO. 108 ON FREE INFORMATION CARD.

Lowest Prices Guaranteed!

FREE CATALOG!

Your Source For Essential, Unique, & Hard To Find Tools!

800-345-2396
hartvilletool.com

CIRCLE NO. 125 ON FREE INFORMATION CARD.

Adams Wood Products, Inc.
FURNITURE COMPONENTS
STOCK ITEMS • NO MINIMUM
CUSTOM COMPONENTS

FEATURED ITEMS

NEW!

FREE COLOR CATALOG

A0923 Fluted
A0924 Reeded
A0914-35-35 Island Leg
AFR26 Queen Anne
A0921-41-35 Island Leg
536 Bun Foot
A0852-5 Finial
552 Bun Foot

Adams Wood Products, Inc.
P.O. Box 728, Dept. PW23
Harristown, TN 37815-0728
Phone 423-587-2942 Fax 423-586-2188
www.adamswoodproducts.com

Made in Tennessee
by American Craftsmen

CIRCLE NO. 100 ON FREE INFORMATION CARD.

In the December 2005 issue I promised to follow-up on when Sears first introduced a table saw that tilted to the left. Several readers wrote and e-mailed about their saws, some of which have been in service since the early 1950s. The earliest reference I could find was from a 1937 Sears tool catalog that featured a left-tilting saw. In the 1932 Sears catalog, the table saws featured tilting tables. Thanks to Brian Kachadurian at Old Wood-Working Machines (owwm.com) for sharing the old catalogs.

— Robert Lang, senior editor



Through Dovetails Could Reflect a Shaker 'Design Opportunity'

In Kerry Pierce's "Shaker Construction Methods" (December 2005, issue #152), he mentions in the "Puzzling Over Why" section that the chest had half-blind dovetails where there normally would have been through dovetails and vice versa. What a great opportunity to poll your readership as to why they think it is constructed this way.

My theory on the odd construction: design opportunity. This is a term I happily stole from one of my mentors, Mike Wallace. A design opportunity is when you make an error that demands that you redesign your work in order to correct your error. Basically, you screwed up and have to figure out a way to fix it so you don't chuck the whole project!

What if our Shaker craftsman cut on the wrong side of his knife mark? He might change the dimensions on the dovetails so the piece could be saved. What if he used an inside measurement instead of an outside measurement on the side panel? He would likely use

a half-blind dovetail now that the panel was too short for a through dovetail. What if this chest was made by an apprentice? The Master would surely insist that the apprentice practice his dovetailing technique. This chest might just be a practice session. I try different woods and joints all the time.

The next time Pierce steps out into the morning air to reflect on the Shakers of 150 years ago, he should recall them as mere mortals. They had to practice and experiment, and I'm sure they had plenty of design opportunities – just like us.

Bill Hook
Weatherford, Texas

Organization Breeds Joint Success

I have owned a Leigh dovetail jig for several years and had yet to use it to make some drawers that have been on the drawing board for quite some time. I have been intimidated all this time. After reading Bill Hylton's "Half-blind Dovetails by Jig" (February 2006, issue #153), I realize the problem has been one of organization not of mechanics. Thanks for an absolutely great article. My project has now been successfully completed and I am now on to bigger and better joints.

Don Burdg
Coos Bay, Oregon

An Alternative to QuickCAD

I read with interest Hank Jacob's question on QuickCAD in the February 2006 *Popular Woodworking*. Days after reading the article about CAD in June 2003 (issue #134), I purchased QuickCAD. It proved to be the best \$50 I spent for our custom furniture and cabinet business. I have used that program six days a week since then.

My brother recently wanted to buy QuickCAD and I was trying to help him find it. I ended up contacting AutoDesk and yes, it was discontinued. What I did find out, though,

continued on page 14

Stop holding your breath.

Breathe easier knowing that HEPA-equipped Festool CT dust extractors eliminate 99.99% of dust, improving safety and efficiency.

Dual HEPA air filters remove 99.99% of all particulate down to .3 microns – an industry-leading performance figure.



Added Systainers make the CT a mobile tool cabinet



Parking brake for stable positioning



Large wheels easily navigate across job sites



Tool-triggered auto-start and variable power



Serious capacity – up to 8.7 gallons (CT 33 E)

CT MOBILE DUST EXTRACTORS

CT 33 E – 8.7 gallon | CT 22 E – 5.8 gallon | CT Mini* – 2.6 gallon

The brilliance of the Festool CT mobile dust extractor is in the details. The standard-equipped, dual HEPA air filters keep floors and lungs dust-free by reducing 99.99% of particulate down to .3 microns. Meanwhile, the powerful CT motor is remarkably quiet, and the auto-start feature turns suction on and off in sync with whichever tool is connected. Large wheels, a parking brake and the ability to add Systainers make the CT an incredible mobile tool cabinet. Contact us or visit your local dealer to learn more about the entire Festool system.

Fasten your tool belts!

FIND YOUR DEALER | www.festoolusa.com/dealers | 888-337-8600



CT 33 E Mobile Dust Extractor

*CT Mini does not come equipped with HEPA filters.

FESTOOL®

Woodpecker Quick-Lift

- **Fastest** Bit Change.
- **Finest** Adjustment.

The new Woodpecker Quick-Lift makes using your router table faster and easier than ever. Use the lift wrench to instantly raise your router to bit change height. Then use the Speed Crank to fine adjust in .001" intervals.

Woodpeckers Inc • woodpeck.com • 1-800-752-0725

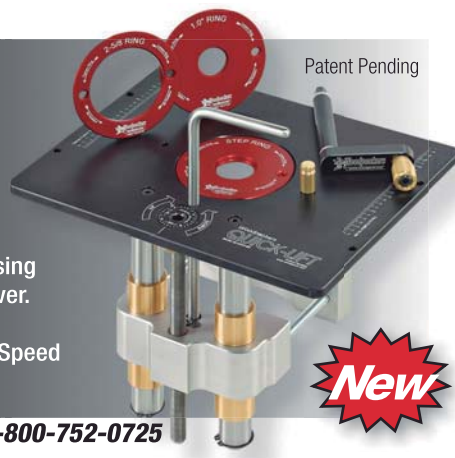

Patent Pending



CIRCLE NO. 158 ON FREE INFORMATION CARD.

AMERICAN MADE. AMERICAN TOUGH.

THE ARROW® T50® STAPLE GUN TACKER.

You won't find any cheap, breakable, plastic parts in this heavy duty staple gun. Made right here in the U.S.A. of 100% steel, this gun is rugged, durable and 100% reliable. An easy squeeze mechanism helps make your job easier too. And it's from the company that's been making staple guns for over 75 years. No wonder it's America's favorite.



THE ALL AMERICAN STAPLE GUN

Available at home centers, lumber yards, hardware stores and wherever fine tools are sold.

Arrow Fastener Co., Inc., 271 Mayhill Street, Saddle Brook, NJ 07663.

Canada: Jardel Distributors, Inc., 6505 Metropolitan Blvd., East, Montreal, Quebec H1P 1X9.

United Kingdom: Arrow Fastener (U.K.) Ltd., Unit 5 ZK Park, 23 Commerce Way, Croydon CRO 4ZS, Surrey.

© 2006 Arrow Fastener Company, Inc.

www.arrowfastener.com

CIRCLE NO. 104 ON FREE INFORMATION CARD.

LETTERS

continued from page 12

for those of you who would like QuickCAD, is that there is a program called AutoSketch that is basically the same, but it can convert 2D drawings to isometric (basic 3D) views (\$130 from Dell: 800-289-3355, dell.com). I use this program for every custom project, and it is a great value for its price. So to Hank, I would say, "buy AutoSketch." The good thing about AutoSketch is that it has a similar working environment to AutoCAD, so if you decide to upgrade in the future, you don't have to spend nearly as much time learning a totally new program from a different company.

Kevin L. Zook

Whitinsville, Massachusetts

Questions About Side Grinding

John Wilson's article "5 Router Plane" (August 2005, issue #150) stirred some heated debate among our readers as to whether his technique of grinding the bevel on the Allen wrench using the side of the grinding wheel was safe or not. OSHA regulations and ANSI standards weren't perfectly clear to us, so we contacted Norton, one of the largest manufacturers of grinding wheels for its position.

Roger E. Cloutier, senior product safety engineer, replied to us stating: "ANSI only allows side grinding on 'applications such as shoulder contour and form grinding where it is recognized that a limited amount of side grinding will be performed.' Type 1 grinding wheels are designed to be used on their outer diameter and not on their sides."

While some might interpret grinding the bevel as "a limited amount" of side grinding, we recommend following Norton's advice and using only the wheel's outer perimeter. **PW**

—Robert Lang, senior editor

WRITE TO US

Popular Woodworking welcomes letters from readers with comments about the magazine or woodworking in general. We try to respond to all correspondence. Published letters may be edited for length or style. All letters become the property of Popular Woodworking. How to send your letter:

- E-mail: popwood@fwpubs.com
- Fax: 513-891-7196
- Mail carrier:
Letters • Popular Woodworking
4700 E. Galbraith Road
Cincinnati, OH 45236

The Big Easy. Easy Dovetails. Easy Mortise & Tenons. Easy. Period.



NEW!

www.leighjigs.com
800-663-8932

**FREE DVD!
FREE CATALOG!**

LEIGH
Joining Tradition With Today



WOODCRAFT
Helping You Make Wood Work®

FREE Tool Catalog



Your Best Work Starts With Us...

with over 8,000 of the finest woodworking tools in the world, Woodcraft can help you work more efficiently and skillfully than ever. Call for your free copy today.

800 542-9115

www.woodcraft.com

406 Airport Industrial Park Road
P.O. Box 1686
Parkersburg, WV 26102-1686

Visit one of our stores located nationwide! Call us for the store nearest you.

Dept: C06PW060

QUALITY WOODWORKING TOOLS • SUPPLIES • ADVICE™

CIRCLE NO. 168 ON FREE INFORMATION CARD.

"Very simply, they are fabulous machines at excellent prices."

Editors' Pick

American Woodworker - Jan. 2006

Our 3hp Gorilla tested in a class by itself with the most airflow (CFM). Our 2hp Gorilla tested with more CFM than the 3, 2.5, and 2hp competitors except for one 3hp unit.

(See American Woodworker performance results on our website).

2hp Dust Gorilla
2hp Super Dust Gorilla
3hp Super Dust Gorilla

Order On-Line!
www.oneida-air.com
Call Today for FREE Brochure!

1.800.732.4065



Oneida Air Systems

2hp Super Gorilla w/
U.S. made Baldor Motor

Shown with optional Angle Iron Stand.

Duct Design Service Available.

Awards Our Systems Have Won.

WOOD MAGAZINE
TOP TOOL
APPROVED 2005

2001
AMERICAN WOODWORKER
EDITORS' CHOICE

2000
AMERICAN WOODWORKER
EDITORS' CHOICE

1997
WOOD MAGAZINE
EDITORS' CHOICE
TOP TOOL

Who Says Good Help Is Hard To Find?

Home shop or industrial plant, cabinet making, v-carving or 3D crafts – ShopBot CNC tools are perfect for every woodworker!



www.shopbottools.com
888-680-4466

Starts at
\$6,695.00

ShopBot

Tools for tomorrow, today

CIRCLE NO. 142 ON FREE INFORMATION CARD.

CIRCLE NO. 148 ON FREE INFORMATION CARD.

How to Level a Panel: Plane it or Start Over

Jack plane's iron is cambered with an 8" radius

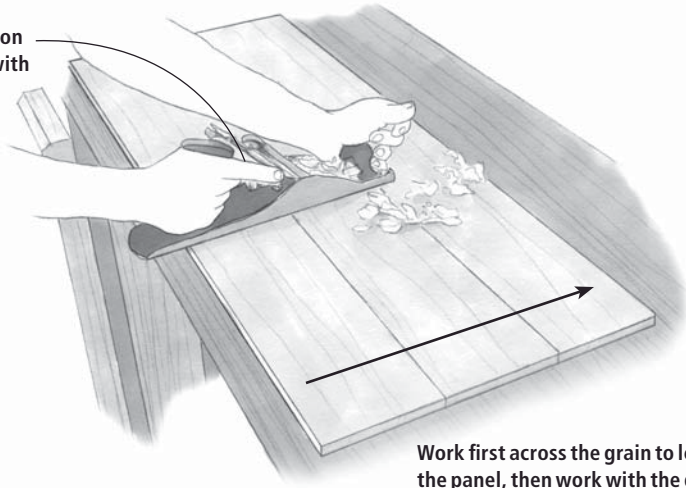

Work first across the grain to level the panel, then work with the grain.

Illustration by Hayes Shanesy

How Should I Level Uneven Joints After Gluing Up a Panel?

I am currently making four mission-style bedside tables. When gluing up the panels for the top and middle shelf, the seams did not come out even. Several of the tops have one of the boards higher than the other.

I don't have a planer, so I tried a handplane on a couple and it made things worse—gouges in the wood and still uneven. I thought about buying hand scrapers but didn't know if that would work. I also haven't had much luck with the belt sander. What would be my best option to get these smooth and even?

Tim Souder
Arma, Kansas

Generally, if the boards are more than $1/16$ " out of alignment, it's usually best to rip the panel apart and try again. It sounds radical, but it's a sound solution. I recommend a band saw to cut the panel apart along the joints, which removes very little material. Then joint the edges again and glue it up. You'll lose little in width.

To avoid this problem in the future, try using splines to align the boards, or a slow-setting glue, or pinch dogs at the ends to keep the ends flush as you clamp the center.

Generally, if a panel's boards are within $1/16$ ", then I use a handplane, which requires some skill, as you know. The trick here is to work at 90° to the grain—across the width. Use a jack plane with a cambered iron (I use an 8" radius on the blade) and you'll have little tear-out. Though it sounds weird, it works, it's easy and historically accurate, too. Then, when the panel is flat, you work with the grain again.

The power-tool guys in our shop level panels with a belt sander or a drum sander. The belt sander requires real skill (like a handplane). The drum sander requires real money.

—Christopher Schwarz, editor

Is it Possible to Use a Lock-miter Bit On Plywood Without Horrible Chip-out?

In the February 2006 issue, Bill Hylton is shown with a piece of plywood casework with lock-miter joints. However, after trying it myself with a couple different brands of bits, I got gobs of chip-out and gave up. When I purchased the second bit, the salesman told me they were never meant for cross-grain work. How do you get decent results in such material as plywood or in cross-grain work?

Rocky Eshom
Shelton, Washington

While using a lock-miter bit cross grain or in plywood is not the easiest, I wouldn't say it wasn't meant for that type of work. The problem is you're reducing the plywood edge to a knife's edge that happens to have a piece of cross-grain veneer as its edge. It's fragile and will be prone to tear-out and damage, no matter what you do.

I do have a couple suggestions. Check the speed of the router and make a couple of test pieces at different speeds. It's possible you're running the bit too fast. The larger the bit, the slower the speed required for a clean cut.

Second, it's extra work, but when running the edge, use a backer board as you would when making a crosscut on the table saw. Rather than try and attach it to the piece, attach it to the fence or table to serve as a guide/backer board.

—David Thiel, senior editor

Q: Where Can I Go For Information on Hand-tool Shops? A: Delaware

I would appreciate advice on how to set up my shop to concentrate on hand-tool use. My shop is 12' x 16' and I have all the basic power tools such as a table saw, chop saw, a planer, a jointer, a drill press and a radial-arm saw.

The furniture I make is "primitive early American" style. I use old wood I have purchased from local farmers that has been removed from their barns and outbuildings.

I would appreciate it if you could tell me how to put together a good tool list in order to build primitive-style furniture. I would like to have a more-than-basic complement of hand tools and would really appreciate advice.

Richard Seabrease
Biglerville, Pennsylvania

Setting up shop is a big topic. First, try to get your hands on our February 2006 issue (#153). In it, Adam Cherubini has an article on the basics of setting up a hand-tool shop—bench placement, tool storage, lighting etc. His "Arts & Mysteries" column in the April issue (#154) is on building a sawbench. And in this issue, he writes about an 18th-century tool inventory. All three of those articles relate directly to your needs.

Other sources I can point you to are slightly indirect and sometimes hard to find—but valuable. There are three out-of-print books that will give you good insights into a hand-tool shop.

"With Hammer in Hand" by Charles F. Hummel can be found in good libraries. This book is an inventory and life story of the Dominy

continued on page 18

EZ-Mount

Hardware Mounting Systems



mount a door in under one minute!

*EZ-Mount is proud to announce
our newest dealer*

Woodworker's HARDWARE
(800) 383-0130

For a complete list of dealers see:

www.ez-mount.com

EZ-Mount Hardware Mounting Systems
1920 E. 3rd. St. Tempe, AZ 85281
(480) 829-1214 FAX (480) 829-6968

CIRCLE NO. 115 ON FREE INFORMATION CARD.



BOB MARINO

Your Personal

FESTOOL

Consultant

Free Shipping!
On Orders of \$150.00 and Up

- "Excellent customer service is my highest priority"
- "I know the Tools"
- "I use the Tools"
- "They are the only Tools I sell"

Bob

See why Festool's lineup of portable power tools is your best choice ~ both in the shop and on-site.

973.896.4388
Glen Ridge, NJ

robarlmar@aol.com
www.festool.safeshopper.com

CIRCLE NO. 107 ON FREE INFORMATION CARD.

Built for Wood

New WOOD PROJECTS™ Construction Adhesive packs the legendary bond strength you expect from LIQUID NAILS® adhesives, plus an innovative EZ Break seal for faster gunning. Guaranteed performance for all wood.

WOOD
PROJECTS™ Construction Adhesive
Multi-Purpose
Guaranteed For All Wood and Paneling
Strong, Durable Bond
UP TO 200% STRONGER*
Than Fasteners Alone
NEW! EZ BREAK SEAL
MAKES A Durable Seal

Rooted in Performance

©2006 ICI Paints. All rights reserved www.liquidnails.com

CIRCLE NO. 135 ON FREE INFORMATION CARD.

Q & A

continued from page 16

family craftsmen with photos of their tools, jigs and floor plans of their shops. It is a gold mine of information.

Even better, I recommend you visit Winterthur (winterthur.org). It's quite close to you. There you can see the reconstructed Dominy shop and even take a look at the book "With Hammer in Hand" (Hummel worked there).

I also like the book "The Tool Chest of Benjamin Seaton," which showcases an early tool chest and its contents.

Finally, "Tools for Woodwork" by Charles Hayward. This book offers advice on hand-tool use and setup, plus lists the tools to get started.

There are some other contemporary sources. But I really think a visit to Winterthur will answer many of your questions.

—Christopher Schwarz, editor

You Gave Us the Recipe For a Stickley Stain, but Which Stickley Stain?

In the June 2005 issue, you replied to a reader regarding duplicating one of the Stickley finishes. Based on your tests, the General Fin-

ishes "Java" stain was recommended. I am also trying to duplicate one of the Stickley original finishes named "Onondaga 32." Based on their catalog, they have at least four different types of finishes for oak (Fayetteville 35, Onondaga 32, Centennial 31 and Limestone 38). Do you happen to know what original Stickley stain the "Java" stain replicates?

Brian Baker
Bethlehem, Pennsylvania

The "Java" stain is close to the "Onondaga 32" from the current L. & J.G. Stickley catalog. I should point out that these aren't really "original" finishes. The current production from L. & J.G. Stickley is finished like most modern furniture with a variety of stains, glazes and toners. Original Gus Stickley furniture was fumed, shellaced and waxed in the early years, and finished with stains made by Sherwin-Williams and early versions of lacquer later on. The colors are similar, but the materials, methods and finished appearance are not identical.

Jeff Jewitt's web site (homesteadfinishing.com) has some good information on how to obtain a close match to most of the colors that were originally used.

If you're trying to match something you have, I'd recommend making several samples and seeing what looks right to you. **PW**

—Bob Lang, senior editor

WRITE TO US

Every day we get questions from readers on all subjects about their woodworking. Some are letters; many are e-mail messages. We are more than happy to share our woodworking experience with you by answering your questions or adding some clarity to whatever aspect of the craft you are unsure about. In addition to the hundreds we answer privately every month, we want to share the best questions here with readers.

Send your questions via e-mail to popwood@fwpubs.com, or by mail to:

Q&A • Popular Woodworking
4700 E. Galbraith Road
Cincinnati, OH 45236

Send a FREE Copy and do a Good Deed!



Help us find a woodworker who becomes a *Popular Woodworking* subscriber, and we'll donate \$5 to a charity!

How can we afford to give away 25% of the subscription price? The simple fact is, your referral saves us money we'd otherwise spend to find new subscribers — we'd rather give back to the community and the environment than pocket the savings. So, we're donating \$5 of every subscription through this program to the American Cancer Society (cancer.org) and The Nature Conservancy (nature.org).

Yes! I'd like *Popular Woodworking* to send a **FREE** copy of the magazine to the recipient I've listed. I understand that if my referral becomes a subscriber, *Popular Woodworking* will donate 25% of the subscription price to charity! (And don't worry — we won't rent or sell your friend's name or address.)

Fill out this coupon and send to:

**POPULAR
WOODWORKING**

c/o Circulation

4700 E. Galbraith Rd., Cincinnati, OH 45236-9837

Name _____
Address _____
City _____
State _____ ZIP _____

To send a FREE copy even faster, visit
www.popwood.com/charity.html

U505AD

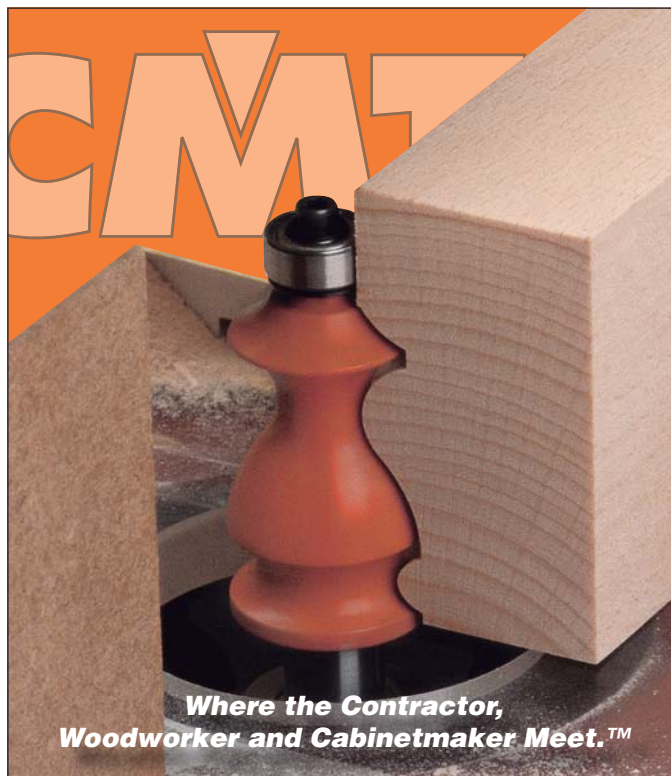

Where the Contractor,
Woodworker and Cabinetmaker Meet.™

**CMT ORANGE
TOOLS™**

CMT USA, Inc. 307-F Pomona Drive Greensboro, NC 27407
888-268-2487 • 336-854-0201 • Fax: 336-854-0903 • www.cmtusa.com

ROBERT LARSON COMPANY



Supplying quality woodworking hand tools
to fine stores & catalogs since 1981.

USA importer of *Two Cherries Tools*



WWW.RLARSON.COM ~ 800-356-2195



CIRCLE NO. 145 ON FREE INFORMATION CARD.

EZ-Mount

- Woodworkers
- Cabinet Makers
- Do-it-yourselfers
- Installers
- Builders



The EZ-Mount hinge plate jig and door hinge centering guide lets you install a cabinet door in no time flat... and do it perfectly every time!

In stock
\$19⁹⁵

For your complimentary
catalog, call
(800) 383-0130

**Woodworker's
HARDWARE**

Visit us online at
woodworkershardware.com Promotion Number 482



CIRCLE NO. 160 ON FREE INFORMATION CARD.

JessEm
Tool Company

Love At First ...Slide!

THE NEW

Mast R Slide™

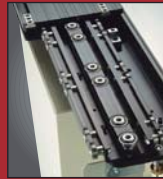

JessEm's New **Mast-R-Slide™** Precision Sliding Cross-Cut Table is the ultimate add-on for your tablesaw. Thirty double-sealed precision bearings in an innovative linear guide mechanism provides an exceptionally smooth and accurate cross-cutting solution. Fits most tablesaws and offers a maximum cross-cut of 36 inches. Upgrade your saw with a **Mast-R-Slide™** from JessEm Tool today.



Visit us at www.jessem.com
Call: 866-272-7492 • Barrie, Ontario Canada

CIRCLE NO. 129 ON FREE INFORMATION CARD.

Serious Sharpening Systems for Precision Edges



Mk.II Cabinetmaker's Sharpening Set

Ideal for chisels and plane blades, the Veritas® Mk.II Honing Guide sets a practical range of bevels, back bevels and micro-bevels. An integral blade registration system squares the blade and sets the angle in one easy step, for quick, accurate sharpening and perfectly repeatable results, reducing unnecessary stone and blade wear. The set includes an 8"x2"x1", 1000x/4000x combination stone.

05D05.03 Set with Mk.II Honing Guide \$68.50



Deluxe Power Sharpening Set

With this combination, you can easily do accurate grinding with utility bench grinders. Includes a 6"x3/4" 80x white aluminum oxide wheel, a Veritas® Grinding Jig, plus a Veritas® Grinder Tool Rest (with angle-setting gauge).

05D12.01 Deluxe Power Sharpening Set \$75.00

Shipping and N.Y. sales tax extra.

See these sharpening systems and 5000 other woodworking tools in our free 260-page catalog. Call or visit us online.



Veritas® Mk.II Power Sharpening System

Razor-sharp blades can be achieved in a matter of minutes. The system is so easy to use that perfect results are possible by someone who has virtually no experience sharpening blades.

05M31.01 Mk.II Sharpening System \$319.00



Lee Valley & veritas®

P.O. Box 1780, Ogdensburg, N.Y. 13669

1-800-683-8170
www.leevalley.com

CIRCLE NO. 133 ON FREE INFORMATION CARD.

POPULAR WOODWORKING
Best NEW TOOL 2004

Fine WoodWorking MAGAZINE
BEST VALUE FOR THE MONEY

Introducing our **AWARD-WINNING 8" Stacked Dado Set... The Dadonator™** Exclusive 6-Tooth Chipper Design!

Item #SDB-800
Only \$179.90

Visit infinitytools.com for what's new & innovative in wood cutting tools!

• Router Bits • Shaper Cutters
INFINITY CUTTING TOOLS
• Planer/Joiner Knives • Saw Blades

TOLL FREE 877-872-2487

CIRCLE NO. 126 ON FREE INFORMATION CARD.

SQUARE DRIVE

- Square Drive Beats Driver Bit Slippage
- Hardened Steel for Extra Strength
- Deep Thread for Super Grip
- Over 750 Sizes & Styles

McFEELY'S
SQUARE DRIVE SCREWS

PO Box 11169 • Lynchburg • VA 24506
www.mcfelys.com or 1-800-443-7937

CIRCLE NO. 138 ON FREE INFORMATION CARD.

Dovetail your next drawer – in less than 10 minutes...

including setup!

only with the Keller Dovetail System.

All other jigs require endless test cuts and wasted wood.

The Keller Dovetail System is very different: it is easy, quick, accurate and versatile.

Cut unlimited widths. Classic and variable spacing. Angled and curved dovetails. Box joints. Projects from jewelry boxes to entertainment centers. 20-yr warranty.

VIDEO: \$8.95 + \$2 P/H

KELLER & CO. Dept. P56
1327 T Street, Petaluma, CA 94952
(800) 995-2456 (707) 763-9336

www.kellerdovetail.com

The Keller Dovetail System
Simply the best.



CIRCLE NO. 131 ON FREE INFORMATION CARD.

TRICKS OF THE TRADE

Compiled by Paul Anthony
Illustrations by Matt Bantly

Wedged Frame Clamping

THE WINNER:

Clamping with wedges is a trick that's been around a long time, and it can be a particularly great way to clamp mitered frames. However, most of the miter-clamping fixtures I've seen in my many years of woodworking are complicated to make and cumbersome to use. Here is my version of a simple frame-clamping jig that I have been using for many years. Built from scrap materials, this type of jig can be custom-made to suit any frame, whether square, rectangular or polygonal.

Basically, the jig consists of scrap-wood retainers fixed to a piece of flat plywood or other panel, with the workpiece wedged between the retainers, using shims as shown. The retainers can be made from 1x2 stock or whatever you have on hand that suits your frame. Cedar shake shims are commonly available at building-supply centers.

In the case of a square frame, only one retainer corner needs to be truly square, as shims will compensate at the other corners. Stop the retainers short of the frame corners if you want access to reinforce the joints with nails or other fasteners. Use waxed paper or

Retainers can be made from 1x2 stock

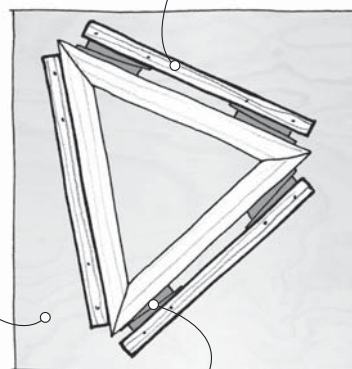

Base

Use common cedar shims from a building-supply center

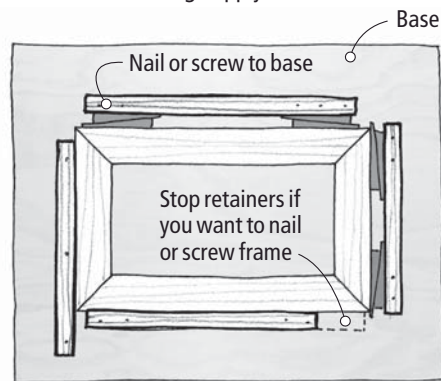

Base

Nail or screw to base

Stop retainers if you want to nail or screw frame

brown painter's tape at the frame corners to protect the jig against glue squeeze-out.

Frank Namowicz
Plainfield, Illinois

CASH AND PRIZES FOR YOUR TRICKS AND TIPS!

Each issue we publish useful woodworking tips from our readers. Next issue's winner receives a Veritas Mk. II power sharpening system. The combination of interchangeable abrasive discs and a simple tool rest make sharpening hand tools simple and quick.

Runners-up each receive a check for \$25 to \$100. When submitting a trick (either by mail or e-mail) you must include your complete mailing address and a daytime phone number. If your trick is selected for publication, an editor will need to contact you. All entries become the property of *Popular Woodworking*. You can send your trick by e-mail to popwoodtricks@fwpubs.com, or mail it to Tricks of the Trade, *Popular Woodworking*, 4700 E. Galbraith Road, Cincinnati, OH 45236.



veritas Tools Inc.

Easier Drawer and Box Clamping

When gluing up a bunch of small drawers recently, I quickly tired of juggling eight glue blocks and eight clamps for each drawer. I set about finding a better way, and soon came up with these shop-made clamps, which reduced the juggling act to four items.

Each clamp consists of two lengths of threaded rod and two wooden cauls, one fixed and one moveable. The fixed caul is held in place at one end of the rods with nuts and washers, while the moveable caul is held on with knobs. I made one pair of clamps 18" long and the other 12" long, which accommodates most of the small drawers and boxes I make. I used poplar for the $\frac{7}{8}$ " square x 10" long cauls because it is relatively soft and won't mar workpieces.

Holes in each caul allow repositioning the rods to accommodate various sizes of drawers. When clamping, I usually set up the pairs of clamps perpendicular to each other, offsetting

the rods in one pair so they won't interfere with the rods in the other pair. For one pair of clamps, I located each of the innermost holes 2" outward from the center of each caul, then spaced the subsequent holes at 1" intervals. The hole layout for the second pair of clamps is the same, except the innermost holes start 2½" from the center. Drill the holes to suit the diameter of your threaded rod. I use 5/16"-diameter rod, but ¼"- or 3/8"-diameter rod would also work.

Before assembling the clamps, plane or sand a slight bow into the clamping face of each caul so it's about 1/16" thinner toward each end. This will ensure clamping pressure at the center of the caul in use. Also, cover the clamping faces with a layer of plastic-packing tape to keep the clamps from becoming one with your project.

Ken Burton
New Tripoli, Pennsylvania

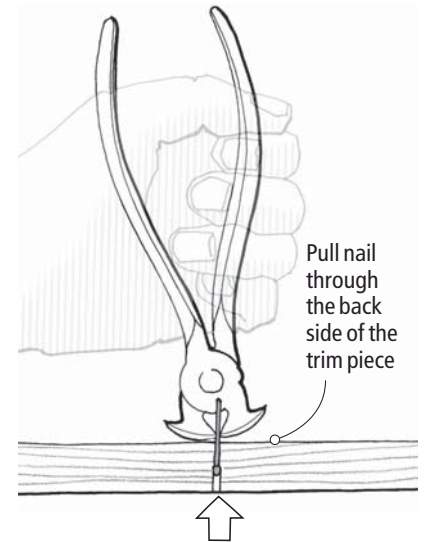
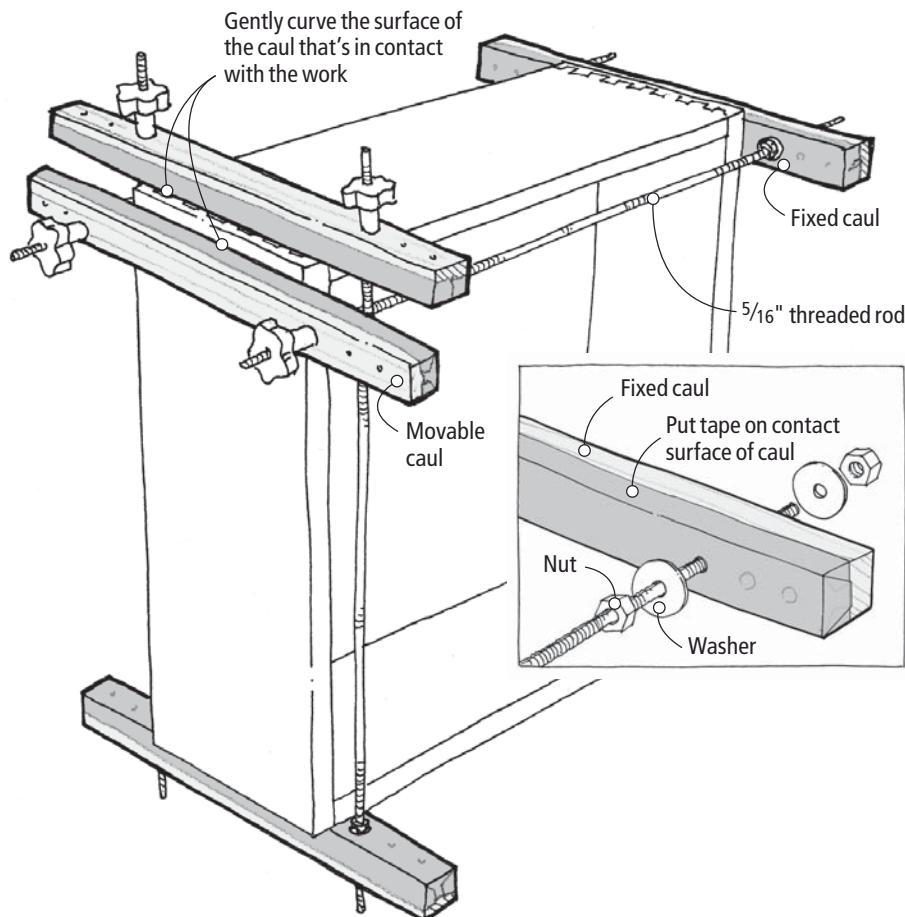

Pulling Trim Nails

It's not uncommon to have to remove a piece of trim to reposition it, whether it's moulding on a piece of furniture, a stop strip on a household door or a wooden sash window. Of course, after prying the trim off, the finish nails that were holding it in place need to be removed. The natural inclination is to simply hammer them back out in the direction of the head. Unfortunately, this often causes blowout on the "show" side, especially if the nails had been set below the surface.

A trick I learned from an old carpenter will prevent such damage. Instead of hammering the nails out backwards, grab the shank on the exit side with end-cutting pliers, and yank the nail completely through the workpiece. Whatever small damage the head of the finish nail causes passing through will be on the underside of the trim, and will never be seen.

Bob Farmer
Sebastopol, California

A Hot Way to Cut Rope

I find the best way to "cut" polypropylene rope or cord is to use a hot soldering iron with a wedge-shaped tip. Not only does this make a clean cut, it fuses the strands at the same time, preventing unraveling and frayed ends.

Stanley Krasovic
Honesdale, Pennsylvania

Simple Guides for Handplaning

When handplaning boards, it can be helpful to have a reference that indicates your progress. I've found that simple chamfers cut on the edges of the workpiece serve well. Here are a couple of approaches I use when planing both edges and faces of boards.

When jointing the edge of a board, I first mark the desired edge. Then, at each end of the board, I use a chisel to cut a small chamfer that extends from the rough edge to the desired cutline. The chamfers serve as a great visual aid, indicating how much further there is to plane until they disappear.

When thickening a board, I first plane one face flat. Then, registering the fence of a marking gauge against the planed face, I scribe a line at the desired thickness on the edge of the board. I use a block plane to cut a chamfer all around the edges, extending from the unworked face to the gauged line. Starting with a long plane, and finishing with a smoothing plane, I work the face of the board down until the chamfer disappears.

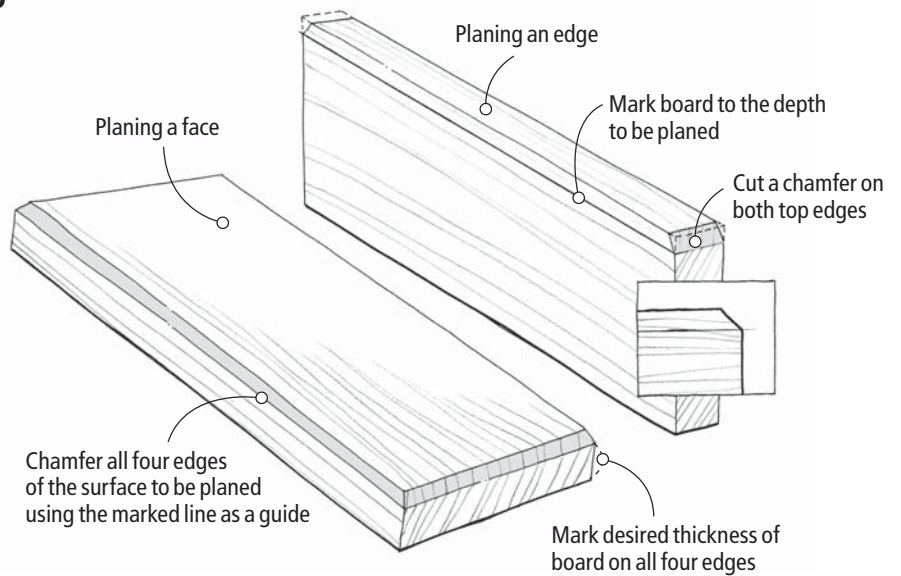

When working with dark woods, I find it helpful to mark the chamfers with white chalk for better visibility.

*Louis Giolitto
Surrey, England*

EXTENDED
SIDE PROFILE
EXCLUSIVE
DESIGN

GLUE-RESISTANT
RESIN JAW FACE

ERGONOMIC
SUMOGRIP®
HANDLE

SLIDE-GLIDE™ TRIGGER
(PATENT PENDING)

BENCH CLEARANCE

SLIDE-GLIDE™

EASILY ENGAGES OR RELEASES PARALLEL

Voted "Best New Tool" for its tremendously innovative and easy to use features, the all-new JET® Parallel Clamp simplifies clamping action with its exclusive *Clutch Design* and *Slide-Glide™ Trigger*. See your next set of clamps in action at a quality JET woodworking dealer nearest you or at jettools.com/pw



PARALLEL JAW CLAMPS

Separating Wood Plugs

A plug cutter used on the drill press will cut wooden plugs for filling counterbored screw holes. However, after drilling the plugs in a strip of scrap, it's necessary to cut them free. The time-honored trick here is to apply a strip of tape to the heads of the plugs before sawing them free on the band saw or table saw. However, I've found that the separated plugs often don't stick to the strip of tape after the cut, and instead fly off the saw table into some mess on the shop floor.

I've discovered that a better approach is to drill a row of plugs right near the edge of the scrap, so that the cutter intersects the edge. That way, each plug can easily be cut free with a chisel as needed.

*Polly Seville
Salt Lake City, Utah*

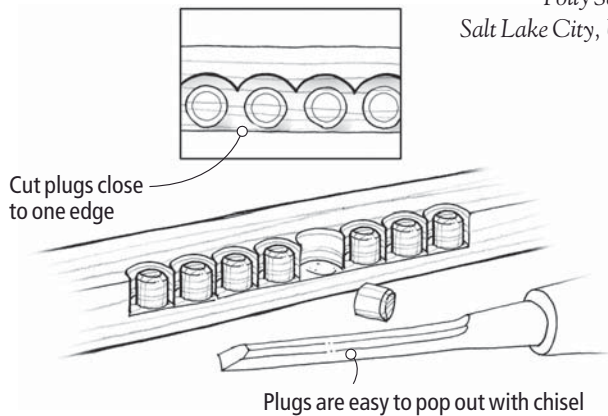

An Extra Hand for Vise Clamping

A wooden handscrew clamp clamped upright in a workbench vise provides a good way to hold a workpiece on edge. It works particularly well for pieces too long to fit between bench dogs. I've found that a handscrew with 8" jaws generally suits my work. Depending on your vise and workpiece, a larger or smaller handscrew might serve you better.

*Barlowe Jackson
Oxter, New Jersey*

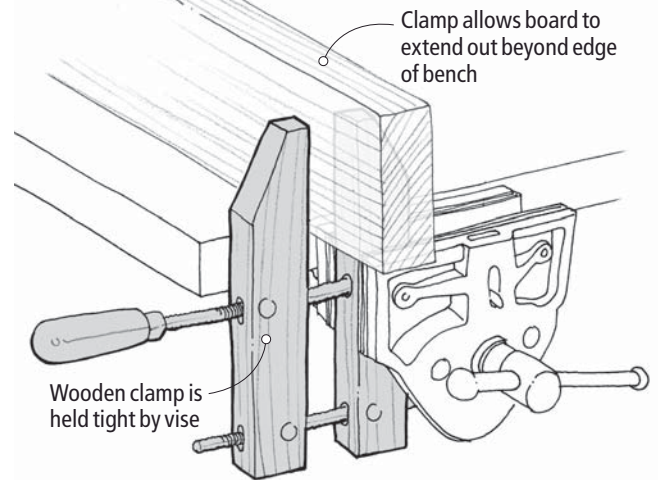

INSERT INTO A WORKBENCH



CONVERT TO A SPREADER

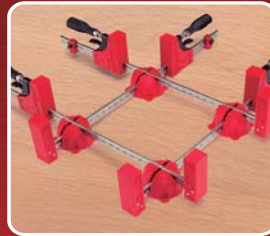

CLAMP IN A 90 DEGREE SETUP

PRECISION-RULE™
MEASUREMENT SYSTEM
(PATENT PENDING)

MOVEABLE RAIL
STAND/END STOP
(PATENT PENDING)

13| 14| 15| 16| 17| 18| 19| 20| 21| 22| 23| 24| 26| 27| 28|

BENCH DOG™ PEG
(PATENT PENDING)

TRIGGER

(PATENT PENDING)

JAW FOR RAPID ADJUSTMENTS.



STAND/END STOP

A kickstand at the end of the bar prevents clamp tipping and bar flex.



BENCH DOG™ PEGS

Maximizes clamp stability. Converts to 11/16" length to work with 3/4" material.



CROSS DOC™

Framing block with dual slots for fast 90 degree setup.

JET

BUILT BETTER TO BUILD BETTER™

SPEED-COPE™ JIGSAW COPING JIG

The **FAST, EASY** way to cope crown and base moldings!

FREE How To DVD when you order!

USE YOUR POWER JIGSAW FOR ALL YOUR COPING!

SPEED-COPE
A POWER-COPIED JIG

\$189⁹⁹ plus shipping

For additional information/ordering: www.speedcope.com or call toll-free 1-800-755-8146

CIRCLE NO. 149 ON FREE INFORMATION CARD.

WHITECHAPEL LTD

Over 4000 fine hardware essentials



English Gothic Revival Ring Handle

315 PAGE COLOR CATALOG \$5.00
1-307-739-9478 whitechapel-ltd.com

CIRCLE NO. 155 ON FREE INFORMATION CARD.

SUPERSHOP 10-IN-1 WOOD & METAL SHOP

Own a Complete, PRO-QUALITY WOOD SHOP In Just 12 SQUARE FEET!

The HIGH QUALITY, AFFORDABLE ALTERNATIVE for TIGHT SPACE shops!

- Equal or **BETTER QUALITY** and **COSTS LESS** than several one-function machines.
- **10 MOST-USED TOOLS IN 1:** table saw, lathe, drill press, more!
- 2½ times **MORE** **MASSIVE** than other combo machines.
- **ELECTRONIC SPEED** controls, powerful DC motor.
- Perfect for **HOME & PROFESSIONAL** shops.
- **30-DAY RISK FREE** Trial & Industry-Leading Warranties.



Stand-alone machines take TOO MUCH ROOM!

10 TOOLS IN JUST 12 SQ. FT.!

CALL TOLL FREE 1-800-476-4849 **FREE!**

Or Mail to: SuperShop® Dept. PW, P.O. Box 1517, Ann Arbor, MI 48106-1517

YES! RUSH me all the details on the HIGH QUALITY, AFFORDABLE alternative for TIGHT SPACE wood shops!

Name _____
Address _____
City _____ State _____ Zip _____

CIRCLE NO. 172 ON FREE INFORMATION CARD.

TRICKS OF THE TRADE

Biscuit Joiner 'Trim Saw' Makes Floor Installation Easier

I was installing a new hardwood floor recently and needed to cut off about 3/4" from the bottom edge of the trim on several doors in order to run the flooring underneath the jamb and door casing. I tried using a handsaw, but had limited success, as I found myself scraping my knuckles on the floor, and getting out-of-square cuts in the process. I considered removing the casing trim to cut it more easily, but the jamb would still present a problem.

It dawned on me that I might be able to use my biscuit joiner for the job. My joiner has a fixed fence, which I removed in order to be able to press the face of the joiner entirely against the piece to be cut. (If your joiner has an adjustable fence, it can simply be swung

up flat against the tool's face.) I set the depth-of-cut gauge at its maximum (the #20 biscuit setting on mine), and placed the tool on a 1/4"-thick plywood shim so the top edge of the cutter would meet my cutline. I turned the tool on, plunged the cutter into the wall, and moved the tool sideways making overlapping plunge cuts to cut through the casings and jamb on each door. It worked great, cutting entirely through the casings, and most of the way through the 3/4"-thick door jambs – a cut I was then able to easily finish up with a handsaw. Obviously, the tool can be used to cut other types of trim as well.

Steve Reid
Langhorne, Pennsylvania

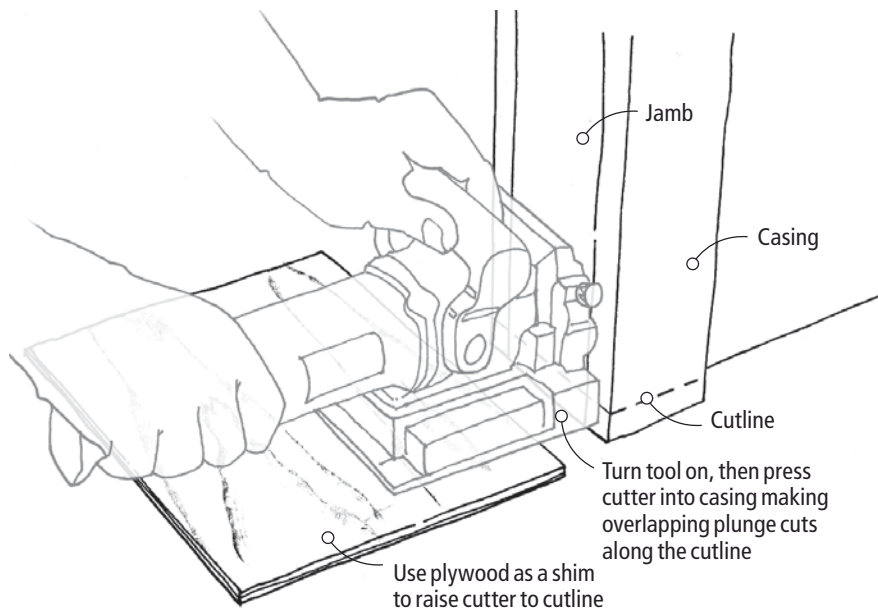

Shortening Screws – the Easy and Consistent Way

It's not uncommon to have to shorten wood screws so you can use sizes you have on hand instead of making a special trip to the hardware store. I used to just clamp a screw to be shortened in a pair of locking pliers, then grind it off to a mark I made on the screw. This was a bit awkward, though, as the screw would tend to deflect under pressure, and the pliers could mar the edges of the head. Fortunately, I've found a much quicker and most accurate way to do the job.

First, I drill a pilot hole through a small scrap of wood whose thickness matches the

desired length of the screw body. After driving the screw home through the pilot hole, the screw is held securely by its threads, and the correct amount of excess projects through the opposite side of the scrap for easy grinding. I just press the screw tip against the grinding wheel until the scrap block contacts the wheel. There's no deflection or scarring of the screw, and it's ground to the perfect length. Quickly remove the screw with a power driver, and you're ready for the next one.

Tim Dauber
Albuquerque, New Mexico

Plan to Hide Mistakes

In the course of my woodworking endeavors, it seems I'm always trying something new – and not always successfully. Maybe it's a new joint, or a new trimming operation or even (shudder) a new finishing technique. In the process, I've learned a lot of tricks, but two of the most important are to practice first on a test piece, then to do the actual work on the piece beginning with the most hidden areas.

Working with a test piece allows you to get the basic feel of the operation – how the tool cuts, or how it feels in your hand when held in an unfamiliar way. But no matter how well the practice run goes, I've also learned to begin the real process on the least evident sections of the actual project, which gives me more familiarity with the process before I attack the all-important primary “show surfaces.” For example, it makes sense to rout a decorative rabbet in the edges of a cabinet's rear legs before doing the front legs. That way, if the bit was set wrong or if it slips, the error won't be so apparent. Even something as simple as handplaning the underside of a tabletop first may save you the unpleasant discovery that the wood you're using tears out like crazy, and will need to be scraped or sanded instead. Anyway, working this little “trick” into my regular repertoire has saved me some embarrassment over the years.

Robert Marples
Perth, Australia

Tape Rule Shims

Like many of you dusty packrats, I tend to hang on to all manner of scraps, including leftover sections of self-adhesive measuring tape that I've used on jigs. I find that this stuff makes great shim material because it's thin, durable and self-adhesive. It's easily cut into appropriate-sized strips for shimming fences and jig parts, but it can also be cut into very small pieces if necessary. For example, I have affixed short, narrow pieces of it along the underside edges of recessed machine table inserts to bring them flush to the table. Whenever I need to shim something, it's one of the first things that comes to mind. **PW**

Paul Anthony, PW contributor

WE HAVE THE
Pattern

BITS THAT YOU NEED FOR YOUR NEXT ROUTING APPLICATION

Use a pattern jig to smooth each piece to final size

"The most efficient method of routing multiples is with a pattern bit."
Lonnie Bird

Tool No. 45460
\$2243
List Price \$29.00

Ask Lonnie Bird
Question and Answer column at
www.amanatool.com

Amana Tool
High Performance Cutting Tools

www.amanatool.com For a dealer nearest you call (800) 445-0077

CIRCLE NO. 102 ON FREE INFORMATION CARD.

Try our DR® FIELD and BRUSH MOWER for 6 MONTHS RISK-FREE!

We're so sure you'll love it, we're willing to extend to you this unusual invitation to use our self-propelled, walk-behind brush cutter on your property!

- **CLEAR & MAINTAIN** meadows, pastures, roadsides, fencelines, walking paths with ease!
- **CUT** tall grass, weeds, brush, brambles — even saplings up to 2-1/2" thick!
- **CHOP/MULCH** most everything you cut!

If this is not the hardest-working, most durable, easiest-to-use machine for clearing fields and brush that you've ever used, we'll take it back and give you a complete refund of your purchase price!

FREE SHIPPING
Now in Effect!

CALL 1-888-293-2567

YES! Please rush me your full-color Catalog and Demonstration DVD on the DR® FIELD and BRUSH MOWER, including models, prices, your 6-MONTH RISK-FREE TRIAL, and how I can now receive FREE Depot Delivery!

Name _____ PWD

Address _____

City _____ State _____ ZIP _____

E-mail _____

DR® POWER EQUIPMENT, Dept. 53244X
127 Meigs Road, Vergennes, VT 05491

www.DRfieldbrush.com

© 2006 CHP, Inc.

Minas Tirith Shutters

No joints.
Just jigsaw and go.

After Hobbit Frodo Baggins destroys the One Ring in Peter Jackson's epic film "The Return of the King," there's an emotional reunion scene when Frodo wakes up in the city of Minas Tirith and is reunited with his long-lost friends.

While most viewers were transfixed by the hugging Hobbits, all I could say was, "Look at those cool shutters on the windows."

After some design work with some French curves, we produced this version of the shutters. They are astonishingly quick and easy to build with a minimum number of tools, off-the-rack pine and hinges. The most complex part of this project is in the planning.

Begin by measuring carefully the height and width of your window opening. Measure at the top, bottom, left and right. Now you need to figure out how wide your boards should be to do little or no ripping. All dimensional stock is undersized. You'll probably want to choose



a combination of 1 x 4s (which are really 3½" wide), 1 x 6s (5½" wide) and 1 x 8s (7½" wide) to cover your window. Don't forget to allow for the gap created by the hinges. Each row of hinges will add about 3/16" to the overall width of your shutters.

Cut your boards to width and length. If you are going to make more than a few of these, I would make a cardboard or wooden pattern of the designs for the leaves and the bloom. Lay out the bloom at the top of the shutter. Measure the remaining height on your shutter and position the leaves in the middle of that height. Make a few practice cuts on scraps first. Then, cut out the leaves and the large part of the bloom with your jigsaw.

The stamens of the bloom are easier than they look. With a nail or awl, prick the center of each hole shown on the illustrations. Drill a 3/8"-diameter hole with a brad-point bit at each location. Connect the two holes with pencil lines and jigsaw out the waste. Clean



up all your jigsaw cuts with a file, rasp and sandpaper. Sand your shutters.

Join the mating pairs of shutter with your hinges. If your shutters are less than 48" high you can use two hinges. Bigger shutters need three hinges. Now add the hinges that will connect the shutters to the window. To hang the shutters, use commercial wooden shims to position the shutters in the opening and hold it there while you mark the location on the window frame for the hinges. You might have to tweak the edges with a block plane to get everything to fit. A magnetic catch at top and bottom does wonders to hold the shutters closed and in line with one another. Finish them to suit your castle's decor. **PW**

ABOUT THIS COLUMN

Our "I Can Do That" column features projects that can be completed by any woodworker with a modest (but decent) kit of tools in less than two days of shop time, and using raw materials that are available at any home center. We offer a free online manual in PDF format that explains all the tools and shows you how to perform the basic operations in a step-by-step format. You'll learn to rip with a jigsaw, crosscut with a miter saw and drill straight with the help of our manual.

To download the free manual, visit ICanDoThatExtras.com.

by Christopher Schwarz

Chris is the editor of Popular Woodworking and a long-time geeky fan of J.R.R. Tolkien's work. Contact Chris at 513-531-2690 ext. 1407 or chris.schwarz@fwpubs.com.

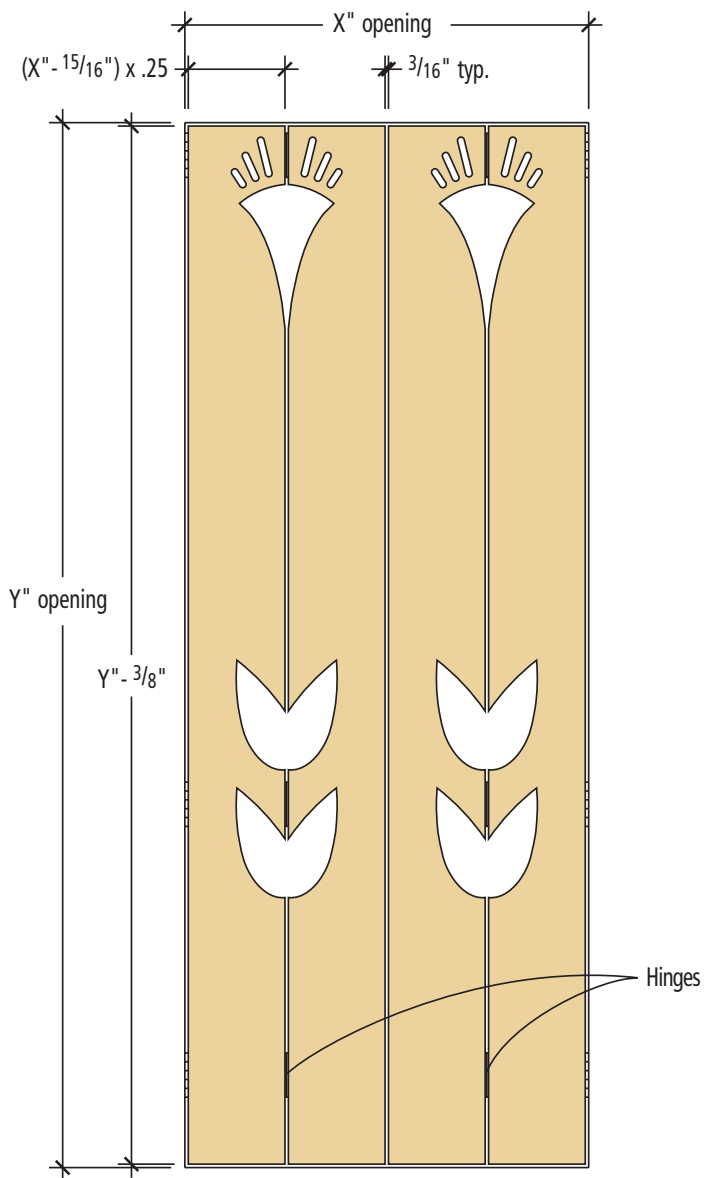

Elevation

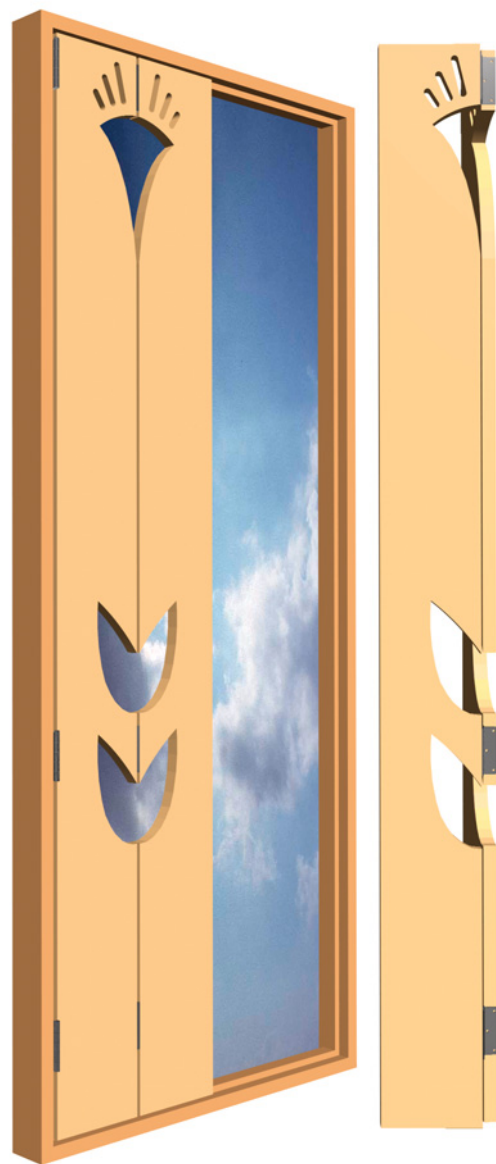

Shutters flat & folded

Drill $3/8''$ holes, connect the tangents, and cut out the waste.

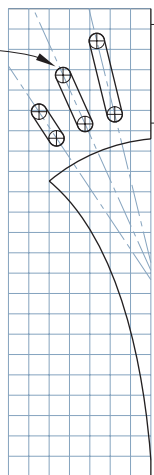

1 square = $1/2''$

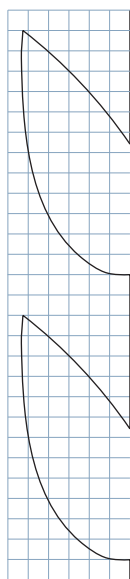

1 square = $1/2''$

Cutout patterns

SUPPLIES

Any Home Center/Hardware Store

6 • Stanley utility hinges, $2\frac{1}{2}''$, zinc finish #819060, \$2.59/pair

4 • 1 x 6 x 8' select white pine boards, \$13.95 each. Choose No. 2 boards if you're going to paint them or want a more rustic look.

Prices correct at time of publication.

Ridgid Router a Bright Addition to the Category

This is the first true router to bear the Ridgid name. A trim router was introduced about one year ago, but this is the one we've been waiting for. And for a first router this dual-base model, well... shines!

First off, this router performs well. The 12-amp motor with electronic feedback provides plenty of power. I tested edge profiles and 3/4"-x 1/2"-deep groove cuts in a single pass in white oak with no problems. The motor's soft start provides a pleasant and safe experience, and the noise level isn't unpleasant, either.

Both bases have clear baseplates that provide a good view of the work. Even better, a pair of L.E.D. lights mounted to the motor wash the work area in illumination.

Though the motor has a collet lock, Ridgid also included two wrenches. I appreciate this little extra as I find uses for both methods during different routing operations.

The plunge base was smooth during use, but I thought the plunge lock flipped too far to the center of the router, making it a reach for my hands to grab while I was holding on

to the handles. I appreciated the addition of a dust-collection-attachment accessory for the plunge base, but with shorter bits the hole in the accessory was too small to allow the collet to reach far enough to make the cut. The depth adjustment was decent, but nothing special. I'd still like to see a micro adjust that works on one of these two-base plunge router kits.

The fixed base comes with a useful centering cone. The base is set up for use in a router table and includes a through-the-base adjustment mechanism. One upgrade might be to have indicator marks on the wrench and the base to gauge the changes in bit height in a router table. This feature is offered when using the router freehand. The quick bypass on the depth adjustment is nice, allowing fast adjustments with or without the fine-adjust mechanism in play.

The Ridgid R2930 is a good addition to



SPECIFICATIONS

Ridgid R2930 Router
 Street price: \$199
 Motor: 12 amp, variable speed (10k - 23k)
 Performance: ●●●●○
 Price range: \$\$\$
 Ridgid: 800-474-3443 or ridgid.com

the dual-base router category. It's priced competitively and with the added bonus of work lights, it stands apart from the crowd.

—David Thiel

For more information, circle # 164 on Free Information Card.

Quick-Stop Drill Press Table

Dead-on accuracy from a drill press table isn't necessary for woodworkers. But it sure is nice to be able to hold your work securely, and have a fence that guides the work with convenient stops for repeated cuts. Drill-press manufacturers haven't bothered to provide such an animal with their machines, so it's up to us to add it after the fact.

Aftermarket drill press tables either go too far or not far enough. The Quick-Stop LP from Woodpeckers is just about right. Priced at \$129 (which is a little higher than we'd prefer, but acceptable) you get a good-sized table with four T-track inserts (two with scales). The tracks support the included two hold-downs (nice, convenient and solid) and a just-right fence.

The fence is a good length for woodworking needs and isn't so tall that it interferes with the drill press chuck or handles. While the fence provides the necessary height for most drill press activities, there are applications where a taller fence would be advantageous, such as mortising. In those instances an auxiliary fence can be added. The fence is easily

adjusted to the left or right with quick-release cam locks and from front to back with knurled knobs. But my favorite features are the two 1"-wide flip stops – there when you need them, and out of the way easily when you don't.

Every woodworking drill press should come from the manufacturer complete with a table like this. But until that happens, it's nice to know that the Woodpeckers Quick-Stop table is there for us.

—DT

For more information, circle # 165 on Free Information Card.

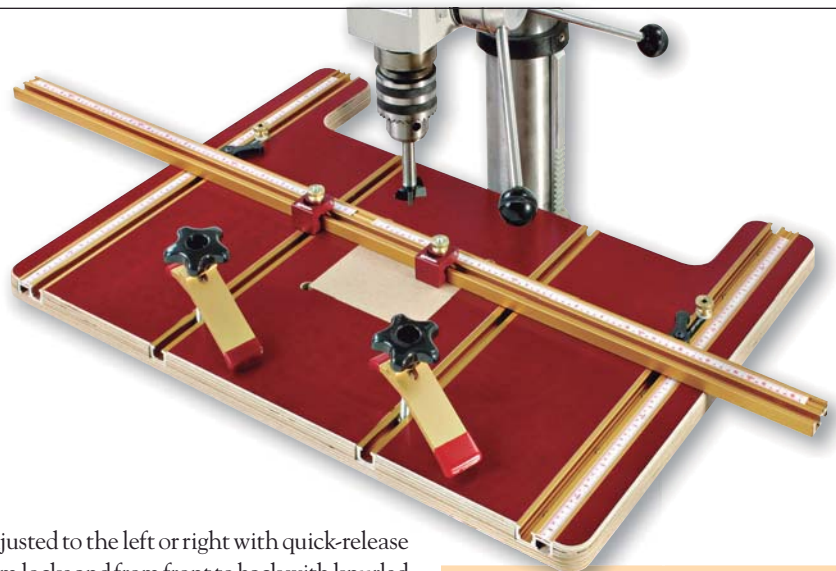

SPECIFICATIONS

Quick-Stop LP Drill Press Table
 Street price: \$129
 Table size: 23 3/4" x 17 3/4"
 Fence size: 1/2" x 1 1/4" x 36"
 Performance: ●●●●●
 Price range: \$\$\$
 Woodpeckers: 800-752-0725 or woodpeck.com

Find the Best Woodworking Books at Borders

The ultimate guide to building high-end period furniture, with a DVD featuring real-time demonstrations and full-scale printable plans.

\$29.99

ISBN 1-55870-770-0

Hardcover with concealed spiral • 128 pg with DVD



David Thiel's
**power tool
maintenance**



This is the only book available that provides in-depth information about woodworking tool maintenance for peak performance and long life.

\$24.99

ISBN 1-55870-755-7

Paperback • 128 pg

Forty plus projects illustrate masterful techniques for using the table saw to achieve a variety of safe and accurate cuts.

\$24.99

ISBN 1-55870-677-1

Paperback • 192 pg

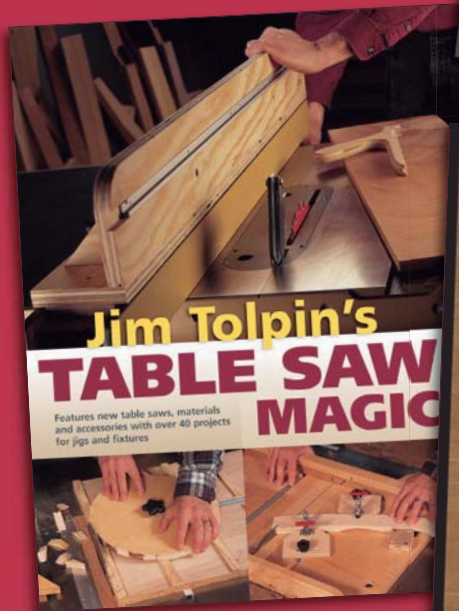

THE COMPLETE
**CABINET
MAKER'S
REFERENCE**

INCLUDES OVER 160 WORKSHEETS!

Includes material and cutting lists and assembly instructions for any cabinet size

JEFFREY PIONTKOWSKI

Jeffrey Piontkowski has written a cabinetmaker's dream reference, with cutting lists, assembly instructions and informative photos.

\$29.99

ISBN 1-55870-757-3

Hardcover with concealed spiral
256 pg



POPULAR
WOOD
WORKING
BOOKS

is an imprint of F+W Publications, Inc.

fw
F+W PUBLICATIONS, INC.

BORDERS®

Grizzly's Baby Drum Sander Rocks

Early in my career I was spoiled forever by a 42"-wide, three-head wide-belt sander. I can't keep from comparing other sanders to that, and this new drum sander from Grizzly isn't that kind of machine. But it is, without a doubt, the best value in a thickening sander suitable for small-shop use that I have seen.

Many small-scale sanders use lightweight materials and leave one end of the machine open to gain width capacity. Grizzly has taken a different approach—keep it simple and solid. It has some limitations in capacity and precision, but considering performance and price, this is the machine I want in my shop.

It won't sand a wide tabletop or a wide assembled door, but it can sand the parts before you put things together. I'd rather put together good parts than risk making more work with an unpredictable machine. I found no sniping or variation across the width from the pieces I sanded with the G0459.

It was hard to hit a precise thickness due to the flexibility in the hook-and-loop abrasives, but this flexibility eliminates many of

the problems found in rigid drums. It's a trade-off I'm willing to make.

Setup was minimal; I needed only to attach the crank handle and dust port. The drum and drive motors had plenty of power and changing the abrasives was simple and painless. The conveyor belt is the same rubber found on industrial machines, and the gear-driven four-post height adjustment operated smoothly.

The pluses outweigh the minuses, but it isn't a perfect machine. I'd move the speed control to the same side as the other controls, and change the knob that holds the lid down. If the hood were extended down, the dust collection would be improved, and the requirement to tape the ends of the abrasive rolls doesn't seem right. I can easily live with these shortcomings to gain the performance, ease of use and predictability of this machine.

— Robert Lang

For more information, circle # 166 on Free Information Card.



SPECIFICATIONS

G0459 12" Baby Drum Sander

Street price: \$425

Sanding Capacity: 12" wide x 3³/₄" thick

Drum: 4" diameter, 3" hook & loop abrasive

Motors: 1¹/₂ hp, 110v drive, 1/10 hp feed

Performance: ●●●●○

Price range: \$\$

Grizzly: 800-523-4777 or grizzly.com

Wenzloff & Sons Backsaws Make the Cut

The hand-tool crowd lives and dies by the hand saw. But even for the rest of us, no matter how many electrons we consume in our shops (and I consume my fair share) we all need a couple decent hand saws for the all-too-common tricky cut.

Now we have one more choice when selecting the right saw. Veteran cabinetmaker Mike Wenzloff of Forest Grove, Ore., has recently taken up custom sawmaking as his primary business and his early offerings are excellent. Thanks to his long career as a professional woodworker, Wenzloff's backsaws are exceptionally functional and a joy to use—the wood, split brass nuts and brass back are expertly finished to a high degree.

I test drove two of his adaptations of the now-vanished Disston No. 9 backsaw—one saw was filed with rip teeth and the other with crosscut teeth. The saws are surprisingly large (20¹/₂" long) and heavy (1¹/₂ pounds)—both attributes are assets to cutting fast and true. The saws are hand-sharpened and track a line quite well.

The crosscut saw had 14 points per inch;

the rip saw had 11 ppi. If you need something different, just ask. Wenzloff makes this saw in a variety of lengths and with 9 to 15 ppi. There also are a variety of wood species you can choose for the handle.

And if the price of the No. 9 is too much, Wenzloff also sells the saw as a nearly finished kit for \$110—you essentially finish shaping the handle and fit it to the blade.

In addition to the No. 9 saw, Wenzloff also makes pure custom saws and a halfback saw—a smallish panel saw with a short brass back. Wenzloff was tweaking the handle of that saw at press time; we'll give you an update on that saw and its performance in a future issue.

The Wenzloff saws rank up there with other premium makers, including Lie-Nielsen, Adria and Gramercy Tools. And, as a bonus, you can get your saw easily customized to your liking. I think you'll be as impressed with these saws as I was. **PW**

— Christopher Schwarz

For more information, circle # 167 on Free Information Card.



SPECIFICATIONS

Wenzloff & Sons No. 9 Backsaws

Street price: \$165-175 (\$110 in kit form)

Sawplate thickness: .030"

Brass back: .215" thick, folded on blade

Handle: 7/8" thick, bubinga

Performance: ●●●●○

Price range: \$\$\$\$

Wenzloff & Sons: 503-359-4191 or wenzloffandsons.com/saws/

FREE PROJECT PLANS

www.popularwoodworking.com

FREE PROJECT PLANS

www.popularwoodworking.com

FREE PROJECT PLANS

www.popularwoodworking.com

Woodworker's Supply[®] Inc.

Since 1972

"Where the experts buy their tools"

Request a **FREE** copy of our catalog, featuring the largest selection of woodworking tools and supplies anywhere!

woodworker.com/pw06

800-645-9292

When calling, mention code pw06

CIRCLE NO. 162 ON FREE INFORMATION CARD.

SPEND YOUR TIME ON THE FINISH — NOT THE CLEANUP!

Polyurethanes • Lacquers • Latex • Enamels • Stains

Professional Results!



Easy to operate!
Easy to clean!
Economical!

Circular spray pattern

The 118 SIPHON GUN includes a 16 oz. standard sealer jar... this system is ideal for storing different colors stains or paints for a quick - fast setup.

Available at:

- Lee Valley Tools Ltd. 1 800 871-8158
- Woodcraft Supply Corp. 1 800 225-1153
- Woodworker's Supply 1 800 645-9292
- Amazon.com 1 800 635-5140
- Rockler 1 800 279-4441

Email: sales@crittersprayproducts.com

CRITTER
SPRAY PRODUCTS

www.crittersprayproducts.com

CIRCLE NO. 112 ON FREE INFORMATION CARD.

STEVE WALL LUMBER CO.

Quality Hardwoods and Woodworking machinery For The Craftsman and Educational Institutions

Ash	4/4	Select	2.40	UPS	\$ 85.00
Basswood	4/4	Select	1.95		\$ 72.00
Birch	4/4	Select	2.75		\$ 89.00
Butternut	4/4	1C	2.30		\$ 77.00
Cherry	4/4	Select	4.90		\$ 110.00
Hickory - Pecan	4/4	Select	2.85		\$ 89.00
Mahogany (Genuine)	4/4	Select	3.90		\$ 100.00
Maple (Hard)	4/4	Select	3.15		\$ 96.00
Maple (Soft)	4/4	Select	2.30		\$ 79.00
Poplar	4/4	Select	1.75		\$ 72.00
Red Oak	4/4	Select	2.50		\$ 88.00
Walnut	4/4	Select	4.00		\$ 100.00
White Oak	4/4	Select	2.50		\$ 88.00
Cedar (Aromatic Red)	4/4	1C+Btr.	1.80		\$ 72.00
Cypress	4/4	Select	2.40		\$ 80.00
White Pine	4/4	F.G.	1.20		\$ 62.00
Yellow Pine	4/4	Clear	2.00		\$ 74.00

SEE OUR CATALOG ON THE WEB!

Above prices are for 100 quantities of kilndried rough lumber sold by the Bd. Ft. FOB Mayodan, NC. Call for quantity discounts. Other sizes and grades available.

Above prices are 20 bd. ft. bundles of clear kilndried lumber 3'-10" wide - 3-7' long (Random widths & lengths) Surfaced 2 sides or rough. Delivered UPS prepaid in the Continental U.S.

NOW AVAILABLE

Custom Made Raised Panel Cabinet Doors

4/4 Log Run Walnut Also Available
100 bd. ft. \$160 Exotic Lumber

STEVE H. WALL LUMBER CO.

BOX 287
MAYODAN, N.C. 27027
336-427-0637
1-800-633-4062
FAX 336-427-7588

Email: wood@walllumber.com
Website: www.walllumber.com

Send \$1.00 For Lumber Catalog
Prices Subject to Change Without Notice

CIRCLE NO. 154 ON FREE INFORMATION CARD.



watch. learn. buy. do.

Come to a **WOODWORKING EVENT** unlike anything you've experienced before!

Enhance your skills with over 100 hours of **FREE** classes!

- Master Clinics** presented by Delta, Porter-Cable and 3M SandBlaster, these FREE clinics are conducted throughout each day of the show
- Ask our Experts** sponsored by the Marc Adams School of Woodworking, featuring master craftsmen David Marks, Michael Fortune and Graham Blackburn
- Woodworking A to Z** presented by notable craftsmen, these FREE classes cover topics from Cabinetmaking to Sharpening and everything in between

Come to our event for paid seminars at every skill level, 100s of brands, factory reps, inventors, product samples and more. Everything you need to enhance your woodworking!

Visit www.thewoodworkingshows.com or call (800) 826-8257 for more information.

Proud Sponsors



CIRCLE NO. 163 ON FREE INFORMATION CARD.

The Toughest Glue On Planet Earth.™



Bonds hundreds of materials including wood, stone, metal, ceramic & more!
Incredibly strong & 100% waterproof!



1-800-966-3458 • www.gorillagluce.com

The Toughest Tape On Planet Earth.™



Extra Thick. Extra Stick.
New Gorilla Tape sticks to things ordinary tapes simply can't.

1-800-966-3458 • www.gorillatape.com

CIRCLE NO. 121 ON FREE INFORMATION CARD.

The Charles Plumley Inventory

Documentary sources teach us about traditional woodworking.

In my shop, tradition fills in where experience and education are lacking. So, I find it helpful to learn as much as I can about traditional woodworking. Studying 18th-century furniture is a great way to learn, but let's face it – I don't have any 18th-century furniture and the people who do don't want me steaming their joints apart so I can figure out whether the mortises were chopped or pared!

Period estate inventories offer the chance to explore 18th-century woodworking by analyzing the contents of period shops. The inventories won't tell us how to hold a mortise chisel, but they can help us form reasonable expectations for our work by revealing what our ancestors actually did and did not do with hand tools. For example: Were 18th-century craftsmen specialists who made the same things every day? How did they process trees into useable lumber? Did they use scrub planes for that? Were apprentices necessary for such work? The problem is, we don't generally know the answers to these questions. In this article, we'll examine one estate inventory and see what we can learn from it.

Inventories of one's worldly goods were taken to assist both heirs and creditors settle an estate. Adjacent to each entry, an approximate monetary worth was recorded. These values were subjective, varying certainly by region, but also depending on who recorded the inventory. The inventory here recorded the belongings of Philadelphia cabinetmaker Charles Plumley, who died in 1708. It's the earliest-known inventory of an American cabinetmaker. The two men who conducted the inventory were tradesmen themselves, and clearly very familiar with woodworking tools. It is one of the most detailed inventories of any 18th-century woodshop.



Photo by the author

Plumley probably used planes that looked like this reproduction from Pennsbury Manor. Its improbable shape is surprisingly comfortable to use.

About Charles Plumley

Plumley came to Philadelphia as a boy in August of 1682. He was probably in business for himself in the late 1690s. He died at age 34, leaving a wife and 2-year-old daughter. I suspect he lived on Front Street near Dock and Philadelphia's legendary tavern, the Blue Anchor. His father in law, Thomas Budd, owned the Blue Anchor and a row of 10, two-story houses known as "Budd's Long Row."

Type of Work

In furniture collector William Hornor's "Blue Book of Philadelphia Furniture" (1935), Plumley is listed as a "carver, turner, cabinet and chair maker." None other of the nearly 100 Philadelphia tradesmen active at the time

were identified by such an impressive collection of titles. At the time of his death, Plumley had several projects awaiting completion:

- 1 Walnut Table frame 1£ [pound]
- 2 black Carved Chair frames 18s [shillings]
- 7 sett Gum bedstead pillows [head boards?] 16s 4d [pence]
- 15 Sett [bedstead] Sydes and Ends 1£ 15s
- 1 Walnut cace drawers, not finished
- 6 Carved Maple Chairs not finished
- 1 parcell of wheel worke, not finished 1£ 10s

Additionally, we can deduce from the hardware in his shop, some of the other sorts of pieces he made.

Here we see the hardware for the beds he had in stock:

- 10 Long bedd screws 10s
- 12 short ditto [bedd screws] 6s
- And parts for clocks:
- 6 Clock Cace Locks 6s
- 3 pair box hinges Smooth filed 3s
- 4 pr. Clock Ditto [hinges filed smooth] 6s

by Adam Cherubini

Having no power tools, Adam relies on hand saws for the construction of his furniture. You can contact Adam at adam.cherubini@verizon.net.

Essential hardware for an escritoire or fall-front desk.

- 2 *Screetore hinges* 3s
- 2 *Screetore Joints* 1£ 9s
- 1 *Sett Screetore Locks* 8s

The desks were supported by folding metal braces (screetore joints?) attached to the sides of the upper carcass. Plumley may have used similar hardware when he built the “black screetore” in his bed chamber.

A “scutcheon” is an escutcheon or backing plate, used in conjunction with a “dropp” or brass ring. This sort of drawer pull was common in the William and Mary period (circa 1688-1702) and is one of the design elements used to define the style. A brass ring is a low-cost substitute for a cast pull.

- 35 *Old fashioned scutcheons* 18d
- 30 *old fashioned Damified Dropps [which means damaged – possible factory seconds]* 15s
- 15 *Large brass Rings* 15d
- 112 *Dropps* 28s
- 53 *Scutcheons* 13s
- 48 *Small brass Rings* .5d

Not all of Plumley’s furniture was for high society types. Snipe hinges were the cheapest type of hinge available and typically found on cruder, utilitarian pieces.

- 29 *pr. Snipe bills* 3d
- 12 *pr. chest hinges* 2d
- 30 *pr. Duftailes [hinges]* 10d
- 2 *pr. H hinges* 1s 6d
- 2 *pr Chest hinges* 1s 6d

Hardware was expensive, especially the locks. Plumley’s hardware was easily worth six months’ wages. His investment suggests a market existed in Philadelphia for clocks, desks, chests of drawers, small chests like dressing boxes (an 18th-century jewelry box for jewelry and makeup).

- 1 *Double Spring Chest Locks* 6s
- 18 *Outside box Locks* 10d
- 2 *small Chest Locks* 1s 6d
- 1 *Desk Lock* 1s 6d
- 4 *Sett Chest Draw Locks* 4s
- 4 *Dressing box Locks* 1s
- 3 *Dore box Locks* 5s

Finally, the furniture in Plumley’s home includes a dozen chairs, quite likely of his own making.

- 1 *black Cherry tree Chest Drawers* 2£ 10s
- 1 *black screetore* 3£ 5s
- 6 *black Caine Chairs* 10s
- 6 *leather Chairs* 8s 4d

Clearly Plumley was capable of performing the work of several trades. Though he was well equipped, Plumley’s tools and shop don’t seem exceptional. The wide variety of his work supports the theory that a little skill and a basic set of hand tools can go a long way.

Nature of Work

Plumley didn’t work alone. He had two indentured servants, Isaac and David. It appears these men were well outfitted with tools in Plumley’s shop. There is a common belief, especially among woodworkers reluctant to use hand tools (who are better known as scaredy cats), that servants or apprentices in early workshops did the brute work for the master. As you read the inventory, notice the quantity of the specialty tools we would usually associate with fine workmanship. Is there anything to indicate Plumley’s servants did all the brute work, while he alone did the joinery or finer tasks? Notice the values of the workbenches:

- 3 *Long Plaines* 2d 6d
- 3 *Jack Plaines* 1s 6d
- 3 *Smoothing plaines new* 1s 6d
- 3 *Smoothing plaines* 1s
- 3 *half upright Ditto [high angle smoothing plane?]* 8d
- 1 *Jointer Yellow Jaunders* 7s 6d
- 2 *Ditto beach [jointer]* 3s 9d
- 3 *strike blocks* 1s 4d
- 3 *Rabbitt Plaines* 10d
- 9 *OGs* 1s 3d
- 6 *belexions* 1s 2d
- 5 *handsaws* 5s 1d
- 4 *Tennant Saws* 4s 1d
- 3 *beam Saws* 2s 6d
- 3 *small saws* 1s 0d
- 33 *formers and broad Chisells* 0s 7d
- 3 *Old Paring chissells* 5d
- 1 *The best bench* 13s
- 1 *Ditto [workbench]* 10s
- 1 *ditto [workbench]* 7s
- 6 *glew potts wt 41 [lb.]* 2s 1d
- 6 *ffeneaireing Screws* 1s



Photo courtesy of The Colonial Williamsburg Foundation



William and Mary-style drop (pull) and escutcheon. This one is from Londonderry brasses.

This escritoire was made by Plumley’s contemporary, Philadelphia joiner Edward Evans, in 1709. Notice the number of drops and escutcheons used.

Modern Tools in 1700

Plumley had a variety of what I consider to be modern tools. “Strike blocks” were low-angle planes with short rectangular bodies used to trim joints. These planes are probably the real reason we call small, low-angle planes “block planes.” Plumley’s upright smoother is very likely his tooting plane. Half-upright smoothers must be what we would call “half-pitch” planes today. Bedded at 60°, half-pitch planes are halfway between “upright” and “common-pitch” 45° planes. It’s difficult to know if these were used as high-angle smoothers, or were fitted with one of the many “tooth-plaine” blades. Plumley had an impressive array of moulding planes including 22 hollows and rounds, ogees and bolections.

I was surprised to see the following two entries, which I am interpreting as concave and convex compass planes:

- 2 Rownd Smoothing Plaines
- 1 hollow ditto

When is the last time you saw a wooden concave compass plane? I’ve never heard of such a tool.

Stanley never made a high-angle smoother and its block plane was only marginally lower than the “common-pitch” bench planes. So the industrial revolution, for all its innovations, only reduced what had previously been



In this instance, “Snipe bills” are probably snipe hinges (shown at right), not snipe bill planes (shown above).

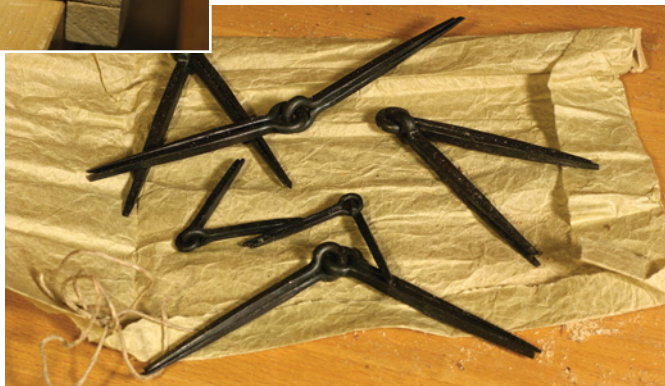

available to craftsmen. It appears Plumley had a greater variety of planes available to him in 1700 than were available 200 years later.

Materials

Plumley may have had as much as 10,000 board feet of pine and walnut. The quantity of lumber alone challenges the notion that 18th-century woodworkers cut down trees and had their apprentices convert the timber into useable stock. The Plumley inventory appears consistent with the John Head account book (google “John Head”+joiner); Period craftsmen bought sawn lumber much as we do today. It’s doubtful they did much “thicknessing” with planes. Rather, they very likely flattened their boards with their jacks and long (try) planes, then smoothed them as required.

There were other surprises as well, such as this one related to wood:

- 36.5 2 [inch] Mahogany Planks at 16 [d. per foot]

The price of this plank is more than eight times greater than walnut. Elsewhere in the inventory, the price of mahogany is comparable to walnut. It’s possible this particular mahogany was crotch or figured wood intended for veneer. Plumley certainly had the tools he needed for veneer work, including:

- 1 parcell of olive wood and other Veinarys 1£ 16s
- 1 Large frame saw 9s
- 1 Upright Smoothing plaine 8d
- 7 New Plaine Irons 10d
- 3 Tooth plaine Ditto 10d
- 7 plaine Irons 5d
- 2 Tooth Plane Do 10d
- 6 glew potts wt 41 [lb.] 2s 1d
- 6 ffeneaireing [veneering] Screws 1s 76 lb. of Glew 14d



Courtesy of Winterthur; Gift of David Stockwell

Plumley’s chairs may have looked something like this caned black walnut chair c.1720.

‘Traditional’ Hand-rubbed Finishes

I am of the opinion that period furniture was typically finished with little more than oil and/or a bit of wax. And that may be generally true. But there’s nothing like primary source materials to challenge our long-standing beliefs. In the Plumley inventory we see very expensive varnish and brushes to apply it. The fish skins, possibly shark, were known for their abrasive qualities and could well be the sandpaper needed to rub out the finish. But sharkskin, often called “shagreen,” was identified in other accounts and inventories in conjunction with cases that held silverware (especially knives). Skins of different sorts, often dyed green, were stretched over wooden frames to make small boxes. They could have used brick dust to rub out their finishes, or the lightly abrasive rushes in the shop may have been considered valueless and not inventoried. So were the fish skins sandpaper, or a decorative cover for a future knife case? Decide for yourself.

- 2 Quarts Varnish 12s 6d
- 4 pr fish Skins 2s 6d
- 1 [lb.] bees wax 1s 6d
- 2 New Varn[ish]ing brushes 1s

Things Forgotten

Equally as interesting as the many surprising items inventoried is the omission of items we tend to think of as necessities. Most glar-

ingly omitted are marking gauges. No marking or cutting gauges were inventoried. I really doubt they were absent from the shop. The woodworkers who recorded the inventory may have simply considered such small, shop-made items valueless. Also, no clamps were inventoried. Many woodworkers believe one cannot have too many clamps. Yet here there are none. Were there really none or were they skipped? I don't see clamps in other period inventories. At the very least, it seems to me that clamps are more helpful in shops where slow-curing glues and fasteners or dowels are used to produce joints. Clamps may have been used more to hold wood during shaping than for assembly. The absence of a considerable number of clamps points to this distinction in the methods of work and joinery. As you read inventories, sometimes what's not on them is just as interesting as what is.

Conclusion

Period estate inventories offer us an unvarnished look at the lives and work of 18th-century woodworkers. The Plumley inventory suggests craftsmen were capable of making a wide variety of items, worked with a number of different materials and finishes, and used sophisticated tools. There's no indication that their work was so laborious that "free" labor was required to be productive.

So herein lies an excellent starting place for any modern woodworker; here is the description of a successful and versatile shop, and a list of all the tools and materials required to operate it. Because this is past history, we know, given this shop and tools, what is possible.

Granted, it doesn't help us cut a perfect dovetail, but it does tell us perfectly serviceable dovetails can be cut under these circumstances. All that's left for us to do is to try.

I'd like to thank Jay Gaynor at Colonial Williamsburg, and curatorial intern Lois Stoehr at Winterthur for their diligent research efforts, which helped me bring this article to completion. Lastly and most importantly, I'd like to thank the *Popular Woodworking* readers who have responded positively to this sort of article. I promise to get back to woodworking in the next issue!

For more information on Charles Plumley and to view the full inventory, go to popularwoodworking.com and click on "Magazine Extras." **PW**

LOWEST PRICES UNBEATABLE QUALITY



DON'T SETTLE FOR SECOND BEST WHEN YOU CAN GET THE ULTIMATE PATTERN SET!

Including Our New Double Bearing Bit with a Huge 2" Cut length!

ONLY \$69

\$95 Value - WL-2032

- 1/4" and 1/2" Shank
- Multiple Cut lengths and Diameters so that you have the right bit for the Job
- Rugged Carbide Tips
- Replacable Bearing System

PRO CABINETMAKER 6 pc Door Set

- 1/2" Shank Router Bits
- 2-pc Rail & Stile (Roman Ogee)
- Drawer Lock
- 3 1/4" D Panel Raiser (Ogee) with UnderCutter
- Door Lip
- Reversible Glue Joint

ONLY \$119 set
\$175 VALUE
WL-2020-1



800-472-6950

ORDER 24/7

WOODLINE.COM

FREE STRAP CLAMP

8 Piece PICTURE FRAME SET

Perfect for making great looking picture frames. Bits can be combined to form complex mouldings or simple decorative frames.

OUR PRICE ONLY \$75 set
WL-2008
\$189 VALUE

CARBIDE

66 Piece

Master Woodworking Router Bit Collection

This may not be every bit you'll ever need, but it's close! Use this set to complete your collection!

WL 2066 1/2" Shank..... **\$189**
WL 2065 1/4" Shank..... **\$189**



PALAMINO Router Table

3-1/4" HP ROUTER WHILE SUPPLIES LAST

- Portable design for ease of use
- Quiet deluxe cabinet base
- Laminated 12 ply birch 1-3/16" ultra flat top
- Deluxe fence system
- Fits all routers with up to 3-1/2" diam. bits

ONLY \$239

REG \$295 + \$169 Router- WL-TAB2



FREE CATALOG 1-800-472-6950 **WOODLINE USA**
111 Wheeler St, LaVergne TN, 37086

Complementary Curves

Use your router to join wood along simple and complex curves.

If you rip a board in two, you can easily rejoin the pieces along the line of the cut. But you can't rejoin two pieces that have been cut along a curving line. Because of the material removed by the saw kerf, the contour of one piece will differ from that of the other.

You can visualize this more clearly if you think about routing a circle. The disk removed is smaller in diameter than the hole. The difference is twice the diameter of the bit you used. But suppose you did want to join two boards along a curved line. How would you go about it?

If the curve is a simple, fixed-radius one, all you need is a router and trammel. Cut the arc on one piece with the bit inside the radius, and on the other piece with it outside the radius. The two pieces should mate perfectly.

But that won't work for a sprung curve or an undulating curve. If the curve is very gentle, varying no more than about $\frac{3}{4}$ " from a baseline, you can shape the mating edges by guiding a router along a fence with the contour of the joint you want. I described this process as an edge-jointing technique in issue #137 (November 2003). It produces positive and negative copies of the fence contour.

Just be forewarned: The more curve you use, the less perfect the fit. The contour of one curve is offset from the contour of the other by the bit's diameter. When the curve is gentle, the contours of the two pieces should be sufficiently close to fit together nicely, forming a clean joint. Using a small-diameter bit minimizes the mismatch between contours.

Lay out your curve on the fence and cut it. Trace the curve onto the two workpieces. Remember that the second piece must be the reverse of the first piece, not a duplicate. Trim the workpieces shy of the lines.



Joining stock edge-to-edge along a wiggling, squirming line may be purposeful, but mostly it's for fun. Templates and a shop-assembled offset pattern bit are the secret.

Clamp the fence atop the first workpiece. Guide the router along it, trimming about $\frac{1}{16}$ " from the work. Then plant the second workpiece directly opposite the first, with a gap between them about $\frac{1}{16}$ " less than the bit diameter. Guide the router along the same fence – you haven't moved it – trimming the second workpiece and producing an edge on it that's a negative image of the edge milled on the first workpiece. The two boards should fit together perfectly.

As you set up, elevate both of the boards slightly so the router bit doesn't groove the

support surface (most likely your workbench). Both should be in the same plane, so the router remains square to the workpiece edges throughout both cuts. You also have to work out a setup that enables you to secure both workpieces.

If the curve you want is more pronounced, more radical, then you should turn to templates to rout mating contours. It's all about taking out the kerf, and templates give you a means of doing that accurately.

The Template-based System

In this system, you contour the mating edges of the workpieces guided by a pair of "working" templates. The drawing shows the sequence of steps you follow to make and use them.

In a nutshell, you lay out your curvy joint line on a piece of template stock then cut

by Bill Hylton

Bill is the author of several books about furniture construction and router operations. When he isn't writing about woodworking, he's doing it in his home shop in Kempton, Pennsylvania.

Photos by the author



A mildly curved joint line can be produced with a fence-guided cut. Saw the desired curve on the fence and the first workpiece. Guide a router along the fence, trimming about 1/8" from the sawed edge. The feed direction for this cut is toward the camera. (The work is blocked up on scraps so the bit doesn't cut into the benchtop.)



Without changing the setup, position the mating piece opposite the first. An approximation of the curve is sawed on its edge, and it's carpet-taped to scrap. The gap between the pieces is less than the bit's diameter. Make a pass in the opposite feed direction.



The seam is close to perfect – certainly close enough for a tight glue line.

it. Next, you stick that "master" template to another piece of template stock and rout. The resulting two curvy-edged pieces are your working templates.

Butt those working templates together and you'll see that they don't meet along the entire curved contour. Crest will touch hollow, but on the whole, it'll be a gappy fit. It's the kerf, of course. The larger the diameter of the bit you used to cut these two templates, the more prominent the gaps will be.

To get a perfect joint, you have to fill in that kerf, putting back the material that was wasted by the cutter. You do that as you use the templates to cut the mating workpieces. The trick is an offset pattern bit that you assemble using a standard straight bit, a bearing and a lock collar. The difference between the radius of the bit and the radius of the bearing is the offset. The offset you need in this instance must equal half the diameter of the bit used to make the working templates. By this means, you regain half the kerf from each mating workpiece. The resulting joint line fills in the center of the kerf.

Let's crack open this nut and pick out the contents. You make the master template first. This template needs to be about 6" longer than the workpieces, and 6" to 8" wide. The extra length enables you to begin and end cuts with the bit clear of the work.

I recommend using 1/2" Medium-density Fiberboard (MDF) for all the templates. Yes, MDF yields talc-like sawdust when you saw

1. Lay out master template.

2. Cut master template.

3. Make working templates.

Stick master template to blank for working templates. Rout with 1/2"-diameter pattern or flush-trim bit.

4. Cut work with working templates.

Cut workpieces with any bit/bearing combination that produces a 1/4" offset, guided by the appropriate working template.

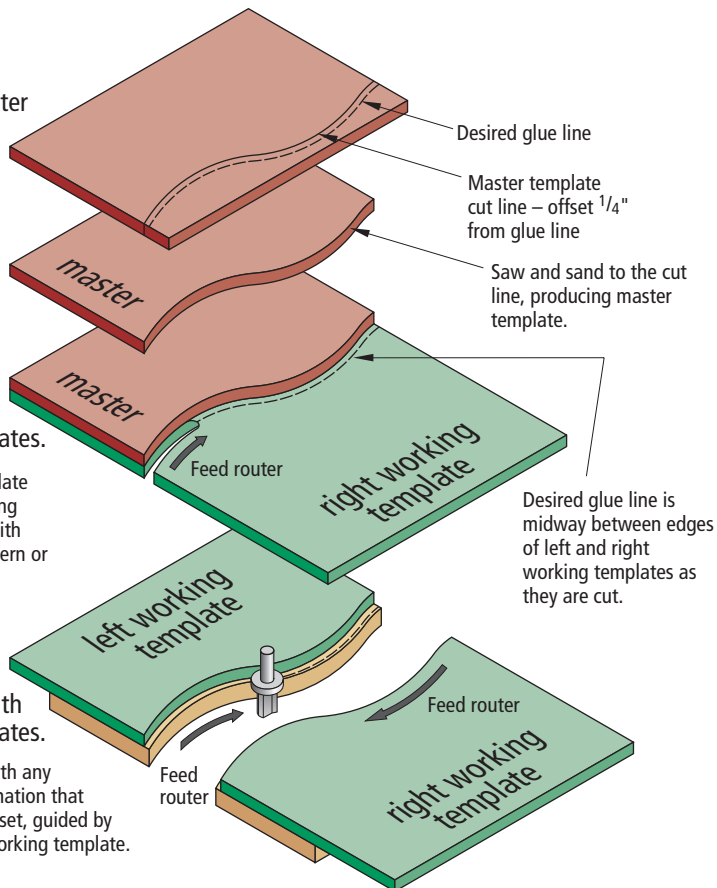

Cutting a complementary curve-edge joint in four steps

or rout it. But it has desirable characteristics: It is flat and has crisp edges that are easy to work with files and sandpaper. You can power through it in one pass with a router. It's cheap and it's widely available.

Near the right edge, carefully draw the joint line. It can be a sinuous curve, a series of straight lines and arcs, or whatever contour you desire. The only restriction is that none of the curves can have a radius smaller than that of the largest bearing or guide bushing you use. In this instance, that minimum is a $\frac{5}{8}$ " radius.

If the line you've laid out must be the exact line of the final joint, you have to draw a second line, offset to the left of the first. This second line marks the edge of the master template. To draw it, set a drawing compass to the offset distance and trace along the joint line with it. Pivot the compass around curves as necessary to maintain parallel.

The offset distance is half the diameter of the bit you intend to use with this template. The joint line is going to be the centerline of the kerf formed as you rout the working templates. And the offset distance is what you have to put back as you rout the workpieces with the working templates.

I use a $\frac{1}{2}$ " bit. It's a common size, and strong enough to make the cut in one pass.



If the final glue line must duplicate the drawn joint line, you have to offset the drawn line to delineate the guiding edge of the master template. Use a compass set to the "offset" dimension to do this. Then saw along the offset line to produce the "master" template.



You have to assemble your own offset pattern bit. Use the correct bearing: Its diameter equals the cutter diameter plus twice the needed offset. Slide the bearing onto the shank and capture it against the shoulder with a collar.

The resulting offset is manageable; the offset pattern bit you make up won't be wacky, with a huge bearing on a tiny bit. If you want to risk using a smaller bit for the initial cut, you'll have a smaller offset, which would be good. On the other hand, using a larger bit might be better for the initial cut, but it would mean having to deal with a larger offset. The $\frac{1}{2}$ " choice is a workable compromise.

You must choose the bit and figure the offset, but you don't have to offset the layout line. If the exact joint line isn't critical, just cut to your first-drawn contour. If you compare the master template to the completed joint, you'll find the joint is offset from the undulating edge of the template. But that hasn't been a concern in the work I've produced with this technique.

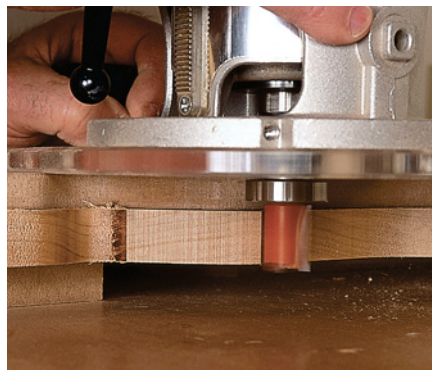

Here's a good match of bit, bearing and template. The template's thickness provides a measure of vertical adjustment and the bit is just long enough to work the edge.

With the line drawn, cut on the band saw or with a jigsaw, then sand the edge smooth. Clearly mark this as the "Master Template."

Make the Working Templates

You produce both working templates with a single cut. As the drawing implies, the blank for them ought to be at least twice the width of the master template. I'd make it wider than that; you can easily cut each one down, but you can't stretch them. The length should be about 3" longer than the workpieces, which makes it about 3" shorter than the master. The point here is to be able to start and end the cut with the bit clear, both when you make the templates and when you cut the workpieces.

Clamp, screw or stick the master template to the blank. Use a $\frac{1}{2}$ "-diameter pattern bit or flush-trim bit to cut along the contour of the master. The master goes on top if you use a pattern bit, and that makes it easier to follow the contour. You can see where the router has to go. With a flush trimmer, the master must be beneath the blank.

As you rout, keep the pilot bearing tight to the master template. A sharp bit, especially one with a shear angle to the cutting edges, can plow through $\frac{1}{2}$ " MDF in a single pass.



One pass along the "master" template creates the two "working" templates. Screw the blank to scraps so it's elevated above the benchtop. And clamp both sides so neither drops as the cut is completed! Screw the master to the blank. Use a straight pattern bit and make the cut in one continuous pass. The scrap under the router keeps it upright.

Keeping the router steady through the cuts is essential. Use an offset baseplate and its outboard knob to pull the router firmly against the master. In addition, you can attach a support block under the outboard sector of the baseplate. That will keep the router upright.

A goof doesn't necessarily mean you've got to start over, since the mistake will impact both working templates simultaneously. A gouge in one template is complemented by a bump on the other.

When the working templates are done, mark them clearly "left" and "right." On each, note the bit and bearing or bushing that must be used with it.

Routing the Workpieces

This is standard template-guided work. Use the same bit and bearing for both workpieces. Any bit-bearing combination that produces the necessary offset will do. If you've followed my recommendations so far, try using a 3/4" straight bit with a 1/2" shank and a 1 1/4" bearing. The bit is large enough to produce a good-quality cut finish without needing to use an excessively large bearing.

A word on making up this offset pattern bit. Most bit vendors sell bearings as well as bits. Look for the bearing with a 1 1/4" outside diameter and a 1/2" inside diameter. Buy a 1/2" diameter lock collar, which should come with an Allen wrench for its set screw. Slide the bearing onto the shank, right up against the cutter. Add the lock collar. Install the bit in the router, and you are ready to rout.

Before attaching the templates to the respective workpieces, transfer the curve to the work. Add the offset, of course. Saw away the waste, cutting just to the outside of the line marked on your work.

Attach the template to the work with carpet tape, hot-melt glue or even screws. Clamp the assembly so it can't shift as you rout, elevating it as needed so the bit doesn't cut into your benchtop.

Be wary of the interplay of the joint contour with the grain of the workpiece. It is very easy to chunk the edge when routing across the grain. Perhaps you've already experienced that. As you feed the router along the template, the tool jerks and you hear a scary CRACK! You look at the cut, and there's a chunk missing from the edge. Perhaps the work has a piece split off.



Saw the rough contour on the work, so the template-guided router is only trimming. Lay the template on the work and trace the line using a washer measuring 1/4" from rim to bore. Saw to the outside of the line.

When routing obliquely across the grain, you always want to be cutting "down" on it. It's like rubbing your hand across a rug. Move your hand one way and you raise the nap. Move it the opposite way, and you lay it down. As you rout, you want to be laying down the nap, not raising it.

If you faithfully observe feed-direction rules, you're always feeding the router against the bit's rotation, thus moving your hand-held router roughly counterclockwise. Routing a curve that sweeps back and forth across the grain presents a dilemma, because on roughly half the curve you'll be routing against the direction of the grain.

You'll have to violate one rule or the other. I opt to violate the feed-direction rule. Before beginning the cut, I look at the contour and the wood grain, and I pencil some arrows on the template to remind me which sections to rout in the "correct" direction and which sections to climb-cut. Then I switch on the router and cut.

If you've never done cross-grain routing, it's best is to start with mild curves and get experience with the dynamics. As you progress to steeper slopes and tighter curves, you'll be better prepared to deal with the difficulties these contours present.

Routing the mating edges is most of the battle. What follows is a simple, standard edge glue up. **PW**

Stick the template to the work with screws or carpet tape, block the sandwich up on scraps, and guide the router along the template edge, following the direction arrows. An offset baseplate on your router helps you balance the tool and pull the bearing tight to the template throughout the cut.

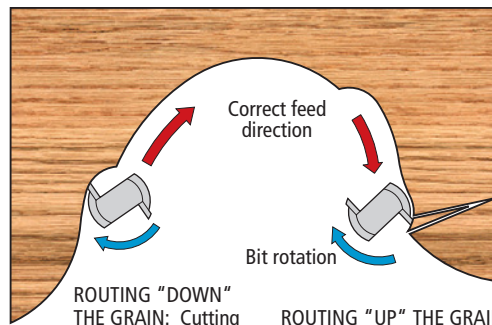

ROUTING "DOWN" THE GRAIN: Cutting edges sweep down on wood fibers, slicing them cleanly

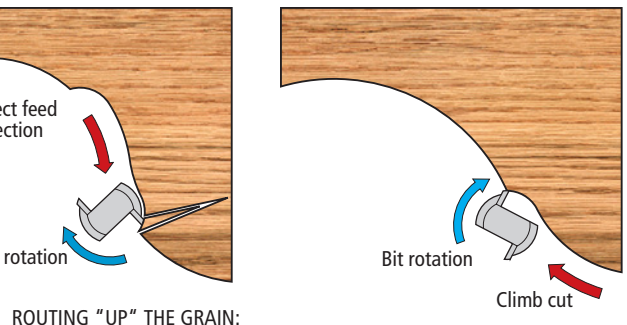

ROUTING "UP" THE GRAIN: Cutting edges sweep up under wood fibers, chipping their ends, sometimes splitting out chunks

CLIMBING THE UPHILL SECTIONS: Cutting edges sweep down and in on wood fibers

Avoiding tear-out

Workholding Strategies

Your workbench's vise isn't the only way to secure your workpieces.

Holding a cabriole leg for shaping can be a challenge if you use your bench vise alone. I clamp the leg in a pipe clamp then secure the clamp in my bench vise.

Learning to use hand tools opens a whole new realm of woodworking possibilities. Planes, saws and chisels give your work fine details that can't be matched by any machine. The narrow pins of a dovetail joint, the crisp surface texture from a handplane and the precise, piston fit of a drawer all speak of fine craftsmanship. They say, "This piece is handmade."

An important part of using hand tools is having a sturdy workbench and an assortment of stops, clamps and jigs for holding the work securely. While there are a number of expensive benches and accessories available for holding the work, you can also get set up for using hand tools without spending a small fortune. The keys are to construct a few simple fixtures and be creative in the manner you use your clamps.

Start with a Sturdy Bench

Planing, sawing and chiseling all push and pull on the workpiece; a rock-solid, heavy workbench that will resist the pushing and pounding is an essential part of successful hand-tool processes. Yet you don't need to break your woodworking budget to get set up with a sturdy bench; the best workbench is one that you make yourself. Although you're sure to find plans for a number of great workbenches, you don't really need anything elaborate. In fact, my own workbench is quite simple.



Your workbench is your most important workholding tool. It should be sturdy, massive and large enough to handle cabinet-sized work. Resist the urge to make your bench too high – that will make handplaning difficult.

It's just a thick, laminated top that is supported by a strong, rigid base that resists racking as I plane.

I laminated the 3"-thick top for my bench from maple. I saved a lot of money by purchasing second-quality lumber from a local furniture factory. The maple was culled because of the intermittent streaks of dark color and an occasional knot. Of course these small, natural defects in no way limited the use of the lumber for a workbench.

The base of the bench is also constructed of large stock joined together with mortise-and-tenon joints and steel rods to keep it stiff as I'm planing. The resulting

bench is massive, heavy and very sturdy – just what's needed when chopping dovetails or shaping the curves of a table leg.

If you're going to make a bench of your own, the most important dimensions are the bench height and the size of the top. Pushing a handplane across a wide board requires that you bend at the knees and push with your upper body, not just your arms. Resist the temptation to build the bench too high. For furniture hand work a top that measures 2' x 8' feet is ideal. This provides plenty of support for even the wide sides of a chest of drawers or the long sides of a tall case clock.

by Lonnie Bird

Lonnie is the author of "The Complete Illustrated Guide to Using Woodworking Tools" (The Taunton Press) and teaches woodworking. You can learn more about his classes online at lonniebird.com.

Add a Vise

To hold stock during layout and sawing I typically use the large iron vise I mounted near the corner of the benchtop. A large vise is undoubtedly the most important bench accessory that you can own. When you place work in a vise it not only leaves your hands free, it secures the stock to the heavy bench so that it becomes immobile while you work it. When laying out and sawing the dovetails on large casework, I use large wooden handscrew clamps to secure the portion of the work that extends beyond the jaws of the vise.

A large vise also provides a place to secure other workholding clamps, jigs and accessories. For example, when shaping and sculpting the curves of a cabriole leg I place the leg in a clamp and secure the clamp in the vise.

Because I constructed my bench at optimal planing height it is often too low for carving. To raise the carvings to a comfortable height I use a stand that is secured in the vise. I use quick-release ratchet-style clamps to secure the carving to the stand.

Holding Work For Planing

After milling stock to size with a jointer, planer and table saw, I smooth the surfaces with a handplane to remove the tell-tale machine marks. Although I sometimes use the vise to hold the workpiece, especially when planing the edges of small stock, I most



Securing wide workpieces using your bench vise alone can prove troubling – the vise’s screws limit how much you can grab securely. However, with the help of a handscrew clamp secured to your workbench, you can clamp almost any width.



The drop-down stop at the end of my workbench is a remarkably effective way to secure boards for planing. The ability to adjust the stop allows me to plane thin or thick stock with ease.



The drop-down stop can be used with other workbench accessories to clamp other challenging parts. Here, a V-block and wedge allow me to clamp a long, narrow piece on edge for planing.



Planing thin stock can be difficult. I tap a couple escutcheon pins into a piece of plywood and brace that against my drop-down stop. The heads of the pins are just high enough to secure the work.

often use the drop-down stop that I attached to the end of the bench. This simple device is just a strip of $\frac{3}{4}$ "-thick plywood that's attached with hanger bolts. (Hanger bolts have a machine thread on one end and a wood screw thread on the opposite end.) The plywood is slotted to allow for quick adjustments to the height of the stop;

simply loosen the wing nuts and slide the stop upward into position to accommodate the stock thickness. After planing, simply loosen the wing nuts and drop the stop out of the way. You've probably seen bench dogs used for holding stock when planing; one dog fits into a row of holes bored into the benchtop, the corresponding dog

is mounted on the movable jaw of the vise. While I like bench dogs for some tasks, handplaning all of the stock for a large piece of case-work is time consuming, and the bench dogs slow down the workflow because the vise is opened and closed each time the stock is repositioned or swapped out for the next piece. In contrast, the use of a drop-down stop can be a real time-saver.

There are several methods for holding stock on edge for planing. The easiest solution is to use the drop-down bench stop. To steady a narrow workpiece on edge you can slide it into a V-block clamped to the bench near the stop. The wedging action of the tapered jaws of the V-block will prevent the workpiece from tipping as you push the plane over the narrow edge. Wide stock can be placed in the vise; this will lower the position of the workpiece to a more comfortable height for planing. If the workpiece is long, such as the stile of a tall corner cabinet, I'll secure the opposite end with a large handscrew clamp.

Sometimes I'll band saw my own veneer for small boxes or drawer fronts. Holding the thin veneer as I smooth away the band saw marks can be a challenge. One solution is to use a pair of small brass nails or escutcheon pins as a stop. I don't really want nail holes in my benchtop so I drive the pins into an offcut of plywood instead. Then I position the plywood against the drop-down stop. To prevent the plane from striking the pin I drive the head of the pin slightly lower than the thickness of the veneer.

Plywood is also useful for holding drawers when planing them to fit. Fine, inset drawers are constructed the same size as the drawer opening. After assembly, each drawer is painstakingly handplaned to fit its opening.



Fitting traditional drawers typically requires you to plane the side to fit the drawer's opening. But clamping a drawer in your bench vise can wrack it, destroying the joints at the corners. A scrap of plywood and a couple clamps can be rigged up to effectively hold almost any drawer.

Placing the drawer in a vise to hold it while planing would rack it and cause it to break under the severe stress. Instead, I suspend the drawer over the edge of the bench on a piece of plywood that has been secured to the benchtop. The plywood holds the drawer securely without the slightest risk of racking and damaging the drawer. After fitting, the drawer bottom is slid into place in the bottom groove.

Octagonal chair legs and bed posts can be easily secured for planing by cradling them in a V-block. Another method that works well is to first secure the square portion of the post in the vise. As you push the plane with one hand, use the other hand to support the post and pull it upward against the sole of the plane.



Here's one way I shape octagonal parts: I secure the square section in my bench vise and plane the shape with one hand pushing the plane and the other supporting the stock below.

Shooting Boards

A shooting board is a shop-made fixture that supports both the plane and the workpiece. The shooting board has two stops; one supports the workpiece while the second stop rests against the front edge of the bench.

You can also construct shooting boards for miters but they really only work well for planing flat stock. Because I mostly miter mouldings, I find it easier to plane the mitered surface freehand. I place the moulding in the vise and use a small, low-angle block plane to remove a shaving or two from the end-grain surface of the miter before fitting the parts.

Holding Work For Sawing

Sawing dovetails is precise work; you'll get the best results if you keep the stock from flexing as you push and pull the saw. Therefore, it's best to keep the workpiece close to the jaws of the vise. As I mentioned earlier, I'll supplement the vise with a large handscrew clamp when sawing wide boards.

To accurately saw the shoulders of a tenon I use a bench hook. The bench hook is a simple bench accessory that is invaluable when sawing and planing tenons. Like the shooting board, the bench hook has two stops: one to hold the work and a second one that braces the fixture against the edge of the workbench.

Finally, consider a pair of holdfasts. These large steel hooks are incredibly useful workholding tools. They slip into round holes bored into the top of the bench and are wedged in place with a couple of blows from a mallet. To release the hooks you simply strike the back of the shaft. Holdfasts grip the work surprisingly well, they're quick and easy to use, and once you have a pair at your bench for a while you'll discover how versatile they are. **PW**



A shooting board can trim parts to length in a controlled fashion with the assistance of a bench plane. Hold the work against the fence with one hand and push the plane with the other.



Bench hooks are constructed much like shooting boards but are used to secure work for sawing. They are remarkably accurate and safe.

WOODWORKING ESSENTIALS

BY DAVID THIEL

CHAPTER

6

Casework Construction: Cabinet Hardware

Whether your casework is a bookcase, kitchen cabinet or highboy, the hardware you use to prop up the shelves, hang the doors or make the drawers slide smoothly can make or break the look and function of the finished piece.

We want to focus on three categories in this chapter: drawer slides, door hinges and shelf supports. Then, we'll use a little space at the end to talk about some specialty hardware.

Drawer Slides

For many woodworkers who build traditional 18th- and 19th-century furniture the topic of drawer slides is one that's handled on the table saw. These pieces of furniture use wooden drawer runners and guides that are frequently built into the framework of the piece itself. While these are appropriate and functional, that's not what we're going to talk about here. We're talking about mass-produced metal ball-bearing drawer slides.

Metal drawer slides are two-part hardware, with one part mounting to the inside of the cabinet and the mating part mounting to the drawers. How the two parts interlock and move is specific

to the manufacturer and design, but they all use the same concept.

Drawer slides take up some space in the cabinet and that will affect the overall storage space available in the drawers and cabinet. In general you'll lose 1" in width to allow for the drawer slides. But different slide designs will

offer different spacing and locations, which we'll talk about further.

Drawer slides can be grouped into two large sub-groups: side mount and under mount. Within these two groups slides can be either three-quarter or full extension. Full-extension slides allow access to all of the drawer's interior,



Putting drawer slides on in the correct location takes a certain amount of careful calculation. Most slides, however, allow a certain amount of adjustability, which provides some room for forgiveness.

allowing the full drawer box to open past the front of the cabinet. Slides break down even further by weight limit and design. There are truly too many types of slides to discuss all of them here, so we'll hit the most common styles and discuss some mounting tips.

■ Side-mount Slides

Side-mount drawer slides constitute what could be called traditional metal drawer slides. They've been around for a very long time and have generally provided good service.

Usually attached near the bottom of the drawer side, these slides are available in three-quarter or full extension.

Three-quarter-extension slides are most commonly available in 75- to 100-pound capacity and are used for lighter-duty applications such as small desk drawers and clothing drawers.

Full-extension slides are available in a wider selection of weight capacities, ranging from 100 to 500 pounds per pair. These heavier-duty full extension slides are often used for filing cabinet drawers, silverware drawers, media storage and computer components.

In choosing the correct slide drawer for your application, the weight load and required extension should be your first two factors to consider.

The next factor is the length required. Drawer slides are sized in 2" increments starting at around 12" long and usually topping out at 22" long. If your drawer depth is 15" and you are using a three-quarter-extension slide, you would most commonly use a 14"-long drawer slide. If, however, your case has enough depth to allow a 16"-long drawer slide, you can allow the slide to extend beyond the rear of the drawer box and gain a little extra extension on the drawer.

When using full-extension slides you should try to use the longest possible drawer slide to match the drawer. Otherwise you will be defeating the purpose of the full-extension slide.

Side-mount slides most commonly require 1/2" of clearance on either side of the drawer to accommodate the slide members. There are some models that require less space, but these are special application slides. Top-to-bottom spacing allowances will be determined by the type of slide used. Most side-mount slides allow the drawer to slide straight in and out of the cabinet, allowing nearly full-height drawer sides and maximized storage space.

Because side-mount slides can be mounted anywhere on the side of the cabinet and drawer box, both the drawer member and the cabinet member offer elongated slots to adjust for height and depth. This offers a fair amount of forgiveness when attaching the drawer slide members. But don't confuse this extra adjustment with a license to be haphazard. Aligning the slides accurately will make the process much more convenient and keep you from becoming frustrated.

Using spacing templates when installing slides will help you evenly space the slides from top to bottom. More important, spacers will help you make sure that the left and right drawer slides are evenly spaced in the cabinet so you don't end up with a "leaning" drawer.

After the drawers are properly fit and adjusted in the drawer space, go back and install the permanent screws in both the cabinet and drawer members. As the drawers are used over time, the slides can shift on the screws in the slotted holes, changing the fit of the drawer.

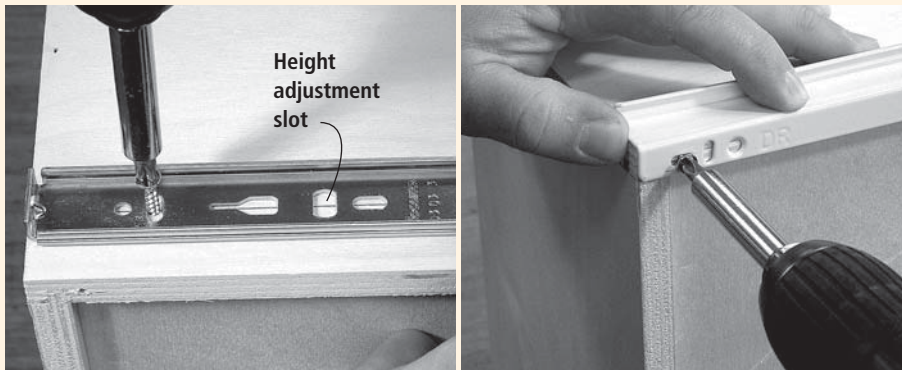

A side-mount slide (full extension) is shown at the left. At right is what is referred to as an under-mount slide. The misnomer on the under-mount slide is that it fastens to both the side and bottom of the drawer (providing excellent support). Both slides mount with the front edge of the slide flush to the drawer box. On the side-mount slide, the height can be adjusted using slotted holes in both the drawer slide and cabinet member. For the under mount, height adjustment is only available on the cabinet member. Notice that the under-mount slide has a "DR" embossed on the member. That stands for Drawer Right and can be a very helpful reminder during installation.

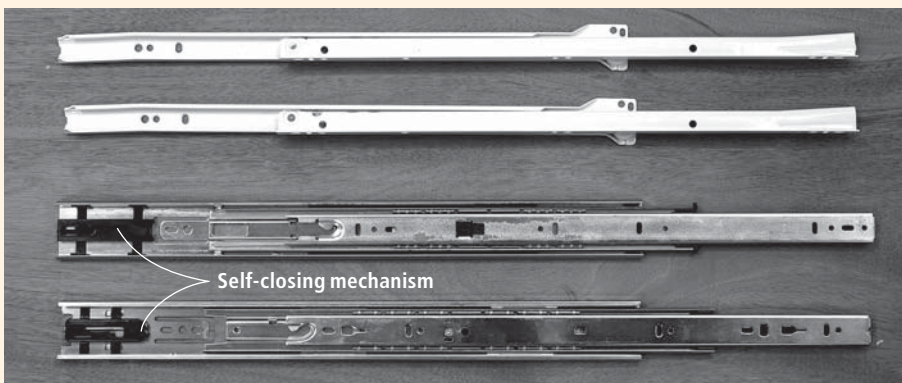

Shown above are under-mount and side-mount drawer slides. The top two are technically under-mount slides, attaching below the drawer side, though they wrap around the side and bottom. Both are three-quarter extension, with the top rated for 75 pounds and the second rated at 100 pounds. The lower two slides are side-mount, full-extension slides that are self closing, meaning the last couple of inches of travel when closing is automatic. They are also rated at 100-pounds capacity. Although from two different manufacturers, they differ only slightly in design.

■ Under-mount Slides

There are also specialty under-mount slides that mount below the drawer bottom (usually a single slide mounted in the center of the drawer) allowing full-width drawers with no visible hardware. These are frequently more expensive and involve more complicated mounting procedures, including changes to the way the cabinet itself is constructed. You should be aware of them, but we're going to look at the more common under-mount enamel-coated slides that mount at the bottom of the drawer sides.

These lighter-duty slides offer good support by wrapping around the bottom

of the drawer side (using the drawer itself as support) rather than relying on screws fastened into the sides alone.

I mentioned that these slides are enamel coated. These allow the slides to be made in a variety of colors, including white, almond, brown and black, rather than just bare metal. Many people find this appearance more appealing. Beyond the look, the enamel coating also serves to deaden the noise created by the slides as the drawer is opened or closed.

Because these under-mount slides mount to the bottom of the drawer side as well as to the side, there is no height adjustment on the drawer members

of the slides. This makes it even more critical to get the spacing of the cabinet member accurate.

Speaking of spacing, these slides also require a $\frac{1}{2}$ " gap on either side of the drawer box to allow room for the slides. In addition, the manner in which the drawer and cabinet members interlock requires you to lift up the drawer to remove or install it in the carcass. This means that the drawer sides have to be shorter than the opening by as much as $1\frac{1}{2}$ " to allow for that clearance. Because you have to allow this extra space, that means slightly less storage space in each drawer when using these slides.

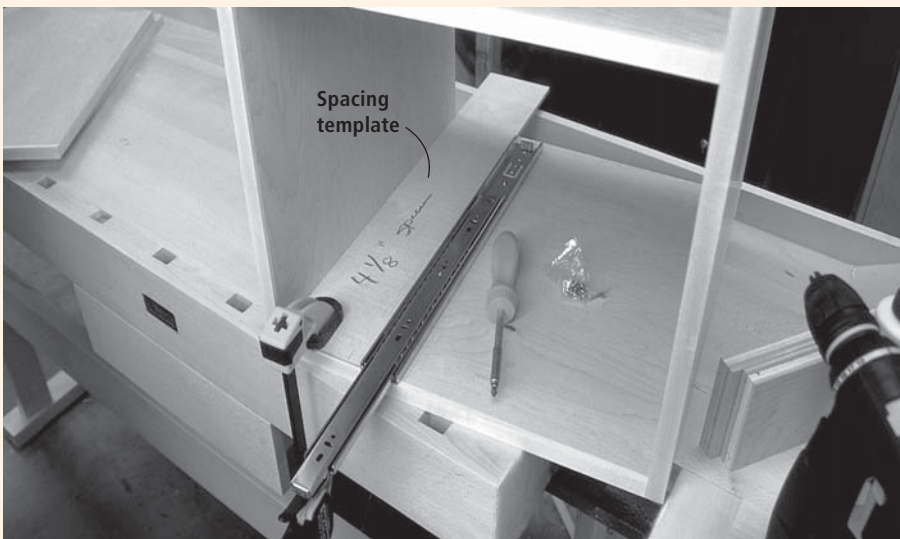

A spacing template makes getting the drawer slides mounted to the cabinet easier and helps ensure that you won't need to do as much adjusting to fit the drawers.

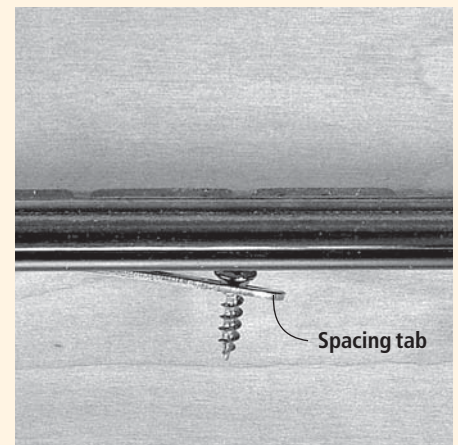

Even with careful measuring, sometimes your drawer ends up more narrow than planned. Some slides offer an adjustable (bendable) tab to space the slide (and drawer box) farther away from the cabinet's side for a tighter fit.

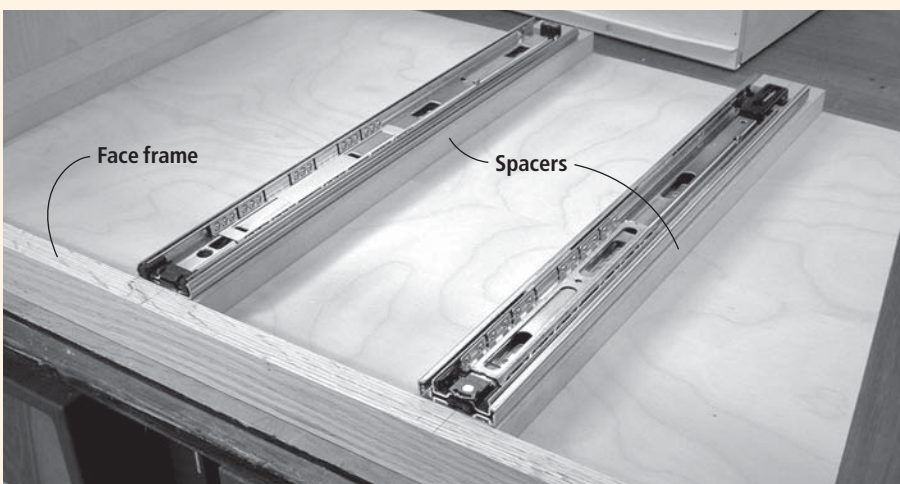

Face frame cabinets have recessed sides on the inside requiring spacers behind the slides to bring them flush to the inside edge of the face frame member.



Even if the slide isn't equipped with adjusting tabs, slight adjustments in width are possible. Pieces of veneer tape can be used as shims for a tighter fit. Leave the shims oversize while fitting, then trim to size to hide behind the slide.

Hinge Types

Unswaged Butt Hinge

Requires little work, but presents an unattractive gap between door and frame.

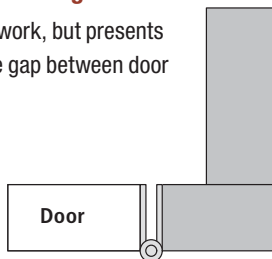

Swaged, Mortised Butt Hinge

Shown in two orientations, this hinge minimizes the gap between the door and hinge, but requires the hinge be mortised into the door and frame pieces.

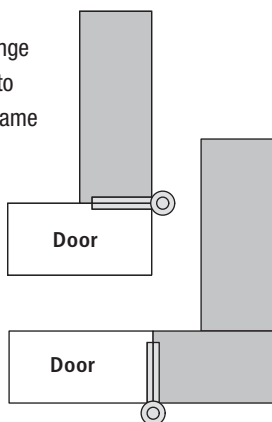

Non-mortise Butt Hinge

By using interlocking hinge leaves, the gap is reduced to $\frac{1}{16}$ " and requires no mortising.

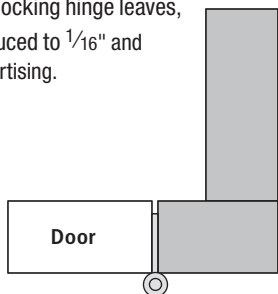

Lipped Inset Hinge

This wrap-around hinge allows lipped doors to recess within the space of the cabinet frame with little work.

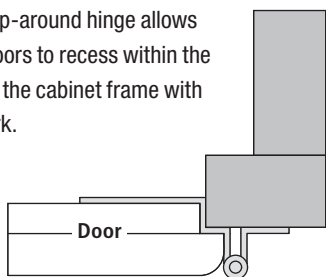

A mortised hinge – the bane of many a woodworker. To avoid an unsightly gap between door and cabinet frame the hinge leaves must be set into the door and frame. As you can see, this requires a three-sided shallow recess. While a router and special jig can make the mortise easier, a chisel is still required.

Door Hinges

As with drawer slides, door hinges is a vast topic to try to tackle in a small area. So we'll focus on the most common types and actually break them into two areas: the more traditional butt-style hinge and the less discussed (but very useful) European hinge.

■ Butt Hinges

Butt hinges can be used to connect doors to face frame or frameless cabinets (see above and left) and there are hundreds of different styles and permutations. They include swaged, unswaged, mortise and non-mortise hinges and a variety of lipped/overlay/inset hinges for special applications.

Let's talk about the basic hinge first. The hinge is supposed to do two things: make the door swing and allow the door to fit the cabinet in an attractive manner. Swinging is easy; the fit is something else. Butt hinges are sold swaged and unswaged. The two variants are shown in the illustrations at left. An unswaged hinge is slightly less expensive, but if mounted without the benefit of mortising can leave a rather unsightly gap between door and cabinet. If mortised into the pieces the gap will shrink, but will not close to what I would consider acceptable proportions.

Swaged hinges will leave about a $\frac{1}{8}$ " gap between the door and case if used without mortising. Better, but still not



A wonder of technology – a non-mortise hinge. The leaves of the hinge are built to interlock when closed leaving no more than a $\frac{1}{16}$ " gap. Even better, all you have to do is screw the hinge in place. Wonderful.

preferable. Mortising will allow an airtight fit, but will require time with a router and chisel, or just a chisel. It can also be tricky to get the mortise the perfect depth to accommodate the hinge leaves.

Which brings us to non-mortise hinges. A recent addition to the hardware world, they're quickly gaining acceptance for their ease of use and finished appearance. These hinges have interlocking leaves that allow the door to close leaving just $\frac{1}{16}$ " gap between door and cabinet. That's an acceptable gap requiring only that you screw the hinge in place.

These non-mortise hinges are available in a number of styles to fit many different door profiles. Speaking of which, standard hinges wander into a dizzying array of choices when they become "wrap around" hinges. These hinges are designed to accommodate inset, offset, lipped and overlay doors. Shown at left is only one type of option in this area. Your best bet is to match the door profile to the hinge. And I mean match. Fit the hinge to the door. I can't count how many times I've purchased what I was sure was the correct hinge, only to head back to the store.

With all these hinges I recommend drilling pilot holes to accurately center the screws in the holes. Otherwise a slight shift of the hinge can throw the door alignment out of whack.

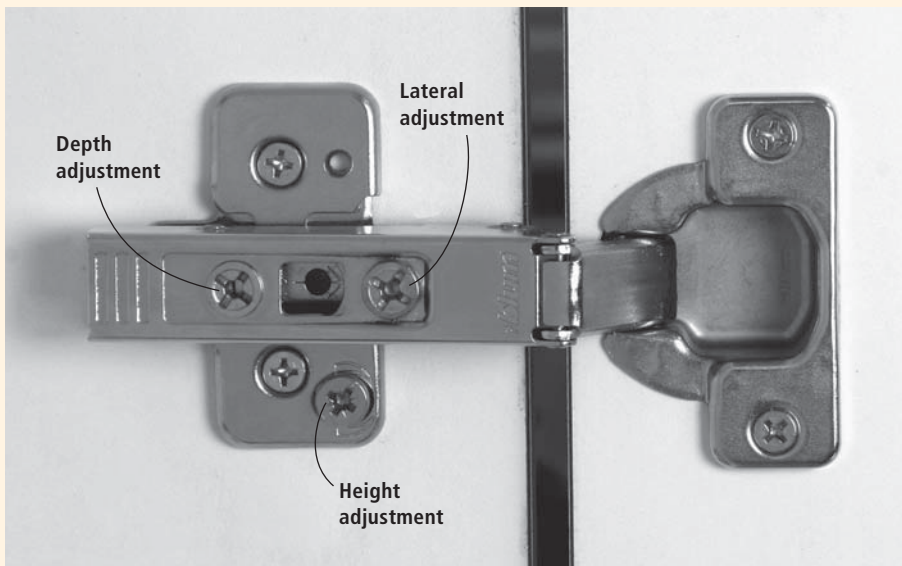

European hinges are adjustable in three directions after installation. In this hinge, two screws lock the position of the base plate, and the height adjustment screw acts as a cam to move the hinge up and down. The other adjustment screws are also cams. The depth adjustment moves the hinge toward or away from the front of the cabinet. The lateral adjustment moves the hinge to the right or left when facing the cabinet. These adjustments allow you to fine tune the fit of the doors, but the doors and their openings must still be carefully made. You won't be able to make an obtuse door square, or a small opening larger by adjusting the hinge.

■ European Hinges

European concealed hinges are quite a bit different from butt hinges, and the differences in design and function can be bewildering. Once you understand how they function, the choices you have, and a few quirks, you can use them to quickly and consistently hang doors on both face-frame and frameless cabinets.

The biggest difference is that no part of the hinge is visible on the outside of the cabinet. A base plate attaches to the inside of the cabinet, or to the face frame. The hinge arm fits in a 35mm diameter hole bored in the back of the door. Different thicknesses of base plates and different types of arms allow you to have the doors inset within the opening, or partially or fully overlaying the front of the cabinet box.

The trade-off for the speed and adjustability of concealed hinges is twofold. They take up some space on the inside of the cabinet, and they don't open as far as butt hinges. Instead of swinging freely, European hinges will stop opening at 105° to 176°.

The big advantage to these hinges is that you have built-in adjustments as shown in the photo above. After you hang the doors you can move them in or out, up or down, or right and left by turning a screw. You still need to work carefully to get the doors and their openings square and the correct size, but the ability to adjust can be a lifesaver.

Most retailers sell prepackaged combinations of plates and arms designated by the application and type of cabinet. They also have pretty good instructions

either in the packaging or on their web sites. Successful installation is mostly a matter of placing the holes exactly where you want them, and making sure they are the right diameter and depth.

One issue with European hinges is that they are manufactured in metric dimensions. Laying out the work and following instructions is faster and easier if you switch to working with millimeters. Converting from fractions to millimeters and using the nearest "inch size" bit instead of the correct metric one can lead to problems. It's a lot like working on a car that uses metric fasteners – a 1/2" wrench doesn't really fit a 12mm nut,

and a 35mm diameter hinge cup doesn't really fit in a 1 3/8" diameter hole. You don't have to work with millimeters for your entire project, but a metric tape and rule will help you immeasurably.

The location of the hinges and plates vertically is the one variable that isn't locked in. Between 3 1/2" and 4" from the top and bottom of the door works well in most cases. If you are working on a project with varying door heights, it's easiest to place the hinges consistently on the doors, and locate the base plates in the cabinet boxes to match.

The base plate holes are always 32mm apart, and 37mm in from the front edge



Use a jig – either a shop-made one or a commercial jig as shown – to precisely locate the holes for the hinge base plates. This jig from EZ-Mount (ez-mount.com) lips on the cabinet front and gives a 3" offset from either the top or bottom of the cabinet. The jig allows you to hold the hinge plate accurately in the jig while using a Vix bit to pre-drill the screw holes. Different jigs are required for offset versus overlay hinge locations. The hinge type is imprinted on the plastic of the jig to avoid mistakes.

of the cabinet for overlay doors. With inset doors, add the thickness of the door to 37mm to locate the base plate holes. These holes need to be precisely located so it makes sense to use a drilling jig as shown on the previous page. You can buy one, or you can make your own.

The hole in the back of the door is generally 35mm in diameter, and is best drilled with a Forstner bit. Before drilling a real door, check your drilling setup on some scraps. It's important that the depth of the hole is correct, and the distance between the hole and the edge of the door determines either the amount of overlay or the gap on an inset door. You can use a drill press (shown below),

set up with a fence so the edge-to-hole distance is consistent, or use a jig and a hand-held drill.

Because the hole for the hinge cup is close to the edge of the door and relatively deep, a moulded profile on the edge of a solid wood frame and panel door may intersect the hole. Run the profile on some scrap material and drill a test hole to make sure this doesn't happen. Many router bit manufacturers make low-profile bits for this application.

If you're only hanging a few doors, you can mount the hinge arms in the doors, place the door next to the opening, and mark the centers for the base plate holes directly from the door. If you have a proj-

ect with many doors, make or set a jig to locate the holes in the cabinets. You can then mount the baseplates in the cabinets and the hinges in the doors.

Once you have both pieces of hardware in place, the end of the hinge arm clips on to the base plate as shown below. Start by locating both hinges in the notches at the front of the plate and push the arm back until it snaps into place. If they don't quite line up, you can loosen or change the height-adjustment screw to get them to snap on.

While European hinges are designed to be used in frameless cabinets, you can also use them with traditional cabinets that are built with face frames. Special baseplates are made for this application, or you can add some wood behind the face frame to provide a flush surface to mount standard base plates.

When you have all the doors attached to the cabinet boxes, you can use the adjustment screws to get even gaps between doors, and an even overlay at the edge of the cabinet. I generally set the height first, then the depth and make certain that the door swings freely. Once this is done, adjust the doors side to side. You may need to go back and readjust to fine-tune the finished look.



A drill press with a fence and the right size Forstner bit consistently locates the holes for the hinge cups. A rabbet on the bottom edge of the fence will keep chips from building up that would hold the edge of the door away from the fence. Adjust the fence and drill test holes to get the hole the right depth and distance from the edge of the door.

When the fence and depth stop are set, use a small square to mark the location of the center of the bit on the fence. Measure from that point both left and right and mark the distance from the edge of the door to the center of the bit. When drilling the holes in the doors, line up each end of the door with the mark you made on the fence. When you mount the hinge arms in the holes, make sure that the flat area of the arm is perpendicular to the edge of the door.



If all the parts are placed in the right locations, using European concealed hinges will let you hang a lot of doors very quickly. The hinge arms clip into place on the baseplates. If the alignment is slightly off, loosen the height-adjustment screw on the baseplate to allow the hinge to clip on.

Shelf Supports

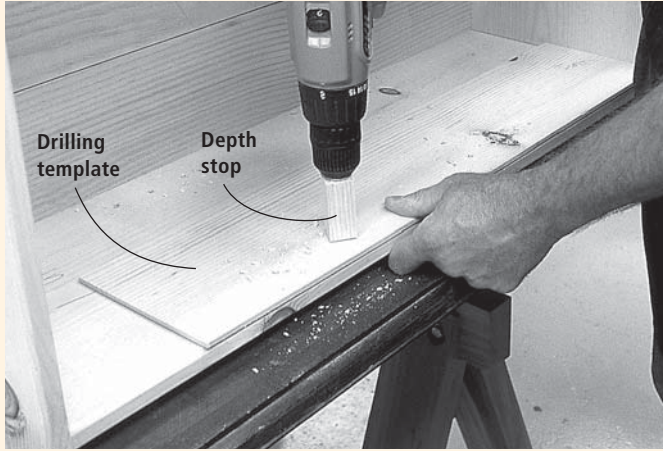

Two tips to drilling for shelf supports are evident in this photo. One is a simple drilling template that will always index off the bottom of the shelving unit. The other is a simple depth stop slipped over the drill bit to guarantee the proper depth for the shelf pin.

Shelving Supports

While most woodworkers are aware of the fact that they're adding shelves to their cabinetry, they may not plan very far ahead as to how those shelves will be supported in the carcass.

As you can see from the brief selection of shelf supports shown at the right, there are lots of things to consider. And there are lots more than those shown.

The critical things to consider when selecting a shelf support are stability, visibility and flexibility.

If you're loading your shelves with 150 pounds of books you would be best

served to consider metal rather than plastic supports. Another stability factor is whether the shelf will shift on the supports. The straight pins shown are attractive, but have very little bearing surface against the bottom of the shelf and will allow the shelf to slide forward easily. It only takes a 2" shift to drop the whole shelf off its back pins. Supports with a flat bearing surface offer better support, and a rubber pad will eliminate any slide.

Visibility is always important. If you build an attractive piece of furniture you don't want to junk it up with lots of support items. The "standards with clips" shown at right are mostly there as a bad example and in my opinion should be relegated to laundry-room storage. A number of the supports shown space the shelf away from the cabinet side, leaving a gap that's unsightly and sloppy looking. The "low profile" and "hidden shelf wire" supports offer very clean looks, and the fact that the supports are trapped in the shelf itself also offers great stability.

Versatility is a double-edged sword. While you want to plan ahead for usage changes and make it easy to move a shelf an inch or two in either direction, a row of shelf pin holes can be fairly unattractive. The diameter of the holes required for each of these supports vary, with the straight pin and hidden wire supports requiring very small holes.

Alternatively, the spoon pins are available with matching finish metal sleeves to dress up the holes, so even though they're visible, they blend in.

Standard with Clip

One of the most common, inexpensive, versatile and ugly supports available. Easily adjusts in 1/2" increments. The track should be grooved into the case side, requiring a router or table saw operation.



Reinforced Support

Inexpensive plastic support, slips into single or series of evenly spaced holes in the case side. Because of the back flange this support holds the shelf away from the cabinet side by as much as 1/8".



Right-angle Support

This support is almost invisible once the shelf is in place. The optional rubber pad helps keep the shelf from sliding. This support still holds the shelf away from the side of the case, leaving a gap.



Straight Pin

Offers low visibility (only seen under the shelf) and requires no gap between shelf and case side. Holes must be drilled to accurate diameter or the pin can slide out of hole and make the shelf unstable.



Spoon Pin (with sleeve)

A refined version of the pin above. Can be used with or without sleeve. No gap between the shelf and case side and the flat "spoon" holds the shelf better than the pin and also is less visible beneath the shelf.



Low-profile Pin

Economical (plastic) and invisible support requiring a single hole. A series of holes is also possible, but this would defeat the invisibility. Extra machining (stopped grooves in the shelf edge) are required.



Hidden Shelf Wire

A metal version of the pin above, it offers an invisible means of support with no gap between the shelf and case side. Again, a stopped groove in the shelf edge is required. The metal is stronger, but the single support requires an accurate fit in the groove.

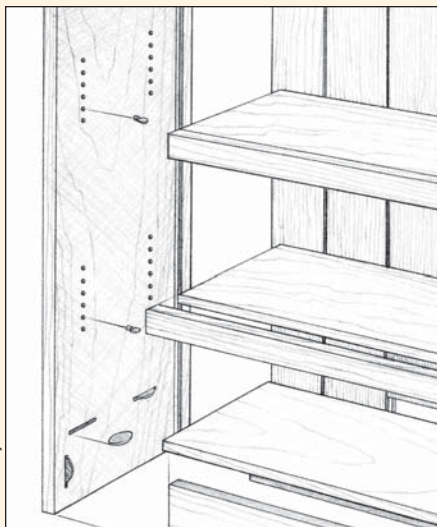
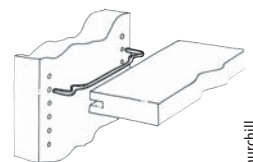
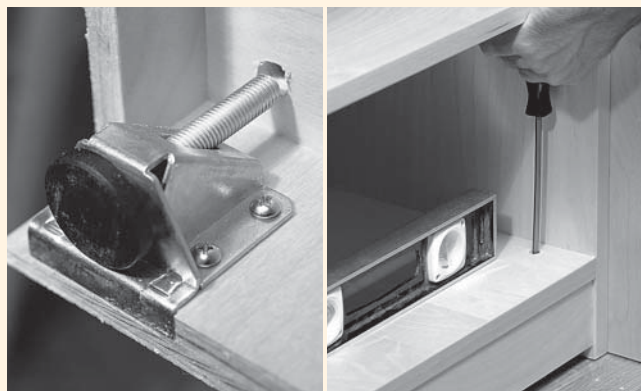

Illustration by Len Churchill

Planning for the future is an important part of drilling for shelves. While you may know what will be on the shelves today, next year you may require different spacing. By drilling a series of evenly spaced holes you will have room to grow in either direction.

Illustrations by Len Churchill



Leveling a cabinet is always a tricky process, but this clever piece of hardware makes it a snap. Built into the space behind the base is a leveling foot that can be accessed through the bottom shelf once the cabinet is in place. When level, a plug or cap is used to hide the access hole.

Specialty Hardware

The specialty hardware category will fill a book and already fills dozens of pages in most woodworking catalogs. Here are two that have significantly improved casework for our staff.

Casework pieces usually fit against at least one wall, and leveling the piece so that it aligns properly with the surroundings can be tricky. Shims, scribing and any number of other techniques are used daily, but the little piece of hardware shown above is well worth the extra expense. The leveler (actually four, if you're doing it right) is installed beneath the lower shelf and behind the kick plate of the cabinet. A small hole in the shelf allows you to adjust each leveler until the cabinet sits correctly.

While the photo shows this hardware installed in an assembled cabinet, you can also use this hardware on a base built separately from the cabinet. This method allows you to level the smaller (and more manageable) loose base, then simply slide the cabinet in on top of the base. No holes in the cabinet are necessary when using a loose base.

While many case pieces use drawers that have integral fronts, many use a false or added drawer front. False fronts allow you to leave space for drawer slides without having to delve into complicated joinery to mate the drawer sides to the front. False fronts also let you adjust the drawer boxes so they are level side to side and front to back in the cabinet, then adjust the drawer fronts to align perfectly with the cabinet.

This last aspect is significantly important when aligning inset drawer fronts where the spacing around the fronts should be perfect to offer the best appearance. For years woodworkers have used double-stick tape or even hot-melt glue to affix the false front in place on the drawer box, adding the permanent screws once all is aligned. The one problem is that tape and glue space the front away from the drawer box somewhat and don't allow room for easy adjustment.

The drawer front adjuster shown below solves the space problem while still offering plenty of room for adjusting the false fronts. **PW**

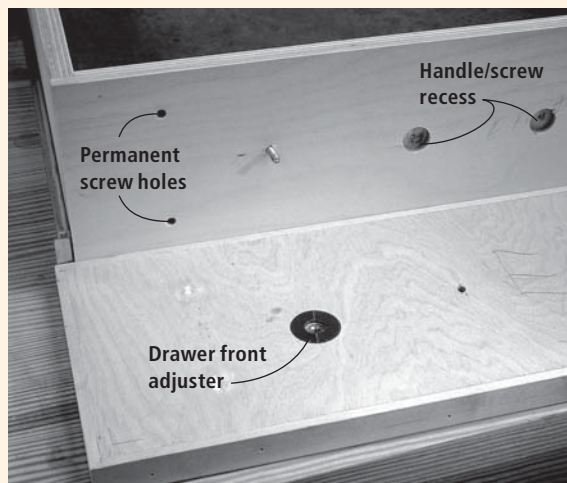

Added drawer fronts are very common and add significant convenience. But aligning the front once the drawer is in place is usually a slide-adjusting nightmare. The round device mounted in the front is a drawer front adjuster. The inner sleeve allows the drawer front to move 1/8" in all directions while in place on the drawer. Once things are aligned, the permanent screws can be added. Also shown is a recess in the drawer box so the handle will mount only to the drawer front, again easing adjustment.

Everything you need to know about case construction!

Building cases (from jewelry boxes to kitchens) is the basis of all woodworking. This series will give you the details you need to design, build and outfit your next project.

Chapter 6 Cabinet Hardware

From drawer slides to hinges, learn how to add the best to your project.



IN FUTURE ISSUES

Chapter 7 Special Applications

Whether it's an entertainment unit or a closet rehab, we give you what you need.



IN PAST ISSUES

Chapter 1 (ISSUE #150)

Beginning Principles

A look at the history, parts and stresses involved in case construction.



Chapter 2 (ISSUE #151)

Wood Selection and Preparation

How to choose the best wood for your project and make sure it's ready to use.



Chapter 3 (ISSUE #152)

Case Joinery

Learn the best way to put all the pieces together – from simple to sublime.



Chapter 4 (ISSUE #153)

Smart Assembly

Knowing what joint to use is only half the battle. Making the assembly easy and safe is the other half.



Chapter 5 (ISSUE #154)

Doors & Drawers

Doors and drawers make your casework efficient and add attractive storage.



Back issues can be ordered online at popularwoodworking.com or call 1-800-258-0929.

Pocket Mirrors

Pocket mirrors are a fun project to turn and are very popular for gifts and craft show items. The ladies find the highly figured wood very attractive and the hand-painted floral pins from Russia add another fascinating feature. Present the pocket mirror in an attractive bag and you have a complete gift for the most discriminating customer.

Take a turn at creating these decorative reflections of your craft.

by Dale Nish

A professional woodturner and retired industrial education professor, Dale is the author of three woodturning books, including the landmark "Creative Woodturning" (Brigham Young University Press).



1 Select a piece of highly figured wood, such as this piece of fiddleback western maple. Band saw it to a thickness of $\frac{3}{8}$ " to $\frac{7}{16}$ " thick, and wide enough to make a circle about $3\frac{1}{2}$ " diameter. Then use a compass to lay out a $3\frac{1}{2}$ " circle and use a band saw to cut it to shape.



2 Fasten a $\frac{3}{4}$ "- to 1"-thick waste block to a 3" faceplate and true it up on the lathe, then face off the waste block until you have a smooth, flat surface.

Cut off three strips of double-faced tape, each about 3" long. Remove the backing from one side of the tape, and place the sticky side down on the waste block. Cover the block evenly, then remove the backing from the top side of the double-faced tape. Place the round disc onto the waste block, being careful to center it on the waste block. Press the disc firmly against the waste block.

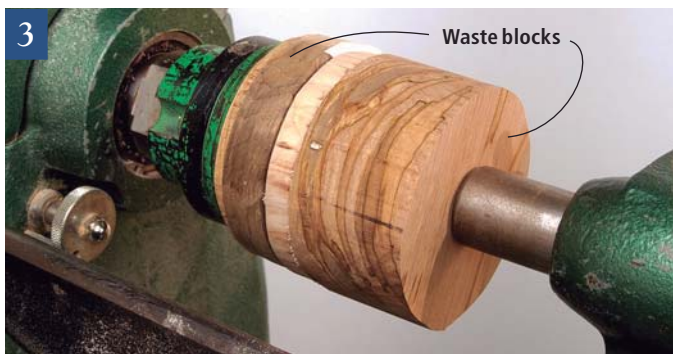

3 Install the waste block assembly on the lathe. Use another waste block to help press the mirror disc firmly against the tape. Use the lathe tailstock as a clamp, putting firm pressure on the mirror blank, causing good adhesion to hold the blank in place during turning and finishing. Keep the pressure on for a few minutes, then back the tailstock away and remove the extra waste block.



4 Set your lathe speed between 1,500 and 2,000 rpm. Use a $\frac{3}{8}$ " spindle gouge to make a shearing pull cut across the face of the blank. Check for a clean, flat surface.



5 Once the face is clean and flat, true up the edge of the mirror blank using a shearing cut, removing just enough wood to leave a smooth and clean surface.



6 Mark a true center on the blank, then measure back about $1\frac{1}{8}$ ". Turn the lathe on and mark a $2\frac{1}{4}$ "-diameter circle, which is the size of the mirror.

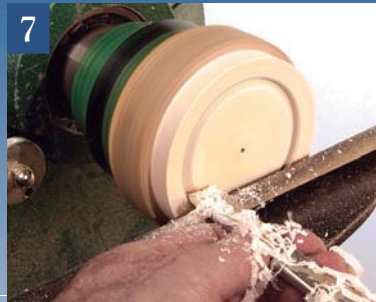

7 With the long point of a $\frac{1}{2}$ " skew chisel, cut a groove inside the circle line, about $\frac{1}{8}$ " deep. The first cut should be inside the finished opening to allow for precise fitting later.



8 Remove the rest of the wood inside the opening, making a recess close to finished diameter and about $\frac{1}{8}$ " deep. I am using a $\frac{1}{2}$ " square nose chisel, but a $\frac{3}{8}$ " gouge would work just fine. It is important to have the bottom of the recess flat and clean.



9 Make a loop of masking tape, sticky side out and press part of the loop onto the face of the mirror. Now, place the mirror into the opening and check for fit. If it is a little tight, make another fine cut with the point of the skew, then check again. The mirror should have a little wiggle room, about $\frac{1}{64}$ ", to allow for wood movement.



10 Cut a shallow cove around the mirror opening. Use a $\frac{3}{8}$ " gouge, taking a fine cut to get a smooth, clean surface that will need very little sanding. The cove should get down about half the depth of the recess. As the mirror is tapered, the cove acts as an accent around the mirror.



11 Shape the edge of the mirror blank using a $\frac{3}{8}$ " gouge; make fine, shearing cuts to make the edge round all the way to the back.



12 Sand the turned areas, but not the flat inside recess. I usually use #100, #150, #220, #320 and #400 grit. Try to keep the lines sharp and crisp.



13 I apply a high solids lacquer while the mirror blank is still on the waste block. This spray lacquer dries quickly; in two or three minutes, give it another coat. Let it set for five or 10 minutes, then cut the finish back with 0000 steel wool and wax. All application of finish is done off the lathe. All sanding and the application of steel wool and wax is done on the lathe, with the work spinning.



14 Use a wood chisel and gently pry the mirror blank off the waste block. Use a gentle but steady pressure and the tape will gradually separate from the waste block. Now, remove any tape left on either piece.



15 Remove part of the waste block, tapering the block down about a third of the way, but leaving enough to make a $2\frac{1}{4}$ " stub tenon which will fit inside the mirror recess of the blank.



16 This needs to be a snug fit, but should not be so tight that the blank needs to be forced on.



Put two strips of double-faced tape on the tenon using the method shown in picture 2. The tape should not extend beyond the tenon or it will interfere with the fit.



Face off the surface of the stock, leaving it smooth and free from irregularities.



The insert in the photo is a hand-painted Russian pin. The fastener has been removed and the back of the pin sanded flat. Due to slight size variation, each pin must be custom fit. The pin has tape on it so it can be held for sizing the recess and checking the fit.

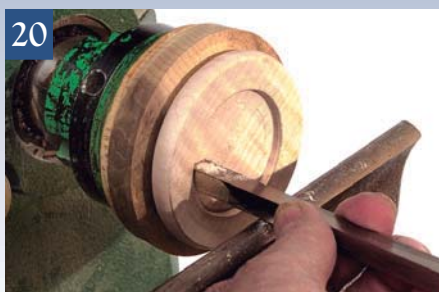

Cut the recess with the long point of a skew chisel, then use a 1/2" square chisel to complete the recess in the manner shown previously in pictures 7 and 8. The bottom of the recess should be flat but doesn't require sanding.



Sand through the grit sequence of #100, #150, #220, #320 and #400.



Apply two coats of lacquer a few minutes apart. Set aside to dry for five to 10 minutes.



With the lathe running, use 0000 steel wool and wax to produce a glass smooth finish with a low-gloss sheen. Final polishing is completed using a soft flannel cloth. This method can be used to produce a luster from low to high gloss.



The mirror can be glued in place with a few spots of silicone adhesive.



The same method is used to glue the floral Russian pin in place. Set aside for several hours, preferably overnight to allow the adhesive to set. **PW**

SUPPLIES

Craft Supplies USA
800-551-8876 or
woodturnerscatalog.com

Pocket Mirror Kit includes:

- 2 1/4" beveled mirror
- Russian lacquer insert
- 15" double-faced tape
- figured maple blank
- felt pocket mirror bag

#930-0002, \$15.99 postage paid



Pleasant Hill
**SHAKER
CUPBOARD**

Common wood from a common source
creates an uncommon beauty.

I began my study of the Shaker furniture at Pleasant Hill, Ky., with a quick survey of the contents of the enormous Centre Family Dwelling, sticking my head in the door of each room, making a mental note of everything that caught my eye: a table here, a chair there, a little blanket chest, a tripled clothes hanger.

Each item on my mental list had something about it that set it apart from other objects in the Dwelling. In some cases, it was a splash of color, in others a bit of intriguing joinery, in others a form that deviated from Shaker norms. In this manner, I chugged along for maybe half an hour: Looking, storing and getting excited about the prospect of looking more closely later on.

Then, in a room on the second floor, I saw this cupboard hanging from a peg rail above a wash stand. I stuck my head in, caught my breath, released it and then slowly entered the room. The cupboard was familiar (Christian Becksvoort's book "The Shaker Legacy" [Taunton]), but I had forgotten about it. I know I wasn't expecting to see it there.

I stepped over the low railing erected to keep the public at a distance. (I had permission from the curator.) I stuck my nose close to the piece to study the pegs that penetrated the joinery of the frame-and-panel door, then backed off. This was something special, something profoundly Shaker, something that – unlike many pieces in the Pleasant Hill collection – could never be attributed to country origins.

The editors at *Popular Woodworking* had sent me and the mag-

azine's photographer, Al Parrish, to the Shaker Village to write and illustrate a couple of articles about Western Shaker construction methods and design.

Nobody told me to do any measured drawings, but when I took the job, I was pretty sure I'd end up drawing at least a few pieces, and as soon as I saw this cupboard, "pretty sure" changed to dead certain.

Material from a Home Center

I usually buy lumber from hardwood dealers – businesses that typically require a 100 board feet (bf) minimum order. So I can't buy, for instance, 75 bf of curly maple or 50 bf of cherry.

In most cases, I don't mind these minimums. I always need cherry, walnut and curly maple. But sometimes, I don't really want 100 bf of a particular species, and anyone buying small lots of hardwood at stores catering to woodworking hobbyists will find he needs the support of a full-time cardiologist when they check out at the cash register.

Recently, I've been experimenting with another source for poplar: my local home-center store. All the big home-center stores charge more per board foot than hardwood dealers. But there are some good reasons to consider these type of suppliers for poplar (and pine).

For one thing, the material has been surfaced, and let's face it: One of the more odious chores is



Step photos by the author

Although it's possible to drive nails into "green" hardwood without pre-drilling, thoroughly dry hardwood requires pre-drilled holes – that is if you want to avoid split stock. The through hole should be nearly the same diameter as the shank of the nail. The hole that penetrates the second piece of stock should be a bit smaller in order to give the material a good grip on the nail.



Tap the shelf into its dados using a protective block of scrap.

flattening and thickening material. But here's a more important reason: I can buy only perfect boards. If there's a knot, a split, a bit of wane, I don't buy it. If it's not perfectly flat – and I mean billiard-table flat – I put it back.

Try that with a hardwood dealer. He might let you set aside a few boards with egregious defects, but if you reject eight boards out of 10, he might decide he doesn't want your business after all.

In fact, I have developed the habit of buying all my secondary wood this way. Every time I go to the store, I sort through all the poplar and clear white pine, and I buy every perfect board. This little cupboard is built of poplar I'd culled from the home-center's stock over the previous month.

Assembling the Case

I chose to use 8d coated nails to assemble the cupboard because the nail heads visible on the original are about the size of 8d nail heads, and I knew 8d nails, which are 2½" long, would result in a solid construction. Eight penny

by Kerry Pierce

Kerry is the author of "Authentic Shaker Furniture" (Popular Woodworking), "Making Shaker Woodenware" (Sterling) and numerous other books. He teaches Shaker chairmaking at the Marc Adams School of Woodworking.



Use a plane to level the edges of the cupboard's case before you attach the face frame.



Although the bead on the Shaker original was likely made with a scratch stock (because there is evidence of this tool everywhere at Pleasant Hill), I chose an 1/8" side-bead plane.

nails are big for this application, and I think you could have good results with a 7d nail as well, but I wouldn't recommend anything smaller than that.

Initially, the whole nail thing made me uncomfortable. I've spent too many years cutting wood-to-wood joinery to embrace this (sacrilegious?) method of work. But early in the construction process, I had to remove a piece I'd nailed in the wrong location, and let's just say I'm convinced this little cupboard will never come apart.

These nails require the drilling of two holes. The first is a through hole in the board you're nailing through. This hole should be just large enough for the shank of an 8d penny nail to pass without being driven by your hammer.

The second hole should be the full length of your 8d nail and just a bit smaller than the shank of the nail. It has to be small enough so that you have to drive the nail in with your hammer but not so small that seating the nail results in split material. As always, experiment on scrap before you work on the good stuff.

If you look at the photo on the previous page, you'll see me drilling the smaller hole in a partially assembled joint. The drill for the larger, through hole, sits on the bench behind me.

After nailing the carcass together, fit the shelf and tap it into its dados.

The original cupboard has only one shelf, although there are dados for two equally spaced shelves. I thought that an interior divided into only two compartments, instead of three, made more sense on this modest-sized cupboard, so I eliminated the second shelf the original cupboard

had at birth. This gave me a fairly small compartment above and a larger compartment below.

After the shelf has been nailed into place, level the cabinet front and back with a plane

The cupboard has 1/8" beads along each of the front corners and around the door frame. The beads on the corners are cut on both the front and side of the vertical parts of the cupboard front.

This produces a bead that's visible from either perspective.

If you haven't used a moulding plane, an 1/8" side-bead plane (shows at left) is a great place to start. You can find these relatively common planes at flea markets, antique malls and, of course, on eBay. But you must be sure to purchase a plane with a reasonably straight sole. Some have bowed beyond repair in the century and a half since their creation. "Reasonably" straight, however, doesn't mean "perfectly" straight. This little 1/8" side-bead plane I'm using here has a bit of a bow but it still works fine.

Unlike most moulding planes, which are designed to be held at an angle (the spring angle), side-bead planes are designed to be held upright, their sides perpendicular to the surfaces being worked. Set the iron so that it's barely visible when you sight along the sole of the plane, tap the wedge firm, then crowd the plane's fence against

PLEASANT HILL SHAKER CUPBOARD

NO.	ITEM	DIMENSIONS (INCHES)			MATERIAL	COMMENTS
		T	W	L		
☐ 1	Top	3/8	7 1/2	31 7/8	Poplar	
☐ 1	Bottom	13/16	7 1/2	32	Poplar	Stock can be slightly oversize
☐ 2	Sides	13/16	5 7/8	17 13/16	Poplar	
☐ 1	Face frame top rail	13/16	2 7/16	20	Poplar	
☐ 1	Face frame rail	13/16	1 7/8	20	Poplar	
☐ 2	Face frame stiles	13/16	5 7/16	17 13/16	Poplar	
☐ 2	Sub top/bottom	7/8	5 7/8	29 1/4	Poplar	
☐ 2	Sides	13/16	5 7/8	17 13/16	Poplar	
☐ 1	Shelf	3/4	5 7/8	30	Poplar	In 3/4" x 3/8" d. dados
☐ 2	Door rails	13/16	2 7/8	16 1/8	Poplar	2" tenons on each end
☐ 2	Door stiles	13/16	3 15/16	13 1/2	Poplar	
☐ 1	Door panel	5/16	8 5/8	13	Poplar	1/16" gap all around
☐ 2	Hangers	5/16	2 7/8	27	Poplar	
☐	Backboards	5/16	30 7/8	17 13/16	Poplar	Random widths to fill 30 7/8"
☐ 1	Knob *	1	1	1 11/16	Walnut	
☐ 1	Catch	1/4	7/16	3/4	Walnut	

* I made the knob 1/8" longer than the original knob. This was a mistake, one I didn't notice until I prepared the materials list. The extra length is in the long cove. The length I give in the materials list is the length of the Shaker original to match the drawing.

** The hinges on my reproduction also are historically inaccurate. The hinges on the original are 1 3/4" long (as they appear on my drawing). Here, too, I made a mistake. I marked and mortised for a pair of 2"-long hinges, thinking—for some reason—I was working with 1 3/4"-long hinges.

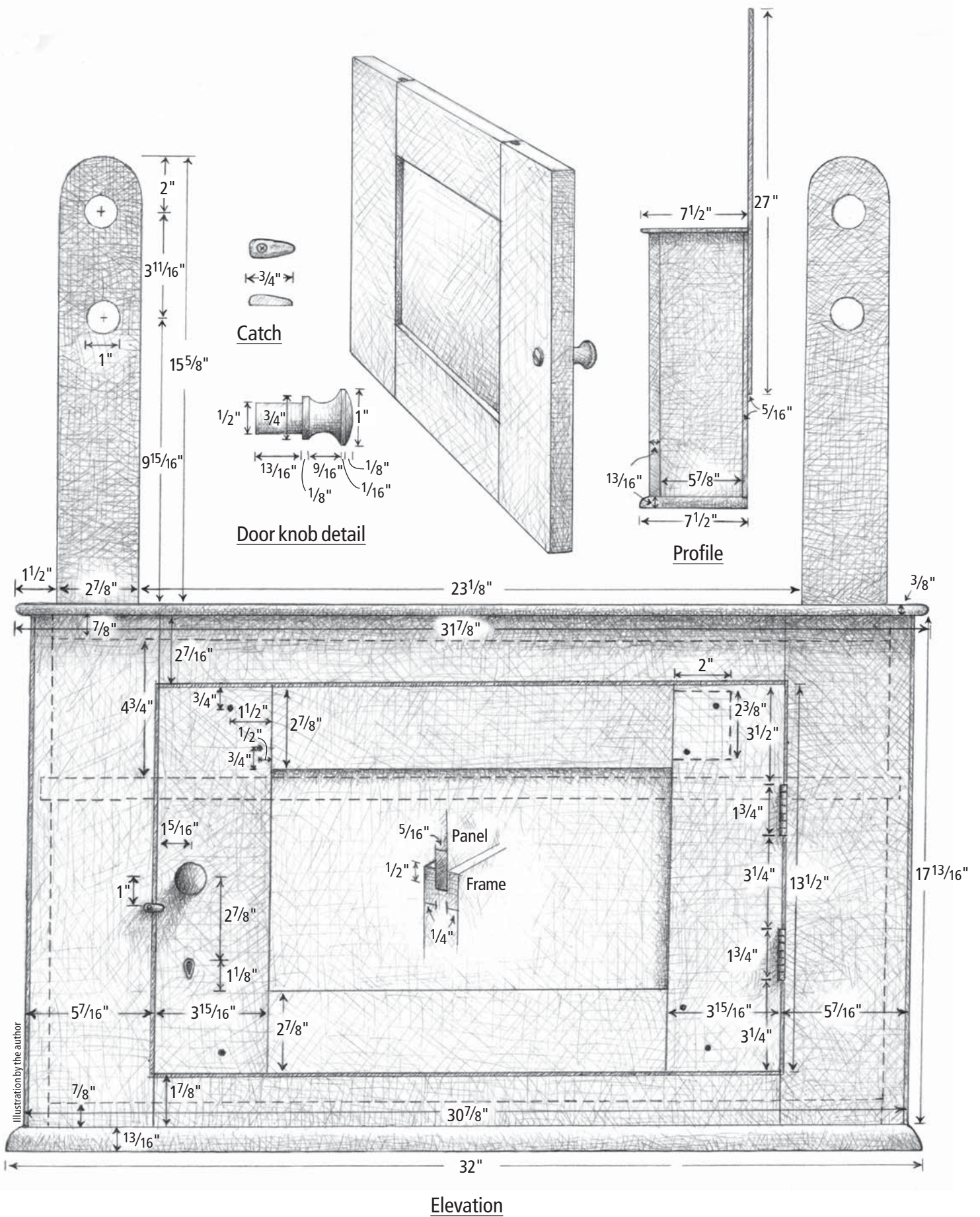



The junction of the horizontal and vertical beads must be completed with a little paring chisel work.



Carefully drive the nails that attach the face frame. (If you miss and ding up your stock, don't despair. Just spoon a bit of water onto the ding. As the fibers swell to accept the water, the surface of the wood will return to its original configuration.)

the edge of the work and push the plane forward. If you have the right amount of iron exposed, a tiny shaving will squirt out the side of the plane. (Test the plane's setting on scrap before working on the cupboard stock. A rank iron – one set too deep – can tear out the bead.) After a half dozen passes, you will have defined a neat little bead and quirk.

If you prefer routers, there are $\frac{1}{8}$ " bead cutters available that will simulate the work of this plane.

Cutting the bead around the door on the face frame stiles of the cupboard front requires a little trickery because you simply can't do it with a properly set up side-bead plane. This is because the bead doesn't run all the way to the ends of the boards on the face-frame stiles (although the bead does run from end to end on the face-frame rails so these beads can be cut in the way I'm demonstrating here.)

Caveat: The Shaker maker might have done this with a scratch stock. A scratch stock is nothing more than two pieces of scrap wood between which is sandwiched a small bit of metal filed to the necessary profile. The wood part of the scratch stock provides a way to hold the metal at the necessary angle without damaging the craftsman's fingers (it also stabilizes the metal), while the metal cuts the bead with a scraping action. It's simple but effective



Bench planes can be made to do a fair amount of edge shaping. Here, I'm using a bench plane to create the radius between a line drawn on the edge and a line drawn on the top of the cupboard bottom.



These narrow, deep mortises can be tricky to chop with hand tools.

when properly sharpened.

You can, however, cut the stopped bead on the face-frame stiles of the cabinet front with a side-bead plane if you cheat a little. Tap the iron down so that it hangs an extra $\frac{1}{8}$ " or so from the sole of the plane. That will allow the iron to engage the work when the sole of the plane is not riding down on the bead you're cutting. You are in effect, using the side-bead plane as a beading tool. This too is something you should experiment with on scrap before trying it out on the good stuff.

Nail the components of the face frame into place.

After the frame has been attached, you'll then finish the bead around the door with a paring chisel as shown above, followed by sandpaper.

The cupboard top and bottom both have radiused edges. The top has a 180° radius, the bottom only a 90° radius. These radii can be formed with moulding planes (or roundover bits in a router), but I've always made this shape with a bench plane as I'm doing above. You'll be amazed at how quickly you can do this work – much more quickly than you could set up a router to perform the same operation, and of course working with a plane means no dust and no noise. The shop remains quiet enough so you can plan the next few steps in the construction process.

If you choose my method, you'll first need some pencil lines to plane between. One of these lines should identify the midpoint of the board's edge. The other line should be placed on an adjacent

surface a distance from the edge that is equal to half the thickness of the board.

To create the radius, simply remove shavings in the area between these lines until, working by eye, you've established the rounded edge.

You should create the radii on the ends of the board before tackling the long-grain radius to avoid tear-out at the corners.

Nail the shiplapped backboards onto the back of the carcass. Then nail the top and bottom in place.

Making the Door

The cabinet took me maybe three hours to assemble. The door took a day and a half to build and fit. In part, this is because the door is the only element with any tra-



Before you glue up the door, lay out the parts and make certain that they will all come together during glue-up.



Riven pegs are not only historically accurate, they are also stronger than sawn pegs because they eliminate the possibility of grain run-out.

ditional joinery, but primarily, it was because doors require a lot of careful fitting.

The original door has 1/4"-thick x 2"-wide x 4"-long through tenons on the rails. And so did the first door I made for this particular reproduction.

But the mortises must have been a little out of whack because when I assembled the door, it had an unacceptable amount of twist, a result probably of an incorrectly cut mortise. This is something that's easy to do when chopping long and very thin mortises by hand. So I made a second door, this time with mortises only 2" deep. These were much easier to cut accurately, and a tightly fit 2"-long tenon has more than enough glue surface for this door, particularly when the glue joints are reinforced with 1/4" walnut pegs.

The photo at the top of the page shows the door components before the door was glued up. Notice the 1/4"-wide, 1/2"-deep through grooves milled into all of the inside edges of the door's rails

and stiles. The flat center panel floats in these grooves.

The door is opened with a turned walnut knob. I turned two knobs from the spindle shown because I had decided to make a pair of these hanging cupboards.

The final touches on the door are the 1/4"-diameter pegs that reinforce each tenon. Cut off a length of walnut (or some other durable, easily split hardwood) that is a bit longer than the thickness of the door components. Then, with a wide chisel, tapped with a hammer, split off squares about 5/16" on a side. Pare these squares into approximate rounds, holding the individual pegs as shown above.

The splits in the center of the photo are the splits from which the pegs are shaved. The pegs on the left have been shaved close to their final shapes.

Cut and shape the hangers as shown in the illustration. Nail them to the back—place the nails so you catch a shelf and the sub top of the carcass.



Use a skew to shape the top of the knob and a fingernail gouge to cut the cove. The tenon can be cut with a paring chisel laid flat on the rest with the bevel down.



The original cupboard had been stained. I chose to use a primer and paint combination in order to best mimic the look of the aged original finish.

Finishing

The original cupboard was stained red, but I opted for paint in order to conceal the nail heads. I began with a coat of latex primer, which I sanded, then followed that with two coats of a "designer" red that approximated the color of the original piece.

Of course, the problem with paint is the dimensional change it causes. Each layer of paint adds measurably to the width and thickness of the part to which it's applied. A door stile that was 4" wide after sanding, might be 4 1/8" wide after applying three coats of paint. So even though I had fit the door with a comfortable 1/16" gap all around, after painting, I had to remove the door and plane off additional width from all the rails and all the stiles and then repaint those planed edges in order to get the door to open and close properly.

My wife asked me how the Shakers might have used the original cupboard. I had to tell her I didn't know.

Because it was poplar—rather than, say, cherry or curly maple—it probably was a utility cabinet of some kind, maybe something that hung in a washroom, something that might once have held soaps or cleaning brushes, but because it was so portable—just remove it from the pegs in one room and hang it from the pegs in another—it might have had several incarnations in its original life, as the Shakers moved it from room to room to suit the needs of a community dwindling steadily in size over the years.

My wife decided to hang hers in the kitchen. She's going to fill it with spices, and then use the top surface to display her collection of antique tin cans with brightly lithographed color labels. **PW**

Side Sharpening

You can sharpen freehand with quality results if you remember that wider is better.



by Harrelson Stanley

Harrelson is a teacher and importer of fine Japanese woodworking tools and accessories. He is also the host of a number of videos, including one discussing his side-sharpening technique in detail. To learn more about the video, visit japanesetools.com.

I like to equate sharpening to a golf swing. Through practice, you memorize the motion that will improve your game. You can always get better, and there's always something new to learn.

For me, sharpening is just as much fun as planing – or hitting a bucket of balls. I don't find it to be drudgery at all, because I have a system that responds to my needs as a woodworker. An important part of that system is something I call "side sharpening." Trying to balance the blade on its narrow bevel while sharpening is asking for trouble. It's much easier to sharpen using the width of the blade to support the bevel.

Along with side sharpening, keeping your stones flat as you sharpen, properly removing the burr, and another step that I call "jointing" the edge, all combine to make a simple and efficient system for sharpening plane blades.

Flat Backs Make Sharp Edges

The first time you sharpen a blade it's important to flatten the back of the blade correctly. This is a one-time step. If you get it right the first time, you won't have to do it again for a very long time.

But before you put steel to stone, it's important to make sure each grit stone is flat. I use a diamond lapping stone for this step. Just a dozen or so passes with the diamond stone on each stone prior to use ensures that you'll be working with a flat surface.

To flatten the back, start with the #1,000-grit stone. Start with the edge of the back (I feel it's only necessary to flatten the first $\frac{5}{8}$ " of the blade), rubbing back and forth along the edge of the stone.

Keep your left elbow down low, perpendicular to the stone so that the rubbing motion is a smooth back-and-forth motion rather than swinging up and down. This keeps a constant, even pressure on the blade. If you're left handed, feel free to switch hands; it's an ambidextrous method.

This process is repeated through the multiple grits until you've achieved a clean, flat and polished surface. For the best results, I recommend working through all seven grits (#1,000 to #16,000).

Before moving to the bevel, it's time to "joint" the edge. Simply set the blade perpendicular to the #16,000 stone, with just the edge touching the stone. While applying moderate pressure on the edge, run the blade lengthwise along the stone a few times. This jointing step removes any fatigued or ridged steel from the blade's edge and leaves a clean starting point for sharpening the bevel.



While a necessary step when first preparing a plane blade, flattening the back face only has to happen the first time and rarely thereafter. Start with the #1,000-grit stone, flattening the first $\frac{5}{8}$ " or so of the blade.

Photos by the author

GRIT PROGRESSION

As you work through the multiple grit stones you remove the scratches left from the prior stone. The photos below show the scratch progression as the back is flattened and eventually polished.



#1,000 GRIT



#2,000 GRIT



#4,000 GRIT



#8,000 GRIT



#16,000 GRIT

(Blades shown at 200x magnification.)



An important part of the side-sharpening process is to grip the blade correctly. The blade is grasped loosely in the right hand, held by just the fingertips.



The right forefinger is held in position at the right front corner of the blade to steady the blade and provide balance.



The left hand provides pressure on the bevel. The hand is spread across the iron's width, parallel to the blade edge. The left arm is held rigid from finger tip to elbow.



Body position is important. Standing with my head positioned directly over the blade puts my line of sight directly in line with the blade tip and where I'm sharpening. This "line-of-sight" position is the same whether flattening the back or sharpening the bevel.



As you prepare to sharpen the bevel, the right hand is again loosely holding the blade, providing light support with the bevel flat against the stone. Seat the bevel on the stone. Your right hand is only supporting and balancing the iron; the index finger applies light pressure to hold the bevel flat on the stone.

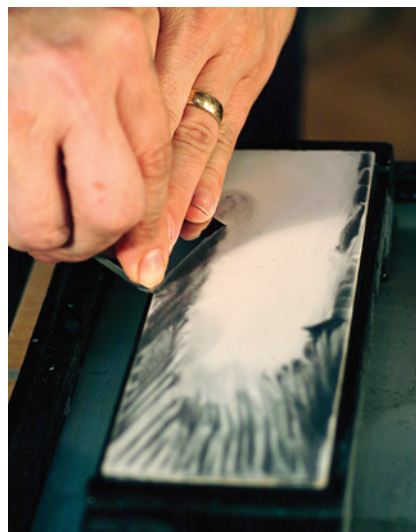

While ceramic stones cut quickly, they also wear slightly faster. Because of this, it's important to work to keep the stone's surface as flat as possible. By working around the perimeter of the stone and actually pushing off the stone, you'll use more of the stone, and not dish the center of it.

Here is the circular pattern that I recommend. I tend to work in a clockwise pattern, but if counter-clockwise feels more comfortable, that will work as well.

This is the point where the term "side sharpening" comes in. Rather than sharpen the bevel by pushing the blade in the direction you would when making a cut with the blade (and thus contacting the stone with only a small amount of metal), side-to-side sharpening allows you to use the more

substantial width of the blade to more fully support the bevel as you sharpen.

Seat the bevel flat on the stone and then start making short side pushes along the perimeter of the blade to come off the edge of the stone. By working only on the

perimeter, you avoid dishing the stone in the center, which can cause the blade to be rounded over on the bevel side. Keeping the stones flat makes the entire sharpening process easier.

After working through the first (and every) grit, you want to check for the burr that is formed as the

steel is rolled over the edge. This is fatigued metal and needs to be removed. I use my #16,000-grit stone and make a few passes on the flat back of the blade along the length of the stone. That's enough to shear off the burr.

One other step that I add between grits is a what I call a

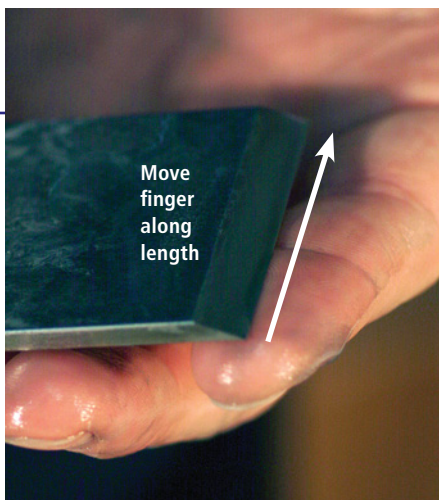

After sharpening the bevel with each grit stone, you will develop a wire-edge burr on the back side of the blade. I check the burr by running the blade over my fingers (carefully) along the length of the edge, never across the edge. This burr is fragile and if you run your fingers across the burr you stand a good chance of breaking the burr off leaving a very “toothy” edge that is more difficult to sharpen effectively. It’s best to shear the burr off, leaving a clean, even edge.

“jointing” pass. Even with the burr removed, there are microscopic teeth left on the edge of the blade. By making two light passes over my #16,000-grit stone with the blade held perpendicular, the teeth are effectively removed, much like a jointer removes the rough parts of a board.

As you move to the polishing stone to remove the burr, remember to first wipe the blade to remove the coarser grit slurry that remains on the blade from coming in contact with your polishing stone. Otherwise you’ll scratch the polishing stone and undo much of the polishing work you’ve accomplished (not to mention potentially damage the polishing stone).

Now I’m ready to move to the next grit and repeat the procedure. As you finish with the last grit, make one final short and light jointing pass on the edge of the blade, barely kissing the stone, to remove the last bit of tooth.

Once you’ve flattened your blade (once), and become comfortable with the side sharpening process, it should take you no more than three to five minutes to put a new sharp edge on your plane blade. So little time – yet you’ll get your plane cutting thin wispy shavings every time! **PW**

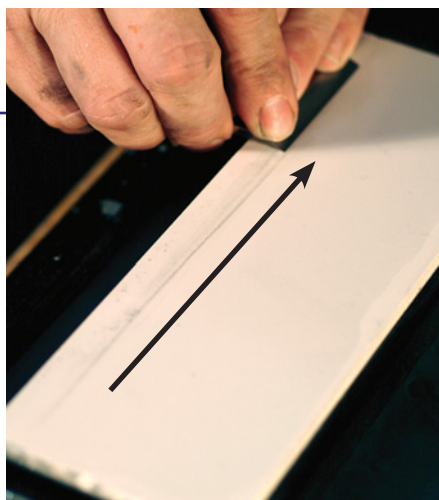

To remove the burr, run the back of the blade flat along the polishing stone (#16,000 grit) lengthwise a few times. By running the blade lengthwise, the burr is sheared from the blade, rather than broken free.



Even after removing the burr after sharpening with your finest grit stone, you can feel a slight “tooth” to the edge. A step I’ve added to address that is one I call “jointing the blade,” which removes that tooth by running the blade on edge, lightly along the length of the stone. You’ll feel the difference instantly.

NEW SHAPTON STONES ARE MORE AFFORDABLE

The only complaint you ever hear about Shapton stones is that they are pricey. And it’s true that they are more expensive than the Norton waterstones, though the Shaptons also wear more slowly in my experience.

Now there is a more affordable line of Shapton stones that are very close in price to the Nortons. These new Shaptons are thinner (5mm compared to 15mm) and are fused to glass for rigidity. According to our price comparisons at press time, the new Shaptons will be just a few dollars more than the Nortons, and available in a wider variety of grits (#220, #1,000, #2,000, #4,000, #6,000, #8,000, #16,000 and #30,000). I’ve been using the new stones for several months and am quite impressed. They wear very slowly and cut quickly – just like the thicker Shapton stones. Most home woodworkers will be hard pressed to wear out one of these 5mm stones in their lifetime. I think these new

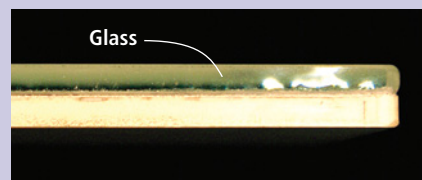

The glass backing strengthens the thin layer of sharpening medium.

Shaptons really narrow the gap between the two brands – though who knows how prices will fluctuate as market forces kick in. In any case, take a hard look at the new Shaptons. It’s high quality stuff and now at a more reasonable price.

The three stones I used the most were the #1,000 grit (\$42.95), the #4,000 (\$55.95) and the #8,000 (\$79.95). For more information, visit shaptonstones.com or call 877-692-3624.

— Christopher Schwarz

In the more affordable line of Shapton stones, stones are available in eight different grits. One nice perk of the new stones is the grit of each stone is clearly visible through the glass on the back.



Entertaining Designs



Illustrations by John Hutchinson

New TVs change the rules for designing cabinets.

by Robert W. Lang

Bob's latest book is "The Complete Kitchen Cabinet-maker" (Cambium). Contact him at 513-531-2690 ext.1327 or robert.lang@fwpubs.com.

A few years ago, I called a contractor I was working for to confirm the size of his customer's television set. It would be going in some expensive custom cabinetry, and like most entertainment centers, nearly every design decision would be based on the size of the TV. His reply? "Too wide by too tall by too deep. Just like always." While he was joking, it was humor based on bitter experience. One of the worst experiences a woodworker can have is investing a lot of time in a project only to discover at the end that the TV won't fit, the doors won't close or you get a crick in your neck when you sit down to watch.

This article is about developing workable designs, and not about construction. We turned our illustrator loose to build a “virtual” cabinet and take you through the process of developing a design to fit your room and your needs.

The techniques for building entertainment cabinets are the same as for building any other type of casework. A box is a box and a drawer is a drawer. Our Woodworking Essentials series on casework construction (issues #150 through #155) will help you make the cabinets; this article will help you decide what to make.

With entertainment centers, there are some important considerations due to the size and shape of the components and the media. Because every room’s design and every combination of audio-visual equipment will be different, you’ll need to utilize your design and problem-solving skills along with your cabinetmaking abilities.

Engineer First, Design Later

Whether you are building wall-to-wall built-ins or a freestanding shrine to your new widescreen, you need to select the size and type of TV first, and make sure that it will be in the right position for comfortable viewing. This should be the starting point for developing your design.

Great leaps in electronics have been made in the last few years, making larger screens much more affordable. The other good news is that today’s TVs are lighter in weight, and require less depth than those made just a few years ago. Although it may seem that it’s a problem like being too rich or too thin, you can get a screen that is too big for your room.

Before you commit to purchasing, get the dimensions of any TV you’re considering, and make a mock-up out of cardboard or foam

insulation board. Put this in the location you’re planning, take a seat on the sofa, and spend some time staring at it (beer and pretzels are optional). Sit in all possible locations in the room, and consider viewing angles both from side to side, and up and down.

It may look good on paper to place the screen above the fireplace, but in many rooms that will force you into an uncomfortable position for viewing. When you have settled on the size and location of the screen, as shown at right, you can begin to develop your design around it. In the drawing below, we take it one step further and make a full size mock-up.

Before you design how the cabinet will look, engineer it to be sure there is room for everything, and that it will be functional. Plan the dimensions of the cabinet around the TV screen, your other electronic components and the media you need to store. Use those dimensions to build a drawing of a simple box. Once this is established, you can then work out the stylistic elements of your design.

Even though TVs are lighter than they used to be, their overall width requires firm support below. $\frac{3}{4}$ " plywood will likely sag if it has to span more than 30", especially if it carries a load in the center. Solid-wood rails front and back, and even in between, will likely be needed. A vertical support of plywood may be used instead of rails to support the television.

In our design, we opted for cabinets to hold components and discs below the screen. This let us store CDs and DVDs out of sight in drawers, and the cabinet boxes provide a solid base for the screen.

The first step in creating a good design is to locate the TV screen in the room. Place a full-size mock-up on the wall. Then make sure it is the right size and will be in a comfortable field of vision from seating areas.

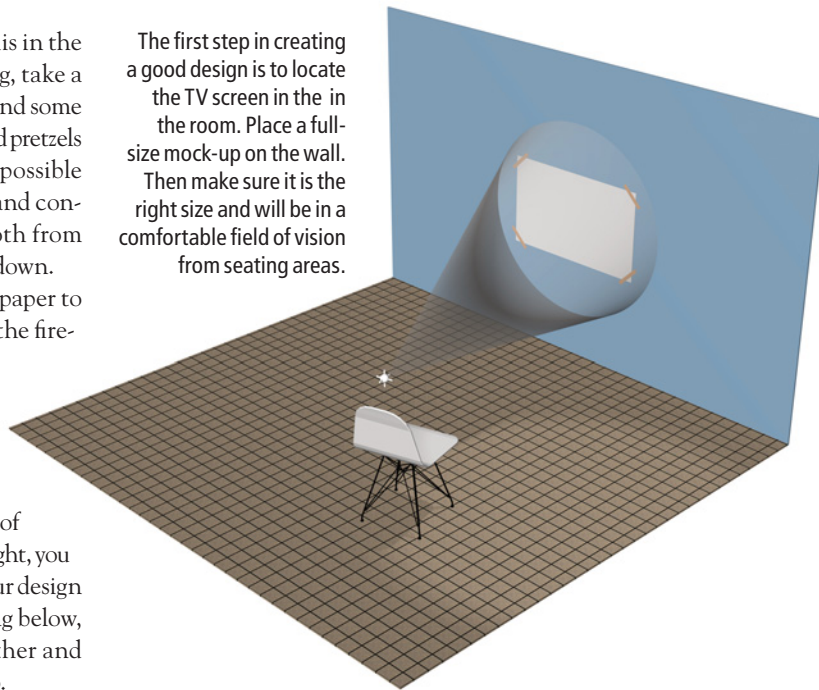

Changes for the Better

Older TVs were much deeper than today’s, and it was common to see deeper cabinets to accommodate this. In entertainment centers going from wall to wall, the cabinet containing the TV

would often project out in front of the other cabinets.

This projection is hard to make gracefully, so from that standpoint less depth is a good thing. The negative aspect of making a shallower cabinet is that there is

When you have the screen where you want it, you can begin to design the casework around it. Making a full-scale mock-up from cardboard boxes gives you a realistic view. If you’re not sure about the mock-up, leave it in place for a few days.

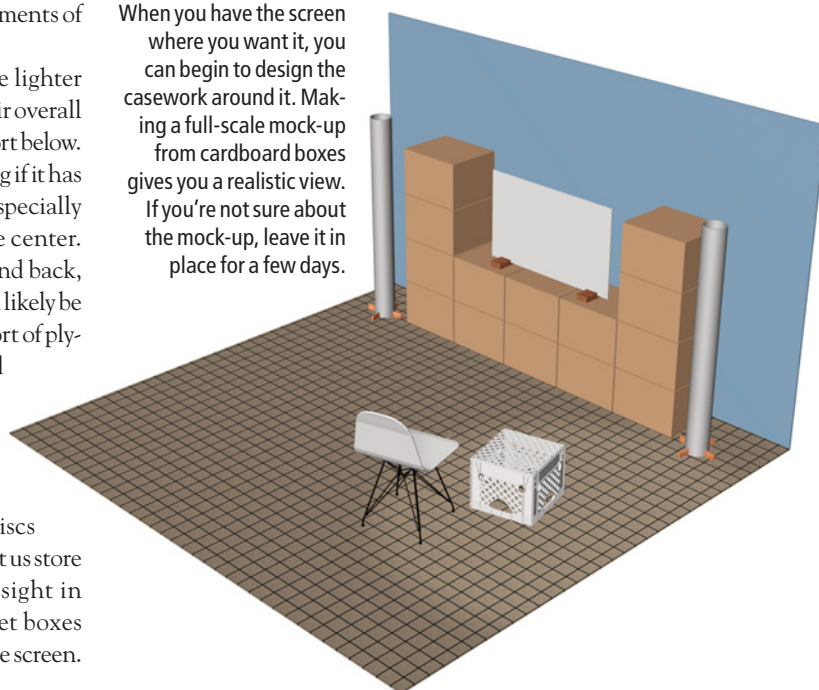

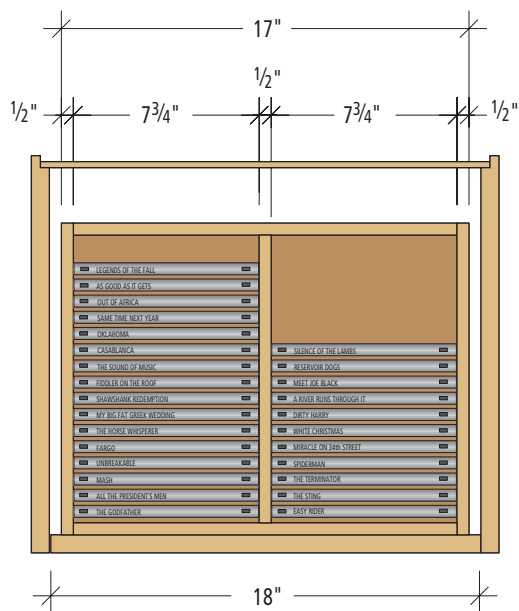

Plan: DVD storage drawer

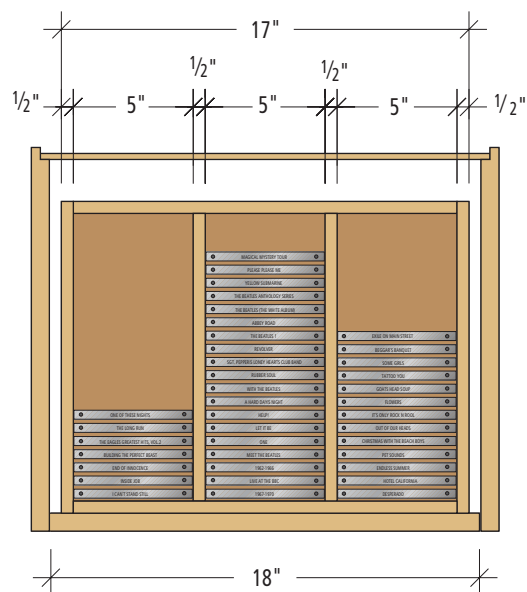

Plan: CD storage drawer

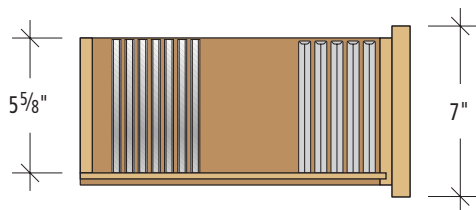

Profile: CD/DVD storage

We picked a height and width for our drawers that works well for storing CDs and DVDs, and sized the cabinets based on those dimensions. Three cabinet boxes placed side by side work as a support for our widescreen TV.

no longer enough room to allow pocket doors to retract.

On the other hand, this isn't all negative. While many past designs featured retractable doors so the TV could be hidden when not in use, in reality, almost no one ever used this feature.

To hide the TV in a shallower cabinet, bi-fold doors or doors that slide sideways past the set are workable options. The drawback to using either of these is that the doors will always be visible, and likely in the way of some other part of the cabinets. Tambour doors are another option, but the size needed would present quite a challenge. (If you think you need doors to hide the screen when you're not watching it, give that some serious thought before committing to the effort.)

We opted for tall cases on either side of the screen, omitting doors and leaving space for an even larger screen in the future.

Many LCD and plasma TVs are only a few inches deep, but the front of the screen should still be flush with the front of the case-work. The empty space behind will provide ventilation and room for cords and connectors.

With the size and location of the TV determined, consider next any other electronic components, speakers and media storage that will be included. Again, it makes sense to have the components in hand so that you can base the design around them.

The heat generated by modern electronics can be considerable, so you want to be sure you provide adequate ventilation. Leave the back off the cabinet, provide some room for air to circulate and consider installing a fan to keep things cool. Once you have the footprint established, you can make a cutout in the shelves that hold your components to allow air to circulate from below.

Shrinking Electronics

Electronic components, such as DVD and CD players, are typically smaller than they were just a few years ago. Most are less than 4" high, and many are less than 10" deep. A common width is 17" but don't base your design on the assumption that something will fit. Components at 17 1/8" and wider are also common, so leave room when planning the width available for components.

We settled on 18" for the inside width of our cabinets. It gave us a little extra room to get components in and out, and works well for our storage drawers. And watch out for the odd component that can ruin everything. Many multi-disk DVD and CD changers are 16 1/2" deep. As with the TV, make up your mind about what components you will have (or will likely add) then design around them.

All of the components and likely several speakers will need to be connected. If you are including space for speaker boxes within the cabinet, make sure you have the space you need. You also need to plan ahead for space to run all the wires and cables.

If your design is extensive, consider making separate, smaller boxes that connect in a unit rather than attempting one giant cabinet. With separate boxes, you can leave space between them to provide wire access and use a wider piece of trim on the front to bridge the space. It's also wise to leave some dead space at the back of all your cabinets to run wiring. Use grommets and cable clips to keep the wires, cables and cords under control and out of sight.

Individual boxes will also help if you are making a built-in that runs from floor to ceiling. Check the diagonal measurement on the side of tall cabinets to make certain you can stand them up without hitting the ceiling.

Before you begin building the cabinets, make note of the locations of any electrical and cable outlets that are in the room, and plan for bringing these into and between cabinets.

Storage for New Media

DVDs and CDs are smaller than LP records and VHS tapes, but still require considerable space. To avoid wasting space, or having spaces that almost work, size any shelves or drawers appropriately. Remember to account for the drawer slides and the thickness of the drawers sides and dividers when designing. Some typical sizes for drawers and shelves are shown in the drawings on the previous page and below.

Applying a Style

When the functional elements have been established, it's time to design the form of the finished cabinet. Think of it as dressing up the basic box or boxes that have been engineered. It's likely that some compromises or adjustments will need to be made along the way, but solving the technical problems first allows you to develop an attractive and practical design.

One of the most popular designs today is a low, credenza-style unit, as seen below. This will provide plenty of storage, and support the television.

We started with the drawers to establish sizes for both the width of the openings in the cabinet,

and the overall height of the cabinet itself. Knowing how much room you need will let you provide a little extra room at the start instead of coming up short at the end. We settled on 18" openings, which works well for our ideal drawer sizes, and also gives some additional space for the component shelves.

If you're making a built-in cabinet, the trim in the room, such as the baseboard, may place some constraints on your design. If you need to raise or lower the screen a few inches from your ideal height it won't make much difference when you're done. Keep your mock-up TV around and check the height again as you put the finishing touches on your plan.

Adding a tower on each side as shown below can provide a more finished look, and can add some handy storage to access your favorites at eye level. You can add some shelves between the towers or hanging above the screen for placing speakers, additional media storage or display.

We used some sophisticated software to develop our design and illustrate this article, but the same tasks can be accomplished with pencil and paper.

The important thing is that a good, functional design is the result of following a step-by-step process. It is like most tasks in woodworking: If you take simple steps in the right sequence you can achieve excellent results. **PW**

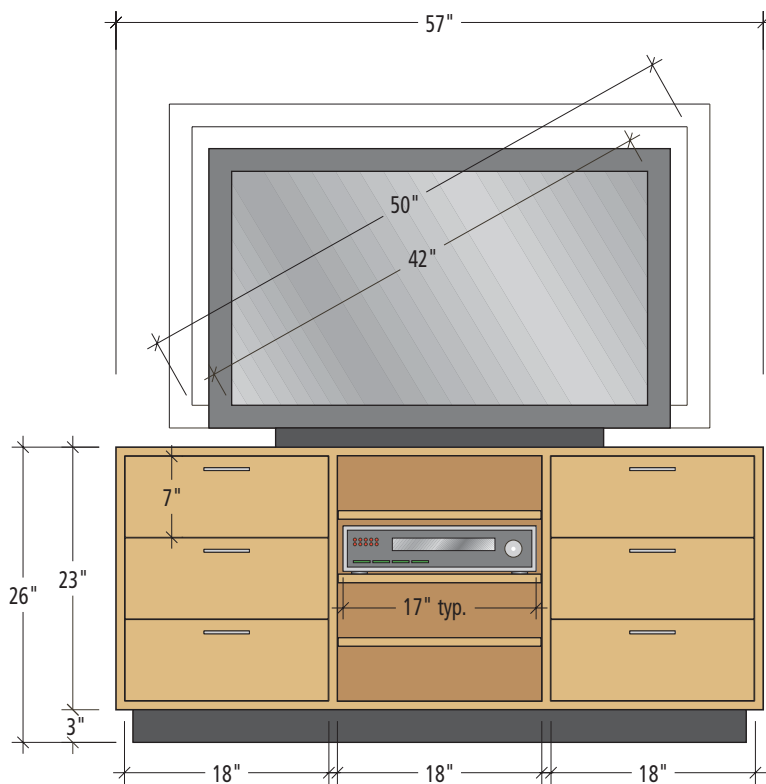

Credenza elevation

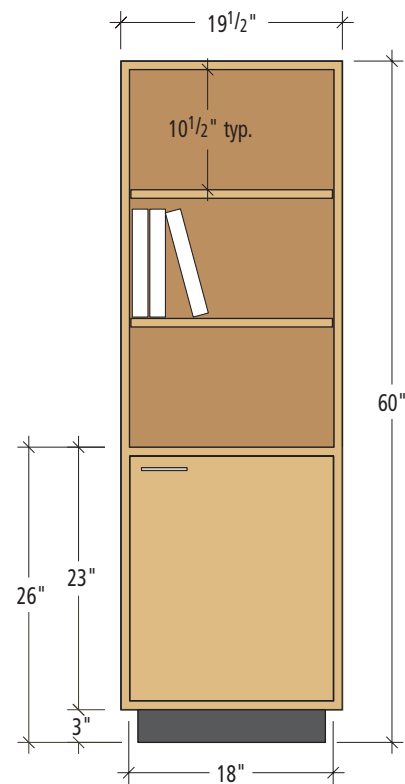

Tall cabinet elevation

After settling on overall sizes, you can start planning specific sizes and shapes, based on components and storage needs. We decided on an ideal width for drawers and shelves that also worked for our components and based the sizes of our boxes on that. Designing in this sequence makes it easy to determine final sizes that work well and look good.

Additional cabinets complete the design. The tall cabinets on either side allow some room to store the old LP records we can't throw away behind the doors, and the open shelves above let us show off some of our woodworking.



A slab from green wood,
some sturdy legs
and a sylvan setting
are all you need.

RUSTIC GARDEN BENCH

“A slab like that can make up into a garden bench. Being white oak, they last.” The sawyer was making conversation while cutting my logs. It sounded interesting. “Well,” I replied, “let’s take a thicker cut next time so I can try it.”

For a suitable slab you need to consider what to look for and where to find it. For size, a 4"- to 5"-thick bark-sided slab taken from a log about 20" in diameter and 4' long will do. Bark tends to slough off in logs cut when spring growth starts, so you might avoid that time of year.

There is a wide range of tree species that can work. I am surprised to find that a free-standing project like this bench will fare quite well when left to weather without any surface treatment.



Photos by the author

This short “orphan” log set on the mill will yield two oak garden benches.

The lumber mill scrap pile may provide the slab top for your bench. Here are discarded bark-covered slabs. You can give it a better life than as a piece of firewood, which it’s destined for now.

The ends of the legs, which stay damp most of the time, will rot, but it is a slow process. I have painted old motor oil on the leg ends to help, but leave the remain-

der to weather naturally. It seems suitable to the project.

Looking at a rot-resistance table in a wood technology book for what species to use would prob-

ably not be of much help since finding a slab is opportunistic. You use what you can find. I have garden objects of walnut, elm, apple, maple and oak, all of which work well. Basswood does not.

Where do you find such a slab, and how do you cut it? Logs are squared up for lumber milling.

continued on page 74

by John Wilson

John operates The Home Shop in Charlotte, Michigan, where he teaches classes and sells Shaker box supplies. Contact: ShakerOvalBox.com or 517-543-5325.

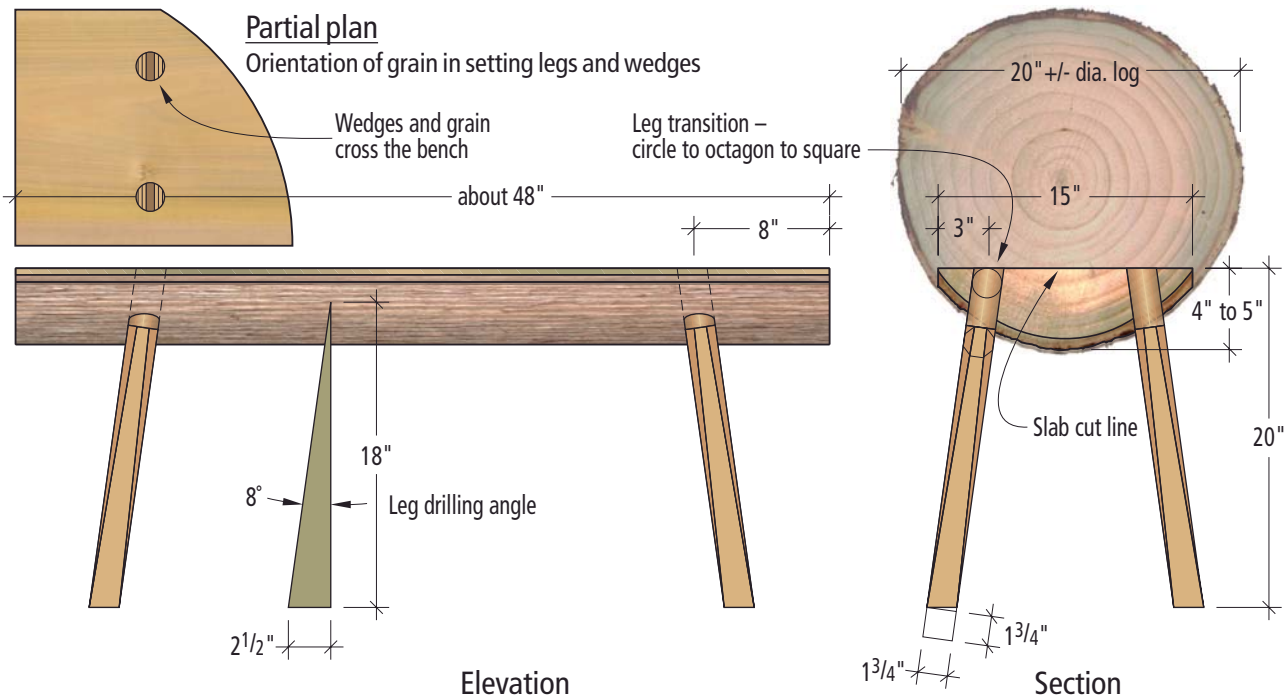



#70661-4 \$24.99



#70505-9 \$24.99

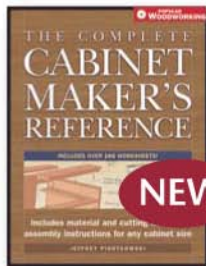

#70710-9 \$29.99



#70691-1 \$24.99

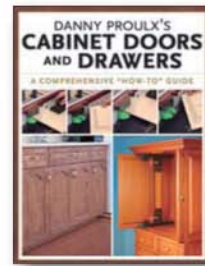

#70692-9 \$24.99

Join WoodWorker's Book Club and CHOOSE 3 BOOKS with a 4th Book for just

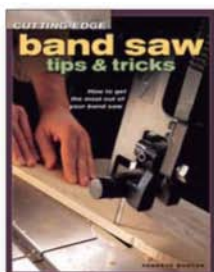

#70653-1 \$24.99

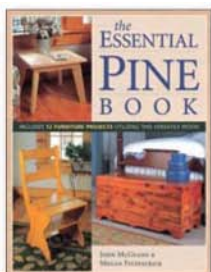

#70663-0 \$24.99

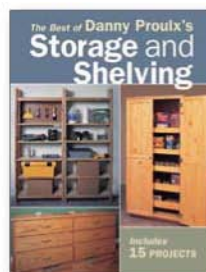

#70684-6 \$24.99

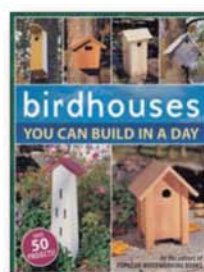

#70656-4 \$24.99

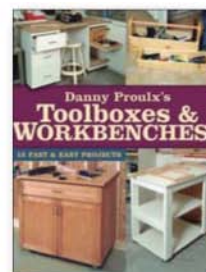

#70659-8 \$24.99

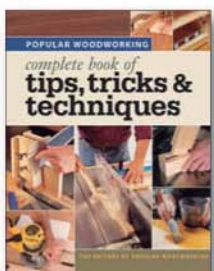

#70669-7 \$28.99 hc

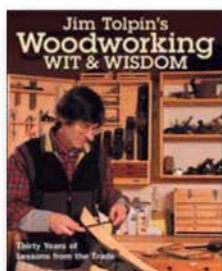

#70672-1 \$19.99



#70607-7 \$24.99



#70552-5 \$24.99



#70626-7 \$24.99



#70491-6 \$24.99

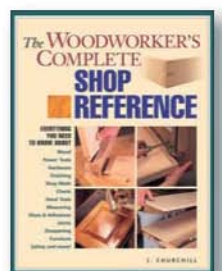

#70579-8 \$26.99

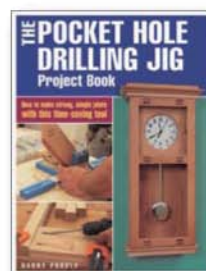

#70637-4 \$24.99

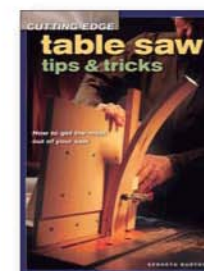

#70569-9 \$24.99

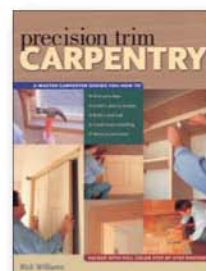

#70584-8 \$24.99

All books are softcover unless marked hc. Prices shown are publishers' list prices.

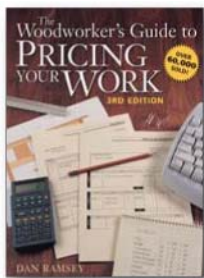

#70690-5 ~~\$22.99~~

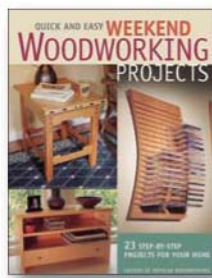

#70698-6 ~~\$24.99~~

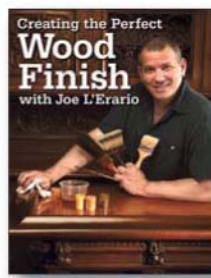

#70697-8 ~~\$24.99~~

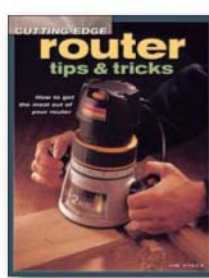

#70649-9 ~~\$24.99~~

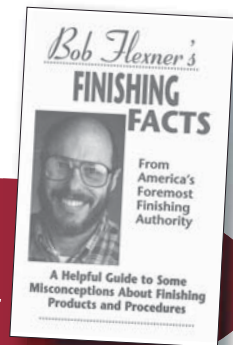

FREE

\$9.99 plus shipping & handling

Plus get a **FREE** Gift

Uncover the secrets to getting the perfect finish — every time! Finishing guru Bob Flexner shows you how. **A \$3.95 value, yours FREE with membership!**

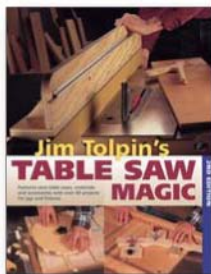

#70627-5 ~~\$24.99~~

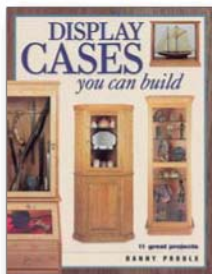

#70547-5 ~~\$24.99~~

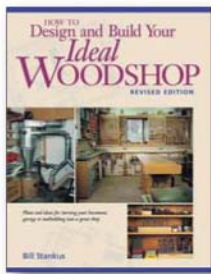

#70522-8 ~~\$27.99~~

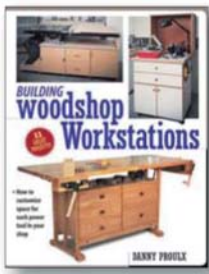

#70585-5 ~~\$24.99~~

Join online @ www.WoodWorkersBookClub.com for an even larger book selection!

How the Club Works

- **FREE CLUB NEWS** About every 4 weeks (14 times per year), you'll receive the NEWS, featuring a Main Selection and 100 or more of the newest and best woodworking instruction books.
- **EASY ORDERING** To place an order or cancel the Main Selection, simply respond online at www.WoodWorkersBookClub.com or return your Selection Card by the marked date. If we don't hear from you, we'll send the Main Selection automatically. On future prepaid orders, shipping & handling is FREE!
- **RETURN PRIVILEGE** If the NEWS is delayed and you ever receive the Main Selection without having 15 days to notify us, you may return the selection at Club expense.
- **NO-OBLIGATION MEMBERSHIP** You have no obligation to buy any more books; you're just agreeing to try the Club for 9 months. After that, you may cancel at any time. Each time you buy a book, your membership will be renewed for 6 months from the purchase date.

WOODWORKER'S BOOK CLUB P.O. Box 9274
Central Islip, NY
11722-9274

1-800-448-0912

Call TOLL FREE Monday-Saturday,
9a.m.-7p.m. M-F 9a.m.-6p.m. Sat EST
www.WoodWorkersBookClub.com

WoodWorker's Book Club is a Division of F+W Publications, Inc.

MEMBERSHIP SAVINGS CERTIFICATE

YES! I want to join WoodWorker's Book Club! Please send me:

My 1st Book **FREE** My 2nd Book **FREE** and My 3rd Book **FREE** with My 4th Book for just \$9.99 Plus My **FREE** Gift
[] [] [] [] - [] # [] [] [] [] - [] # [] [] [] [] - [] # [] [] [] [] - [] # 8 0 3 9 0 - 8

VISA/MasterCard/AmEx Orders Call **TOLL FREE 1-800-448-0912**
9a.m.-7p.m. M-F 9a.m.-6p.m. Sat EST

I'm enclosing \$9.99 plus \$7.99 shipping & handling, for a total of just \$17.98.

Check enclosed (or) Charge my VISA MasterCard AmEx

Acct. # _____ Exp. _____

Signature _____

I have read How the Club Works and understand I have **NO OBLIGATION** to buy any more books.

Name _____

Address _____
(PLEASE PRINT)

City _____ State/Prov. _____ ZIP/PC _____

Offer good for new members in U.S. and Canada only. In CA, CO, GA, MA, MI, NY and OH please add applicable state tax. In Canada provide a street address and remit in U.S. funds; enclose \$10.39 s&h and \$1.43 GST for a total of \$21.81. One membership per household. Allow 3-4 weeks for delivery. The Club reserves the right to approve all applications and may cancel membership at any time.

Mail today to: **WOODWORKER'S BOOK CLUB** • P.O. Box 9274 • Central Islip, NY 11722-9274

ORDER CODE: KAF06PW

SLAB WORKBENCH

Woodworkers in the 17th century and before used a benchtop made from a single thick slab of wood. They were simple but effective benches. The frame supporting it bore the appearance of timber framing for barns and residences. The means of securing wood made much use of holdfasts and wedging because this was before the days of cast iron vises with quick-release jaws.

Techniques shown in the rustic garden bench can be used in fashioning a workbench as well. Rather than a bark-edged slab, the top makes use of a thick plank. The one shown in my bench was a piece set aside at the mill due to embedded nails. When a tree sustains a nail and grows around it, the iron will stain the wood. An alert sawyer will sometimes be able to stop in time before harm is done to the saw. In any event, the remaining cant is a problem. Nails can be dug out, or the problem section cut off. The thick remainder in my bench came from just such an encounter with a nail.

The legs are made and secured in just the same way as for the garden bench. When the slab dries, it will develop cracks that can be filled with epoxy filler. I have used regular epoxy thickened with wood sanding dust, or epoxy products are sold for auto body repair. The wood-colored paste looks better.

The holdfast and vise are made from $\frac{5}{8}$ " threaded rod and wing-nuts. The holdfast goes into a $\frac{3}{4}$ " hole with a nut on the bottom as well as the wingnut and washer for adjustment on top. The vise is easier to make than you may think when you know that threaded rod can actually cut threads in a simple hole bored in hardwood. The trick is that the hole's diameter must match the minor dimension of the rod's threads. I used a $\frac{1}{2}$ "-diameter hole for a $\frac{5}{8}$ "-diameter rod. Drill the hole 3" deep. Put a few drops of oil in the hole. Clamp locking pliers on the end of the threaded rod and turn it into the hole. Hack saw the exposed rod to a length of approximately 5". That's it. The vise jaw is a 2" piece of hardwood with $\frac{3}{4}$ " holes. —JW



A workbench based on the same techniques harkens back to 17th-century craftsmen. The holdfast and vise use $\frac{5}{8}$ " threaded rods and wing nuts. The vise is a 2" oak face with a rod self-threaded into $\frac{1}{2}$ " holes.



Trimming the top to size can involve a variety of tools: table saw, circular saw or chain saw. Leave an edge about $1\frac{1}{2}$ " wide.



To achieve the desired leg splay, use a level on top of a board cut to the ratio of $2\frac{1}{2}$ to 18". This is the angle both end-to-end and side-to-side. The heavy slab rests on wood blocks to steady the drilling with a $1\frac{3}{4}$ " Forstner bit in the drill press.



Prepare the legs using a V-notched board and a stop block. Plane the 2" x 20" squares so the bottom remains square and the top end is octagonal.

continued from page 71

What you want is a slab from the bark edge that is 1" to 2" thicker than normal. Another way is to chain saw a slab from a 4' section of log destined for firewood. All that remains to be done is to trim an inch off the sides to give a plank 12" to 15" wide.

The bench's top is made green. The holes tighten on the legs that way. There are two ways of doing the leg joint. One is to through-drill and wedge the leg end. The other is to drill a socket that does not come through the top surface. You need to accurately size the tenon end of the leg with this method. I use a rounder plane to give accurate tenons, but careful planing is possible with the use of a hole gauge made from a board drilled with the same drill as used in the bench's top.

When the through-hole method is used, you can beat the leg into place until tight, then wedge the end to lock it. That makes it more forgiving of tenon preparation. Shop tip: If you choose the through-hole-and-wedge method, have the grain of the leg run crosswise to the length of the bench, and the wedge do the same (see the illustration on page 71). My project used the hole-not-drilled-through method, and legs made from fairly dry wood.

The challenge of making this project is drilling the holes. You need a large drill, the angles are a bear and the slab is heavy. In fact, a green-wood slab is as heavy as an 80-pound bundle of shingles. For through-drilling, a 1" auger may be your largest, but larger is preferred. For drill press drilling of socket holes, I used a 1 $\frac{3}{4}$ " Forstner bit. (Be sure there is room around your drill press for drilling all your holes!) The hole angle is critical for any chair or bench. I used a splay in both directions of 2 $\frac{1}{2}$ " in 18". In the drill press, block up support for the slab and use a short

level to achieve the correct angles. In hand auger drilling, cut a scrap of plywood at the 2 $\frac{1}{2}$ ":18" run and rise to guide your drill.

The legs are square at the bottom and octagonal at the top. I cut the legs from a rough 2 x 4 of white oak that was fairly dry. The actual dimensions were slightly more than 1 $\frac{3}{4}$ " x 1 $\frac{3}{4}$ " square, left rough, and cut to 20" length. Plane the edges from nothing at one end to a flat sufficient for one octagon surface at the other. Shop tip: A board roughly $\frac{3}{4}$ " x 6" x 12" with a V-notch 1 $\frac{1}{2}$ " deep on one side when clamped in your bench vise will hold the leg steady for planing. Clamp a stop to your bench for the other end of the leg. Now form the tenon using a hole gauge and block plane or a rounder plane.

However you join the legs, the last step is to block up your bench level to the floor, and mark the ends for cutting the legs to the correct length and angle. Use a small wood block to guide your pencil, or a scribe (aka compass) to mark all around the leg ends. Cut to length. Plane all edges of the bench's top and legs for comfort and enjoy. **PW**

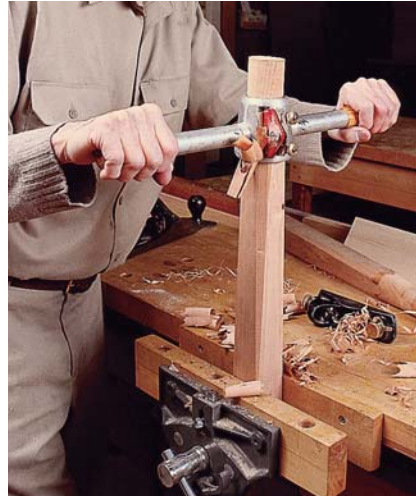

A rounder plane is a traditional tool for making tenons. They are made in a variety of sizes for chair posts and rungs as well as sizing tenons. This is a modern metal-bodied plane based on traditional wooden ones from Ashem Crafts in England. Visit ashemcrafts.com for more information.



If you don't own a rounder plane, you can use a block plane to form the tenon. Whichever method you choose, use a hole gauge to check the tenon's size.



Hammer the legs into place. With this version of the garden bench with stopped holes, no glue or wedges are necessary, as the legs, being drier than the slab top, will hold tight as the top dries.



The final leg length is marked by leveling the bench (note the use of wood scrap under each shorter leg) and marking with a scribe. Cut along the lines and plane all sharp edges as the final step.

Trim Routers

Born out of the laminate industry, these routers are great tools for all kinds of woodworking projects.

I've been using these small trim routers for decades, having first used them in the industry they were developed for: laminate work. I can't say I miss the laminate work, but it didn't take me long during my preferred woodworking tasks to realize that I missed the convenient size and abilities of a laminate trimmer. Who says they're only for laminate?

Though limited to 1/4" shank bits, these trimmers are true routers. They're capable of joinery work and edge details just like a standard router, but also offer benefits not found on a standard router. Their small size makes them ideal for detail routing such as inlay work and small hardware installation.

In addition, many of these routers are available as kits that include multiple specialty bases. Most kits include a traditional flat base and an offset base that allows a power transfer from the main spindle to an offset collet for routing into tight corners. A third base is a tilting base that allows routing at angles. This opens up lots of new opportunities for customized profiles, as well as angled grooves and more. The kits can almost double the price of the router, but it more than doubles the applications possible with the router, so it's worth considering.

Testing

To test the routers we used three different operations using new bits from Infinity Tools (infinitytools.com). We ran a 1/4"-radius roundover bit along the edge of an 18"-long Lyptus board, checking the amperage draw during the cut.

One of the most common knocks against trim routers is that they're underpowered. To see if that

by David Thiel

David has been an editor with Popular Woodworking for more than 10 years and is also the host of Tools & Techniques on the DIY network. Comments or questions? Contact David at 513-531-2690 ext. 1255 or david.thiel@fupubs.com.



Photos by Al Parrish

assertion was valid, we slipped a $\frac{3}{4}$ "-diameter dadoing bit into the trim routers and ran $\frac{1}{4}$ "-deep dados across a 12"-wide mahogany board in a single pass.

Our third test was to gauge the ease of fine work with the routers. Their small size makes them ideal for this work, but if you can't see where your bit is cutting, it's not that helpful. We ran $\frac{1}{8}$ "-deep hinge mortises in the Lyptus boards, again using the $\frac{3}{4}$ "-diameter dado bits.

We also spent some time gauging the ergonomics of the tools. In particular, how the router felt in the hand, how it balanced and how easy it was to change bits and adjust the depth of cut.

Features and Comments

There were a number of features to help contrast the nine routers in the test. Two of the routers (Bosch and Ridgid) included variable-speed control, while all the others were single-speed models. While these routers are somewhat limited in capability by their motor sizes, they can use large-diameter bits (if the base allows enough clearance). When using a large bit, slowing the speed of the router will improve the cutting performance of the bit. That said, variable speed is a nice feature, but not a deal-breaker in this category.

A soft-start motor is a side benefit of the variable speeds on the Bosch and Ridgid units, but the Makita also includes a soft-start feature. This is a handy feature because of the power packed into these pint-sized routers—there can be a significant jerk as the centrifugal motion kicks in. Soft start allows you to more easily control the router during delicate procedures (such as inlay work) and it makes the tools more pleasant to use in general.

Related to the capability of each router is the base opening size. We've noted the range of opening sizes in the chart. Some of the router bases are designed to accept template guides, so the base opening is sized for that feature. Two of the routers (Makita and Grizzly) actually come with a template guide.

While the motors do much of the work on these routers, the bases make them accurate and affect the ease of use. There are a variety of bases used in the test routers. The most common is a base that slips over the motor housing and clamps in place against the body. The depth of cut is adjusted by sliding the base up or down the motor body. Six of the nine routers use this design, though each of those six have differences. Some have bases that orient or align to the motor, and some offer gross or fine depth-of-cut adjustment (or both). Another difference is how easy it is to lock in that adjustment.

The other three routers (DeWalt, Freud and Porter-Cable) use a base design that clamps the base to the motor housing and the depth of cut is controlled within the base itself, independent of the positioning on the motor body.

Another interesting feature about the bases relates to visibility. Some of the bases (the base body, not the base plate) are a high-impact polycarbonate, while others are metallic. The polycarbonate bases are translucent or transparent, with differing results. More important than the type of material used is the way the base is cut away around the bit. A more enclosed base dramatically reduces visibility.

The switches for these routers are all over the place. Some on top, some on the side—and when



We tested all of the routers with the standard base attachment, but many of the trim routers are offered in kit form with multiple bases. The two most common accessory bases are an offset base (at left) and a tilting base.

on the side, they can be either at the top or bottom of the router. Because trim routers are primarily one-handed power tools the switch position isn't as critical as on larger routers. But you may very well prefer one switch location over another. We'll leave that decision to personal choice.

Conclusion

We based our conclusions solely on the standard routers, not on the extra bases offered in the kit versions. Though we feel these extra bases offer significant benefits, not all the trim routers in the test included multiple bases, so we felt it inappropriate to consider them in forming our conclusions.

While the power offered by each of these routers is important, we found that the ease of use (depth-of-cut adjustability and visibility) were much more important factors.

In considering power, the routers range from 2.1 to 6.5 amps, with the Grizzly standing as the lowest router on the totem pole at a mere 2.1 amps. During our dado testing we pushed the routers beyond what would be appropriate use and found the power in the Bosch, DeWalt, Makita and Ridgid to be the best. All the other competitors fared well, but we noticed bogging in the Freud and Grizzly units.

In depth-of-cut adjustment we found the Bosch the best of the

bunch with easy to use gross and fine adjustments. The Makita and Ridgid models offered better-than-average depth-of-cut adjustment, while the rest of the group ranged from average to awkward.

Visibility was another tricky one. While you might assume that the translucent bases would improve visibility, the plastic isn't clear enough to actually provide improved visibility. It does improve the light available at the cut, but the more important factors were the hole size and the way the base was cut/formed to allow actual visibility. Bosch won again in this department with a well-designed base cut nearly half away and a larger-than-average base opening for bits. Close behind was the Makita with a clear base, good cutaway and an added task light to help out visibility.

Considering all these factors and more, we awarded the Bosch the Editor's Choice Award in the trim router category. The Makita offered good performance, though slightly less user-friendly depth-of-cut adjustment. Tipping the scale for the Makita is the built-in work light, earning it a second-place finish.

While the Grizzly H7790 was significantly less expensive than the other routers in the test, we didn't feel that its performance and ease of use gave it enough of an advantage to call it out as a winner based on price.



BOSCH PR20EVSK

This router has the best feel of any we tested. The grip is a comfortable size and the soft rubber wrapped on the body provides a good grip and reduces vibration transferred to your hand. It's also one of only two routers with variable speeds.

The base has the benefit of both a gross and fine depth-of-cut adjustment that can be switched back and forth with a slight turn of the base. Very nice. The base attaches and locks in place on the motor easily with a quality turnbuckle latch. The fine adjust on the base is the only one in the test that calls out the adjustment range (one turn equals 3/64"). Changing bits is made more convenient with the tool's spindle lock, which is easily accessible. The soft-start feature also adds to the user-friendly feel of this tool. During testing we found very good power and performance. Visibility was very good, but we wouldn't mind if they added a work light like Makita has. While it's not a comment that we can support with numbers, the Bosch trimmer "felt" more smooth and solid during testing, giving a quality feel to the tool, which earned it our Editor's Choice Award.

The router as tested comes with a straightedge guide and plastic case. Available bases include offset and tilting, as well as bearing-guided accessories and a laminate seaming plate.

boschtools.com or 800-267-2499



CRAFTSMAN 27715

The Craftsman is one of two nearly identical routers in the test (compare it to the Ryobi).

Overall we like the size and feel of the Craftsman and we were initially pleased with the thought of the translucent base with a smoky finish. Unfortunately, we found that translucency didn't translate into improved visibility. The base design has the base slipping over the motor to adjust the depth of cut and uses a convenient turnbuckle latch. Unlike some of the other "slipover" bases in the test, the Craftsman base does orient on the motor using a pin guide on the motor. However, we noticed that the guide channel in the base collected dust during operation, making the base difficult to adjust. Only gross height adjustments are possible with this router and we found that the balance of tight-fit and easy depth-of-cut movement was very tricky. When the adjustment was smooth the base would slip during operation. Not good. Considering the \$100 price we would have liked to see a collet lock on this router, and we would certainly expect a base that doesn't slip during operation.

As tested, the Craftsman trimmer comes with the standard base and an oversized wood-working base with two large handles. Also included is a flush-trimming bit with bearings. No accessory-base kit is available.

craftsman.com or 800-549-4505



DEWALT DW670

The DeWalt is one of the three routers in the test that uses a non-slipover base design. This offers a fine-adjustment feature (though without graduated indication of depth change), but no gross adjustment for depth of cut. The DeWalt design uses a toolless attachment for the base, but this adds a rather large handle that is in the way. While the DeWalt includes a spindle lock to assist with bit changing, the base really needs to be removed to adequately access the collet lock.

The grip size is OK, but there was little attention given to ergonomics. During testing we found the DeWalt to have good power, but the base design makes it very difficult to see where the cut is taking place. The hole is small and because the base offers only fine adjustment there is very little travel in the base, making it a very short opening with poor visibility. The DeWalt was also the loudest router in the test, making it less appealing. But in short, the DeWalt isn't a bad choice. It has some upgraded features (a spindle lock and toolless base attachment), but they're cumbersome to use. Essentially this is a tool that could benefit from a redesign.

As tested, the trimmer includes the standard base and a bearing guide. The kit includes standard, offset and tilting bases, a laminate seaming plate and edge guides.

dewalt.com or 800-433-9258



FREUD FT750T

The Freud is similar to the DeWalt in design, with the base attaching to the motor body. Unlike the DeWalt, the Freud requires a wrench to tighten the base and does not offer a spindle lock. Like the DeWalt, the base design offers only fine depth-of-cut adjustment and has no graduated depth indicator. The base offers slightly better visibility than the DeWalt, and adjusting the depth of cut is a smoother operation with the Freud.

Power, on the other hand, was not as good as the DeWalt. While both the Freud and DeWalt are larger than most of the trim routers in the test, the Freud has the unpleasant distinction of the being the tallest, giving it an ungainly feel in the hand with a penchant toward tipping during operation. While priced competitively with most of the pack, the Freud router is lacking in features, ergonomics and power. This is another tool that could benefit from a redesign.

The Freud trim router is sold only as tested with a standard base, case and bearing edge guide, though tilting and offset bases are available as accessories.

freudtools.com or 800-334-4107



GRIZZLY H7790

The Grizzly is the no-frills router of the test. It is an older design with the only metal-motor body in the group. It's also missing some user-friendly features that, combined with its affordable price, would have given it a nice edge in the review.

We found the power limited as we pushed the router during testing. The base is not fixed in relation to the motor and only offers gross depth-of-cut adjustment. The base-mounting mechanism (a two-handed thumbscrew arrangement) is awkward, requiring both hands to tighten the base and a third hand to maintain the depth-of-cut adjustment. One feature that is solid on this router is the visibility at the base. The clear base and cutaway design offer nearly identical visibility as the Makita (but without the work light), which is very much appreciated. As to ergonomics – well there wasn't much effort exerted there. The router size is OK, but it feels odd in your hand, with no obvious place to grip the tool. In addition, the top-mounted switch hinders convenient bit changing. While the price is tempting, we'd suggest spending more for a better tool.

The Grizzly comes with the standard base, an edge guide, template guide and a bearing-edge guide. No additional bases are available.

grizzly.com or 800-523-4777



MAKITA 3707FC

The Makita router is an odd mix. The base is a slip-fit design that offers gross and fine height adjustments, using a slip sleeve and a pressure roller wheel mounted on the base. The fine adjustment is there, but not as refined as on some other routers in the test. The base attaches to the motor body effortlessly with a simple turnbuckle latch and is transparent and cut away, which offers good visibility. For even better visibility, Makita added a pair of task lights that shine directly on the work surface. The router has a comfortable, slim grip and some attention was afforded to ergonomics.

During testing we found the Makita to have reliable power and the quietest operation of any router in the test. The Makita is comparable in performance and visibility to the Bosch, earning it an Editor's Choice Award. The fine adjust is less convenient than on the Bosch, and we would have liked to have a spindle lock. That, mixed with the highest price in the test, makes it finish in second place behind the Bosch, but still worthy of recognition.

The Makita comes with a standard base and bearing-edge guide, and a template guide. A tilting base is available as an accessory.

makitatools.com or 800-462-5482



PORTER-CABLE 7310

The Porter-Cable router is most similar to the DeWalt and Freud base designs, employing a base that mounts to the motor (with a knurled knob), but doesn't slip on the motor housing for depth-of-cut adjustments. As with the two similar routers, this base design offers only fine depth-of-cut adjustment. The Porter-Cable does offer a smaller motor housing making the router easier to handle during operation but still offers little in the way of ergonomics. The flat top and conveniently located spindle lock allow for convenient bit changes.

Power during testing was below expectations with some bogging during the dado cuts. Visibility was poor. The base offers only a short area to see past and a small, dark hole through which to see. The base adjustment was better than some in the test, but still not great. For the base to move, the locking knob has to be slightly loose. This leaves play that allows the base to wobble during tightening, throwing the setting off by 1/16" or more. When compared to the similarly priced models in the test, the Porter-Cable tool falls short in performance and visibility.

As tested, the router includes the standard base. Offset and tilting bases are available in kit form.

porter-cable.com or 800-321-9443



RIDGID R2400

One of only two variable-speed routers in the test, the Ridgid has a very slim design that is comfortable in the hand, and some attention has been paid to ergonomics. The base is the only (standard) round design, with a rack-and-pinion height adjustment that allows for gross and fine adjustments, though the fine adjustments are tricky to control. The thumbscrew lock on the base tends to compete with the fine adjustment function. Though the switch and cord aren't mounted at the top of the router, the top is sloped so bit changing isn't made any more convenient. The router also requires two wrenches to change bits, and one of the wrenches provided was slightly undersized making the process frustrating.

During testing we were pleasantly surprised by the power offered in such a small package. On the opposing side, the base design makes visibility difficult. This is the first trim router manufactured under the Ridgid name and while they got a number of things right, we still see room for improvement.

The router comes with a bearing-edge guide and fixed-edge guide. No accessory bases are available for this model.

ridgid.com or 866-539-1710



RYOBI TR45KT

This router is a nearly exact copy (physically) of the Craftsman router. The one significant difference is the color of the translucent bases. The Ryobi base is yellow, which is an improvement for visibility over the gray, smoke-finish Craftsman base. The base slips over the motor to adjust the depth-of-cut. The Ryobi base suffers from the same slipping/tightening difficulty found in the Craftsman model, making easy adjustment a trade-off for slipping during operations.

Performance was slightly better than the Craftsman during cutting, and as mentioned, visibility was slightly better. One obvious benefit over the Craftsman is the \$20 savings. Unfortunately, that still leaves it at an \$80 price which doesn't make up for a balky base attachment, minimal features and less-than-perfect visibility.

One caution about the Ryobi (and the Craftsman clone) is that the collet is an integral part of the motor shaft. If you wear out the collet on one of these, you can't easily or affordably replace it.

The Ryobi trimmer comes with the standard base and an oversized woodworking base. Also included is a flush-trimming bit with bearings. No accessory-base kit is available. **PW**

ryobitools.com or 800-525-2579

TRIM ROUTERS

	Bosch PR20EVSK	Craftsman 27715	DeWalt DW670	Freud FT750T	Grizzly H7790	Makita 3707FC	Porter- Cable 7310	Ridgid R2400	Ryobi TR45KT
Price *	\$115	\$100	\$100	\$100	\$40	\$130	\$93	\$100	\$80
Amps	5.7	4.5	5.6	6.5	2.1	4.4	5.6	6	4.5
RPM	16k-35k	25k	30k	30k	30k	26k	30k	20k-30k	25k
Spindle lock	Yes	No	Yes	No	No	No	Yes	No	No
Base opening	1 1/2"	1 3/8"	1 3/16" *	1 1/8"	1 5/16"	1 5/16"	1 3/16" **	1 1/8"	1 3/8" **
Edge guide	Yes	No	No	No	Yes	No	No	Yes	No
Weight	3.8	3.2	4.1	4.2	3.9	3.2	4.0	3.6	3.1
Height adj.	G/F	Gross	Fine	Fine	Gross	G/F	Fine	Fine	Gross
Height	7 1/2"	7"	8 1/2"	10 1/2"	6 1/2"	8"	7 1/2"	7 3/8"	7"
Amp no-load	2.3	1.9	2.8	1.8	2.2	1.8	2.1	2.4	2.1
Amp load	3.4	3.3	3.4	2.6	3.1	3.1	2.9	3.5	3.2
Amp change	1.1	1.4	0.6	0.8	0.9	1.3	0.8	1.1	1.1
Soft start	Yes	No	No	No	No	Yes	No	Yes	No
Decibels	87	82	93	88	91	78	87	84	81
Cord length	10'	10'	9'	8'	8'	8'	10'	12'	10'

*Prices from Amazon.com where available.

**Opening sized for template guide.

WHAT'S NEXT?

As trim routers begin to gain respect as routers, not just trimmers, it's natural to consider where they're headed as a category. If you compare the differences between the recently redesigned Bosch trim router and the dated but functional Grizzly trimmer, you can see that things are changing.

While the addition of better depth-of-cut adjustment, better visibility and improved bit changing are very much welcome, there's more to come. One of the features that makes trim routers appealing to me is the addition of specialty bases giving the trim routers more versatility than standard routers. So why not add another base to the mix?

We welcome the plunge base for trim routers. There are a couple of examples of smaller routers with plunge bases such as the Grizzly H2854 (\$69.65) shown at right and the Dremel plunge-base attachment. The Grizzly (and other similar models) uses a grinder motor body giving it a different feel than a true router, but you still get the benefits of a plunge base in a smaller router. The Dremel almost works, but while acceptable power is a concern for trim routers, it's even more so for rotary-style tools when used as a router.

Not to worry. Just last year MicroFence introduced a Portable Three Axis Mill designed to bring precision plunging capabilities to a selection of trim routers as an accessory. We've tested the mill (April



The Grizzly H2854 offers plunge-base convenience in a trim router size.

2006, issue #154) and it's very precise and a nice addition to a trim router. It's also a bit of an expense — at \$400, the accessory is four-times the cost of most of the routers in the test.

For those interested in a more affordable option, manufacturers such as Bosch are looking at adding a plunge base to their trim router line. We're glad to hear it and as soon as we have more information we'll pass it along to you.

—DT

From Wood Chunk to Chuck

The best way to process logs into blanks and avert future headaches.

Ideally, your turning wood comes to you in one of two ways: as fresh, sound green wood, in reasonably sized sections that you quickly rough-turn into bowls and/or cut into smaller, sound pieces to suit your particular needs; or as nicely cut-up, already dry (or wax-coated and therefore stable), sound pieces in sizes that suit your particular needs.

In real life, however, you'll most likely end up with a hodgepodge of wet, damp, semi-dry, somewhat-damaged, dry-but-with-cracks, and other categories of wood, some of it in nice tidy logs or squares, but more of it in odd chunks and shapes that don't even make sense as firewood. In consideration of the fact that you don't necessarily know right now all of the types of turning you will ever want to do, you may legitimately choose to leave some of this wood in its original format, just in case you might someday want an odd-shaped piece, or one with bark on one side and a saw cut on the other, or whatever.

But generally speaking, it's a good idea to go ahead and cut up most of this wood into somewhat standard pieces, which you can then dry and store properly. "Properly" means in a way that preserves the material from further deterioration, and allows you to easily find what you are looking for when you need it.

Because your needs are probably different from mine, you may make different cutting choices as you process your own wood, but a few principles will almost always apply. Usually you will want to keep pieces as large as possible because you may need a large piece in the future. That is, don't cut a 2" x 2" x 20"-long square into 2" lengths; perhaps you are making a lot of bottle stoppers now, but you might want to make a tool handle later on and you'll want that length. You can cut the piece shorter any time, but it's hard to put it back together.

A large piece of log that has been sitting for a long time should probably be cut up when



Photos by Al Parrish

The large size and weight of this beech log make it stable enough to cut without additional support. Slice a piece off of one end to find out how deep the checking goes. Sometimes there are many cracks that go the whole length of the piece, rendering it useless. More often, it's possible to cut past some of the cracking and salvage useable pieces.

you acquire it. Either it is still fairly wet, in which case you should process it as green wood (see "Preparing Green Wood," February 2006, Issue #153) before it begins to deteriorate; or it is fairly dry, in which case it will have at least some cracking, and you may as well cut it up

and see what's in there. If it's ruined, you can burn it or discard it and you will never again have to stumble over it. If it contains sound wood, you'll know what you've got and can prevent further loss.

You may not always know what to do with an odd-shaped piece, and if it's stable there's no intrinsic reason to cut it immediately. But getting in the habit of processing most of your found wood quickly will save you time, trouble and wasted wood in the long run.

Keep in mind the sawyer's job is the most

by Judy Ditmer

Judy, author of two turning books and many articles, has been turning since 1985. She teaches and demonstrates her skills throughout the United States and Canada.

AT THE LATHE

skilled one at the mill. As the sawyer in your mill, you have to take into account many factors, including the nature of the material, loss prevention, types of stock needed or possibly needed, how much space you have for storage, and others. With experience, you'll gain confidence about how and what to cut, based on a growing understanding of what is in the log to start with, and what kinds of things you expect to do with the wood later. **PW**

Assorted wood piled near the band saw, ready to be cut. I often acquire the odd chunk of wood that has been sitting for some time. Most of these have some splitting and aren't suitable for bowls of any size, but often they yield a lot of useful wood for smaller projects.



Small round pieces, such as limbs, need to be stabilized before running them through the band saw, or they may twist when the blade enters the wood. This can ruin a blade or, worse, injure you. A simple way to do this is to clamp the piece in a large handscrew clamp. Notice the saw's large table; the extra room provides a convenient "staging area" for cutting up large pieces.



The inside surface of this 2"-thick slice shows quite a few cracks, so I'll take off another slice before cutting the piece lengthwise. The idea is to get past most of the cracking.



Cutting the piece lengthwise. A second slice off the end revealed a fairly clean surface; I then cut off the other end to leave a piece as long as its diameter. This will make two good-sized bowl blanks if the inside of the piece is sound.



This half has a large split along the center, so I'll cut it into smaller pieces. It will still provide lots of nice squares for tool handles, boxes, candlesticks, bottle stoppers and many other items.



I'm cutting a small slab from half of the piece. This could be used for small bowls, or further cut into squares for spindles.



I cut still smaller squares and slabs from the scraps of the larger pieces, and pile the cut wood to the right.



Typically, I slice off at least 2" from a large limb or log, because I find I can often cut around any cracks to get a number of bottle-stopper blanks from such a piece. These short squares can also be used for boxes, tops, ornaments and so on.



Even quite small slices ($\frac{3}{4}$ "") can be useful if the wood has nice color and/or grain. Don't forget pens, fan pulls, tops, etc.



A decent supply of sound wood cut from a log that appeared quite damaged. If wood prepared like this isn't completely dry (i.e., dry enough to be stable in the conditions in which you will store it), you should coat the end grain with green wood sealer before storage, to prevent new cracks.

ORGANIZATION AND STORAGE

As a turner making a wide variety of items, from large wall pieces to tiny finger tops, I use a huge variety of types and sizes of wood. It's important to be able to find what I need for a given project without wasting a lot of time rooting around in amorphous piles of material. Toward that end, a few years ago, I embarked on a summer project to upgrade the mishmash of block-and-board shelves, bins, boxes and piles of wood to a reasonably concise storage system. The heart of it is a number of industrial wire shelving units, along with cardboard boxes purchased to fit exactly on those shelves. Also important are wire-drawer carts for the initial drying of any wood that is too wet to be boxed or closely stacked.

It's not a terribly strict system. Things are grouped in ways that make sense to me; a shelf for dogwood, one for local exotics, one for Florida roadkill wood, another for exotic exotics, etc. This allows me to find suitable pieces very quickly for just about any project I have in mind, and to notice if I am running low

on something that I use regularly.

Of course this organization project took longer than I had anticipated, possibly due in part to my excessive delay in starting it.

You may wish to undertake a similar venture before 15 or 20 years of accumulation – if it's not already too late for that. — JD



Wood that is dry (or very nearly so) goes into labeled boxes. Wet wood goes into wire carts for a time before storage. When the boxes are full, or when I have no more wood of that type to be cut, I move them to shelving in another room.



A view of part of my wood storage room. These wire shelves are the cat's pajamas. They are very strong and allow for air circulation. The boxes contain smaller pieces of wood that are dry (or at least dry enough not to mold). Rounds and short boards are shelved like books. Longer boards are slid in from the ends.

Thick, short slabs are shelved like books and labeled. This saves me a lot of time when I'm looking for a particular species. (I won't say how long it took me to get around to the labeling.)



Very large or long boards are stored upright in racks. (The really long 4/4 boards, left over from my past days as a cabinetmaker, are stickered on the left.)

Craftsmanship Done Safely

Kelly Mehler's school refuses to sacrifice proper guarding when teaching proper woodworking.

Woodworking teacher Kelly Mehler got his start in the schooling business in an unusual way. His first teaching job was to instruct patients at a rehabilitation center in woodworking basics using simple machinery. While working there, he took classes in the wood technology program at the Ohio College of Applied Science, which helped cement his interest in the craft.

"I looked all over Cincinnati for someone to apprentice under," said Mehler, "but there was no one." Thus, in 1976 he and his wife, Teri, packed up and moved south to Berea, Ky., where Mehler began his pursuit of a degree in industrial arts at Berea College with the intention of teaching in a vocational school and making custom furniture during the summer. Instead of completing the program, he headed out on his own to make custom furniture, and he put the teaching on hold for a while.

He began his career as a custom-furniture maker in 1978, in a shop he converted from an old barn in Mt. Vernon, Ky. Before moving in his equipment, he first had to pour a concrete floor and cut in windows. "It turned out to be a good sized, efficient workshop," said Mehler, even if the air and heating left a bit to be desired. While he struggled to get the furniture business off the ground, Mehler spent a lot of time at juried craft fairs, which he used as a springboard to generate custom orders. He marketed a line of desk organizers, quilt racks and other items appropriate for the craft-fair market, but also took along one-off furniture pieces and his portfolio to show alongside the smaller items.

While the fair circuit was difficult, Mehler said there were many rewarding moments.



Photos by Al Parrish

Kelly Mehler (left) works with John Tuohey, of Chevy Chase, MD, on a Shaker table. This was Tuohey's second visit to Mehler's school, and he plans to return during the 2006 season. "I love the shop setup here," says Tuohey. "And, his explanations are so lucid. If you can't get it from Kelly, you can't get it."

"You got to see you weren't the only one struggling. When you're by yourself, you think it's you, but spending time with other craftspeople helped me realize they were struggling, too," he said. But the most important lesson was in creating production-line items. "The repetition builds skills and at the same time presents the challenge to maintain the quality of each piece – that teaches you a lot," said Mehler. Eventually, through the contacts he made at

the fairs, the demand for Mehler's custom-furniture work increased, and he began to realize his goal of full-time custom work.

After two years in the Mt. Vernon shop, Mehler moved his business to a former car dealer's building in Berea, where he remained until 2004. While building his custom furniture business, Mehler had many requests to teach. But he knew education wasn't a job to take lightly and his business wasn't set up for teaching. The space was great for building, said Mehler, but not for students. So, he honed his teaching skills through presentations to various woodworking guilds, and wrote arti-

by Megan Fitzpatrick

Comments or questions? Contact Megan at 513-531-2690 ext. 1348 or megan.fitzpatrick@fwpubs.com.

cles for a number of woodworking magazines. Then, he recorded a video for The Taunton Press on building a Shaker table, and that led to a video on the table saw. “Before I knew it, I was ‘the table saw guy,’” he said.

Because of all his research, Mehler developed a deep understanding of the safety aspects of the table saw, and learned what it would take to make the machine safer. “That gave me a sense of responsibility. There was so little safety information – nothing of substance – so I felt I should publish what I’d learned, and work toward getting things changed. He’s since written (and then revised) the landmark “The Table Saw Book” (Taunton), and has helped to develop new table saw safety standards for Underwriters Laboratories.

Safety is of utmost importance to Mehler, and he’s troubled by the practices of many woodworkers. “Most people are not safe at the table saw, because of their role models,” he said. “They’ve been shown unsafe practices and they know it’s scary, but think, ‘that’s just the way it is done.’” His hope is that the new regulations, which provide a better guarding system, will make it easier for woodworkers to start using guards regularly. “My goal is to do what I can to change the culture,” he said.

After 10 years of teaching at woodworking schools and shows, Mehler has reached a lot of people with his message of table saw safety; it’s a litany he now preaches at his own school, Kelly Mehler’s School of Woodworking. The custom-built school opened in 2003, and is located on 10 acres at the base of an Appalachian foothill, a few miles outside picturesque and quaint downtown Berea.

Classes run from April through October, and usually consist of no more than eight students, which Mehler said is one of the strengths of his school. “It’s a laid back, friendly atmosphere, where instructors can provide each student with a lot of individual attention,” he said. Developing such good working relationships is important to Mehler, because he feels students are more apt to learn when they’re relaxed and comfortable. “When they have the teaching they need, they can blossom even more,” he said. And to make sure they have the teaching they need, Mehler hires expert guest instructors to supplement his own expertise and experience.

Finding interesting projects that dovetail with the skills being taught in a classroom



Mehler’s two-story school is constructed and situated for maximum energy efficiency, with large, south-facing windows for maximum natural light, thick walls for good insulation and high ceilings to disperse excess heat. Next to the two-story shop sits a 19th-century Kentucky box house, which has been rehabbed with all the modern conveniences. While visiting instructors get first dibs, the cozy house is available for student rental.

setting is a major part of Mehler’s job. His challenge is to decide on projects that provide opportunities to teach a wide variety of hands-on woodworking techniques. “That way, my students are learning a particular kind of furniture construction that just happens to be part of (the project),” he said. “The end product is really the vehicle for learning

fundamental techniques that prove useful across many projects.”

His teaching method is a balance of group explanations and one-one-one instruction. For each step of a project, Mehler gathers his students together for a hands-on demonstration, then sets them to the task while offering assistance where needed. All the while,



Here, Mehler shows his students how to run tapered legs on the jointer.



Mehler chose this Felder combo machine (jointer, mortiser, sliding table saw and shaper) because he insists that it incorporates superior safety features.

Mehler and his shop assistant keep a close watch to ensure everyone is working safely.

It's no surprise the shop is designed around a safety-first attitude, a consideration that extends to the machines Mehler has selected. The majority are by Felder, said Mehler, who feels they're not only extremely well built, but that the guard systems and dust collection capabilities make them "much, much safer" than many other woodworking machines. Mehler is concerned that because this is such high-end equipment his students aren't getting training on machinery they're likely to own, but feels the safety benefits outweigh that concern. "The people who come to my school are my responsibility; I feel more comfortable with people using machinery on which the safety features are as good as possible," he said.

Also, because many of his machines convert from one type of tool to another, they're more space-efficient than a series of dedicated machines. The Felder BF741 Combo machine that sits in the center of the first floor



Students are hard at work on drop-leaf tables on the shop's second floor. Here, they do handwork and use portable power tools. Like downstairs, all the equipment connects to dust collectors, and air filtration systems help students breathe cleaner air – another health/safety issue that Mehler is diligent about.

of Mehler's 30' x 40' shop is a jointer, mortiser, sliding table saw and shaper, all in one. He also has a Felder AD741 jointer/planer, a Felder KF700 sliding table saw/shaper and a Felder FD250 mortiser, as well as a Laguna 16" HD band saw, a 24" Mini Max band saw and an Oliver jointer, among other machines.

Off the back of the ground floor is a 16' x 16' shed full of lumber Mehler has acquired from a number of sources. Students can purchase from the shed, or supply their own stock.

Developing good wood sources and a keen eye for wood selection are lessons Mehler is eager to pass on to all his students, and it's something he's known for in his own work as well. "I've learned to seek out quality logs and have them sawn, then I keep the whole log and let it air dry," he said. When he builds a piece of furniture, he uses boards from the same log to achieve striking unity in the bookmatched tops, drawer fronts and even the interiors.

The second floor of the school is dedicated to workbenches, hand tools and a few small

machines. There's also a sink/sharpening station, and a separate office/lunch room/library, from which students can borrow books overnight. A 12' x 12' deck affords the opportunity to do handwork outside on balmy days.

And while Mehler is a table saw expert and has a large collection of power equipment, he stresses the importance of learning hand tool techniques as well. "It's often easier and more effective to use a hand tool than to set up a machine; you have to balance it out."

Mehler has achieved balance in his own life as well. Instead of creating custom pieces for others, he's finally outfitting his own house. Going to work in the morning means a stroll through the bucolic yard at the base of an Appalachian foothill. "It's a nice combination of loving my work, and working where I live," he said. "I am able to meet and work with wonderful people who come here eager to learn. I can't ask for more than that!"

For more information and to register, visit kellymehler.com or call 859-986-5540. **PW**



This 16' x 16' lumber shed is easily accessible from both inside and outside the ground floor of the shop.

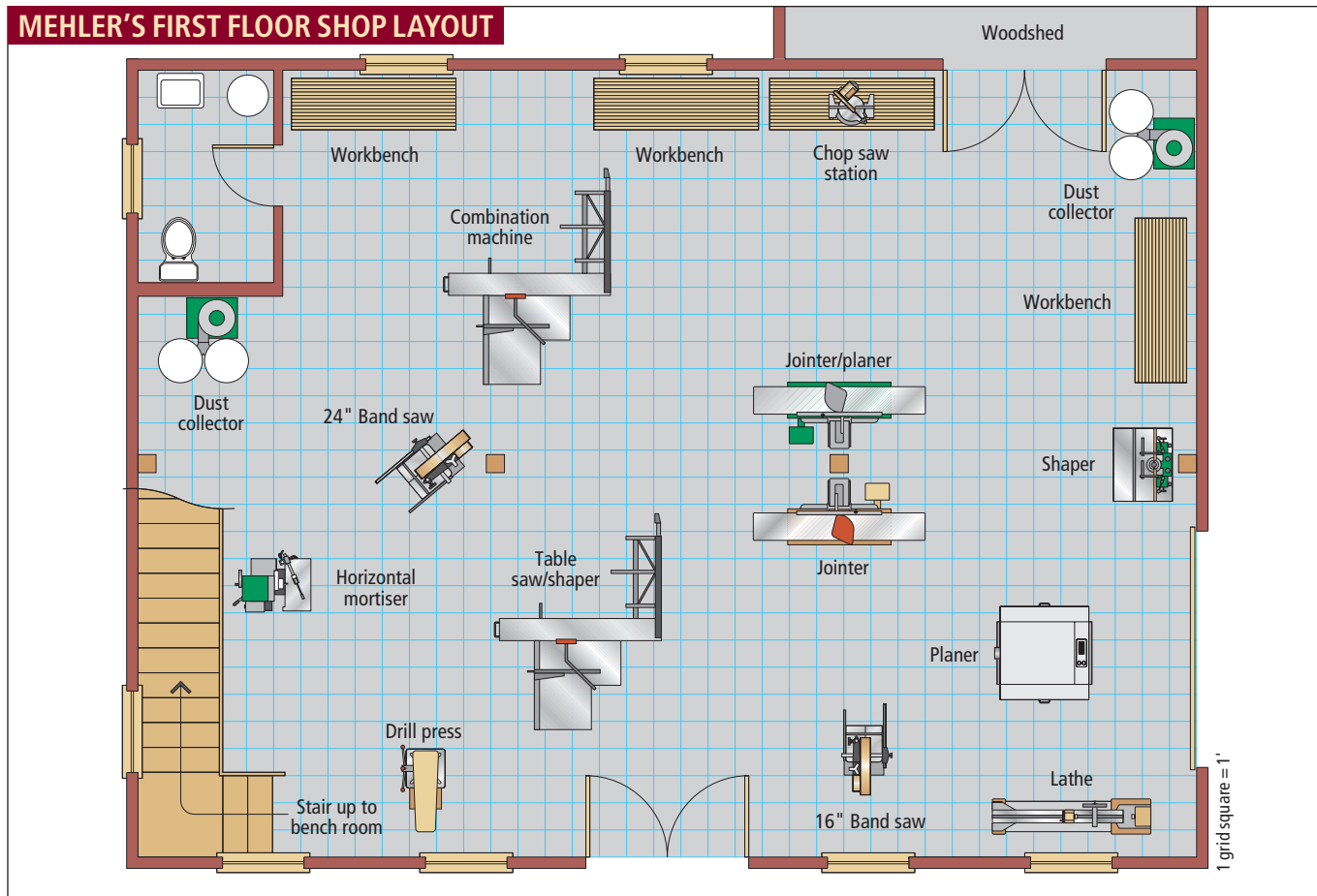

PRODUCT INDEX

	PAGE #	CIRCLE #	WEB ADDRESS		PAGE #	CIRCLE #	WEB ADDRESS
ADHESIVES				SAWMILLS & KILNS			
EpoxyHeads	8	114	epoxyheads.com	Granberg International	94	122	granberg.com
Gorilla Glue	31	121	gorillaglu.com	Norwood Industries	95	140	norwoodindustries.com
Liquid Nails	17	135	liquidnails.com	SCHOOL/INSTRUCTION			
Old Brown Glue	94	141	oldbrownglu.com	Center for Furniture Craftsmanship	11	109	woodschoo.org
BITS, BLADES & CUTTERS				SHOP ACCESSORIES			
Amana Tool	25	102	amanatool.com	Airware America	94	101	airwareamerica.com
CMT	18	110	cmtusa.com	EZ-Mount	17	115	ez-mount.com
Forrest	11	119	stores.yahoo.com/forrestman	Oneida Air Systems	15	142	oneida-air.com
Infinity Tools	20	126	infinitytools.com	TURNING SUPPLIES			
Routerbits.com	94	146	routerbits.com	Augums Pen Works	94	105	augumspenworks.com
Woodline USA	35	157	woodline.com	Packard Woodworks	94	143	packardwoodworks.com
FASTENERS				WOOD & VENEERS			
Arrow Fasteners	14	104	arrowfasteners.com	M.L. Condon	94	136	—
McFeely's	20	138	mcfelys.com	Wall Lumber	31	154	walllumber.com
FINISHES & SUPPLIES				Woodfinder	95	—	woodfinder.com
Critter Spray Systems	31	112	wwdc.com/critter	Woodworker's Source	94	161	woodworkerssource.com
FURNITURE & PROJECT PARTS				WOODWORKING CATALOGS			
Adams Wood Products	12	100	adamswoodproducts.com	Hartville Tool	12	125	hartvilletool.com
Architectual Products	94	103	archpro.com	Woodcraft	8, 15, 89	156, 168, 170	woodcraft.com
HAND TOOLS				Woodworker's Supply	31	162	woodworker.com
Blue Spruce Toolworks	94	106	bluesprucetoolworks.com	WOODWORKING SHOWS			
Bob's Rule	12	108	bobsrule.com	Woodworking Show, The	31	163	thewoodworkingshows.com
Fine Tool Journal	95	118	finetoolj.com				
Irwin	7	127	irwin.com				
Japan Woodworker	11	128	thejapanwoodworker.com				
Lee Valley	19	133	leevalley.com				
Lie-Nielsen Toolworks	89	134	lie-nielsen.com				
Robert Larson	19	145	rlarson.com				
Tools for Working Wood	89	151	toolsforworkingwood.com				
Traditional Woodworker	94	152	traditionalwoodworker.com				
HARDWARE							
Whitechapel Ltd.	24	155	whitechapel-ltd.com				
Woodworker's Hardware	19	160	wwhardware.com				
KITS & PLANS							
Craftsman Plans	95	—	craftsmanplans.com				
Glen-L Marine	95	120	glen-l.com				
Pygmy Boats	94	144	pygmyboats.com				
Texas Knifemaker	94	150	texasknife.com				
U-Bild.com	95	153	u-bild.com				
MISCELLANEOUS							
DR Power Equipment	25	—	drpower.com				
POWER TOOLS							
Bob Marino's Festool Store	17	107	festool.safeshopper.com				
Delta Machinery	4-5	113	deltamachinery.com				
Fein Power Tools	C3	116	feinus.com				
Festool	13	117	festool-usa.com				
GreX USA	11	123	gexusa.com				
Grizzly Industrial	C2-1	124	grizzly.com				
Jet	22-23	130	jettools.com				
Makita USA	C4	137	makitatools.com				
Porter-Cable	2	171	portercable.com				
Shopbot	15	148	shopbottools.com				
Smithy & Company	24	172	smithy.com				
Woodstock International	9	159	woodstockinternational.com				
POWER TOOL ACCESSORIES							
Craftsman Gallery	95	111	thecraftsmangallery.com				
JessEm Tools	19	129	jessem.com				
Keller & Company	20	131	kellerdovetail.com				
Kreg Tool	11	132	kregtool.com				
Leigh Industries	15	—	leighjigs.com				
Mystic Works	94	139	featherbow.com				
Saw-Jaw	94	147	saw-jaw.com				
Speed-Cope	24	149	speedcope.com				
Woodpeckers	14	158	woodpeck.com				

See something you want? Need more information?

Use the Free Information Card in this issue to receive free advertiser information.

For **faster service**, go **online** at www.popwood.com and click "FREE INFORMATION" or **fax the card** to 585-321-0043.

Win a Leigh D1600 Dovetail Jig!

When you request information, you're automatically entered in our drawing to win a Leigh Industries D1600 Dovetail Jig. This beautifully engineered jig handles 16"-wide boards and routs through dovetails up to 1³/₁₆" thick and half-blinds up to 1" thick – all with infinite adjustment of pin, tail width and spacing for that classic hand-cut look. Plus it does sliding dovetails. Dovetail joinery has never been easier. We'll select one lucky winner from the first 200 information requests received from this issue.



(See Advertiser Index or Product Index for circle numbers.)

ADVERTISER INDEX

ADVERTISER	PAGE #	CIRCLE #	WEB ADDRESS
Adams Wood Products	12	100	adamswoodproducts.com
Airware America	94	101	airwareamerica.com
Amana Tool	25	102	amanatool.com
Architectual Products	94	103	archpro.com
Arrow Fasteners	14	104	arrowfasteners.com
Augums Pen Works	94	105	augumspenworks.com
Blue Spruce Toolworks	94	106	bluesprucetoolworks.com
Bob Marino's Festool Store	17	107	festool.safeshopper.com
Bob's Rule	12	108	bobsrule.com
Center for Furniture Craftsmanship	11	109	woodschool.org
CMT	18	110	cmtusa.com
Craftsman Gallery	95	111	thecraftsmangallery.com
Craftsman Plans	95	—	craftsmanplans.com
Critter Spray Systems	31	112	wwdc.com/critter
DR Power Equipment	25	—	drpower.com
Delta Machinery	4-5	113	deltamachinery.com
EpoxyHeads	8	114	epoxyheads.com
EZ-Mount	17	115	ez-mount.com
Fein Power Tools	C3	116	feinus.com
Festool	13	117	festool-usa.com
Fine Tool Journal	95	118	finetoolj.com
Forrest	11	119	stores.yahoo.com/forrestman
Glen-L Marine	95	120	glen-l.com
Gorilla Glue	31	121	gorillaglu.com
Granberg International	94	122	granberg.com
Greg USA	11	123	gregusa.com
Grizzly Industrial	C2-1	124	grizzly.com
Hartville Tool	12	125	hartvilletool.com
Infinity Tools	20	126	infinitytools.com
Irwin	7	127	irwin.com
Japan Woodworker	11	128	thejapanwoodworker.com
JessEm Tools	19	129	jessem.com
Jet	22-23	130	jettools.com
Keller & Company	20	131	kellerdovetail.com
Kreg Tool	11	132	kregtool.com
Lee Valley	19	133	leevalley.com
Leigh Industries	15	—	leighjigs.com
Lie-Nielsen Toolworks	89	134	lie-nielsen.com
Liquid Nails	17	135	liquidnails.com
M.L. Condon	94	136	—
Makita USA	C4	137	makitools.com
McFeely's	20	138	mcfelys.com
Mystic Works	94	139	featherbow.com
Norwood Industries	95	140	norwoodindustries.com
Old Brown Glue	94	141	oldbrownglu.com
Oneida Air Systems	15	142	oneida-air.com
Packard Woodworks	94	143	packardwoodworks.com
Porter-Cable	2	171	portercable.com
Pygmy Boats	94	144	pygmyboats.com
Robert Larson	19	145	rlarson.com
Routerbits.com	94	146	routerbits.com
Saw-Jaw	94	147	saw-jaw.com
Shopbot	15	148	shopbottools.com
Smithy & Company	24	172	smithy.com
Speed-Cope	24	149	speedcope.com
Texas Knifemaker	94	150	texasknife.com
Tools for Working Wood	89	151	toolsforworkingwood.com
Traditional Woodworker	94	152	traditionalwoodworker.com
U-Bild.com	95	153	u-bild.com
Wall Lumber	31	154	walllumber.com
Whitechapel Ltd.	24	155	whitechapel-ltd.com
Woodcraft	8, 15, 89	156, 168, 170	woodcraft.com
Woodfinder	95	—	woodfinder.com
Woodline USA	35	157	woodline.com
Woodpeckers	14	158	woodpeck.com
Woodstock International	9	159	woodstockinternational.com
Woodworker's Hardware	19	160	wwhardware.com
Woodworker's Source	94	161	woodworkerssource.com
Woodworker's Supply	31	162	woodworker.com
Woodworking Show, The	31	163	thewoodworkingshows.com

We walk the talk.



Hand tools for the serious woodworker

800.426.4613 - 27 W. 20th St., #507 New York City



www.toolsforworkingwood.com

CIRCLE NO. 151 ON FREE INFORMATION CARD.

P. O. Box 9
Warren, ME 04864
800-327-2520

**Lie-Nielsen
TOOLWORKS®
INC.**

Medium Shoulder Plane

www.lie-nielsen.com

CIRCLE NO. 134 ON FREE INFORMATION CARD.



WOODCRAFT®
Helping You Make Wood Work®

For more information call 800 344-3348 or e-mail: bill_carroll@woodcraft.com

When woodworking is your passion, and owning your own business is your goal, Woodcraft can help you take your skill and expertise to the retail level.

**David & Aaron Sapp
Nashville, TN Franchise Owners**

"We're building a business that transcends generations. Having a Woodcraft franchise has helped us grow as a family while preparing our next generation for success."



Dept: F06PW06Q

RETAIL FRANCHISE OPPORTUNITIES • SUPPORT • TRAINING™

CIRCLE NO. 170 ON FREE INFORMATION CARD.

Understanding Stains

Don't let the dizzying array of choices get you discombobulated.

Go to any home center and you will probably be offered a choice of four types of stain: oil, varnish, water-based and gel (though the shelf arrangement and labeling of these stains rarely makes this clear).

Go instead to a paint store that caters to the professional painting and finishing trades and you will likely find lacquer stains and NGR (non-grain-raising) dye stains in addition to all or at least some of the stains available at home centers.

Shop at a woodworkers' store or from a catalog that caters to woodworkers, and to many of the stains already mentioned you can add water-soluble dyes and sometimes alcohol- and oil-soluble dyes.

Instead of buying any of these products to color wood, you could use "natural" stains such as the juice from walnut husks (boiled in water) or berries, or even coffee or tea. Or you could use a chemical such as lye, ammonia or potassium dichromate. (Natural stains fade rapidly; chemicals offer limited colors and are dangerous to use and difficult to control.)

You could also use a shading stain, toner or glaze to stain wood, though each of these is designed to be applied in between coats of finish. (I'm not going to discuss these products, or natural or chemical stains here.)

There are many types of stain. In this regard stains are like saws. (There are also many saws: table, band, jig, scroll, radial-arm, miter, sabre, hand, etc.) Each cuts wood just as all stains color wood.

But it is not likely you would use a table saw to cut a curve or a scroll saw to crosscut 8/4 oak. Each saw performs some cuts better than others; likewise, each type of stain handles and colors in its own unique way. To have full control of the coloring process,



Photos by the author

For most stains the best application method is to apply a wet coat of stain using a rag, brush, paint pad or spray gun and wipe off the excess before it dries. It's necessary to point this out because there are TV ads that show brushing stain and leaving it. This procedure leaves colored brush marks, usually obscures the wood, and often leads to the finish chipping or peeling.

you need to understand how stains differ and what each does best.

Oil Stain

Oil stains are the most widely available and are the type most people think of when they think of stain. These are the easiest to use because the linseed oil base or "binder" (sometimes a mixture of linseed oil and varnish) allows plenty of time to remove the excess before the stain dries – even on large projects.

You can identify oil stains by their thinning and clean-up solvent: mineral spirits (paint thinner). Most manufacturers list it as "petroleum distillate." Minwax uses the

more technical (and user unfriendly) name: "aliphatic hydrocarbon."

Unfortunately, oil stains are often referred to as "pigment stain" or "wiping stain" and this introduces confusion.

Though some oil stains contain only pigment, most contain pigment and dye, and many contain only dye. Moreover, many varnish, water-based, gel and lacquer stains contain only pigment, and these are rarely referred to as pigment stains.

Oil stains can be wiped, of course, but so can all stains – especially if the project is small. So technically, all stains can be wiping stains and the term loses its usefulness.

Choose an oil stain to apply under any finish except water based, and in all cases where you don't need any of the special characteristics offered by other stains.

by Bob Flexner

Bob is the author of "Understanding Wood Finishing" and a contributing editor to Popular Woodworking.

Varnish Stain

Varnish stains resemble oil stains in every way but one. Varnish stains use only varnish (sometimes polyurethane varnish) as the binder, so varnish stains dry hard while oil stains don't. Therefore, a varnish stain can be brushed on wood and left to dry without wiping whereas excess oil stain has to be wiped off or the finish applied on top may chip or peel.

Think of a varnish stain as alkyd paint with less colorant added.

Fortunately, most manufacturers label their varnish stains to distinguish them from oil stains because varnish stains use the same thinner as oil stains: mineral spirits. If you aren't sure whether a stain is varnish or oil, put a puddle of stain on top of the can or on another non-porous surface and see if it dries hard after several days in a warm room. Thick oil stains never harden.

Varnish stains are more difficult to use than oil stains because there is less time to wipe off the excess. Brushing and leaving the excess usually leaves prominent colored brush marks.

Traditionally, varnish stains were used most often to overcoat already stained and finished furniture, and woodwork that had become dull or scuffed. Because the stain hardens well, it didn't require a topcoat of finish in these situations and the brush marks were disguised by the already existing color.

Choose a varnish stain to overcoat an already stained and finished surface that is dull or scuffed, or if you're wiping off excess on a small project.

Water-based Stain

Water-based stains use water-based finish as the binder and replace most of the organic thinner with water. So these stains pollute less, are less irritating to be around and are easier to clean up than oil or varnish stains.

You can identify water-based stains by their thinning and clean-up solvent: water.

Water-based stains are usually best under water-based finishes because these finishes don't bond well over oil or varnish stains unless you give them a week or longer to thoroughly dry. Unfortunately, water-based stains are more difficult to use because they raise the grain of the wood and they dry fast.

Sanding off raised grain inevitably leads to

sanding through color in places. To avoid this, raise the grain and sand it off before applying the stain, or "bury" the raised grain.

To raise the grain first, wet the wood with a wet cloth. Let the wood dry overnight. Then sand off the roughness and apply the stain. To bury raised grain, simply apply the first coat of finish over the stain and raised grain, and then sand smooth.

Overcoming the quick drying time is more difficult. You can add a slow evaporating solvent (usually propylene glycol) provided by some manufacturers or you can add lacquer retarder. But adding either reduces the color intensity of the stain and defeats the purpose of using water-based products – to reduce exposure to solvents.

A better method is to divide your project into smaller parts and apply and wipe off the stain on each before going to the next. You can also have a second person follow you, quickly wiping off the excess.

PIGMENT AND DYE

Pigment and dye are the two primary colorants used in stains (chemicals being the other).

Pigment is ground earth or colored synthetic particles sized to imitate earth. The particles have weight so they settle to the bottom of the can if not kept in suspension by stirring.

Dye is a chemical that dissolves in one or more specific liquids (different dyes dissolve in different liquids). So dye becomes a part of the liquid and doesn't settle out.

You can tell if a stain contains pigment, dye or both by inserting a stirring stick after the stain has sat undisturbed on a shelf for several days or weeks. Pigment will have settled to the bottom; dye will still be in solution.

Because pigment has size it can't penetrate into wood. But after you wipe off excess stain, some pigment remains in pores and sanding scratches that are larger than the size of the pigment particles. This explains why sanding to finer grits produces a lighter coloring: less pigment can lodge.

Because dye dissolves in a liquid, it has no size and penetrates along with the liquid. So dye colors wood more uniformly.

You can't endlessly darken wood with pigment unless you leave some to build on

Choose a water-based stain for use under a water-based finish.

Gel Stain

Most gel stains are oil- or varnish-based, so they thin and clean up with mineral spirits. They are identifiable by their thickness, which is similar to mayonnaise. This makes them rather messy to apply, but gel stains solve the single biggest problem in wood finishing – blotching on pine.

Blotching is uneven coloring caused by varying densities in the wood and is the only problem that can't be fixed by stripping and starting over. The only way to remove blotching is to sand it out, which is very time consuming, or paint the wood, which is seldom a desired solution.

So gel stains serve a very important role in wood finishing. And they are much more predictable and easy to use (only one product to apply) than applying a wood conditioner

the surface (equivalent to painting). But dye can be applied in many coats to darken wood as much as you want without obscuring the wood or creating any build – as long as there is no binder in the dye that would itself build.

Dyes that don't build are NGR, water-soluble, alcohol-soluble and oil-soluble. Oil, varnish, water-based, gel and lacquer stains with dye included to add build.

All dyes, whether dissolved in solvent or containing an added binder, fade in bright light, especially sunlight and fluorescent light. You should avoid the use of dyes if your project will be placed in these conditions.

—BF



When excess stain is wiped off, pigment lodges in pores and sanding scratches highlighting them (left) while dye penetrates everywhere along with the liquid and colors more evenly.

before staining. (See “Wood Conditioner Confusion,” October 2005, issue #150, to understand why the directions on most brands don’t produce good results.)

Choose a gel stain when staining pine or similar soft woods.

Lacquer Stain

Lacquer stains use very fast-drying binders and solvents. Professional finishers often choose these types of stains because the finish can be applied within approximately 30 minutes, and the stain can be added to lacquer to make a “toner” for adjusting color between coats of finish.

You can identify lacquer stains by the strong, pungent odor caused by solvents such

as xylene and various ketones, which will be listed on the cans.

Lacquer stains are difficult to use because of their very fast drying. Professionals usually work in pairs, with one person spraying the stain and the other following right behind wiping off the excess.

Choose a lacquer stain if you are spraying and want to reduce the time between staining and finishing, or if you plan to add a colorant to your lacquer.

NGR Dye Stain

NGR stands for “non-grain-raising” and refers to a type of dye that’s usually dissolved in very fast evaporating solvents. As with lacquer stains, NGR dyes are favorites with profes-

sional finishers because there is little waiting between staining and finishing and the stain can be added to lacquer to make a toner.

All NGR dyes are packaged in liquid form and most contain methanol and sometimes other toxic solvents. No pigment or binder is included. Some NGR dyes are packaged in concentrated form and can be thinned with water, alcohol or lacquer thinner. (If thinned with water, they perform closer to the water-soluble dyes discussed below.)

Choose an NGR dye stain if you want a deeper or more even coloring than can be achieved with pigment. Also choose NGR if you want to reduce the time between staining and finishing or add a dye colorant to lacquer to make a toner.

CHOOSE THE RIGHT STAIN FOR THE JOB

TYPE OF STAIN	HOW TO IDENTIFY
Oil Stain	<ul style="list-style-type: none"> ■ Listed thinner and clean-up solvent is mineral spirits (“petroleum distillate,” “aliphatic hydrocarbon”)
Varnish Stain	<ul style="list-style-type: none"> ■ Listed thinner and clean-up solvent is mineral spirits (“petroleum distillate,” “aliphatic hydrocarbon”) ■ Labeled to indicate varnish, polyurethane varnish or hard-drying
Water-based Stain	<ul style="list-style-type: none"> ■ Listed thinner and clean-up solvent is water
Gel Stain	<ul style="list-style-type: none"> ■ Consistency is thick like mayonnaise
Lacquer Stain	<ul style="list-style-type: none"> ■ Strong odor ■ Xylene and/or ketones are listed as solvents
NGR (non-grain-raising) Dye Stain	<ul style="list-style-type: none"> ■ Dye packaged in liquid form ■ Usually contains methanol
Water-Soluble Dye Stain	<ul style="list-style-type: none"> ■ Dye packaged in powder form ■ Instructions are to dissolve in water

Water-, Alcohol- and Oil-soluble Dyes

These dyes are packaged in powder form, which makes them easy to identify. You have to dissolve them in the proper solvent.

Of the three, the most useful is water-soluble dye because it provides more time for wiping off the excess and there's no exposure to irritating solvents. (Handle grain raising and fast drying the same as with water-based stains, described earlier.) Alcohol-soluble dye is sometimes used by touch-up specialists precisely because of its very fast drying. Oil-soluble dye is rarely used anymore (except in oil stains). It's been replaced by NGR dye.

Choose a water-soluble dye if you want deeper or more even coloring than can be achieved with pigment. **PW**

COLOR INTENSITY

All types of stain can vary in color intensity depending on the ratio of colorant (pigment, dye or chemical) to liquid (oil, varnish, solvent, thinner, etc.). The higher the ratio of colorant to liquid, the darker the stain colors the wood. You can change the ratio in any stain by adding pigment, dye or thinner.

Sometimes you hear that you can make wood darker by leaving a stain on the surface longer before wiping off the excess. The explanation given is that the stain penetrates deeper. This is not true. What happens is that more thinner evaporates increasing the ratio of colorant to liquid. —BF



The color intensity of a stain is determined by the ratio of colorant to liquid. A full-strength commercial oil stain darkens wood more (left) than the same stain thinned 50 percent with mineral spirits (right).

MOST IMPORTANT PROPERTY

- Dries slowly so provides plenty of time to wipe off excess

- Dries hard so doesn't need a topcoat when coating over a stained and finished surface

- Reduces exposure to solvents

- Eliminates blotching on softwoods such as pine

- Dries very rapidly

- Colors more uniformly and intensely than pigment

- Colors more uniformly and intensely than pigment

WHEN TO USE

- Under any finish except water base
- You don't need a special property of another stain

- On small surfaces
- You want to leave excess to build
- When coating over an already stained and finished surface

- Under a water-based finish
- To avoid exposure to solvents
- You want easy water cleanup

- Staining pine or similar softwood

- For very fast drying
- To make a toner with lacquer

- For very fast drying
- For deeper and more even coloring than can be achieved with pigment
- To make a toner with lacquer

- For deeper and more even coloring than can be achieved with pigment
- To avoid exposure to solvents

COMMENT

- Allow overnight drying before coating over with a finish

- If wiping off excess, work rapidly or have a second person help

- If wiping off excess, work rapidly or have a second person help

- Compared to a liquid stain, gel stain reduces depth on many hardwoods

- You have to wipe off the excess within a minute or two, so it helps to work with a second person

- Spray the stain evenly and leave it, or work with a second person if wiping off excess

- Brushing a water-based finish over the dye may dissolve and smear it
- Apply a barrier coat of shellac or varnish (a "washcoat") in between

WOODWORKER'S MARKETPLACE

Texas Knifemaker's Supply

Make knives for fun and profit. We have all the supplies & kits for custom knifemaking.

*Easy transition from woodworking to knife making because you already have the tools

*Pre-made finished blanks ready to assemble

Free catalog

Call 888-461-8632 www.texasknife.com



CIRCLE NO. 150 ON FREE INFORMATION CARD.

HARDWOOD LUMBER

Lumber • Plywood • Burls
Turning Blocks • Veneers

Any length, any width, any thickness
Rough cut or milled to spec

256-pg Moulding Catalog \$40 + \$10 s&h

Call for a fast, free quote

M.L. GCONDON COMPANY Inc.

266 Ferris Avenue, White Plains, NY 10603
Phone: (914) 946-4111 • Fax: (914) 946-3779

FREE Lumber Catalog!



CIRCLE NO. 136 ON FREE INFORMATION CARD.

HARDWOODS
Lumber • Veneer • Turning Stock

Over 100 Quality Hardwoods
From Around the World

exoticwoods.net
Wood Descriptions • Prices • Current Specials
Secure On-Line Ordering

WOODWORKERS Source

5402 S. 40th Street • Phoenix, AZ 85040
800.423.2450



CIRCLE NO. 161 ON FREE INFORMATION CARD.

OLD BROWN GLUE

619-298-0864
OLDBROWNGLUE.COM



CIRCLE NO. 141 ON FREE INFORMATION CARD.

40,000+ Decorative Building Products

Widest Selection...
Lowest Prices...
All From Stock!

SHOP ONLINE!
FREE CATALOG!

www.archpro.com

Architectural Products by Outwater L.L.C.



CIRCLE NO. 103 ON FREE INFORMATION CARD.

Routerbits.com
Bits, Blades, Books, & More...

Whiteside Router Bits
Systematic Saw Blades Bench Dog
Fisch Forstner Bits
www.Routerbits.com

Call For Your Free Catalog
1-888-811-7269



CIRCLE NO. 146 ON FREE INFORMATION CARD.

Fine Bevel Edge Chisels
Made in Sweden

- Set of Eight with Leather Roll
- Ask for Model # 132-8000
- Sizes: 1/4", 3/8", 1/2", 5/8", 3/4", 7/8", 1", 1 1/4"

• Just \$139.95 for the Set
• Free Shipping (Lower 48 States)

Traditional Woodworker®
1-800-509-0081
www.traditionalwoodworker.com



CIRCLE NO. 152 ON FREE INFORMATION CARD.

Augum's Pen Works

The Largest Selection of Turning Kits and Woodworking Supplies Online!

Penn State Industries, Berea Hardwoods & More!
Pen, Keychain, Bottle Stopper Kits + Many More!

Everything You Need:
Tools, Adhesives, Finishing Supplies,
Gift & Display Boxes,
Inlay Supplies (Inlase, Crushed Stone),
Jewelry Supplies, Wood Blanks, Horn,
Corolpy, Diamondwood, Aquapearl + More!
All At The LOWEST PRICES On The Internet!
Number ONE In Customer Relations!
Come Give Us A Look!

www.AUGUMSPENWORKS.com

CIRCLE NO. 105 ON FREE INFORMATION CARD.

Trend Airshield
Includes Battery Charger

Airware America
20219 240th St., Elbow Lake, MN 56531
3M Authorized Distributor
e-mail: airware@runestone.net
www.airwareamerica.com

Free Info **1-800-328-1792**

Ideal for wood dust



CIRCLE NO. 101 ON FREE INFORMATION CARD.

Blue Spruce Toolworks

Beautiful hand tools for precision joinery

www.BLUESPRUCETOOLWORKS.com



CIRCLE NO. 106 ON FREE INFORMATION CARD.

Saw-Jaw

Order From Your Favorite Dealer • Online • Mail • Phone

Safely Install, Remove, Store & Protect
your costly 10" Circular Saw Blades

Saw-Jaw, PO Box 272 • Cedar Falls, Iowa 50613
www.saw-jaw.com • 1-800-SAW-9366



CIRCLE NO. 147 ON FREE INFORMATION CARD.

Top-Rated Sea Kayaks

Rugged, Ultra-Light Beautiful Leader in Kayak Kits Since 1986

PYGMY BOATS INC.

CALL OR WRITE FOR OUR FREE COLOR CATALOG
(360)385-6143, P.O. Box 1529, Dept 30
Port Townsend, WA 98368
www.pygmyboats.com



CIRCLE NO. 144 ON FREE INFORMATION CARD.

Get a Free Copy of our CATALOG for WOODTURNERS

Call Toll Free... **1-800-683-8876**

or write...
Packard Woodworks PO Box 718 Tryon, NC 28782
website: www.packardwoodworks.com

Packard WOODWORKS
"The Woodturner's Source"

CIRCLE NO. 143 ON FREE INFORMATION CARD.

STOP BUYING LUMBER!

Mill your own...
with Granberg's Alaskan Saw Mill!

Made in the U.S.A.

Prices start at **\$135!**
(G777 Small Log Mill)

Use our attachment and your chain saw to make beautiful lumber out of any log!
Call toll free for our FREE DVD and catalog!
866-233-6499 www.granberg.com



CIRCLE NO. 122 ON FREE INFORMATION CARD.

FEATHERBOW

FeatherBow 3 in 1
\$29.95

- Traditional featherboard
- Single feather
- Bow with 10LB and 35LB Gauge

Fits in standard 3/4" miter slot. Comes with 5 push sticks

FeatherBow Jr. 2 in 1
\$17.95

- Single feather for light work
- Bow that holds your work down

Made in USA Pat. Pending

860-209-5786 featherbow.com
137 TRESTLE DRIVE, VERNON, CT. 06066

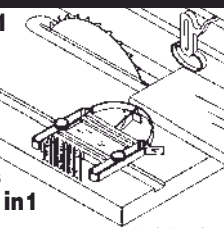

CIRCLE NO. 139 ON FREE INFORMATION CARD.

CRAFTSMAN PLANS



Authentic
Reproduction
PLANS
BOOKS
HARDWARE

Measured & Drawn by Robert W. Lang
author of
"Shop Drawings for Craftsman Furniture"
www.craftsmanplans.com

Need a precise and
affordable tool for
routing furniture joints?

Visit us...
we are the
WoodRat®
specialists!



www.chipsfly.com

CIRCLE NO. 111 ON FREE INFORMATION CARD.

U-BILD.COM

Hundreds of full-size woodworking plans at low prices. Free downloadable mini-plans. Indoor, outdoor, children's and holiday projects at all skill levels. 48-page catalog \$2.00 (refunded on 1st order) call (800) 828-2453.

CIRCLE NO. 153 ON FREE INFORMATION CARD.

NORWOOD
INDUSTRIES INC.
1-800-661-7746-Ext. 441
norwoodindustries.com

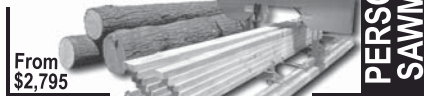

From
\$2,795

PERSONAL
SAWMILLS

CIRCLE NO. 140 ON FREE INFORMATION CARD.

Looking for wood?

VISIT
woodfinder



It's fast, easy and FREE!

www.woodfinder.com

No computer? Call toll-free 1-877-933-4637

Lie-Nielsen Standard or Low
Angle Block Plane.
Special \$135.00.

Fine Tool Journal
27 Fickett Rd.,
Pownal, ME 04069
(800) 248-8114



Always Free
US Shipping on

Lie-Nielsen Tools!

Full line
on web.
www.FineToolJ.com/LN

CIRCLE NO. 118 ON FREE INFORMATION CARD.



Build a
Boat &
Save!

Proven Plans & Kits make it simple to build your dream boat. Send \$9.95 today for huge catalog, refundable with order. Glen-L Marine, Box 1804/PW66, Bellflower, CA 90707 562-630-6258

www.Glen-L.com

CIRCLE NO. 120 ON FREE INFORMATION CARD.

STOP!

Before you buy your next tool, see how it performed
in *Popular Woodworking's* workshop!

Just log on to popularwoodworking.com. There you'll find out how dozens of tools performed in the *Popular Woodworking* shop. Plus, each review lists key features and important facts you need to know to make a smart and savvy tool purchase.

Check out this **FREE** service! **Log on today!**

www.popularwoodworking.com

CLASSIFIED

Classified rate is \$5.00 per word, 15-word minimum. Order must be accompanied by payment; ads are non-commissionable. Send to: Popular Woodworking, 4700 E. Galbraith Rd., Cincinnati, OH 45236 or Don Schroder, d.schroder@verizon.net. Phone: 610-821-4425, Fax: 610-821-7884.

BOOKS

WE HAVE A WIDE VARIETY of woodworking books – from small projects, to home improvement, to enhancing your woodworking skills, and more! To see our full line of books, please visit our web site at www.popularwoodworking.com/store/books/

BITS, BLADES & CUTTERS

PLANER KNIVES ANYONE CAN CHANGE at a price anyone can afford. Instant, accurate knife changes. Every machine, every time. German quality. Time-proven performance. Superior customer service. Dispoz-A-Blade.com. 800-557-8092.

BUSINESS OPPORTUNITIES

\$400 WEEKLY ASSEMBLING PRODUCTS from home. Rush SASE: Home Assembly - PW, Box 216, New Britain, CT 06050-0216.

FINISHING SUPPLIES & EQUIPMENT

SPRAY-ON SUEDE – Line boxes easily. Free brochure with sample. DonJer, 13142 Murphy Road, Winnebago, IL 61088; 800-336-6537; www.donjer.com

KITS & PLANS

CARLYLE LYNCH MEASURED DRAWINGS Museum and private collection furniture plans by Carlyle Lynch. Catalog \$2. PO Box 13007, Arlington, TX 76094; 817-861-1619.

HUNDREDS OF WOODCRAFT & SCROLLSAW PLANS Online WoodcraftPlans.com Catalog send \$1: 1329 Stanley, Dayton, Oh 45404

NEVER BEFORE IN REPRINT! Vintage Mission Furniture plans, Working Drawings, Mission Lamps, Copperworking, Art Metalwork. Gustav's Library www.gustavslibrary.com (877)520-9872

BRASS CANNON KITS 3 sizes to choose from. Check out The Big Dog now! umpire4men.com

POWER TOOLS

FEIN TOOLS - YOU'RE JUST ONE CLICK AWAY from the Fein Tools that you can't do without - MultiMaster Tools - Sanders - Routers - Grinder - Vacuums and more, plus all Accessories and Parts. <http://www.waltertool.com> or 800-356-6926.

SCHOOLS/INSTRUCTION

WOODWORKING COURSE Novice through intermediate, self-paced. Interactive CD-ROM based. Windows compatible. Only \$29.00. Order at www.fineboxes.com or 613-821-5160.

WOOD & VENEERS

WWW.WALNUTWOODS.NET Black Walnut Burl Veneer, lumber, turning stock, gunstocks. Buckeye Burl slabs. Call 559-277-8456, Newton Woods, Fresno, CA.

Woodworking Can be a Blast

Black powder fits the bill to split large urban logs.

For the past decade, I have been getting all the lumber I need for my projects from downed urban trees in my area that would have otherwise been dumped in local landfills, ground up for mulch or cut for firewood. I follow the same two-step procedure: First, as the tree is being prepared for removal, I make sure the trunk is cut to sawlog (not fireplace) lengths and, second, I then either haul the logs to the sawyer or tow the saw mill to the logs. After sawing, the boards are stickered and stacked for air-drying. However, last year for the first time ever, I inserted an extra and highly unusual step between cutting the log and sawing it into lumber.

Early in the year I got a call about a large bur oak that had been taken down in a nearby community. The owner was interested in whether I could convert the main trunk into lumber and then into several pieces of furniture. Without actually first seeing the log, I said that I probably could. Then I saw the log! It was about 12' in length, 10' in diameter at one end, and almost 6' at the other end. The large end consisted of multiple and converging limb stubs. A large telescoping crane had loaded the trunk, estimated to weigh 14,000 pounds, onto a tractor-trailer. It was hauled to the holding yard of a company that makes and sells mulch, the likely fate of this log if I could not find a way to reduce it to sizes my sawyer could handle. While theoretically the log could have been split lengthwise several times with a very large chain saw, as a practical matter this was not a feasible option. And because the professional tree service company that helped remove the tree was reluctant, I certainly wasn't going to try this approach either. I had no idea what to do and was close to telling the owner that this job was way too big for me.



Illustration by Pat Lewis

Then, by coincidence, I happened to find a man who likes to blow things up with black powder, including blowing up trees.

He inspected the log and said that he thought he could blow it lengthwise into several mill-sized sections, even though it would be the biggest one he had ever attempted. To increase the likelihood of success, the large end with the limb stubs was removed. Still, there was a distinct possibility that the powder would simply blow the log to smithereens.

On a rainy day in April 2005, the man and his assistant, several other witnesses, and I gathered to see if the log could be blasted into usable sections. I positioned myself about 50' away with the video camera ready to roll. The log was sitting on an

asphalt surface wet with rain. As the video at popularwoodworking.com shows, the first blast split the log into two halves and blew one across the slick asphalt in my general direction (click on "Magazine Extras" to see the movie). Fortunately, the angle of the blast was such that the log skidded past me instead of into me. Subsequent blasts (taped from a greater distance) parted the log into usable sections. My sawyer hauled them to his mill where they were sawed into lumber.

Today, most of the boards are air-drying in my shop where in a few months my son and I will begin fashioning them into the tables and benches the owner commissioned. My wife, who is a pen turner, turned 20 pens and 20 letter openers that the owner gave away as presents this past Christmas.

Final thoughts: If you have never worked with explosives, absolutely do not try this on your own. Regarding blasting anything, if you think you are far enough away, move back half again that distance anyway.

And, there is always another way to skin a cat, or split a log. **PW**

by Sam Sherrill

Sam is a professor at the University of Cincinnati. He is a lifelong woodworker and the author of "Harvesting Urban Timber: A Complete Guide" (2003, Linden Publishing). Contact him at samuel.sherrill@uc.edu or visit his web site at harvestingurbantimber.com.



As seen on TV!

The MULTIMASTER RS Kit One tool A few attachments Thousands of projects



Detail sand



Saw putty, wood, metal and fiberglass



Scrape paint



Remove grout

The new MULTIMASTER RS Remodeling/Renovation System.

Everything you need to make your house like new in one great kit. The MULTIMASTER does things other power tools can't. Sand into corners and along edges. Undercut a door jamb. Plunge into baseboard...right through the nails. Remove grout. Scrape paint.

The RS Kit contains a MULTIMASTER 636-2 variable speed tool plus:

- Sanding Pad
- HSS Segment Saw blade
- Scraper blade
- Carbide Rasp
- 20-pack assorted sandpaper, grits 60, 80, 120, 180
- Universal E-Cut blade
- Carbide Grout blade
- Tool wrench, screws and washers
- Plastic carrying case

For more information, a free brochure and to see the complete line of MULTIMASTERS and accessories at a dealer near you call **1-800-441-9878** or visit us on the web at www.feinus.com.



Plunge cut or undercut

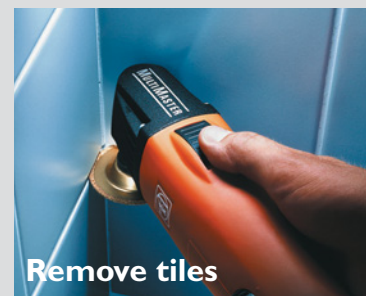

Remove tiles

Powered by innovation



CIRCLE NO. 116 ON FREE INFORMATION CARD.

18V POWER. 12V WEIGHT.™



LXT LITHIUM-ION



visit makitatools.com or call 1-800-4MAKITA



18V 4-Piece Combo Kit (LXT400)

FREE 18V LXT Recipro Saw by Mail with purchase of Combo Kit (LXT400)
Limited time offer, visit makitatools.com for details.

THE FUTURE OF CORDLESS IS NOW.

Makita's new LXT is Lithium-Ion Extreme Technology. The new Makita built, 4-pole maximum torque motor delivers more efficient power in a compact size. LXT is 40% lighter with an ergonomic shape that fits like a glove. The LXT Lithium-Ion Battery and Optimum Charging System produces 280% more lifetime work with 2X more cycles. The Optimum Charging System also controls the current with a CPU and built-in fan to maximize the overall battery life.

MORE WORK. LESS WEIGHT. BETTER ENGINEERING.™

Makita
INDUSTRIAL POWER TOOLS