

9 MYTHS OF FINISHING DEBUNKED – ONCE AND FOR ALL!

SPECIAL BONUS SECTION: COMPLETE GUIDE TO ROUTER TABLES

DECEMBER 2003  
ISSUE #138

# Popular Woodworking

## 24-HOUR SUPERBENCH

Inexpensive,  
Easy to Build,  
Stout as a Mule

Hey! Nice Legs

The Secret's  
In the End Grain

### PLUS

- Best Tools of 2003
- Gap-free Chessboard
- Golden Formulas for Great Furniture Designs

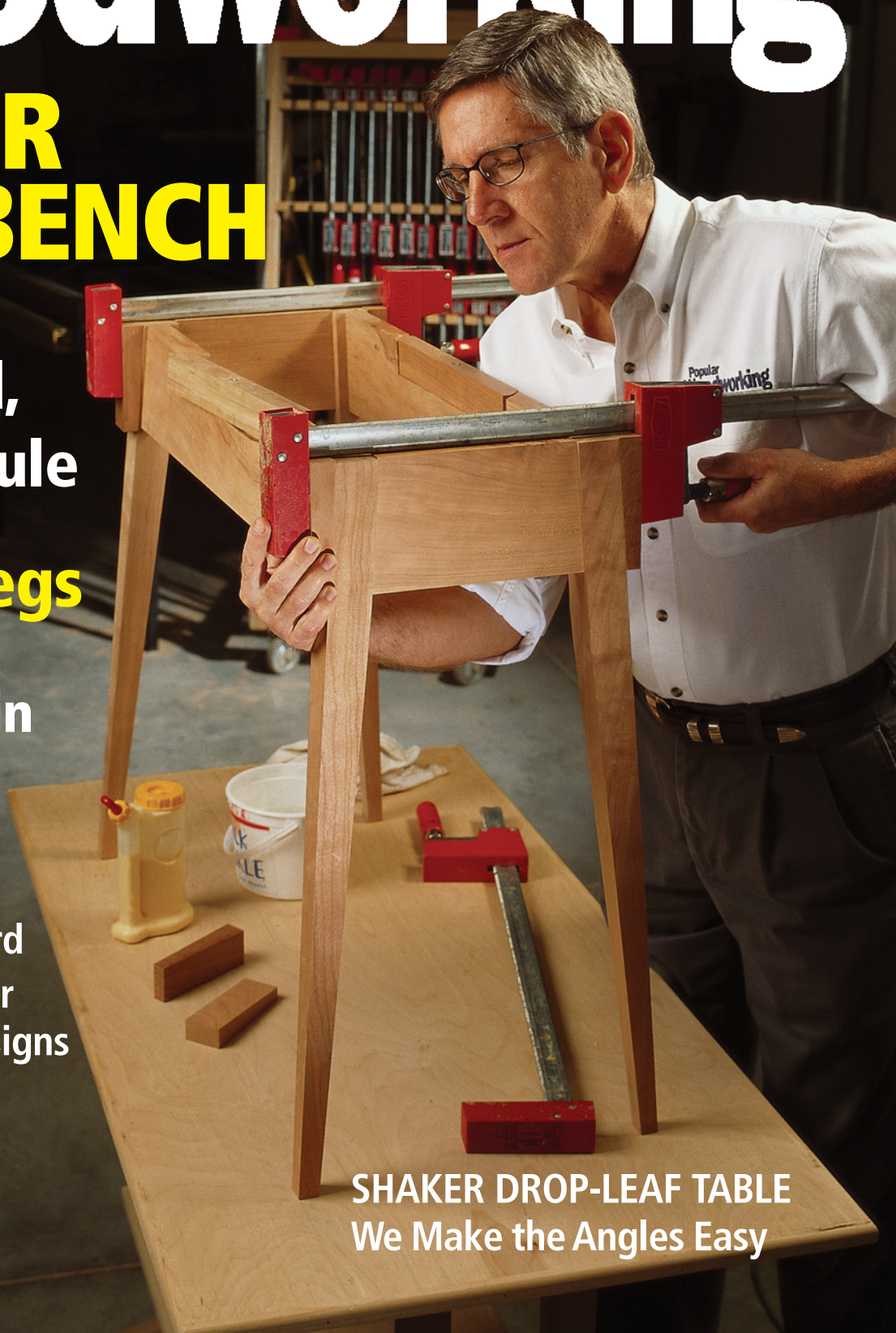

SHAKER DROP-LEAF TABLE  
We Make the Angles Easy

popwood.com  
\$4.99 U.S. \$7.99 CAN





# Grizzly Industrial

PURVEYORS OF FINE MACHINERY®

- OVER 830,000 SQUARE FEET PACKED TO THE RAFTERS WITH MACHINERY & TOOLS
- 2 OVERSEAS QUALITY CONTROL OFFICES STAFFED WITH QUALIFIED GRIZZLY ENGINEERS
- HUGE PARTS FACILITY WITH OVER 1 MILLION PARTS IN STOCK AT ALL TIMES
- TRAINED SERVICE TECHNICIANS AT EACH LOCATION • MOST ORDERS SHIPPED THE SAME DAY

**BUY DIRECT  
&  
SAVE!**

**CELEBRATING 20 YEARS OF SERVICE TO THE AMERICAN WORKSHOP!**

## 2 HP DUST COLLECTOR



- MOTOR SIZE: 2 HP, 220V, SINGLE-PHASE
- PORTABLE BASE SIZE: 21½" x 33½"
- STATIC PRESSURE: 12.3"
- AIR SUCTION CAPACITY: 1550 CFM
- STANDARD BAG FILTRATION: 30 MICRON
- MOTOR AMP DRAW: 12 AMPS (220V ONLY)
- APPROX. SHIPPING WEIGHT: 130 LBS.
- **FREE CYCLONE SEPARATOR WITH PURCHASE OF G1029**

G1029 ~~\$279<sup>95</sup>~~  
**ONLY \$249<sup>95</sup>**

## 12 SPEED 17" FLOOR DRILL PRESS

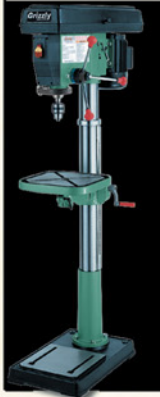

- MOTOR: 1 HP, SINGLE-PHASE, 110V/220V
- PRECISION GROUND CAST IRON TABLE
- TABLE SIZE: 13¾" SQUARE
- TABLE TILTS 90° IN BOTH DIRECTIONS
- SPINDLE TAPER: MT#3
- SPINDLE TRAVEL: 4¾"
- SWING: 17"
- DRILL CHUCK: ¾"
- 12 SPEEDS: 210 - 3300 RPM
- DRILLING CAPACITY: 1" STEEL
- INCLUDES BUILT-IN LIGHT
- OVERALL HEIGHT: 64½"
- APPROX. SHIPPING WEIGHT: 275 LBS.

**SPECIAL \$55<sup>00</sup>** REG. \$75<sup>00</sup>  
G7947 **ONLY \$375<sup>00</sup>**

## 10" TILTING ARBOR SUPER HEAVY-DUTY TABLE SAW



- MOTOR: 3 HP, 220V, SINGLE-PHASE
- PRECISION GROUND CAST IRON TABLE
- TABLE SIZE W/ WINGS ATTACHED: 36¼" x 27½"
- ARBOR DIAMETER: ¾" (ACCEPTS DADO BLADES UP TO 1¾")
- CUTTING CAPACITY: 8" LEFT & 25" RIGHT OF BLADE
- APPROX. SHIPPING WEIGHT: 360 LBS.

INCLUDES SHOP FOX® CLASSIC FENCE  
**SPECIAL \$55<sup>00</sup>** REG. \$75<sup>00</sup>  
G1023S ~~\$89<sup>50</sup>~~  
**SPECIAL \$825<sup>00</sup>**

## THE ULTIMATE 14" BANDSAW



- MOTOR: 1 HP, 110/220V, SINGLE-PHASE, TEFC
- PRECISION GROUND CAST IRON TABLE
- TABLE SIZE: 14" SQUARE
- TABLE TILT: 45° RIGHT, 10° LEFT
- FLOOR TO TABLE HEIGHT: 43¾"
- DELUXE EXTRUDED ALUMINUM FENCE
- CUTTING CAPACITY/THROAT: 13½"
- MAXIMUM CUTTING HEIGHT: 6"
- BLADE SIZE: 92½" - 93½" LONG (½" - ¾" WIDE)
- 2 BLADE SPEEDS: 1500 & 3200 FPM
- 4" DUST PORT
- APPROX. SHIPPING WEIGHT: 210 LBS.

**MADE IN ISO 9001 FACTORY**  
G0555 INTRODUCTORY PRICE  
**ONLY \$375<sup>00</sup>**

## 17" HEAVY-DUTY BANDSAW



- MOTOR: 2 HP, 110/220V, SINGLE-PHASE, TEFC
- PRECISION GROUND CAST IRON TABLE
- TABLE SIZE: 17" SQUARE
- TABLE TILT: 45° RIGHT, 10° LEFT
- FLOOR TO TABLE HEIGHT: 37½"
- CUTTING CAPACITY/THROAT: 16¼"
- MAXIMUM CUTTING HEIGHT: 12"
- DELUXE EXTRUDED ALUMINUM FENCE
- BLADE SIZE: 132" LONG (½" - 1" WIDE)
- 2 BLADE SPEEDS: 1600 & 3300 FPM
- TWO 4" DUST PORTS
- APPROX. SHIPPING WEIGHT: 321 LBS.

**CAST IRON FENCE & MITER GAUGE INCLUDED**  
**MADE IN ISO 9001 FACTORY**  
G0513 INTRODUCTORY PRICE  
**ONLY \$750<sup>00</sup>**

## 19" HEAVY-DUTY BANDSAW



- MOTOR: 2 HP, 110/220V, SINGLE-PHASE, TEFC
- PRECISION GROUND CAST IRON TABLE
- TABLE SIZE: 19" SQUARE
- CUTTING CAPACITY/THROAT: 18¼"
- MAX. CUTTING HEIGHT: 12"
- BLADE SIZE: 143" LONG (½" - 1¼" WIDE)
- 2 BLADE SPEEDS: 1700 & 3600 FPM
- TWO 4" DUST PORTS
- APPROX. SHIPPING WEIGHT: 383 LBS.

**FENCE & MITER GAUGE INCLUDED**  
**MADE IN ISO 9001 FACTORY**  
G0514 INTRODUCTORY PRICE  
**ONLY \$950<sup>00</sup>**

## 1½ HP SHAPER



- MOTOR: 1½ HP, 110/220V, SINGLE-PHASE
- PRECISION GROUND CAST IRON TABLE
- TABLE SIZE: 20¼" x 18"
- 2 INTERCHANGEABLE SPINDLES: ½" & ¾"
- SPINDLE TRAVEL: 3"
- SPINDLE OPENINGS: 1¼", 3½", & 5"
- 2 SPINDLE SPEEDS: 7000 & 10,000 RPM
- MAX. CUTTER DIAMETER: 5"
- APPROX. SHIPPING WEIGHT: 220 LBS.

**SPECIAL \$40<sup>00</sup>** REG. \$55<sup>00</sup>  
G1035 **ONLY \$425<sup>00</sup>**

**INCLUDES MITER GAUGE & FENCE**  
**SHOWN WITH OPTIONAL WING**  
G1706

## 3 HP SHAPER



- HEAVY-DUTY 3 HP, SINGLE-PHASE, 220V MOTOR W/REVERSING SWITCH
- PRECISION GROUND CAST IRON TABLE
- TABLE SIZE WITH STANDARD WING ATTACHED: 30½" x 28½"
- 3 INTERCHANGEABLE SPINDLES: ½", ¾" AND 1"
- SPINDLE TRAVEL: 3"
- 2 SPINDLE SPEEDS: 7,000 AND 10,000 RPM
- SPINDLE OPENINGS: 1½", 2¼", 4", AND 5½"
- FLOOR-TO-TABLE HEIGHT: 34"
- APPROX. SHIPPING WEIGHT: 353 LBS.

**INCLUDES MITER GAUGE & FENCE W/ HOLD-DOWN SPRINGS**  
G1026 ~~\$850<sup>00</sup>~~  
**ONLY \$825<sup>00</sup>**

**HOTTEST SHAPER IN THE USA!**

**SPECIAL \$55<sup>00</sup>** REG. \$75<sup>00</sup>

## POWER FEEDERS



- MOTOR: ½ HP, 220V, 4 AMP
- NUMBER OF SPEEDS: 4
- FEED SPEEDS: 9.5, 15, 25 & 38 FPM
- ROTATION: FORWARD & REVERSE
- ROLLERS: 3 SYNTHETIC RUBBER
- ROLLER SIZE: 2" W x 4" DIA.
- APPROX. SHIPPING WEIGHT: 115 LBS.

G4179 **ONLY \$599<sup>95</sup>**

**2 YEAR WARRANTY**

¼ HP POWER FEEDER  
**OUR MOST POPULAR FEEDER!**  
• MOTOR: ¼ HP, 110V, 1.8 AMP  
• NUMBER OF SPEEDS: 4  
• SPEED RANGE: 20, 26, 33 & 43 FPM  
• ROTATION: FORWARD & REVERSE  
• APPROX. SHIPPING WEIGHT: 80 LBS.  
G4176 **ONLY \$399<sup>95</sup>**

536403658  
MEDIA CODE  
AD1926



**1-800-523-4777**

CUSTOMER SERVICE: 570-546-9663  
CSR@GRIZZLY.COM  
FAX: 1-800-438-5901

# HOLIDAY SPECIALS

## OCTOBER 1st – DECEMBER 31st

**3 SHOWROOM LOCATIONS:**  
**MUNCY, PA • BELLINGHAM, WA • SPRINGFIELD, MO**



**Grizzly Gift Certificates**  
 ... the perfect solution to the "What do I get him?" dilemma.



### 6" X 47" JOINTER W/ HANDWHEELS

- MOTOR: 1 HP, 110/220V, SINGLE-PHASE
- PRECISION GROUND CAST IRON TABLE
- CUTTERHEAD: 3 HSS KNIVES
- MAXIMUM DEPTH OF CUT: 1/2"
- RABBETING CAPACITY: 1/2"
- HANDWHEELS FOR TABLE HEIGHT ADJUSTMENT

**TOOL BUYING GUIDE**  
 Editors' Choice

- BUILT IN CHIP CHUTE
- HEAVY-DUTY CENTER MOUNTED FENCE
- APPROX. SHIPPING WEIGHT: 215 LBS.



**FREE PAIR OF SAFETY PUSH BLOCKS**

**G1182HW**  
**ONLY \$325.00**  
**SPECIAL \$40.00 OFF**  
 REG. \$365.00 Shipping

### 8" X 65" SUPER HEAVY-DUTY JOINTER W/ HANDWHEELS

- MOTOR: 1 1/2 HP, 220V, SINGLE-PHASE
- PRECISION GROUND CAST IRON TABLE & FENCE
- CUTTERHEAD: 3 HSS KNIVES
- CUTTERHEAD DIAMETER: 3"
- MAXIMUM DEPTH OF CUT: 1/2"
- MAGNETIC SAFETY SWITCH

**TOOL BUYING GUIDE**  
 Editors' Choice

- INCLUDES JACK SCREWS & ACCESSORY SPRING KIT
- APPROX. SHIPPING WEIGHT: 450 LBS.



**FREE PAIR OF SAFETY PUSH BLOCKS**

**G1018HW**  
**ONLY \$695.00**  
**SPECIAL \$55.00 OFF**  
 REG. \$750.00 Shipping

### 8" X 75" JOINTER W/ 4 BLADE CUTTERHEAD

- MOTOR: 2 HP, 110/220V, SINGLE-PHASE, TEFC
- PRECISION GROUND CAST IRON TABLE
- TABLE SIZE: 8" X 75" INCLUDES TWO 5" EXTENSIONS
- CUTTERHEAD DIAMETER: 3"
- CUTTERHEAD SPEED: 5500 RPM
- MAXIMUM DEPTH OF CUT: 1/2"
- HEAVY-DUTY CENTER MOUNTED FENCE

**New!**

**FREE PAIR OF SAFETY PUSH BLOCKS**



**G0500**  
**INTRODUCTORY PRICE ONLY \$795.00**  
**SPECIAL \$55.00 OFF**  
 REG. \$850.00 Shipping

### 12 1/2" PORTABLE PLANER

- MOTOR: 2 HP, 110V, SINGLE-PHASE
- MAX. CUTTING WIDTH: 12 1/2"
- MAX. CUTTING DEPTH: 1/8"
- MAX. CUTTING HEIGHT: 6"
- MIN. BOARD THICKNESS: 3/16"
- 2 HSS KNIVES
- FEED RATE: 25 FPM
- ON/OFF TOGGLE SWITCH
- CUTTERHEAD SPEED: 8,540 RPM
- CUTS PER INCH: 57
- APPROX. SHIPPING WEIGHT: 85 LBS.

**WOOD WORKER'S CHOICE**  
**TOOL BUYING GUIDE**  
 Editors' Choice

**FREE 700 LB. CAPACITY STAND WITH PURCHASE OF G8794 PLANER**



**G8794**  
**ONLY \$299.95**  
**\$35 OFF**  
 REG. \$334.95 Shipping

### 15" PLANER

- MOTOR: 2 HP, 220V, SINGLE-PHASE
- PRECISION GROUND CAST IRON TABLE
- MAXIMUM CUTTING WIDTH: 14 7/8"
- MAXIMUM CUTTING HEIGHT: 6 1/8"
- MAXIMUM CUTTING DEPTH: 1/8"
- FEED RATE: 16 & 20 FPM
- NUMBER OF KNIVES: 3 HSS
- CUTTERHEAD SPEED: 5000 RPM
- MAGNETIC SWITCH W/ OVERLOAD PROTECTION
- APPROX. SHIPPING WEIGHT: 440 LBS.

**POPULAR READERS CHOICE AWARDS**  
**WOOD**

**STAND IS INCLUDED!**



**G1021**  
**ONLY \$795.00**  
**SPECIAL \$55.00 OFF**  
 REG. \$750.00 Shipping

### 20" PLANER

- MOTOR: 3 HP, 220V, SINGLE-PHASE
- PRECISION GROUND CAST IRON TABLE
- TABLE SIZE: 25 1/4" X 20"
- MAXIMUM CUTTING WIDTH: 20"
- MAXIMUM CUTTING HEIGHT: 8 3/8"
- MAXIMUM CUTTING DEPTH: 1/8"
- FEED RATE: 16 & 20 FPM
- NUMBER OF KNIVES: 4 HSS
- CUTTERHEAD SIZE: 3 1/4" DIAMETER
- CUTTERHEAD SPEED: 4833 RPM
- APPROX. SHIPPING WEIGHT: 785 LBS.

**WOOD WORKER'S CHOICE**  
**TOOL BUYING GUIDE**  
 Editors' Choice

**4 BLADE CUTTERHEAD!**



**G1033**  
**ONLY \$1295.00**  
**SPECIAL \$95.00 OFF**  
 REG. \$1500.00 Shipping

### OSCILLATING SPINDLE SANDER

- MOTOR: 1 HP, 110/220V, TEFC
- PRECISION GROUND CAST IRON TABLE
- TABLE SIZE: 25" X 25", TILTS TO 45°
- SPINDLE SIZES: 1/4" X 5", 3/8" X 6", 1/2" X 6", 5/8" X 6", 3/4" X 9", 1" X 9", 1 1/2" X 9", 2" X 9", 3" X 9", 4" X 9", TAPERED & THREADED
- SPINDLE OSCILLATION: 72 SPM
- STROKE LENGTH: 1 1/2"
- DUST PORT: 4"
- FEATURES GROUND STEEL TABLE INSERTS & 100 GRIT SLEEVE FOR EACH SPINDLE
- APPROX. SHIPPING WEIGHT: 301 LBS.

**INCLUDES 10 SPINDLE SIZES**

**WOOD WORKER'S CHOICE**  
**TOOL BUYING GUIDE**  
 Editors' Choice



**G1071**  
**ONLY \$525.00**  
**SPECIAL \$55.00 OFF**  
 REG. \$580.00 Shipping

### 24" DRUM SANDER W/ VARIABLE SPEED

- DRUM MOTOR: 5 HP, 220V
- SANDING DRUMS: 2 COMPUTER-BALANCED ALUMINUM
- CONVEYOR MOTOR: 1/4 HP, VARIABLE SPEED
- MAX. STOCK SIZE: 23 1/2" X 4 1/4" THICK
- HOOK & LOOP SANDPAPER
- CONTROL PANEL W/ AMP LOAD METER
- DUST PORTS: TWO 4"
- APPROX. SHIPPING WEIGHT: 495 LBS.

**Z-SERIES**

**VARIABLE SPEED!**



**G1066Z**  
**ONLY \$1595.00**  
**SPECIAL \$55.00 OFF**  
 REG. \$750.00 Shipping

### 15" WIDE-BELT SANDER (OPEN END)

- SANDING DRUM MOTOR: 5 HP, 220V, SINGLE-PHASE
- FEED BELT MOTOR: 1/4 HP
- CONVEYOR SPEED: 13 & 16.4 FPM
- AMP METER
- PNEUMATIC BELT TENSIONING & TRACKING
- DISC BRAKE FOR EMERGENCY STOPS
- INCLUDES EXTENDED SUPPORT BAR FOR WIDE BOARDS
- APPROX. SHIPPING WEIGHT: 922 LBS.



**G9983**  
**ONLY \$2795.00**  
**SPECIAL \$95.00 OFF**  
 REG. \$1500.00 Shipping

VISIT OUR WEBSITE  
 TO FIND MORE  
 HOLIDAY SPECIALS!

**grizzly.com**





# TWO GREAT BRANDS. ONE GREAT DEAL.



## Buy the best-selling **JET XACTA™ SAW** and get a **BOSCH Router FREE.**

Priced at just \$1,699, the 10" XACTA™ SAW, with a powerful 3HP motor, and packaged with the XACTA™ LIFT with a deluxe router fence, is a great deal. And now it's even better! Because if you buy this XACTA™ SAW package now, we'll upgrade your purchase to include our new Premier MicroAdjust Fence...that's a \$100 value!

But that's not all. You'll also get a Bosch Router...**absolutely free**. Valued at \$189, the Bosch 2 1/4 HP electronic, variable-speed router is the top choice. This complete package saves you a total of \$289! For more details, visit your local dealer, [www.jettools.com](http://www.jettools.com), [www.bosch.com](http://www.bosch.com) or call 1-800-274-6848.

# JET®

### IN EVERY ISSUE



## 19 Adjustable Outfeed Stand

### TRICKS OF THE TRADE

This easily made shop accessory can be used on uneven floors while staying parallel to the saw-table surface. Also: Install threaded inserts easier; better router-bit storage; mark lines on darker wood you can really see.

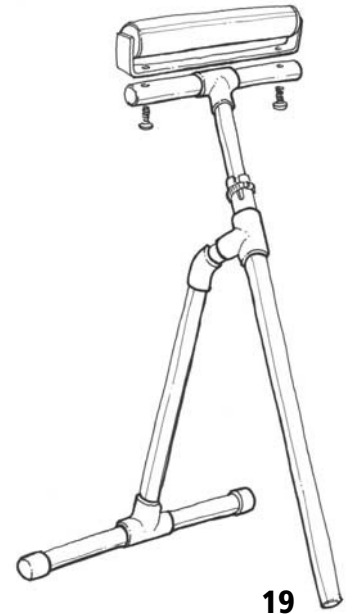

## 28 Frame Miter Joints

### POWER-TOOL JOINERY

The elegant miter joint can be difficult to cut and clamp. But fear not – help is here.

By Bill Hylton

## 32 Trend Airshield

### TOOL TEST

Turners can stay cool and breathe easier with this new face shield from Trend. Also: Ridgid's 5" random-orbit sander, E.C.E.'s Primus Smoothing Plane, Freud's shimless Dial-a-Width Dado Stack and a new doweling jig.



## 49 The Router Table

### WOODWORKING ESSENTIALS

Our seven-part series on routers continues with everything you need to know about operating your router in a router table. *Third of seven chapters.*

By Nick Engler

## 98 Traditional Wooden Planes

### FROM THE BENCH

Many people assume that wooden hand planes can't be as good as metal planes. Think again. One traditional woodworker argues that these tools are among the most elegant and functional ever made.

By Don McConnell

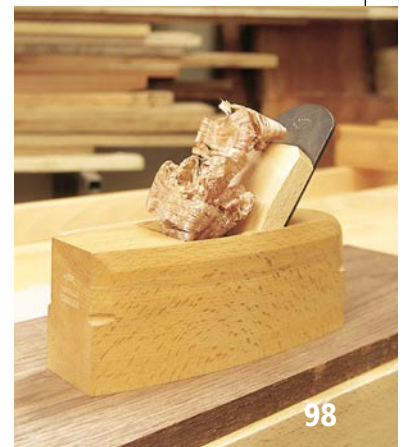

## 110 9 Myths of Finishing

### FLEXNER ON FINISHING

It's doubtful any craft has more myths associated with it than finishing. Our finishing expert sets the record straight, once and for all.

By Bob Flexner



Popular Woodworking (ISSN 0884-8823, USPS 752-250) is published seven times a year in February, April, June, August, October, November and December by F&W Publications Inc. Editorial and advertising offices are located at 4700 E. Galbraith Road, Cincinnati, Ohio 45236; tel.: 513-531-2222. Unsolicited manuscripts, photographs and artwork should include ample postage on a self-addressed, stamped envelope (SASE); otherwise they will not be returned. Subscription rates: A year's subscription (7 issues) is \$28; outside of U.S. add \$7/year • Canada Publications Mail Agreement No. 40025316. Canadian return address: 2744 Edna St., Windsor, ON N8Y 1V2 • Copyright © 2003 by Popular Woodworking. Periodicals postage paid at Cincinnati, Ohio, and additional mailing offices. Postmaster: Send all address changes to Popular Woodworking, P.O. Box 5369, Harlan, IA 51593 Canada GST Reg. # R122594716 • Produced and printed in the U.S.A.



42

## ON THE COVER

*The splayed legs of this classic drop-leaf table look tough to make and clamp correctly. But with a few tricks and common sense, this project is straightforward to build.*

Cover photo by Al Parrish

## DEPARTMENTS

**8** **Out on a Limb**  
*Checkbooks, Beer and Hand Planes*

**10** **Letters**  
*Mail from readers*

**15** **Q & A**  
*We answer readers' most difficult questions*

**112** **Out of the Woodwork**  
*Lessons From A Bird Feeder*  
*by Eric Johnson*

*Note: The Caption the Cartoon contest is on vacation this issue, but will return in February.*

## PROJECTS, TOOLS AND TECHNIQUES

### **36** 24-hour Workbench

Most woodworkers need a bench that is sturdy, versatile and economical. Look no further – we've developed the perfect one.

### **42** Cherry Shaker Drop-leaf Table

This unique splayed-leg table offers new challenges in angled tenons, plus you get an important lesson in rule joints.

### **46** Great-looking Legs

End grain is the key to making legs that look great from all angles.



36



66

### **66** Classic Chessboard

Nothing you build will be examined as closely as this game board. Here are the tricks to do it perfectly every time.

*By Barry Black*

### **72** The Golden Formulas

Learn simple rules that allow you to design furniture that pleases the eye. If you can add and multiply, you're halfway there.

*By Lonnie Bird*

### **76** Portable Chisel Rack

Keep your tools right where you need them with this handy shop accessory.

### **82** Music Cabinet

Simple joinery and common materials go a long way with this contemporary piece.

*By Chris Gleason*

### **89** Best New Tools of 2003

We've spent all year testing dozens and dozens of tools (poor us). Here's our list of the best 10.

### **94** Forbidden Forests

Some old-growth lumber still makes it to market. Is it better wood? Should you buy it? We visit an old-growth forest to find out.



82

**THEY'LL FIT YOUR BUDGET.  
YOUR CHIMNEY IS  
ANOTHER MATTER.**



**JET DELIVERS WHAT SANTA CAN'T:  
\$30 TO \$100 SAVINGS ON QUALITY TOOLS.\***

For a limited time, we're offering a holiday gift to remember: great savings on your choice of great tools.

From lathes and dust collectors to sanders and bandsaws,

JET tools have never been offered at such affordable prices. So get your list filled today. Take your pick of eight quality JET tools, each of which comes with a limited lifetime warranty.

You can be sure they'll fit your budget, even if they don't fit down your chimney.

For details, visit your JET distributor, [jettools.com](http://jettools.com) or call **800-274-6848**.



*\*Savings based on average retail prices.*



Only the JET Family of Brands offers you a Limited Lifetime Warranty on our most popular products.

**J E T**

Powermatic, Performax and JET.  
A Family of Brands.

CIRCLE NO. 123 ON FREE INFORMATION CARD.

# Router Bits and Shaper Cutters

# WOODLINE USA

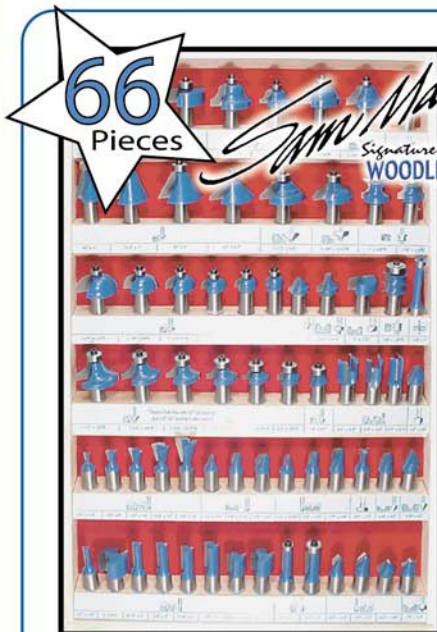

## Master Craftsman Woodworking Collection

Only \$189 set

- 8 Straight Bits
- 5 Dovetail Bits
- 3 Core Box Bits
- 3 Roundnose Bits
- 2 Flush Trim Bits
- 3 Mortising Bits
- 1 Plunging Panel Bit
- 1 Laminate Trim Bit
- 1 Bevel Bit
- 3 90° V-Groove Bits
- 2 Roman Ogee Bits
- 6 Roundover Bits
- 1 Point Cutting Roundover
- 1 Ogee With Fillet
- 1 Plunging Roundover W/ Bead
- 1 Double Roman Ogee W/ Cove
- 1 Plunging Roundover Stepped Cove
- 2 Edge Beading Bits
- 1 Multibeading Bit
- 1 Bowl & Tray Bit
- 1 Key Hole Bit
- 1 Double Roman Ogee
- 1 Classic Double Roundover
- 1 Flat Bottom 60 V-Groove
- 1 Standard 60 V-Groove
- 3 Rabbeting / Slot Cutters
- 4 Chamfer Bits
- 6 Cove Bits

WL 2066 For 1/2" Shank

WL 2065 For 1/4" Shank

## ANNOUNCING

Your Favorite Source For Router Bits And Shaper Cutters Has Teamed Up With Americas Favorite Master Craftsman To Bring You...

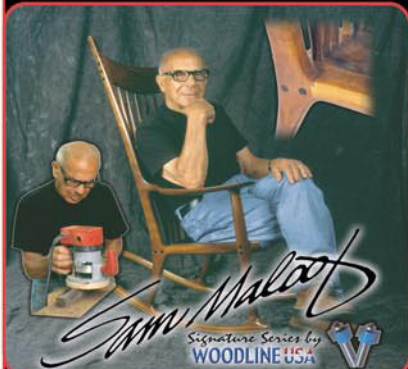

...A Premium Line Of Professional Tools From Our Workbench To Yours!

# WOODLINE USA

GREAT ROUTER BITS AND SHAPER CUTTERS  
BEST SELECTION / BEST PRICE!

ORDER TOLL FREE **1-800-472-6950**

WOODLINE USA • 111 WHEELER ST • LA VERGNE, TN 37086

Visit us at our Web site: **WOODBITS.COM**  
E-mail: woodline@woodbits.com

**PREMIUM CARBIDE**  
• Euro Anti-Kickback Design  
• Super-Slick Non-Stick Finish  
• Super Low Prices  
**QUALITY Guaranteed**



WL-2008 \$189 VALUE

OUR PRICE ONLY \$75 set

### PICTURE FRAME SET

8 Pcs

Perfect for making great looking picture frames. Bits can be combined to form complex mouldings or decorative frames.

### MOULDING SET

5 Incredible Profiles

OUR PRICE ONLY \$99 set

1/2" Shank Router Bits WL-2011 \$175 VALUE



### 3 Piece CABINET DOOR SET

1/2" Shank Router Bits  
2-pc Roman Ogee Rail & Stile  
3 1/4" Panel Raiser

WL-2019-1 \$129 VALUE

OUR PRICE ONLY \$69 set

Other Profiles Available



### MOUNTED LASER CUTTING GUIDE

Quality made. Precision cutting accuracy. Economical battery operated. (included) Versatile, easily mounts to your chop saw, compound miter saw, radial arm saw, or drill press.

Quality • Precise • Economical • Versatile



### 6 Piece CABINET DOOR SET

1/2" Shank Router Bits  
• 2-pc Rail & Stile (Roman Ogee) • Drawer Lock  
• 3 1/4" D Panel Raiser (Ogee) • Door Lip • Glue Joint

WL-2020-1 \$175 VALUE

OUR PRICE ONLY \$119 set

# Popular Woodworking®

December 2003, Vol. 23, No. 7

popwood.com

Editorial Offices 513-531-2690

Editor & Publisher **Steve Shanesy**  
ext. 1238 • steve.shanesy@fwpubs.com

Art Director **Linda Watts**  
ext. 1396 • linda.watts@fwpubs.com

Executive Editor **Christopher Schwarz**  
ext. 1407 • chris.schwarz@fwpubs.com

Senior Editor **David Thiel**  
ext. 1255 • david.thiel@fwpubs.com

Associate Editor **Kara Gebhart**  
ext. 1348 • kara.gebhart@fwpubs.com

Associate Editor **Michael A. Rabkin**  
ext. 1327 • michael.rabkin@fwpubs.com

Project Illustrator **John Hutchinson**

Photographer **Al Parrish**

Contributing Editors

**Nick Engler, Bob Flexner, Glen Huey, Don McConnell, Troy Sexton**

Magazine Group Head **David Hoguet**

Executive Vice President Magazine Advertising

**Jim Gleim**

### CIRCULATION

**Lynn Kruezkamp**, Group Circulation Manager

### PRODUCTION

**Barbara Schmitz**, Vice President  
**Vicki Whitford**, Production Supervisor

### ADVERTISING

**Don Schroder**, Advertising Director  
331 N. Arch St., Allentown, PA 18104  
Tel. 610-821-4425; Fax 610-821-7884  
d.schroder@verizon.net

Marketplace/Classified Advertising Sales

**Barbara J. Gasper**

6552 Kings Highway S., Zionsville, PA 18092  
Tel./Fax 610-967-1330  
bjgasper@entermail.net

Advertising Production Coordinator

**Debbie Thomas**, Tel. 513-531-2690 ext. 1219  
debbie.thomas@fwpubs.com

**SUBSCRIPTION SERVICES:** Subscription inquiries, orders and address changes can be made at popwood.com (click on "Subscriber Services"). Or by mail: Popular Woodworking, P.O. Box 5369, Harlan, IA 51593. Or call 800-888-6880 or 515-280-1721. Include your address with all inquiries.

Allow 6 to 8 weeks for delivery.

**NEWSSTAND DISTRIBUTION:** Curtis Circulation Co., 730 River Rd., New Milford, NJ 07646

### ATTENTION RETAILERS:

To carry Popular Woodworking in your store, call Steve Hudziak at 800-894-4656 or write Magazine Retail Sales, Steve Hudziak, P.O. Box 5014, Iola, WI 54945-5014.

Back issues are available for \$7 (\$9 Canada; \$11 other foreign). Send check or money order to: Popular Woodworking Back Issues, F&W Publications Products, 700 E. State St., Iola, WI 54990. Or call 800-258-0929. Please specify publication, month and year.

### SAFETY NOTE:

Safety is your responsibility. Manufacturers place safety devices on their equipment for a reason. In many photos you see in Popular Woodworking, these have been removed to provide clarity. In some cases we'll use an awkward body position so you can better see what's being demonstrated. Don't copy us. Think about each procedure you're going to perform beforehand. Safety First!

• INDIVIDUAL BITS ALSO AVAILABLE • ALL MAJOR CREDIT CARDS • SAME DAY SHIPPING •



# Cold, hard cash

**\$50 or \$100?**  
It's your choice.

Buy one of the qualifying products and we'll reimburse you \$100 on the purchase of a second JET®, Powermatic®, or Performax® machine (with net purchase price of \$349 or more) OR up to \$50 on the purchase of JET branded accessories. Pick up your second machine or accessories immediately — or until April 30, 2004.

Look for the green tags on the industry's hottest sellers at participating dealers. Cold, hard cash. It's an easy choice.



Look for these qualifying products:



Stock No. 629004K  
**\$799\***



Stock No. 710002  
**\$599\***  
Available November 1, 2003



Stock No. 1791210  
**\$1499\***



Stock No. 1791279K  
**\$749\***



Stock No. 1791216K  
**\$849\***



Stock No. 1791220K  
starting at **\$649\***



Stock No. 708528  
Stock No. 708584  
**\$1399\***



Stock No. 708775K  
starting at **\$849\***



Stock No. 708639 **\$299\***  
Stock No. 708626CK **\$449\***



Stock No. 354169  
**\$399\***



Stock No. 708115K **\$499\***  
Stock No. 710115K **\$599\***



Stock No. 708457K  
**\$549\***



Stock No. 708301K  
starting at **\$599\***



Stock No. 708531  
**\$899\***  
Available November 1, 2003



Stock No. 708750B  
**\$1099\***

\*Price shown is Manufacturer Suggested Retail Price. Offer valid September 1, 2003 through April 30, 2004. For promotion details, visit your dealer, see our website at [www.jettools.com](http://www.jettools.com), or call 1-800-274-6848.



**Now with Lifetime Warranty!**

As expected from the industry innovator, only the JET Family of Brands offers you a Limited Lifetime Warranty on many of our most popular products.

**J E T**

Powermatic, Performax and JET  
A Family Of Brands

# Checkbooks, Beer & Hand Planes

I'm always amazed by a misconception among woodworkers about hand tools. It goes something like this: Because power tools have replaced hand tools in many woodshops, power tools must therefore be more precise and clearly superior.

Nothing could be more wrong.

Really excellent work (tight joints, shimmering surfaces, perfectly fitted doors and crisp edges) are all far easier for me to achieve with hand tools than with a catalog full of jigs, doodads and, yes, power tools.

I first became aware of this noble truth 10 years ago when fitting the bottom into a blanket chest during a woodworking class. I needed to notch the corners of the large bottom piece so it would fit in the groove in the sides of the chest. I had devised an ingenious setup. It involved – no lie – a large torsion-box fence attached to the table saw's miter gauge, an accessory fence attached to the rip fence and a dado stack. It took me about two hours to set it all up.

As I was about to make the cuts, my instructor walked over to the table saw, took my bottom piece to his bench and cut the notches with a backsaw in two minutes. He handed the bottom back to me and my view of the world was changed.

So now when I want to fit a door or drawer in its opening, I use a jack plane to sneak

up on the perfect size in .001" increments if I so desire. I never overshoot.

When I want a mortise-and-tenon joint to have an airtight fit, I reach for a shoulder plane to trim the cheeks and shoulders.

And when I want a surface to look like a reflective pool of water, I use a smoothing plane, which slices open the wood's cells instead of scratching them into submission.

I could go on and on.

Of course, this bliss comes at a price. You've got to learn to sharpen – the most important woodworking skill I've ever picked up. Want a primer? Go to our web site and click on "Magazine Extras." You'll find the article "Sharpening Plane Irons & Chisels" there that will get you started.

And in case you think I'm a nutjob, consider this: I'll never give up my table saw, jointer or planer. In fact, I'm bewildered by people who use hand tools exclusively. For me, there's no joy in dressing lumber by hand.

So when stocking your shop with hand and power tools, remember this: It's just like beer, your checkbook and dancing – finding a good balance is best. **PW**

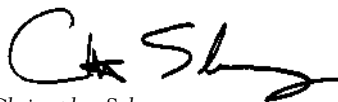

Christopher Schwarz  
Executive Editor

## Come Visit our Booth at the WoodWorks 2003 Shows this Fall and Winter

We're on tour with the WoodWorks shows right now and you can check us out at various stops in November and January. Come by our booth, hunt for great deals on subscriptions and woodworking books and sign up to win a tremendous prize!

What makes WoodWorks events special (in addition to the great deals on tools) are the



free demonstrations by the country's top woodworkers (such as Frank Klausz, left). Also, many exhibitors actively demonstrate the newest products right in their booth. You can't help but learn a lot and have a good time. Visit [woodworks2003.com](http://woodworks2003.com) for a

complete rundown on the shows, dates and free demonstrations. See you there!

## CONTRIBUTORS

### BARRY BLACK

When Barry Black was 5, he built a wooden box. "The box wasn't bad," he says, but when he nailed the lid on he knew he would have to learn something about hinges. Black grew up helping his father build cabinets in England. After 18 years in the



oil industry, he decided his career was interfering with his hobby – woodworking – so he quit and started Black Board Creations ([blackboardcreations.com](http://blackboardcreations.com)) in Alberta, Canada, with

his wife, Kari-Lynn. Today he thoroughly understands the concept of hinges. His boxes, such as the chessboard on page 66, are functional and beautiful. Black specializes in custom furniture, including Sam Maloof-style chairs. Also an antique tools dealer, Black's favorite tools are his Stanley No. 98 and No. 99 side-rabbit planes.

### DON MCCONNELL

Though Don McConnell has worked with his share of machinery (in one shop he was the only one allowed to adjust the jointer and planer), his true passion is for traditional hand tools. In 1977 he took an apprenticeship with Tom Clark in the cabinet shop at The Ohio



Village – a living history site similar to Colonial Williamsburg in Virginia – where he learned to create fine work without the assistance of electrons.

Since then he has worked professionally, building furniture, repairing antiques, constructing architectural elements and producing carved curved custom handrails mostly by hand. McConnell's biggest passion (outside of raising his teenage daughter) is for wooden-bodied planes, a topic he discusses in his column on page 98.

### Our Privacy Promise to You

We make portions of our customer list available to carefully screened companies that offer products and services we believe you may enjoy. If you do not want to receive offers and/or information, please let us know by contacting us at:

List Manager, F & W Publications,  
4700 E. Galbraith Road, Cincinnati, OH 45236

# GRIPPING BREAKTHROUGH



## MULTI-GRIP™ HOLDING SYSTEM

- STRONG** RIGID CROSS BEAMS FOR MAXIMUM CLAMPING PRESSURE
- PORTABLE** ATTACH TO ANY SURFACE UP TO 2-1/2 INCHES THICK
- DURABLE** HIGH IMPACT, REINFORCED COMPOSITE RESIN

LIFETIME WARRANTY



VISE

BAR CLAMP

FREE STANDING

SPREADER

WORKSTATION

JOIN THE GRIPPING REVOLUTION!

To find MULTI-GRIP at a store near you, just call 1-800-519-7381 or visit [www.wiltonmultigrip.com](http://www.wiltonmultigrip.com).



CIRCLE NO. 125 ON FREE INFORMATION CARD.



**WOODCRAFT®**  
UNIVERSITY

**T**here's a  
**Woodcraft University**  
location near you

**Alabama**

Birmingham Area

**Arizona**

Tempe  
Tucson

**California**

Sacramento  
San Francisco Bay Area  
Santa Rosa

**Colorado**

Colorado Springs  
Denver

**Connecticut**

Hartford Area  
New Haven Area

**Florida**

Casselberry  
Clearwater  
Jacksonville

**Georgia**

Atlanta Area

**Hawaii**

Honolulu

**Idaho**

Boise

**Illinois**

Palatine  
Peoria

**Indiana**

Evansville  
Indianapolis

**Iowa**

West Des Moines

**Kansas**

Lenexa

**Kentucky**

Louisville

**Maryland**

Towson

**Massachusetts**

Woburn

**Michigan**

Canton  
Sterling Heights

**Minnesota**

Bloomington

**Missouri**

St. Louis Area

**New Hampshire**

Portsmouth Area

**New Mexico**

Albuquerque

**New York**

Rochester

**North Carolina**

Charlotte Area  
Raleigh

**Ohio**

Cincinnati Area  
Cleveland Area  
Columbus Area  
Dayton

**Oklahoma**

Oklahoma City  
Tulsa

**Oregon**

Eugene  
Portland Area

**Pennsylvania**

Harrisburg  
Philadelphia Area  
Pittsburgh Area

**Rhode Island**

East Greenwich

**South Carolina**

Charleston

**Tennessee**

Knoxville  
Nashville

**Texas**

Austin  
Dallas Area  
Fort Worth  
Houston  
San Antonio

**Utah**

Salt Lake City Area

**Virginia**

Richmond  
Washington D.C. Area

**Washington**

Seattle

**West Virginia**

Parkersburg

**Wisconsin**

Appleton/Fox Cities Area  
Madison  
Milwaukee Area

**Woodworker's Club:**

**Connecticut**

Norwalk

**Maryland**

Rockville

LETTERS

# Another Hand-saw Answer: Cut it Off

## One Sailor's Father Found His Own Answer to the Hand-saw Debate

Re: "Japanese Saws vs. Western Saws" (October 2003): As a young sailor in Japan in 1950, I mailed my family some small gifts. For my father, I picked a beautiful traditional ryoba hand saw, as he did a little woodworking now and then. I recall the saw cost me 200 yen (about 60 cents).

I returned home a couple of years later and asked my father how he liked the saw. His reply was, "Some idiot put the handle on the wrong end" and he told me he cut the handle off and riveted it back on the other end. My father Westernized an Eastern saw.

I never used the saw, and I don't think it would work very well. I retired from the Navy in 1966 and now have a small home workshop. Mostly I make sawdust, new curse words and mistakes. I take in several woodworking magazines and yours is the best. But I am sick of tool reviews – I want projects and ideas and new ways to make sawdust.

J.H. Wheeler  
Hialeah, Florida

## Do I Really Need to Upgrade my Chipbreakers for New Planes?

I enjoyed your review of the Lie-Nielsen chipbreakers (Tool Test, October 2003) and have a question: I recently purchased a Lie-Nielsen No. 5 and a Lie-Nielsen No. 4½ (both new before the upgraded chipbreaker was available but with A2 cryogenic irons). Would there be a measurable improvement to either plane with an upgraded chipbreaker?

Ed Wald  
Bensalem, Pennsylvania

*Editor's Note: I purchased both sizes of chipbreakers from Lie-Nielsen. They really make a difference when you're dealing with the high-tolerance planing involved with a smoother, such as your No. 4½. It's overkill on a jack plane unless you are using it for fine finishing cuts like*

*a smoothing plane (which I do sometimes). If I had to buy only one size, I'd get the one for your No. 4½. But I bet that once you see how nice it is, you'll want one for your No. 5, too.*

– Christopher Schwarz, executive editor

## What Happens to the Waste Pieces When You're Cutting Miters?

In "10 Tricks for Tight Joints" (October 2003), Jim Stack says that when cutting a miter, the waste is between the 45° sawblade and the fence. Wouldn't this pinch, burn or send a "chunk" at the person doing the cutting?

Bob Walters  
Portland, Oregon

*Editor's Note: Jim's method works really well. I've used it myself for years and am astonished how easy it makes cutting miters. On to your question: Yes, the waste is between the blade and fence. While we often hear this is a no-no, it's not a big deal with this operation for two reasons. First, because the workpiece is so long, the waste piece likely won't get thrown back at you – it weighs too much. Second, if it does come at you, it shouldn't hit you if you are standing where you should be (out of the line of the blade).*

continued on page 12

## WRITE TO US

Popular Woodworking welcomes letters from readers with comments about the magazine or woodworking in general. We try to respond to all correspondence. Published letters may be edited for length or style. All letters become the property of Popular Woodworking. How to send your letter:

- E-mail: [popwood@fwpubs.com](mailto:popwood@fwpubs.com)
- Fax: 513-891-7196
- Mail carrier:  
Letters • Popular Woodworking  
4700 E. Galbraith Road  
Cincinnati, OH 45236

**WOODCRAFT®**

For your local woodcraft store, visit [www.woodcraft.com](http://www.woodcraft.com), or for a free catalog, call 800 542-9115

Dept.03PW12BE

*what can take your passion and turn it into perfection?*



**WOODCRAFT**<sup>®</sup>  
UNIVERSITY

**T**here's nothing better than hands-on learning with a highly skilled mentor to really enhance your woodworking craft. For years, Woodcraft has brought you the finest class instruction, woodworking books, and videos - now we're introducing the most complete woodworking tool of all - Woodcraft University.

Each of the University Colleges - Turning, Carving, Sharpening, Joinery, Router, Power Tools, and Finishing can help turn your woodworking passion into perfection. No matter what your skill level, in Woodcraft University classes, you'll learn turning with master turners, sharpening with experts, power tool techniques from recognized artisans, and much more.

Start with 100 Level Turning Classes - Beginning Lathe, Turning A Classic Pen, or Making Wooden Spoons, then move up to intermediate or advanced skill level classes. Woodcraft University offers you more opportunities to learn in classes certified for continuing education credit.

Your local Woodcraft store or Woodworkers Club has all the class schedules and details to get you started in woodworking education from Woodcraft University.

Experience the finest in woodworking tools, power tools, and education from our catalog, online at [www.woodcraft.com](http://www.woodcraft.com), and at your local Woodcraft store.



**WOODCRAFT**<sup>®</sup>  
Helping You Make Wood Work<sup>®</sup>

CIRCLE NO. 157 ON FREE INFORMATION CARD.

# STEVE WALL LUMBER CO.

Quality Hardwoods and Woodworking machinery For The Craftsman and Educational Institutions

**\*NOW AVAILABLE\***  
**Custom Made Raised Panel Cabinet Doors**

4/4 Log Run Walnut 100 bd. ft. \$160 Also Available Exotic Lumber

Ash	4/4	Select	2.40	\$ 85.00
Basswood	4/4	Select	1.95	\$ 72.00
Birch	4/4	Select	2.75	\$ 89.00
Butternut	4/4	1C	2.30	\$ 77.00
Cherry	4/4	Select	4.90	\$110.00
Hickory - Pecan	4/4	Select	2.85	\$ 89.00
Mahogany (Genuine)	4/4	Select	3.90	\$100.00
Maple (Hard)	4/4	Select	3.15	\$ 96.00
Maple (Soft)	4/4	Select	2.30	\$ 79.00
Poplar	4/4	Select	1.75	\$ 72.00
Red Oak	4/4	Select	2.50	\$ 88.00
Walnut	4/4	Select	4.00	\$100.00
White Oak	4/4	Select	2.50	\$ 88.00
Cedar (Aromatic Red)	4/4	1C+Btr.	1.80	\$ 72.00
Cypress	4/4	Select	2.40	\$ 80.00
White Pine	4/4	F.G.	1.20	\$ 62.00
Yellow Pine	4/4	Clear	2.00	\$ 74.00

**UPS  
Specials**

**SEE OUR  
CATALOG ON  
THE WEB!**

**STEVE H. WALL  
LUMBER CO.**

BOX 287  
 MAYODAN, N.C. 27027  
 336-427-0637  
 1-800-633-4062  
 FAX 336-427-7588

Email: wood@walllumber.com  
 Website: www.walllumber.com

Send \$1.00 For Lumber Catalog  
 Prices Subject to Change Without Notice

Above prices are for 100 quantities of kilndried rough lumber sold by the Bd. Ft. FOB Mayodan, NC. Call for quantity discounts. Other sizes and grades available.

Above prices are 20 bd. ft. bundles of clear kilndried lumber 3'-10" wide 3-7' long (Random widths & lengths) Surfaced 2 sides or rough. Delivered UPS prepaid in the Continental U.S.

CIRCLE NO. 152 ON FREE INFORMATION CARD.

## LETTERS

continued from page 10

As to burning, that is usually more of a problem when the work is caught between the fence and blade. This technique actually makes the joint very easy to cut.

— Christopher Schwarz, executive editor

### Reader Appreciates Tool Reports

I read the response from the disgruntled reader about how you review and report on tools (Letters, October 2003). He's certainly entitled to his opinion and I believe you gave him a diplomatic response. But understand that I have subscribed to virtually every woodworking magazine on the market and *Popular Woodworking* offers the most comprehensive, thorough, well-written tool reports and reviews of any of the magazines. It is my contention that *Popular Woodworking* makes a point to look for the great values in tools and to offer its readers great alternatives to the premium tools whenever possible. You guys just do a fantastic job. Keep up the good work.

Kevin Bradley  
 Battle Creek, Michigan

### Hooked on Shaker Oval Boxes

As a graduate of John Wilson's Shaker Box class, I thoroughly enjoyed "Building Shaker Oval Boxes" in the August 2003 issue. Having produced boxes at his shop (twice) and on my own, I found the article really covers it.

I've described him to my fellow woodworkers as a sort of drug dealer. He lets you sample merchandise for next-to-nothing, gets you hooked and then keeps you supplied for life. He even sells the paraphernalia! Thanks again for the great article. **PW**

Mark Thompson  
 Fort Wayne, Indiana

### CORRECTION

*Popular Woodworking* corrects all significant errors. For a list of corrections to the magazine, or to report one, please visit our web site at popwood.com and click on "Magazine Extras."

• In "12 Best Tool Values" (October 2003) the phone number for Grizzly Industrial, maker of the G10235 Cabinet Saw pictured here, was incorrect. The number is 800-523-4777.



INTRODUCING

## SHIM-FREE SLOT CUTTER

If you can turn the knob on a radio, you can adjust Amana Tool's® new:

# EZ DIAL™ SLOT CUTTER

- ✓ Finally, a slot cutter with nothing to lose. No shims, no spacers.
- ✓ Nothing to take apart, just dial it, lock it, cut it.
- ✓ Easily makes perfect grooves for today's undersized plywood.
- ✓ Perfect for edge ("T") molding installation.
- ✓ Available in two sizes:
  - #55500 For 1/8"-1/4" wide slots, 1/2" deep
  - #55510 For 1/4"-1/2" wide slots, 1/2" deep
- ✓ Carbide tipped for long life.



**Special Introductory Price** **\$99<sup>95</sup>** ea.

List Price \$149<sup>95</sup> ea.



**Amana Tool®**  
 High Performance Cutting Tools

For Our New Catalog or a Dealer Nearest You  
**CALL 1-800-445-0077**  
 Visit our website at  
[www.amanatool.com](http://www.amanatool.com)

CIRCLE NO. 102 ON FREE INFORMATION CARD.

# More power. More torque. More jealousy on the job site.



[www.ridgid.com](http://www.ridgid.com)

Introducing a whole new line of over 30 professional-grade power tools from RIDGID® that'll seriously outperform what you're using now. These tools are packed with the features you want. Like Exactline™ laser precision. Motors that last up to five times longer. A dual-port battery charger that gets you to full power in half the time. And the best warranty in the business. Need we say more?

**RIDGID**

Powerful. Durable. Professional.



Available at The Home Depot.®

CIRCLE NO. 145 ON FREE INFORMATION CARD.

**MEASURE. SQUARE. MEASURE. CUT.**

*Or get a Biesemeyer fence and just cut.*

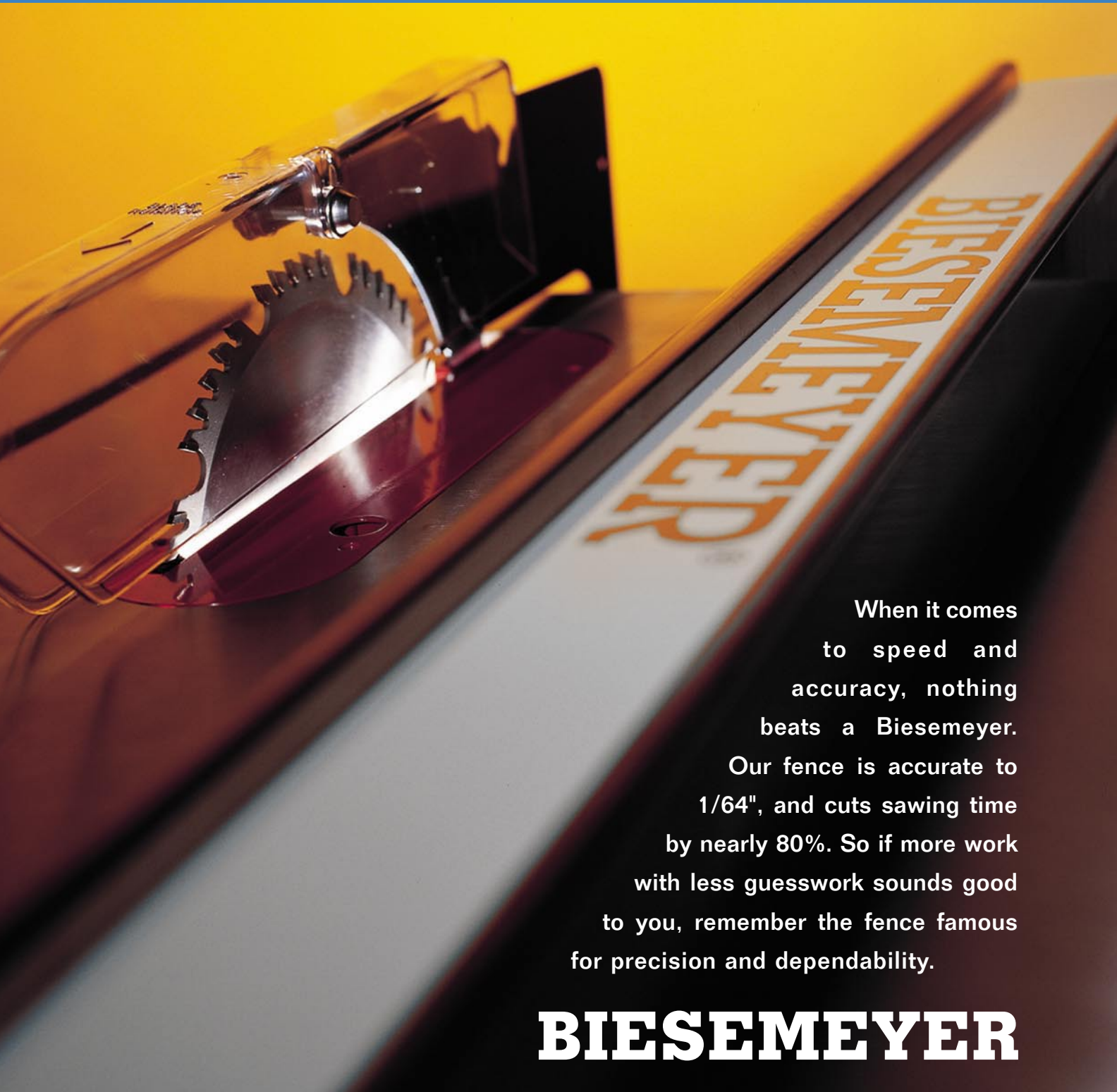

When it comes to speed and accuracy, nothing beats a Biesemeyer. Our fence is accurate to 1/64", and cuts sawing time by nearly 80%. So if more work with less guesswork sounds good to you, remember the fence famous for precision and dependability.

**BIESEMEYER**

WWW.BIESEMEYER.COM • 1.800.782.1831

CIRCLE NO. 107 ON FREE INFORMATION CARD.



# Tape Measures Will Wiggle for a Reason

## The Hook on Your Tape Measure Moves to Ensure Accuracy

After reading "The 16 Dumbest Woodworking Mistakes" (August 2003), I offer a suggestion that has made things a little easier for me when dealing with measurements that are a bit off.

Like your article stated, I found that the tab on the end of the tape measure can become loose and slide  $\frac{1}{32}$ " to as much as  $\frac{1}{16}$ ". After trying numerous times to tighten the rivets that secure the tab to the tape (either by squeezing them with pliers or pounding them with a hammer), I came upon a simple solution.

While holding the tape measure's end tab at the correct position for a true first-inch measurement, I super-glued the tab in position, making sure there was ample glue around and under the tab. This simple trick has taken away a lot of frustration from those cuts that were just a  $\frac{1}{16}$ " off.

Larry Weisman  
via the Internet

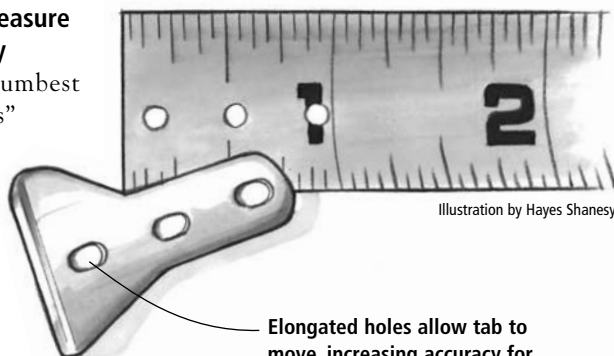

Illustration by Hayes Shanesy

Elongated holes allow tab to move, increasing accuracy for inside measurements

The "slop" in the tape-rule tab actually serves a purpose: It allows you to take both inside and outside measurements with the same rule. When you're measuring the inside of a cabinet, you're pressing the tab against the cabinet side, causing the tab to slide against the end of the tape. In this case, the distance from the outside face of the tab to the 1" mark should be exactly 1" (if your tape rule is accurate).

Conversely, when you're taking an outside measurement, you hook the tab over the edge of the workpiece instead, pulling the tab outward. Then the distance from the inside face of the tab to the 1" mark should be exactly 1". On an accurate tape rule, the amount of "slop" in the tab should equal the thickness of the tab.

— Paul Anthony

Popular Woodworking contributor

## My Drill Press is Powerless

I like to build clocks for family members, and I rely fairly heavily on the quartz inserts found in many catalogs. I had been using my router with a template and a  $\frac{1}{4}$ " straight bit with a bushing to cut the hole for the inserts, but a while back I bought one of the 3" saw-tooth drill bits to do the job instead.

The bit works fine in softwoods, but it bogs down instantly in hardwood (particu-

continued on page 17

The Delta Edge  
Get a \$50 rebate  
on cutting edge  
miter saws.



NEW

### 36-412, 12" Dual Bevel, Front Bevel Lock Compound Miter Saw

Mega Capacity, Ultimate Trim Saw

- World's largest 12" capacity.
- Cuts a 2 x 10 in one cut.
- Cuts a 4 x 6 in one cut.
- Cuts  $9\frac{1}{8}$ " base and  $8\frac{1}{4}$ " crown.
- Innovative Front Bevel Lock and detents mean no more reaching behind the saw.
- Flip-up crown molding stops and patented easy-squeeze dual sliding fences.



NEW

### 36-312, 12" Front Bevel Lock Compound Miter Saw

The Durable Saw You Can  
Take From Site To Site

- Innovative Front Bevel Lock and detents mean no more reaching behind the saw.
- Lightweight, compact and durable.
- Easy to carry from job to job.
- Cuts  $7\frac{1}{4}$ " base and  $6\frac{1}{2}$ " crown.

For your nearest dealer, visit  
deltamachinery.com/rebate.  
Rebate valid 11/1/03 through 2/15/04.

**DELTA**

Your achievement. Our tools.

## WRITE TO US

Every day we get questions from readers on all subjects about their woodworking. Some are letters; many are e-mail messages. We are more than happy to share our woodworking experience with you by answering your questions or adding some clarity to whatever aspect of your craft you are unsure about. In addition to the hundreds we answer privately every month, we want to share the best questions here with readers.

Send us your questions or concerns via e-mail to [popwood@fwpubs.com](mailto:popwood@fwpubs.com), or send us a note by regular mail to *Popular Woodworking*, Q&A, 4700 E. Galbraith Road, Cincinnati, OH 45236.



**CUT. GLOAT. REPEAT.**

**INTRODUCING OUR TWINLASER MITER SAW**

For precision and speed, nothing can touch our new TwinLaser™ Compound Miter Saw. Because the TwinLaser™ system shows the exact line of cut on either side of the blade kerf, at any angle, with or without the blade in motion. It's even bright enough for outdoor use. You might have even seen it on New Yankee Workshop with Norm Abram. Call 800-438-2486 (US), 800-463-3582 (Canada) or visit [deltamachinery.com](http://deltamachinery.com) for a free catalog.

*TWINLASER*

**DELTA**

Your achievement. Our tools.

CIRCLE NO. 165 ON FREE INFORMATION CARD.

continued from page 15

larly maple, my favorite). I have a Delta ¾-horsepower drill press (converted to 240-volt service) and I'm surprised it doesn't have the "oomph" to drive that bit. Am I expecting too much from a bit that size, or should my press be able to drive that bit at its slowest speed (215 rpm) regardless of wood? By the way, the bit is high-speed steel and is sharp.

Greg Long  
Corvallis, Oregon

My guess is that your machine should indeed have the power to make that cut. You might want to check a couple of things on the machine (if you haven't already): First, make sure your belts are snug. They shouldn't deflect more than ¼" under pressure from your finger. Second, check the nuts on top of the step pulleys. These can loosen and cause the exact problem you are describing. Tighten them up with a wrench. Third, if you ever do need to squeeze more power out of a machine, replace the V-belts with Powertwist link belts (available almost everywhere for about \$5 a foot). These transmit power more efficiently and are less likely to slip.

— Christopher Schwarz, executive editor

### Should I be Concerned About Microbevels on my Block Plane?

When sharpening the iron for a low-angle block plane (where the bevel always faces upwards), the angle of that bevel directly affects the angle of the cut against the wood. Wouldn't putting a microbevel on the iron increase the angle, thereby defeating one of the purposes of a low-angle plane?

I've never seen this question addressed in articles on planes and sharpening.

Bill Law  
Cincinnati, Ohio

You are correct: A microbevel will change the cutting geometry of a bevel-up plane, such as a block plane. But usually a microbevel is just a degree or two, so it shouldn't change things radically. If you are experiencing problems that you think are related to the cutting geometry (i.e., more tear-out than you expect) you might want to first see what your actual cutting angle is. If it's too high, regrind your iron and start over with a fresh edge.

You might want to think about trying a 23° or 24° primary bevel (as opposed to the standard 25°). Then your microbevel will take you

back to factory-perfect. Another solution is to dispense with the microbevel altogether and hone the entire primary bevel. Block planes are small suckers, so this isn't too onerous.

Finally, don't be afraid to experiment with different angles on your block plane. Some woodworkers grind the bevel at 20°. This angle is great for trimming end grain, but the edge is more likely to fail prematurely. Let your work and your patience for sharpening be your guide.

— Christopher Schwarz, executive editor

### How Should I Finish a Redwood Deck?

We are constructing a nice-sized redwood deck on our log home in Arizona. Our dilemma is how to finish it.

I have seen stains that others have put on their redwood decks that leave a surface layer that splits and cracks after a short time in the direct Arizona sun and heat. I am considering boiled linseed oil as a treatment for the redwood. I don't care for the oil/varnish mixtures because they, too, leave a surface layer. Given my direct sunlight and heat situation, what do you recommend?

Ray Pfeiffer  
Seligman, Arizona

Linseed oil attracts mildew in some of the damper climates. I don't know if there's enough moisture where you live for this to be a big problem. But the linseed oil will be wiped out by the sun very quickly. It will just disappear, so I don't recommend you use it.

The way I see it, you have two choices. If you don't mind the wood turning gray, just leave it bare. The surface will gray (I'm sure you see this gray color on wood all the time in Arizona), but the wood will hold up great. Redwood does not split nearly as much as pressure-treated pine.

If you want to keep the redwood color, the only way to do this is to stain the wood with a redwood-colored stain and reapply it whenever the color begins to wear off. This is the only way that I know of because no clear finish, oil or anything else will prevent the wood from graying from the ultraviolet light.

Just use any deck stain you can find at a nearby home center. Water-based stains have a tendency to build, so they are more likely to crack than oil-based stains, which soak in better. I'd use an oil-based stain, meaning one that thins with paint thinner. **PW**

— Bob Flexner, contributing editor

## The Delta Edge These miter saws even cut you a \$50 rebate.



36-255L, 12" **TWINLASER™**  
Compound Miter Saw

Accurate, Fast, Heavy Duty

- The world's first TwinLaser™ system makes this the fastest, most accurate saw available.
- Great for precise bevel and compound cuts.
- The same saw Norm uses.



MS450, 12" **ShopMaster™**  
Compound Miter Saw

An Unbelievable Value

- Built for power (15 amps) - yet affordably priced
- Low price includes full features like fences, clamps and extensions

For your nearest dealer, visit  
deltamachinery.com/rebate.  
Rebate valid 11/1/03 through 2/15/04.

**DELTA**

Your achievement. Our tools.

Call for our **NEW**  
Product & Specification  
Catalog



## For All Your Cabinet Needs...

We have the largest selection  
of cabinet hardware  
in the industry.  
**Over 8000 items  
in stock.**

[www.wwhardware.com](http://www.wwhardware.com)

**Woodworker's Hardware**

PO Box 180 Sauk Rapids, MN 56379

**800-383-0130**

Mention offer #385



CIRCLE NO. 162 ON FREE INFORMATION CARD.

**NEW!**

## The Leigh FMT Mortise and Tenon Jig

Create mortises and tenons in one quick, easy setup!

Unique patented guide system • Joints from a tiny 1/16" x 3/32" to 1/2" x 5" in stock up to 3" x 5 1/2" • Easy fingertip adjustment of joint tightness, recordable and repeatable • Make angled and compound angled joints • Rout perfectly aligned double, triple and quadruple joints • Use virtually any plunge router • Uses 1/2" shank cutters • Cam-action speed-clamps • Integral dust port for vacuum



Call For Your Free Leigh FMT Brochure Today! 1-800-663-8932  
Leigh Industries Ltd., PO Box 357, Port Coquitlam, BC, Canada V3C 4K6  
Tel. 604 464-2700 Fax 604 464-7404 Web [www.leighjigs.com](http://www.leighjigs.com)

**LEIGH**  
Joining Tradition With Today



For those who get all excited over the prospect of selection, we offer a delicious assortment of hardware with something for every taste. And this is only a sampler of knobs. Our 200-page, full-color catalog has an equally enticing assortment of complete suites, pulls, handles, locks, hinges, slides, and more. Call to request a free hardware catalog or visit us online.

1-800-683-8170 [www.leevalley.com](http://www.leevalley.com)

**Lee Valley**

Lee Valley Tools Ltd.  
814 Proctor Avenue  
Ogdensburg, N.Y. 13669

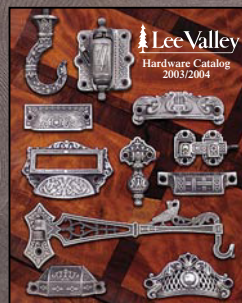

CIRCLE NO. 129 ON FREE INFORMATION CARD.

**FREE PROJECT PLANS**

[www.popularwoodworking.com](http://www.popularwoodworking.com)

**FREE PROJECT PLANS**

[www.popularwoodworking.com](http://www.popularwoodworking.com)

**FREE PROJECT PLANS**

[www.popularwoodworking.com](http://www.popularwoodworking.com)

**FREE PROJECT PLANS**

**GENERAL** **GENERAL INTERNATIONAL** **PRECISION WOODWORKING TOOLS**

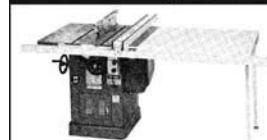

**EXCEPTIONAL PRICING SERVICE & VALUE**  
Made In Canada

**GENERAL MACHINERY**

The only High Quality, Heavy Duty Line of Woodworking Equipment  
Tablesaws, Jointers, Mortisers, Lathes, Drill Presses and accessories including Modulus® Scoring Saw Attachment



[www.woodworktools.com](http://www.woodworktools.com)  
**ASHMAN TECHNICAL LTD.**

351 Nash Rd, N. Hamilton, Ontario, CANADA L8H 7P4  
Phone 905-560-2400 • FAX: 905-560-2404

**1-800-668-5721**

CIRCLE NO. 104 ON FREE INFORMATION CARD.

# Adjustable PVC Outfeed Stand

## THE WINNER:

Here's an outfeed roller stand that you can build in less than an hour from inexpensive polyvinyl chloride (PVC) pipe available at any home center. What makes this stand different from most roller stands is that – through a variety of adjustments – it can be used on uneven floors while keeping the roller parallel to the sawtable surface. The stand easily breaks down into two parts for storage.

From the slotted collar down, the stand is made from 1 1/4"-diameter pipe. Use 1"-diameter pipe for the riser post and arms. All of the joints are glued together except for the pivot point at the T-fitting below the collar and the spot where the arms insert into the T (these are a friction fit).

To adjust the height of the roller, loosen the hose clamp and move the riser post up or down as needed. Fine adjustments can be made by tilting the roller on its mounting arms. To skew the stand to accommodate uneven ground, the pivot point near the

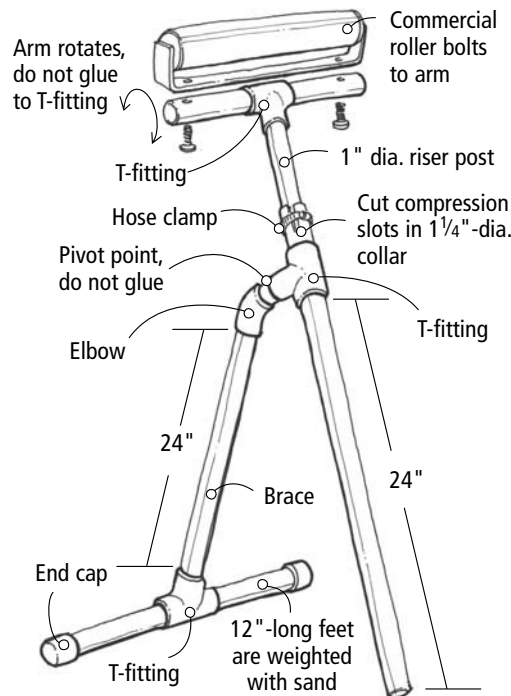

elbow can be rotated, as can the riser post. To further stabilize the stand, I just filled the feet with some sand.

*Michael Peterson  
Colorado Springs, Colorado  
continued on page 20*

## CASH AND PRIZES FOR YOUR TRICKS!

Each issue we publish useful woodworking tricks from our readers and staff members. Next issue, the reader with the winning trick will receive a **Porter-Cable 893PK** router (shown). The 893PK is one of six router designs in the new 890 series designed for maximum performance and ease of use either hand-held or in a router table. The heart of the series is the 2 1/4-horsepower, variable-speed motor with soft-start and electronic feedback to maintain constant speed during operation. This kit is a \$250 value.

Runners-up each receive \$75. When submitting a trick (either by mail or e-mail) you must include your complete mailing address and a daytime phone number. If your trick is selected for publication, an editor will need to contact you. All entries become the property of *Popular Woodworking*. You can send your trick by e-mail to [popwoodtricks@fwpubs.com](mailto:popwoodtricks@fwpubs.com) or mail it to: Tricks of the Trade, *Popular Woodworking*, 4700 E. Galbraith Road, Cincinnati, OH 45236.



## The Delta Edge

Start building a  
Delta shop with this  
**\$50** rebate.



### 28-206, 14" Industrial Band Saw

#### This Band Saw Is Simply The Best

- A fully-featured saw with 1 HP motor
- Patented quick-release tension lever
- Large 16" x 16" cast-iron tilting table.
- Integrated 4" dust collection port
- Precision balanced 9 spoke wheels



### 22-580, 13" Two Speed Finishing Planer

#### Saves Time, Less Sanding

- Does the work for you by dimensioning on one speed, and finishing on the second speed
- This award-winning planer has won every portable planer review ever entered

For your nearest dealer, visit  
[deltamachinery.com/rebate](http://deltamachinery.com/rebate).  
Rebate valid 11/1/03 through 2/15/04.



Your achievement. Our tools.

## TRICKS OF THE TRADE

continued from page 19

### Installing Threaded Inserts

Metal threaded inserts make great connectors for bolting together jigs and other projects that need to be disassembled easily. The problem with threaded inserts is that they are tricky to install perpendicular to the workpiece surface because they tend to cock as you drive them in. Here's how I do it:

For hardwoods, I use the drill press to bore a hole that is  $\frac{1}{64}$ " diameter less than the outside diameter of the insert I am using. For softwoods, I make the hole  $\frac{1}{32}$ " less, and for medium-density fiberboard (MDF), I bore the hole the same diameter as the insert. Also, I drill the hole about  $\frac{1}{8}$ " deeper than the length of the insert.

Next, I make a mixture of epoxy and sawdust, and spread it judiciously on the insert's threads and around the inside of the bored hole. Don't use so much epoxy that it will pool up in the hole. Afterward, I screw a short hex-head cap screw (using a washer) completely into the insert and drive the insert completely into its hole with a wrench, then

remove the screw. If any epoxy backs up into the interior threads, I brush them clean immediately with a bit of denatured alcohol, then insert and remove a bolt to clear the threads, repeating if necessary.

To square the insert to the workpiece surface, I install a 4"-long headless bolt or threaded rod into the insert, oiling the bolt to

ensure easy removal. I use a small square to set the bolt vertically in all directions, then I let the epoxy cure. I've never had a failure using this method, nor has a threaded insert ever pulled out of the hole.

Steve Metz  
Coopersburg, Pennsylvania  
continued on page 22

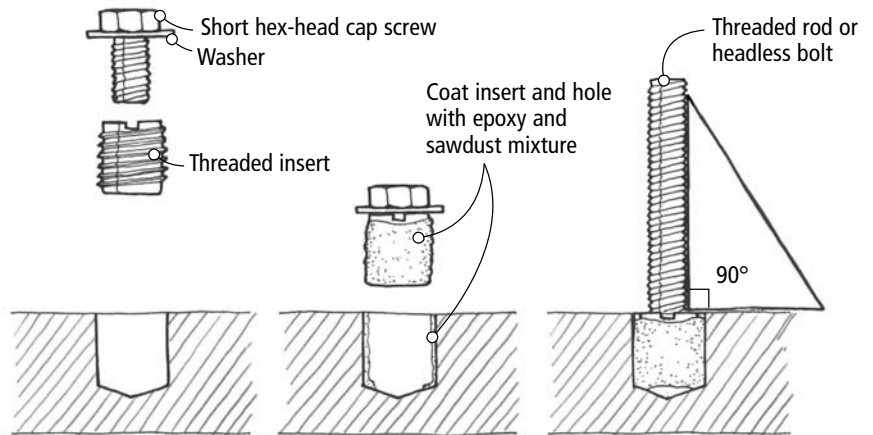

# Pocket Hole Screws from the Source!

- Square Drive Stops Driver Bit Slippage!
- Hardened Steel for Extra Strength
- Available in Coarse OR Fine Thread
- Available in #6 & #8 in both 1-1/4", and 1-1/2" lengths!
- Kreg Jigs & Pocket Hole Supplies
- Over 750 Other Types of Square Drive Screws in Stock!

Warning: Professional caricature, never store screws in mouth!

**Write for FREE Catalog!**

## McFEELY'S

SQUARE DRIVE SCREWS

PO Box 11169 • Dept PWWMD • Lynchburg • VA • 24506  
Toll Free 1-800-443-7937 or at [www.mcfelys.com](http://www.mcfelys.com)

CIRCLE NO. 134 ON FREE INFORMATION CARD.

## ROUTER & TABLE SAW SYSTEMS

- **Combination Router & Table Saw Fences**  
Micro Adjustable, Accurate to 1/1000 of an inch
- **Router Tables, Table Saw Extension and Floating Infeed/Outfeed Tables**  
Available in Solid Phenolic or Melamine
- **Complete Table Saw Upgrade Systems**  
Available for virtually all Cabinet & Contractor Saws
- **True Zero Clearance Miter/Cutoff Sled**  
Micro-Adjustable, Positive Detents Every 1/2 Degree
- **Table Mounted Router Lift System**  
Raise & Lower a Router with 1/1000 of an inch precision
- **And Much More...**

**BEST NEW TOOL**  
POPULAR WOODWORKING

**SMART MITER**  
Voted Best New Tool by Popular Woodworking!

**AMERICAN CHOICE**  
WOODWORKING

**Router Table Systems Available**

Jointech Routing Center

# FREE CATALOG!

**CALL TODAY!**  
**1-800-619-1288**  
[www.jointech.com](http://www.jointech.com)

**JOINTECH**  
ULTRA-PRECISION WOODWORKING SYSTEMS

Jointech, Inc. is an official dealer for products made by:

**GENERAL INTERNATIONAL**

CIRCLE NO. 126 ON FREE INFORMATION CARD.

# Makita®

# MForce™



## CORDLESS DRILL SERIES

### MAIL-IN REBATE

BUY 12V  
GET ▶ **\$20** Rebate

BUY 14.4V  
GET ▶ **\$30** Rebate

BUY 18V  
GET ▶ **\$40** Rebate

BUY 18V  
Combo Kit  
GET ▶ **\$50** Rebate



MForce™ DRILL SERIES  
18V, 14.4V, 12V

1-800-4MAKITA  
MAKITATOOLS.COM

# SHIFT TO FULL POWER.™

## SWEEPSTAKES

# GRAND PRIZE



## QuadSport® Race Pack

Models LT-Z400, LT-Z250 and LT80

(2) **First Prizes**  
A Day for Two with

TEAM SUZUKI RACING

(10) **Second Prizes**  
Makita 18V MForce™  
4-pc. Combo Kit Model DK1052DL

(15) **Third Prizes**  
Makita 12V Impact Driver Kit  
Model 6916DWDE

Professional  
rider with  
advanced  
skills shown.

For Official Sweepstakes Rules, see pamphlet at participating Makita distributors. No purchase necessary in order to enter sweepstakes. Void where prohibited. Must be 18 years or older to enter. Ends 12/31/03.

continued from page 20

## Linking Pipe Clamps

As many long pipe clamps as I own, I seem to always find myself in need of more when assembling large cases. Fortunately, I've found that I can easily employ two shorter clamps to make a long one. After hanging the heads of the two clamps over the ends of the case, I just twist the sliding jaws 90° as shown, effectively hooking them together.

*Al Souse  
White Cross Fields, Minnesota*

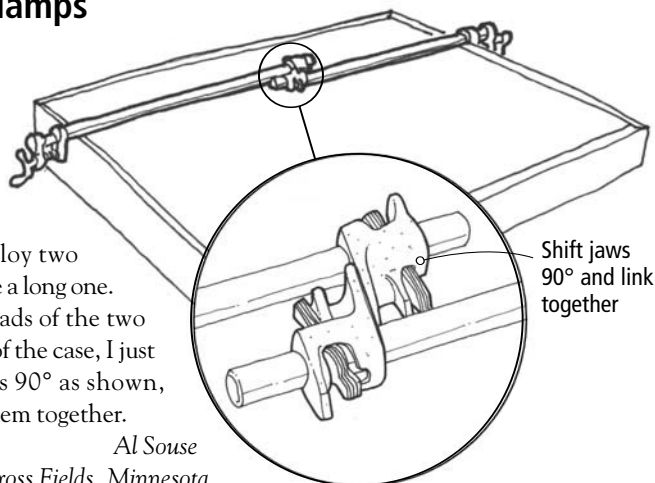

Shift jaws 90° and link together

## Simple and Flexible Plane Blade Protection

If you store your hand planes in a tool box, you know that one wrong move as you go to retrieve or return one can be disastrous. I've knocked planes against other tools and I always seem to chip the cutting iron on something else hard and metal.

The fix is simple. Get a wide rubber band – the kind that bundles asparagus and broccoli at the grocery store. Wrap it around the plane body so the band covers the mouth of the plane. Problem solved.

*Christopher Schwarz  
executive editor, Popular Woodworking*

## Find Where You're Grinding With a Magic Marker

To achieve a consistent bevel when regrinding your chisel, it's important to steady the chisel vertically as you move it side-to-side against the wheel. It's also important that the wheel contact the bevel at its center, between the cutting edge and the heel of the bevel.

Unfortunately, if your grip is less than steady, you can lose your center of reference – ending up with a bunch of different facets on the face of the bevel. To correct this, you need to start grinding at the center again, but your new grind can be hard to distinguish among the multiple facets. The solution? Just drag a wide marker across the entire bevel and start over. Your new grinding mark will be readily apparent.

*Smiley Turner  
Madison, Wisconsin*

## Emery Boards for Sanding in Tight Spaces

Emery boards – sold at your local drugstore for fingernail care – are great for removing burrs from the underside of scrollsawn workpieces. These Popsicle stick-shaped sanding sticks can get into tight places and also can be used for light shaping of curved surfaces on softwoods and some hardwoods.

*Austin Schmidt  
Lexington, Ohio*

## Better Bit Storage – Yes, You Can Mix 1/2" and 1/4" Shanks

I recently built a router table that included drawers with drilled holes to accommodate my growing collection of nearly 100 bits. The problem was how to properly organize them. I like to store bits according to their use – straight bits, flush-trim bits, edging bits, etc. – but some have 1/4"-diameter shanks and some have 1/2"-diameter shanks. I wanted to arrange the bits in proper order regardless of shank size.

My solution was to drill 1/2"-diameter holes for all of the bits and then use wood-

en "bushings" as inserts for the 1/4"-diameter bits as needed. To make the bushings, I cut short lengths of 1/2"-diameter dowel, then bored a 3/32"-diameter hole in the center using my drill press.

The easiest way to do this is to first bore a 1/2"-diameter hole in a piece of thick scrap clamped to the drill-press table. Then, without moving the scrap, you can insert a section of dowel into the hole and replace the 1/2"-diameter bit with a 3/32"-diameter bit. You now can drill a hole easily in the center of the dowel, holding it with pliers or a clamp to prevent it from spinning. It's wise to make a good supply of these for future use.

*Jack Stauffer  
Lewisburg, Tennessee  
continued on page 24*

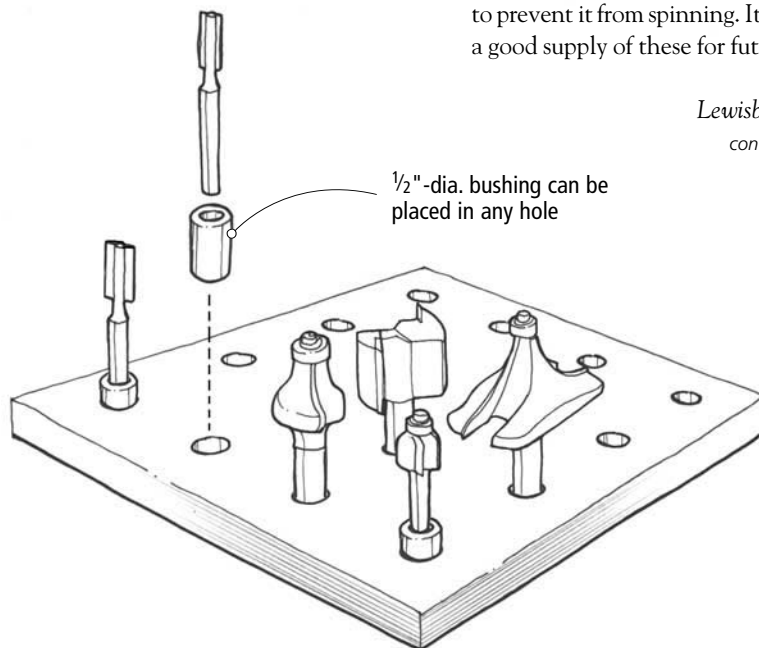

1/2"-dia. bushing can be placed in any hole





# GRIZZLY PRESENTS

## THE ULTIMATE 10" CONTRACTOR-STYLE TABLESAW!

We have re-vamped our new contractor-style saw by taking 20 years of customer comments and in-use experience and applying them to this new saw. We feel that there is no contractor-style saw on the market (at any price) that can compare in quality to this one. *Check out the features below.*

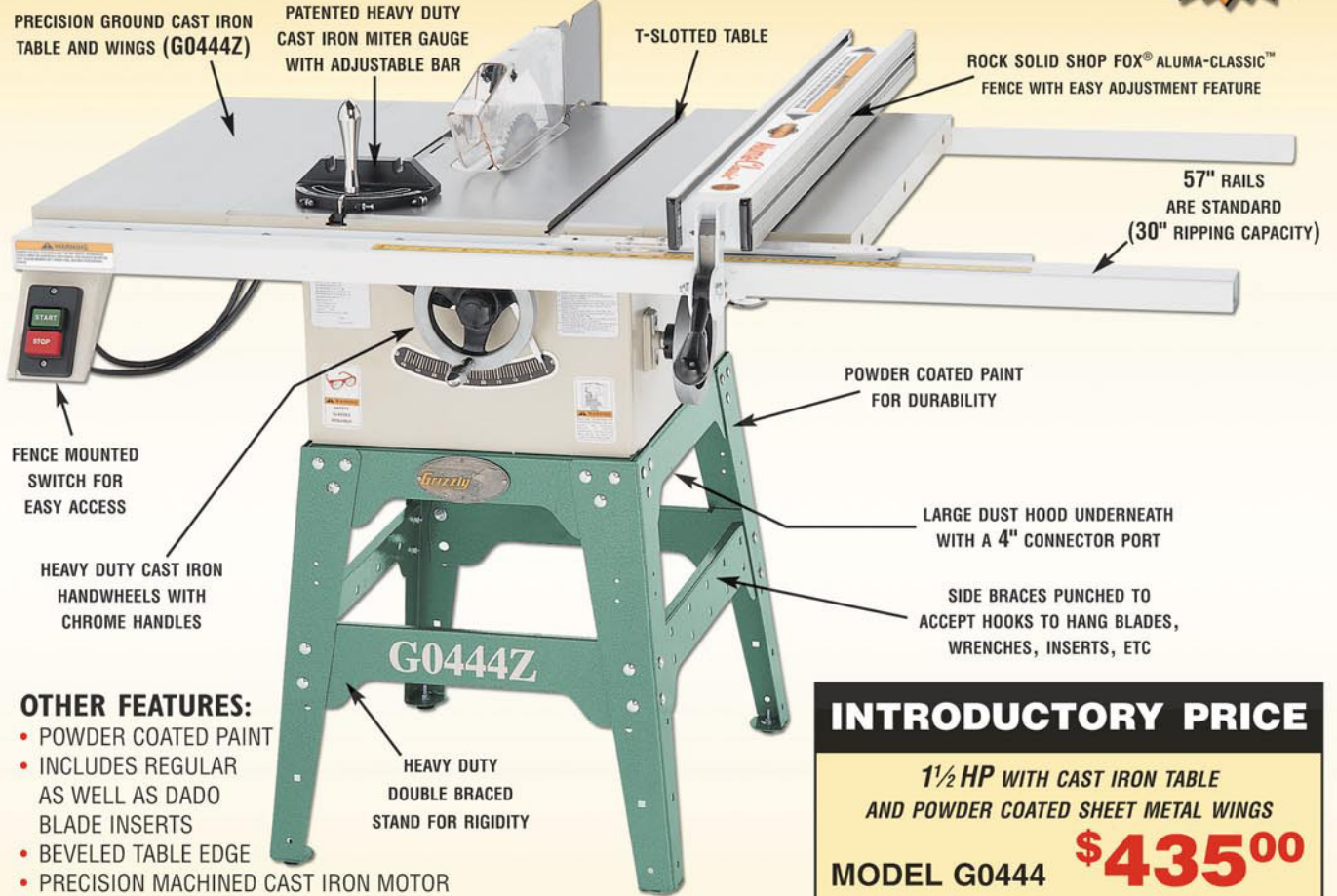

PRECISION GROUND CAST IRON TABLE AND WINGS (G0444Z)

PATENTED HEAVY DUTY CAST IRON MITER GAUGE WITH ADJUSTABLE BAR

T-SLOTTED TABLE

ROCK SOLID SHOP FOX® ALUMA-CLASSIC™ FENCE WITH EASY ADJUSTMENT FEATURE

57" RAILS ARE STANDARD (30" RIPPING CAPACITY)

POWDER COATED PAINT FOR DURABILITY

LARGE DUST HOOD UNDERNEATH WITH A 4" CONNECTOR PORT

SIDE BRACES PUNCHED TO ACCEPT HOOKS TO HANG BLADES, WRENCHES, INSERTS, ETC

FENCE MOUNTED SWITCH FOR EASY ACCESS

HEAVY DUTY CAST IRON HANDWHEELS WITH CHROME HANDLES

HEAVY DUTY DOUBLE BRACED STAND FOR RIGIDITY

### OTHER FEATURES:

- POWDER COATED PAINT
- INCLUDES REGULAR AS WELL AS DADO BLADE INSERTS
- BEVELED TABLE EDGE
- PRECISION MACHINED CAST IRON MOTOR PULLEY FOR REDUCED VIBRATION
- ALUMA-CLASSIC™ FENCE LIFTS OFF INSTANTLY
- G0444 APPROXIMATE SHIPPING WEIGHT: 276 LBS.
- G0444Z APPROXIMATE SHIPPING WEIGHT: 298 LBS.
- EXTENSION RAILS AVAILABLE TO RIP 50" WIDE

### INTRODUCTORY PRICE

1½ HP WITH CAST IRON TABLE AND POWDER COATED SHEET METAL WINGS

MODEL G0444 **\$435<sup>00</sup>**

2 HP WITH CAST IRON TABLE AND WINGS

MODEL G0444Z **\$525<sup>00</sup>**

**\$75** Shipping ANYWHERE IN LOWER 48 STATES

**MADE IN A ISO 9001 RATED FACTORY**



Grizzly Industrial has a complete line of high quality table saws for every need. Cabinet saws, sliding table saws, industrial rip and jump saws. If you need it, we have it. *Check out our website!*

**grizzly.com**

CUSTOMER SERVICE: (570) 546-9663 • FAX: 1-800-438-5901

**1-800-523-4777**

- 2 Overseas quality control offices staffed with qualified Grizzly engineers.
- Most orders shipped within 24 hours.

- 24 Hour ordering by phone or online
- Our huge parts department is stocked with over a million parts at all times.

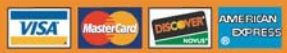

**3 SHOWROOM & WAREHOUSE LOCATIONS: BELLINGHAM, WA • SPRINGFIELD, MO • MUNCY, PA**

MEDIA CODE AD1927

544003658

## TRICKS OF THE TRADE

continued from page 22

### Mark Visible Lines On Dark Woods with Ease

While in the process of hand-cutting dovetails on nearly 40 walnut drawers recently, I realized that my accuracy was severely limited by my inability to clearly see the layout lines on the dark wood. I decided to do a little research and trucked off to my nearby office-supply store with a piece of walnut. I marked the end grain and face grain of the walnut using every pen in the store. Most inks bled badly into the wood, making wide lines despite having a fine tip. Many were as difficult to see as a regular pencil line. Finally, I found a pen that did the trick: the Pilot P-500 gel roller pen. It produces a fine, reflective line that sits on the surface without wicking into the wood. Blue and black ink both showed well. Check it out next time you're working with dark wood.

Bill Tindall  
Church Hill, Tennessee

### Tidy Countersinking

When building a garden swing recently, I needed to countersink a lot of screws in the slats in a uniform manner without chipping out the wood. I decided to cut the countersinks on my router table using a V-bit. I set the fence to register the countersink hole halfway across the width of a slat and clamped a stop block to the fence to locate the hole

the proper distance in from the end of each slat. After adjusting the bit to the proper height, I simply placed each slat upside down against the fence and the stop block, and lowered it onto the spinning bit. The holes came out perfectly clean and made centering the pilot holes for the screws a cinch.

Maurice Davison  
Coarsegold, California  
continued on page 26

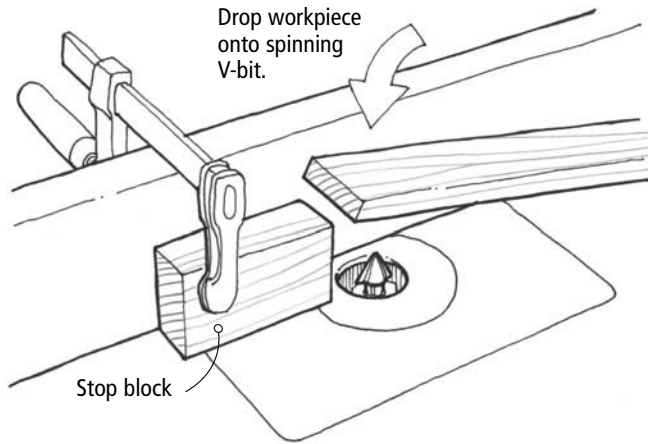

**The Amazing**  
**HAWK**  
Precision Scroll Saw

**Cuts hardwoods up to 2<sup>5</sup>/<sub>8</sub>" thick with less than 1/64" turning radius**

- Perfect for hobbyists and professionals
- Variable speed with vibration-free performance
- 3 models to choose from
- Loaded with NEW features:  
Dura-Torque power system  
3 second blade change  
Automatic blade tensioning
- Made in USA quality, sold factory direct

**No obligation. Call us toll free, 1-800-487-2623**

Ask for a **FREE** Demonstration VIDEO and FACT KIT

Hawk Woodworking Tools, P.O. Box 369  
Harrisonville, MO 64701 S03011

[www.hawkwoodworkingtools.com](http://www.hawkwoodworkingtools.com)  
© 2003 rbindustries, inc.

CIRCLE NO. 143 ON FREE INFORMATION CARD.

If you are in a woodworking business... this could be the most valuable tool in your office™.

Please call 1-800-645-9292 for your 532 page catalog.

**FREE** to woodworking businesses.

visit us at [woodworker.com](http://woodworker.com)

Visit us at [woodworker.com](http://woodworker.com)

**Woodworker's Supply**  
Since 1972  
"When the papers buy their tools"

MASTER INDUSTRIAL CATALOG  
SPRING/SUMMER 2003

"The Big Book of Woodworking"

- ✓ Biggest Selection
- ✓ Hundreds of New Products
- ✓ Fast Delivery

CIRCLE NO. 163 ON FREE INFORMATION CARD.

**WHITECHAPEL LTD**  
THE WORLD'S FINEST HARDWARE

Free 216 page color catalog: 1-307-739-9478  
Web: [whitechapel-ltd.com](http://whitechapel-ltd.com)

French armor hinges available in six sizes.

CIRCLE NO. 154 ON FREE INFORMATION CARD.

**Adams Wood Products**  
LTD., LP.

**STOCK ITEMS**  
**NO MINIMUM ORDERS**  
-OR-  
**WE WILL MAKE PRODUCTION RUNS OF YOUR PART**

Made in Tennessee  
By American Craftsmen

913 LEGS  
113 REEDED BASE W/206 LEG

CHAIR LEGS  
ACR08  
AMD08

BUN LEGS  
A0556

FR STYLE QUEEN ANNE LEGS

FINIALS  
A0851

404 CHAIR KITS

P.O. Box 728, Dept. PW17  
Morristown, TN 37815-0728  
Phone 423-587-2942 • Fax 423-586-2188  
[www.adamswoodproducts.com](http://www.adamswoodproducts.com) **FREE COLOR CATALOG**

CIRCLE NO. 100 ON FREE INFORMATION CARD.

# Get a sleighful of savings with the MultiMaster Holiday Kit.



## A \$399 value for just \$299. Kit contains:

- MultiMaster Start
- Profile Sanding kit
- Sanding pad
- Rasp
- HSS Segment blade
- Flush Cut Wood blade
- Mini E-Cut set
- E-Cut blade
- Carbide Grout blade
- Scraper blade
- 30 Sanding sheets
- Screws and wrench



Offer expires December 31, 2003

- Metal SuperCase box

You'll be ho-ho-hoing all the way to the bank with this great Holiday MultiMaster Kit from FEIN.

Purchased individually, you'd expect to pay about \$399 for all these goodies. Buy the promotional kit for \$299 and you save a cool \$100. Kit even includes the brand new FEIN Profile Sanding attachment and profiles. Call **1-800-441-9878** for more details and a dealer near you, or visit us at [www.feinus.com](http://www.feinus.com).

*Finishing  
is just  
the beginning*

**Fein** 

CIRCLE NO. 112 ON FREE INFORMATION CARD.

continued from page 24

## Wrapping Grain

One of the nicest features a small box can have is when the grain runs uninterrupted around all four corners. Not only is this visually pleasing, it also adds structural integrity because wood movement will be consistent at the corners. It's a mystifying trick for some, but it's not difficult. Begin with stock that is  $\frac{1}{4}$ " thicker than twice the thickness of the box walls and  $\frac{1}{4}$ " longer than the length of two contiguous parts, as shown in Step 1. Label the outermost surfaces for future reference, then resaw this stock and plane the two resawn pieces to final thickness, removing as little wood as possible. Next, cross-cut each piece to yield two contiguous pieces, as shown in Step 2. Label the pieces near the ends for later reassembly in the orientation shown. After mitering the ends and assembling the box as shown in Step 3, one pair of diagonally opposed corners will display a bookmatched joint and the other corners will display a continuous flow of grain. **PW**

Geoffrey Noden  
Trenton, New Jersey

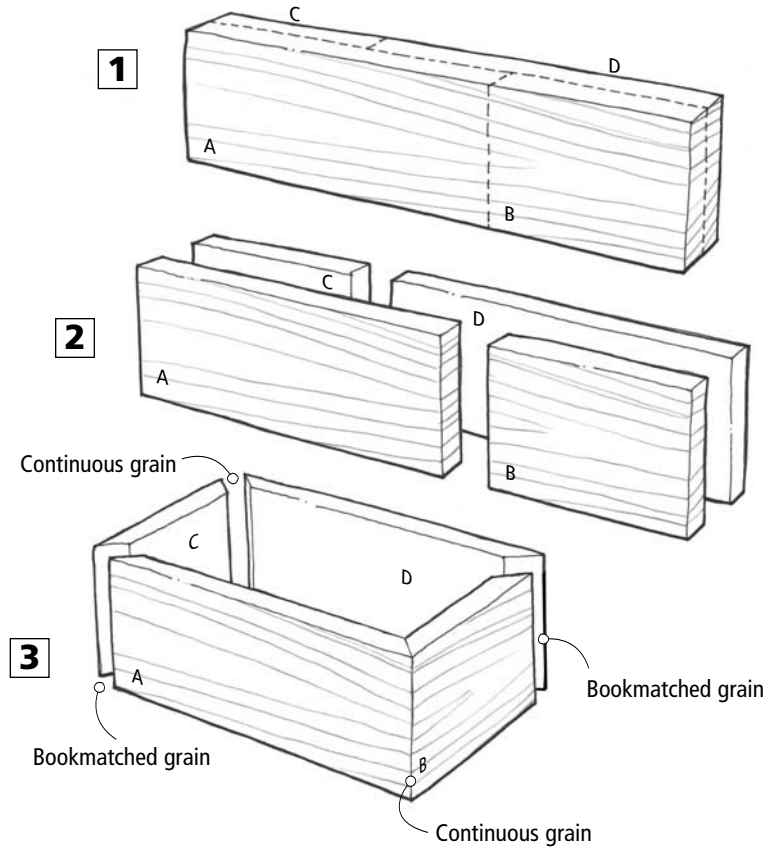

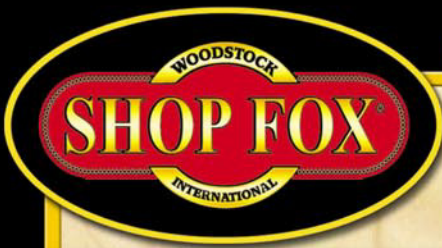

FASTEST GROWING MACHINERY LINE IN THE U.S.A.

# INNOVATIVE PRODUCTS DESIGNED FOR PRACTICAL USE

**ASK** ANY FINE WOODWORKER AND HE WILL TELL YOU THIS:  
**QUALITY MACHINES  
PRODUCE QUALITY RESULTS.**

THAT IS WHY WE DESIGN OUR MACHINES TO THE MOST STRINGENT STANDARDS, TRIPLE CHECK EACH ONE FOR QUALITY ASSURANCE AND BACK EVERY MACHINE WITH A FULL TWO-YEAR WARRANTY!

**SEE OUR EVER EXPANDING  
LINE OF MACHINERY  
AT A QUALITY DEALER NEAR YOU.**



**5 HP 20" PLANER  
W1683  
4 BLADE  
CUTTERHEAD!**

## SHOP FOX® 5 HP 20" PLANER

**P**repare yourself for the heavyweight champion of planers! This workhorse has all the features you need plus a few extra for ease of use. The specially designed cutterhead with a redefined blade angle leaves smoother finishes on any type of wood. With a large 20" capacity and rugged cast iron construction, this is the last planer you should ever need.

- Powerful 5 HP, single-phase, TEFC motor
- 2 Chromed upper rollers
- Rubber outfeed roller
- Anti-kickback design
- Precision ground cast iron table
- Magnetic safety switch
- Powder coated paint
- Approx. shipping weight: 840 lbs.

**IN STOCK  
NOW!**



SHOP FOX® is a registered trademark of Woodstock International, Inc.

## SHOP FOX® 6" JOINTER

This outstanding machine combines innovative features with time-tested favorites to give the discriminating craftsman the quality, convenience and performance standards he demands. Here are just a few of the features that put our 6" Jointer in a class of its own:

**W1679**

- 1 HP, 110V motor
- Precision ground cast iron tables
- Extra large cast iron fence
- Simple fence adjustment
- Post mounted control switch
- Silky-smooth handwheel table adjustment
- Powder coated paint
- Approx. shipping weight: 300 lbs.



## SHOP FOX® 8" JOINTER

Built like a tank, yet refined and precise, our 8" Jointer is designed to handle your extra large boards with accuracy and ease. Never before has the woodworking world seen such a blend of design and style.



**W1684**

- 2 HP, 220V, single-phase, TEFC motor
- Extra long 70" precision ground cast iron table!
- Center mounted tilting fence
- Oversized welded steel stand
- Post mounted magnetic control switch w/thermal overload
- Silky-smooth handwheel table adjustment
- Powder coated paint
- Approx. shipping weight: 495 lbs.

CALL FOR THE LOCATION OF A DEALER NEAR YOU!

**1-800-840-8420**

VISIT OUR WEBSITE FOR MORE SHOP FOX® PRODUCTS

**SHOPFOX.BIZ**

sales@woodstockinternational.com



494502958

# Frame Miter Joints

These elegant joints are difficult to cut and clamp. These jigs can help.

The only frame joint that doesn't leave a bit of end grain exposed is the miter joint. Given that it's almost invisible when done right, it's visually appealing, so you see it used for picture frames, for architectural trim, when assembling mouldings and occasionally in face or door frames.

But it can be a problematic joint.

Structurally, it's a bit weak. Because it mates one tangentially cut end-grain surface (sometimes called "short grain") with another, it's weaker than a long-grain-to-long-grain joint. It's stronger than end-grain to end-grain, but not much. Run some fasteners into a miter joint and you're driving them into end grain, where they won't hold well. Angling the fasteners helps, but not a lot.

Also, a miter is tough to cut accurately. Haven't we all struggled with a frame that isn't square and has joints that don't close because some of the cuts were half a degree off perfect? Try all sorts of approaches – miter saws, table-saw jigs, stationary sanders, even hand tools such as block planes and miter



Photos by the author

Spline and dovetail keys are basically just exposed splines. After the joint is glued up, just saw or rout a slot through its edge, then glue a key into the slot. Typically, the key is a contrasting wood so it can stand out.

trimmers – but nothing seems to work.

On top of that, joint assembly is maddening because you have to find a way to prevent the mating pieces from sliding out of line when you apply clamping pressure.

If that isn't enough to make you shy away, wood movement stresses the joint and degrades its appearance, especially with stock

that is wider than 3". As the wood expands, the joint tends to open at the outside; when it contracts, the joint opens at the inside. The wider the stock and the more unstable the species, the more pronounced the effect.

For this reason, it's a good idea to limit the stock width you join with miters. Picture framers and trim carpenters compensate for this effect by layering several thinner mouldings to create large frames.

## Making the Cuts

Cutting the miters seems to be a simple task. You can use several different types of power saws, but the real trick is in cutting a precise angle that yields a square joint.

Power miter saws and radial-arm saws have adjustment points that can create inaccuracies. A detent (a factory-made "stop")

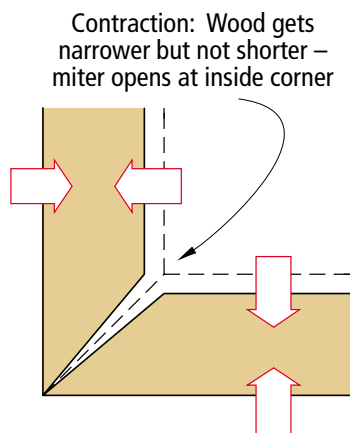

Contraction: Wood gets narrower but not shorter – miter opens at inside corner

**Effect of wood movement**

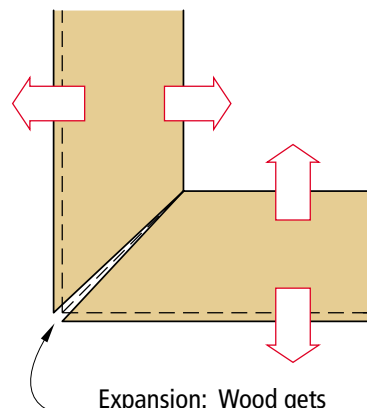

Expansion: Wood gets wider but not longer – miter opens at outside corner

by Bill Hylton

*Bill Hylton is the author of several books on router woodworking and furniture making. He will be giving seminars at select WoodWorks 2003 shows. See [woodworks2003.com](http://woodworks2003.com) for more information.*

for the blade at common cutting angles) can have just a tiny bit of play. The pointer on the scale can be off a hair. The tools have pivot points that can develop play.

Nevertheless, these tools will produce acceptable results. And having a well-tuned saw helps. When you make a critical cut, check the angle against a reliable angle square. For 45° angles, a plastic drafting triangle is both accurate and inexpensive. The other critical point is that your stock must be cut precisely to length. Even small variances can spoil the fit of the assembled frame.

A woodworker who gets little practice may get better results using a sliding cross-cut table or a miter sled on the table saw. Sliding tables are pricey, and not all saws can accommodate one. An adjustable miter sled is more reasonably priced. Or you can make one yourself, as shown at right.

The advantage of these devices compared to a miter gauge is that the work is immobilized against the fence and base throughout the cut – you aren't sliding the work itself across the table of the saw.

Presuming that your goal is to produce a square corner and not necessarily to produce precise, individual 45° cuts, you can make a miter sled for the table saw that will do the trick. A square-cornered block ensures that your assembled miters will be square.

While there's certainly more than one way to produce the sled, the one that worked for me was to assemble the base, runners and fence, then to saw into the base. I next cut the back block square, scribed the diagonals on the block and sawed it in half along one of them. I used the second scribed diagonal to position the now-triangular block on the sled's base. The result is a sled that helps me cut clean miters that form perfect right-angle joints. No fuss, no adjustments and no fine-tuning are required.

### Clamping is Job No. 1

The true challenge in gluing up a miter joint is applying clamping pressure. You need to force the mating surfaces together, which requires pressure perpendicular to the glue line, but you also need to simultaneously pull the components of the frame together.

There are all sorts of specialty clamps on the market. You can buy corner clamps for clamping individual miter joints. There are

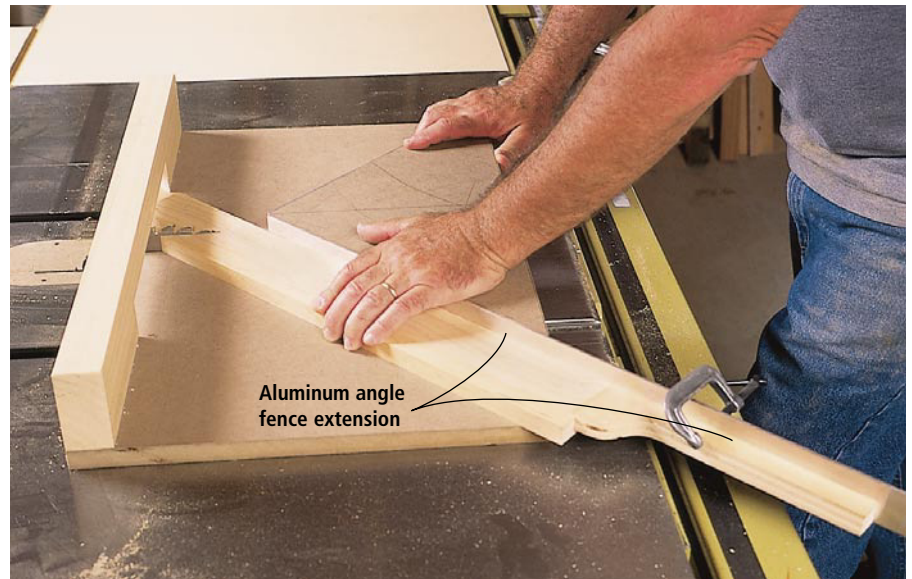
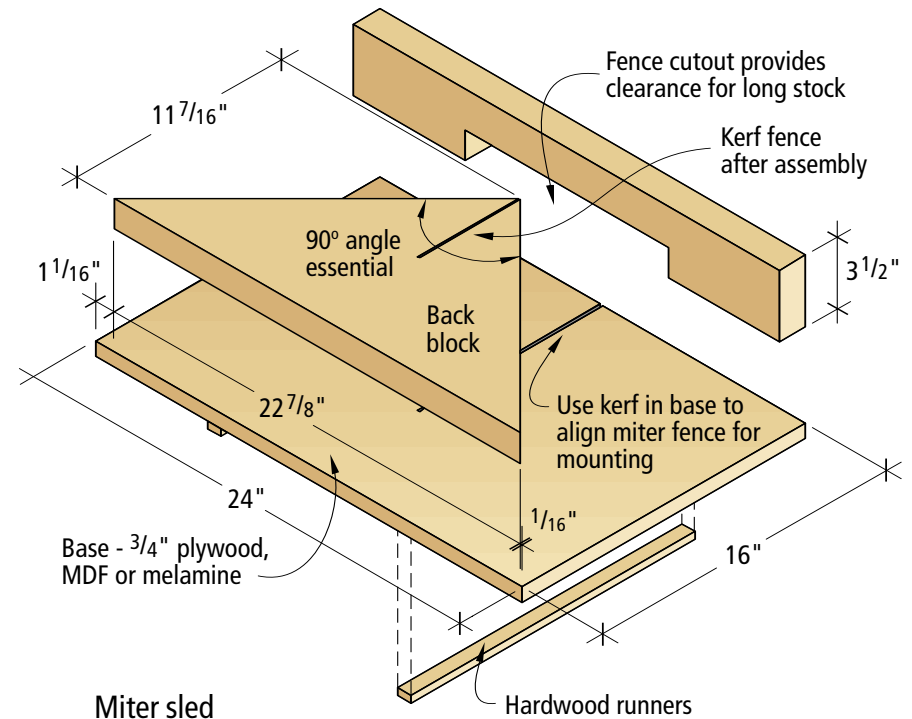

A miter sled for the table saw will produce perfect right-angle joints. Stops clamped to the aluminum angle fence extensions ensure parts will be properly sized.

some setups for clamping a complete frame at once. An effective and inexpensive band clamp, for example, surrounds the frame and pulls its parts together.

I personally favor some homebrewed approaches that use general-purpose clamps.

Miter clamping cauls provide angled surfaces so you can apply a clamp perpendicular

to the glue seam. Clamp the cauls to the mating parts, then close the joint and apply the clamp to it. Two cauls allow you to clamp a single joint and they work equally well for clamping case miters.

You can make them by cutting V-grooves to create the clamping surfaces, or you can attach beveled blocks to strips of plywood.

Miter clamping cauls help you apply pressure at right angles to the joint's seam.

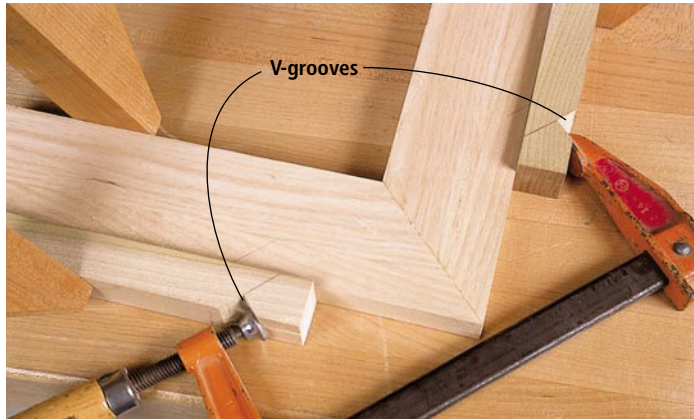

You also can use four clamping blocks with V-shaped notches cut into them. This works where you want to assemble four joints at once – a complete frame – as opposed to just one joint at a time.

One way to use the blocks is to mount them to a base. The base provides a flat surface to ensure the frame isn't twisted, and the V-blocks capture the frame corners to ensure they are square. It's particularly useful for multiples and for very large frames, where the support of the base is beneficial.

I set up the board after at least one frame is cut so I can use its parts to position the blocks that are screwed to the base. Note that only two of the V-blocks are screwed to the base. At the other two corners, you fasten cleats to the base. Clamping pressure is applied by twin wedges driven between the cleats and the loose V-blocks. To prevent squeeze-out from bonding the frame to the base or blocks, wax them liberally.

For the one-off frame, you can use the V-blocks with a brace of bar clamps and several strips of packing tape. Glue the frame and secure each joint with packing tape. Set the V-blocks at the frame corners and apply the bar clamps diagonally. Alternate from clamp to clamp as you tighten them to avoid distorting the frame.

## Call for Reinforcement

I've found that miters can be reinforced in a number of different ways.

- Picture framers commonly use nails. The joint needs to be securely clamped so the hammer's impact doesn't knock the parts out of kilter. Bear in mind that nails driven straight into end grain don't hold that well. You can improve the joint slightly by driving the nail on an angle to the grain.

- Splines are pretty easy to incorporate, and you can hide them inside the joint. (Splines were discussed in the October 2003 issue of *Popular Woodworking* – available at [popwood.com](http://popwood.com) – so we won't repeat that here.)

- Biscuits also can be used. If the frame members are more than 2 1/4" wide, you can use standard No. 20 biscuits. You can use smaller biscuits – No. 10s, No. 0s or mini-biscuits – for narrower frames.

- Dowels are another option, but they are tricky to align, so I don't recommend using them with this joint.

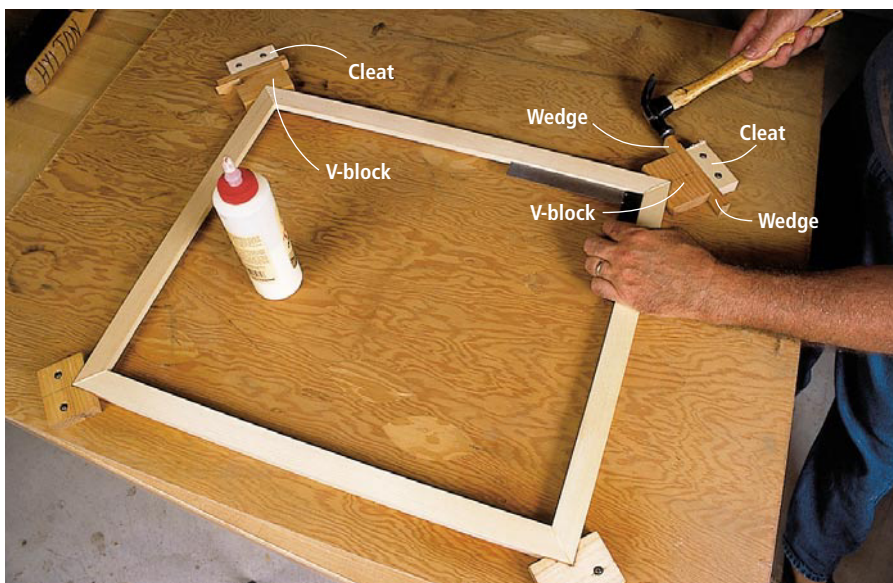

Screw V-blocks to a plywood base to make a frame-clamping jig. Pressure is applied with pairs of wedges. Positioning the blocks – using frame parts – before gluing the frame takes only a minute or two.



Packing tape holds glued miters together while you apply V-blocks and clamps. Apply bar or pipe clamps on the diagonals and alternate tightening to avoid distorting the frame.



## Unlock the 'Keys'

A reinforcement I like for frame miters is the key, either a spline or a dovetail, to add a subtle embellishment to the joint.

Make sure you cut a slot for the key after the joint is glued. For a deep slot – one cut into a wide frame – you can make it on the table saw, while you can cut a shallow slot using your the router table.

The jig shown at right works on either the table saw or the router table. On the latter, you can use it by sliding it along the fence to cut with a bit or by sliding it across the tabletop to cut with a slot cutter.

This approach enables you to use a dovetail key, but the table saw can make a much-deeper cut, which is important for frames that have wide members.

Construction should be evident from the drawing. Miter the ends of the two frame supports, then glue and screw them to the plywood back. These supports must be at right angles to each other. In this form, it can be used flat on the tabletop. If you use the jig upright braced against the fence, add the fence hook (seen in the photo at right) to it.

However you orient the jig, the frame is set into it. You can hold it tight with a spring clamp or two. Position the jig and frame against the fence and make the cut.

When using splines, you should make the cuts on the table saw. Rip strips of stock – a contrasting wood is preferred – to the appropriate thickness. If necessary, plane them to fit. Crosscut the strips into little triangles and glue one into each slot. When the glue dries, trim them flush.

Dovetail keys are easiest to cut on a router table. After slotting the frame, cut the keys using the same bit and height setting. The only change in setup is to swing the fence over the bit, housing most of it. Start with an oversized pin and methodically trim it to fit the slot. When you've got a good fit, rip the pin from the board. Repeat the process until you have enough key stock. Then you can simply cut the stock into short keys and glue a key into each slot.

When the glue dries, the keys must be trimmed flush. Saw off the keys as close as possible, then trim the remaining stubs flush with a block plane (work from the corner in, so you don't tear out splinters of the keys) or sand the stubs flush. **PW**

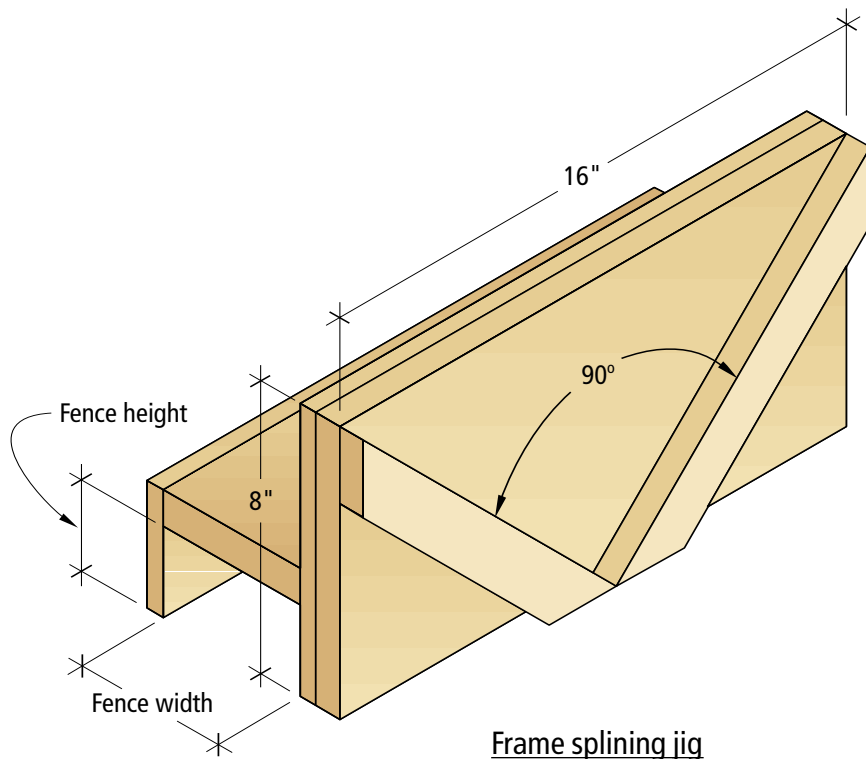

**Frame splining jig**

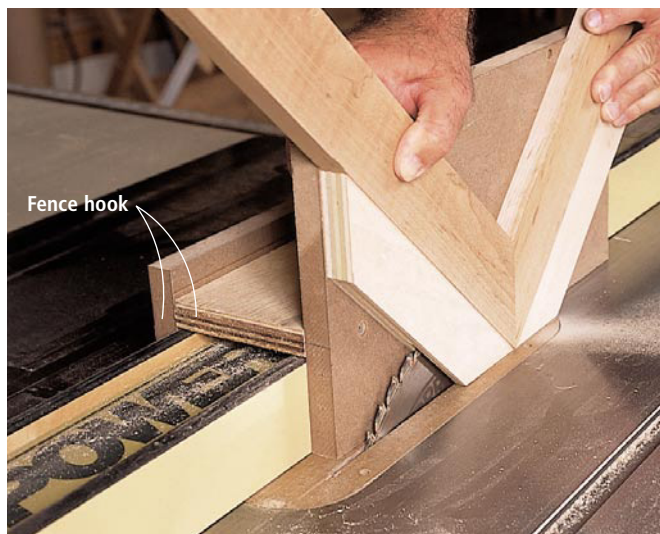

You can cut slots for spline keys on the table saw. A shop-made jig that straddles the rip fence holds the assembled frame.



You can cut slots for dovetail keys on the router table using the same type of jig. The slot can be centered easily by turning the frame around in the jig after the initial cut, then making a second pass.

## Trend Airshield Protects Against Dust and Debris

A face shield was one piece of safety equipment I never made a habit of using. Then I took up turning and my perception changed quickly. Not only did flying chips and fine dust get my attention, but the very real possibility of a chunk of wood flying off the lathe pushed my safety button. It seems every turner has at least one such horror story.

I was about to buy a typical face shield, aware that fogging and dusty insides are an unfortunate reality, when I discovered the Airshield by Trend, an established British company just entering the U.S. market.

I've had a chance to use the Airshield for several months now, and not only do I find myself reaching for it when I'm firing up the lathe, but also when doing dusty routing operations, extended table-saw work and re-sawing on the band saw.

The polycarbonate visor does a fine job of protecting the face, but where the Airshield excels is in preventing the inhalation of ambient fine dust. This is accomplished by the filtration of intake air (minimum 4.94 cubic feet per minute) drawn into the enclosed shield area by an on-board, lightweight

battery-powered fan. The fan creates positive air pressure inside the shield to push out rascally dust that might leak in around the seals between the shield and the user's head. As a very pleasant side benefit, the airflow is pleasantly cool, even in hot weather.

There's one downside to the Airshield: The new mask gives off an unpleasant, but not overwhelming, smell. In time, this smell dissipates, and I'm confident it eventually will go away altogether. Think of it as the opposite of a new car's smell.

The total headgear weighs only 1.62 pounds and the Swiss-made fan motor is quiet. It is powered by a rechargeable four-hour NiCad battery (which is included with the Airshield). You can add a second battery pack for eight hours of service.

The flexible and adjustable face seal fits comfortably as it guards against dust entering the face area. The head strap adjusts in two directions to a maximum size of 24½".

The Airshield comes with a charger, main filter, pre-filter, airflow indicator, visor overlay and bag. — *Steve Shanesy*

For more information, circle #170 on Free Information Card.



### SPECIFICATIONS

#### Trend Airshield

Street price: \$275

Battery time: Four hours  
(eight-hour optional)

Motor sound level: 70 db

Weight: 1.62 lbs.

Performance: ●●●●●

Price range: \$\$\$\$

Trend Machinery: 859-485-2080 or  
trend-usa.com or airwareamerica.com

## Primus Smoothing Plane a High-tech Woodie

When it comes to hand tools, I've always been torn between the heritage of my mother (mostly British) and my father (all German).

Usually the British side wins out, as I prefer backsaws to frame saws, for example. But lately I've been intrigued by the German wooden planes from E.C. Emmerich that approach planing a bit differently than the familiar Stanley/Bailey-style planes.

I tested the E.C.E. Primus Reform smoothing plane, the Mercedes-Benz of the E.C.E. line. This 8¾"-long plane has a cherry body that's wedged to a dense, hard-wearing sole made from lignum vitae. The iron is 1⅞" wide and almost ⅛" thick.

Some of the differences between this plane and traditional metal planes were quite nice. The iron is bedded at 50° instead of the 45° found on Stanley bench planes. This higher angle is better for woods that are curly or inherently difficult to plane. You'll experience less tear-out. Also nice is the adjustable throat. With most Stanley planes you have

to disassemble the tool to move the frog forward and close the throat. On the E.C.E. all you do is loosen a screw and nudge the mouthpiece where you want it. The blade-adjustment mechanism is smooth and sweet with zero backlash. And the weight of the tool made it easy to use all day.

On the downside, I didn't much care for the mechanism that pivots the iron left-to-right (called "lateral adjustment" by some). The lever did not give me as much finesse as simply tapping the iron lightly with a hammer. Finally, as with all wooden planes, there is a lot more maintenance necessary with the sole. Whenever the seasons change you need to true the sole or the plane won't work right.

Generally, this plane is less expensive than other high-end smoothers from Lie-Nielsen and Clifton. That, and its unique set of features, make it worth a serious look.

— *Christopher Schwarz*

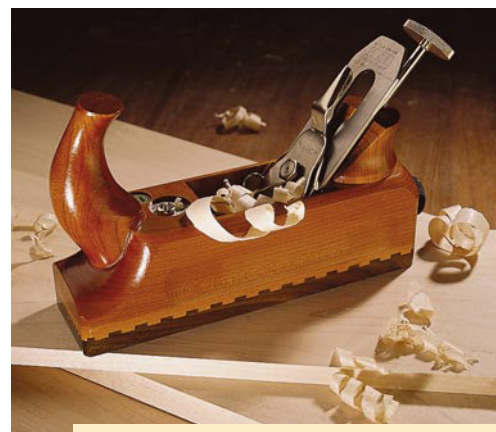

Photo by Al Parrish

### SPECIFICATIONS

#### Primus Reform Smoothing Plane

Street price: \$175

Weight: 2 lbs. 7 oz.

Made in: Germany

Performance: ●●●●○

Price range: \$\$\$

David Warren Direct: 800-724-7758 or  
ecemmerich.com

For more information, circle #171 on Free Information Card.

continued on page 34



CIRCLE NO. 118 ON FREE INFORMATION CARD.

**ROCKLER®**  
WOODWORKING AND HARDWARE

Clamping jaws rotate to easily attach to either horizontal or vertical orientation on any 2X material

**Get universal support everywhere in your shop as well as on the job site...**

**INTRODUCING** our innovative Roller Support with Universal Clamp —exclusively at Rockler

Call or go online to get your **FREE** catalog today! Code 14018

**1-800-403-9736 -or- rockler.com/go/V4323**

CIRCLE NO. 146 ON FREE INFORMATION CARD.

# The Easy Rout.



**The Leigh Dovetail Jig has it all.** Hobbyist or professional, the Leigh D4 Dovetail Jig will ensure you create your best work. Versatility, precision and superb value make the Leigh Dovetail Jig better than the rest. Rout through and half-blind dovetails up to 24" wide in boards up to 1 1/2" thick, with infinitely variable spacing of pins and tails — all on one jig. Plus, rout sliding and angled dovetails easily with the D4. And create decorative Isoloc joints, finger joints, and multiple mortise & tenons effortlessly with Leigh attachments and our exceptional user guides! Make routing easier with Leigh. Call toll free now!

**Call For Your FREE Leigh Catalog Today! 1-800-663-8932**

**LEIGH**  
Joining Tradition With Today

Leigh Industries Ltd., PO Box 357  
Port Coquitlam, BC Canada V3C 4K6  
Toll free 1-800-663-8932 Tel. 604 464-2700  
Fax 604 464-7404 Web www.leighjigs.com

## Freud Shimless Dial-a-Width Dado Stack

If you like using a dado stack, then this new one from Freud will please you to no end. If you hate dado stacks, this one might make you change your mind.

The problem with dados is getting the perfect width cut. Shims are always a pain and make setup awkward. Dado stacks adjusted by a dial are nothing new, but most aren't well-made. Freud's SD608 not only cuts splinter-free, flat-bottomed dados, but the dial-hub adjustment allows the user to sneak up on the perfect width (in .004" increments with each click of the dial) without having to remove the blades from the saw. The blades are of premium quality (as we expect from Freud) and the dial hub can be switched to accommodate either left- or right-tilt saws. — *David Thiel*

For more information, circle #172 on Free Information Card.



### SPECIFICATIONS

**Freud SD608 Dado**

**Street price:** \$270

**Size:** 8", 24-tooth, five chippers

**Performance:** ●●●●●

**Price range:** \$\$\$\$½

**Freud:** 800-334-4107 or freudtools.com

## Ridgid's 5" RO Sander

Sanders aren't exactly sexy things to write about, but Ridgid's new 5" random-orbit sander is pretty hot in the world of smoothing wood.

The R2600 sports a 3-amp variable-speed (7,000 to 12,000 rpm) motor that provides a pleasant soft start and removes material nicely without shaking your hand apart. The soft over-molded grips make it comfortable to use, and we liked the conveniently located power switch. Its bag for dust-collection is efficient and adapts to either 1¼" or 2¼" hoses.

But the best thing about this sander is the "Micro Fiber" hook-and-loop pad. Studded with hundreds of smaller hooks, the paper grabs and doesn't let go. The hooks are supposed to hold up to abuse longer – we'll get back to you on that.

This is a well-made, well-priced tool and we're happy to have it in use in our shop. — *DT*

For more information, circle #173 on Free Information Card.



### SPECIFICATIONS

**Ridgid R2600 Sander**

**Street price:** \$80

**Motor:** 3 amp

**Orbit diameter:** ¾"

**Weight:** 3 lbs.

**Performance:** ●●●●○

**Price range:** \$\$\$

**Ridgid:** 866-539-1710 or ridgid.com

## Taking Doweling to a New Level

For many woodworkers, biscuits have replaced dowels as the "loose tenon" of choice. But some still prefer dowels, and for some jobs dowels still are best.

That's where Dowelmax shines. This meticulously manufactured doweling jig offers a level of precision, stability and versatility not previously available. To make single, double, triple, offset, flush, mitered or "T" ¾" dowel joints, the Dowelmax will guarantee accurate results. While a bit on the expensive side, the machining on the jig is unparalleled. Included in the kit are spacers for a variety of material thicknesses, a distance gauge for accurate panel work, a bit with a stop collar and a great instructional video that helps walk you through all the different possibilities available. — *DT*

For more information, circle #174 on Free Information Card.



### SPECIFICATIONS

**Dowelmax**

**Street price:** \$169 (¼" guides: \$35)

**Performance:** ●●●●○

**Price range:** \$\$\$\$\$

**Dowelmax:** 877-986-9400 or dowelmax.com



## A BIT OF NEWS ...

We thought we'd share a couple of interesting items from the world of bits and blades.

### Infinity Cutting Tools

There's a new router-bit dealer on the block: Infinity Cutting Tools. The large (and growing) line of bits available from Infinity features steel bodies that are machined from solid-steel bars, not cast. C-4 micrograin carbide is then added to the anti-kickback designs, and a poly-tetrafluoroethylene (PTFE) coating is applied to help minimize any build-up of resin and pitch. They are priced to compete with other premium router bits on the market.

We've tried the bits (made in Florida) in the *Popular Woodworking* shop and have only good things to say. For more information on the entire Infinity line, call 877-USA-BITS (872-2487) or visit [infinitytools.com](http://infinitytools.com).

### Amazing Deals on Router Bits

If you've ever considered buying a big set of router bits, you should check out two sets from Woodline USA and MLCS. Each set offers a dizzying array of 66 bits (either ¼" or ½" shanks) for only \$190! Both sets include straight, dovetail, core-box, roundnose, flush-trim, mortising, V-groove, ogee, roundover, beading, rabbeting, chamfer and cove bits. And a wall-mountable case is included with each.

The Sam Maloof Signature Series Master Craftsman Collection is available from Woodline USA (800-472-6950 or [woodbits.com](http://woodbits.com)). The Millennium Router Bit Set is available from MLCS (800-533-9298 or [mlcswoodworking.com](http://mlcswoodworking.com)). While there are some bits you might rarely use, these are remarkably complete sets and the price will give you options you could never otherwise afford.

### TOOL RATINGS

Performance is rated on a one-to-five scale. You won't see a low rating ("one" or "two") because we don't publicize inferior tools. "Five" indicates the leader in the category. Five dollar signs indicates highest price in the category. Three indicates an average price. If you have tool questions, call me at 513-531-2690 ext. 1255, or e-mail me at [david.thiel@fwpubs.com](mailto:david.thiel@fwpubs.com). Or visit our web site at [popwood.com](http://popwood.com) to sign up for our free, e-mail newsletter.

— David Thiel, senior editor

# Forrest Blades

## Quality Blades for America's Craftsmen

Serious woodworkers demand perfection. That's why so many of them choose Forrest saw blades.

Forrest quality is legendary. Our proprietary manufacturing process, hand straightening, and unique grade of C-4 micrograin carbide give you smooth, quiet cuts without splintering, scratching, or tearouts. In fact, independent tests rate our blades as #1 for rip cuts and crosscuts.

Forrest saw blades are simply the best that money can buy. They're made in the USA by the same family-owned business that's been producing and sharpening them for over 55 years. And they're backed by a 30-day money back guarantee. It's no wonder that serious woodworkers give them such high praise!

*"Your blades are without question the best by miles, and I have tried them all."*  
Bob Jensen-Fridley, MN

*"These are the finest blades I have ever owned and you should be proud of your quality product."*  
Patrick T. Hankard-South Windsor, CT

*"[Forrest blades] cut true, with no vibration. I was a carpenter by trade for over 60 years and continue to be an active woodworker. So, I can say with confidence that Forrest blades are the best."*  
Carl Stude-Burbank, CA

The message is clear. If you're looking for quality, performance, and value, it pays to choose Forrest blades every time.

## Our Most Popular Blades:

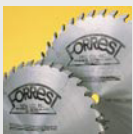

**Woodworker II** – This award-winning, all purpose blade is the finest of its type. It turns big jobs into easy-to-handle ones.



**Dado-King** – The world's finest multi-tooth dado set. It works effectively in all directions—with the grain or across it.



**Chop Master** – Produces perfect miters every time—with no bottom splinters. You get smooth edges on all types of wood.



**Woodworker I** – Great for table and radial saws. It trims and crosscuts all woods up to 2" and is ideal for plywood.



**Duraline Hi A/T** – Our best blade for birch and oak ply veneers. It also delivers a clean cut on melamine and vinyl over particle board.

Forrest blades come in a wide variety of sizes and are available for practically every application. Call or send for our complete list of products.

## Three Convenient Ways To Order

We back our blades with a 30-day money back guarantee. So, choose the method most convenient for you and order today:

- Visit one of our fine-quality dealers or retailers.
- Call us toll free at 1-800-733-7111. (In NJ, 973-473-5236) Ask about special discounts, free shipping on orders over \$275, and discounts for blade sharpening.
- Contact our internet store: [www.stores.yahoo.com/forrestman](http://www.stores.yahoo.com/forrestman)

# FORREST

The First Choice of Serious Woodworkers Since 1946



# 24-HOUR Workbench

Most woodworkers need a workbench that is sturdy, inexpensive and doesn't take a month of Sundays to build. This is that bench.

**W**henever we leave beginning woodworkers to work alone in the shop, it's a fair bet that when we return to check on them, they're working on the shop's floor.

We have at least five workbenches in our shop – not counting the assembly tables – but the new people always seem to prefer the wide expanse of the concrete floor more than the benches. Of course, I shouldn't talk. When I started woodworking I had my grandfather's fully outfitted bench. But my first few projects were built on the floor of our back porch, my assemblies propped up on a couple of 4x4s. I can't for the life of me remember why I chose the floor instead of the bench.

Since those early years, I've built a few workbenches. And I've been striving to make each one more versatile, solid, inexpensive and quick to build than the last. I think I've finally got it. To test my theory, Associate Editor Kara Gebhart and I built this bench with a \$180 budget and just 24 hours of working time in the shop.

That \$180 includes the wood, the vise and the hardware. And that 24 hours includes everything, too, even the two hours we spent picking out the wood and sawing it to rough length on a dolly in the parking lot of The Home Depot. (But once again, I was working on the ground. Oh, drat.)

by Christopher Schwarz & Kara Gebhart

Comments or questions? Contact Chris at 513-531-2690 ext. 1407 or [chris.schwarz@fupubs.com](mailto:chris.schwarz@fupubs.com). Contact Kara at 513-531-2690 ext. 1348 or [kara.gebhart@fupubs.com](mailto:kara.gebhart@fupubs.com).

The real beauty of this bench (besides getting you off the floor) is that it can be completed using tools you likely already have in your shop.

For this project, your must-have tools are a table saw, a drill press, a corded drill and some basic hand tools. If you have a jointer and planer, the project will go faster because you can easily dress your lumber to size and eliminate any bowing or warping. But don't be afraid to work with the lumber as it comes from the lumberyard. Just make sure you buy the straightest pieces you can.

## Start With the Rough Stuff

**Time: 0:00 to 5:06**

In a nutshell, here's how the bench goes together: The top is made of four pieces of Baltic birch plywood that are laminated together with a pine "skirt" glued around the edge. On the bench's pine base, the end rails are joined to the legs using pegged mortise-and-tenon joints. The end assemblies attach to the front and back rails using an unglued mortise-and-tenon joint with big bench bolts – it's quite similar to a bed in construction.

When we first went to the lumberyard, it seemed like a good idea to buy 4x4 posts for the legs. But when we got there (and later called around to other nearby lumberyards) we discovered that the only 4x4s avail-



Photo by Al Parrish



## BENCH OPTIONS

The beauty of this bench is that it can be used as a standalone workbench or as an outfeed table for your table saw. At 34" high, this bench is the same height as most cabinet saws on the market. And if you make the legs  $\frac{1}{2}$ " longer, the bench will be at the height of most contractor saws (check yours before you begin).

If you want a toolbox for this bench, pick up a copy of our August 2002 issue (you can buy a back issue at [popwood.com](http://popwood.com)). The toolbox under the bench in that issue is designed to fit perfectly under this bench, too. And the toolbox is built using one 4' x 8' sheet of  $\frac{3}{4}$ " plywood and one sheet of  $\frac{1}{2}$ " plywood.





Use whatever clamps are on hand to glue the top together. If you're low on clamps, you can use 5-gallon buckets of water (they are quite heavy) in the middle, the four cauls discussed in the article and C-clamps along the edges.

able in yellow pine were #2 common, which has more knots than the #1 pine (also sold as "prime" or "top choice" in some yards). If you can't get yellow pine where you live, you can just look for fir. (To find yellow pine in your area, visit [southernpine.com](http://southernpine.com).)

After picking through the mound of knotty 4x4s, we decided to instead make the legs by ripping a 2x8 and gluing up the legs to the thickness that we needed. It took longer to make the legs this way, but now they have almost no knots.

Crosscut and rip the parts you need for the base of the bench and the skirt that goes around the top. If you have a planer and jointer, dress your lumber. Now glue up and clamp the parts for the legs and get out your clamp collection and some buckets (yes, buckets) to glue up the top.

### Top-down Construction

**Time: 5:06 to 6:29**

I've built a few of these benches and have come up with a pretty easy way to make the top: Just sandwich all the plywood into a nearly 3"-thick slab. We glued it on one layer at a time to keep

things under control and to ensure we could eliminate all the gaps on the edges.

You're probably going to need at least four 8-ounce bottles of yellow glue for this part of the project, plus a scrap of plywood (1/4" x 4" x 7" worked for us) to spread the glue evenly. Squirt a sizable amount onto one piece of plywood and spread the adhesive until you've got a thin and even film. Place the plywood's mating piece on top and line up the edges. Now drive about a dozen #8 x 1 1/4" screws into the two pieces. Space the screws evenly across the face of the board, but you don't need to get scientific about it. The object is to pull the two pieces together without gaps.



The skirt pieces can be joined using finger joints, a miter or just wood screws. If you choose finger joints, your best bet is to lay out and cut the joint on one member and then use that joint to lay out your cut lines on its mate.

After 30 minutes of drying time, remove the screws and add another layer of glue, plywood and some more screws.

Because you don't want a bunch of screw holes staring at you every time you use the bench, you'll likely want to attach the final layer with clamps, clamping cauls and anything else heavy you have in your shop.

We used four cauls (a clamping aid) across the width of the top to put even more pressure in the middle. The cauls should be about 2" x 2" x 32". Plane or sand a 1/16" taper toward each end to give each caul a slight bow. When you clamp the bow against the top, this will put pressure in the middle of your slab.

Finally, use whatever other clamps you have to clamp the edges (C-clamps work well).

When all four layers are glued together, cut your top to its finished size using a circular saw and

a straight scrap of wood to guide it. Because the top is so thick, you'll have to cut from both faces, so lay out cutting lines with care.

### Skirt Will Test Your Skills

**Time: 6:29 to 11:49**

Now gather the skirt pieces and begin laying out the finger joints for the corners. These joints are mostly decorative. Butt joints or miters will do just as well (and save you some time). And if you want to make this process even easier, use 1/2"-thick material for the skirt, which is a whole lot easier to clamp in place because it is more flexible than some of the thicker material.

Here's how we suggest you cut the finger joints: First lay out the joints on the end pieces with just one tongue or finger sticking out. Each finger is 1 3/8" long and 1" wide. Cut the waste away using a hand saw or band saw and check the fit against your top. When it

## 24-HOUR WORKBENCH

NO.	ITEM	DIMENSIONS (INCHES)			MATERIAL	COMMENTS
		T	W	L		
❑ 1	Top*	3	24 1/4	58 1/4	Baltic birch plywood	
❑ 2	Top skirt, ends	1 3/8	3	27	Southern yellow pine	
❑ 2	Top skirt, front & back	1 3/8	3	61	Southern yellow pine	
❑ 4	Legs	3	3	31	Southern yellow pine	
❑ 4	End rails	1 3/8	3	23 1/2	Southern yellow pine	2" TBE
❑ 2	Front & back rails	1 3/8	7	40	Southern yellow pine	3/4" TBE
❑ 1	Vise jaw	2 3/4	6	15	Southern yellow pine	

\* The top is laminated using four layers of 3/4"-thick Baltic birch plywood.

TBE=Tenon, both ends.



fits perfectly, use these joints to lay out the mating joints on the long skirt pieces. Cut the notches on the long skirt pieces and check the fit of your joints. Tune them up using a chisel, a rabbet plane or a shoulder plane.

Now glue the skirt pieces to the top. Because each “ply” in plywood runs the opposite direction of the ply above it, there’s actually a fair amount of long grain on the edges of your top. This means the skirt will stay stuck just fine using only glue. Add as many clamps as you can. While that glue dries, start reading the directions for installing the vise, because that’s the next step.

The instructions that come with the Veritas vise are complete and easy to follow; it just takes some time to get everything moving smoothly. Before you begin, be sure your drill press’s table is square to the chuck – this will save you lots of frustration. Once you get your vise installed, place the top on a couple of sawhorses (you’ll need a friend’s help) and get ready to build the base.

### A Stout Base

**Time: 11:49 to 14:54**

The base of this bench is built with mortise-and-tenon joints. The two assembled ends are glued together and then pegged using

dowels. The ends are attached to the front and back rails using an unglued mortise-and-tenon joint plus bench bolts.

The first step is to make a practice mortise in a piece of scrap that you can use to size all your tenons. We made our mortises on a drill press using a  $\frac{3}{4}$ "-diameter Forstner bit and a fence. You can make really clean mortises this way. After you’ve made your test mortise, head to the table saw to make all of your tenons.

I make my tenons using a dado stack in my table saw. The fence determines the length of the tenon; the height of the dado blades determines the measurement of the

## SUPPLIES

### Lumber:

- 3 • 2 x 8 x 12' boards, preferably Southern yellow pine (if available in your area) or vertical-grade fir. We paid \$8.58 for each board (\$25.74 total).
- 2 • sheets of  $\frac{3}{4}$ " Baltic birch, Finnish birch or Appleply. This material comes in 60" x 60" sheets. Have the lumberyard rip them down the middle so you end up with four sheets of  $\frac{3}{4}$ " x 30" x 60". We paid \$27.93 per sheet – what a bargain (\$55.86 total).

### Hardware:

- 4 • 5" corner braces. We paid \$1.87 each (\$7.48 total).

### Lee Valley Tools

800-871-8158 or [leevalley.com](http://leevalley.com)

Prices do not include any sales tax or shipping.

- 1 • set of four Veritas special bench bolts #05G07.01, \$19.95
- 1 • large front vise #70G08.02, \$67.50
- 1 • vise handle #05G12.03, \$3.50

**Total price: \$180.03**

*Prices as of publication deadline.*

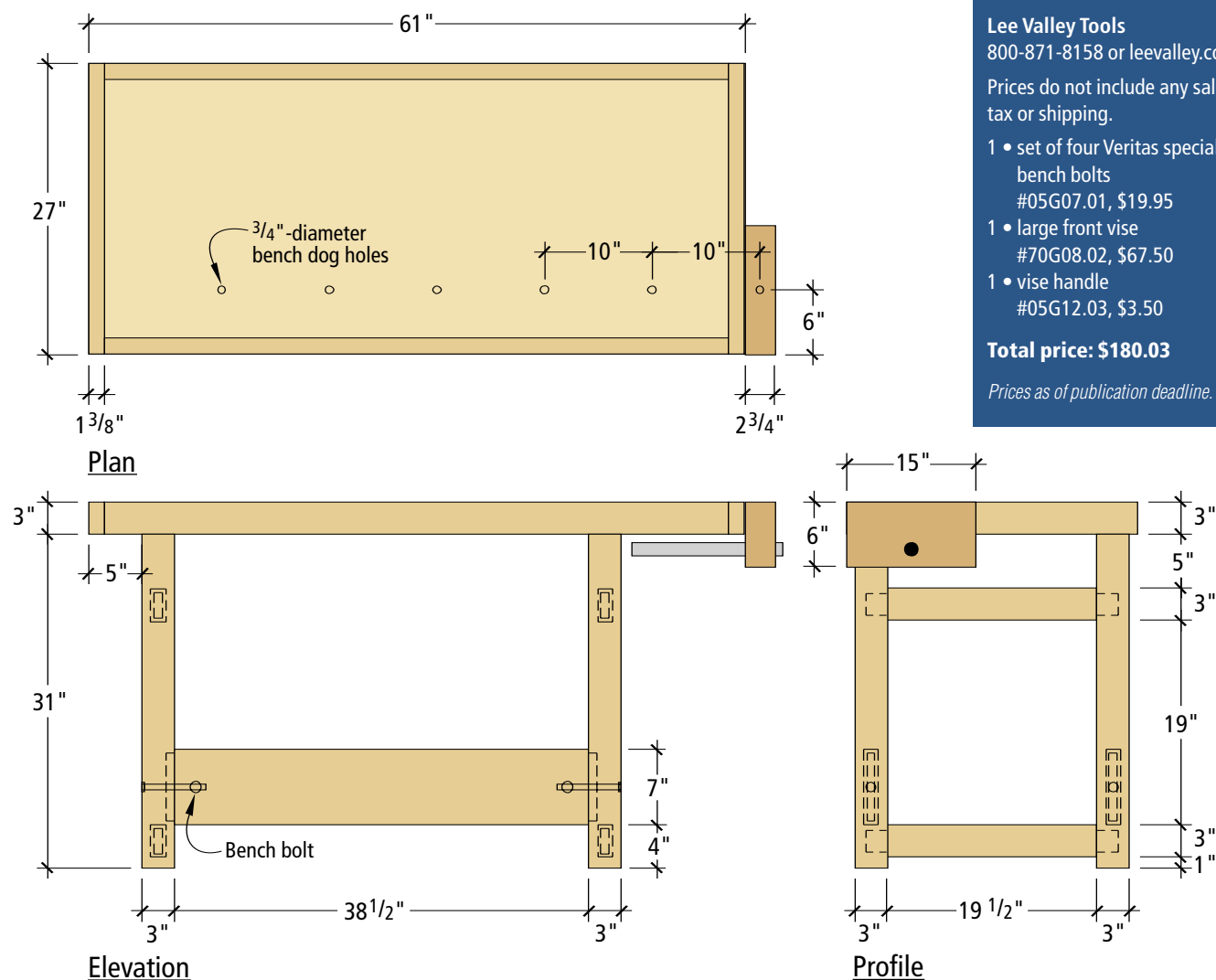

tenons' shoulders. Set the height of the dado stack to  $\frac{5}{16}$ " , cut a tenon on some scrap as shown in the photos and see if it fits your test mortise. If the fit is firm and smooth, cut all the tenons on the front, back and end rails.

Now use your tenons to lay out the locations of your mortises on the legs. Use the diagrams as a guide. Cut mortises using your drill press and get ready to install the bench bolts.

**Big Bad Bench Bolts**  
**Time: 14:54 to 18:59**

The set of bench bolts for this project set us back \$20, but they are worth it. There are less expensive alternatives to this specialty hardware, but none are as easy to put together.

You can begin installing the bench bolts by drilling a  $1\frac{1}{8}$ "-diameter x  $\frac{1}{2}$ "-deep counterbore in the legs that's centered on the location of the rail. Then drill a  $\frac{5}{8}$ "-diameter hole in the center of that counterbore that goes all the way through the leg into the mortise you cut earlier.

Now dry-assemble the ends plus the front and back rails and clamp everything together. Use a  $\frac{5}{8}$ " brad-point drill bit to mark the center of your hole on the end of each tenon.

Disassemble the bench and clamp the front rail to your top or in a vise. Use a doweling jig and a  $\frac{5}{8}$ " drill bit (as seen in the photo below) to continue boring the hole for the bench bolt. You'll need to drill about  $3\frac{3}{4}$ " into the

rail. Then repeat this process on the other tenons.

Now you need to drill a  $1\frac{1}{4}$ "-diameter hole that intersects the  $\frac{5}{8}$ " hole you just drilled in the rail. This  $1\frac{1}{4}$ "-diameter hole holds a special round nut that pulls everything together. To accurately locate where this  $1\frac{1}{4}$ " hole should be, I made a simple jig (shown in the photos) I picked up from another project. This works like a charm and I recommend you use one. Sometimes drill bits can wander – even when guided by a doweling jig – and this simple jig ensures success.

Plane or sand all your legs and rails, then assemble the bench's base. First glue the end rails between the legs. Glue and clamp that assembly. When it's dry, drill a  $\frac{3}{8}$ "-diameter hole through each joint that's about 2" deep. Then glue and hammer a peg through the tenons using  $2\frac{1}{8}$ "-long sections of  $\frac{3}{8}$ "-diameter dowel stock into each hole. Then install the

bench bolts and use a ratchet and socket to snug your bolts and bring everything together.

Now screw the 5" braces to the legs using the photo at right as a guide. Turn the top upside down on the sawhorses and place the assembled base in position. Screw it down.

**Dog Holes and Details**  
**Time: 18:59 to 23:02**

Dog holes on a bench are essential for clamping large panels, holding table legs and even clamping difficult-to-clamp assemblies. Most round dog holes are  $\frac{3}{4}$ " in diameter so they accept a wide range of commercial dogs.

We made our own dogs for this bench to keep us from blowing our \$180 budget. (If your budget isn't as strict, we recommend the Veritas brass Bench Pups. They cost \$14.95 for a pair. Ask for item #05G04.04. Contact Lee Valley at 800-871-8158 or leevalley.com.)

Our homemade dogs are made

The easiest way to make clean mortises using your drill press is to first drill a series of overlapping holes. Then go back and clean up the waste between these holes several times until the bit can slide left to right in the mortise without stopping. Then you only have to square up the ends with a chisel.



We cut our tenons using a dado stack. We like this method because it requires only one saw setup to make all the cuts on a tenon. First define the tenon's face cheeks and shoulders (above). Then you can define the edge cheeks and shoulders. Finally, check your work using the test mortise you cut earlier (right).



Once you've drilled the counterbore and the through-hole for the bench bolt, mark its location on the end of the tenon using a brad-point bit.

Drill a hole for the bench bolt using a doweling jig and a  $\frac{5}{8}$ "-diameter drill bit. It's a deep hole, so you might need an extra-long bit to do the job.



using 3"-long sections of  $\frac{3}{4}$ " dowel screwed to  $\frac{5}{8}$ " x  $1\frac{1}{2}$ " x  $1\frac{1}{2}$ " pieces of scrap hardwood.

First drill the dog hole in your tail vise's jaw using your drill press. While you have the vise jaw off the bench, go ahead and add the edge detail of your choice to the ends. We chose a traditional large bead. A chamfer would be quicker if you're pressed for time.

Now put the vise's jaw back on and lay out the locations of your dog holes in the top. They can be anywhere from 8" to 11" apart. You'll have to build a simple jig to cut the holes. It's made from three pieces of scrap and is shown in action in the photo at the far right.

We bored the dog holes using a  $\frac{3}{4}$ " auger bit in a corded drill. Use a low speed on your drill for this operation because you need buckets of torque.

Now chamfer the rim of each dog hole; this prevents the grain from ripping up when you pull

the occasionally stubborn dog from its hole (bad dog!). You can just use a chamfer bit in your plunge router to make this cut. Or you can simply ease the rims using some coarse sandpaper.

We sanded the top by using #120-grit sandpaper in a random-orbit sander and called it a day. Break all the sharp edges using #120-grit sandpaper. You don't need a fancy finish on this bench – just something to protect it from spills and scrapes. We took some off-the-shelf satin polyurethane, thinned it down to three parts poly and one part mineral spirits and ragged on two coats. Allow the finish to dry at least four hours between coats. (No, the four hours of drying time isn't included in our total time.)

Then we turned the stopwatch off and checked our time: 23 hours and 2 minutes. We had just enough time left to sweep the floor in case someone else needed to work down there. **PW**



Installing the brackets that secure the top to the base is simple with this trick. Lay a scrap board across the legs and clamp the bracket to it. Now screw the bracket to the leg.



Here you can see our dog-hole drilling jig in action. There are two  $\frac{3}{4}$ " holes in the plywood base: one for the bit and the other to allow us to see the layout marks on the benchtop.

To accurately position the hole for the brass nut shown in the photo, build a simple jig like the one shown here using  $\frac{5}{8}$ " dowel, a scrap of wood and a nail. The nail is located where you want the center of the brass nut to go. Insert the dowel into the hole in the rail and tap the nail. Then just drill a  $1\frac{1}{4}$ "-diameter hole there and your joint will go together with ease.

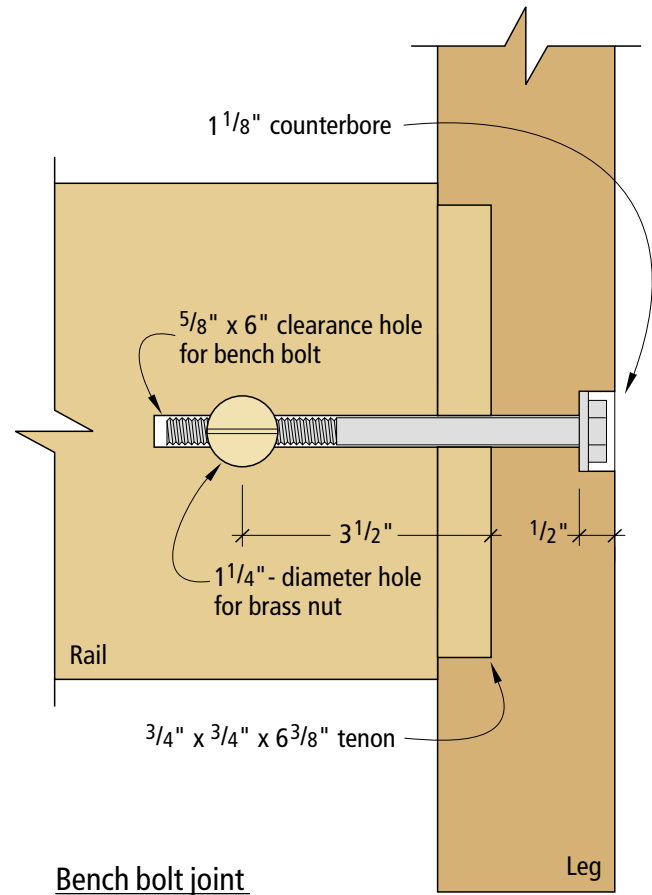
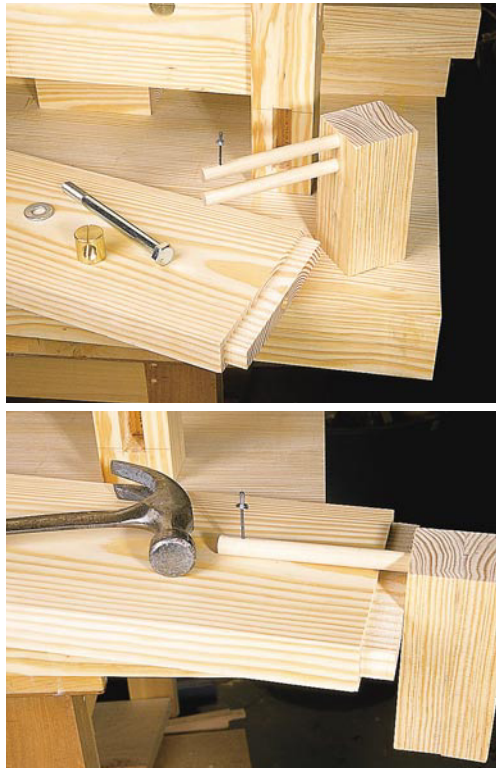

**Bench bolt joint**

# Shaker Drop-leaf Table



This unusual splayed-leg table will offer you new challenges (angled tenons) plus a lesson on rule joints.

Just about every woodworker will agree that any project with angles other than 90° makes things more challenging. This handsome Shaker-style table with splayed, or angled, legs is no exception. But don't be put off, because it's not as difficult as it looks.

First, keep in mind that virtually all the angles are 4°. Simple enough. As for making the leg-to-apron mortise-and-tenon joint, breathe easy because it's almost as simple as making 90° joints.

Speaking of mortise-and-tenon joints, there's a pull-out advertising section in the middle of this issue that shows you how to make this sturdy and essential joint with a shopmade router jig and a dado stack.

by Steve Shanesy

Comments or questions? Contact Steve at 513-531-2690 ext. 1238 or [steve.shanesy@fwpubs.com](mailto:steve.shanesy@fwpubs.com).



Clamp a V-block to a miter saw and bevel the blade to the right  $5\frac{1}{2}^\circ$ . With what will be the inside corner of the leg facing up, make the cut for the top of the leg. Turn the leg  $180^\circ$  to cut the bottom end to final length.

### All the Angles

Before we start, here's a list of the angle cuts: All apron ends and long edges, including the top edge of the drop-leaf support arm; both ends of the legs; and the cleats for attaching the top. That's it!

There's not a lot of material required for this project, so go ahead and mill the pieces to size, leaving some length for trimming later. Be sure you have some extra pieces to use for setups. I used 1"-thick material for the aprons, but  $\frac{3}{4}$ " works equally well (just change the tenon thickness to  $\frac{3}{8}$ ").

Before preparing the stock for the legs, see "Legs: It's All in the Growth Rings" article on page 46. I used this technique with excellent results. Keep the leg stock square (don't taper it until after the mortises are cut) and, when cutting to length, cut the  $5\frac{1}{2}^\circ$  angle on the ends.

Use a V-block to simplify the angle cutting, as shown in the photo above. To determine which corner is up, first mark the mortise locations on the legs. To cut the angle, bevel the miter saw  $5\frac{1}{2}^\circ$  to the right and position the leg to the left of the blade with its inside corner (where you will cut the mortises) facing up. Make your cut. To cut to final length, measure and turn the leg so the inside

corner is down. Save a short angled scrap from the leg – it will be useful when mortising.

Lay out the mortise locations on a test piece with the angle cut on the top edge. I used an  $\frac{1}{8}$ " set-back for the apron to the leg.

The mortise starts 1" down and is  $\frac{3}{4}$ " long. The depth is  $\frac{3}{4}$ ". Now turn to the poster section in the center of this issue and follow the mortising steps.

After mortising, complete the legs by cutting tapers on their two inside faces (the faces with mortises). The taper begins 1" down from the bottom edge of the apron. Mark this point. The leg tapers to  $\frac{3}{4}$ " x  $\frac{3}{4}$ " at the floor – which is one-half its thickness. Mark your taper lines on all four legs. Cut the tapers on the band saw wide of the line and clean up the cut using a hand plane or jointer. Except for sanding, the legs are now complete.

### Angled Tenons

Next work on the aprons. Cut them to length as shown in the illustration on page 45 – don't forget the  $4^\circ$  angle on the ends.

Before ripping the angles on the apron, determine which face will be outside and mark it. When done, the longer edge of the apron

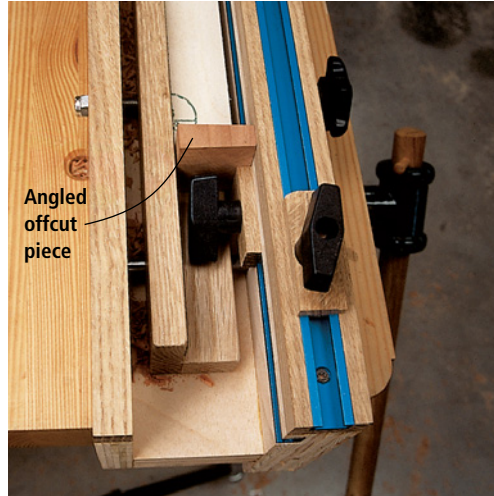

Use an angled offcut piece from the leg when setting the stop block in the mortising jig. Set it in place so the top of the leg is square. By doing so, the mortise will be in the same location on both faces of the leg.

is the bottom edge. To cut the angles, bevel the table saw blade  $4^\circ$ . Now set the fence and place the apron on the saw so the less-acute angle will be the outside. (This depends on whether your saw tilts right or left.) Reset the fence and cut the complementary angle on the bottom edge.

To form the tenons, refer to the poster for cutting the wider face cheeks. Because of the angled cut on the apron ends, the edge cheeks and shoulders are best cut by hand.

When the tenons are done, notch each long apron for its drop-leaf support arm. Following the

## INSTALLING DROP-LEAF TABLE HINGES

Drop-leaf hinge installation isn't intuitive. What seems normal – just placing the hinge barrel where the leaf and top meet, like a door to a stile – is totally wrong. Another wrong assumption is that the correct depth to set the hinges is simply to make them flush with the underside surface.

As with all hinges, the location of the pivot point is the ultimate concern. With the drop-leaf hinge, the pivot point, which is the center of the pin, must be centered on the radius of the matching profiles. In my case, the  $\frac{1}{2}$ " radius of the rule joint requires the hinge pin to be  $\frac{1}{2}$ " down from the top of the radius and  $\frac{1}{2}$ " in from the side.

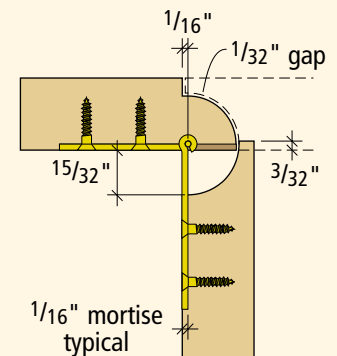
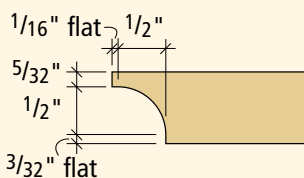
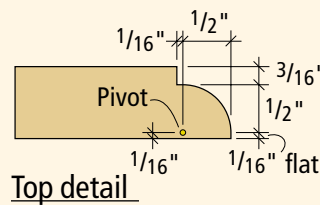

Rout the mating profile for the leaves using a cove bit. The bit height should leave a  $\frac{5}{32}$ " flat to match the mating profile's bead.



When both rule joint profiles are correct they nest together with the top surfaces flush and a  $\frac{1}{32}$ " gap between the profiles.

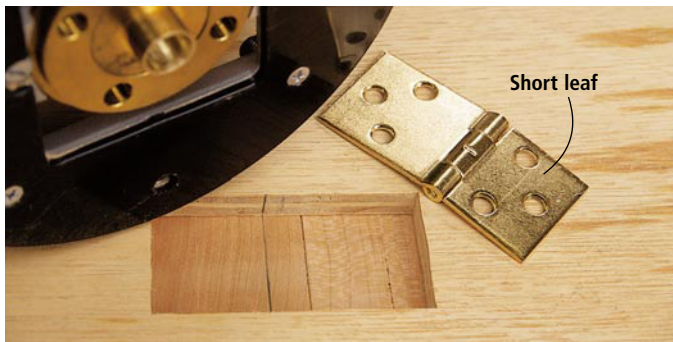

Rout the leaf-hinge mortise using a template and guide bushing. Note the unequal lengths of hinge leaves. The short leaf goes on the tabletop side. Also, use the pencil line on the table surface to align the template. The pencil line on the template edges serve as the center point of the hinge pin.

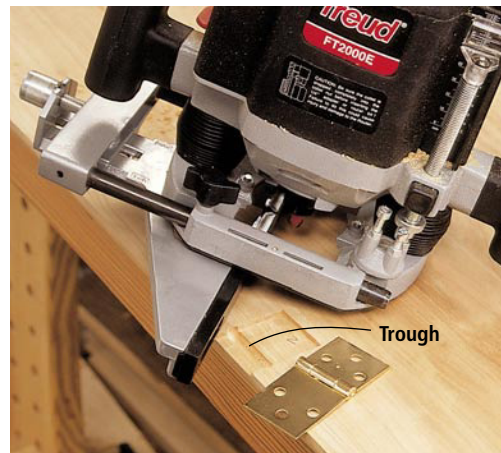

A shallow trough must be made to accommodate the hinge barrel. Use a fluting bit and an edge guide.

drawings on page 45, use a hand saw or band saw to make the cutouts. The cut along the length of the notch is square to the face. When making the support pieces, the long bottom edge is square but the top edge is at  $4^\circ$  to match the apron edge. Attach the supports after assembly by screwing them in place, leaving them loose enough to swivel.

### Base and Top Assembly

With the work on the legs and aprons complete, dry-fit the table base. After making any adjustments, glue it up. I made clamping cauls with one face at  $4^\circ$  to position the clamps square across the joint. I glued and clamped the base in two operations to avoid the typical panic associated with gluing it up all at once.

Next, glue the stock you need for the top and drop-leaves. Take

a moment to organize the wood for the best grain pattern and color match. After the glue dries, trim the pieces to their final sizes.

### The Rules of Rule Joints

The traditional drop-leaf table uses a rule joint at the transition between the fixed top and the leaf. It provides an attractive appearance when open or closed. Making the matching inside/outside radius profiles on the leaves and top is not difficult, but properly locating the drop-leaf hinge on the mating parts requires a bit of knowledge and careful set-up (see "Installing Drop-leaf Table Hinges" on page 43).

The edge profiles on the table parts can be made using a hand-held router or a router table. I opted for the router table because it allows for more control.

Some router-bit manufactur-

ers offer matched bit sets to make the mating parts. These sets usually consist of a  $\frac{1}{2}$ "-radius bit and a  $\frac{1}{2}$ "-cove bit, each with a bearing guide. If you have one or both bits, the set isn't necessary.

Cut the profile on the table edge first. It has a  $\frac{1}{2}$ "-radius with a  $\frac{3}{16}$ " bead on top. Cut the profile in two passes so you don't tax your router. Make the same cut on a scrap piece, too. Next, install the cove bit and mill the mat-

ing leaf profile to the dimensions given in the drawing on page 43.

Now turn your attention to the drop-leaf hinges. Before you begin cutting the mortise for the hinges, remember this: Your hinge may be different so base your measurements on the hinges you use.

Place the tabletop and leaves together and upside down on your workbench and gently clamp the three pieces together. Now measure in 6" from the edge along the

## SHAKER DROP-LEAF TABLE

NO.	ITEM	DIMENSIONS (INCHES)			MATERIAL
		T	W	L	
4	Legs	1½	1½	28¼*	Cherry
2	Aprons	1	5	26¾**	Cherry
2	Aprons	1	5	9⅞**	Cherry
1	Top	¾	14¼	36	Cherry
2	Leaves	¾	7½	36	Cherry
2	Leaf supports	1	1½	12½	Cherry

\* Dimension is slightly bigger than finished size.

\*\*Apron lengths from longest point at shoulder and includes  $\frac{3}{4}$ " tenons.

rule joint to determine the general location of each hinge.

From the joint edges, make a line  $\frac{1}{2}$ " back on the tabletop side. This is the pin location on one axis. Repeat this procedure on one axis. Repeat this procedure for all four hinge locations.

Now set up a router with a  $\frac{1}{2}$ " straight bit and guide bushing (mine had a  $\frac{5}{8}$ " outside diameter). Make a template using  $\frac{1}{2}$ " plywood with a cutout sized to the hinge and the bushing diameter. In my case, this is the hinge width or length plus  $\frac{1}{8}$ ". After making the cutout, scribe a line on each side edge of the template opening in the exact lo-

cation of the hinge-pin center. This is not centered because the hinge leaves are different lengths. The longer leaf is on the leaf side.

Now set the router's depth of cut to include the template thickness plus the required depth for the center point of the hinge pin. It should be about  $\frac{3}{32}$ ".

Using the scrap test pieces for the rule-joint profile setup, test the template by routing the hinge-leaf mortise. Arrange the template so the lines scribed on the template align with the  $\frac{1}{2}$ " pencil line you marked earlier.

Before installing the hinge in the test pieces, remove some ma-

terial to accommodate the hinge barrel. Install a  $\frac{1}{4}$ " fluting bit in your router along with an edge guide. Remove the clamp and the table leaves. Adjust the edge guide so the bit aligns with the hinge barrel location. Adjust the depth of cut to accommodate the hinge barrel. Now make the relief cut for the hinge barrel.

Install the hinge in your test pieces and check out the movement. There should be no binding, it should be fully closed when on the same plane and it should have a small gap when at  $90^\circ$ . When satisfied, rout the mortises in the three top pieces.

Now install the hinges. Leave one screw out and test the action. If good, insert that final screw.

To attach the tabletop to the

base, make cleats that attach the apron sides and top. The top edge of the cleats must have the  $4^\circ$  angle to match the top apron edge.

To finish the table, I first sanded through progressive grits from #120 to #220 grit.

For a clear finish, I used one of my favorite "recipes" when I don't want a heavy film finish. My concoction calls for equal amounts of paint thinner, boiled linseed oil and oil-based varnish.

This liquid is thin enough to rag on and wipe off, and after a couple coats it offers reasonable surface protection compared to an oil finish alone. The finish is especially effective on cherry because the linseed oil accelerates the natural darkening and aging of the wood. **PW**

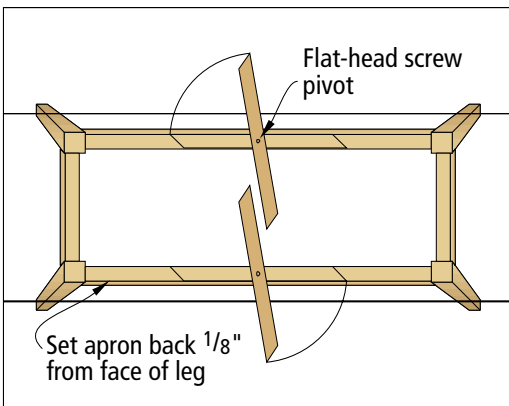

Plan-top removed

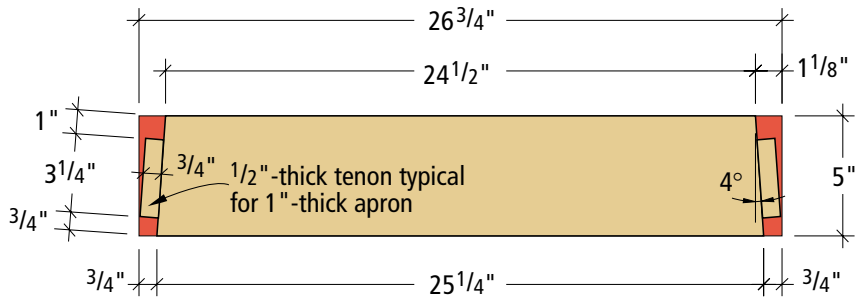

Long apron

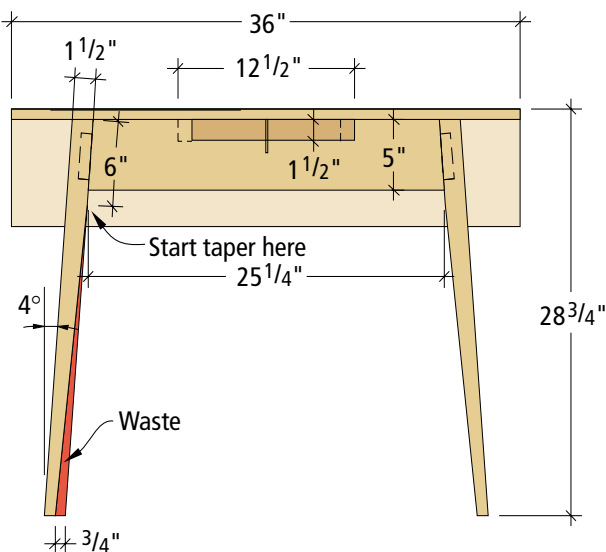

Elevation

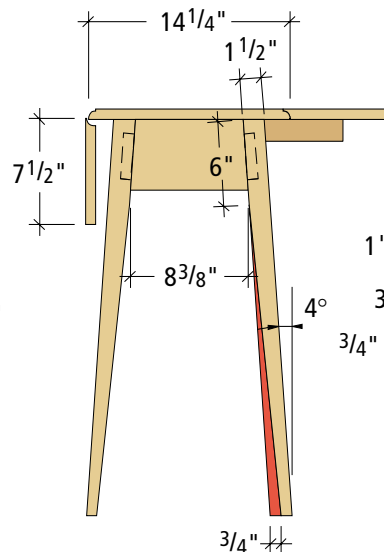

Profile

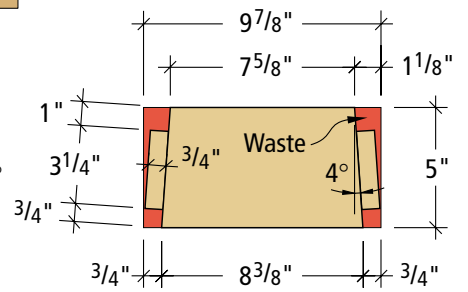

Short apron



# Legs: *It's all in the Growth Rings*

Pay attention to the end grain for great-looking legs.

**M**aking tapered legs for a table is a bit more complicated than most woodworkers imagine.

Years ago when I built my first Shaker occasional table I cut the legs from a single slab of nice-looking 8/4 cherry. Everything looked great until I applied the top-coat finish.

Something was wrong, but at first I couldn't put my finger on it. Two of the legs looked good, but the others stuck out like a sore thumb. The front and back faces of the legs looked different than the sides.

Little did I know that I had just gotten a painful lesson in the difference between flat-sawn and quartersawn figure.

## The End Tells the Story

To understand this important point without having to ruin a nice set of legs yourself, take a look at the photos at right.

by Christopher Schwarz

Comments or questions? Contact Chris at 513-531-2690 ext. 1407 or [chris.schwarz@fwpubs.com](mailto:chris.schwarz@fwpubs.com).



Quartersawn leg



Flatsawn leg



Grain looks the same from all four sides

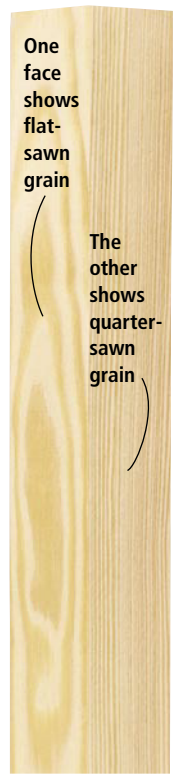

One face shows flat-sawn grain

The other shows quarter-sawn grain





**1** You want the grain in your legs as straight as possible. Mark a line on your lumber that is parallel to the grain and close to the edge. Band saw to that line.

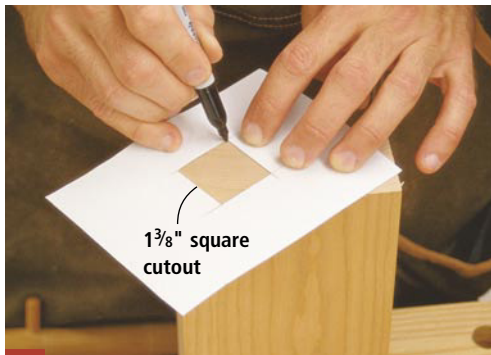

**2** A template helps you visualize the correct growth-ring orientation for the legs. Turn the template until the growth rings run from corner to corner. Mark that on the end grain.

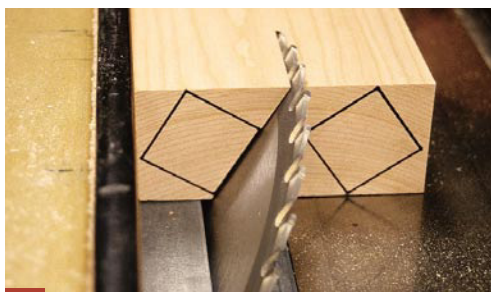

**3** Set your table saw's blade to match the angle marked on your wood. Rip this edge off the leg.



**4** Now square up the leg blank on your jointer and table saw.

The key to understanding this puzzle is in the end grain of your legs. If you look at the photos of the flatsawn leg, the growth rings run left-to-right through the leg. On two sides of the leg, the tree's growth rings are parallel to the face – known as flatsawn or tangential grain. On the other two sides of that leg, the growth rings intersect the face of the leg at a 90° angle – known as quarter-sawn or radial grain.

Flatsawn grain and quarter-sawn grain look quite different in many species, especially in those where the earlywood and latewood are distinct. These legs look odd because we expect the four surfaces to appear the same. After all, the surfaces are about the same size and are from the same piece of wood. But they don't look the same, so it's distracting, even glaring. It looks even worse with a finish on it.

### Think Bastard Grain

The trick to getting around this problem is either to select your lumber carefully before cutting or to cut it in a special way.

In essence, you want the growth rings to travel at a 45° angle from corner to corner (or an angle that's close to that). If you study the photos you'll see why this works. No matter which face of the leg you look at, the growth rings intersect that face at a 45° angle, so the leg looks and reflects light the same no matter where you are standing in the room – pretty clever.

If you select the boards for your project's legs carefully before construction, you can purchase wood with the growth rings at about a 45° angle to the faces of your board. Sometimes called "bastard grain," you'll usually find this growth-ring pattern near the long edges of wide boards.

If you can't find this growth pattern in the wood at the lumberyard, you can purchase stock that is thicker than what you need and band saw to create bastard grain. It's easier than you think.

### Finding Your Legs

The first step is to trim your board so the face grain is as straight as possible – angled grain looks odd on a leg. Look at the face of your board and use a yardstick to mark a straight line that is parallel to the grain lines and near an edge of your board. Band saw to that line, clean up the cut on the jointer and rip the board as wide as possible. Your grain is now straight.

To help visualize the growth-ring pattern on the end grain, make a cardboard template that has a hole cut in it that matches the thickness and width of your legs, plus 1/8" on all four sides.

The legs for the table at left are 1 1/8" square, so my template had a 1 3/8"-square cutout. Place the template on the end grain and rotate it until the growth rings run from corner to corner. With a magic marker, mark this shape on the end.

Use a sliding T-bevel to measure this angle and then set your table saw's blade to the same angle, as shown above. Rip the board right up to the line you marked on the end grain. Now square up the stock to this line using your jointer and table saw. Finally, use your planer to reduce the leg to its finished thickness.

There is one slight disadvantage to legs with bastard grain: If they have much more drying to do, the legs will distort into somewhat of a diamond shape (if you were looking at them on end) as they dry. This can open your joints, so use dry wood. **PW**

# BIG VALUE

## Hickory Bonus Time!



**1/2" Shank  
24-Piece  
Carbide  
Router Bit Set  
RBK1031  
159-829**



**1/4" Shank  
24-Piece  
Carbide  
Router Bit Set  
RBK1030  
624-651**



**1/4" Shank  
12-Piece  
Carbide  
Router Bit  
Set  
RBK1029  
645-679**



**16-Piece  
High Speed  
Steel  
Forstner Bit  
Set  
FBS1016  
803-713**

**Buy a Hickory Woodworking set  
and get a free Home Depot gift card**

**Hickory Woodworking Carbide Router Bits:**

- Machined, not cast, for a stronger, safer bit
- Precision sharpened virgin carbide

Questions? Call 1-800-828-9000  
or visit [www.oldham-usa.com](http://www.oldham-usa.com).

**Buy Quality • Do More Projects  
Have Fun Woodworking!**

**FREE \$5 to \$15  
Value Gift Card**

With purchase of any Hickory  
Woodworking set(s) shown in  
this ad. See store for details.



Offer valid only at The Home Depot Nov 1, 2003 - Jan. 31, 2004

CIRCLE NO. 136 ON FREE INFORMATION CARD.

# WOODWORKING ESSENTIALS

BY NICK ENGLER

CHAPTER

## 3

# The Router Table

After you've worked with a hand-held router for some time, you'll find that many operations are easier and safer if you pass the workpiece across the bit instead of the other way around. This is especially true when routing small pieces or when making many identical cuts. For these tasks,

holding the tool stationary by mounting it in a table or a jig is a good idea.

There are two common ways to mount a router: vertically beneath the work or horizontally beside the work, as shown in the illustration on the next page. Each position offers unique advantages, and there are a number of

tools and jigs available that will hold the router in each position. You can purchase or make many different router-mounting jigs and accessories, but the most versatile is the router table. This device holds the router vertically beneath the work, with the bit protruding up through a hole in the table – all you have to do is rest your workpiece on the table's top and guide it over the bit.

There are many commercial router tables on the market, as well as several you can make from a kit. You can make your own from scratch pretty easily. A homemade router table may be a better option in the long run for a number of reasons:

- You can build it to fit whatever kind of router you already own.
- You can make it suit whatever available space you have in your shop.



### PRO TIP:

#### Rout End-grain Edges First To Avoid Any Tear-out

When routing profiles on four edges of a rectangular or square piece, start with an end-grain edge first. If the end of the cut tears out, the following pass on the long-grain edge will most likely remove the torn-out corner.

# TIPS & TRICKS

## PRO TIP:

### Titanium-coated Bits Don't Burn Wood When Sharp

Manufacturers sometimes coat the cutting edges of large, carbide-tipped router bits with a gold-colored titanium alloy and claim the bits can be used safely without reducing the routing speed. This is true to an extent. Titanium-coated carbide can be honed to a much sharper edge than the uncoated variety. While the cutting edges remain razor-sharp, the bit will cut cleanly at high speeds. But as soon as the edges dull or load up with pitch, the bit will burn the wood.

## GREAT TIP:

### Dust Collector Keeps Table's Mess to a Minimum

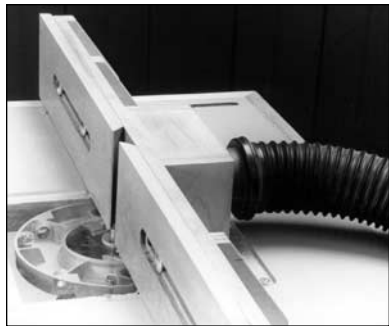

If possible, make sure your router table has a dust collector to minimize airborne dust as you work. On the table seen here, the collector is part of the fence.

## GREAT TRICK:

### Mount a Power Switch Closer to Table's Front

When a router is mounted in a table, it might be hard to reach the power switch. To solve this problem, mount a combination switch/outlet near the front of the table and wire it to control the power to the outlet. Plug your router into the outlet and use the switch to turn it on and off.

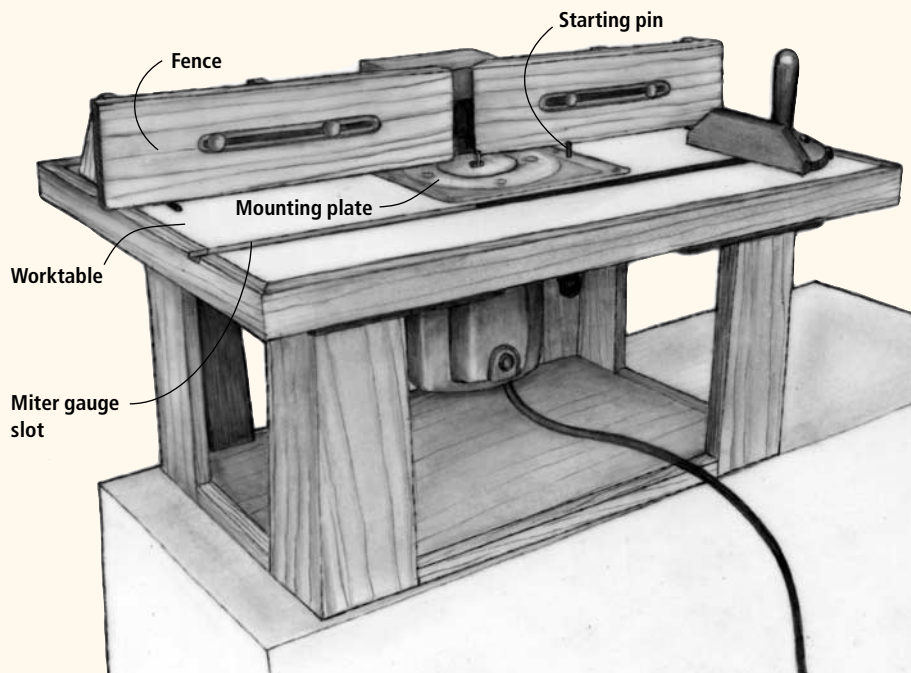

Illustrations by Mary Jane Favorite

• If you don't have room for a stand-alone table, you can customize other fixtures already in your shop to hold a router. A workbench, a table saw or a radial-arm saw all can pull double-duty as a router table.

*(Editor's Note: We provided construction plans for a router table in "Router Table-Mate" in our June 2001 issue. You can purchase the back issue by calling 800-258-0929 or online at [popwood.com](http://popwood.com).)*

## What Router is Best with a Table?

Choosing which type of router to use in a router table has been the subject of debate for many years. When the plunge router first entered the marketplace, it quickly became the router of choice for table use, offering more precise height adjustment than fixed-base routers.

One problem that arose was when the return spring on plunge routers pushed against the height adjustment, making it a difficult process. It didn't take long for woodworkers to remove the spring from their plunge routers to make the adjustment easier. Manufacturers recently have addressed that problem themselves by offering plunge routers that enable users to "defeat" the return spring.

Another difficulty router tables presented was the need to reach under the table to make height adjustments, change bits and actually turn the router

on and off. This led to removable plates in the tabletops to which the routers were attached. Rather than crawling under the table, the router and plate could be lifted free from above the table. These plates soon became even more helpful with the addition of built-in

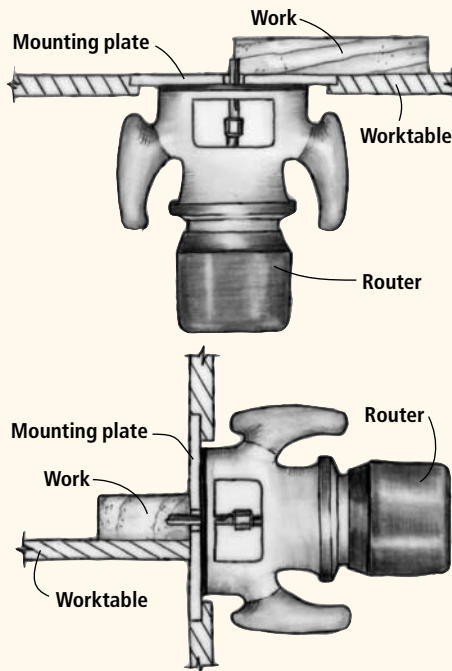

There are two common ways to mount a portable router and hold it stationary. You can mount it vertically under the work (top) or horizontally beside the work (bottom).

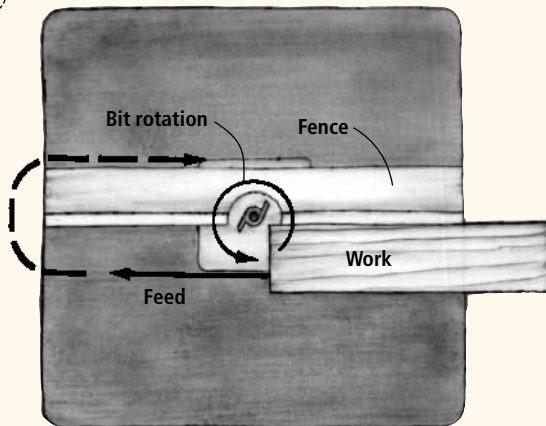

When a router is vertical under a table, the bit spins counterclockwise when viewed from above. Whether cutting the edge or interior of a workpiece, feed clockwise around the fence.

height adjustment. The router-lift plates make it possible to fine-adjust the height of a more-affordable fixed-base router from above the table, providing the best of both worlds.

Some of the newest fixed-base and plunge routers now offer built-in, through-the-base height adjustment. This makes the router lifts obsolete, though they're still the best option for older (as well as many of the newer and less-expensive) router models.

This brings us back to the question of what router to use in your table. A 1½- to 2-horsepower router can be used successfully in a table, but it will limit you to small- or medium-diameter bits. In general, it makes more sense to use a 2½- to 3-hp router in a table to maximize the benefits of the table.

The other strong recommendation is to outfit your router table with a variable-speed router. Because your table will support a larger-motor router, you can successfully use large-diameter bits. To get the best performance from these bits, they should be run at slower speeds, so a variable-speed router will give you optimum performance in your table, whether using smaller grooving bits or panel-raising bits for making doors.

That said, with the variety of table-friendly routers and router lifts available, it's impossible to recommend either a plunge or a fixed-base router as best for use in a table. You'll need to determine what your budget will allow and take

into consideration what routers you already own. With all the choices currently available, there's no reason you shouldn't be able to buy or build a router table that allows you to adjust and operate the router from above the table surface. It's up to you to choose how you assemble the hardware.

When adjusting the position of a router table fence, loosen the clamps at both ends of the fence and slide it forward or back. To make fine adjustments, tighten just one clamp and move the loose end of the fence.

### A Closer Look at Router Lifts

Router lifts are available in a number of varying designs, ranging from a retrofit kit to replace the spring in a plunge router to heavy-duty mounting platforms that include the table plate. Prices range from \$100 to \$400, so you should know what you're getting into before you spend any money.

Ultimately, the router lift should adequately support the router underneath the table without any concern of deflection or slipping. Deflection will cause the bit you are using to deviate from a 90° angle to the table, ruining the cut. The lift also should adjust the height smoothly in measurable and repeatable increments, and not interfere with the table surface. Most lifts that are on the

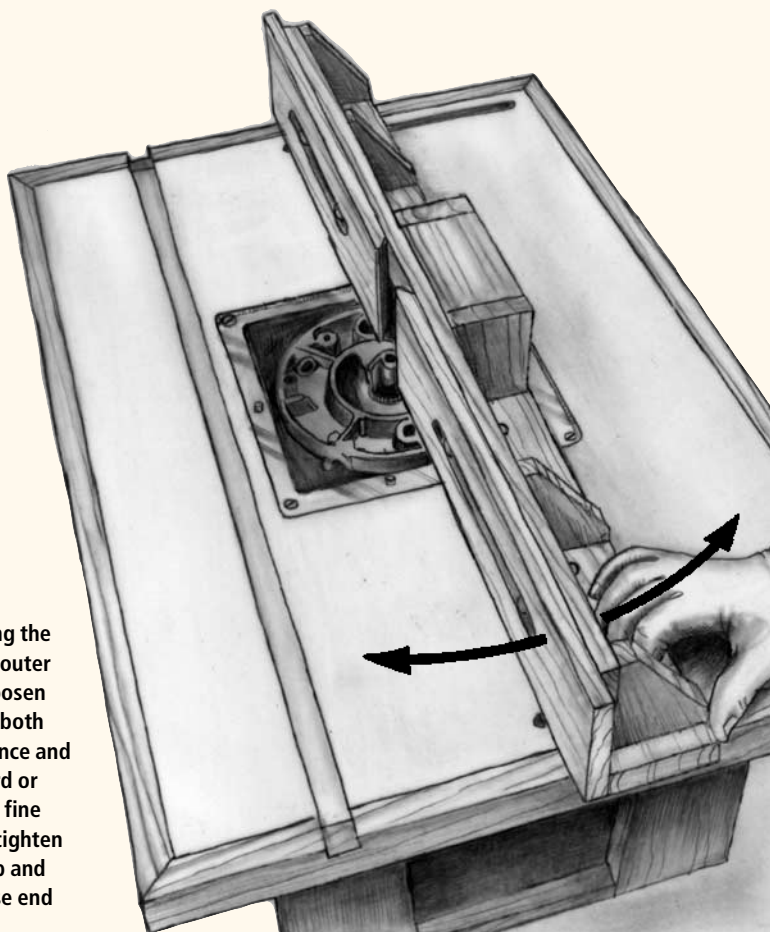

market are designed for use with fixed-base routers, which is fine, but you should choose a router with variable-speed control to take maximum advantage of the larger motor and available larger-diameter bits.

Some lifts also will allow you to change bits from above the table. These lifts raise the router high enough through the tabletop (while not running) to use both wrenches (or one wrench and a shaft lock). This is a great feature and highly recommended.

### Using the Router Table

When using a router in a router table, you will need to pay extra attention to the tool's feed direction. When your router is mounted upside down under a table, the bit spins counterclockwise (as viewed from above). Whether you are cutting the edge or the interior of a workpiece, imagine that you are feeding it clockwise around the fence – right to left as you face the fence.

The rotation will help keep the board pressed against the fence, making it safer to make the cut. When using a fence,

# TIPS & TRICKS

## **GREAT TRICK:** **Scrap Piece Helps when Routing Narrow Work**



When routing the end of a narrow workpiece on a router table, use a large square scrap to guide it along the fence. The scrap not only holds the work perpendicular to the fence, it also backs up the wood so it won't tear out.

## **GREAT TIP:** **Keep Your Hands Away With Small Workpieces**

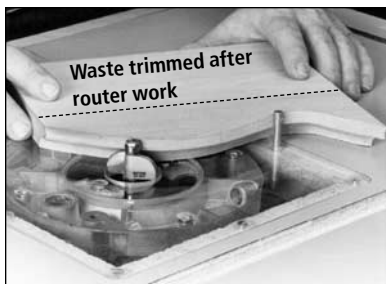

If a workpiece is very small, your hands may come too close to the router bit as you rout it. In this case, you have two choices – you can rout the work with a portable router using a commercially available foam rubber “routing pad” to hold the work, or you can rout a portion of a larger workpiece and cut a small piece from it, as seen above.

## **GREAT TIP:** **Slide Smoothly with Wax**

To help the table slide more smoothly, wax and buff the table surface, the fence faces, the miter gauge bars and the grooves for any miter fixtures.

you also need to check that the router is properly aligned and adjusted in the table. There are two things you need to check – the depth of cut (the distance the bit protrudes past the mounting plate) and the position of the fence.

Other things to remember when using a router table with a fence include:

- Keep the workpiece pressed firmly against the fence to ensure you get as straight a cut as possible.
- Feed the work slowly and steadily – do not pause, if you can help it.

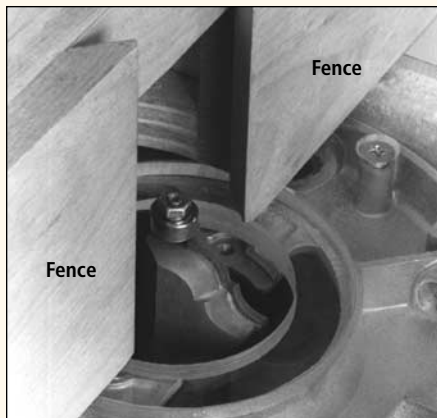

When properly used, a fence guides the work and also protects you from the bit. Even when using a bit with a bearing guide, align the fence faces even with the front edge of the bearing and adjust the fence gap as tightly against the bit as possible.

- Let the fence surround the unused portion of the bit.

- Whenever practical, use featherboards, push sticks and push shoes to guide the work along the fence.

A router table also can be used without a fence. In these cases, a starting pin and a bit with a bearing or a template guide attached is used. This operation is similar to using a hand-held router with a similarly guided bit, but the table operation makes it safer and easier to use larger-profile bits.

The starting pin provides an extra bearing point to allow you to rest against two points while routing, adding an extra level of safety. When using the router table in this setup it's even more important to maintain proper safety and hand clearance from the exposed bit.

## **Doubles as a Jointer**

Speaking of fences, it would be a large oversight not to mention using a router table as an edge-jointer. Some commercially available router-table fences give you the option to adjust the face of the outfeed table forward slightly (by as much as  $\frac{1}{8}$ " ) to offset the fences.

With a straight router bit aligned tangentially to the face of the outfeed table, you can run wood across the fence and straighten or thin edges just as you would on a jointer.

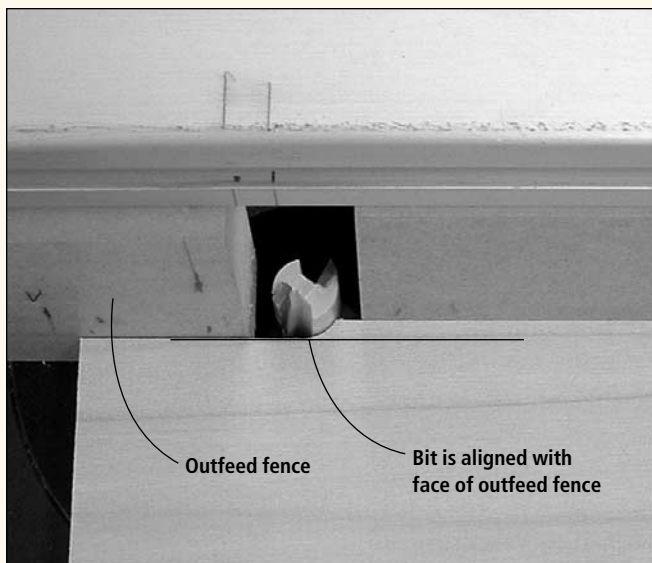

By offsetting the outfeed fence (moving it forward  $\frac{1}{16}$ " or  $\frac{1}{8}$ " ), a router table can be used as an efficient edge jointer. The face of the outfeed fence is aligned with the furthest point of the straight bit and, as the wood passes the bit, the outfeed fence supports the cut.

# A Stacked Dado Set With No Shims Needed?



**SD608**  
Dial-A-Width Dado Set

## Introducing Freud's New Dial-A-Width Stacked Dado Set



**1** Loosen



**2** Turn The Dial



**3** Tighten

**NO SHIMS  
NEEDED!  
JUST DIAL  
IT!**

U.S. Patent No. 5,368,079

Choose Freud's Dial-A-Width Stacked Dado Set, which is a must for fast, easy, and accurate flat-bottom dado cuts.

### No More Shims

For a perfect fit every time, all you need to do is dial. Freud's SD608 Dial-A-Width Dado set performs like an ordinary stacked dado set, but the shims have been replaced with a patented dial system, which allows you to adjust the width via an exclusive dial hub capable of micro adjustments. Each "click" of the dial adjusts the blade by .004"—that's thinner than a sheet of paper. The adjustable width range for the dial is 1/4" to 29/32".

### Easy and Accurate

Freud's innovative adjustable-hub design not only eliminates the need for shims, but allows you to fine tune the width of the dado without ever removing the dado cutter from your table saw. No more wasted time making adjustments and re-adjustments. A simple click of the dial ensures accuracy the first time.

### Flawless Finish

The SD608 features the same premium materials and quality as all of Freud products. The blade bodies are laser cut for extreme accuracy, and the precision-ground arbor holes ensure precise blade alignment on any table saw. The MicroGrain carbide is manufactured specifically by Freud for splinter-free, flat-bottom grooves in all materials—including problem materials like veneered plywood or melamine.

Choose the dado set that produces the best finish and highest-quality cuts of any dado set today—choose Freud. Whether you're a production shop, custom woodworker, or serious woodworker, Freud makes it easy for you to endlessly create dados with flawless flat-bottom grooves.

For Freud's full line of high quality dado sets, go to:  
[www.freudtools.com](http://www.freudtools.com)

CIRCLE NO. 117 ON FREE INFORMATION CARD.



Cuts Clean Flat-Bottom Dados in:



**freud**<sup>®</sup>

The Psychology of Woodworking

(U.S.) 1-800-472-7307  
(CANADA) 1-800-263-7016

# Mortise & Tenon

Make woodworking's strongest joint quickly, easily and accurately.

The venerable mortise-and-tenon joint is a staple for every woodworker. There are many ways to produce it quickly and accurately but most woodworkers conclude that the router and table saw are most efficient.

Featured in this pull-out poster section is a simple, effective router jig that lets you rout accurate mortises quickly and easily. Also included are step-by-step instructions on cutting tenons with a table saw and stacked dado set.

## Mortising Jig

The mortising jig is a stout, three-sided box with a clamping device inside to hold the work and three stop blocks. Two blocks limit router travel and determine the mortise's length; the third positions the work. The other variables in your mortise (depth of cut and position on the work) are determined by the router's depth of plunge and its fence.

Start building the jig by gluing two pieces of 3/4"-thick plywood for the bottom and one side. Next, cut 3/4"-thick hardwood material for the top of the jig sides and the clamping device.

When the plywood glue-up has dried, cut the bottom and side from it. Also cut the 3/4"-thick narrower side. Glue and clamp the hardwood edges on the sides. Then glue up the pieces that form the clamping block.

When dry, use a stacked dado set to cut the grooves in the thick side that will hold the aluminum T-track. Make the cut a good fit and be sure it's flush or



Photos by Al Parrish

slightly below the wood surface. Center the track on the top edge and down 1 1/8" on the side.

The new Dial-a-Width Dado set by Freud makes setting the

perfect width of cut a breeze. Its new, patented adjustment mechanism requires only a simple turn of a dial on the outside blade to adjust the width .004" with each

click without ever removing it from the saw arbor.

## Boring the Holes

The last operation before gluing the sides to the bottom requires boring accurate holes, so use a drill press. Three holes penetrate both sides and the clamp block, and must align perfectly.

The middle hole is for the 3/8" threaded rod that tightens the clamp block. The other holes are for 3/8" steel rods, which provide rigidity to the clamp block. Here's how to drill the holes:

First place the 3/4" side on the drill-press table with the bottom edge against the fence. Now set the jig's bottom against the fence on top of the jig side as it would be assembled. Now put the clamp block in place.

Before drilling the holes in the locations indicated, place a 1/16"-thick spacer between the clamp block and the bottom. Make sure the drill-press fence is in position and drill the holes all the way through the clamp and side. As you move the work to the next hole, be sure to keep the parts aligned exactly.

The next step is to use the 3/4" jig side as a guide to drill the holes in the 1 1/2" side. This time, place the top edges of the jig against the fence with the sides' inside faces together. Now drill through the existing holes into the thick side. Again, make sure the parts stay aligned. Now chase through all three holes in the clamp block with a drill bit that's one size larger so the rods can move freely.



Also drill holes to accept the T-nut in the back of the clamp block that works with the threaded rod. Then install the T-nut.

Test-fit all three rods through the holes with all the parts together. The steel rods should fit snugly in the sides and require gentle tapping with a hammer to drive them through.

Attach the T-track to the inside of the jig before gluing the jig sides and bottom together. Use pencil lines to locate the position of the bottom on the wider side during glue-up.

Next, make the stop blocks for the T-track from a length of hardwood. See the drawing below for their shape, which prevents twisting when tightening the knob.

Install the threaded rod using "Lock-Tite," a thread-locking adhesive, to secure the star knob to



Use a stacked dado set to make two grooves in the double-thick plywood side (left). The grooves will house the T-track and require a good fit, effortlessly achieved with Freud's revolutionary Dial-A-Width Dado (below).

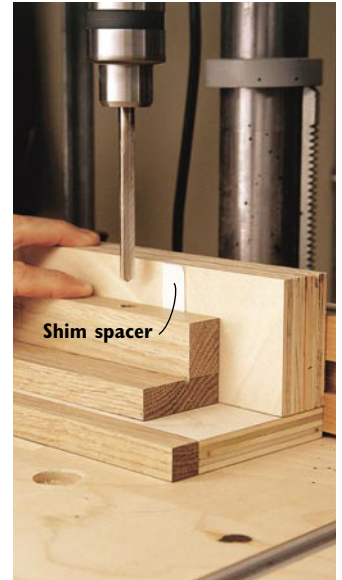
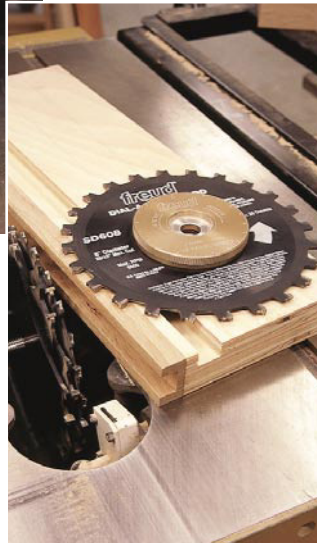

Precise drilling is required to match the holes in the sides and clamp block, positioned here with the jig bottom against the fence. Note the shim spacer between the clamp block and bottom to allow clearance when in use.

the rod. Then add a nylon-threaded stop nut on the back of the jig to keep the rod in position. As a final step, I applied a piece of coarse sandpaper to the edge of the clamp as insurance against the work slipping. After a little sanding and breaking the sharp edges, the jig is ready to go.

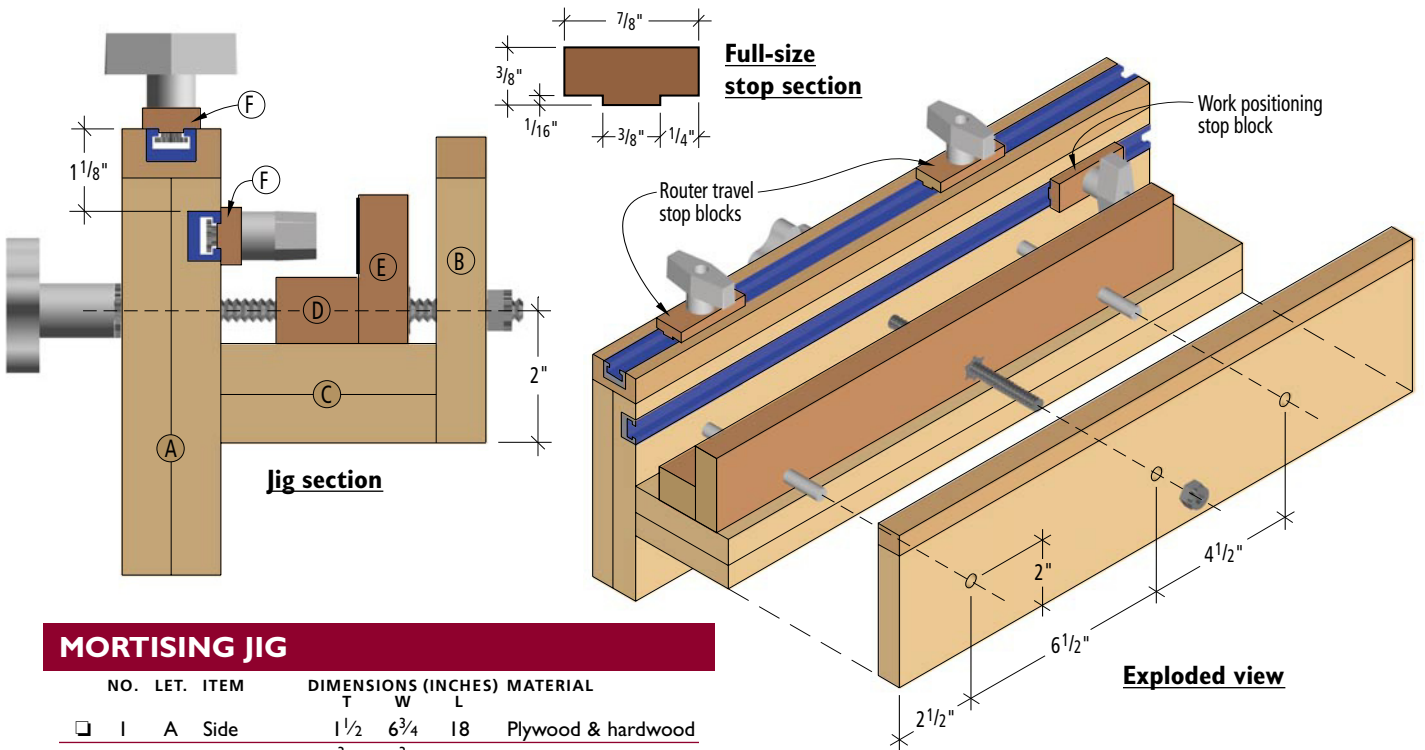

### MORTISING JIG

NO.	LET.	ITEM	DIMENSIONS (INCHES)			MATERIAL
			T	W	L	
1	A	Side	1 1/2	6 3/4	18	Plywood & hardwood
1	B	Side	3/4	4 3/4	18	Plywood & hardwood
1	C	Bottom	1 1/2	3	18	Plywood
1	D	Clamp bottom	1 3/8	16		Hardwood
1	E	Clamp side	3/4	2 3/8	16	Hardwood
3	F	Stops	3/8	7/8	2 3/4	Hardwood

Funding for this special pull-out poster provided by **freud**<sup>®</sup>  
 800-334-4107 or freudtools.com

# Mortise & Tenon

## Step-by-Step

# 1

**Getting started.** Great results come from consistently sized parts, a jig and the right tooling.

**M**ortise-and-tenon joints have lots of woodworking applications. You can join table legs to aprons, as shown here, cabinet door stiles and rails, cabinet face frames, chair parts, bed frames, sturdy workbenches and many other applications where joint strength is paramount.

The method described here is the fastest, most accurate way to make this joint. Once you make a mortise-and-tenon joint this way, you'll never go back.

The method is superior for a few reasons. One reason is the high degree of repeatable accu-

racy it offers for making both mortises and tenons. Other benefits include speed and ease of setup. The method is also superior because of the smooth walls inside the mortise (and equally smooth tenon cheeks) produced, which greatly enhance glue strength in the joint. This is especially critical because of the cross-grain orientation of the parts, which will compromise joint strength.

To use this method, you'll need the right tools in addition to the handy, easy-to-make jig described on the back of this poster. These include several quality items from

Freud, such as solid carbide, up-spiral straight router bits in  $\frac{1}{2}$ ",  $\frac{3}{8}$ " and  $\frac{1}{4}$ " sizes; a powerful plunge router like Freud's FT2000E variable-speed, 15-amp model and edge-guide fence; and the revolutionary 8" Dial-A-Width Dado that allows effortless width adjustment in increments of .004" without removing anything from the saw arbor. This new stacked dado set design eliminates the need for frustrating trial-and-error shimming to find that elusive perfect width. And as with all Freud tooling, exceptionally smooth cuts are always produced.



### 6 STEPS TO STOCK PREPARATION

- 1 Prepare all your stock for the legs, aprons, stiles and rails at the same time. It's important that stock thickness and width be uniform to ensure joint accuracy, so machine them using the same saw and/or planer setups.
- 2 When cutting project parts to their final length, also use the same setups. Be sure to use a gauge or stop block to get uniform lengths every time.
- 3 Double-check the width of your parts and make sure they are square and have the correct dimensions.
- 4 Because you'll be handling the parts during a couple of different machining setups, mark what each part is. Then mark the good face, top/bottom, etc.
- 5 Stack your parts uniformly organized by type to eliminate confusion and make sure all get machined at the same time. Also make sure they are all stacked face up or face down.
- 6 Lightly pencil mark the edges that will be machined and be extra cautious. This will keep your parts properly oriented and eliminate mistakes.

# 2

**Rout mortises first, then fit the tenons perfectly later.**

**B**ecause straight router bits come in specific diameters, it's best to rout the mortise first, then fit the tenon to the opening because the tenon thickness is more easily adjustable.

When selecting the proper-size mortise and tenon, follow the rule that the tenon should be one-half the thickness of the stock, i.e., a  $\frac{3}{8}$ "-thick tenon for  $\frac{3}{4}$ "-thick stock. For making the mortise, it's best to use an up-spiral solid-carbide straight router bit, available from Freud. This style bit is ideal because the spiral flutes eject the waste as the cut is made.

To set up the router and jig, install the bit in the router. Lay out the mortise location on a scrap piece that has the same dimensions as your good stock. Next, place the stock in the jig and secure it with the clamp block. Bring the inside stop block in contact with the stock and secure it.

Additional mortises will be positioned against the stop block for repeatable accuracy. Attach an edge guide to your router and position the tool on the jig, unplugged for now. Plunge the router down until it almost touches the stock, then lock it in position. With the fence against the side of the jig, use the coarse and fine fence adjustments to po-

sition the bit precisely. Lock the fence in place.

With this adjustment complete, set the stops on the top edge of the jig to establish the length of the mortise. Next, with the bit still down and the router unplugged, move the router until it reaches one end of the mortise layout. Bring the stop block for that end in contact with the router base and lock it. Now move the router to the other end of the mortise and set that stop in place against the router base.

Now make the final adjustment: setting the depth of cut. With the router bit in contact with the stock, use the router's depth-of-cut adjustment mechanism to set the total depth of cut. Lock the desired depth of cut in place. Adjust the tool's turret depth stops to cut the mortise in several passes of about  $\frac{1}{4}$ " each.

Before making a test cut, release the plunge lock and plug in the router. After making the first pass, check all the dimensions and adjust if needed.

If you are mortising table legs, the fence will need to be adjusted for the second mortise on each leg. Cut all on one side, then adjust the fence to align with the layout of the opposite mortise. All other settings remain the same.

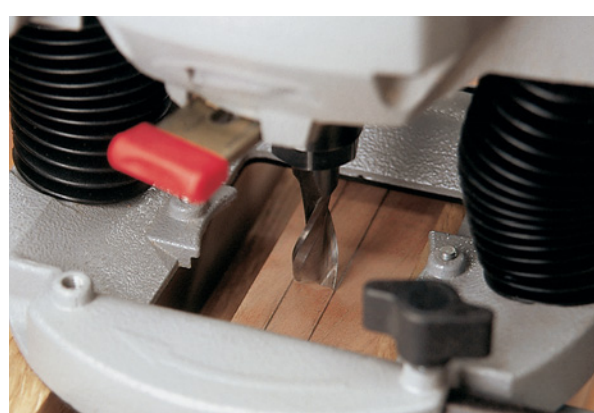

**A** With the work-positioning stop block set and the work clamped in the jig, set the router so the bit falls directly over the marked mortise position. Use both the

coarse and fine adjustment of the router's edge guide to "dial in" the exact side-to-side location and lock the setting.



**B** Move the router and position the bit at the top of the mortise layout. Note that the cutting edge has been rotated so that it extends fully to the layout line. With

the up-spiral straight bit in place, set the first stop block by bringing it in contact with the edge of the router base. Then secure the stop block.



**C** Set the limit of router travel when cutting the mortise to the opposite layout line. When in position, bring the second stop block to contact the router base and lock it in place. Set the depth of plunge for the

mortise. With the bit contacting the work, use the router's depth-stop mechanism. In this case, the mortise was  $\frac{3}{4}$ " so you can use a plywood scrap as a gauge block.

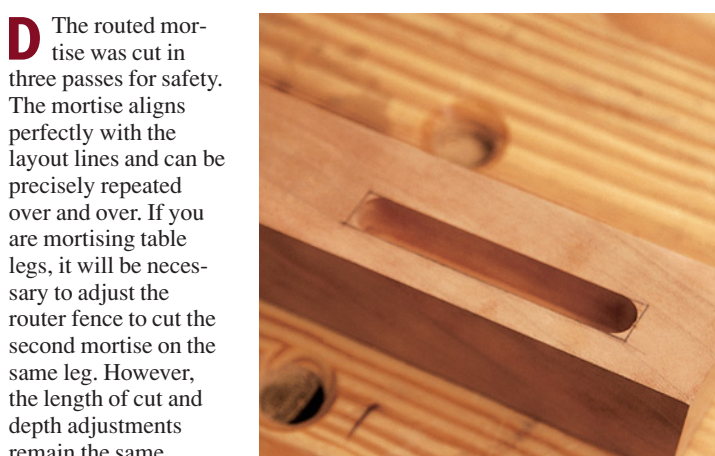

**D** The routed mortise was cut in three passes for safety. The mortise aligns perfectly with the layout lines and can be precisely repeated over and over. If you are mortising table legs, it will be necessary to adjust the router fence to cut the second mortise on the same leg. However, the length of cut and depth adjustments remain the same.

**E** If you ever wondered if it's easier to round the ends of the tenon to fit the round-ended mortise, rather than square up the mortise ends with a chisel, it's not. There's a great degree of difficulty in rounding the ends of the tenons and doing so

will likely result in a poor fit. Instead, use a sharp chisel and light mallet blows to quickly square each end. Just use your layout line as a guide. During this operation, clamp your work and position the mortise/leg over the leg of your workbench.



# 3

**Make the tenons.** Careful adjustments make a perfect fit.

**T**ime spent making fine adjustments when cutting the tenons will ensure a perfect fit. There are two adjustments to be concerned about. The first is the height of the stacked dado set above the saw's table, and the second is squaring your saw's slot miter gauge absolutely square to the saw's rip fence. It's also important to use a good stacked dado set, such as Freud's Dial-A-Width Dado, to get smooth cuts.

Start by squaring the miter gauge. This can be done easily by

using your project part to be tenoned because you've already made sure the end is square to the sides. Place the side against the miter gauge and move the part toward the saw fence. When it meets the fence, inspect it carefully for any gap between the part and fence. Adjust the miter gauge until the part is square to the fence.

Depending on the tenon length you may need to install a sacrificial fence on the table-saw fence. If the tenon is longer than  $\frac{3}{4}$ ", it won't be necessary.

To establish the tenon length, set the saw fence to the desired width as measured from the left edge of the cut on the dado.

Next set the dado height, which determines the thickness of the tenon. Use a scrap piece that's the same thickness as your stock for your test cuts. It's best to start with the stacked dado set a fraction low and "sneak up" on the final height by raising it. Because the same height of cut will cut both sides of the tenon, each adjustment will double the amount

of material removed. So just make very slight adjustments at a time.

It is important to keep the work against the fence while making the cut. Also, be sure to keep consistent downward pressure on the work as it passes over the stacked dado cutter. If the work lifts up, the final cut will be inconsistent and less than desired.

If you are using a tenon with shoulders of equal dimensions, you can cut all four cheeks with the same setup. Simply rotate the part so that all edges are cut.

**A** Once you've done the preliminary setups (fence adjustments, dado-height setting, setting the miter gauge square to the fence) cutting the tenons takes seconds. If your tenon layout has equal shoulders for each cheek, no further adjustment in dado height will be necessary. If they are different, cut the wide, face cheeks first.



**C** Flip the part 90° one more time and repeat the cut to form the second face cheek. Be sure and keep firm downward pressure on the part in order to maintain the desired tenon thickness.



**B** After cutting the first cheek, rotate the tenon to cut the edge cheek which is perpendicular to the first. Again, the tenon length is dictated by the work riding against the fence so be sure to snug the work to the fence for consistent cuts.



**D** Now complete the tenon by rotating to the last cheek to be cut. Simply repeat the cut. Examine the tenon to make sure all shoulders are even and the thickness is consistent and fits the mortise. If you plan different dimensions for your edge cheeks, adjust the height of the stacked dado set, test the set up, then cut these cheeks.



# 4

**Assembly, no squeeze-out.**

**O**ne frustrating aspect of mortise-and-tenon joints where the two parts are offset, as in a table leg and apron, is dealing with glue squeeze-out. Even the most careful cleaning of these perpendicular surfaces can result in an ugly blotch in the finish.

The problem can compound when sanding one surface creates cross-grain scratches on the other. Removing glue with a chisel can often dig into the surface.

You can easily avoid squeeze-out by cutting your mortise about  $\frac{1}{16}$ " deeper than the tenon is long. For further insurance, bevel the edges of the tenon slightly to leave a bit more room for accumulating glue in the bottom of the mortise. Lightly coat the joint surfaces with glue – you don't need a lot.

Another important point to keep in mind is to dry-fit parts to check everything out before committing to glue.

A successful glue-up will have little, if any, glue squeeze-out. In addition to taking the steps above to prevent this problem, you should consider gluing up only part of the assembly at a time. This gives plenty of time to get the process done correctly.



**freud**<sup>®</sup>  
Popular  
**Woodworking**

# What's the Secret to Flawless Glue Line Rips?

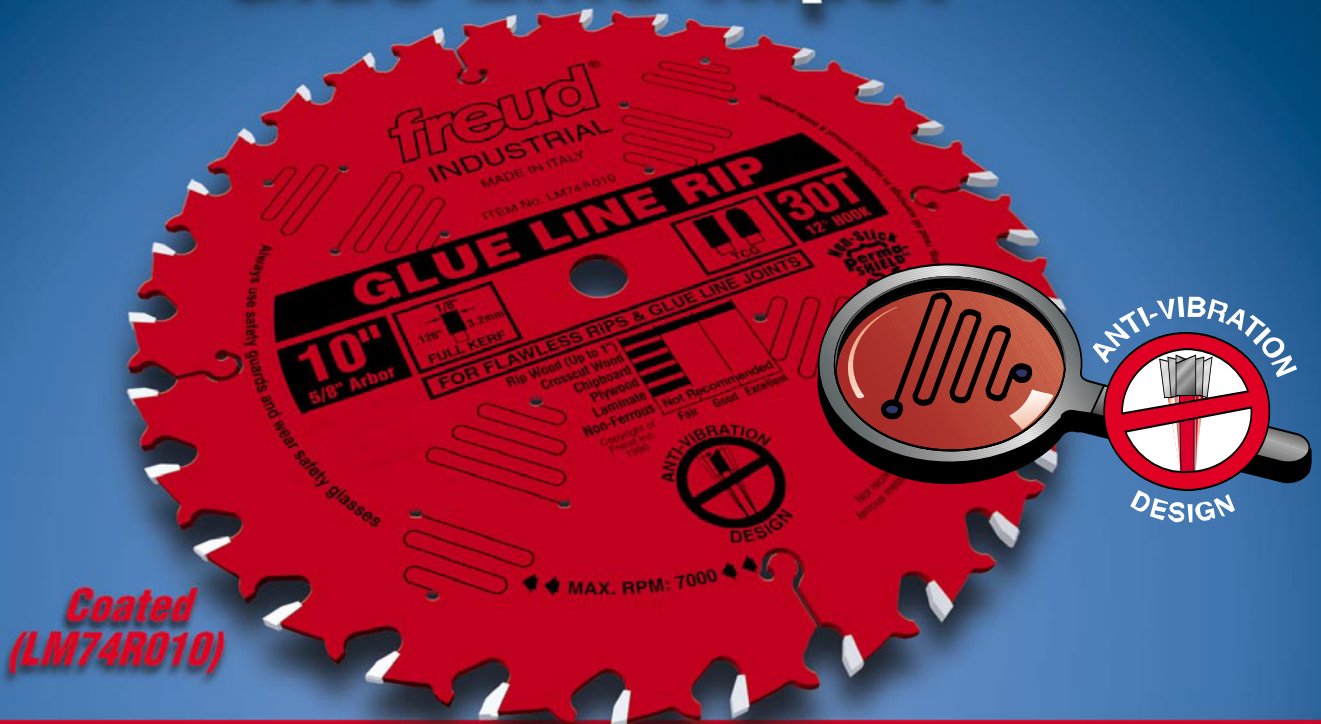

## NEW Anti-Vibration Glue Line Rip Blades by Freud

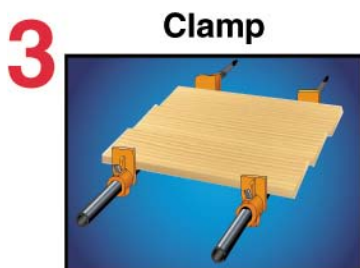
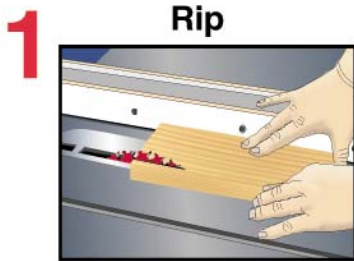

### Put your jointer away when you use these Freud Blades

In the past, producing flawless glue joints required jointing or sanding.

**Not any more!**

Freud's new Anti-Vibration Glue Line Rip Blades are designed to improve workmanship as well as eliminate unnecessary rework.

Standard saw blades that vibrate cause swirls that lead to poor joints. Freud's unique Laser-Cut Anti-Vibration Slots virtually eliminate vibration and sideways movement of the cutting edge against the material. Now, you can rip, glue and clamp your project eliminating the need for sanding or jointing.

The triple chip teeth feature special micrograin carbide manufactured and designed by Freud to withstand the impact encountered when ripping hard and softwoods. These blades are ideal for ripping 1/8" to 1" Maple, Oak, Pine and even exotic hard and softwoods and are available either with Perma-SHIELD™ coating (non stick coating that prevents heat and pitch build up increasing the cutting life of a saw blade) or polished finish.

Whether you're a production shop or a custom woodworker, Freud makes it easy for you to create strong, flawless glue joints.



**Rip Cut with Freud Blade**



**Rip Cut with Other Blade**

**freud**®

The Psychology of Woodworking

**ISO 9002**

CERTIFIED TO ISO 9002 BY A 12 103 3000

FOR MORE INFORMATION CALL 1-800-472-7307  
IN CANADA CALL 1-800-263-7016  
[www.FreudTools.com](http://www.FreudTools.com)

Red saw blades are a registered trademark of Freud TMM, Inc.  
CIRCLE NO. 175 ON FREE INFORMATION CARD.

If your fence assembly isn't designed to have offset fences, you can achieve the same effect by building up the face of the outfeed table with a piece of laminate or thin plywood. Adjust the outfeed face to match the bit and you're ready.

## Featherboards & Stop Blocks

Two useful accessories for the router table are featherboards and stop blocks.

- Featherboards are most often thought of as safety devices, and they certainly are, but they also help ensure an accurate cut from the bit. For safety, a featherboard's angled fingers allow the wood to pass the bit and then applies pressure in the same direction you are feeding your work to make it nearly impossible for the piece to kick back (which is when the material is thrown toward the user by the force of the spinning bit). A pair of featherboards used in the horizontal and vertical planes of the router table, as shown in the photograph below, add excellent safety.

Often when using larger-diameter bits in a single pass, the tendency of the bit is to push the material away from it, causing irregular, rippled or shallow cuts. Using a pair of featherboards will keep the workpiece pushed tightly against the fence, table and bit, providing an accurate, smooth and repeatable cut.

- When using a router table, the bit is buried in the wood during the cut and you can't see when or where the cut

**When using a fence, attach featherboards to both the fence and the table to keep the workpiece properly positioned. Featherboards provide firm, even pressure and prevent the piece from kicking back toward you. Also use push sticks and push shoes to feed the workpiece, keeping your fingers out of danger.**

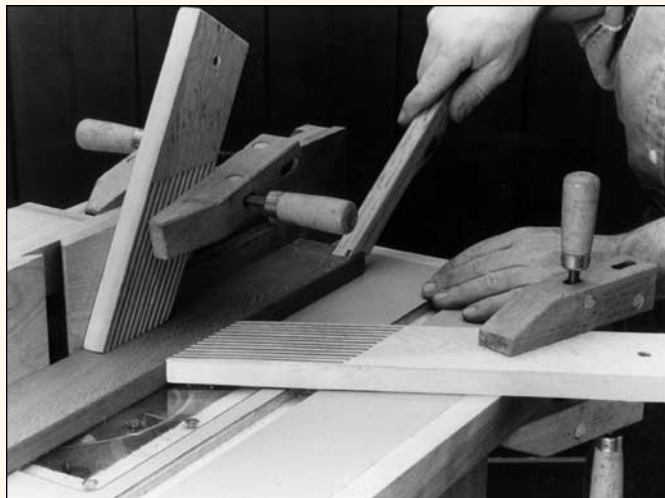

**You also can use a fence as a stop to prevent creep. However, the fence must be precisely parallel to the miter-gauge slot and you must be feeding the workpiece with the rotation of the bit to pull the piece against the fence.**

begins or ends. When making a stopped cut of any type (groove or profile), you need to know the stopping and starting points to make an accurate cut.

One way to determine those points is to make a pencil mark on the fence identifying the infeed and outfeed sides of the bit. This helps, but it isn't a positive assurance of accuracy.

That's where stop blocks come in handy. By mounting some adjustable blocks to the fence (using either integral T-tracks or a clamp on the fence) you can be sure you'll always stop and start in exactly the correct spot.

## Using a Miter Gauge

A miter gauge is a simple way to ensure you get square cuts on the ends of thin stock when using a router table. Just place the stock against the face of the gauge and feed it past the bit as if it was the blade on a table saw.

But there is an important difference – the rotation of a saw blade helps hold the work against the gauge; the rotation of the router bit pulls the wood sideways, making it “creep” across the gauge to the right as you cut.

When not using a fence, there are several things you can do to prevent this:

- Mount an extension (a long, auxiliary face) on the miter gauge and clamp the work to this.
- Clamp a stop to the miter-gauge extension and butt the workpiece against the stop.
- Position a fence beside the miter gauge and let the end of the board ride along the fence as you cut.
- Tape #80-grit or #100-grit sandpaper to the miter gauge face with double-sided carpet tape.

It's also a good idea when crosscutting material on the router table to use a backing board against the face of the miter gauge. This will significantly decrease tear-out on the workpiece and add some more stability.

# TIPS & TRICKS

## PRO TRICK: Need Good Dowels? Just Make Your Own



By rounding-over the four arrises of a square workpiece (where the edges and faces meet), you can make your own dowels on a router table. The width and thickness of the workpiece should be precisely twice the radius of the bit. As you rout, leave about 2" of stock uncut on either end of the piece to keep the work stable on the router table.

## GREAT TIP: Drawers Help Maximize Space in Your Table



If you're making your own router table, you can choose either a portable bench-top version or take advantage of the extra storage space in a floor model by adding drawers to store all your bits and any useful jigs and accessories.

## Making a Mounting Plate

If you buy a router table, many will come with a mounting plate – a thin, flat sheet to which you attach the router base. The plate is needed to mount the router in any stationary jig, including the table.

If you're making your own table, or if the one you purchased doesn't come with a mounting plate, don't worry – making the plate is rather straightforward. All you have to do is cut the material to size, drill a few holes and screw the plate to the jig or table. However, you must make several informed decisions as you fashion this simple part.

- The material from which you make a mounting plate must be strong enough and dense enough to absorb the vibrations of the router, but thin enough so it won't restrict the depth of cut. You should be able to cut and drill the material easily, and it should be transparent so you can see what's going on beneath it. There is really only one material that fulfills all these requirements – transparent plastic. I suggest you use ordinary acrylic plastic that's rather inexpensive. Some structural plastics are super-strong, but too flexible. Acrylic is more rigid. I suggest using a 1/4"-thick sheet for routers up to 1 1/2-hp and a 3/8"-thick sheet for more powerful routers.

- For safety and accuracy, there should be as little space as possible between the work surface and the router bit

where it protrudes through the plate. However, bits can range in size from 1/16" to 3/4". So what can you do? I suggest you drill the opening about 1/4" larger than the largest bit you own, then make several inserts to fit the opening. Use the same transparent material that the mounting plate was made from and just drill a different diameter hole in the center of each insert so you have a variety to choose from.

- Once you make these inserts, you're going to need to fashion some way to hold them in place. Some router bases have metal or plastic flanges to mount guide bushings. If your router is so equipped, you can use these flanges to support and secure the inserts. If your router doesn't have built-in flanges, attach a plastic ring under the mounting plate. The inside diameter of this ring should be 1/2" smaller than the diameter of the mounting plate to create a ledge to support the inserts.

- To cut an opening in the table's work surface for the mounting plate, first rout a square groove in the surface. Clamp a wooden frame to the table to guide the router and cut the groove so the depth matches the thickness of the mounting plate. (Make this groove about 1/32" smaller than the circumference of the plate; later, you can sand or file the edges of the plate to get a perfect fit.) Then make the router opening by

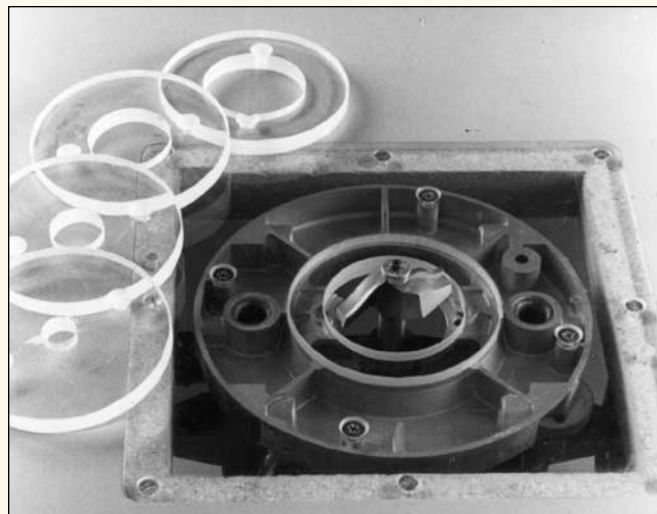

Because router bits can range in size from 1/16" to 3/4", you should drill the plate's opening about 1/4" larger than the largest bit you own. Then you can make several inserts out of the same acrylic you used for the plate.

## A BIT OF ADVICE

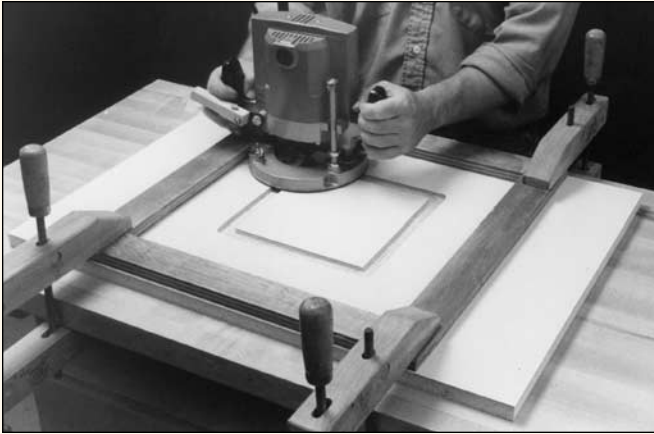

To cut the work surface for the mounting plate, first rout a square groove. Clamp a frame to the table to guide the router and cut the groove as deep as you want the thickness of the mounting plate.

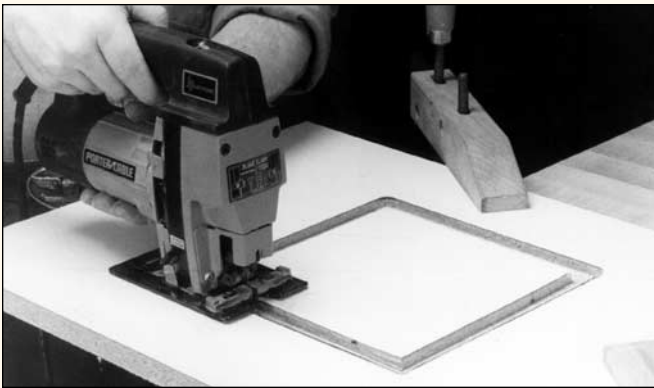

Next, make the router opening by cutting the inside edges of the groove with a jigsaw. This groove will then form the ledge to hold the plate.

cutting around the inside edges of the groove with a jigsaw. When the waste falls away, the groove will form a ledge to hold the mounting plate.

- You can attach the mounting plate in the opening with several screws. Don't leave it loose, because you don't want it to shift as you work.

- The work surface should be thick enough to permit you to attach the mounting plate securely – short screws may vibrate or pull loose. If the work surface is less than 1 1/4" thick, build up the area immediately beneath the mounting plate by gluing a hardwood frame to the table.

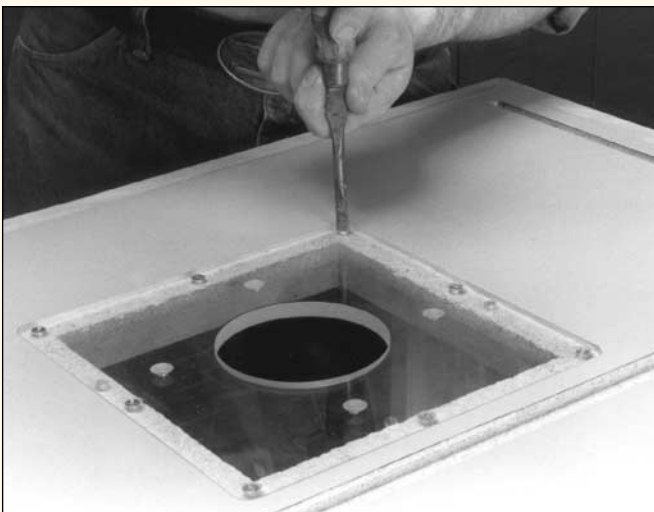

Screws work great to attach the mounting plate in the opening, but make sure you do it tightly – you don't want anything shifting while you work.

A router bit consists of a cylindrical shank (usually 1/4" or 1/2" in diameter) and one or more flutes or cutting wings, usually comprised of a piece of carbide brazed to the metal body of the bit. Throughout this series, we will be providing a closer look at many of the common and specialized bits that can be used with your router. These three bits are great for use with the router table.

### Crown-moulding Bit

Designed to make complicated profile shapes in one pass, a crown-moulding bit is a perfect choice for a router table



because of its size and the quantity of wood likely to be run.



### Table-edge Bit

Because the bit is designed to remove a lot of material in one pass (and run a lot of material at one time) a router table offers power and control for many edge profile

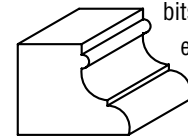

bits. Table-edge bits are large and require more power and control.



### Raised-panel Bit

Another large bit perfect for router tables is a raised-panel bit for making doors and frame-and-panel cabinetry. The one shown here is a horizontal bit, but vertical bits also are available.

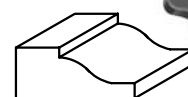

## Height Gauge

Sometimes you need three hands to adjust the depth of a cut on a router – one to raise or lower the motor, one to secure the height clamp and one to hold the measuring device. And if the router is in a table, you may need to be extremely flexible to scrunch down and read the rule.

This simple shop-made height gauge eliminates the need for one of those extra hands and most of the contortions. The gauge is stable enough that it does not have to be held and the scale can be read accurately from most angles. You can use the gauge with the arm facing down to measure heights of less than 3" or with the arm up for heights between 3" and 6". This gauge also can be used with a shaper, table saw, dado cutter or any other tool or accessory in which the blade or cutter protrudes through a worktable or fence.

You also can use the gauge to measure the position of a router-table fence in

relation to the bit. Just set the gauge and hold it against the fence with the arm encompassing the bit. Then move the fence forward or back until the side of the bit touches the arm.

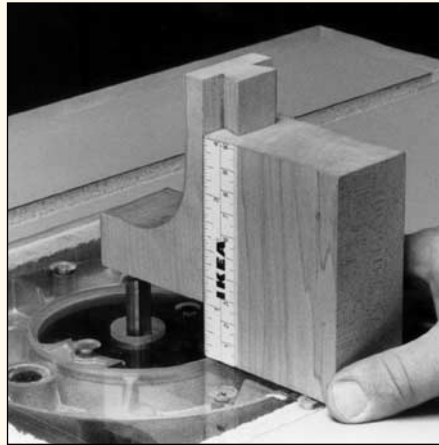

To use the gauge, set it to the desired height. Place it on the router sole or mounting plate with the arm over the bit. Raise or lower the bit until it touches the arm.

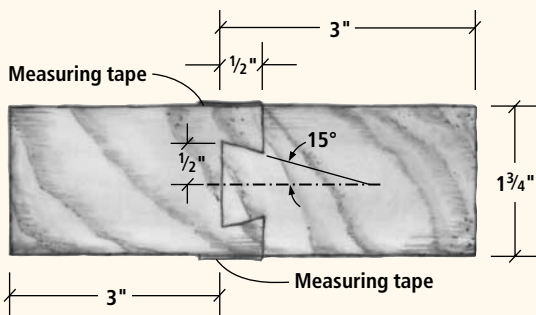

Top view

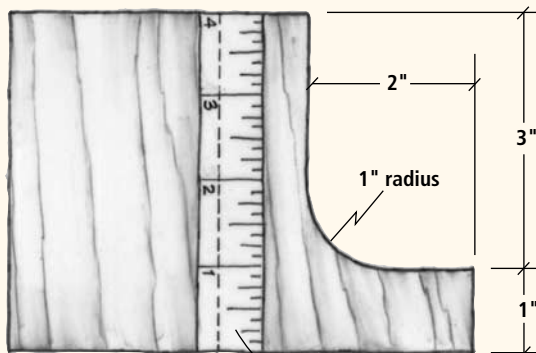

Side view

1"-4" measuring tape  
(3"-7" on reverse side)

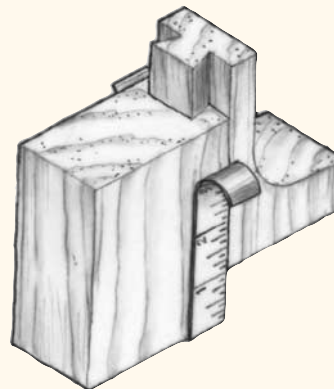

Exploded view

## Everything you need to know about the router in our special series!

For many woodworkers, one of their first tools is the router, but there often isn't enough instruction about how to use it. This series aims to fix that by giving you everything you ever wanted to know.

### Chapter 3 The Router Table

Learn which routers work best in a table, how to use a miter gauge and how to make a mounting plate. Plus lots of table tricks.

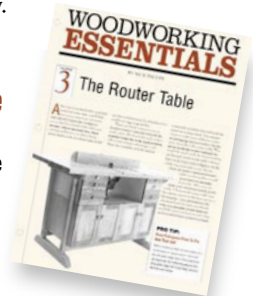

### COMING IN FUTURE ISSUES

#### Chapter 4 Router Joinery

A great tool for joinery, we tell you how to rout all kinds of tight joints.

#### Chapter 5 Use Your Router to Build Drawers

An excellent application for a table or hand-held router.

#### Chapter 6 Edge & Surface Treatments

Spice up your projects with these special edge shapes.

#### Chapter 7 Advanced Techniques

We comb our resources to give you some special tips and projects to work on.

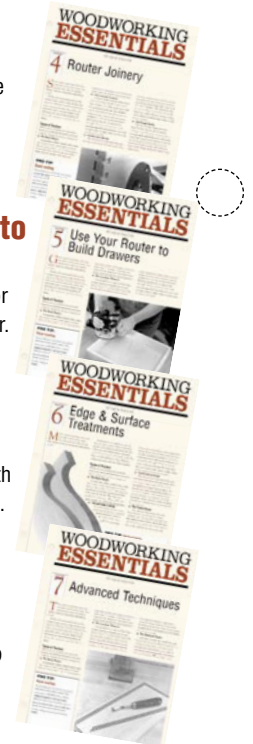

### IN PAST ISSUES

#### Chapter 1 Fixed-base Router

The basics of router set-up and rules every woodworker should know.

#### Chapter 2 Plunge Router

An in-depth look at versatile plunge routers.



# The Toughest Glue On Planet Earth

Gorilla Brand Premium Glue is the all purpose, interior/exterior glue ideal for most repair and bonding needs. It's great for indoor/outdoor furniture repair, woodworking projects, as well as general repairs around the house. Bonds wood, stone, metal, ceramic and more! Incredibly strong and 100% waterproof.



for retailers near you:  
[www.gorillaglue.com](http://www.gorillaglue.com)  
1-800-966-3458

CIRCLE NO. 120 ON FREE INFORMATION CARD.

## QUARTERSAWN HARDWOODS & HIGHLY FIGURED LUMBER

Ash, Cherry, Hard Maple, Red Oak, White Oak, Walnut, Sycamore, Mahogany, Hickory, and Birch. Also, many *Exotic Species* in Stock.

**NEW** We now have  
Curly Bubinga, Curly Makore  
& other figured exotics

WEST PENN HARDWOODS, INC.  
(888) 636-WOOD (9663)  
[www.westpennhardwoods.com](http://www.westpennhardwoods.com)

## Collect Dust!

1.5hp - 20hp  
Dust Collection  
Systems & Components

- ▶ **FREE** Ductwork Design Service
- ▶ **FREE** Product and Ductwork Catalog!

Call Us Today!

**1.800.732.4065**

**Online Ordering**  
[www.oneida-air.com](http://www.oneida-air.com)

1001 W. Fayette St., Syracuse, NY 13204



CIRCLE NO. 139 ON FREE INFORMATION CARD.

# YORKCRAFT®

The perfect union of quality with low price!

### YC-15P 15" Planer

with 3 hp 1 ph motor and 3-knife cutterhead

**\$699.00**

FEATURES: Table height is fixed, motor and cutterhead adjust up and down. Jack screw knife adjustment. Two feed speeds. Dust hood. Enclosed stand.

### YC-20P 20" Planer

with 5 hp 1 ph motor and 4-knife cutterhead

**\$1199.00**

FEATURES: Table height adjustable. Jack screw knife adjustment. Two feed speeds. Dust hood. Solid, cast iron table extensions. Enclosed stand with built in wheels for mobility.



YC-15P shown with optional mobile base

### YC-6J 6" Jointer

with 1 hp 1 ph motor and 3-knife cutterhead

**\$299.00**

### YC-8J 8" Jointer

with 1-1/2 hp 1 ph motor and 3-knife cutterhead

**\$649.00**

FEATURES: Center-mount fence with rack and pinion adjustment. Fence tilts both directions to 45°. Jackscrew knife adjustment. Enclosed stand. Rabbing table and ledge. Dust hood included.



The YC-8J Jointer features an extra long 72" table

Prices: FOB, York, PA  
Subject to change without notice

**WILKE**  
MACHINERY COMPANY  
MACHINERY POWER TOOLS

For information and a **FREE** catalog  
**1-800-235-2100**  
[www.wilkemach.com](http://www.wilkemach.com)

write or visit our showroom:  
3230 N Susquehanna Trail, York, PA 17402-9716



CIRCLE NO. 155 ON FREE INFORMATION CARD.



# CLASSIC

# Chessboard

Nothing you build will be examined as closely as a chessboard. Here's how to do it perfectly.

**B**uilding any kind of box can be a little challenging. Coving its sides can make it a little more time-consuming. But making a chessboard lid out of 64 small square blocks of wood so all the corners match up neatly can be totally overwhelming. And trust me – nothing receives quite as much scrutiny as the top of a handmade chessboard.

But there is no reason to be afraid of making a chessboard. All you need is some basic woodworking experience, a well-tuned table saw and, most importantly, lots of patience.

I tackle this project in four steps:

- First I prepare the wood.
- Next I make the chessboard, which will be inset in the box lid.
- Then I assemble the box.
- And finally I cut the lid off the box, install hinges and finish the piece.

As with any project, quality materials are important. For my chessboards, I use walnut and maple, although any contrasting woods will do. Select wood that is equally dry, and joint and plane it to thickness. As always, your wood must be straight.

## 8 Strips = 64 Squares

A chessboard is made up of 64 square blocks. Thirty-two squares are dark and 32 are light. If the corners of the squares don't line up properly, the contrasting colors will make any gaps extremely noticeable and the project will be ruined. The prospect of accurately cutting and gluing together 64 blocks is daunting, so don't do it. Instead, make the squares in strips.

by Barry Black

---

*Barry Black builds custom furniture in Red Deer, Alberta, Canada, using hand tools as much as he can. His passion for antique hand tools has become a sideline and he sells them on his web site, [blackboardcreations.com](http://blackboardcreations.com).*





First cut four strips of walnut and four strips of maple both 2" wide and carefully edge-glue them together, keeping the ends aligned, as shown below. When the glue has dried, true up one end by cross-cutting the assembled panel on your table saw.

Note: You don't want to move the table saw's fence to do this. Use an accurate miter gauge or crosscut sled. Then, with the fence still set at 2", crosscut the panel into 2"-wide strips again, as shown below. Here are some secrets to successful square cutting:

- Make sure your table saw's blade is set at 90° to the table and your table saw's fence is perfectly parallel to the blade.

- Don't move the table saw's fence between cuts.

- Use a blade stiffener to avoid any chance of blade flutter.

- Keep the blade low to the work (one tooth above the wood is a good rule of thumb).

- Try not to pause part of the way through a cut. This will produce a slightly wider cut at that part, which would be very noticeable on a chessboard.

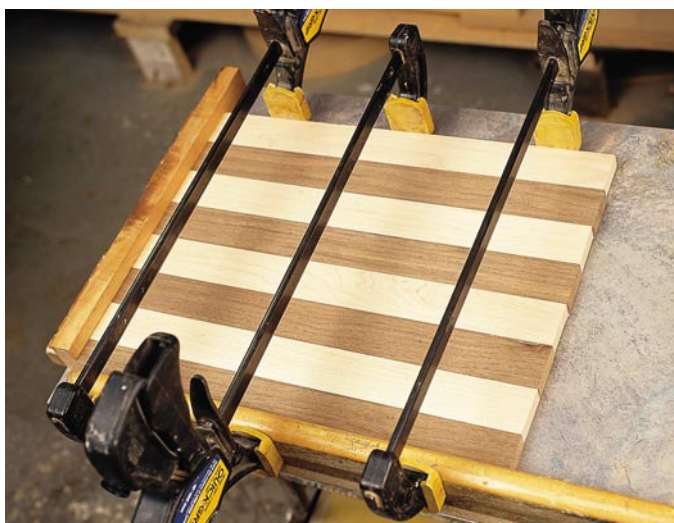

The first step in making a gap-free chessboard top is to glue together eight maple and walnut strips, alternating between the species.



Next, you need to recut the maple and walnut board into eight 2"-wide strips.

## CLASSIC CHESSBOARD

NO.	ITEM	DIMENSIONS (INCHES)			MATERIAL
		T	W	L	
4	Strips	9/16	2	17*	Maple
4	Strips	9/16	2	17*	Walnut
4	Chessboard splines	1/4	1/2	17	Walnut
4	Box sides	3/4	3 5/8	17 3/4	Walnut
4	Miter splines	1/8	1/4	3 5/8	Walnut
1	Bottom	1/4	16 3/4	16 3/4	Plywood
2	Base	3/4	1 5/8	18	Walnut

\*The length is correct; the additional inch is needed for saw blade kerf.

You now have eight strips of wood 2" wide. Rotate every other strip end for end and glue them back together, as shown below. Make sure you glue the pieces back together on a flat surface and use a jig similar to the one I used in the picture.

After the glue has had time to cure, you can plane or sand all surfaces to remove any irregularities. If you own a planer, unplug it. The grain of the blocks will be running in different directions because of the construction method we used and there is a good chance of some severe tear-

out. For years I hand-planed and scraped the surface smooth. These days I used a drum sander and it works just fine.

Now cut the groove around the edges of the chessboard for the splines that secure the board in the lid. This can be done by making a couple of passes on your table saw with the blade set up to 1/4". Then plane a light chamfer around the outside top surface of the board and sand in stages up to its final grit (I go to #600 grit). The underside of the lid will be visible when opened, so make sure you sand both sides.

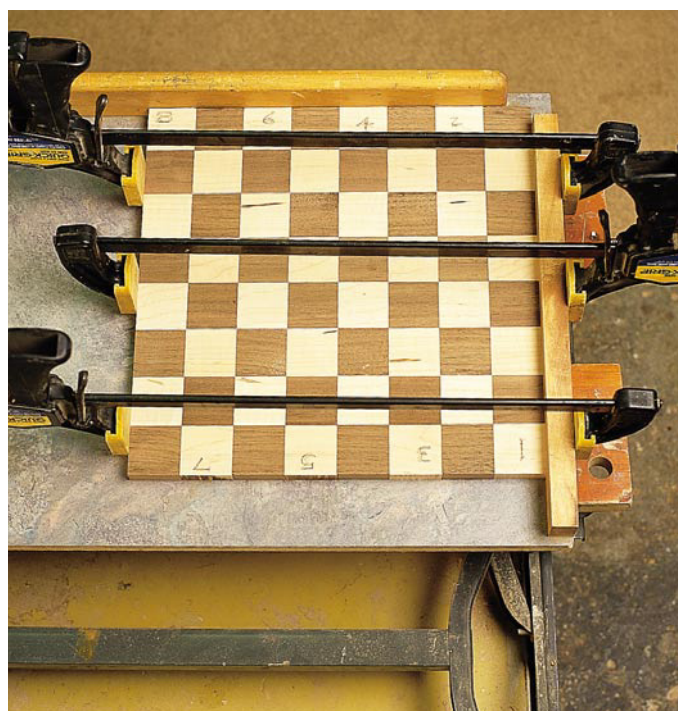

Then reglue the strips, alternating between the species to form a chessboard.

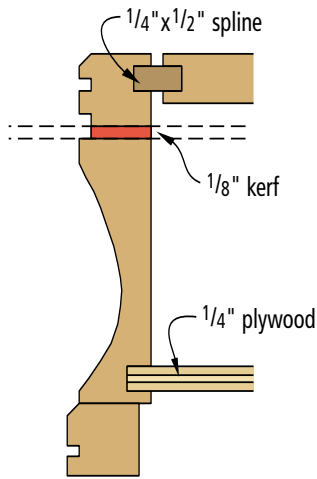

Half-size section detail

**Coving the Sides**

I build the lid as part of the sides, then cut the lid free on the table saw. The box has four sides of equal length with mitered corners. To reinforce the miter joints, I use a spline, which adds a lot of strength and a subtle design element. I also like to add a cove to the sides of the box.

Coving, an act that is easily achieved using your table saw, can be done prior to building the box or after. I prefer doing it before, just in case a calamity of some kind happens, destroying all of my work to that point.

The procedure is really quite simple. Basically, just pass the wood across the blade at an angle and take very light cuts, maybe 1/16" at a time. I use an 80-tooth blade because it produces a cleaner cut and leaves me with less scraping to do afterwards. Less scraping is always a good thing.

To make the cove pictured on page 70, bevel the blade to 45°. This gives something approaching a parabolic curve, but changing the angle of approach and the slope of the blade can produce a variety of profiles.

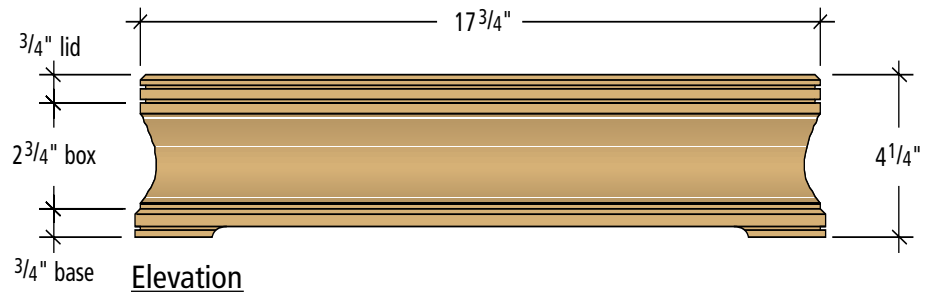

Elevation

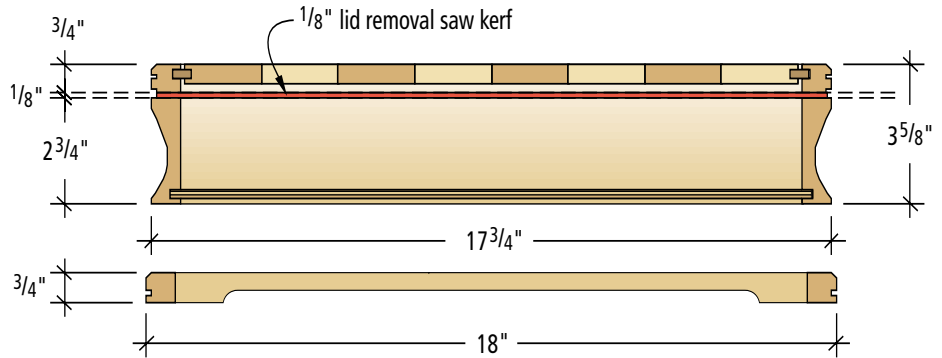

Lid, box & base sections

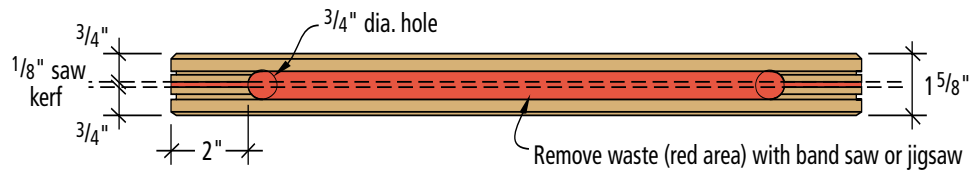

Base stock plan

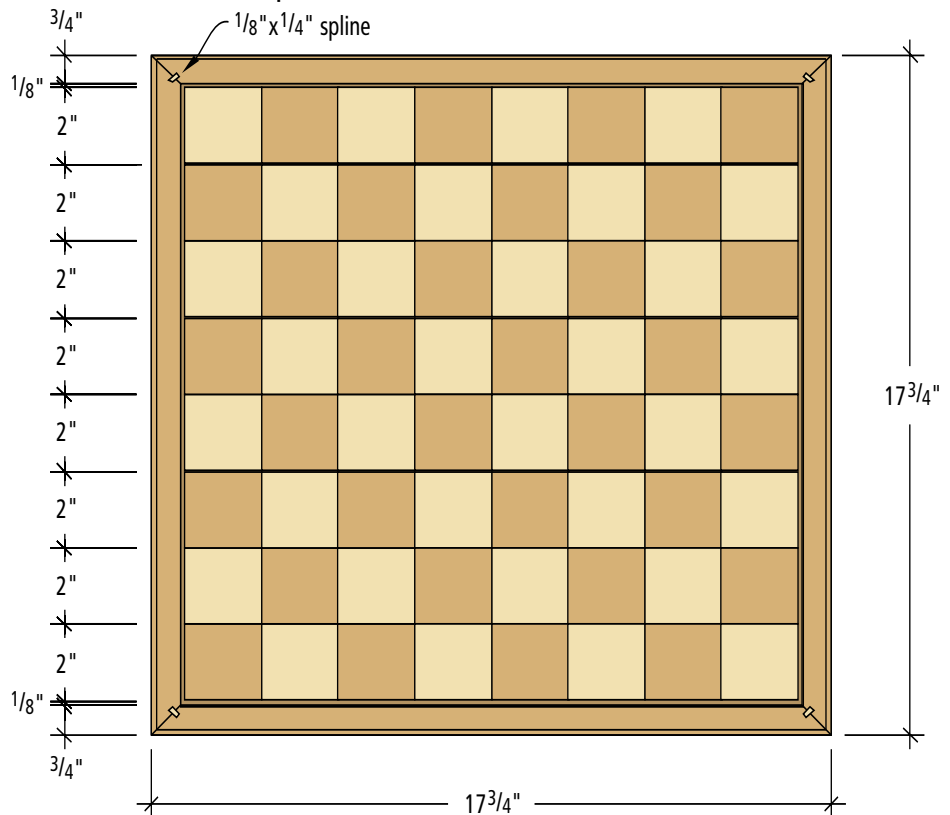

Plan

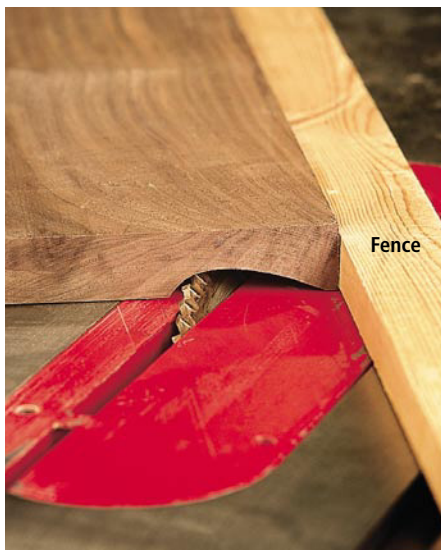

A straight-edged board clamped across the table saw acts as a fence when cutting the cove.

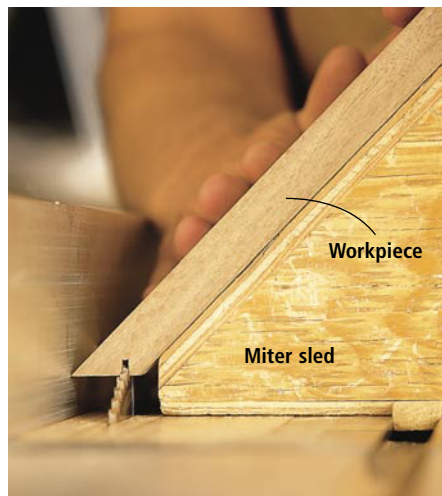

On my first table saw, the table tilted rather than the blade so I made a sled to hold my work at 45° instead of tilting the table. I still use my sled, and here I'm using it to cut a kerf for a spline.



Here I'm cutting a groove in the coved side pieces, which will hold the plywood bottom.

Clamp a straight-edged board across the saw to act as a fence, then make multiple passes. Sometimes if the workpiece is long and I'm alone, I'll clamp a second board parallel to the first so the workpiece travels between the two, just to keep things running smoothly. The pieces for this project will be more than four feet long, so I recommend using the second guide.

As a safety precaution, always use proper push blocks when coving. It's a lot like jointing: The workpiece needs to be held down over the blade, and that should never be done by hand. Once you've raised the saw blade to the finished height (about  $\frac{3}{8}$ " ) the coving is complete.

### Building the Box

Once the coving is done, cut the side pieces to rough length and then accurately miter them. Next, using your table saw, cut  $\frac{1}{8}$ "-thick x  $\frac{1}{8}$ "-deep kerfs for the splines in the mitered ends. Instead of angling the blade, I use a homemade sled, as shown above. Although I'm able to angle my blade, I find it to be very awkward.

To deter tear-out, always back up the cut with a piece of scrap wood so that when the blade exits the work it does so cleanly. These slots need to be kept fairly close to the inside corner so they don't break through into the thinner area created by the coving. To make the splines, rip a piece of walnut just less than  $\frac{1}{8}$ " thick on the table saw and crosscut them just less than  $\frac{1}{4}$ " with a fine hand-

saw. The grain on the splines must be perpendicular, not parallel, to the length, for additional strength.

Now cut the  $\frac{1}{4}$ " x  $\frac{1}{4}$ " groove on the inside of the box sides for the bottom plywood piece and the splines for the chessboard, which nest in the groove cut in the edges of the chessboard. Don't glue these parts in. It's necessary to allow some float, accommodating seasonal changes.

Next, sand all the inside faces of the box and apply masking tape to the inside edges of the box sides to help gather any glue that squeezes out. Masking tape with glue on it is easier to remove than hardened glue in the corners.

Then you can dry-assemble the box to ensure that everything fits properly. If it does, glue up the piece on a nice, flat surface. My splines extended a little above



I use surgical tubing to clamp together the sides after glue-up. The tubing (available from Lee Valley Tools, 800-871-8158 or [leevalley.com](http://leevalley.com)) applies even pressure to the joints.



Plane a light chamfer along the top edge of the box so it matches the top edge of the chessboard.

the top edge so I pared them off with a sharp chisel later. Never leave them below the surface – it looks terrible.

Instead of clamps, I've found I get better results wrapping several passes of surgical tubing around the box, as shown on the previous page. Surgical tubing can be stretched tightly, applying pressure evenly to the joints. This is hard to do if you're alone, so you may need to start with clamps. Once the box parts are positioned properly, put the tubing on and remove the clamps.

After checking to make sure everything is square, let the box sit overnight. The next day, clean up any squeezed-out glue at the joints then carefully cut around the outside of the box to remove the lid, as seen at right. The edges of the box and lid will need a little cleanup, something you can do with a sharp block plane.

### Building the Base

In my opinion, this box looks more elegant on a base. I make a simple base using two pieces of  $\frac{3}{4}$ " walnut,  $1\frac{5}{8}$ " wide and  $\frac{1}{4}$ " longer than the sides. I miter the ends, then stick them back to back with double-sided tape.

On the center line, drill a  $\frac{3}{4}$ "-diameter hole 2" from each end. Then cut through the center along the length. Using a band saw or jigsaw, cut away the waste between the holes and clean this up using a block plane and rasp. This will yield four  $\frac{3}{4}$ " x  $\frac{3}{4}$ " sides, which can be mitered and glued together to produce the base. This, in turn, can be glued to the bottom of the chessboard.

I don't use a spline in the base's miters because with everything glued together, strength isn't an issue. Before doing the final glue-up, plane a light chamfer along the top edge to match the one at the chessboard's top edge.

Also be sure you clean up the coved sides. I like to do this with handmade scrapers. I use old hand-saw blades I get at garage sales and cut them to fit the profile. A piece of sandpaper wrapped around a large dowel also will work, as seen at right.

### Checkmate

When you play chess, your right-hand corner square must be white. I like to open the lid like a book so I put the hinges on a side. This way both players can look into the box when it's opened to remove their chess pieces.

I mortise the hinges into the box and lid, slightly less than half

the height of the hinge. Once the lid has been fitted, the outside can be sanded and then the whole piece can be finished in whatever way you choose.

My wife lined the bottom of the box with some felt while I made dividers to separate the pieces. This isn't really necessary, but it is a nice surprise when the lid is opened.

Once finished, take some time to sit down and challenge a friend to a good game of chess. **PW**

*To make your own chess pieces, check out "Wooden Chess Pieces You Can Make" (Fox Chapel Publishing) by Diana Thompson, available online at [woodworkersbookclub.com](http://woodworkersbookclub.com)*



Although I use handmade scrapers to clean up my coves, you can just as easily use a piece of sandpaper wrapped around a large dowel, as shown here.

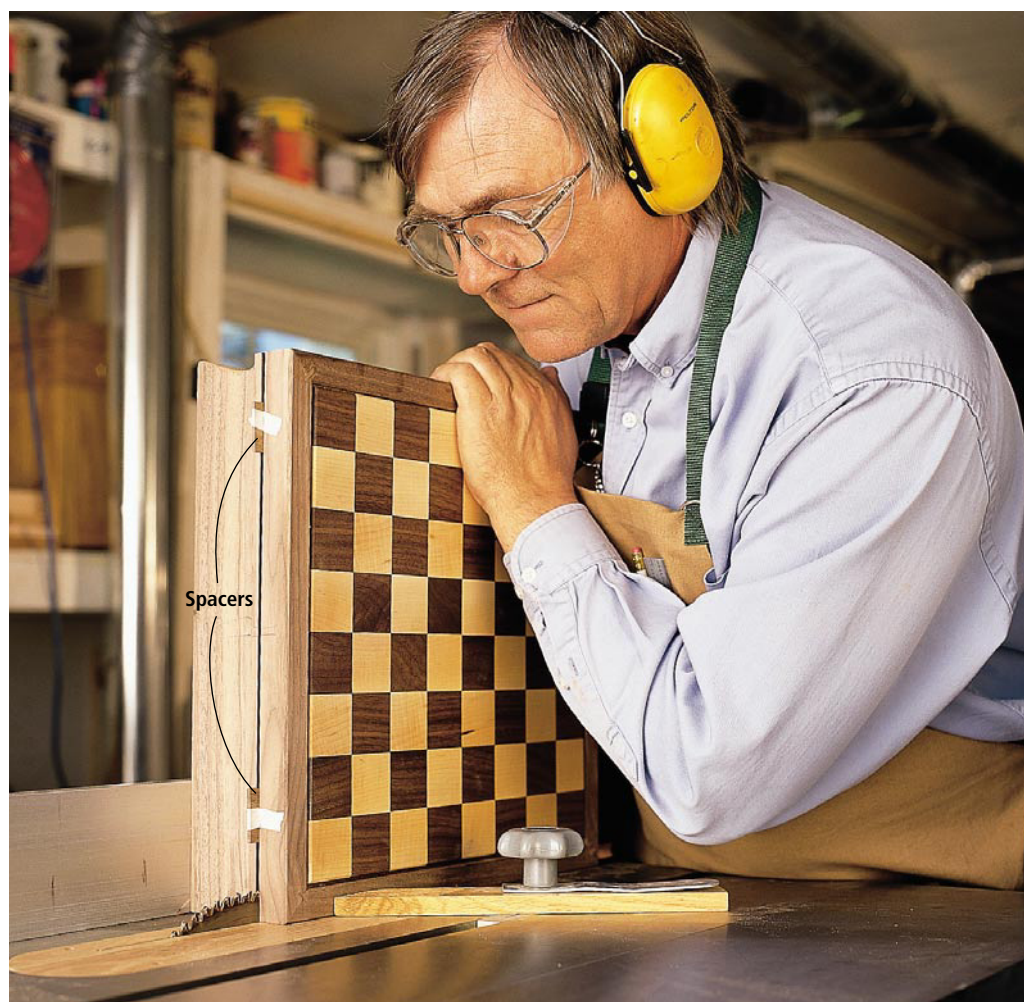

Once the box is glued up, cut the lid using your table saw as shown here. Note that I've taped spacers in the kerf once the cut was made to keep from pinching the blade as the top is cut free.

# Golden Formulas

## for Better-looking Furniture

Three simple techniques to please the eye.

**P**roportion is an essential element of good furniture design. In fact, it's arguably the most important element. No amount of careful craftsmanship or dramatically figured lumber will save a disproportionate piece.

Many woodworkers have likely found this out the hard way. It's disheartening to spend many hours or days carefully crafting a piece of furniture only to be disappointed with the finished product. Drawings and mock-ups help visualize the piece. However, before you make your first drawing or mock-up, take the time to develop the proportions. It'll pay off in the long run.

by Lonnie Bird

---

*Lonnie Bird is the author of "The Complete Illustrated Guide to Shaping Wood" (The Taunton Press) and teaches woodworking. You can learn more about his woodworking classes at [lonniebird.com](http://lonniebird.com).*



Although this chair has many curves, the first step in its design is to fit the overall dimensions within a rectangle.

Photos by the author

Proportion is the size relationship between various parts, as well as from those parts to the entire piece. For example, the feet on a desk or chest should appear in proportion to the casework. If the feet are too small, the casework will visually overpower them and make them appear weak or fragile. If the feet are too large, they can make the chest appear awkward or clumsy. Mouldings, doors, drawers and other details must all be in correct proportion if the work is to be a visual success.

But how do you create good proportions when designing furniture? One way is to use mathematical systems. You've probably heard of the golden section (also called the golden ratio): It's a ratio (1:1.618) that's found in many natural objects – including the human body – that's been used for centuries by artists, designers, architects and craftsmen.

### The Golden Section

The golden section was discovered by the ancient Greeks and is still widely used today. Not surprisingly, the ratio of the golden section, 1:1.618, is very close to the ratio of 5:8, two of the numbers in the Fibonacci series (which we'll discuss later).

Of course, the ratio of the golden section can be used to create a golden rectangle. You can find the golden rectangle in a wide variety of well-proportioned items, both natural and man-made. For example, the facade of the Greek Parthenon fits within the golden rectangle. A credit card (2 1/8" x 3 3/8") also fits within a golden rectangle. And many items found in nature fit within a golden rectangle. Here's an interesting twist to try on your own – draw a square within a golden rectangle and the rectangle that remains also will be a golden rectangle.

### Begin with a Rectangle

When designing a new piece of furniture, I typically start with a rectangle. That's because all furniture, tables, casework and even chairs will fit within a rectangle. Often, the first dimension of a rectangle is given. For example, the writing surface of a desk is typically 30" high. If you make it higher or lower, it becomes impractical for use. Dining tables also are 29" to 30" high; chair seats are usually 17" from the floor. (For more standard sizes look below and on the following page.)

To find the second dimension of the rectangle, I use a numbering system. For example, for a 30"-high table, multiply 30" x 1.618, which yields a table length of approximately 48 1/2".

After drawing the rectangle I scale the elements within the rectangle, such as feet, doors, drawers, carvings and mouldings. To help me find pleasing proportions, I'll often use Fibonacci numbers.

### Fibonacci Numbers

Fibonacci was an Italian mathematician who discovered the series of numbers that bear his name. Each number in the series is added to the previous number to find the next one in the series – 1, 1, 2, 3, 5, 8, 13, etc. Interestingly, the Fibonacci series can be found everywhere – from natural objects such as nautilus seashells to common, everyday items such as with 3" x 5" index cards.

Let's say you want to use ratios of Fibonacci numbers to figure out the size of a cabinet's feet. First, let's say the overall height of the cabinet is 84". Divide the height by a Fibonacci number. Which one? Take an educated guess. Determining which number to use comes with experience. My first guess would be to divide the number by 13, which means my cabinet's feet would be about



Even casework, such as this clock, with its complex mouldings and carvings, will fit within a golden rectangle, as shown by the blue line.

6 1/2" high. (Don't hesitate to add or subtract half an inch. While the numbers don't often deviate, they're also not set in stone.)

If this number looks good, great. Use another number to come up with the horizontal dimension (for example, multiply the foot's height by 1.618 to get about 10 1/2" – see the photo on page 75). If you feel this number is too large, simply divide the cabinet's height by a larger Fibonacci number to come up with a smaller height. It's a lot of work but it's worth it. Seventy-five to 80 percent of my furniture is designed using mathematics.

Fibonacci numbers also could

be used to size the top of a table. For example, using the ratio of 2:3, the width of the top of a tea table could measure 18.5" and the length is 27 3/4" (18.5 divided by 2 times 3 equals 27.75).

### Arithmetic Progression

If you've ever looked at a chest of drawers in which each drawer is the same size, you know how visually dull it can be. Drawers add much more visual interest to casework if they graduate, or become increasingly larger toward the bottom of the case.

However, the progression used must be in proportion to the size of the casework. If the drawers



progress too slowly, they'll appear to be the same size; if they progress too quickly, the lowest drawer will appear to be disproportionate to the top drawer.

One sure method for designing proportional drawers is to add the width of the drawer divider to the drawer height. The sum becomes the size of the drawer below in the series. For example, most casework that I build uses  $\frac{7}{8}$ " drawer dividers. By starting with the top drawer and adding  $\frac{7}{8}$ ", I can quickly and easily determine the drawer sizes in a chest or other type of casework.

Remember to enjoy the design process and use the information provided here as a guide; mathematical proportioning should enable your creative streak, not stifle it. As you draw and design a new piece, your critical eye should always make the final determination. **PW**

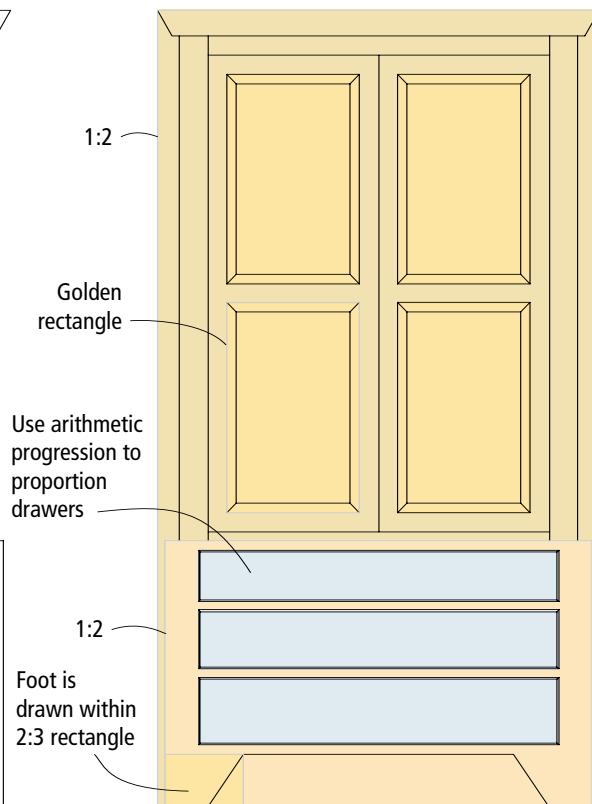
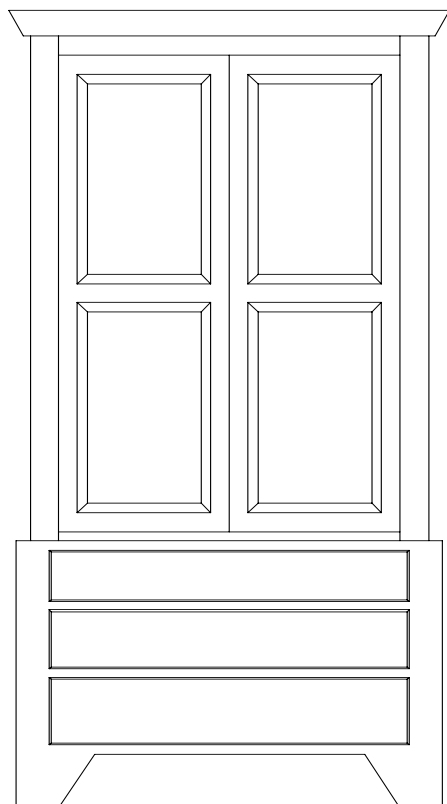

Pictured here is a typical drawing of a linen chest that I would create before building the piece. I've used all three proportioning methods outlined in this article: the golden rectangle, ratios of Fibonacci numbers and arithmetic progression.

The entire linen chest fits within a 2:1 rectangle. The door panels of the upper case are golden rectangles. The lower case is a 2:1 rectangle. Finally, the drawers are sized using arithmetic progression.

## THOUGHTS ON TABLE DESIGN

### TABLE HEIGHT

You don't have a lot of wiggle room here. Make sure your table height falls between 28½" and 30". A few sources say 32" is OK, but 30" is more common.

### APRON HEIGHT

Make sure each of your sitters has at least 24" of room between the bottom of the apron and the floor. This means that a 30"-high table with a 7/8"-thick top should have aprons no wider than 5½".

### OVERHANG

The distance from the edge of the top to the apron can vary. Between 10" and 18" is great.

### ELBOW ROOM

The amount of tabletop allowed for each place setting should be no less than 23"-wide. A roomier table will have 28" to 30".

### TABLETOP WIDTH

The standard width is between 30" and 34". A square table for four should be about 40" x 40". Six can be accommodated by a 60" x 30" top.

### CIRCULAR TOPS

To seat four, make your top 44" in diameter (34½" of edge space per person). To seat six people, make it 54" in diameter (28¼" per person).

### LEG TAPER

Tapered legs are a common feature of dining tables. Legs should taper to half their width at the floor. The taper should begin about 1" below the apron.

### SOURCES

For more information about standard furniture sizes and basic furniture construction, check out the following books:

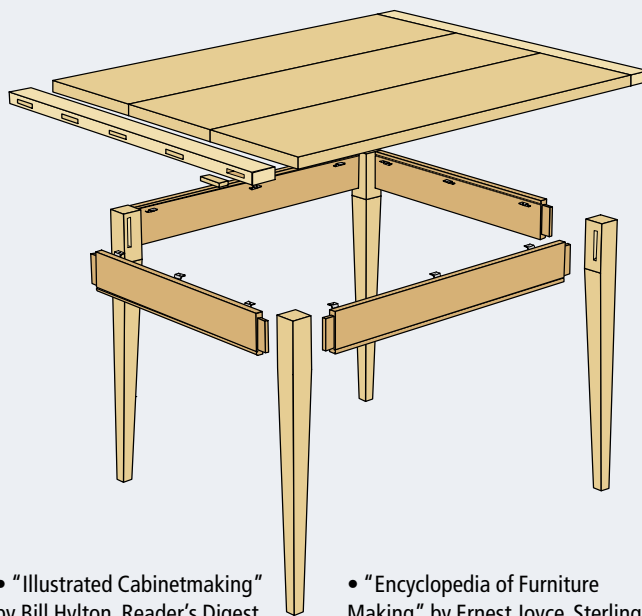

- "Illustrated Cabinetmaking" by Bill Hylton, Reader's Digest, Pleasantville, N.Y.
- "Measure Twice, Cut Once" by Jim Tolpin, *Popular Woodworking Books*, Cincinnati.

- "Encyclopedia of Furniture Making" by Ernest Joyce, Sterling Publishing Co. Inc., New York.
- "Cabinetmaking and Millwork" by John L. Feirer, Bennett Publishing Co., Peoria, Ill.

## HISTORY OF THE GOLDEN SECTION

Secret societies, Leonardo da Vinci, nautilus seashells, mating rabbits and pineapples: The golden section's history and reach is as fascinating as it is debated. Briefly, here's what we know:

Pythagoras, a Greek mathematician, born about 570 B.C., discovered the golden section (also called the divine proportion, golden ratio and golden mean). He founded and was head of a strict and secret philosophical and religious school in southern Italy. The pentagram, a geometric representation of the golden section, symbolized the Pythagoreans' brotherhood and they called it "Health."

Many credit Athenian architect Phidias with pioneering the use of the golden ratio when helping design the Parthenon. From Phidias we get the Greek letter Phi ( $\Phi$ ). Today, Phi stands for the irrational number used in the golden section, 1.61803333...

Later, Leonardo of Pisa (who called himself Fibonacci) introduced a math problem in his book "Liber Abaci," published in 1202: A pair of rabbits are put in a field where they can't escape and they

can't die. Suppose at the age of one month the female can produce another pair of rabbits (always one male and one female) and she continues to do so each month for an entire year. As each new female rabbit becomes 1-month old, she, too, produces another pair. How many pairs of rabbits will there be in a year? The solution, which involves a series of numbers (1, 1, 2, 3, 5, 8, 13, 21, ...), is now called the Fibonacci series.

The ratio between two adjacent Fibonacci numbers after three is 1:1.168 – the golden ratio. Today, many say this relationship can be found in art (Mona Lisa), architecture (Notre Dame), population growth, nature (sunflowers), music (scales), the stock market, the human face (Audrey Hepburn), the cosmos and even theology.

For information, check out Mario Livio's "The Golden Ratio" (Broadway Books) and visit:  
 • [www.mcs.surrey.ac.uk/Personal/R.Knott/Fibonacci](http://www.mcs.surrey.ac.uk/Personal/R.Knott/Fibonacci)  
 • [jimloy.com/geometry/golden.htm](http://jimloy.com/geometry/golden.htm)  
 • [goldenumber.net](http://goldenumber.net)

– Kara Gebhart

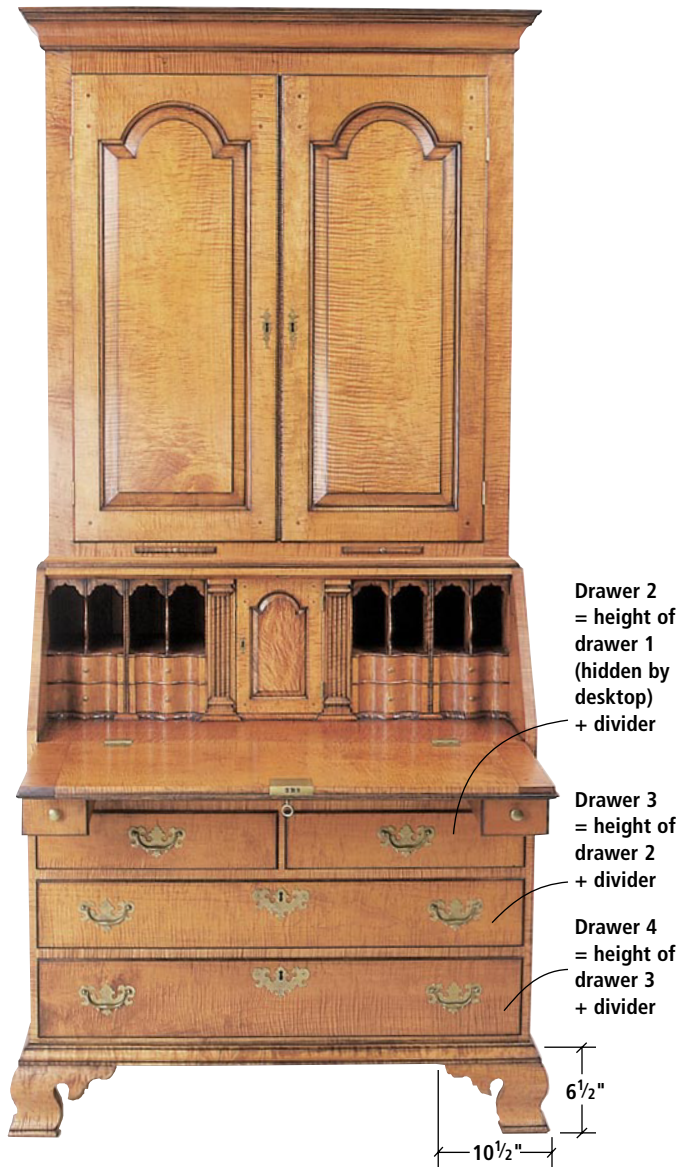

The drawers shown in this desk are an excellent example of arithmetic progression, and the feet are golden rectangles.

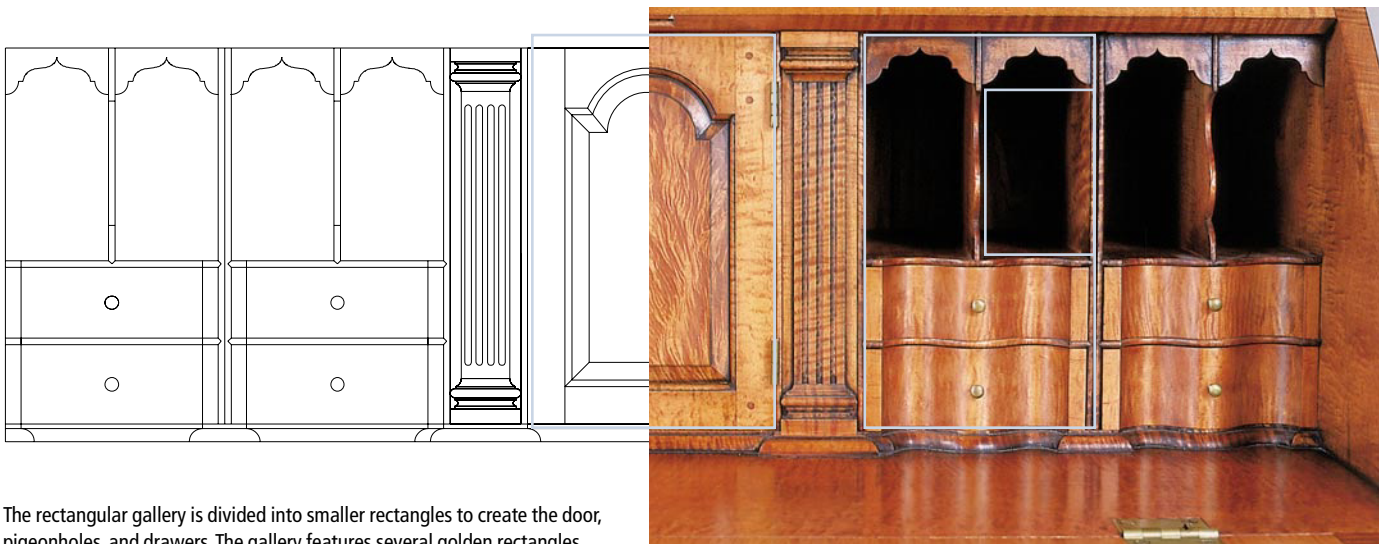

The rectangular gallery is divided into smaller rectangles to create the door, pigeonholes, and drawers. The gallery features several golden rectangles.



Photo by Al Parrish

# Portable CHISEL RACK

Keep your tools right where you need them.

**I**'ve seen, used and built a number of chisel racks, but none has ever seemed to suit me. Most of them are just a bit awkward.

And don't even get me started on the alternatives to a chisel rack: Chisel boxes and rolls take

up too much valuable space on your bench, and keeping the chisels in the bench's tool tray just adds to the clutter that collects there.

What most woodworkers need is a rack that holds all their chisels upright where they can grab

by Christopher Schwarz

---

*Comments or questions? Contact Chris at 513-531-2690 ext. 1407 or [chris.schwarz@fwpubs.com](mailto:chris.schwarz@fwpubs.com).*

them. They need a rack that protects the sharp tips. And they need to be able to move the rack off the bench when they're assembling big projects there.

After months of sketches, we're sure we've got the perfect rack. It does everything we want it to do and it can be hung anywhere in the shop (on a bench, a wall or even a cabinet side) thanks to a clever cleat.

And best of all, it's easy and fast to build with shop scraps.

### How Does Your Steel Measure Up?

The first thing to do is to measure a few dimensions on your chisels with a ruler and a dial caliper.

Find the thickest part of your thickest blade. Add  $\frac{1}{32}$ " to that measurement and that will be the thickness of all the spacers between the chisels.

Next measure the length of all of your chisels' blades and find the longest one. That length is the width of all of your spacers. (Yes, I do mean width. You want the grain of the spacers to run in the same direction as the front and back pieces.)

Then measure the width of each chisel (don't assume that what is marked on the tool is correct). Add  $\frac{1}{16}$ " to each measurement and that will determine the distance between each spacer. Take these measurements to the saw and rip a small piece of scrap to each of these widths. Mark them with their width. These scraps will help you place your spacers during assembly.

The spacers between each tool are  $2\frac{3}{8}$ " long. This might seem like a lot, but it allows you to grab any chisel without rapping your knuckles against its neighbor. Most chisel racks I've seen place the tools' handles too close together so you're always fishing out the specimen you need.

### A Chisel Lasagna

This rack is essentially four layers of wood sandwiched together. You glue the spacers between the front and back pieces, then you screw a cleat to the back of the rack to hang it.

The stop piece, which is located below the spacers, accomplishes two things: First, it keeps all the chisels at the same height. Second, it prevents you from destroying your rack.

Let's say you built the rack without the stop. Someday, you're going to accidentally drop something on one of your chisels in the rack. The chisel's socket will then wedge into the rack, splitting apart all your work. So spend the extra five minutes to cut and install the stop.

Now that you know the size of the spacers, the space that needs to go between them and the lengths of the blades, you can calculate the dimensions of your front and back pieces (don't forget to add some width for the stop piece). You are ready to begin milling your wood.

Plane down all the pieces you'll need for the rack, then rip and crosscut all your pieces to size. The first step is to attach the stop piece to the back. But before you attach the stop, cut a 45° chamfer on one long edge that measures  $\frac{3}{8}$ " x  $\frac{3}{8}$ ". The chamfer makes it easier for dust that gets into the rack to fall out. Then glue the stop in place on the back.

Now nail one of the end spac-

ers in place. Remember those scraps you ripped to width after you measured the width of your chisels? Get them. Place them between your spacers and make sure everything fits to your satisfaction. Now glue and nail the spacers (but not the scraps) in place using  $\frac{1}{2}$ "-long brads.

When that's complete, glue the front piece to the spacers. You're almost done. Clean up all



A dial caliper is handy for checking your chisels' dimensions. Measure the width of each blade, add  $\frac{1}{16}$ " to each measurement, then rip a scrap piece to that width, which will come in handy during assembly.



Use those scrap pieces to lay out the location of the spacers on your back piece. When everything fits, glue and nail the spacers in place.

The chamfer on the stop piece and the slightly narrow front piece allow dust to escape the rack easily.

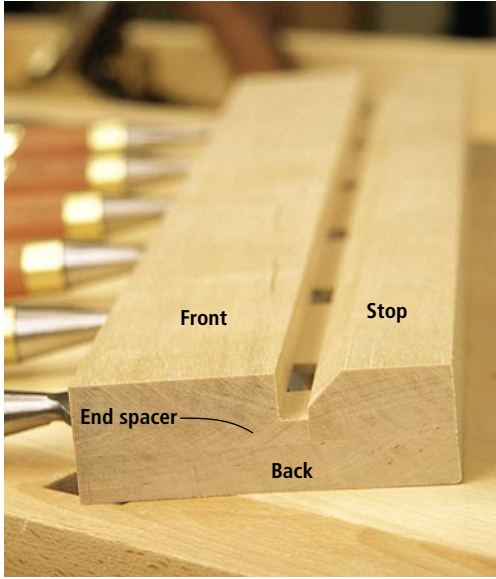

four edges of the assembled rack. Run the bottom edge over your jointer (or clean it up with a hand plane), then rip the rack to width on your table saw to clean up the top edge. Finally, crosscut the ends to tidy things up.

### A Clever Cleat

This rack hangs anywhere using two cleats that interlock thanks to a  $\frac{3}{8}$ "-deep x 1"-wide rabbet on each part. You want the fit between the two cleats to be firm. Here's how to do it right: Cut the rabbet on one long edge of each cleat so it's just a touch shy of  $\frac{3}{8}$ " deep, maybe by a few thousandths.

Screw one of the cleats to your bench, shop wall or cabinet. With the other cleat, plane or sand the rabbet at the ends so that the surface is a very gentle and subtle curve. Break the sharp corners of the joint using a block plane or sandpaper, which will make nesting the two cleats easier.

Now screw (but don't glue) this cleat to your rack and give it a try. If the fit is too tight, remove the cleat and thin down the rabbet a bit more. If the fit is too loose, remove the cleat and make a few passes with a plane on the area where the cleat attaches to the rack. This will tighten up the fit.

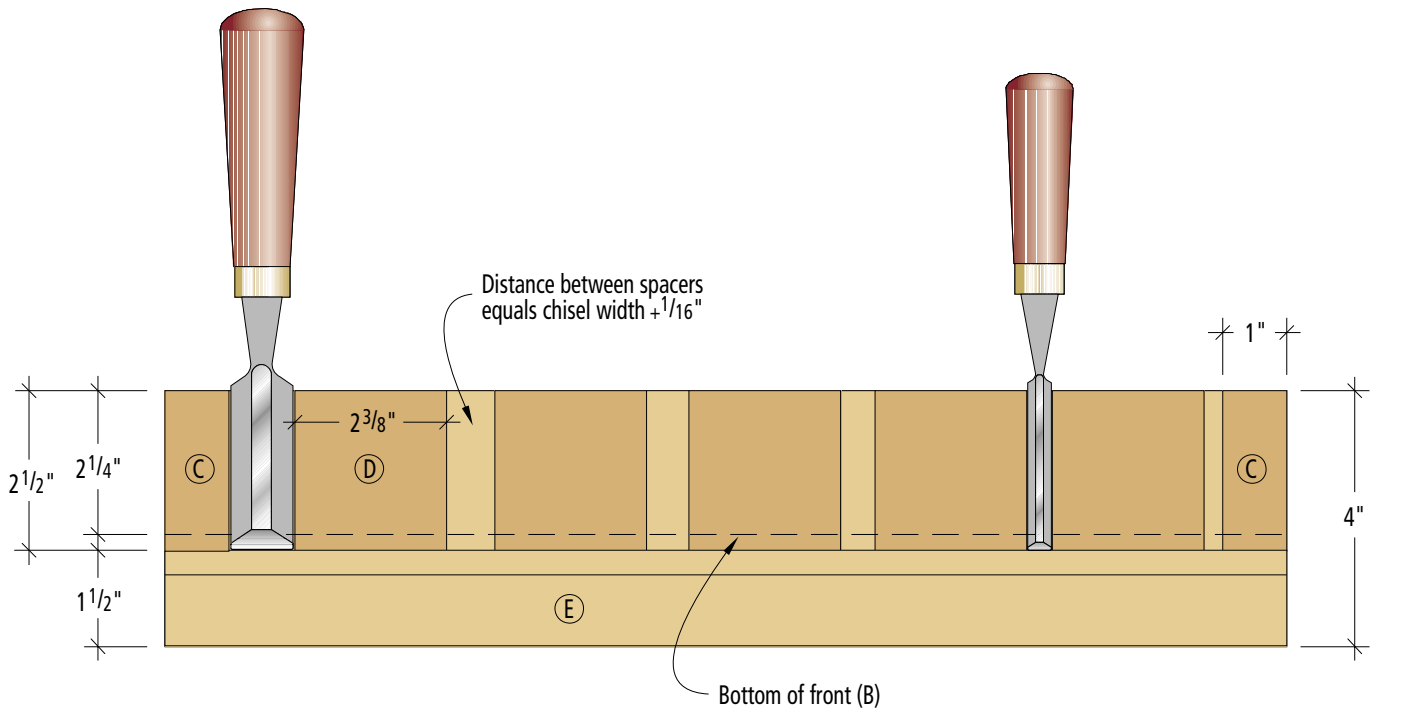

**Elevation**

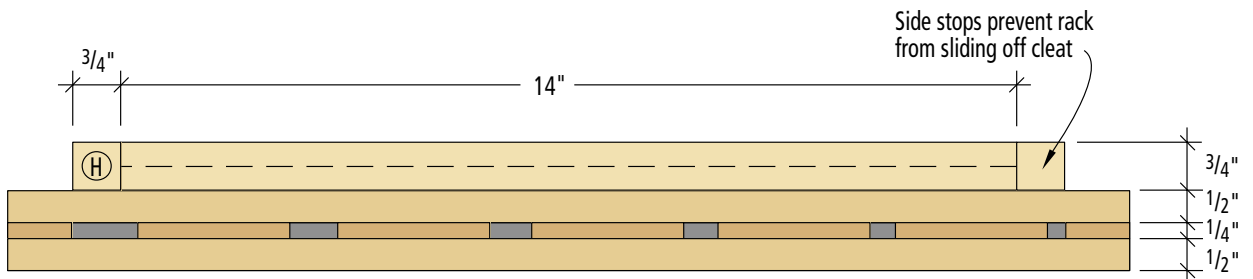

**Plan**

Once you're satisfied, glue and nail the two side stops on either end of the cleat that's attached to the rack. The side stops will prevent you from pushing the rack off its cleat.

Sand, plane or scrape the surfaces of the rack and add a clear finish. Finish your rack with whatever you used on your workbench. For me it's a wiping varnish comprised of three parts varnish and one part paint thinner.

Since I've installed this rack I've been astonished at how many trips it has saved me to hunt down the chisel I'm looking for. This rack's a keeper. **PW**



A rabet plane or shoulder plane makes quick work of fitting the cleats together. You want the cleat to fit tightly in the middle and a bit looser on the ends. This will allow you to pivot the chisel rack on and off its mating cleat.

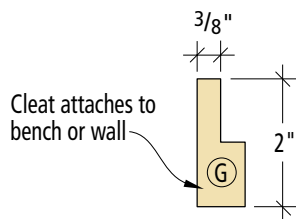
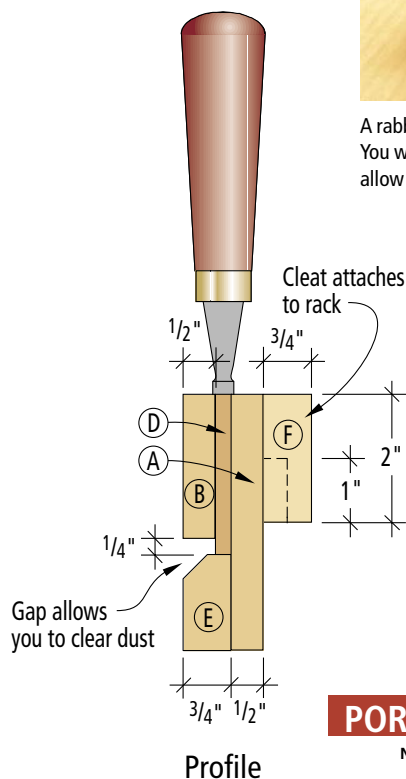

## PORTABLE CHISEL RACK

	NO.	LET.	ITEM	DIMENSIONS (INCHES)			MATERIAL
				T	W	L	
<input type="checkbox"/>	1	A	Back	1/2	4	17 3/4*	Birch
<input type="checkbox"/>	1	B	Front	1/2	2 1/4	17 3/4*	Birch
<input type="checkbox"/>	2	C	End spacers	1/4	2 1/2†	1	Birch
<input type="checkbox"/>	5**	D	Spacers	1/4	2 1/2†	2 3/8	Birch
<input type="checkbox"/>	1	E	Stop	3/4	1 1/2	17 3/4*	Birch
<input type="checkbox"/>	1	F	Cleat for rack	3/4	2	14*	Birch
<input type="checkbox"/>	1	G	Cleat for wall or bench	3/4	2	13 1/2*	Birch
<input type="checkbox"/>	2	H	Side stops	3/4	3/4	2	Birch

KEY: \* Actual measurement depends on how many tools go in the rack.

\*\* Number of spacers depends on the number of tools.

† Thickness of spacers depends on thickness of tools.

## CHOOSING GOOD CHISELS

The chisels shown here are the new American-pattern Ashley Hles chisels available from Tools for Working Wood ([toolsforworkingwood.com](http://toolsforworkingwood.com) or 800-426-4613; \$100.82 for a set of six). The steel in these chisels did really well during a test performed by the magazine editors in our February 2001 issue. If you're in the market for chisels, here are the other brands that fared well:

### • Marples Blue Chips

These are good all-around chisels. They're inexpensive and hold their edge pretty well. Available at any woodworking specialty store or catalog. A set of five costs about \$45.

### • Craftsman #36859

While these might have the oddest-looking handle on the market, the steel is surprisingly good. [Craftsman.com](http://Craftsman.com) or 800-377-7414. A set of five costs \$29.99.

### • E.C.E.

German chisels with a horn-beam handle. Refinish the handle and you have a top-notch tool. [Ecemmerich.com](http://Ecemmerich.com) or 800-724-7758. A set of six costs \$108.

### • Two Cherries/Hirsch

Excellent steel and decent handles are the good points. Price and the amount of lapping these tools require are the bad points. [Highlandhardware.com](http://Highlandhardware.com) or 800-241-6748. A set of four costs \$79.99.

### • Woodworker's Supply German Bevel-edge Chisels

Once you refinish the hornbeam handles on these bargain tools, you'll have a fine and durable set of chisels. [Woodworker.com](http://Woodworker.com) or 800-645-9292. A set of four costs \$27.99.

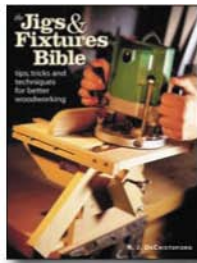

#70491-6 ~~\$24.99~~

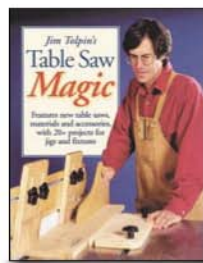

#70429-6 ~~\$24.99~~

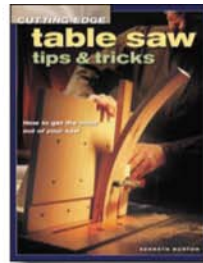

#70569-9 ~~\$24.99~~



#70584-8 ~~\$24.99~~

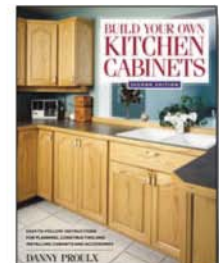

#70626-7 ~~\$24.99~~

Join **WoodWorker's Book Club** and

**CHOOSE 3 BOOKS**  
with a 4th Book for just

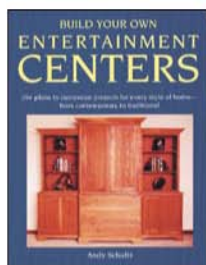

#70354-6 ~~\$22.99~~

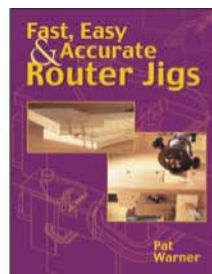

#70427-0 ~~\$24.99~~



#70521-0 ~~\$24.99~~



#70555-8 ~~\$24.99~~

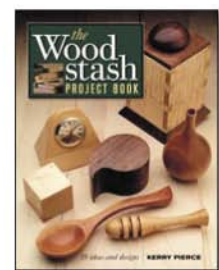

#70540-0 ~~\$24.99~~



#70493-2 ~~\$24.99~~

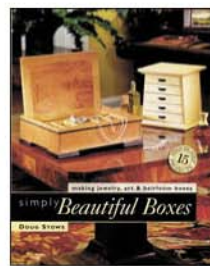

#70431-2 ~~\$21.99~~

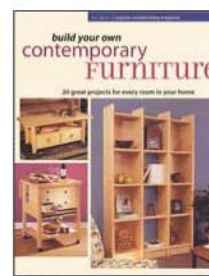

#70551-7 ~~\$24.99~~



#70533-5 ~~\$26.99~~

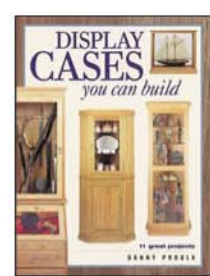

#70547-5 ~~\$24.99~~

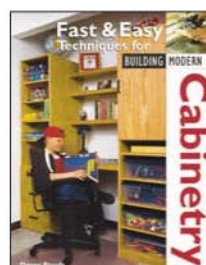

#70466-8 ~~\$22.99~~

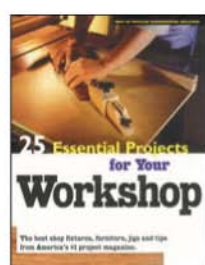

#70472-6 ~~\$22.99~~

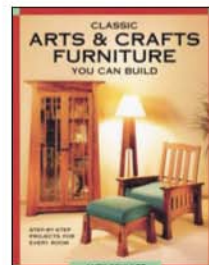

#70422-1 ~~\$24.99~~

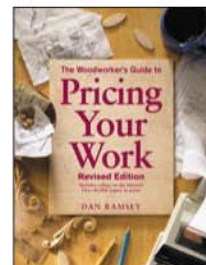

#70516-0 ~~\$21.99~~

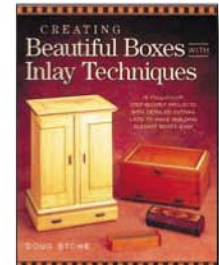

#70368-6 ~~\$24.99~~

All books are softcover unless marked hc. Prices shown are publishers' list prices.

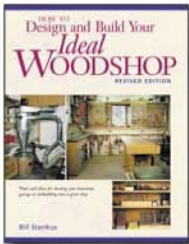

#70522-8 ~~\$27.99~~

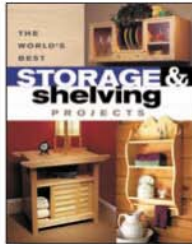

#70587-1 ~~\$24.99~~

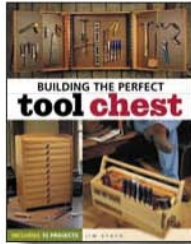

#70598-8 ~~\$24.99~~

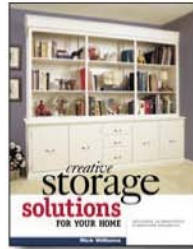

#70534-3 ~~\$24.99~~



#70585-5 ~~\$24.99~~

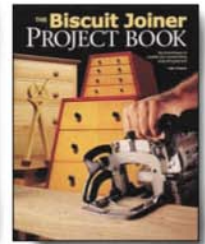

#70531-9 ~~\$26.99~~

# FREE

**\$9.99** plus shipping & handling

Plus get a **FREE** Gift

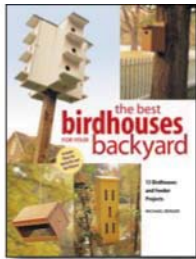
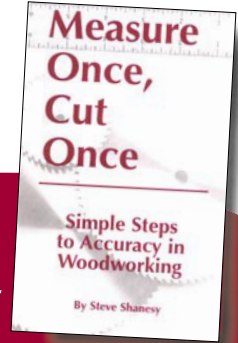

#70520-2 ~~\$24.99~~

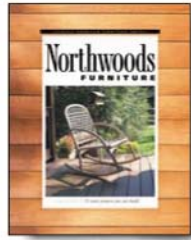

#70500-4 ~~\$24.99~~



#70492-4 ~~\$24.99~~

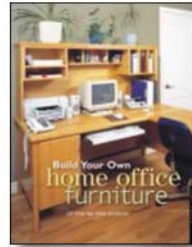

#70489-0 ~~\$26.99~~

Uncover the secrets to getting exact lengths, perfect angles, and snug joints every time with this guide from *Popular Woodworking* Editor Steve Shaney.

A **\$3.95** value, yours **FREE** with membership!

### How the Club Works

- **FREE CLUB NEWS** About every 4 weeks (14 times per year), you'll receive the *NEWS*, featuring a Main Selection and 100 or more of the newest and best woodworking instruction books.
- **EASY ORDERING** Simply return your Selection Card or visit the website by the specified date, indicating whether you want the Main Selection and/or any additional books. After this joining offer, if you prepay for your selection(s), shipping and handling is FREE! (If you don't have time to respond, we'll send the Main Selection automatically.)
- **RETURN PRIVILEGE** If the *NEWS* is delayed and you ever receive the Main Selection without having 10 days to notify us, you may return the selection at Club expense.
- **NO-OBLIGATION MEMBERSHIP** You have no obligation to buy any more books; you're just agreeing to try the Club for 9 months. After that, you may cancel at any time. Each time you buy a book, your membership will be renewed for 6 months from the purchase date.

**WOODWORKER'S** BOOK CLUB  
PO Box 9274  
Central Islip, NY  
11722-9274

**1-800-448-0912**

Call TOLL FREE Monday-Saturday,  
9a.m.-7p.m. M-F 9a.m.-6p.m. Sat EST  
[www.WoodWorkersBookClub.com](http://www.WoodWorkersBookClub.com)

Join online @ [www.WoodWorkersBookClub.com](http://www.WoodWorkersBookClub.com) for an even larger book selection!

## MEMBERSHIP SAVINGS CERTIFICATE

**YES!** I want to join WoodWorker's Book Club! Please send me:

My 1st Book **FREE**    my 2nd Book **FREE**    and my 3rd Book **FREE**    with my 4th Book for \$9.99    Plus my **FREE** Gift

# [ ] [ ] [ ] [ ] - [ ] # [ ] [ ] [ ] [ ] - [ ] # [ ] [ ] [ ] [ ] - [ ] # [ ] [ ] [ ] [ ] - [ ] # 8 0 3 6 0 - 1

VISA/MasterCard/AmEx Orders Call **TOLL FREE 1-800-448-0912**  
9a.m.-7p.m. M-F 9a.m.-6p.m. Sat EST

I'm enclosing \$9.99 plus \$7.93 shipping & handling, for a total of just \$17.92.

Check enclosed (or) Charge my  VISA  MasterCard  AmEx

Acct. # \_\_\_\_\_ Exp. \_\_\_\_\_

Signature \_\_\_\_\_  
(REQUIRED OF EVERYONE)

I have read How the Club Works and understand I have **NO OBLIGATION** to buy any more books.

Name \_\_\_\_\_  
(PLEASE PRINT)

Address \_\_\_\_\_

City \_\_\_\_\_ State/Prov. \_\_\_\_\_ ZIP/PC \_\_\_\_\_

Offer good for new members in U.S. and Canada only. In OH, NY, CO, MA and MI, please add applicable state tax. In Canada provide a street address and remit in U.S. funds; enclose \$10.33 s&h and \$1.42 GST for a total of \$21.74. One membership per household. Allow 3-4 weeks for delivery. The Club reserves the right to approve all applications and may cancel membership at any time.

Mail today to: **WOODWORKER'S BOOK CLUB** • PO Box 9274 • Central Islip, NY 11722-9274

KAM03PW





Photo by Aaron Allred

# MUSIC CABINET

Simple joinery and common materials can go a long way.

**T**he day finally came when I decided to organize the bluegrass CDs and albums that had taken over virtually every horizontal surface in our living room. I searched local stores and the Internet and found a number of commercial CD racks on the market, but none that actually complemented our décor.

My wife and I knew what we wanted: Something refined but not too formal, and it had to store about 120 CDs and albums. While we like listening to our music, we don't get any particular pleasure from staring at rows of jewel cases while we entertain, so a door was a definite requirement.

The cabinet shown is our compromise. The CDs are stored in the upper section in nifty little spring-loaded CD racks that I ordered online. To eject a CD, just push it inward and it pops out into your hand. Albums are stored below, and I included a small cubby at the top for boxed sets, empty jewel cases and the rest of the stuff that tends to pile up around electronics equipment.

## **Design and Construction**

The cabinet is fairly simple in appearance, so I took the time to make a hand-carved door pull. I like the way this small detail contrasts with the larger swooping curves of the corner posts.

And because the door pull literally needs to be grabbed onto, it is a great opportunity to involve the viewer with the piece in a more thoughtful way. Inevitably, people who see the cabinet for the first time step back and admire the whole thing, then they lean in and carefully touch the handle to appreciate it up close.

My schedule doesn't allow a lot of time for me to work on furniture for my own home (we're all familiar with the shoemaker's barefoot children), so I needed to build the cabinet in a simple and relatively quick way. Using birch plywood allowed the case to come together quickly, and the solid walnut corner posts can be quickly band-sawn into a dramatic curved shape (essentially an oversized corbel, for those familiar with Arts & Crafts design elements).

by Chris Gleason

---

*Chris Gleason designs and builds contemporary furniture and cabinetry for homes and commercial spaces in Madison, Wisc. You can see more of his work at [interestingfurniture.com](http://interestingfurniture.com).*

Biscuits and pocket screws keep assembly simple, and the latter even help minimize the number of clamps you'll need for gluing up the case.

### Mill the Corner Posts

Fabricating the corner posts is straightforward. I like to try to get all four posts from a single board to ensure that they match in terms of color and figure, especially in a species like walnut that varies so much from one board to the next.

I established the overall dimensions of the piece by measuring the spot it was to occupy, then I made a full-sized drawing to refine the proportions. I sketched some different shapes for the corner posts, incorporating different curves, tapers and flares. To make a template, I transferred the final shape to a 1/4" piece of plywood. We've provided a scaled pattern on page 85 for you to make your own template. Transfer the pattern to some plywood, then care-

## MUSIC CABINET

NO.	ITEM	DIMENSIONS (INCHES)			MATERIAL	COMMENTS
		T	W	L		
4	Corner posts	1 3/4	4	53	Walnut	Nested pieces
1	Back panel	3/4	12	48	Birch plywood	
2	Side panels	3/4	12 1/2	48	Birch plywood	
1	Top panel	3/4	18 3/4*	24 1/2*	Birch plywood	
4	Shelves and bottom	3/4	12 3/8*	12	Birch plywood	
2	Door stiles	3/4	1 3/8	48	Walnut	
3	Door rails	3/4	1 1/2	9	Walnut	
2	Door panels	1/4	9 3/4	22 11/16	Birch plywood	
2	Top edging	1/4	3/4	25	Walnut	
2	Top edging	1/4	3/4	18 3/4**	Walnut	
4	Shelf edging	1/4	3/4	12	Walnut	
2	Vertical dividers	3/4	6	20 5/8	Walnut	
1	Divider trim	1/4	1 1/2	20 5/8	Walnut	

\*Sizes do not include 1/4" edging

\*\*Length reflects butt-joint edging, not mitered.

fully band saw the shape and clean up the rough edges with a spindle, sander or spokeshave.

Use the plywood template to transfer the pattern to 8/4 walnut boards, thickened to 1 3/4", and jointed on both edges. Trace the template with its flat (inside) edge against one jointed edge of the board, then flip the template over and nest a second post on the same board. Use your band

saw to cut the posts to rough shape (cutting slightly wide of the line), then clean them up on the sander.

One way to keep the shapes uniform is to clamp or tape two pieces together and sand them both at the same time. It also lessens the time I spend sanding.

### Prepare the Plywood Panels

Once the posts are shaped, cut out the plywood panels for the cabinet parts. I typically rip the plywood into strips of the necessary widths and crosscut them on a table-saw sled for accuracy, safety and speed. To avoid tear-out, feed slowly and use a sharp blade.

One drawback to using plywood is the "exposed core" edges. Before assembling anything, I hide the exposed edges using 1/4" edging strips. The birch top gets edged on all four sides, while the shelves and bottom are edged only on the front. I used walnut edging to add contrast to the piece, gluing the edging in place with painter's tape. In my opinion this is the least clamp-intensive (and easiest) method to attach edging, but if you've got the clamps, they're still a good idea.

I edged the sides of the top, cut them flush with the front and back edges, and then edged the front and back edges. This leaves

the butt-jointed edging on the sides, making it less visible. You could also miter these joints for a more refined appearance. The shelves and bottom are simply edged, then trimmed to length and planed flush.

### The Side Assemblies

With the exception of a couple of holes, it's time to assemble the sides. While the sides and back are attached to the posts using biscuits, I use pocket screws to attach the top, bottom and shelves. It's easier to drill the pocket holes in the sides (to attach the top) before assembling the sides, so on the inside face of the two side panels, drill two pocket holes at the top edge about 1" in from each edge. While you've got the drill out, you might as well drill the pockets in the shelves and bottom as well, using the same spacing as on the sides.

Assembling the cabinet is easiest when working in stages: You will first assemble the cabinet sides by sandwiching a plywood panel between two walnut corner posts. Then glue the back between the sides. Finally, add the shelves, top and bottom.

I use biscuit joints to attach the plywood panels to the posts because it makes a strong, straight-

After transferring my pattern to the leg blanks, it's time to go to the band saw. A slow, steady feed rate provides a fairly smooth cut line. Remember to cut slightly wide of your mark, but keep it as tight as you can to reduce the amount of time you have to spend cleaning up the rough edges.



## SOURCES

### Rockler

800-279-4441 or rockler.com

- 1 • Amerock non-mortising hinge #31495, \$5.99/pair
- 1 • Magnetic door catch #30546, \$2.99
- 4 • CD ejecting storage racks #92908, \$6.99/pair

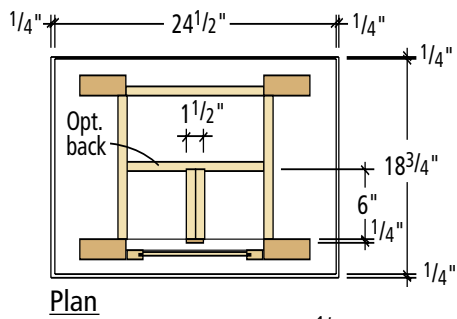

Plan

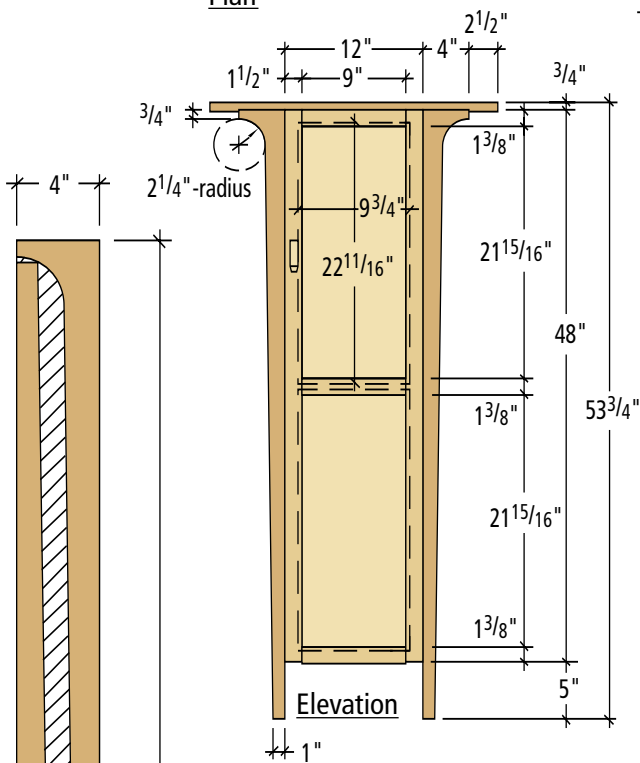

Elevation

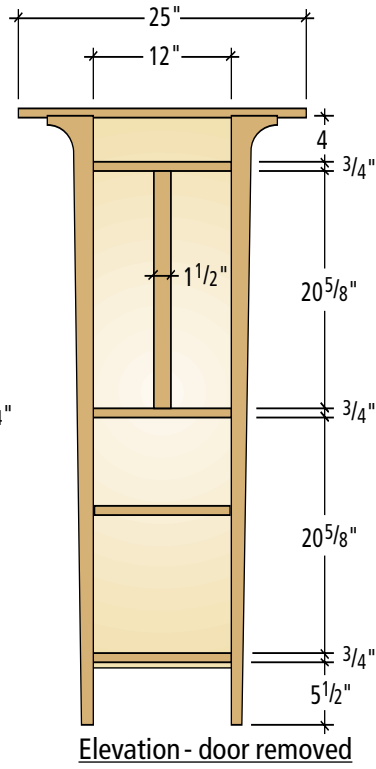

Elevation - door removed

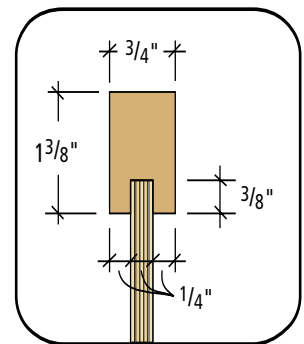

Top and bottom door rail

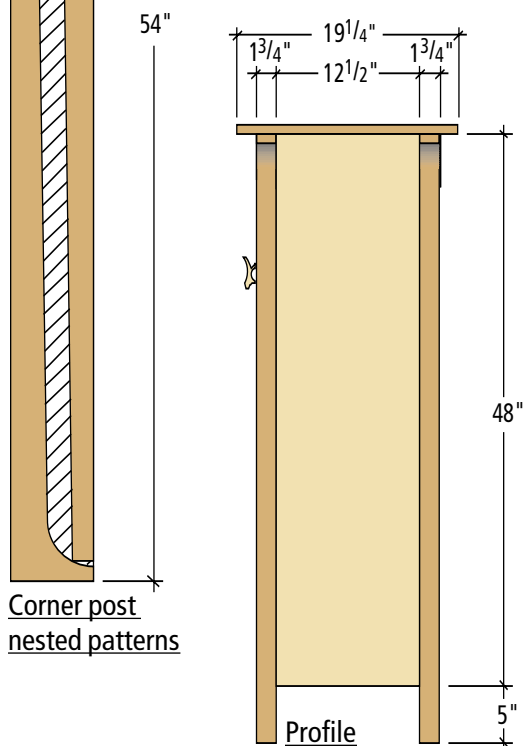

Corner post  
nested patterns

Profile

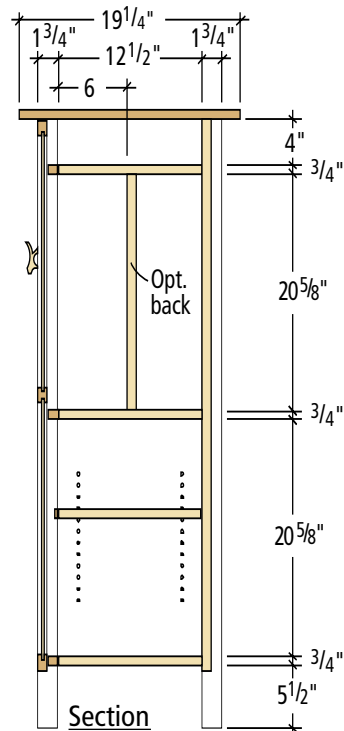

Section

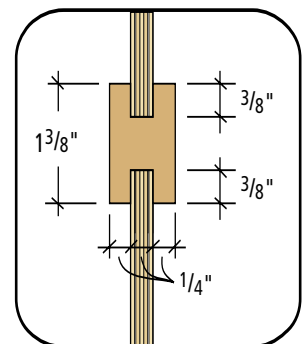

Middle door rail



With the back glued and clamped, I can go ahead and attach the top, then the bottom and permanent shelves. This photo lets you see the pocket screw holes drilled in the shelves. Once you have the shelf in the right location, clamp it to hold it in place, then drive the screws home.

forward joint, and biscuits allow easy alignment of the parts.

All the panels align flush to the inside edge or corner of the posts, making accurate biscuit alignment critical, but still fairly simple. To mark the biscuit slot locations, I dry-clamp the side assemblies first, holding everything tight and in place. On a joint of this length, I use about five biscuits, spaced a hand's width apart. The distance between the biscuits isn't critical, but make sure that your marks run evenly across the posts and the panel and that they're easily visible.

Unclamp the sides, then clamp the rear posts in place on either side of the back panel, again holding the plywood flush to the inside of the posts. Mark locations

for the back biscuits on the two edges (so they won't meet or interfere with the other slots), interspersing these slots between the slots for the side biscuits.

Remove the clamps and cut the slots for all the biscuits. By using the biscuit jointer with the fence set to cut in the center of a  $\frac{3}{4}$ "-thick panel, all the slots can be cut using the same setting by working from the inside surfaces.

After cutting the slots, it's not a bad idea to dry-fit the parts with biscuits in the slots to make sure the slots went deep enough and are properly aligned.

### Assembling the Cabinet

The first step is to glue the side panels between the posts. When you're gluing up the sides, make



Gluing the plywood panels into the grooves in the door frames feels weird if you've ever done frame-and-panel doors with solid panels. You're not supposed to glue solid panels, but it's important here. You can see at the bottom of the photo that I let the groove run through on the stiles. It's not visible after assembly, but it does make adding the biscuit to the joint a little tricky.

sure you have a clean, damp paper towel on hand to immediately wipe away glue squeeze-out. The veneer used in plywood is usually very thin, so if you have to sand a lot to remove excess glue you run the risk of burning through the veneer. Just like my old high school wrestling coach used to tell me, the best way to get out of a half nelson hold is to not get into one to begin with.

When the side assemblies are dry and sanded flush on the inside edges, it's time for you to glue that back panel between the two side assemblies.

While this is drying, attach the top with pocket screws through the holes previously cut in the side panels. Just center the top to split the overhang evenly side-to-side and front-to-back. If you want to plug these pocket holes, now's the time. Otherwise leave them as is because they're hardly visible.

Next, attach the upper shelf with pocket screws. To get the shelf spacing accurate, I simply rip scrap plywood into two 4"-tall spacers and insert them between

the top and the upper shelf.

The bottom is next. Rather than hold the bottom flush to the height of the sides, I hold it up  $\frac{1}{2}$ " from the bottom edge to make aligning the door easier.

To install the middle shelf, you can either measure and mark to evenly space the two openings, or just make two more  $\frac{1}{4}$ " plywood spacers to make it even easier. The shelf dividing the lower section is left adjustable to meet your needs.

### Building the Door

While this appears to be a fairly traditional frame-and-panel door, it is somewhat unconventional in the way it goes together. Using a plywood panel is common in doors like this, but I take advantage of the plywood's dimensional stability and glue it into the frame on all sides. This creates an extremely durable and rigid door. To add some alignment and strength at the corners and center rail, I add a #0 biscuit.

Start by milling the door stiles and rails to  $1\frac{3}{8}$ " wide x  $\frac{3}{4}$ " thick. Cut the pieces to length (two 48"

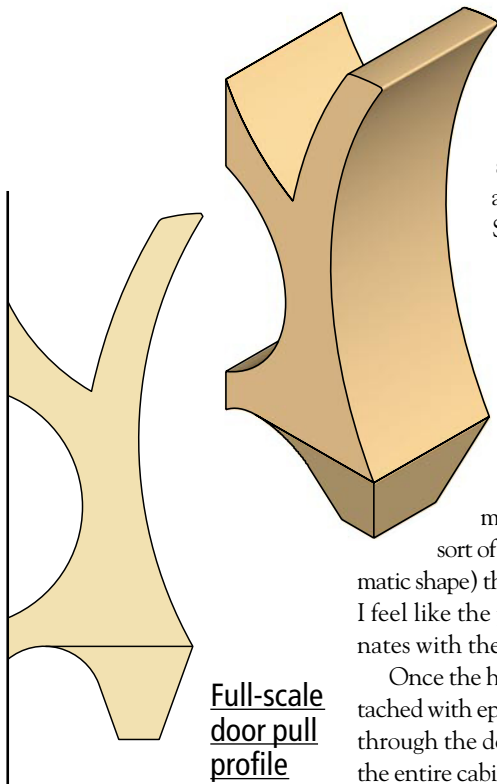

**Full-scale door pull profile**

stiles and three 9" rails), then cut a 1/4"-wide x 3/8"-deep groove, centered on the inside edge of all the pieces. For the stiles, you may want to stop the groove short of the top to hide the groove from view. The middle rail will need a groove milled on its other side as well because it gets a panel recessed into it on both its top and bottom edges.

Make sure the plywood panels fit in the grooves snugly; a sloppy fit will undermine this method of assembly. Once the plywood panels are cut to size, the door can be dry-fit and glued up.

### Finishing Touches

Although I could've bolted on any number of store-bought door pulls, I'm glad I took the time to design one that works for this particular cabinet – it's a small detail that goes a long way. I build lots of pulls like this for cabinet doors, drawer fronts and jewelry box lids, and I always start by milling eight or 10 oversized blanks in my wood species of choice. This allows me to experiment

with different shapes and refine as I go along. Sometimes I end up using the first one I cut, but I generally prefer the later ones in the series because as I work, I identify a particular design element (usually some sort of curve or other dramatic shape) that I play with until I feel like the pull really coordinates with the piece.

Once the handle has been attached with epoxy and/or a screw through the door stile, I varnish the entire cabinet inside and out.

### Adding Storage

Installing the CD racks requires some methodical work because they're sold in left- and right-hand pairs. It took two pairs per space to adequately fill the height (the racks are 12 3/4" tall), and with four pairs in front of you, they could easily get mixed up. You'll also need to trim the bottom off half of them on the band saw or radial arm saw to fit the space. You may have noticed that the CDs don't fill the cabinet front-to-back. To allow enough space for my albums below, I ended up with some wasted space, though I'm sure you can think of something to store secretly behind your CD collection.

The racks are designed to screw to cabinet sides, so our cabinet needs a vertical divider running up the center to mount the center racks. The divider is 1 1/2" thick x 6" wide x 20 5/8" long. It's made by gluing two 3/4" pieces of plywood together, then adding a 1/4"-thick walnut trim piece to hide the plywood edge on the front.

I fasten the divider into the cabinet with pocket screws, drilling

the pocket holes at the top and bottom of the center divider. The pocket hole screws get covered by the CD racks, so there's no need to plug them.

Because you've now got a 6"-wide space to work in, screwing in the racks becomes a tight procedure. The best solution I've found was to borrow a friend's close-quarters right-angle drill, which convinced me to add one to my power tool wish list.

### Hanging the Door

Mounting the door is the last step. I use a non-mortising, wrap-around hinge because it doesn't require routing or chiseling out a mortise, and because it offers a slight degree of adjustability by featuring elongated slots instead of just round holes.

First I screw the top hinge to the back of the door. Then I place the door in its opening. I use an X-acto knife to mark the top and

bottom positions of the hinge on the inside of the walnut corner post and note how far in or out the hinge falls relative to the front edge of the post.

Open the door, eyeball the marks as well as both the fore and aft door positions, and screw in the hinge. If the door closes smoothly, put on the bottom hinge in the same manner. Any discrepancies in the position of the door can be adjusted by moving the screws up, down, left or right in the hinge's slots.

A simple magnetic catch on the top left corner of the door keeps things tight.

I consider this cabinet to be a good example of how a refined, durable piece can be constructed with relatively simple techniques. It is practical, elegant and gratifyingly straightforward. And I've finally got a fitting home for my ever-expanding collection of bluegrass music. **PW**



Installing the CD racks is tight work, so the close-quarters right-angle drill came in very handy. Too bad I had to borrow one, but a trip to the tool store will fix that shortly.



For the serious  
woodworker and professional.

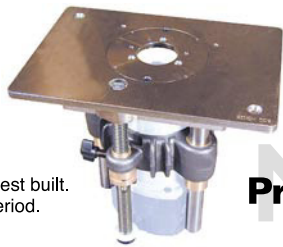

The best built.  
Period.

**ProLift™**  
28

**Router Adjustment System (model PL1002)**

Perfect for Porter-Cable 7518, 7519 routers and 4.2" diameter fixed base router motors (except plunge routers). Fits 3.5" dia. and smaller fixed base motors with adapters. Cast iron plate and housing. Change and adjust bits from above the table. Zero up/down backlash.

**ProTop**  
COMPLETE

(model FTB400)

Looking for it all? Then the FTB400 is for you. **ProTop Complete** includes our best-selling **ProTop Standard** router table, 36" **ProFence**, and **ProTop Cabinet**. (Shown with optional Feather-Loc featherboards, Power-Loc remote power switch, Drawer Bank, and Cab-Loc mobile leveling system.)



**FREE CATALOG!**  
Mention Code PW9

MADE IN  
USA

benchdog.com

To Order Call 800.786.8902

CIRCLE NO. 106 ON FREE INFORMATION CARD.

The **BLUE** Mark of Quality.



**POCKET HOLE SYSTEMS™**

Quality tools,  
education,  
service and value.

Expect this and  
more from **KREG**,  
the leader in Pocket  
Hole technology.

Kreg Jig® ProPack

**A better way to join wood.**

**Faster...** No waiting for the glue to dry.  
**Stronger...** Screws put unmatched clamp pressure on the joint line.  
**Simpler...** Drill pocket holes in only one workpiece. Align for assembly with a single clamp.  
**Better!** Faster assembly, stronger joints, fewer headaches. Give it a try today!

Two simple steps to wood joinery . . .

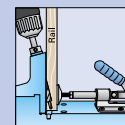

Drill pocket holes.

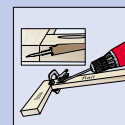

Drive screws.

www.kregtool.com



800.447.8638

CIRCLE NO. 127 ON FREE INFORMATION CARD.



www.amazon.com/dewalt

See over 1,300 DEWALT tools online.

The DEWALT 13" thickness planer provides best in class surface finish through a one of a kind three knife cutter head - even in hard to plane figured woods.

- Three knife cutter-head for superior surface finish
- Fan-assisted chip ejection system aids in the removal of debris
- Two-speed gear box, 96 or 179 cuts per inch for the finest finish
- Automatic carriage lock minimizes the movement that causes snipe
- Solid 19-3/4" cast aluminum base provides for rigidity



#DW735  
13" Thickness Planer



\*We will match our competitors price plus beat it by 10% of the difference. Find out more at www.amazon.com/price-match.

Call for your FREE Tool Crib catalog  
1-800-635-5140

amazon.com  
tools & hardware

CIRCLE NO. 103 ON FREE INFORMATION CARD.

**All-In-One Clamp**

"E. Emerson Tool Co. has done a nice job of refining the tool and adding useful accessories."

Performance - Five Stars

POPULAR WOODWORKING, Oct. 2003

- Locks quickly and positively
- Built-in inch & centimeter scales for easy setups
- Makes a great fence for your drill press, band saw or router

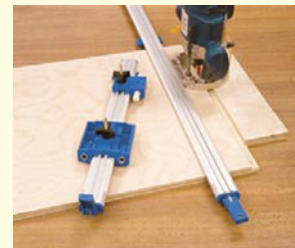

**E. Emerson Tool Co.**

Go to: allinoneclamp.com Or call: (877) 888-6759

CIRCLE NO. 111 ON FREE INFORMATION CARD.

**RAZOR SAW**  
It cuts FASTER! EASIER! MORE ACCURATELY!

Order now, only \$25.95 post paid!  
Craftsmen around the world have discovered the secret of better quality work. The Razor Saw cuts by pulling and will give a cleaner, more accurate cut in half the time.

Purchase a RAZOR SAW now and we will include our 102 page catalog of the world's finest woodworking tools. Or send \$2.00 for a two year subscription to our Catalog.

**THE JAPAN WOODWORKER**

1731 Clement Ave. • Alameda, CA 94501 • 1-800-537-7820

CIRCLE NO. 122 ON FREE INFORMATION CARD.

**E**ach year as we sit down to write the “Best New Tools” article, we suffer bouts of indecision. There are always a couple of obvious winners, but filling out the list takes a lot of contemplation. Once complete, it’s interesting to look back at the items we’ve selected and see what the year has brought us.

This year we’ve seen power tools continue to get more versatile and user-friendly – some that are good values as well as good tools and others that are simply premium woodworking tools. The DeWalt planer is more than we ever expected from a portable unit, and the Festool jig-saw is a fine example of German engineering at its height.

We also saw innovations in a couple of areas that often get little attention: Less-expensive but still very useful one-handed clamps from Penn State Industries; sandpaper from Norton that actually lasts as long as you think it should; a clever and amazingly versatile jig from Leigh Industries; and sharpening stones from Shapton that really get things scary sharp.

But the really impressive part of the list this year is the number of extremely well-made hand tools. The power-free area of woodworking continues to grow, and it’s great to see Veritas and Lie-Nielsen meet the demand for

hand tools with offerings that perform even better than vintage tools. Though some of the tools might seem pricey, once you hold them in your hand, you understand their true worth.

We hope our sorting through the slew of this year’s tool crop (pity us) will make your tool shopping a little easier.

by David Thiel & Christopher Schwarz

Questions or comments? You can contact David at 513-531-2690 ext. 1255 or at [david.thiel@fwpubs.com](mailto:david.thiel@fwpubs.com). You can contact Christopher at 513-531-2690 ext. 1407 or at [chris.schwarz@fwpubs.com](mailto:chris.schwarz@fwpubs.com).

# BEST NEW TOOLS OF 2003



## THE WINNERS

DeWalt  
Veritas  
Leigh  
Norton  
Penn State Ind.  
Festool  
Lie-Nielsen  
Shapton  
Grizzly



## DeWalt DW735 13" Planer



With the DW735 planer, DeWalt has done a nice job of making a user-friendly, ergonomically intelligent, high-quality machine.

The features include three double-sided disposable knives that are easily changed and can be adjusted laterally to avoid nicks; a two-speed feed rate (96 or 179 cuts per inch) for a better finish on the final pass; and a four-post chain-driven cutterhead height-adjustment system that is under spring tension to give you snipe-free planing (yes, really!) without a head lock.

The planer also has a fan-assisted chip-ejection

system to make the dust collection even more efficient, a single oversized table, a material removal scale and a single on-board tool for all adjustments.

Right out of the box I was able to produce snipe-free work when taking  $\frac{1}{8}$ " cuts in both maple and pine. The cutterhead's height adjustment is smooth and all of the scales were easy to read and understand. Changing blades (or adjusting to avoid a nick) is easy with ample access to the cutterhead.

While this planer is pricey at \$479, we'd say the thought and engineering that went into it more than compensates for the cost. — DT

Contact DeWalt at 800-433-9258 or [dewalt.com](http://dewalt.com)

## Veritas Medium Shoulder Plane

Shoulder planes are the secret to perfectly fitting mortise-and-tenon joints. But many woodworkers complain that traditional shoulder planes are difficult (or at least awkward) to hold.

The most noteworthy innovation Veritas has on its first shoulder plane is that it is comfortable to hold and use. The rear of the plane and the finger hole are designed to fit your hand and allow you to grasp the tool firmly during each stroke. It's especially comfortable when trimming tenon cheeks and the bottoms of dados.

Another nice touch is the set screws on the sides, which guide the plane's cutter and keep it perfectly positioned in the plane's body.

We're told that wider and narrower versions of this tool are likely on the way, which is good news. This medium shoulder plane is just shy of  $\frac{3}{4}$ " wide, which is good for a lot of work. But we commonly use tenons that are 1" long, so a  $1\frac{1}{8}$ "-wide plane is ideal for trimming tenon cheeks.

One more thing: This plane is an excellent value. At \$139, it is \$85 cheaper than its closest competition, with more features. Look for this plane to be in every woodworker's tool box. — CS



Contact Lee Valley Tools at 800-871-8158 or [leevalley.com](http://leevalley.com)

## Leigh Frame Mortise and Tenon Jig



If you're considering purchasing the Leigh Frame Mortise and Tenon Jig, the No. 1 question has to be: Is this worth \$800? If you cut a lot of mortises and tenons, the answer is a resounding yes. After hours and hours of use and many projects, we're sold. Everything about the jig is slick and intelligent. It turned out accurate joints with more consistency than any other time-tested shop method we know.

The jig's precision is impressive. You can cut tight mortises and tenons in stock up to 3" x  $5\frac{1}{2}$ ", or as small as a matchstick. Both the mortise-and-tenon cuts are guided by a single snap-in guide. Tapered guide pins in a sub-base for

your router follow the guide and offer .001" accuracy. The sub-base itself allows the router to be removed for other uses, then reinstalled to the same accurate setup in a couple of minutes. The initial setup on the base takes a little bit of time and care, but once you have it set, you don't need to worry about it again.

Other important features include an easily adjustable clamping plate with a 30° range for angled joints, a retractable sighting system to quickly locate mortise-and-tenon locations in the material, and table-limiting stops for easy single-joint setup or for repeatable multiple-joint use. — CS

Contact Leigh Industries at 800-663-8932 or [leighjigs.com](http://leighjigs.com)



## Norton 3X Sandpaper

Norton's 3X Sandpaper is so-named because Norton says it sands three times faster and lasts three times longer than other sandpapers. We can't say if it's three times better, but the 3X paper definitely is a gigantic improvement.

The fiber-reinforced backing feels more like cloth than paper. It is resistant to cracking and tearing, which makes the paper last longer and allows you to form it to get into mouldings. Of course, longer paper life isn't important without longer cutting ability. The P-graded abrasive grain (avail-

able in nine grits from #60 to #400) retains its edge a lot longer than conventional abrasives, and the stearate coating keeps the paper from clogging, improving the use-time per sheet. Costing about \$15 for 20 sheets, it's competitively priced. We've switched to 3X in the *Popular Woodworking* shop.

We've also heard from the folks at Norton that 5" hook-and-loop discs for random-orbit sanders (using the same 3X technology) are just around the corner, so we'll be watching for that. —DT

Contact Norton Abrasives at 800-551-4415 or [nortonabrasives.com](http://nortonabrasives.com)

## Penn State Industries Clamp-n-Spread Clamps

Every woodworker knows you can never have enough clamps, but being able to afford them all can be a challenge.

These clamps help with that. They're a popular one-handed design, and the price makes us very excited.

One-handed clamps aren't for panel glue-ups or case construction, but when you need to clamp a jig to your bench or temporarily hold some pieces in place, a one-handed clamp is a joy. Simply squeeze the handle and the lower jaw moves rapidly toward the

other jaw for a speedy grip on your work. These clamps also function as spreaders by relocating the fixed head. Pressing a simple button releases the clamping jaw.

So what do you give up if you buy these clamps? Very little it seems. We found them a bit harder to release than premium clamps, but it's something you quickly get used to.

With the 12" clamps at \$9.95 and the 24" versions at \$13.95, these are half the price of the competition. Everyone should have at least four on their bench. —DT



Contact Penn State Industries at 800-377-7297 or [pennstateind.com](http://pennstateind.com)

## Veritas Scraping Plane

Scraping planes, such as the vintage Stanley No. 112, are notoriously difficult to adjust. When you get them working, they're fantastic – but it's always a monumental struggle. This new Veritas plane (\$129) is the most versatile and easy-to-use scraping plane we've encountered thanks to one small brass knob. Why no one thought about adding this knob before is beyond us.

The knob is a simple thumbscrew behind the plane's blade that allows you to bend the blade slightly – just like the thumbscrew does on a

No. 80 cabinet scraper. This slight bow gives you control over how the blade is set. It also positions the blade to take a "scooping" cut out of your work. The shaving is thickest in its middle and trails out to nothing at its edges. This allows you to scrape large surfaces without leaving "plane tracks," which is where the edges of the cutter dig into the work.

Scraping a surface is markedly superior to sanding it. The wood is sheared instead of abraded and there is no dust packed into the pores. The wood just looks better in the end.

Normally I don't recommend these full-size scraping planes for beginners. But this Veritas version is so simple to set up and use (and it's quite comfortable, too) that virtually any woodworker can make wispy shavings in short order. —CS



Contact Lee Valley Tools at 800-871-8158 or [leevalley.com](http://leevalley.com)

## Festool PS300EQ Trion Jigsaw



Festool's newest jigsaw design has the best toolless blade-changing system we've seen. The fancy lever-assisted device moves the blade forward to clear the blade guides and completely releases the jaws from the blade. It is simple and effortless.

The 6-amp variable-speed motor provides excellent power for all your cutting needs, and the forked-guide system for the blade – with its adjustable carbide pads and rear-bearing support – gives superior blade support and results in minimal blade deflection.

Other nice features include the detachable

13' high-quality rubber power cord. It's great if you ever need to replace the cord, and it makes storing the tool even easier. The jigsaw's shoe bevels to 45° to the left or right and uses an on-board wrench to adjust. The Trion is one of the lightest and fastest-cutting orbital jigsaws on the market, making user fatigue less of a concern.

Available in either the barrel-grip model shown or in a top-handle design (PSB300EQ), the jigsaws cost \$250. It's just about the most expensive jigsaw available, but it really is German (and Festool) craftsmanship at its best. — DT

Contact Festool at 888-337-8600 or [festool-usa.com](http://festool-usa.com)

## Lie-Nielsen Boggs Spokeshave

Once you learn how to tune up a spokeshave, the world of curves is opened wide for you. The problem is that most modern spokeshaves are so poorly made they're more useful for tenderizing a steak than woodworking. Lie-Nielsen Toolworks has changed that with the design assistance of chair-maker Brian Boggs. This new spokeshave puts most modern shaves to shame.

The tool is heavy (12 ounces of bronze, steel and hickory) but it's comfortable and balanced during use. The 1/8"-thick A2 cutter is bedded in the body better than any spokeshave we've ever seen. Combine that with the massive bronze cap that holds the cutter in place and it's no wonder that

you get wispy shavings after a quick honing of the cutter.

Every shop needs at least one spokeshave. They can fair a band-sawn curve faster than any oscillating spindle sander. They can shape curved and rounded surfaces (think about cabriole legs) with more precision than any other tool I know. And they are indispensable for making chairs. While some people might balk at the \$125 price tag (most spokeshaves cost between \$25 and \$85) the truth of the matter is that this tool is worth all that and more. — CS



Contact Lie-Nielsen at 800-327-2520 or [lie-nielsen.com](http://lie-nielsen.com)

## Shapton Sharpening Stones

When choosing a sharpening system, most woodworkers are bewildered by the wide range of options available. So know this: The best all-around sharpening system we've ever tried is the Shapton "professional series" line. Compared to waterstones, Shaptons cut as fast (or faster), wear much more slowly and don't have to be soaked before use – just squirt some water and go.

I guess it's fair to say I like them the most because I have to mess with them the least. Sharpening is extraordinarily quick, so I'm not leaning over them forever as I try to get a good edge. And because they wear

more slowly, flattening them is quick and painless.

Shaptons have been sold in Japan for 20 years but have exploded in the American market this year with the introduction of the professional line, which contains 10 different stones.

For the woodworker, you really need three stones: the #1,000, the #5,000 and the #8,000 grit. The Shapton cast-iron lapping plate also is nice for flattening the stones, but you can get great results with an extra-coarse diamond stone, too. The Shapton system is pricey (\$49 for #1,000, \$76 for #5,000 and \$95 for #8,000), but I believe it's a bargain compared to traditional waterstones, which quickly dish and wear out. — CS

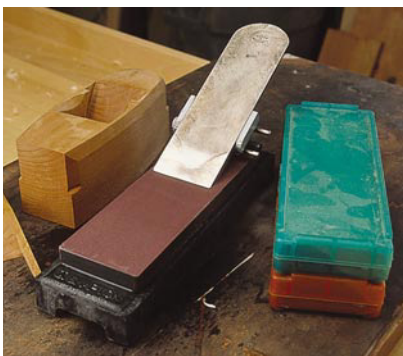

Contact Shapton USA at 877-MYBENCH (692-3624) or [shaptonstones.com](http://shaptonstones.com)

## Grizzly G0500 8" Jointer

When it comes to 8" jointers, nobody can touch Grizzly Industrial. For years, the company's G1018 machine has been the hands-down best value with the unbeatable price of just \$695.

This year Grizzly outdid itself with the new G0500 8" jointer. This machine is much like its little brother, but it has a four-knife cutterhead (instead of three), the bed is 10" longer and the motor is beefier (2 horsepower instead of 1½ hp).

And somehow Grizzly manages to sell this machine for just \$795 (plus shipping).

So what do you give up if you buy one of these machines instead of its closest competitors (which cost \$300 more)? Nothing, as far as we can tell. The

machine we tested was sharp. The fit and finish were superb. The tables and fence were ground perfectly flat. The machine went together with ease and exceeded our every expectation.

If you're in the market for an 8" jointer, this is your baby.

If you're shopping for a 6" machine, you owe it to yourself to save your pennies and step up to the big iron in the G0500. —CS



Contact Grizzly at 800-523-4777 or [grizzly.com](http://grizzly.com)

## And Another Thing...

*There were a number of tools that were either too new to include or are going through some refinements that affect their inclusion. While not full-fledged Best New Tools of 2003, they deserve mention and watching:*

### ■ Porter-Cable's 890 Router Series:

Porter-Cable is re-energizing a part of the router market that it established – the multi-base kit. With the new 890 routers, Porter-Cable has set the bar high with variable speed, a soft-start 2¼-hp motor and three base options. The two bases shown below are the fixed and plunge bases. The fine-adjustment depth features are impressive and a two-position power switch makes hand-held or router-table use equally convenient. Bit changes and height adjustments also are possible through a router table's top with these units. The third base is the Grip Vac handle, a vari-



ation on a "D" handle base that offers through-the-handle dust collection. These routers and kits cost \$190-\$250. (Contact: 800-321-9443 or [porter-cable.com](http://porter-cable.com))

■ **Lie-Nielsen Chisels:** Hand-tool users have been waiting for these for a long time. We can't say much except that we think the long wait will be worth it. (Contact: 800-327-2520 or [lie-nielsen.com](http://lie-nielsen.com))

■ **New Rip Dozuki Saws:** Dovetailing is best done with a rip saw, but until recently finding a rip dozuki has been a challenge. Lee Valley Tools now sells one (\$69), as does [toolsforworkingwood.com](http://toolsforworkingwood.com) (\$80). Both saws are excellent after preliminary tests. (Contact: 800-871-8158 or [leevalley.com](http://leevalley.com))

■ **JET Multitool:** We tried like heck to get our hands on this one. It is a grinder that runs a very slick sandpaper sharpening system using a high-tech 3M sandpaper. Plus it includes a disc sander. Very cool. (Contact: 800-274-6848 or [jettools.com](http://jettools.com))

■ **Shepherd Tools' A6 Smoothing Plane:** Look for this beautiful dovetailed smoothing plane with brass sides, steel sole, high-pitch (47½°) iron and Norris-style adjuster. The kit will be \$465. This small Canadian company has been releasing a slew of new products recently. (Contact: 519-624-7350 or [shepherdtool.com](http://shepherdtool.com))

■ **Glü-Bot & Bábe-Bot:** These glue bottles from FastCap deliver the correct amount

of glue exactly where you want it. While the products are good, we understand some planned refinements will improve them. (Contact: 888-443-3748 or [www.fastcap.com](http://www.fastcap.com))

■ **Trend Airshield:** The respected British tool company is entering the U.S. market with a self-contained face shield that ventilates and cools while keeping dust away from the user. See our full review on page 32. (Contact: 859-485-2080 or [trend-usa.com](http://trend-usa.com))

■ **Miller Dowels:** This joint-making system shown above hit the market hard this year, offering quick, strong and hidden joinery. Basically an option to screws, the system offers an all-wood, self-capping joint. Available in a growing variety of wood species, the dowels are a little expensive and may not be the product for every project, but they are worth taking a look to see if it's a reasonable option for your work. (Contact: 866-WOODPEG [966-3734] or [millerdowel.com](http://millerdowel.com)) **PW**



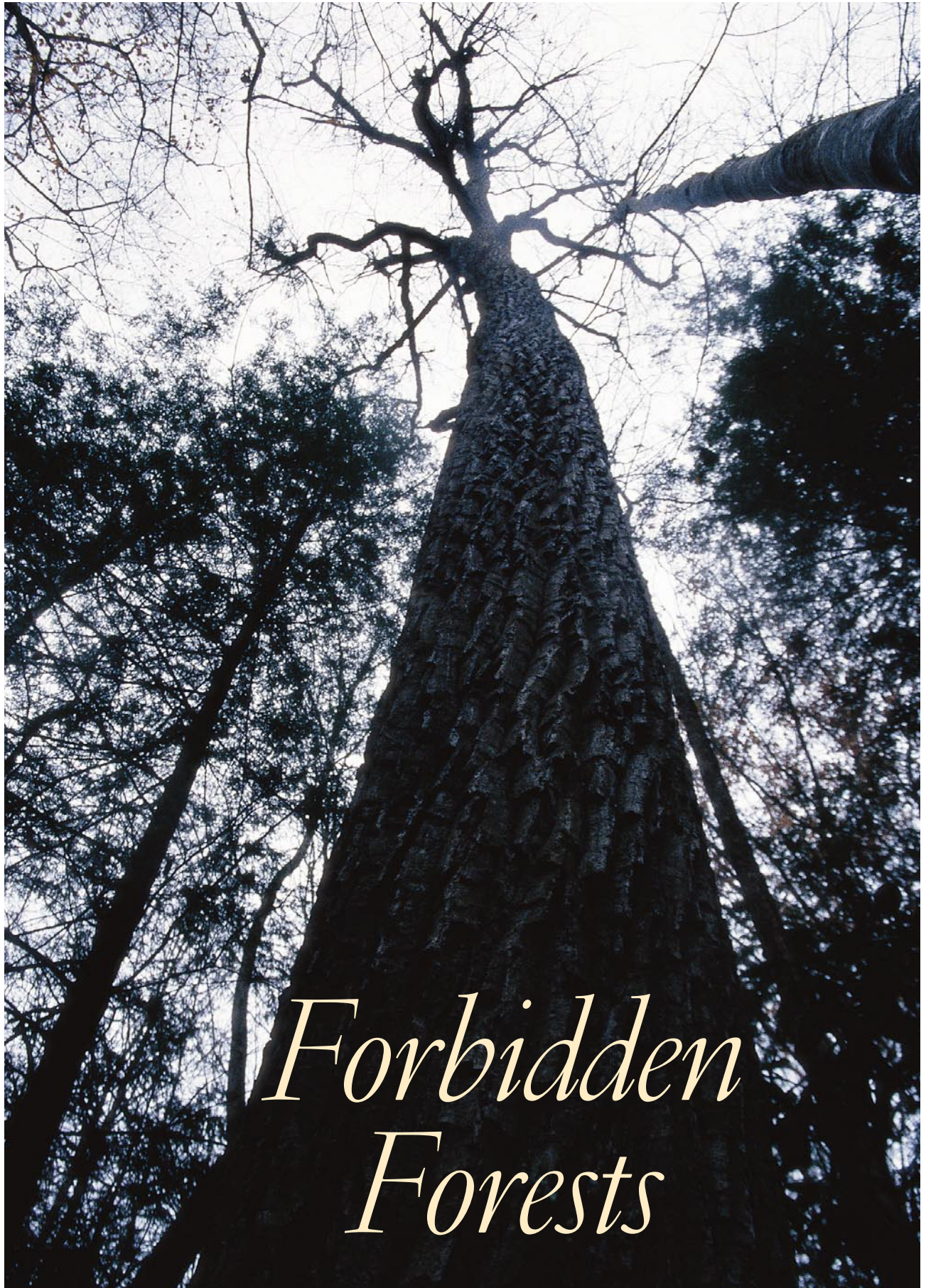

# Many old-growth trees are on protected land that will never be forested. But some ancient wood makes it to market.

## Is it worth working with?

### We find out.

**W**e crashed down a steep hill covered in ancient rhododendron thickets and the effect was complete. This forest was so old and civilization so far away that we could have been settlers forging through the Cumberland Gap. Poplars stood 120' tall and measured 4' in diameter. Their once-young, fine-textured bark was now riven with deep grooves causing us to misidentify them in their winter attire as chestnut oaks. The trees looked wrinkled, magnificent and old. Among the poplars were ancient hemlocks and 300-year-old beech trees, which grew neck-achingly tall on Pine Mountain's mossy, fern-covered south slope.

In another era, these trees would have been cut down and used for everything from furniture and firewood to bowls and fuel. But this particular forest – Blanton Forest in eastern Kentucky – is protected. These trees will never see a table saw. But some old-growth wood (mostly recycled) does. Many people believe old-growth offers richer color, tighter grain and more strength than newer wood. Before you begin searching for some old-growth lumber, here are some important things you should know.

#### What is Old Growth?

There are a slew of definitions for the term “old growth,” in part because different species of trees require different definitions.

But most scientists agree on these key conditions:

- A percentage of old, large-diameter trees must be present.
- The forest must exhibit a dense,

diverse canopy with trees of many different heights, standing snags (dead trees that simply refuse to fall) and a forest floor cluttered with decomposing logs.

- The soil of an old-growth forest is usually carpeted with moss, fungi and ferns, with large root balls pushing the earth apart.
- The forest must remain, for the most part, undisturbed by people. Because wood is, and always has been, integral to human life, “undisturbed by people” is what makes a virgin forest so rare.

#### History of our Trees

In 1630, 46 percent of the United States was forested, according to Jeff Ghannam, communications director at the Society of American Foresters. That number dropped to 30 percent in 1920, but has risen gradually to 33 percent (based on a 1997 figure).

In his book “A Reverence for Wood,” (Ballantine Books) Eric

Sloane describes the early importance of wood: “The century of magnificent awareness preceding the Civil War was the age of wood. ... It spanned rivers for man; it built his home and heated it in the winter; man walked on wood, slept in it, sat on wooden chairs at wooden tables, drank and ate fruits of trees from wooden cups and dishes. From cradle of wood to coffin of wood, the life of man was encircled by it.”

According to Sloane, a painter and chronicler of early American life, in the period following the Civil War, many iron factories began inventing things suitable for peacetime production. He writes: “Anything which hitherto had been made of wood was quickly duplicated and mass-produced in iron. ... The American reverence for wood had become old-fashioned and obsolete almost overnight, and the individual makers of wooden things

became rare artisans. There rose a quest for new ways to use wood, even to the point of wasting it.”

Plans were made for building wooden highways, called plankroads. Log jams in rivers were common occurrences. Steamboats and locomotives used wood for fuel. According to Sloane, the English criticized Americans for wasting trees.

Connecticut, which embraced manufacturing, is today well-known for its many trees. In fact, according to Ghannam, 60 percent of Connecticut is covered in forests (based on 2001 figures). But this wasn't always so. In his book, Sloane describes the view over Connecticut's Berkshires around 1865, looking north from Cornwall. Should you have looked at the countryside from any elevated point, he writes, you could have “counted the big trees on the fingers of your hands.”

Deforestation was as common an occurrence then (perhaps even more so) as it is today. According to Ghannam, national forests were created by the Organic Act of 1897 to combat the deforestation that occurred at the end of the 19th century. In the beginning of the 20th century, the creation of the U.S. Department of Agriculture, Forest Service and the profession of forestry helped deter deforestation by introducing scientific logging and re-planting techniques.

Most of today's forests are filled with second-growth wood – young trees that have revitalized the forests that were once stripped for settlers' needs. Today, we build most of our wooden furniture and homes from second-growth wood.

by Kara Gebhart

*Comments or questions? Contact Kara at 513-531-2690 ext. 1348 or kara.gebhart@fwpubs.com*

#### ABOUT BLANTON FOREST

Pine Mountain is in Blanton Forest, tucked away in the southeastern corner of Harlan County, Ky. It is the 13th largest old-growth forest in the eastern United States. First recognized in 1992 and later purchased by the Kentucky State Nature Preserves Commission through efforts of the Kentucky Natural Lands Trust, the forest was opened to the public in 2001. The 2,350 acres of ancient beech, poplar, hemlock and oak are protected by a 4,350-acre buffer. Special thanks to our guides, Daniel Collett, Blanton Forest steward for the Kentucky Natural Lands Trust, and Kyle Napier, nature preserves regional manager for southeast Kentucky. For more information about Blanton Forest, call 877-367-5658 or visit [blantonforest.org](http://blantonforest.org).



This Boise Payette Truck is hauling logs from somewhere around the Warm Lake area east of Cascade, Idaho. This picture, which was taken between 1933 and 1937, illustrates the size of trees logged in the early 20th century.

### Old vs. New

What can trees become? Obviously, if left in place they can become great in size. Many of us have heard of General Sherman, California's giant sequoia that is 102.6' in circumference. Or Jardine Juniper, Utah's 3,200-year-old rocky mountain juniper. There's also Bennett Juniper, California's 3,000-year-old western juniper, and the late Wye Oak, Maryland's great white oak with a regal crown that spanned 119'. (Wye Oak died in June 2002.)

There are also the tales of 30"-wide by 8'-long tables built from one slab of wood, homes built inside of hollowed trees and local dances that took place on top of fallen ones.

But there's more to old-growth wood than size and age. Some species become more decay-resistant, stronger and darker in color as they age. Redwood is a

prime example, according to Regis B. Miller, a project leader in the Center for Wood Anatomy Research at the U.S. Department of Agriculture, Forest Service, Forest Products Laboratory.

By the time a redwood reaches the ripe old age of 100, it has had a lot of time to create the necessary polyphenols, fats, waxes, oils, resins, gums and tannins – what some scientists call extractives – needed for decay resistance. (Extractives also are a tree's aromatic and coloring materials.) When you look at old-growth redwood, it's very dark in color, Miller says. Darker color means more extractives, which signifies a higher resistance to decay.

According to Miller, Southern yellow pine is another prime example of the differences in old-growth wood versus second-growth wood. Old-growth Southern yellow pine (what many refer to as

heart pine, longleaf pine or hard pine) has distinct, heavy bands of latewood and distinct bands of earlywood. (In Southern yellow pine, the soft, light layers are earlywood and the darker, denser layers are latewood.) Typically these bands of earlywood and latewood are equal in width.

"As a consequence, you have a distinctive grain pattern that people are raving about," Miller says. Some reclaim this pine from reconditioned houses and buildings from the early 1900s and install it in new homes, he adds.

Most of today's Southern yellow pine is grown at a fast clip on managed plantations and is cut down when it's about 20 years old. Therefore, its band of latewood is much narrower than its band of earlywood. Latewood typically has higher density. So second-growth Southern yellow pine is lower in density, lighter in color and, according to Miller, not as strong. Today this wood is most commonly used in construction as a dimensional lumber.

Many people often cite the spacing of annular rings as another common example of a difference between old-growth and

second-growth wood. In many species of old-growth trees, the wood's annular rings are tighter. According to Miller, trees produce tighter annular rings when they grow slowly, which is often the case with old-growth trees. Some argue that when trees grow in an environment that provides a dense, multilayered canopy, the trees are competing for sunlight and therefore grow at a slower pace. Miller says that slow growth typically occurs when a stand is very mature and old.

Of course, all of this varies from species to species. For instance, when comparing old-growth hardwoods to second-growth hardwoods (versus softwoods), the differences in density and strength aren't as noticeable. For example, Miller says, the decay resistance of old-growth white oak, compared to second-growth white oak, is the same as far as we know.

Miller also says that second-growth white oak actually is stronger than old-growth white oak. When the growth of a white oak tree slows, it typically only produces earlywood, he says. This earlywood is lower in density,

## VISIT AN ANCIENT FOREST

GORP.com, an online resource for outdoor recreation, publishes Top 10 lists on everything from scenic drives to favorite parks. Following is a list compiled by Mark Leger listing GORP.com's Top 10 ancient forests in the United States:

### The East

Joyce Kilmer Memorial Forest, N.C.  
Eglin Air Force Base, Fla.  
Congaree Swamp National Monument, S.C.  
Five Ponds Wilderness  
Adirondacks State Park, N.Y.  
Isle Royale National Park, Mich.

### The West

Great Basin National Park, Nev.  
Redwood National Park, Calif.  
Opal Creek, Willamette National Forest, Ore.  
Gila National Forest, N.M.  
Tongass National Forest, Alaska

For more information about each forest, visit [http://gorp.com/gorp/activity/wildlife/topten\\_oldgrowth.htm](http://gorp.com/gorp/activity/wildlife/topten_oldgrowth.htm)



Which one is old growth? In some species (such as Southern yellow pine) old-growth wood is easy to identify because of its distinct, heavy bands of latewood and distinct bands of earlywood. But in many hardwoods (such as the red oak shown here), the rings look the same. The top board is old growth. The bottom board is second growth.

leaving the wood weaker. In faster-growing second-growth white oak, the bands of latewood typically are wider, creating a stronger piece of wood.

### Working with Old Growth

Intrigued by Miller's comments, we decided to compare the old with the new by building two doors. We built one door using salvaged antique red oak, which we obtained by contacting Antique & Vintage Woods of America (518-398-9663 or [floorings.com](http://floorings.com)). We built the second door using second-growth red oak, which we bought from our local lumberyard.

As you can see in the above photo, when looking at the end grain, it's hard to tell which piece of wood is old growth and which is second growth. The old-growth red oak was slightly darker in color and contained a few more knots. But we noted no differences when working with the wood. In fact, we had to mark the wood "old" and "2nd" to keep them straight.

So why work with old growth? In some species, you are going to find tighter annular rings, stronger wood that's richer in color and wood that has a higher resistance to decay. But in other species, the

benefits and joy of working with old growth are more psychological than physical: The properties of the wood may be similar to those of the wood you buy at your local lumberyard; it's the story behind the wood that makes it extra-special.

### Buying Old Wood

Although comparatively rare and considerably more expensive, there are several ecologically sound ways to get your hands on old-growth wood. Of course, logging old-growth lumber from a protected forest is not one of them. If caught cutting down ancient trees in a protected area, you could be slapped with some hefty fines.

You're also not going to see old-growth wood marketed at your local home-center store or your local lumberyard. No company is going to market its lumber as "old growth" because of the stigma attached to the term, according to Michael Klein, spokesman for the American Forest & Paper Association.

But it's not just marketing that keeps old-growth wood out of the lumberyards. According to Klein, there really isn't much old-growth wood to market. Most of the old-growth wood that is owned has

been entered into land-swap agreements with the government or environmental groups, he says. But this doesn't mean old-growth trees aren't harvested.

According to Klein, most forestland is privately owned. If approached by the government or a conservation organization, a landowner typically will agree to allow the government or other organization to manage a small portion of the land but will then harvest the rest. When dealing with things such as urban sprawl, agreements such as this ensure a win-win situation, Klein says.

Although it's highly doubtful anyone's going to run a highway through an old-growth forest anytime soon, highways are built, urban areas do sprawl and nature does take its course, meaning old-growth trees still are harvested.

So if old-growth trees are present in your region, chances are you'll find a few boards while digging through the stacks at your local lumberyard. But there's not going to be a sign advertising it as such. The spacing of the growth rings will be your only clue.

Your best bet to find old-growth wood is to buy reclaimed wood. Reclaimed lumber includes fallen trees on personal property, and logs discovered in lakes or rescued from barns or old buildings. The price of old-growth wood recovered from bodies of water and older buildings built more than a century ago is about two to three times the cost of regular hardwood. For information on where to purchase old-growth wood, check out "Buying Antique, Vintage and Reclaimed Wood" at right. For more information about the recovery process from the Great Lakes, check out Gregory Crofton's article titled "Buying Submerged Lumber" online at [popwood.com](http://popwood.com) by clicking on "Magazine Extras."

## BUYING ANTIQUE, VINTAGE & RECLAIMED WOOD

Check out the following companies for antique or vintage wood rescued from old buildings, old barns or people's private property, or reclaimed from lakes. Note that some of these companies sell wood only in large quantities (250 board feet or more):

**Antique & Vintage Woods of America**  
518-398-9663 or [floorings.com](http://floorings.com)

**Barn Shadow Enterprises**  
877-380-8446 or [barnshadow.com](http://barnshadow.com)

**Black's Farmwood**  
415-499-8300 or [blacksfarmwood.com](http://blacksfarmwood.com)

**Colonial Lumber**  
301-334-3189 or [coloniallumber.com](http://coloniallumber.com)

**Heartwood Associates, Int'l.**  
573-747-1733 or [heartwoodassociates.com](http://heartwoodassociates.com)

**Old Growth Woods**  
651-690-3188 or [oldgrowthwoods.com](http://oldgrowthwoods.com)

**Timeless Timber**  
888-653-5647 or [timelesstimber.com](http://timelesstimber.com)

**Vintage Timberworks**  
909-695-1003 or [vintagetimber.com](http://vintagetimber.com)

If you do get your hands on some old-growth wood, take a moment and think about its history. Perhaps it served as a rafter in an old barn for more than a 100 years, sank while being transported via a waterway or was logged to make room for human settlement. Regardless, the wood was around long before you were born, and with a little work and a little luck, you can turn it into something that will exist long after you're gone. **PW**



# Traditional Wooden Planes

Hardly obsolete, these tools are capable of your finest work.

My heart sank as my master pointed to a 22"-long wooden try plane he suggested I use until I filled out my personal kit of tools. I was training as an apprentice at The Ohio Village, a "living history" site where visitors experience life in a typical 1860s Ohio town. Though I was intrigued by the wooden stock planes, the metal Bailey/Stanley-style planes were in regular use in the shop, and I felt I was going to be at a disadvantage using the more primitive wooden ones.

Deciding to make the best of it, and with

my master's guidance, I ground and sharpened the iron (checking its fit to the bed, the cap iron and the wedge), and I jointed the sole. The mouth opening was pretty tight, so we decided to use it for a while before making a decision on re-mouthing it.

by Don McConnell

*Don McConnell builds furniture and does ornamental carving in Mount Vernon, Ohio. He remains an avid student of the history of the trade, tools and shop practices.*

After some instruction on how to adjust and set the iron, as well as learning where to put my hands for face- and edge-planing, I took my first shavings with it.

To my relief and surprise it worked quite well. Further, I found that I liked the feel of the wood-on-wood action, the unique sound and the authority with which it took shavings the full length of the board. As a bonus, I found wooden planes less tiring to use during long planing sessions. I was hooked.

Clearly, my assessment of wooden planes

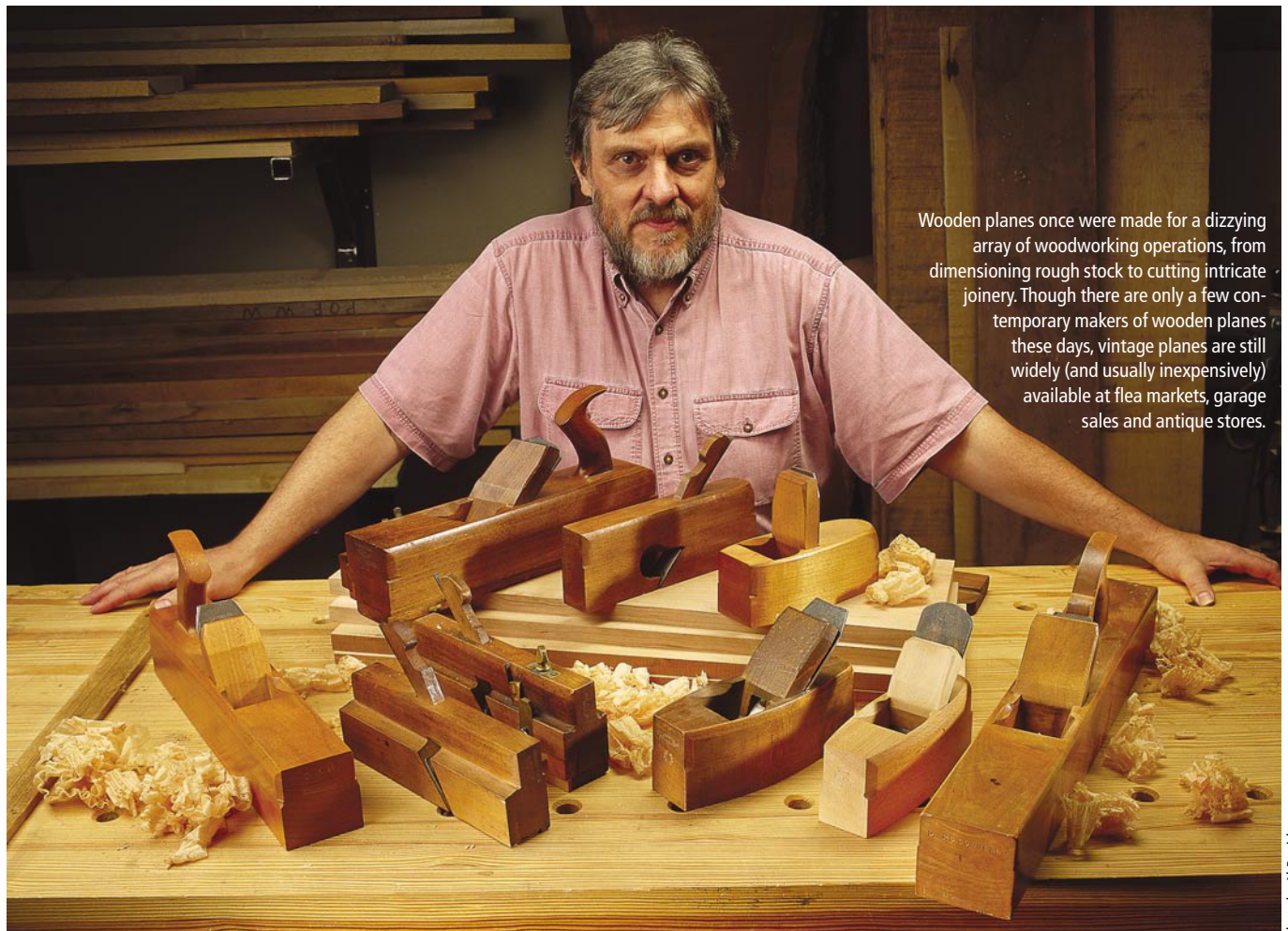

Wooden planes once were made for a dizzying array of woodworking operations, from dimensioning rough stock to cutting intricate joinery. Though there are only a few contemporary makers of wooden planes these days, vintage planes are still widely (and usually inexpensively) available at flea markets, garage sales and antique stores.

Photo by Al Parrish

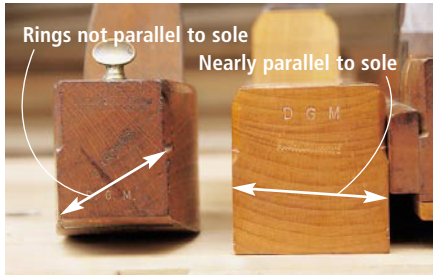

Traditional wooden planes are made from quarter-sawn beech with the plain-sawn side acting as the sole, as seen at right. However, some exceptions do occasionally surface. In the compass plane at left, the plain-sawn side is not parallel to the sole.

had been off the mark. And the more I studied and used them (including making some for myself), the more convinced I became that their apparent simplicity belied a well-developed and sophisticated design, one that embodied the woodworking lore of generations of woodworkers, including specialized plane-makers from about 1650 on.

Historic evidence for the range and quality of work these planes can perform is found in the extraordinarily fine furniture made during the 18th century – furniture that is commonly accepted to be the zenith of American furniture-making.

Wooden planes were involved in the surfacing, thickening and dimensioning of nearly every element of that furniture. Indeed, the achievements of the cabinetmakers of that period were made possible, in part, by similar levels of craftsmanship the plane-makers of that century exhibited.

In this article I hope to give you a broader appreciation of these tools and to provide some clues regarding the desirable features and characteristics to look for in older planes.

**The Wood of Choice**

Except for some early New England plane-makers who used yellow birch for a time, plane-makers have customarily chosen beech. While beech is not a “perfect” wood for making planes, it combines a number of characteristics that make it the best overall choice for use in plane-making.

It is reasonably hard and dense, giving it decent strength and wear resistance. Yet it is relatively easy to shape compared to sugar maple, for example, rendering it more workable for day-to-day work by plane-makers. It is small-pored, not prone to splintering

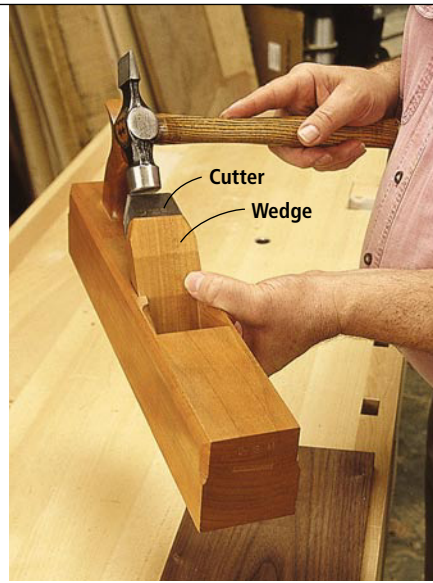

Adjusting a wooden plane’s cutter isn’t mysterious. To advance the cutter for a deeper cut, lightly tap on it. Then tap the wedge to lock in your adjustment.

and has a relatively smooth, polished surface. Despite an unfortunate tendency to check while drying, it is not particularly “rivable,” thus it resists complete failure. Also, beech is readily available in an appropriate form and size for plane-making, so it is relatively economical.

Other woods – such as apple, boxwood and rosewood – have some features suitable for making planes and sometimes were chosen for use in special planes. But none of these woods had the combination of characteristics and availability to unseat beech as the customary wood of choice.

In addition to choosing beech, the best plane-makers exhibited their skill in the way they made use of it. For example, they selected straight-grained material that was relatively defect-free. This helped minimize any tendency of the tool to bow or distort through environmental changes.

Additionally, they almost invariably used quarter-sawn beech – orienting it so the annual rings were roughly parallel with the sole of the plane. One outcome of this is that the plane’s body (commonly referred to as the stock) is much less likely to “cast,” or go out of square, through seasonal changes.

Another result of the use of quarter-sawn stock in this orientation was that the vertical dimensional movement was minimized. This brought about much less distortion of the plane’s bed over time.

This orientation also resulted in a “plain-sawn,” or tangential, surface serving as the sole of the plane. I believe this was done be-



To make a lighter cut, tap the heel of the plane with your mallet and then tap the wedge. Some planes have a “strike button” on the topside of the tool’s stock in front of the blade. You also can tap the strike button to reduce the cut.

cause plain-sawn surfaces are more resistant to wear. In my experience planing beech I have noticed that the plain-sawn surfaces are noticeably more recalcitrant – though I don’t have technical data to back this up. Also, plane-makers used the “sap-side” surface as the sole. Some writers claimed this surface was more wear-resistant than the “heart-side” surface, but I haven’t seen any formal documentation of this.

Finally, if there was any noticeable grain run-out in the plane blank, plane-makers customarily oriented the toe and heel of the plane so that any downward inclination of the grain was toward the heel. Thus, any abrasion of the sole would tend to smooth the grain rather than lift and roughen it.

**Adjusting the Cutter**

There are several other aspects of traditional wooden planes that exhibit the same sense of refinement as the stock. But I thought it might be more useful to turn our attention to the perception that setting and adjusting the irons seems primitive and imprecise. This, in turn, gives rise to a common suspicion that wooden planes aren’t for fine work.

While the means of adjustment seem mysterious, once understood they are both simple and capable of increasing the control and precision. Adjusting the plane can be a bit of an acquired skill, but in experienced hands, a wooden plane is capable of very fine work.

With wooden planes, it’s important that

the wedge, which secures the iron in the stock, fits well. If properly fit, this wedge will hold the iron with a surprisingly light tap of a mallet or hammer. (It's really best to watch someone with experience to get a clear idea of the amount of force involved.) This avoids distorting the plane stock, minimizes the chance of splitting the abutment cheeks and allows for more controlled adjustment.

Adjusting the iron is achieved through the simple physics of inertia. If you need to advance the set of the iron to take a deeper cut, tap the upper end of the iron with a hammer. It then moves down relative to the stock.

If you wish to back off the set of the iron, you have a couple of choices. You can tap either the heel of the plane or the upper surface at the front of the plane (probably best if there is a "strike button," as shown in the illustration below) with a mallet.

Loosening the iron for sharpening is accomplished with somewhat sharper mallet raps in the same locations. Lateral adjust-

ment is a simple matter of tapping the iron sideways as necessary. In each case, because the iron and wedge are both tapered along their lengths, you need to reset the wedge with another light tap before checking the set and putting the plane to use.

### Perfectly Simple

Perhaps it's fitting that these traditional wooden planes exhibit a certain elegance of design we normally think of as a modern industrial-design sensibility – a sensibility that stresses a straightforward and functional use of appropriate materials.

It's an elegance summed up by Antoine de Saint-Exupery (who was not only an aviator and author, but also an aircraft designer in the early 20th century): "A designer knows he has achieved perfection not when there is nothing left to add, but when there is nothing left to take away."

There are some long-term issues that arise because the stocks of these planes are wood,

such as wear and dimensional changes caused by changes in environment. Also, because of the taper of the irons and the configuration of the throat of the escapement, the mouth opens as the iron gets shorter as it's sharpened and the sole is jointed.

While wearing of the sole is something of a reality, its significance is often exaggerated. Soles need to be jointed more often because of frequent changes in environment – not because of wear.

In any event, after the sole has been jointed many times, the mouth will open enough to degrade the performance of the plane. But that can be remedied with a patch using simple woodworking skills.

One of the best reasons to consider using wooden planes is the wide variety of specialized planes available that can be useful for virtually any woodworking operation you can imagine. While they are not as easy to find as they once were, they continue to reappear and can be very affordable. **PW**

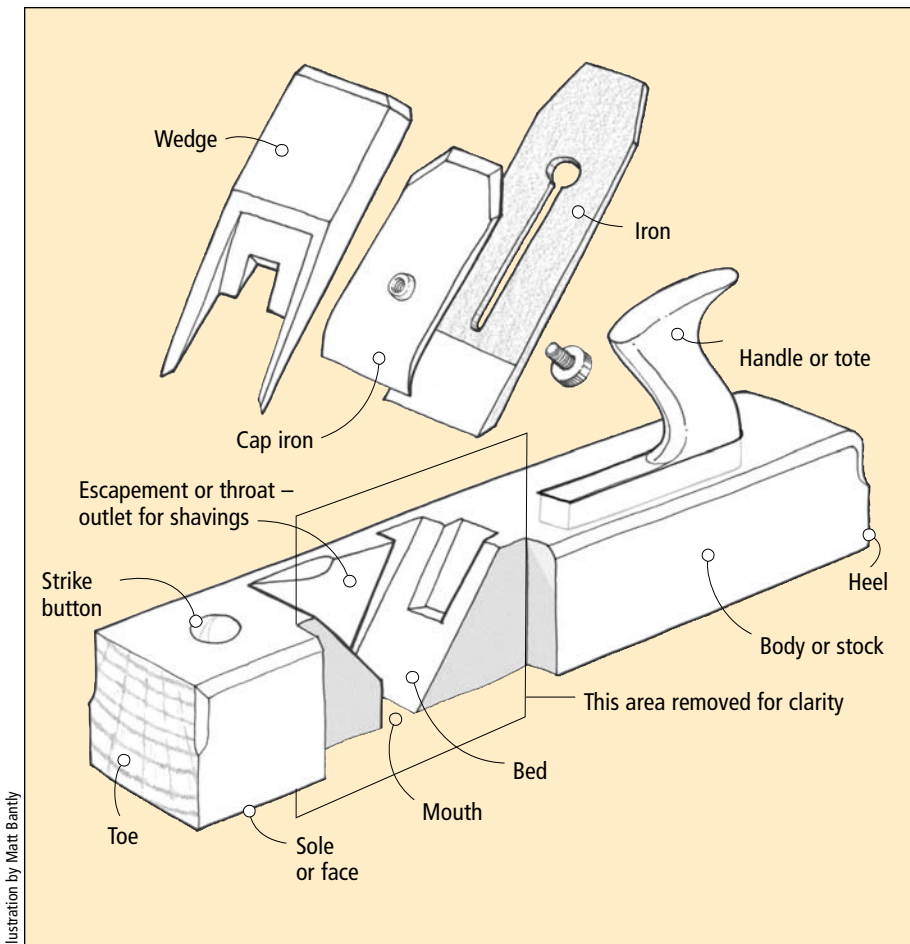

A properly tuned wooden plane is a joy to use. Nearly every surface of traditional 18th-century furniture was shaped or smoothed with a wooden plane.

## Glen-Drake Toolworks

Feel the Difference !



left and right-handed hammers for  
left and right-handed people

1-800-961-1569 • [glen-drake.com](http://glen-drake.com)

CIRCLE NO. 119 ON FREE INFORMATION CARD.

Lie-Nielsen  
TOOLWORKS  
INC.

Heirloom Quality Tools  
1-800-327-2520

[www.lie-nielsen.com](http://www.lie-nielsen.com)



Low Angle Adjustable Mouth Block Plane \$150

CIRCLE NO. 132 ON FREE INFORMATION CARD.

## Special Issues from Popular Woodworking!

Looking for some project inspiration? Want to find the perfect power tool to fit your needs and budget? Need the perfect backyard furniture? Want to turn that awkward space in your home into a storage area? Then look no further than the Special Issues from the editors of *Popular Woodworking*! Inside each, you'll find all the information you need: materials selection and cutting lists, step-by-step plans, exploded drawings, and clear direction.

Storage & Shelving  
Outdoor Furniture  
Great American Furniture  
Woodshop Essentials  
Tool Buying Guides  
Historic Projects  
And more!

Visit [www.PopularWoodworking.com](http://www.PopularWoodworking.com) for a full selection of *Popular Woodworking* Special Issues, and more!

## one good TURN -after another



Our TC90-100 Lathe: for a lifetime of carefree turning

SUGGESTED RETAIL  
**\$299.99**

Standard #2 Morse tapers and 1x 8 TPI



Accepts bed extension; allowing 39" between centers

Heaviest in it's class - 86 lbs.

Powerful, heavy-duty 1/2 HP motor

Easy access to change speeds



For more details and a list of dealers visit our website • [fisch-woodworking.com](http://fisch-woodworking.com)  
**Fisch Precision Tools Inc.**  
Claysville, PA • Ph: 724-663-9072

CIRCLE NO. 114 ON FREE INFORMATION CARD.

## Fine Tune Your Band Saw for Great Cutting Performance!

Cool Blocks are made from a non-metallic composite called "Graphite Impregnated Phenolic Laminate". These high-tech Band Saw Blade Guides lubricate the blade without making it oily. Old metal guide blocks create heat, friction, premature blade wear and breakage.

**Eliminate these problems with Cool Blocks.**

Your Band Saw Blades will run cooler and last longer with less friction!

Visit your Olson Dealer and ask for Cool Blocks Band Saw Blade Guides!

Top Rated by *Fine Woodworking Magazine*, Mar/Apr. 2001

Dealer inquiries are welcome!  
Call 203-792-8622

**OLSON**  
The Olson Saw Co.  
16 Stony Hill Road,  
Bethel, CT 06801 USA  
[www.olsonssaw.com](http://www.olsonssaw.com)



CIRCLE NO. 137 ON FREE INFORMATION CARD.

# Build it yourself

with help from Popular Woodworking Books!



## BUILD YOUR OWN KITCHEN CABINETS 2<sup>ND</sup> EDITION

by Danny Proulx

Superbly detailed, this fully updated guide walks you through all the stages of planning, design, construction and installation of kitchen cabinets.

#70626-K \$24.99 pb



## BUILDING WOODSHOP WORKSTATIONS

by Danny Proulx

Whether you're fighting cramped quarters or looking to be more organized, you'll want these 11 detailed plans for building completely self-contained units for every tool and accessory in your shop.

#70585-K \$24.99 pb

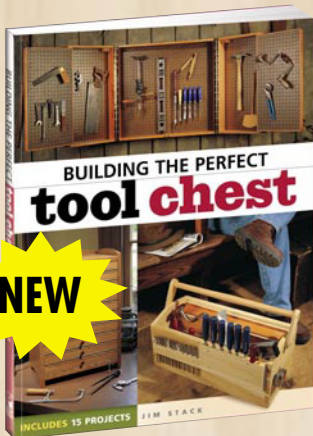

## BUILDING THE PERFECT TOOL CHEST

by Jim Stack

Get clear and easy-to-follow instructions for building 15 tool chests. Each practical and stylish design is adaptable to individual needs and provides a convenient place to store all of a woodworker's tools.

#70598-K \$24.99 pb

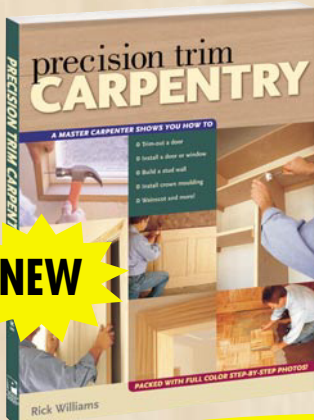

## PRECISION TRIM CARPENTRY

by Rick Williams

Save money and gain satisfaction as you learn to craft your own precision trim carpentry. Projects include trimming a door, installing windows and wainscot panels, hanging drywall, patching Sheetrock and more!

#70584-K \$24.99 pb

### ORDER FORM

Please enter number of copies next to desired selection(s):

- \_\_\_ *Build Your Own Kitchen Cabinets, 2<sup>nd</sup> Edition* (#70626-K) \$24.99  
 \_\_\_ *Building Woodshop Workstations* (#70585-K) \$24.99  
 \_\_\_ *Building the Perfect Tool Chest* (#70598-K) \$24.99  
 \_\_\_ *Precision Trim Carpentry* (#70584-K) \$24.99

SUBTOTAL: \$ \_\_\_\_\_

In the U.S., please add \$3.95 shipping and handling for the first book, \$1.95 for each additional book. In OH, NY, CO, MA and MI add applicable state tax. In Canada, add US\$5.00 for the first book, US\$3.00 for each additional book, and 7% GST. Payment in U.S. funds must accompany order.

TOTAL: \$ \_\_\_\_\_

- Check or money order enclosed - or -  
 Charge my  VISA  MasterCard  AmEx Exp. \_\_\_\_\_

Acct.# \_\_\_\_\_

Signature \_\_\_\_\_

Name \_\_\_\_\_

Address \_\_\_\_\_

City \_\_\_\_\_

State/Prov. \_\_\_\_\_ ZIP/PC \_\_\_\_\_

ZAM03PW

Send to:  Popular Woodworking Books  
 PO Box 9274  
 Central Islip, NY 11722-9274

These selections are available at your favorite bookseller, or direct from the publisher using the Order Form to the right.

For more information or to order by Credit Card visit  
[www.popularwoodworking.com/store](http://www.popularwoodworking.com/store)  
 or call toll free 1-800-448-0915

MEDIA SPONSOR

**Popular  
Woodworking®**

EDUCATION SPONSOR

**AMERICAN SYCAMORE  
WOODWORKERS' RETREAT**

SAWDUST CAFÉ SPONSOR

**WoodCentral**

FINISHING SPONSOR

**ZINSSER**  
QUALITY SINCE 1849



**WATCH FOR SIGNS.**

WoodWorks™ is on the road again.

**WoodWorks**

...woodworking at its best

L E A R N | S H O P | B E I N S P I R E D

SHOW INFORMATION: **WOODWORKSEVENTS.COM** 310.917.4408

**SPRINGFIELD  
MASSACHUSETTS**

JAN. 16 - 18, 2004

**ONTARIO  
CALIFORNIA**

JAN. 30 - FEB. 1, 2004

**PHOENIX  
ARIZONA**

FEB. 6 - FEB. 8, 2004

# PRODUCT INDEX

	PAGE #	CIRCLE #	WEB ADDRESS
<b>ADHESIVES</b>			
Franklin International	26	116	titebond.com
Gorilla Glue	65	120	gorillaglu.com
<b>BITS, BLADES &amp; CUTTERS</b>			
Amana	12	102	amanatool.com
Forrest Mfg.	35	115	stores.yahoo.com/forrestman
Freud	Insert	117	freudtools.com
Freud	Insert	175	freudtools.com
Hickory	48	136	oldham-usa.com
Librawood	102	131	librawood.com
Olson	101	137	olsonaw.com
Ridge Carbide	108	144	ridgecarbide.com
Routerbits.com	108	147	routerbits.com
Woodline USA	6	159	woodbits.com
<b>BOOKS</b>			
Woodworker's Book Club	80-81	—	woodworkersbookclub.com
<b>FASTENERS</b>			
DowelMax	106	138	dowelmax.com
Kreg Tool	86	127	kregtool.com
McFeely's	20	134	mcfeelys.com
Miller Dowel Co.	105	135	millerdowel.com
<b>FINISHES &amp; SUPPLIES</b>			
Waterlox	108	153	waterlox.com
<b>FURNITURE &amp; PROJECT PARTS</b>			
Adams Wood Products	24	100	adamswoodproducts.com
Osborne Wood Products	105	140	osbornewood.com
<b>HAND TOOLS</b>			
BrandNew Industries	108	108	adjustableclamp.com
E. Emerson Tool Co.	86	111	allinoneclamps.com
Fine Tool Journal	108	113	finetoolj.com
Glen-Drake Tool Works	101	119	glen-drake.com
Japan Woodworker	86	122	thejapanwoodworker.com
Lie-Nielsen Toolworks	101	132	lie-nielsen.com
Tools For Working Wood	108	150	toolsforworkingwood.com
Wilton	9	125	wiltoncorp.com
<b>HARDWARE</b>			
Whitechapel Ltd.	24	154	whitechapel-ltd.com
Woodworker's Hardware	18	162	wwhardware.com
<b>KITS &amp; PLANS</b>			
Shortridge Co.	108	149	shorridgelt.com
U-bild.com	108	151	u-bild.com
Woodcraft Plans	108	158	woodcraftplans.com
<b>MISCELLANEOUS</b>			
Dakota Alert	108	110	dakotaalert.com
<b>POWER TOOL ACCESSORIES</b>			
Beall Tool	108	105	bealltool.com
Bench Dog Tools	88	106	benchdog.com
Biesemeyer	14	107	biesemeyer.com
Craftsman Gallery	108	109	thecraftsmangallery.com
Jointech	20	126	jointech.com
Leigh	18, 33	—	leighjigs.com
<b>POWER TOOLS</b>			
Ashman Technical	18	104	woodworktools.com
Delta Machinery	15	164	deltamachinery.com
Delta Machinery	16	165	deltamachinery.com
Delta Machinery	17	166	deltamachinery.com
Delta Machinery	19	167	deltamachinery.com
Fein Power Tools	25	112	feinusa.com
Fisch	101	114	fisch-woodworking.com
General Mfg.	33	118	general.ca
Grizzly Industrial	C2-1	121	grizzly.com
Grizzly Industrial	23	168	grizzly.com
JET Tools	2	156	jettools.com
JET Tools	5	123	jettools.com
JET Tools	7	124	jettools.com
Laguna Tools	C4	128	lagunatools.com

	PAGE #	CIRCLE #	WEB ADDRESS
<b>POWER TOOLS</b>			
Legacy Woodworking	108	130	legacywoodworking.com
Makita	21	133	makitatools.com
RB Industries	24	143	rbiwoodtools.com
RB Industries	106	169	rbiwoodtools.com
Ridgid	13	145	ridgid.com
Sears Craftsman	C3	148	craftsman.com
Wilke	65	155	wilkemach.com
Woodstock Int'l	27	160	woodstockinternational.com
<b>SHOP ACCESSORIES</b>			
Airware America	108	101	airwareamerica.com
Oneida Air Systems	65	139	oneida-air.com
Woodpeckers	109	142	woodpeck.com
<b>TURNING SUPPLIES</b>			
Packard Woodworks	108	141	packardwoodworks.com
<b>WOOD &amp; VENEERS</b>			
Newton Woods	108	—	walnutwoods.net
Wall Lumber	12	152	walllumber.com
West Penn Hardwoods	65	—	westpennhardwoods.com
Woodfinder	108	—	woodfinder.com
<b>WOODWORKING CATALOGS</b>			
Amazon	88	103	amazon.com
Lee Valley Tools	18	129	leevalley.com
Rockler	33	146	rockler.com
Woodcraft	10-11	157	woodcraft.com
Woodworker's Choice	108	161	thewoodworkerschoice.com
Woodworker's Supply	24	163	woodworker.com
<b>WOODWORKING SHOWS</b>			
Woodworks 2003	103, 107	—	woodworks2003.com

## See something you want? Need more information?

Use the Free Information Card in this issue to receive free advertiser information.

For **faster service**, go **online** at [www.popwood.com](http://www.popwood.com) and click "FREE INFORMATION" or **fax the card** to (585) 321-0043.

## Win A DeWalt DW618PK Router System



When you request information, you're automatically entered in our drawing to win a DeWalt DW618PK Router System. When we tested this router, it performed well, felt good in our hands

## BUILD YOUR BEST WITH THE NEW MILLER DOWEL



Miller® Dowels are currently offered in multiple sizes and are intended for use with a corresponding TruFit Drill Bit. Available in Birch, Cherry, Red Oak and Black Walnut.

### SUPERIOR FASTENERS FOR SOLID WOOD JOINERY

- **SIMPLE** – fast and easy to use
- **STRONG** – solid, longer-lasting joints
- **ECONOMICAL** – minimal tools required
- **VERSATILE** – use in any woodworking project
- **UNIQUE** – the only natural fastener designed for insertion from the outside
- **EXCELLENT RESULTS** – an appealing and durable alternative to metal fasteners



1 DRILL STEPPED PILOT HOLE



2 ADD GLUE & INSERT



3 TAP & FINISH

1-866-WOODPEG



www.millerdowel.com

U.S. Patent No. 6,267,527 U.S. Patent No. D456,700 TM 2003 Miller is a trademark of the Miller Dowel Company.

CIRCLE NO. 135 ON FREE INFORMATION CARD.

## MEET OUR NEWEST KITCHEN ISLAND TRIO!



**OSBORNE**   
Wood Products, Inc.  
www.osbornewood.com

8116 Highway 123 North  
Toccoa, GA 30577  
Request a catalog: 1-800-746-3233  
Order line: 1-800-849-8876

CIRCLE NO. 140 ON FREE INFORMATION CARD.

# ADVERTISER INDEX

ADVERTISER	PAGE #	CIRCLE #	WEB ADDRESS
Adams Wood Products	24	100	adamswoodproducts.com
Airware America	108	101	airwareamerica.com
Amana	12	102	amanatool.com
Amazon	88	103	amazon.com
Ashman Technical	18	104	woodworktools.com
Beall Tool	108	105	bealltool.com
Bench Dog Tools	88	106	benchdog.com
Biesemeyer	14	107	biesemeyer.com
BrandNew	108	108	brandnew.net
Craftsman Gallery	108	109	thecraftsmangallery.com
Dakota Alert	108	110	dakotaalert.com
Delta Machinery	15	164	deltamachinery.com
Delta Machinery	16	165	deltamachinery.com
Delta Machinery	17	166	deltamachinery.com
Delta Machinery	19	167	deltamachinery.com
DowelMax	106	138	dowelmax.com
E. Emerson Tool Co.	86	111	allinoneclamps.com
Fein Power Tools	25	112	feinusa.com
Fine Tool Journal	108	113	finetoolj.com
Fisch	101	114	fisch-woodworking.com
Forrest Mfg.	35	115	stores.yahoo.com/forrestman
Franklin International	26	116	titebond.com
Freud	Insert	117, 175	freudtools.com
General Mfg.	33	118	general.ca
Glen-Drake Tool Works	101	119	glen-drake.com
Gorilla Glue	65	120	gorillaglu.com
Grizzly Industrial	C2-1	121	grizzly.com
Grizzly Industrial	23	168	grizzly.com
Hickory	48	136	oldham-usa.com
Japan Woodworker	86	122	thejapanwoodworker.com
JET Tools	2	156	jettools.com
JET Tools	5	123	jettools.com
JET Tools	7	124	jettools.com
Jointech	20	126	jointech.com
Kreg Tool	86	127	kregtool.com
Laguna Tools	C4	128	lagunatools.com
Lee Valley Tools	18	129	leevalley.com
Legacy Woodworking	108	130	legacywoodworking.com
Leigh	18, 33	—	leighjigs.com
Librawood	108	131	librawood.com
Lie-Nielsen Toolworks	101	132	lie-nielsen.com
Makita	21	133	makitatools.com
McFeely's	20	134	mcfelys.com
Miller Dowel Co.	105	135	millerdowel.com
Newton Woods	108	—	walnutwood.net
Olson Saw Co.	101	137	olsonaw.com
Oneida Air Systems	65	139	oneida-air.com
Osborne Wood Products	105	140	osbornewood.com
Packard Woodworks	108	141	packardwoodworks.com
RB Industries	24	143	rbiwoodtools.com
RB Industries	106	169	rbiwoodtools.com
Ridge Carbide	108	144	ridgecarbide.com
Ridgid	13	145	ridgid.com
Rockler	33	146	rockler.com
Routerbits.com	108	147	routerbits.com
Sears Craftsman	C3	148	craftsman.com
Shortridge Co.	108	149	shortridgelt.com
Tools for Working Wood	108	150	toolsforworkingwood.com
U-bild.com	108	151	u-bild.com
Wall Lumber	12	152	walllumber.com
Waterlox	108	153	waterlox.com
West Penn Hardwoods	65	—	westpennhardwoods.com
Whitechapel Ltd.	24	154	whitechapel-ltd.com
Wilke Machinery	65	155	wilkemach.com
Wilton	9	125	wiltoncorp.com
Woodcraft	10-11	157	woodcraft.com
Woodcraft Plans	108	158	woodcraftplans.com
Woodfinder	108	—	woodfinder.com
Woodline USA	6	159	woodbits.com
Woodpeckers	109	142	woodpeck.com
Woodstock Int'l.	27	160	woodstockinternational.com
Woodworker's Book Club	88-89	—	woodworkersbookclub.com
Woodworker's Choice	108	161	thewoodworkerschoice.com
Woodworker's Hardware	18	162	wwhardware.com
Woodworker's Supply	24	163	woodworker.com
Woodworks 2003	103, 107	—	woodworks2003.com



# ROUTERSHOP

HAWK Woodworking Tools.

"The router tool with a brain"

- No fancy bits required - with a simple bit you can create a complete set of cabinets
- Patented tilting table - set your cutter vertically & horizontally for a safe, new way to make cuts
- No time consuming set-ups, the calibrated crossfeed system does it automatically with its built-in "brain"
- Solid steel work surface - no flimsy chipboard to warp
- Factory Direct Savings

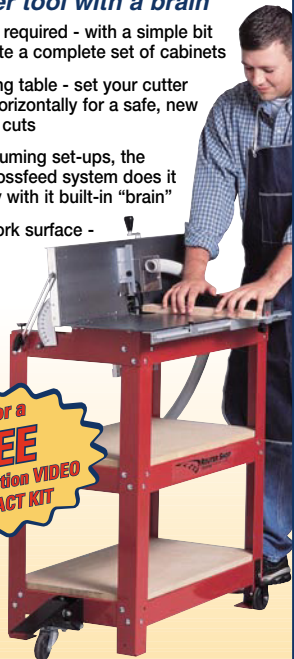

Ask for a **FREE** Demonstration VIDEO and FACT KIT

R03011

Discover how the Hawk RouterShop™ can help you unlock your woodworking potential.

Call 1-800-487-2623

www.hawkwoodworkingtools.com

© 2003 rbindustries, inc.

CIRCLE NO. 169 ON FREE INFORMATION CARD.

# DOWELMAX

PRECISION ENGINEERED JOINING SYSTEM



Create strong, professional joints.

Create offset, mitre, "T", face, panel joints, virtually any configuration from 1"x1" to 1"x12" and 2"x2" to 4"x4"

Perfect substitute for a mortise and tenon. Package includes six accessories, drill bit, drill stop and video.

Example shown: 1"x6" to a 4"x4" offset joint for coffee table. 12 hardwood dowels to create a strong, precise corner assembly.

www.dowelmax.com

Toll Free 1.877.986.9400

Tel. 604.986.1850 • Fax 604.986.9406

CIRCLE NO. 138 ON FREE INFORMATION CARD.

## Popular Woodworking Customer Service

"Reader satisfaction is our #1 concern. If you ever have any questions, please let us know right away. We'll take care of it."

— Steve Shanesy  
Editor & Publisher

### How do I contact customer service?

Visit popularwoodworking.com and click on the "Subscriber Services" button on the left-side navigation bar, write to *Popular Woodworking*, P.O. Box 5369, Harlan, IA 51593, or call 800-888-6880 or 515-280-1721.

### When does my subscription expire?

The date that appears on your magazine mailing label above your name is the date of the last issue in your subscription.

### Will I be put on other mailing lists?

We make our subscriber names available on a limited basis to other reputable companies whose products and services may be of interest to you. If you prefer not to receive these mailings, simply send your magazine label with instructions not to release your name to: List Manager, F&W Publications, 4700 E. Galbraith Road, Cincinnati, OH 45236.

### Why did I receive a bill after I've paid?

If you have already mailed your payment, please disregard any bill or renewal notice. Our letters probably got crossed in the mail. (However if you continue to receive bills or renewal notices, please let us know.)

### Will you replace damaged or missing issues?

We'll replace the damaged or missing issue, or extend your subscription, whichever you prefer.

### 100% Satisfaction Guarantee

If at any time you're less than satisfied with *Popular Woodworking*, let us know and we'll refund your entire subscription amount. No questions asked.

## Popular Woodworking

popwood.com  
4700 E. Galbraith Road  
Cincinnati, Ohio 45236  
Editorial Office:  
popwood@fwpubs.com

Get a **FREE** sneak peek at the latest

- woodworking tools
- woodworking news
- bargain tool prices
- workshop tips
- upcoming PW issues

Log on to popularwoodworking.com and sign up for *Popular Woodworking E-News*. This **FREE** email newsletter briefs you on the latest tips, tricks and tool tidbits we've gathered through the woodworking grapevine. *E-News* will come straight to your email box every couple weeks, so you'll get all the up-to-the-moment information you need.

Sign up today!

www.popularwoodworking.com

STATEMENT OF OWNERSHIP, MANAGEMENT AND CIRCULATION (required by Act of August 12, 1970: Section 3685, Title 39, United States Code). POPULAR WOODWORKING is published seven times a year at 4700 E. Galbraith Road, Cincinnati, Ohio 45236. The general business offices of the publisher and the editor are: Publisher and Editor, Stephen Shanesy, 4700 E. Galbraith Road, Cincinnati, Ohio 45236. The owner is F&W Publications, Inc.: Stephen J. Kent, President and CEO. Address: 4700 E. Galbraith Road, Cincinnati, Ohio 45236. The extent and nature of circulation is: A. Total number of copies printed (Net press run). Average number of copies each issue during preceding 12 months 240,151. Actual number of copies of single issue published nearest to filing date 247,000. B. Paid circulation. 1. Sales through dealers and carriers, street vendors and counter sales. Average number of copies each issue during the preceding 12 months 58,230. Actual number of copies of single issue published nearest to filing date 73,360. 2. Mail subscriptions. Average number of copies each issue during preceding 12 months 124,069. Actual number of copies of single issue published nearest to filing date 118,553. C. Total paid circulation. Average number of copies each issue during preceding 12 months 182,299. Actual number of copies of single issue published nearest to filing date 191,913. D. Free distribution by mail, carrier or other means. Samples, complementaries and other free copies. Average number of copies each issue during preceding 12 months 833. Actual number of copies of single issue published nearest to filing date 934. E. Total distribution (Sum of C and D). Average number of copies each issue during preceding 12 months 183,132. Actual number of copies of single issue published nearest to filing date 192,847. F. 1. Office use, leftover, unaccounted, spoiled after printing. Average number of copies each issue during preceding 12 months 6,514. Actual number of copies of single issue published nearest to filing date 1,051. 2. Returns from news agents. Average number of copies each issue during preceding 12 months 50,505. Actual number of copies of single issue published nearest to filing date 53,102. G. Total (Sum of E and F should equal net press run shown in A). Average number of copies of each issue during preceding 12 months 240,151. Actual number of copies of single issue published nearest to filing date 247,000. I certify that the statements made by me above are correct and complete. Filed October 1, 2003. Stephen Shanesy, Publisher.

MEDIA SPONSOR

**Popular  
Woodworking**<sup>®</sup>

EDUCATION SPONSOR

**AMERICAN SYCAMORE  
WOODWORKERS' RETREAT**

SAWDUST CAFÉ SPONSOR

**WoodCentral**

FINISHING SPONSOR

**ZINSSER**  
QUALITY SINCE 1849



# WATCH FOR SIGNS.

WoodWorks™ is on the road again.

# WoodWorks

...woodworking at its best

WoodWorks is revved-up for a new season of nationwide events designed to please woodworkers of all skill levels. Shop for the newest **tools and supplies** you won't find in retail stores, **watch and learn** from experts who come from around the world or **be inspired** as you wander through exhibition galleries of fine work. WoodWorks is family-friendly with many free demonstrations and activities for all ages.

**Work safely & see you on the Road!**

L E A R N | S H O P | B E I N S P I R E D

VISIT OUR WEBSITE: **WOODWORKSEVENTS.COM** 310.917.4408

**SPRINGFIELD  
MASSACHUSETTS**

JAN. 16 - 18, 2004

**ONTARIO  
CALIFORNIA**

JAN. 30 - FEB. 1, 2004

**PHOENIX  
ARIZONA**

FEB. 6 - FEB. 8, 2004

# WOODWORKER'S MARKETPLACE

## TWC

### The Woodworker's Choice

SAVE \$ - check the TWC web site for numerous **BIG BARGAIN** overstock & close-out items such as: saw blades, router bits, shaper cutters, clamps, etc. You'll also find more **BIG \$ SAVINGS** on the **WEEKLY SPECIAL ITEMS** we select from regular TWC catalogs.

[www.thewoodworkerschoice.com](http://www.thewoodworkerschoice.com)  
**CALL TOLL FREE: 1-800-892-4866**

CIRCLE NO. 161 ON FREE INFORMATION CARD.

## U-BILD.COM

On-line catalog pictures hundreds of full-size woodworking plans at low prices. Free downloadable mini-plans. All skill levels. Free shipping. 48-page color catalog \$2.00 (refunded on 1st order) call (800) 828-2453.

CIRCLE NO. 151 ON FREE INFORMATION CARD.

**Need a precise and affordable tool for routing furniture joints?**



Visit us...  
**we are the WoodRat® specialists!**

[www.chipsfly.com](http://www.chipsfly.com)

CIRCLE NO. 109 ON FREE INFORMATION CARD.

Get a **Free Copy** of our **CATALOG** for **WOODTURNERS**



Call Toll Free... **1-800-683-8876**  
 or write... **1-800-683-8876**  
**Packard Woodworks PO Box 718 Tryon, NC 28782**  
 website: [www.packardwoodworks.com](http://www.packardwoodworks.com)

CIRCLE NO. 141 ON FREE INFORMATION CARD.

## Routerbits.com

**Bits, Blades, Books & more...**

Whiteside Router Bits Fisch Forstner Bits  
 Systematic Saw Blades Bench Dog  
 Books & Accessories

Call Toll Free **1-888-811-7269**  
[www.routerbits.com](http://www.routerbits.com)

CIRCLE NO. 147 ON FREE INFORMATION CARD.

## Build a Child's Rocker

learn the intricacies of Craftsman construction



**Craftsman Rocker Kit**

- precision-cut white oak or cherry
- leather upholstered seat in black, navy, pine, or red
- complete instructions with photos

KIT • \$105 + S&H \$15.95  
 All major credit cards accepted.

**SHORTRIDGE COMPANY LTD**  
 Furniture Craftsmen  
[www.ShortridgeLtd.com](http://www.ShortridgeLtd.com)  
 TOLL FREE 1-888-335-3393

20.5" H x 10.5" W x 19" D  
 SEAT HEIGHT 10"

CIRCLE NO. 149 ON FREE INFORMATION CARD.

## Hand Tools for Serious Woodworkers

Reproduction **Norris A5 Infill smoother** by Ray Iles. **\$649.95**



complete catalog online  
[www.toolsforworkingwood.com](http://www.toolsforworkingwood.com)  
 27 W 20 St. #507, New York City  
**Call 800-426-4613**

CIRCLE NO. 150 ON FREE INFORMATION CARD.

## NEWTON WOODS



Featuring Superior

- Black Walnut Burl, Maple Burl, Madrone Burl and Red Gum Burl/Veneers
- Burl Slabs
- Gun Stock Blanks
- Turning Wood

Phone: **559-277-8456**  
 E-mail: [calfbman@aol.com](mailto:calfbman@aol.com)  
 Web: [WalnutWoods.net](http://WalnutWoods.net)

Tung Oil Based Wood Finishes Since 1916  
 Waterlox Tung Oil penetrates • No sanding necessary for adhesion • Great for use with Exotics • Protects against moisture, heat/cold, household chemicals • Very easy to apply, maintain & re-coat • Hand-crafted for 4 generations • For more information, visit us at [www.waterlox.com](http://www.waterlox.com), e-mail: [info@waterlox.com](mailto:info@waterlox.com) or call: **1.800.321.0377**



CIRCLE NO. 153 ON FREE INFORMATION CARD.

## "Forrest" Saw Blades

10" Woodworker II - \$97  
 10" Chopmaster - \$109  
 12" Chopmaster - \$123  
 8" Dado King - \$227

[www.librawood.com](http://www.librawood.com)

CIRCLE NO. 131 ON FREE INFORMATION CARD.

## BRANDING IRONS

as low as **\$54.95**

**BRANDNEW**  
**1-800-964-8251**  
**www.brandnew.net**

CIRCLE NO. 108 ON FREE INFORMATION CARD.

## Looking for wood?

**VISIT woodfinder**



**It's fast, easy and FREE!**  
[www.woodfinder.com](http://www.woodfinder.com)  
 No computer? Call toll-free 1-877-933-4637

## CUSTOM ROUTER BITS, CUTTERS & KNIVES

2 week or less delivery

### LIBERTY LINE

WHEN IT COMES TO ROUTER BITS WE KNOW WHAT WE'RE TALKING ABOUT.

**RIDGE CARBIDE TOOL CO.**  
 "Industry Leader In Custom Router Bits"

FAX us your custom drawings toll free at 1-888-RCT-TOOL (728-8665) or mail drawings or wood samples

**RIDGE CARBIDE TOOL CO.**  
 595 New York Ave., PO Box 497, Lyndhurst, NJ 07071  
 Call for complete 100 page Stock Tool Catalog or see us at [www.ridgecarbide.com](http://www.ridgecarbide.com)  
**800-443-0992 rcttool@bellatlantic.net**

CIRCLE NO. 144 ON FREE INFORMATION CARD.

## The Wood Buff 3-ON LATHE MANDREL



New accessory allows you to do all three wood buffing steps without changing wheels! Great for pens & other small items.

For information call or write: Dept. PW  
**THE BEALL TOOL CO.**  
 541 Swans Road., N.E. Newark Ohio 43055  
 Toll Free 1-800-331-4718  
 Website: [www.bealltool.com](http://www.bealltool.com)

CIRCLE NO. 105 ON FREE INFORMATION CARD.

## WIRELESS DRIVEWAY ALARMS



Lets you know anytime anyone walks or drives into your place.

**DAKOTA ALERT, INC.**  
BOX 130, ELK POINT, SD 57025  
605-356-2772  
[www.dakotaalert.com](http://www.dakotaalert.com)

CIRCLE NO. 110 ON FREE INFORMATION CARD.

## FREE PLANS CATALOG!

[www.WoodcraftPlans.com](http://www.WoodcraftPlans.com)

"THE place to find hundreds of plans."

Call for a catalog: 800.296.6256

CIRCLE NO. 158 ON FREE INFORMATION CARD.

[www.AirwareAmerica.com](http://www.AirwareAmerica.com)

3M Safety Products, including Power Visor, Airstream, Airmate and BreatheEasy respirators. Trend Airshield, Peltor AM/FM Worktunes & Wing Little Giant Aluminum Ladders.  
[www.AirwareAmerica.com](http://www.AirwareAmerica.com)  
800-328-1792

CIRCLE NO. 101 ON FREE INFORMATION CARD.

Lie-Nielsen Standard or Low Angle Block Plane. Special \$135.00.

Fine Tool Journal  
27 Fickett Rd.,  
Pownal, ME 04069  
(800) 248-8114



Always Free  
US Shipping on  
Lie-Nielsen Tools!

Full line  
on web.

[www.FineToolJ.com/LN](http://www.FineToolJ.com/LN)

CIRCLE NO. 113 ON FREE INFORMATION CARD.

## NEW Steel Clamp Racks

SALE only  
**\$19.95**  
2+/\$18.50 ea.

Save Space!

Holds 200 lbs in 22".  
Bar or Pipe style available.



Order on-line [www.woodpeck.com](http://www.woodpeck.com)

CIRCLE NO. 142 ON FREE INFORMATION CARD.

[www.legacywoodworking.com](http://www.legacywoodworking.com)



Turn  
without  
a lathe!

call 800-279-4570

to request a  
FREE demo CD

CIRCLE NO. 130 ON FREE INFORMATION CARD.

## FREE PROJECT PLANS

[www.popularwoodworking.com](http://www.popularwoodworking.com)

## CLASSIFIED

Classified rate is \$4.75 per word, 15-word minimum. Order must be accompanied by payment; ads are non-commissionable. Send to: Popular Woodworking, Barbara Gasper, 4700 E. Galbraith Rd., Cincinnati, OH 45236, Phone: 610-967-1330, Fax: 513-531-1843.

### BOOKS

WE HAVE A WIDE VARIETY of woodworking books – from small projects, to home improvement, to enhancing your woodworking skills, and more! To see our full line of books, please visit our Website at [www.popularwoodworking.com/store/books!](http://www.popularwoodworking.com/store/books!)

### BUSINESS OPPORTUNITIES

EASY WORK! EXCELLENT PAY! Assemble Products At Home. Call Toll Free 1-800-467-5566 Ext.3445.

### FINISHING SUPPLIES/EQUIPMENT

SPRAY-ON SUEDE. Line boxes easily. Free brochure with sample. DonJer, 13142 Murphy Road, Winnebago, IL 61088; 800-336-6537; [www.donjer.com](http://www.donjer.com)

### HARDWARE

WWW.PROFHDWR.COM Almost 3000 woodworking & related products available with our New shopping cart. Professional Hardware.

### KITS & PLANS

WWW.CHERRYTREE-ONLINE.COM Clocks, toys, whirligigs, intarsia, feeders & more. Call 800-848-4363 XPOW013.

CARLYLE LYNCH MEASURED DRAWINGS Museum and private collection furniture plans by Carlyle Lynch. Catalog \$2. PO Box 13007, Arlington, TX 76094; 817-861-1619.

### MISCELLANEOUS

POST OFFICE BOX DOOR FRONTS, #1 \$9.00 + S&H. Coin slot plates, etc. to make banks. SASE for info. Hubbert, PO Box 1415, Fletcher, NC 28732; 828-687-0350.

### "NEW IDEA? IMPROVE A PRODUCT?"

Free Invention Assessment. Patenting, industry presentation, licensing. Free information. 1-800-501-2252; [www.franklinforge.com](http://www.franklinforge.com)

### SOFTWARE

DESIGN INTUITION: CAD redefined! Create professional blueprints MAC.OS X. [www.gizmolab.com/save/pw](http://www.gizmolab.com/save/pw)

## Special Issues from Popular Woodworking!

Looking for some project inspiration? Want to find the perfect power tool to fit your needs and budget? Need the perfect backyard furniture? Want to turn that awkward space in your home into a storage area? Then look no further than the Special Issues from the editors of *Popular Woodworking!* Inside each, you'll find all the information you need: materials selection and cutting lists, step-by-step plans, exploded drawings, and clear direction.

**Great American Furniture**  
**Storage & Shelving**   **Outdoor Furniture**  
**Woodshop Essentials**   **Tool Buying Guides**  
**Historic Projects**   **And more!**

Visit [www.PopularWoodworking.com](http://www.PopularWoodworking.com) for a full selection of *Popular Woodworking* Special Issues, and more!

# 9 Myths of Finishing

Some are marketing ploys, others are just plain bewildering.

I doubt any craft is more burdened with myths than wood finishing. We all suffer from misinformation about the finishing products we use: what they are, what they do and how to use them.

On the other hand, the existence of so many myths demands that they regularly be debunked. So here are nine of the most common and pervasive untruths about finishing.

## Myth 1: Tung oil is one of the best finishes you can use.

Real tung oil is difficult to use and is far less protective and durable than the finish that's actually in most of the cans labeled "tung oil."

It all started on TV infomercials in the early 1970s when Homer Formby promoted tung oil as a great finish and then put varnish thinned with paint thinner in the containers he sold. People had success with his product because varnish, even thinned varnish, really is a great finish.

But the promotion launched one of the most pervasive deceptions in the finishing industry – that cans labeled tung oil really contain tung oil. Many manufacturers have now joined Formby and market their own thinned varnish, which they label or promote as "tung oil." (FYI: Real tung oil never contains petroleum distillate, takes two to three days to dry after wiping off the excess and doesn't get hard.)

## Myth 2: Oil and oil/varnish blends such as Watco are good finishes because they protect the wood from the inside.

Hey, when you're trying to sell a finish that dries too soft to be built up for good protection, you've got to come up with something. So why not claim that what can't be done on the surface can be done where it



Photos by Al Parrish

**Myth 7:** Bubbles in your finish aren't caused by shaking the can. They're the result of turbulence created as you move your brush. You can easily fix the problem by brushing back over the finish.

can't be seen – inside the wood? Now that's some pretty clever marketing.

But it's not true. While oils do penetrate the wood deeper than some fast-drying, film-building finishes, all oils and oil/varnish mixtures are notorious for water-spotting – rapidly developing areas of dullness caused by water penetrating and raising the grain. If

you use one of these finishes, you'd be wise to wet the wood and sand off the raised grain before applying the finish. That way the water-spotting will be much less noticeable.

## Myth 3: The only finishes safe for cutting boards, salad bowls and baby objects are oils with no metallic driers.

If this were true, how would you account for products called "Salad-bowl Finishes" that are marketed and promoted as food-safe? These finishes are oils that must contain metallic driers or they would take weeks to

by Bob Flexner

*Bob Flexner is the author of "Understanding Wood Finishing" and a contributing editor to Popular Woodworking.*

cure. (And if you've used a salad-bowl finish, you know it dries much more rapidly.)

In fact, salad-bowl finishes do contain metallic driers, but it isn't a problem. The FDA approves the use of metallic driers in coatings that will come in contact with food. They do require, though, that the finish be allowed to fully cure before use, and this is what you should be looking for. All finishes – and I mean all finishes – are safe for contact with food or babies once the finish has fully cured.

I mean, you'd hear about it on the news if they weren't safe! Why this myth persists, I simply don't understand.

#### **Myth 4: Pigment stain obscures or muddies the wood's grain.**

Come on! I know you've used a stain that contains pigment because almost all stains sold in paint stores and home centers do. So you know they don't obscure wood when the excess is wiped off; they actually intensify the wood's characteristics.

Sure, if you leave any stain on too thick it will obscure the wood, but no one is advocating doing something like this.

#### **Myth 5: You need to use a sealer under a finish to promote finish adhesion.**

If this was true, why are you specifically told to not use a sealer under polyurethane? Why do you rarely find a sealer for water-based finish and never for shellac? Does it make any sense that varnish and lacquer require sealers for bonding and other finishes don't?

Here's the explanation: The first coat of any finish bonds perfectly well, whether it's applied full-strength or thinned. Special products are used for the first coat when there's a problem to be dealt with. Sanding sealers are used under varnish and lacquer to make sanding the first coat easier. Shellac is used as the first coat when there's a problem in the wood that needs "sealing off" – such as pine resin, silicone or odor from animal urine or smoke.

#### **Myth 6: Shellac is the best sealer.**

This is the case only if there's a problem (as explained above), and you rarely have a problem with newly built projects. Wouldn't the high-end furniture industry use a shellac sealer if it really performed better? Furniture



**Myth 4:** A pigment stain (applied to the right side of the board) doesn't obscure the grain, it highlights it.

manufacturers spend huge amounts of money on their finishes, and they don't use shellac. Why would they skimp on sealing or bonding if shellac really did these better?

#### **Myth 7: You can prevent air bubbles by not shaking or stirring a finish.**

Try it (if you haven't already). Take a can of varnish, polyurethane or water-based finish. Remove the lid very carefully so as not to disturb the finish. Insert your brush and spread the finish onto a surface. Voilá! Bubbles.

It's not shaking or stirring that causes bubbles, it's the turbulence created by moving the brush over the surface. You can't avoid bubbles during application. Your goal should be to keep them from drying in the finish.

Do this by lightly brushing back over the finish (called "tipping off") to break the bubbles, or thin the finish a little so the bubbles have more time to pop out on their own before the finish skins over.

#### **Myth 8: Silicone in furniture polish damages the finish.**

For half a century, the most popular furniture polishes have contained silicone because this substance (actually a synthetic oil) provides better scratch resistance and makes furniture look better. Is it possible that the majority of consumers were destroying their furniture all this time without anyone ever noticing? Not likely.

In fact, silicone is totally inert and it doesn't damage anything.

What silicone does do when it gets into the wood is cause craters or "fish eyes" in new finishes applied during refinishing, and

this problem requires extra time to prevent. So refinishers and conservators hate silicone, and they are the ones responsible for spreading this myth.

#### **Myth 9: Oil-based varnishes last only a couple of years in the can because the metallic driers deactivate.**

Not all myths are old. This one began less than two years ago in another woodworking magazine and has already been repeated. It's probably the most amazing myth of all because almost everyone has a can or two of varnish (or oil paint, for that matter) that is more than two years old and it cures just fine. How far removed from real-world finishing does a person have to be to come up with this myth?

I don't know that varnish ever goes bad – except, of course, when it skins over and cures in the can because of exposure to oxygen. **PW**



Photo by the author

**Myth 8:** Silicone in furniture polish does not damage your finish. The only problem silicone can cause are craters or "fish eyes" when the wood is refinished. This will take more effort to overcome.

# Lessons from a Bird Feeder

Sometimes the goal isn't to build a perfect project.

Having children was a bonanza for new woodworking opportunities. For my first-born child, I designed and built a crib, changing table and five-drawer dresser. I hand-scraped the projects to achieve the mirror finish I wanted. Everything had to be perfect, which required my wife's cooperation (she didn't go into labor until the night I put the last coat of finish on the crib).

Fast-forward a few years and I'm enjoying building toys for both my children. Each toy became a study in perfection.

One afternoon my 4-year-old son marched up and said, "Dad, let's build a bird feeder!" The engineer's wheels in my mind immediately began to spin furiously. First, I needed to design the perfect bird feeder. Next, it required suitable materials and an outdoor finish good enough to endure the weather.

I turned and looked at the eager child who was thinking this would take no more than 14 minutes. I was panic-stricken. How could I make my child happy and satisfy my own expectations of perfection?

I grumpily walked to the shop. What was I going to do? Then, I did the smartest thing ever. I looked at my son and asked, "What do you want to do?"

He was now in charge. "Dad, we need some wood." I pointed to the large scrap box. Wood started flying until he held up a piece of  $\frac{3}{4}$ " x 6" x 10" mahogany plywood scalloped at both ends. Next he held up a piece of cherry  $\frac{3}{4}$ " x 1" x 6", followed by maple  $\frac{3}{4}$ " x 3" x 8", then mahogany  $\frac{1}{2}$ " x 2" x 8", and finally a piece of walnut  $1\frac{1}{2}$ " x  $1\frac{1}{2}$ " x 10".

I was shaking when I asked, "What's next?"

"Dad, we need to stick these little ones to the big one." I thought dowels, biscuits and glue would be best. I then looked down at the smiling child, gulped hard and realized that hot-melt glue better fits the attention span of a 4-year-old.

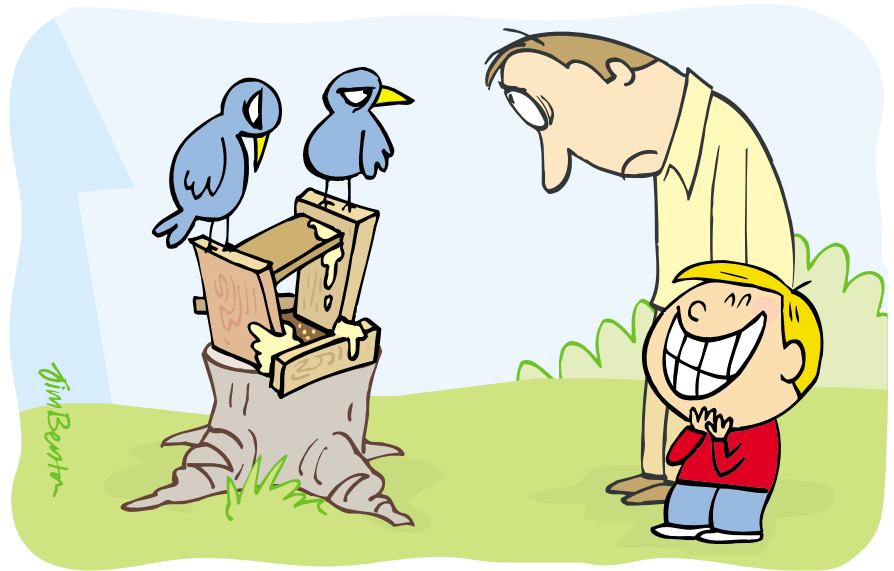

Next I asked, "How should we arrange the parts?" Without a moment's hesitation, he placed the parts into an approximation of a rectangle. I shivered; the parts were different shapes, sizes and species. Didn't this child know I was in pure agony? I looked into the youthful eyes and saw only joy; we were building a bird feeder!

I bravely picked up the demon hot-glue gun and crudely stuck those parts together. I looked at the project and thought, "What have I done? I hope nobody ever sees this!"

I quivered and asked, "What next?"

"We need some birdseed, Dad." I shuddered and thought, "What no finish?" Against my desires, I walked over and carried a huge bag of birdseed over to the workbench. The child vanished into the bag and came out holding a cup of seed, which was proudly dumped into the "monster" piece.

The bird feeder was then promptly marched to a stump in the back yard. My son looked up at me and almost burst with pride. I re-

ceived a big hug and, "Thanks, Daddy." Then he ran away to the next adventure of the day.

I then had a transformation similar to the Grinch when his heart began to grow. I realized that when working with children it's most important to make them happy. Starting and finishing a project within the attention span of a 4-year-old created a happy child. The fact that I thought the result was not good enough to burn was not important.

That was 10 years ago, and it was the start of many fun projects with my children. As they grew, so did their attention spans and expectations. Swords made of dowels taped together became cars, tanks and trains. Band-saw puzzles grew into band-saw boxes. Plywood action-figure silhouettes became intricate scrollsawn Christmas ornaments. An ugly bird feeder grew into an elegant seaman's treasure chest.

The perfectionist in me never died. I just realized my projects must meet my requirements while a child's project must meet a child's requirements.

The greatest gift I could give to a child on that memorable afternoon was happiness, not an extravagant wooden bird feeder. The memories are forever; the bird feeder lasted two weeks. **PW**

by Eric Johnson

*Eric Johnson, a chief engineer for an industrial equipment manufacturing company, started woodworking 25 years ago as a hobby. He enjoys designing and building furniture, big and small.*

# THE LASER DOESN'T DO THE ACTUAL CUTTING. YET.

It's only a matter of time before somebody comes out with a laser cutting tool for do-it-yourselfers. Until then, there's the Craftsman® Circular Saw with LaserTrac™ Technology. And you'll find it's a much easier (and dare we say more fun?) way to cut straight. If you've ever tried to cut a straight line with a circular saw, then you can appreciate how this combination of laser and saw work together.

With the push of a button, a red laser line is projected from the saw onto the material you're cutting, providing you with a foolproof guide for cutting

it straight. And because the laser guide aligns directly with the blade, it's always accurate and never needs to be recalibrated—even when you're cutting bevels of up to 54.5 degrees. To make a long story short, this circular saw gives you table saw

accuracy without the table. Now, some of you are probably thinking this is nothing more than a toy. You'd be well-advised to think again. It boasts a 14-amp, 2 1/3 horsepower motor that turns

a 7 1/4" blade at 5000 rpm, making it one very serious do-it-yourself tool. All this power also makes it ideal for ripping boards on site, whether you're doing a room addition, building a deck or replacing siding. It even comes with a pair of

LaserTrac™ safety glasses which, in addition to protecting your eyes, make it easier to see the laser in bright sunlight. So get your own at a Sears or Sears Hardware Store near you. Order by phone at 1-800-437-9686. Or simply visit us online at [craftsman.com](http://craftsman.com). After all, saws are cool. Lasers are cool. But a saw with a laser, how cool is that?



**SEARS**  
Good life. Great price.

**CRAFTSMAN**  
MAKES ANYTHING POSSIBLE®





# LAGUNA TOOLS



*Simply the best!*

**800.234.1976**

[www.lagunatools.com](http://www.lagunatools.com)

CIRCLE NO. 128 ON FREE INFORMATION CARD.