

8 PROJECTS – 39 PAGES OF IN-DEPTH PLANS INSIDE!

\$80 SUPER-STURDY SHOP TABLE – BUILD ONE THIS AFTERNOON!

FEBRUARY 2003
ISSUE #132

Popular Woodworking

12-VOLT DRILL SLUG-FEST

16 Drills
Duke it Out –
See Who's
Left Spinning

6 RULES FOR
Built-in
Bookcases

Get it Right
the First Time

PLUS

- Simple (and Instant) CD Storage
- Cherry Country Sideboard
- Build a Smoothing Plane

www.popwood.com
\$4.99 U.S. \$7.99 CAN



0 71486 01355 6

WE MADE A DISCOVERY. People Drop Things.



Amazing, But True.

Plates of food, overfilled grocery bags, footballs at crucial moments, and power tools at work. We kept that in mind while designing our new line of cordless power tools. The collar of our Brute Tough™ drill is reinforced with steel. Its Body Armor™ is so durable, you could drop it forty-six feet. Not that you would. But we did. And despite taking a mean bounce off an unforgiving cement, it came up working. We dropped it again. Another forty-six feet, put in the drill bit, and bore a good two inches into cement as payback. Downtime? Not hardly.

See it at boschtools.com

Attorney Alert: Do not try this test at home. Or at work.

CIRCLE NO. 107 ON FREE INFORMATION CARD

© 2004 Bosch Power Tool Corp. 2004

contents

Popular Woodworking

TOOLS AND TECHNIQUES



22 Easy Stop-cuts and Crosscuts

TRICKS OF THE TRADE

Make this simple cam-action block for your table saw to make stop cuts and long crosscuts. Also, make an air cleaner using an attic fan, plus easy fold-up sawhorses.

30 Triton's First U.S. Plunge Router

TOOL TEST

This orange 15-amp monster came out of almost nowhere (Australia, actually) and is packed with features you won't find on many plungers. Also, we review Craftsman's newest 6" jointer and take a peek at Leigh's slick new Frame Mortise and Tenon Jig.



32 Metabo STE 105 Plus Jigsaw

ENDURANCE TEST

Metabo set its sights on Bosch when it came out with the STE 105 Plus jigsaw three years ago. Find out how this sturdy saw fared after some hard knocks in our shop.

36 I-beam Work Island

INGENIOUS JIGS

Need a sturdy worktable? Take a gander at the plywood base of this puppy. Its simplicity belies its strength, which comes from the technology used to build skyscrapers.

By Nick Engler

47 Build Your Own Handplane

With a few files, a drill press and a hammer, you can build an infill smoothing plane from a kit. We built one from Shepherd Tool Co. and took it for a test drive.



62 12-volt Drills

Ignore the hype about 18- and 24-volt drills. You don't need to lug that kind of weight around to build furniture. We test 16 popular and powerful models, and give you a solid education in the finer points of drilling and driving.

84 Table Saw Pattern-cutting

With a two-piece jig you can transform your table saw into a powerful and accurate pattern-cutting machine.

90 Shaper Fences and Jigs

Harness the true power of your shaper by building these dedicated fences that make tricky setups – such as panel-raising – into safe and simple operations.

By Lonnie Bird



Popular Woodworking (ISSN 0884-8823, USPS 752-250) is published seven times a year in February, April, June, August, October, November and December by F&W Publications Inc. Editorial and advertising offices are located at 4700 E. Galbraith Road., Cincinnati, OH 45236; tel.: 513-531-2222. Unsolicited manuscripts, photographs and artwork should include ample postage on a self-addressed, stamped envelope (SASE); otherwise they will not be returned. Subscription rates: A year's subscription (7 issues) is \$28; outside of U.S. add \$7/year • Canada Publications Mail Agreement No. 40025316. Canadian return address: 2744 Edna St., Windsor, ON N8Y 1V2 • Copyright © 2003 by Popular Woodworking. Periodicals postage paid at Cincinnati, Ohio, and additional mailing offices. Postmaster: Send all address changes to Popular Woodworking, P.O. Box 5369, Harlan, IA 51593 Canada GST Reg. # R122594716 • Produced and printed in the U.S.A.

Cold,



hard cash.



\$50 or \$100? It's your choice.

Buy one of 12 qualifying machines and we'll reimburse you \$100 when you purchase any additional JET, Powermatic, or Performax machine OR up to \$50 on the purchase of our accessories. Pick up your second machine or accessories immediately — or until March 31, 2003.

Look for the green tags on the industry's hottest sellers at participating dealers. Cold, hard cash. It's an easy choice.

Offer valid October 1, 2002 through March 31, 2003. For promotion details, visit your dealer, see our website at www.jettools.com, or call 1-800-274-6848.





ON THE COVER

12-volt drills can handle almost any chore in the woodshop. But some do a better job than others. Find out who is the champion (and who choked) in our test of 16 models.

Cover photo by Al Parrish

IN EVERY ISSUE

10 **Out on a Limb**
Get More From Your Woodworking

12 **Letters**
Mail from readers

16 **Q & A**
We answer readers' most difficult questions

99 **Caption the Cartoon**
Win a Freud jigsaw

100 **Flexner on Finishing**
The Challenge of Cherry

104 **Out of the Woodwork**
The Old Man and the Ceiling
by Ben Knebel

PROJECTS

40 **Kentucky Sideboard**

This vernacular furniture style is brought to life with subtle inlay on the legs and drawers. Construction is simple; the results are beautiful.

By Warren A. May

50 **Garage Golf Caddy**

Get those clubs out of the corner of your closet. A weekend in the shop gains you a handy place to store everything you need for the links.

By Troy Sexton



54 **Built-in Basics**

Transform any bookcase design into a built-in that will hug the wall, sit perfectly level and survive the occasional climbing child. It takes just a little planning and a few tricks.

72 **Marble Maze Puzzle**

With just a couple simple jigs and stop blocks, you can build one or 100 of these ingenious puzzles.

By Joe Hurst-Wajszczuk

78 **Knockdown Media Center**

Through the miracle of biscuit joinery, you can make an armoire or entertainment center that can be knocked down in minutes to fit in a car's trunk.

By Jim Stack

86 **Simple CD Storage**

Forget the cheesy plastic inserts that hold CDs in your cabinets. We show you how a perfectly sized dado can turn any board into useful media storage.

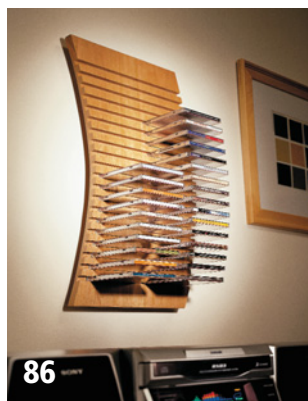

**Drop it
in, lock
it down,
you're
ready for
anything.**



**Make your
workshop work
harder with
Tool Dock™.**

**Special
Manufacturer's
Rebate!**

Get \$20 back from Waterloo Industries when you purchase one modular Tool Dock™ workstation. Visit www.tooldock.com and click on the special rebate button, or call for details.

Check our website for suggested retail prices.

Customize your shop to fit your current home improvement project with the Tool Dock™ modular workshop system. Set-up and changeover is quick and easy thanks to the innovative tool-mounting inserts. Accessories, jigs and supplies are stored close at hand, and built-in dust collection features make clean-up a breeze. All this in solid, 18-gauge steel cabinets...**The dream shop is here.**



The Modular Workshop



Tools not included.



Now available through these stores!



For more information or an outlet near you...

www.tooldock.com

1-866-866-5362 (Toll-free call)

CIRCLE NO. 154 ON FREE INFORMATION CARD.

©2002 Waterloo Industries, Inc., Waterloo, Iowa, USA Tool Dock™ is a trademark of Waterloo Industries, Inc. Patent pending.



For the serious woodworker and professional.

ProTop
COMPLETE

(p/n FTB400)

ProTop Complete floor standing system includes our 36" **ProFence** router fence, a **ProTop Standard** router top and a **ProTop Cabinet**. (Shown with optional Drawer Bank and Cab-Loc mobile leveling system)



ProLift
28

Router Adjustment System (p/n PL1002)

Perfect for the Porter-Cable 7518 router and 4.2" diameter fixed base router motors (except plunge routers). Fits 3.5" dia. and smaller fixed base motors with adapters.

MADE IN
USA

benchdog.com

FREE CATALOG 1-800-786-8902

CIRCLE NO. 105 ON FREE INFORMATION CARD.

Popular Woodworking®

February 2003, Vol. 23, No. 1
popularwoodworking.com

Editorial Offices 513-531-2690

Editor & Publisher **Steve Shaney**
ext. 1238 • steve.shaney@fwpubs.com

Art Director **Linda Watts**
ext. 1396 • linda.watts@fwpubs.com

Senior Editor **David Thiel**
ext. 1255 • david.thiel@fwpubs.com

Senior Editor **Christopher Schwarz**
ext. 1407 • chris.schwarz@fwpubs.com

Assistant Editor **Kara Gebhart**
ext. 1348 • kara.gebhart@fwpubs.com

Project Illustrator **John W. Hutchinson**

Photographer **Al Parrish**

Contributing Editors

Nick Engler
Bob Flexner
Glen Huey
Scott Phillips
Troy Sexton

President-Magazines **Roger Case**

Executive Vice President **Jim Gleim**

Editorial Director **David Fryxell**

CIRCULATION

Lynn Kruetzkamp, Group Circulation Manager
Jennifer Shaffer, Circulation Manager

PRODUCTION

Barbara Schmitz, Vice President
Vicki Whitford, Production Supervisor

ADVERTISING

Advertising Director

Don Schroder

331 N. Arch St., Allentown, PA 18104
Tel. 610-821-4425; Fax 610-821-7884
d.schroder@verizon.net

Classified Advertising Sales

Joan Wright, Tel. 800-388-1820
jwrightperry@aol.com

Advertising Production Coordinator

Debbie Thomas, Tel. 513-531-2690 ext. 1219
debbie.thomas@fwpubs.com

SUBSCRIPTION SERVICES Subscription inquiries, orders and address changes can be made at popwood.com (click on Subscriber Services). Or by mail: Popular Woodworking, P.O. Box 5369, Harlan, IA 51593 or call 515-280-1721. Include your address with all inquiries. Allow 6 to 8 weeks for delivery.

NEWSSTAND DISTRIBUTION Curtis Circulation Co., 730 River Rd., New Milford, NJ 07646

ATTENTION RETAILERS:

To carry Popular Woodworking in your store, call RetailVision at 800-381-1288 ext. 6050 or write RetailVision, 23 Pond Lane, Middlebury VT 05753.

Back issues are available for \$7 (\$9 Canada; \$11 other foreign). Send check or money order to: Popular Woodworking/F&W Publications Products, P.O. Box 2031, Harlan IA, 51593; or call 888-419-0421. Please specify publication, month and year.

ROUT WITH THE BEST

See why Amana Tool® router bits are the professional's choice!
SUPERIOR PERFORMANCE • LARGEST SELECTION • BEST VALUE

Amana Tool®, the world's most respected maker of premium-quality cutting tools, offers more than 1,200 different router bits for every conceivable routing job. Every Amana Tool® router bit is precision-machined from a single rod of virgin tool steel and tipped with high density micro-grain carbide, then ground to the highest tolerances in the industry, on state-of-the-art grinding equipment.

The result? Amana Tool® bits stay sharp longer and cut smoother than any other bit on the market, at prices that seem too low to be true! And, every Amana Tool® bit over 5/8" diameter meets the rigid European "BG" specifications for anti-kickback safety. No fancy paint colors or misleading claims—just quality engineering and superior performance!



But, don't take our word for it—discover the Amana Tool® difference for yourself.



Amana Tool®

FOR OUR NEW CATALOG OR A DEALER
NEAREST YOU CALL 1-800-445-0077.

Visit our web site at www.amanatool.com

You may order directly from one of our on-line dealers or call us toll-free at 1-800-445-0077 for our latest catalog.

CIRCLE NO. 101 ON FREE INFORMATION CARD.



PRESENTING THE LONG AWAITED 10" LEFT-TILTING TABLE SAW

SEE THIS FINE MACHINE AT AN AUTHORIZED DEALER NEAR YOU!

NEW!

This saw will definitely take center stage in any shop. We've included two large precision ground cast iron wings, a jumbo miter gauge with a patented adjustment feature, and a powerful 3 H.P. motor with a triple belt drive system. The SHOP FOX® Classic Fence with a 26" rip capacity provides a compact and sturdy means for dependable and accurate ripping. (Longer rails are available.)

W1677
SHOP FOX®
3 HP Left-Tilting Table Saw



- LEFT-TILTING TABLE SAW**
- ◆ MOTOR: 3 H.P., SINGLE-PHASE, 220V
 - ◆ DRIVE: TRIPLE BELT
 - ◆ TABLE SIZE: 40 1/8" x 27" WITH WINGS (INCLUDED)
 - ◆ TABLE: PRECISION GROUND CAST IRON WITH T-SLOTS
 - ◆ ARBOR: 5/8" (CAN ACCEPT DADO SET AS WELL)
 - ◆ TABLE SAW INSERTS: 2 INCLUDED (STANDARD AND DADO)
 - ◆ MITER GAUGE: HEAVY-DUTY CAST-IRON
INCLUDES PATENTED ADJUSTABLE MITER BAR
 - ◆ SWITCH: HEAVY-DUTY MAGNETIC
 - ◆ MAX. BLADE HEIGHT: 3"
 - ◆ WEIGHS APPROX. 450 lbs.

2
YEAR
WARRANTY

403801958R

1-800-840-8420

Technical Support: 360-734-3482

sales@woodstockint.com

www.woodstockinternational.com

CALL TODAY FOR THE NAME OF A DEALER NEAR YOU



Get More From Your Woodworking This Year

Resolutions are a good idea that usually don't work, so I tend not to make any. But it's human nature to reflect on the past and look to the future this time of year, and I consider that a beneficial exercise.

I've assembled a list of things to do in the coming year that will help you get more out of your woodworking. Some are just little things, some will enrich your woodworking soul. Any one of these will help you get more from your woodworking. Here goes:

- Build a completely different kind of project, such as a band-sawn box.
- Make a small project from an interesting chunk of cordwood or downed tree in your neighborhood.
- Find a woodworking club in your area and attend a meeting.
- Try something new such as chip carving, turning or inlay work.
- Read at least three woodworking books. Choose one that will help you with your methods of work. Choose another that will inspire your work. Select a third about a woodworker or furniture designer.
- Buy a new tool or machine, then learn all there is to know about it.
- Clean up and organize your shop. Throw away all those things you've been saving for

more than two years that you haven't used yet – because you never will.

- Build a shop project that will organize your tools, hardware or scrapwood.
- Learn to tune up, sharpen and use edge tools: chisels, handplanes and scrapers.
- Spend time in the shop with a child or friend. You just might give the gift of the hobby you enjoy so much to another.
- Donate a project of yours to charity.
- Attend a woodworking show. They are a great way to learn at free demonstrations, see hundreds of new tools and rub elbows with people who share your interests.
- Take a woodworking class for an evening, a weekend or a week.
- Improve your finishing. Pick one project and vow to give it the best finish you've ever done. Work at it and remember you'll get out of it what you put in.
- Renew your subscription to *Popular Woodworking*. OK, this is a commercial plug. But really, we have some great new contributors coming your way in 2003 that you won't want to miss. **PW**

Steve Shanesy
Steve Shanesy,
Editor and Publisher

WOODWORKS SHOWS A HIT

Thousands of woodworkers have jammed through the turnstiles, some from hundreds of miles away, at the WoodWorks shows in Novi, Mich., and Ft. Washington, Penn. The next show is Jan. 24-26 in Ontario, Calif.

Hundreds of exhibitors, many offering great deals on tools, plus free demonstrations by top woodworkers and turners have made these shows a real success. Visit woodworks2002.com for more information.



Popular Woodworking is proud to sponsor these events, and the editorial staff has enjoyed meeting many of the readers who stopped by our booth. We'll all be at the Ontario show so stop in and say hello. Next issue we hope to announce a show schedule for 2003.

Frank Klausz demonstrates sharpening during the Ft. Washington, Penn., show.

CONTACT INFORMATION

Steve Shanesy

Editor & Publisher

Specialties: Projects, techniques, article and project selection
513-531-2690 ext. 1238
steve.shanesy@fwpubs.com



David Thiel

Senior Editor

Specialties: Projects, new products and tools, tricks of the trade
513-531-2690 ext. 1255
david.thiel@fwpubs.com



Christopher Schwarz

Senior Editor

Specialties: Author liaison, web site, projects, hand-tool techniques
513-531-2690 ext. 1407
chris.schwarz@fwpubs.com

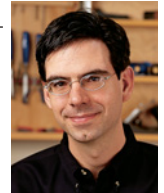

Kara Gebhart

Assistant Editor

Specialties: Special issues, author liaison, copy editing
513-531-2690 ext. 1348
kara.gebhart@fwpubs.com



Linda Watts

Art Director

Specialties: Magazine and cover design, photo direction
513-531-2690 ext. 1396
linda.watts@fwpubs.com

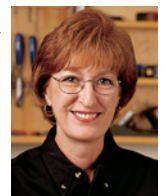

Our Privacy Promise to You

We make portions of our customer list available to carefully screened companies that offer products and services we believe you may enjoy. If you do not want to receive offers and/or information, please let us know by contacting us at: List Manager, F & W Publications, 4700 E. Galbraith Road, Cincinnati, OH 45236

SAFETY NOTE

Safety is your responsibility. Manufacturers place safety devices on their equipment for a reason. In many photos you see in *Popular Woodworking*, these have been removed to provide clarity. In some cases we'll use an awkward body position so you can better see what's being demonstrated. Don't copy us. Think about each procedure you're going to perform beforehand. Safety First!

SHIFT TO FULL POWER.™

Makita®

MFORCE™



**NEW
CORDLESS DRILL SERIES**

FREE

**MV
MECHANIX WEAR
GLOVES**

INCLUDED IN EACH KIT

\$40.00 Retail Value



MFORCE™ DRILL SERIES • 18V, 14.4V, 12V • 1-800-4MAKITA • MAKITATOOLS.COM

PERFORMANCE

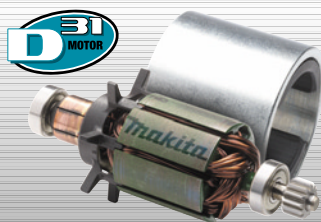

Two-Piece D-31 motor with dual ball bearings for longer motor life

DURABILITY



All metal gear transmission creates efficient power

POWER



Shift-Lock™ Drive System instantly shifts from "drill" to "driver"

RUN TIME



2.6Ah (Ni-MH) batteries outlast Ni-Cd with no memory effect

The Delta Edge

New from the company on the cutting edge of innovation.



Delta Industrial 12" TwinLaser™ Compound Miter Saw

Bright TwinLaser™ cut lines clearly indicate both sides of the blade kerf for faster and more accurate cuts. Plus a powerful 15 amp motor provides power for any job.



Delta Industrial 1/2 HP Mortiser

Featured with easy and open access to the drill chuck, adjustable fence and holddown, and a large cast-iron base with center through hole make this mortiser perfect for any shop.



Delta Industrial 14" Band Saw

Feature-packed with a powerful 1 HP, 120V motor, enclosed stand, 9-spoke wheels, large 16" x 16" tilting cast-iron table, and quick-release tension lever.

For complete product specifications on these and other Delta innovations visit deltamachinery.com.



Your achievement. Our tools.

CIRCLE NO. 115 ON FREE INFORMATION CARD.

LETTERS

Carnival Trick With Your Tape Measure

Use Your Tape to Measure Your Age

Reading the letter about left-handed tape measures in the December 2002 issue reminded me of a trick you can do with a tape measure that will fascinate your family and your woodworking friends.

Pull the tape out and double it over, placing the end of the tape on number 102 (for the year 2002). Now look back down the tape to the year you were born, which in my case would be 32 (for 1932). On the other side of the tape you will find your age, which in my case is 70. Both my kids and my grandson have found this a fascinating "trick."

Ed Merritt
Skyline, Alabama

More Thoughts on Which Hand Tape Measures Should be Held With

I read the letter in the December 2002 issue, and I had some thoughts on why the numbers read reversed on tape measures.

I realize that most people are probably right-handed. Yet, you will notice that most people grab the tape in their left hand. When one does this, the numbers are upside down. But, it can also be presumed that people who are right-handed are stronger in their right hand. If that's the case, then perhaps the designers intend for the ruler or tape to be held in place with the stronger hand and the mark made with the weaker hand.

This could be an advantage when you're in an inconvenient position, such as on a rooftop or leaning over a wide board. It would seem more important to hold the rule steady and then make a mark, especially if you're trying to keep the hook from moving over a long distance. This could also apply to a folding ruler; all the left hand would have to do is to make a small pencil mark. Also, when retracting the hook, the right thumb on a right-handed person might have a little more control on the lock button.

And you'll notice that the belt hook is

on the left side of the tape case. If you're right-handed, you'll invariably try to hook it on the right side of your belt.

Ed Williams
Elkhorn, Wisconsin

The Panel-cutting Sled Could be Dangerous – So Move the Fence

In the October 2002 issue you have plans for a panel-cutting sled for your table saw. In the article you have the fence at the front of the sled. This could be dangerous.

When you have the fence at the back of the sled, the rotation of the blade will help hold the stock/panel up against the fence. In the process, this will help keep your work lined up nice and straight (with less danger of a kickback).

A variation on the sled can be used to cut dados in stock that is too narrow to run up against the fence. Build a standard sled (fence to the back) with the base cut off to accommodate a stacked dado head ($\frac{3}{4}$ " wide). On the fence, clamp a stop block and then you can make a number of parts complete with perfectly matching dados.

Donald Motter
via the internet

Editor's note: I've been cutting panels this way for years without incident, and I consider

continued on page 14

WRITE TO US

Popular Woodworking welcomes letters from readers with questions or comments about the magazine or woodworking in general. We try to respond to all correspondence. Published letters may be edited for length or style. All letters become the property of Popular Woodworking. How to send your letter:

- E-mail: popwood@fwpubs.com
- Fax: 513-891-7196
- Mail carrier:
Letters • Popular Woodworking
4700 E. Galbraith Road, Cincinnati, OH 45236



*You must be very proud.
Is this the first time you've hand-cut dovetails?*

Cradle courtesy of Norm Abrams.

Your woodwork gets undivided attention. Inspired creations usually do. And Delta is proud to help by making the best tools for the job. Any job. So get a tool known for innovative design and reliability. Get a Delta. For a full-line catalog call 800-438-2486 (US), 800-463-3582 (Canada), or visit deltamachinery.com.



 **DELTA**[®]
Your achievement. Our tools.

CIRCLE NO. 116 ON FREE INFORMATION CARD.

WOODLINE USA™ OFFERS YOU MORE... LIFETIME WARRANTY / GUARANTEED LOWEST PRICE

30

Piece PROFESSIONAL SET

All Woodline USA Products Feature
Tough Micro Grain Carbide

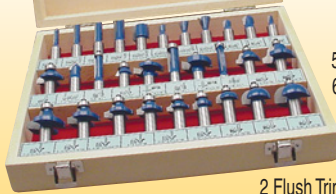

Includes:

- 5 Straight Bits
- 6 Roundovers
- 3 Dovetails
- 3 Core Box
- 3 Cove Bits

- 2 Flush Trim, 1 Panel Bit
- 2 Roman Ogee, 2 Slot Cutters, 1 "V" Groove

- 1 Chamfer and 1 Bevel Trim Bit

SUPER BUY

WL-2010 **OUR PRICE ONLY \$109** set

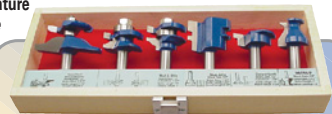

6 Piece CABINET DOOR SET

- 1/2" Shank Router Bits
- 2-pc Rail & Stile (Roman Ogee) • Drawer Lock
- 3 1/4" D Panel Raiser (Ogee) • Door Lip • Glue Joint

WL-2020-1 \$175 VALUE

OUR PRICE ONLY \$119 set



WL-1505 \$279 VALUE

OUR PRICE ONLY \$179 set

5 Piece MOULDING SET



1/2" Shank Router Bits WL-2011 \$175 VALUE

OUR PRICE ONLY \$99 set

13 Piece DOVETAIL SET



WL-2014 \$125 VALUE

OUR PRICE ONLY \$49 set

9 Piece MASTER DADO SET



WL-2030 \$89 VALUE

OUR PRICE ONLY \$39 set

5 Piece COVE SET



WL-2015 \$99 VALUE

OUR PRICE ONLY \$49 set



15 Piece 1/2" SHANK SET

Includes:

- Chamfer • Cove = 1/2"R, 3/8"R, 1/4"R
- Roundover = 1/2"R, 3/8"R, 1/4"R
- Roman Ogee = 1/4"R
- Straight Bits = 3/4"R, 1/2"R, 1/4"R
- 1/2" Dovetail • 1/2" Roundover • 1"CL Flush Trim • Rabbet Bit

WL-2022 for 1/2" or WL-2021 for 1/4" SHANK SET

OUR PRICE ONLY \$59 each set



5 Piece DOVETAIL SET

- 14" 3/4" • 14" 5/8"
- 8" 1/2" • 14" 1/2"
- 14" 3/8"

1/2" Shank Router Bits

WL-2017

\$30 VALUE

OUR PRICE ONLY \$19 set

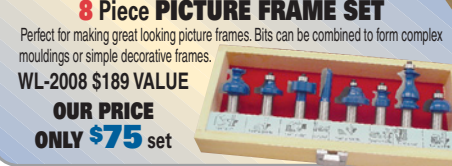

8 Piece PICTURE FRAME SET

Perfect for making great looking picture frames. Bits can be combined to form complex mouldings or simple decorative frames.

WL-2008 \$189 VALUE

OUR PRICE ONLY \$75 set



3 Piece CABINET DOOR SET

- 1/2" Shank Router Bits • 2-pc Roman Ogee Rail & Stile
- 3 1/4" Panel Raiser

WL-2019-1 \$129 VALUE

OUR PRICE ONLY \$69 set



**GREAT ROUTER BITS AND SHAPER CUTTERS
BEST SELECTION / BEST PRICE!
ORDER TOLL FREE**

1-800-472-6950

WOODLINE USA • P.O. BOX 298 • TEMECULA, CA 92593

- INDIVIDUAL BITS ALSO AVAILABLE • ALL MAJOR CREDIT CARDS
- PRIORITY SHIPPING: \$3.75 FOR UP TO \$99. / \$4.75 FOR \$100.+
- MOST ITEMS IN STOCK • SAME DAY SHIPPING

PREMIUM CARBIDE

- Tough Micro Grain Carbide
- Euro Anti-Kickback Design
- Super-Slick Non-Stick Finish
- Super Low Prices

FREE CATALOG
See our great selection of Bits and Cutters
1-800-472-6950

QUALITY Guaranteed

LETTERS

continued from page 12

it no more dangerous than using your stock miter gauge. As long as you keep firm pressure between the fence and the work it's a simple operation. If you fail at keeping a firm grip – whether it's a crosscut with your miter gauge or this jig – you're likely to have trouble.

In fact, I got the idea for the jig from my table saw's manual that tells you to turn your miter gauge around to cut wide panels. And if a manufacturer will put this operation in the manual in these litigious times, I cannot imagine it being one that has caused trouble.

Please don't think I'm making light of your concern. But I consider this operation quite safe and am happy to recommend it to woodworkers. By the way, that's a good idea for cutting dados. I'll give it a try.

—Christopher Schwarz, senior editor

How Do I Make My Bench Mobile?

Your wonderful article ("Workbench for Power Tools," August 2002) has inspired me. It is very close to the workbench I will build. The main difference will be that in my small garage everything must be mobile. My concern is the stability of the bench when on wheels. Do you have any thoughts on how best to do this?

Michael Van Cleave
via the internet

Editor's note: I've had a couple people ask me this question. There is a mobile base made by Delta that allows you to create a custom size using hardwood runners. Also, Woodcraft (800-225-1153) sells sets of retractable feet that can be bolted to any machine or leg.

I need to investigate other options myself. If you come up with a good solution, please let me know and I'll share it with our readers. PW

— Christopher Schwarz, senior editor

CORRECTIONS

Popular Woodworking corrects all significant errors. For a list of corrections to the magazine (or to report one), visit our web site at: popwood.com/features/mag.html

In the "Nesting Tables" article in the December 2001 issue, one of the dimensions is incorrect. In order to provide for 1/4" clearance between the largest table and the medium table, the tabletop's length (as listed in the cutting diagram, and the text as well) should be 22 1/4", and not 22" as listed in the article.

NEW

Precision Router Lift

"finest pitch, finest adjustment"
call for free catalog



Woodpeckers

1.800.752.0725

www.woodpeck.com

CIRCLE NO. 167 ON FREE INFORMATION CARD.

New! All★Pro™

Professional Series Band Saw Blades

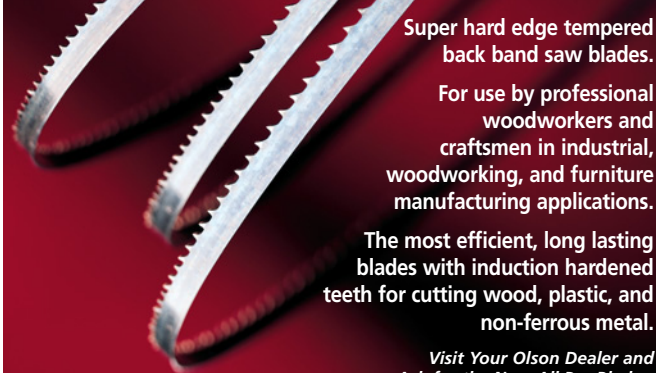

Super hard edge tempered
back band saw blades.

For use by professional
woodworkers and
craftsmen in industrial,
woodworking, and furniture
manufacturing applications.

The most efficient, long lasting
blades with induction hardened
teeth for cutting wood, plastic, and
non-ferrous metal.

Visit Your Olson Dealer and
Ask for the New All Pro Blades.

Dealer Inquiries Welcome!
Call: 203.792.8622

OLSON®

THE OLSON SAW COMPANY

16 Stony Hill Road, Bethel, CT 06801 • www.olsonaw.com
Manufacturers of Fine Quality Saw Blades Since 1918

CIRCLE NO. 141 ON FREE INFORMATION CARD.

JDS AIR-TECH and Dust-Force

When only the **Best** will Do!



\$289.00

Model 750-ER



JDS, the leader in quality air filtration products, introduces the ultimate air cleaner for your shop (**Model 750-ER**). This remote controlled unit will clean the air in a 30'x30'x8' shop once every ten minutes. For larger areas the models 8-12, 10-16, and 2400 are available. To remove odors, fumes and smoke, order our optional charcoal filter.

Model 750-ER

When only the **Best** will Do!

- LCD Remote Control with speed and timer function
 - Highest Maximum Air Flow in its Class 1,050 CFM (750 CFM Filtered Air)
 - 95% ASHREA Tested main filter (91% Efficiency at 1 micron - 99% at 5 microns)
 - Washable Electrostatic Pre Filter
- With ten year manufacturer's warranty

To place an order or for the dealer nearest you call us toll free. 1-800-480-7269



Put the force to work in your shop...

Our new 1.5 HP **Dust-Force** is the perfect addition to our award winning line of air filtration units. Powerful, portable, and ready to work for you, the **Dust-Force** will make your shop a cleaner, healthier, more productive environment.

\$299.00

Specifications

Motor..... 1.5 HP
 Max CFM..... 1250
 Fan..... 11"
 Inlet Dia..... 1-5"/2-4"
 Bag Capacity..... 42 gallons
 Decibels..... 67-77
 Electrical..... 110/220
 ↳ Switch Prewired for 110V

Another quality product from

www.thejdscompany.com

CIRCLE NO. 124 ON FREE INFORMATION CARD.

Why Not Sharpen Disposable Knives?

Experience fine woodworking tools in your shop, direct from Woodcraft on the web.



When woodworking is your passion, fine woodworking tools, accessories, and expert advice from Woodcraft can help take your woodworking to the next level.

WOODCRAFT
Helping You Make Wood Work®

For your local woodcraft store, visit www.woodcraft.com, or for a free catalog call 800 542-9115

Dept.03PW01BD

CIRCLE NO. 164 ON FREE INFORMATION CARD.

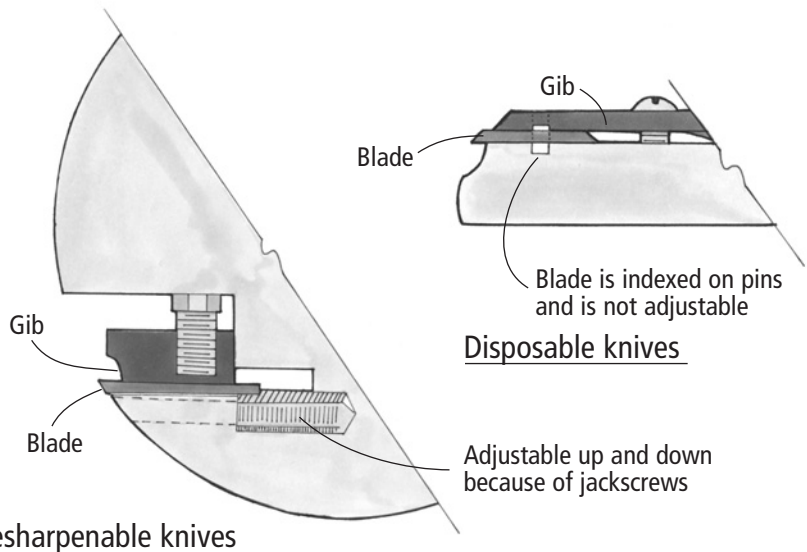

Resharpenable knives

Can You Resharpener the Disposable Blades for Portable Planers?

I've built many of the projects and jigs published in your magazine with great results. One I have particularly enjoyed is the Scary Sharp Jig for plane blades and chisels (June 2000 issue). I can see my reflection on the blades after I'm done – cool!

I own a Delta 12" planer with double-sided disposable blades. I would like to sharpen them with sandpaper but they don't fit in the Scary Sharp Jig. Any ideas?

Ben Moll
via the internet

I can't recommend sharpening disposable blades, though I admire your thriftiness. The problem is that disposable blades are not adjustable once installed in the cutterhead. This makes replacing the blades a snap but makes them impossible to regrind. Any grinding will change their width slightly, and without a mechanism to adjust them in the head, they'll be out of alignment with each other.

You could, however, hone the knives a bit a time or two. After that I suggest you simply spend the cash to replace them.

— David Thiel, senior editor

How Can I Remove Rust From My Planes Without Destroying Their Value?

I just finished reading your article on metal-bodied jack planes in the April 2002 issue – a very interesting article. I have three jack planes that I want to fix up to use. I was wondering how I can clean the metal on the sides of the planes and what to put on them to protect them from rust. I do not want to ruin the value of the planes, but I also want to start using them more.

Gerald Cudmore
via the internet

Unless your planes are collectibles, such as the Stanley Bed Rock series of planes, I wouldn't worry too much about destroying their value. Jack planes are as common as dirt for the most part and should be in the shop, not on a shelf.

The most non-invasive (and best way) to remove rust is to try using electrolysis. It's a fairly simple procedure you can do at home with a battery charger, ammeter and baking soda. For a complete explanation of this procedure, visit:

<http://users.interconnect.net/nlindsey/rusty2/electrolysis/electrolysis.htm>

I've seen many planes treated using this procedure and the results are quite amazing. A more

continued on page 18

can you feel the vibration?

...neither can he.

The NOVA DVR 3000 with the revolutionary new Digital Variable Reluctance motor produces the smoothest, most efficient turning platform yet possible.

Since the DVR has no belts or pulleys, turners are saying this lathe is a whole new experience in turning smoothness.

You'll find the NOVA DVR 3000 exclusively at Woodcraft.

Whether you're a beginner or a master woodworker, experience the finest in woodworking tools, power tools, and education from our catalog, online at www.woodcraft.com, and at your local Woodcraft store.



WOODCRAFT
Helping You Make Wood Work[®]

fine woodworking tools, accessories, expert advice

The Toughest Glue On Planet Earth

You're beyond simple yellow glues and you don't want a different bottle of glue for every project. You want Gorilla Glue®. Bonds wood, stone, metal, ceramics and more. Incredibly strong and 100% waterproof.



for retailers near you:
www.gorillaglue.com
1-800-966-3458

Q&A

continued from page 16

low-tech and aggressive approach is to simply use sandpaper or a belt/disk sander.

I protect my planes with camellia oil, which is available from Lie-Nielsen Toolworks (800-327-2520 or lie-nielsen.com). It goes a long way and does an excellent job of preventing rust on all my hand tools.

—Christopher Schwarz, senior editor

Why Won't My Portable Planer's Rollers Grip My Lumber?

I have a question regarding my portable planer. Sometimes the rubber rollers do not seem to grip the wood well when passing stock under the cutterhead. Is there something that can be done to rejuvenate the rollers? The rollers have a small amount of sawdust built up on them.

Tim Dewberry
Fullerton, California

I'd start by getting the sawdust off. Wipe the rollers down with a coarse cloth. If that doesn't do it, try a mild solvent (such as naphtha) that won't degrade the rollers. The sawdust is likely your problem as the rollers themselves should prove adequate for many years. You also should try to improve the slickness of the tables using a commercial spray-on lubricant, or just some paraffin wax. This will reduce the friction on the tables, making the rollers work less.

—David Thiel, senior editor

When Should I Use an Oil Finish?

I am installing an Andersen In-swing French door with an all-oak interior finish, and I'm trying to decide how to finish it. I was originally considering Minwax Antique Oil Finish or the company's Tung Oil Finish. Or should I consider something that will cure hard to protect the finish from kids, water, spills, stains, etc?

From reading your magazine I understand that wiping varnish (thinned varnish) will cure hard. An oil/varnish blend (oil with a resin) dries soft. I would really appreciate some help and guidance.

Brian Klodaski
via the internet

Many of the woodworking magazines and some of the manufacturers represent oil/varnish blends as oil with resin. This is misleading and makes the product seem mysterious. It's simply oil (usu-

ally boiled linseed oil) mixed with varnish and thinned with paint thinner. One common natural resin that you should be familiar with is amber. You put amber in linseed oil and it just sinks to the bottom.

Traditional varnishes were made by cooking linseed oil and natural resins. This changed the chemistry, like heating yeast and flour, and made varnish – which cures hard. Any product with oil mixed in (rather than cooked in) cures soft, so the excess has to be wiped off or the surface won't be functional. Modern varnishes are made synthetically to imitate the old cooked varnishes.

As far as when each is appropriate, that's a personal preference. I can't tell you when to use these finishes for the same reason I can't tell you when you should use dowels and when you should use mortise-and-tenon joints. In the case of finishes, there's too much aesthetics involved. You might like the look of a thin, satin oil finish more than a glossier film-building finish. You might also like the ease of applying oil – wipe on and wipe off. You can't mess it up.

I can say that the thicker you build a finish (within limits) the more protective it will be, and that oil finishes aren't very protective because they are too thin.

But then you're finishing doors. How much protection do you need?

You can always try the oil and then coat it over with something else – wiping varnish or polyurethane (or anything for that matter) – if you decide the oil isn't protective or durable enough. Just be sure the oil has had a week or so to fully cure. **PW**

—Bob Flexner, contributing editor

WRITE TO US

Every day we get questions from readers on all subjects about their woodworking. Some are letters; many are e-mail messages. We are more than happy to share our woodworking experience with you by answering your questions or adding some clarity to whatever aspect of your craft you are unsure about. In addition to the hundreds we answer privately every month, we want to share the best questions here with readers.

Send your questions via e-mail to popwood@fwpubs.com. Or send a note by mail to: Popular Woodworking, Q&A, 4700 E. Galbraith Road, Cincinnati, OH 45236.

DON'T JUST IMAGINE IT ROUT IT!

with Viper® Carbide Router Bits

Over 400 profiles to choose from



Straight

Forming



Grooving



Laminate & Trim



Bring out the beauty of the wood in your projects. Signs, picture frames, moldings, furniture, cabinet doors. Simple or complex, if you can imagine it, you can rout it with Viper router bits. With finely honed RazorSmooth carbide edges, high-strength brazing, precisely machined anti-kick bodies and anti-stick coating, Viper consistently delivers clean, smooth, burn-free cuts. And Viper bits are made with care in West Jefferson, NC, by folks who know woodworking.

T h e A r t o f R o u t i n g

WOODTURNERS!

Call now for a **FREE** copy of our **128 page catalog!**

- **Best Selection**
- **Best Service**
- **Satisfaction Guaranteed!**

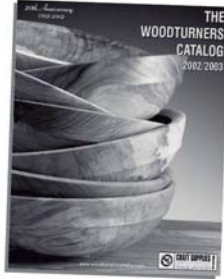

www.woodturnerscatalog.com

CRAFT SUPPLIES USA
1-800-551-8876

CIRCLE NO. 112 ON FREE INFORMATION CARD.

TIMBER WOLF BAND SAW BLADES FROM PS WOOD MACHINES

Distributors of Gschwind group

These Blades:

- guaranteed welds for life!
- run cooler, last longer, and do not wander!
- are made from silicon carbon steel, and have milled teeth
- produce a thin kerf.

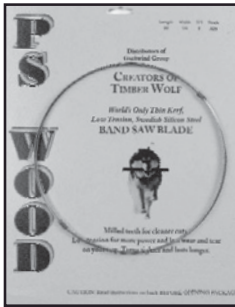

Call for more information at (412) 831-5402 or **ORDER TOLL FREE: (800) 939-4414**
PS Wood Machines, 3032 Industrial Blvd., Bethel Park, PA 15102
www.pswood.com

CIRCLE NO. 145 ON FREE INFORMATION CARD.

When It Comes To DH Kilns,

There's Only One Original.

Whether you're drying 300 board feet or three million, you'll get the performance and results you need with the world leader in dehumidification lumber drying: Nyle Dry Kiln Systems.

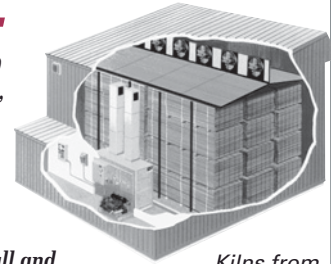

Kilns from 300 to 350,000 BF

Nyle kilns cost less to install and operate than conventional kilns, and our patented technology gives you exact control of kiln conditions for superior drying quality. With a Nyle system, DH drying is an economical, high-quality option for even the largest drying operation.

For **FREE** facts on a system for your business, go to:

www.nyle.com

nyle
DRY KILN SYSTEMS

(207) 989-4335
FAX (207) 989-1101
1-800-777-6953



P.O. Box 1107 Bangor, Maine 04402-1107

Nyle DH Kilns

- Use 50% to 60% less energy than conventional kilns
- Provide outstanding drying performance
- Give you unbeatable quality and reliability

CIRCLE NO. 140 ON FREE INFORMATION CARD.

The Easy Rout.

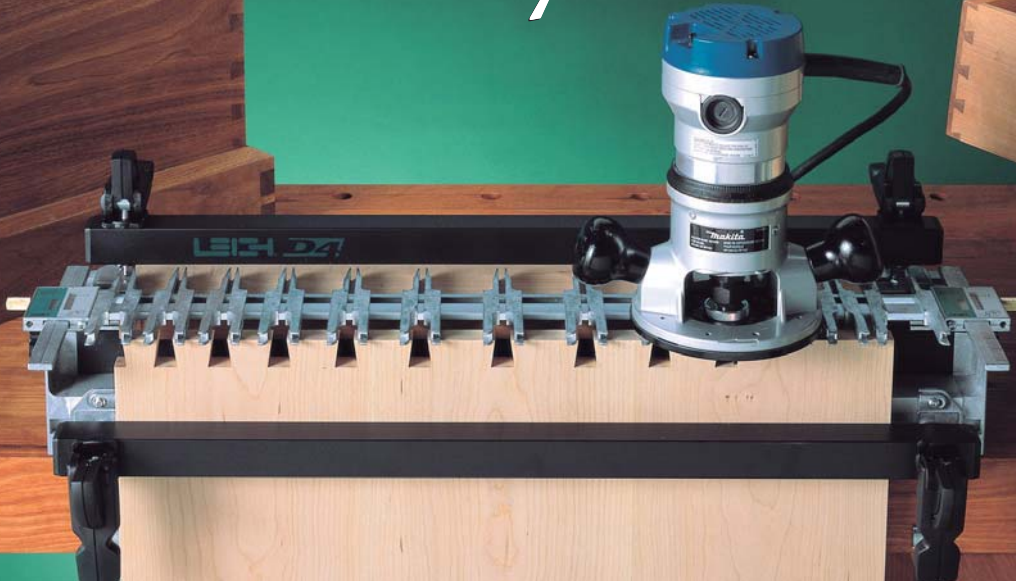

The Leigh Dovetail Jig has it all. Hobbyist or professional, the Leigh D4 Dovetail Jig will ensure you create your best work. Versatility, precision and superb value make the Leigh Dovetail Jig better than the rest. Rout through and half-blind dovetails up to 24" wide in boards up to 1 1/2" thick, with infinitely variable spacing of pins and tails — all on one jig. Plus, rout sliding and angled dovetails easily with the D4. And create decorative Isoloc joints, finger joints, and multiple mortise & tenons effortlessly with Leigh attachments and our exceptional user guides! Make routing easier with Leigh. Call toll free now!

Call For Your FREE Leigh Catalog Today! 1-800-663-8932

LEIGH
Joining Tradition With Today

Leigh Industries Ltd., PO Box 357
Port Coquitlam, BC Canada V3C 4K6
Toll free 1-800-663-8932 Tel. 604 464-2700
Fax 604 464-7404 Web www.leighjigs.com

BIG VALUE

For Just A Few Bucks, You Get A Whole Lot Of Bits.



VARIETY

Router Bits



VERSATILITY

Drill Bits



SAFETY

Shop Safety Set



POPULAR SIZES

Forstner Bits

Other sets available.

For just a few bucks, you can get all the bits you need for your next project – and more!

Hickory Woodworking sets provide tremendous value with a whole lot of bits to help you produce a wide variety of project designs. For more information, call **1-800-828-9000** or visit www.oldham-usa.com.



Be a woodworker!

Cam-locking Stop Block a Cinch to Make

THE WINNER:

This simple jig clamps quickly to my table saw's fence and helps with two common operations. It serves as a gauge block when performing long crosscuts using both my fence and miter gauge. The gauge block prevents the work from getting caught between the fence and blade. It also is a great stop block when making stopped cuts, such as when notching out corners of a panel.

The block is 1" thick so it's easy to compensate for its thickness on my saw fence's scale. The dimensions given fit my Jet Xacta fence, but can be adjusted to fit yours. The radii on the cam lever are approximate; sand it until it works smoothly.

Rick Wilson
Houston, Texas

This edge should be $\frac{1}{16}$ " from face of fence with stop in unlocked position

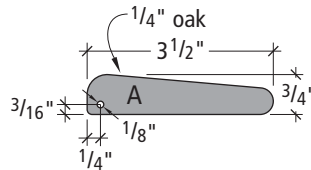

Profile

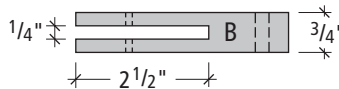

Plan

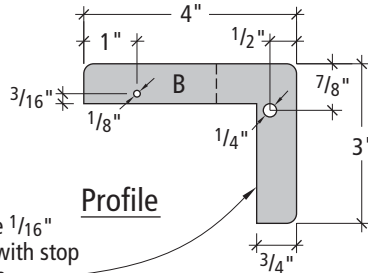

Profile

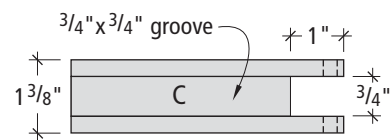
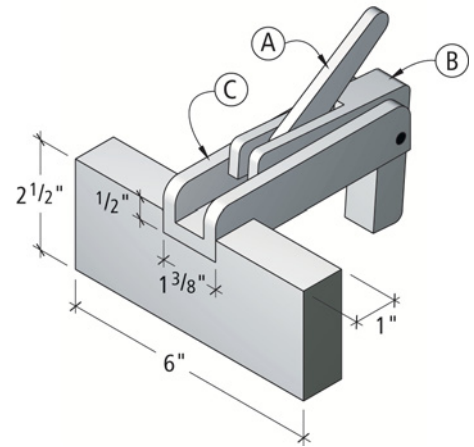

Plan

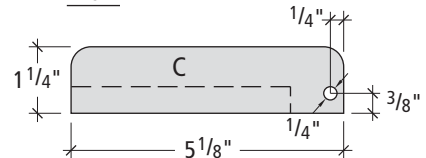

Profile

continued on page 24

Illustration by John Hutchinson; following illustrations by John McCormick

CASH AND PRIZES FOR YOUR TRICKS AND TIPS!

Each issue we publish woodworking tips and tricks from our readers that we think are useful. We want to encourage you to share with your fellow woodworkers, as well as reward the most useful and original concepts. For this issue's winner, Porter-Cable and Oldham have teamed up to offer this great prize. The winner receives the Porter-Cable 7518 $\frac{3}{4}$ -horsepower, five-speed router and a five-piece Deluxe Cabinet Door Set from Oldham. This prize package is valued at more than \$600. The other tricks' authors will each receive a check for \$75.



PORTER-CABLE

NEXT ISSUE'S WINNER...

Our winner in the April issue will receive a fantastic finish-sanding kit from Fein Tools, including the Turbo III vacuum and a MSF 636-1, 6" right-angle sander – \$1,000 worth of tools! This package is, in our opinion, the best finish-sanding setup you can buy. But our winner won't have to. Send us your tip or trick by e-mail (along with a daytime phone number) to david.thiel@fwpubs.com or mail it to:

Tricks of the Trade
Popular Woodworking
4700 E. Galbraith Road
Cincinnati, OH 45236



Fein



**FIRST WE RAISED THE BAR.
THEN WE LOWERED THE PRICE.**



*Due to heavy demand,
quantities are limited.
Check with your distributor
for availability.*

Introducing the innovative JET 10" SuperSaw.

It's the attention to detail that sets this saw apart, so let's cut to the chase. Compared to the competition, the JET 10" SuperSaw features two solid cast-iron wings instead of stamped steel giving it twice the cast-iron work surface of other saws. Its optional sliding table boasts a miter gauge with T-slot and a handy

angle reference guide. It has a brand-new fence with magnified cursor, micro adjustment and 4 T-slots for jigs. And it's heavier than the competition, with a fully enclosed cabinet, larger dust port, and wider stance that makes it far more stable. The SuperSaw is also the only saw on the planet that includes an on/off switch that can

be positioned anywhere along the fence rail, plus thoughtful details like a reset button and power indicator light.

So to review, the JET 10" SuperSaw has better specs, more features, and a warranty that's twice as long. Oh, and did we mention it costs less? Visit your JET distributor for more details.



*For a free 23-minute video
showing everything the SuperSaw can do,
call 1-800-274-6848 or visit jettools.com.*

JET

Powermatic, Performax and JET. A Family of Brands.

TRICKS OF THE TRADE

continued from page 22

Planer Extension Tables

My 12" planer has one of the longest feed tables on the market. However, when planing really long stock, I slip a 4' x 12" piece of medium density fiberboard (MDF) with a board added to the front edge to hook over my in-feed table. This gives added support for those long pieces. Sand the top surface of the MDF and wax it for easy feeding of stock.

Robert Smith
Dallastown, Pennsylvania

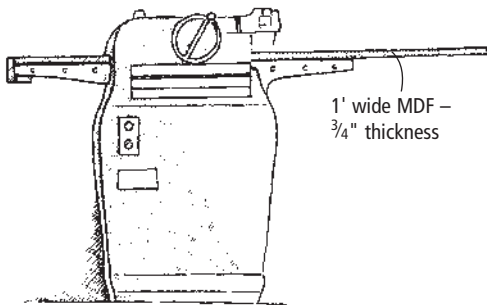

Fold-flat Inexpensive Shop Horses

One problem I always have when doing wood-working projects is table space. While I have a couple sets of sawhorses that I use to set up temporary tables, the more sawhorses I have, the more I have to store when I'm not using them. So I came up with a unit that stores easily and is versatile.

These are easy to build to any size required and cost a lot less than the price of metal folding sawhorses. The legs are just 2x4s with an angled dado (24°), half the depth of the 2x4, cut in each leg. The legs are cut at a 57° angle at the top and bottom. The long dimension is 45½", making the horse 36" tall. I add 1x4s top and bottom to keep the horse stable. Drill a hole

through the center of the dado in each leg and secure the two legs with a ½" x 3½" carriage bolt and a wing nut. To store the horses, simply loosen the wing nuts, pull the dados apart, swivel the legs on the bolt until the 2x4s align, then retighten the wing nut.

Dischmond L. Spurrier
Wellsburg, West Virginia

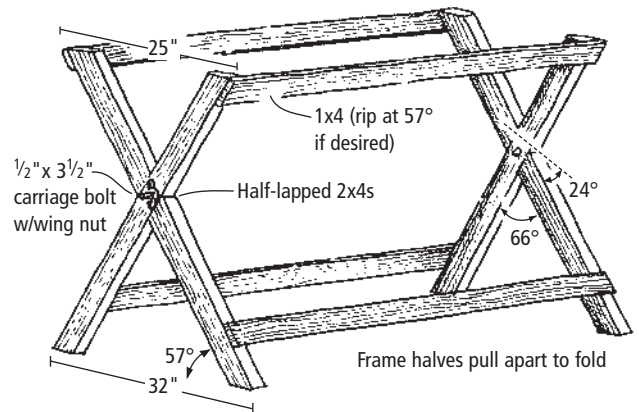

continued on page 26

At the advent of neo-classicism, the Louis style incorporated many Greek elements such as wreaths, scrolls, leaf and flower forms, and interlaced bands.

LOUIS SUITES

We now carry 4 complete suites of Louis-style hardware, each offering at least 10 items to choose from, including various size handles, knobs, pulls and escutcheons. All are solid brass, some with an aged bronze finish, others with an antique finish. Affordably priced from \$1.00 to \$5.15. View them online or contact us for a free catalog. **1-800-683-8170**

Shop online:
www.leevalley.com

Lee Valley Lee Valley Tools Ltd.
814 Proctor Ave., Ogdensburg, New York 13669



TWO GREAT BRANDS. ONE GREAT DEAL.



Buy the best-selling JET XACTA™ Saw and get a **BOSCH** Router FREE.

Priced at just \$1,699, the 10" XACTA™ Saw, with a powerful 3HP motor, and packaged with the XACTA™ Lift with a deluxe router fence, is a great deal. And now it's even better! Because if you buy this XACTA™ Saw package now, we'll upgrade your purchase to include our new Premier MicroAdjust Fence...that's a \$100 value!

But that's not all. You'll also get a Bosch Router...**absolutely free**. Valued at \$239, the Bosch 2 1/4 HP electronic, variable-speed router is the top choice. For more details, visit your local dealer, www.jettools.com, www.bosch.com or call 1-800-274-6848.

J E T
WMH TOOL GROUP

continued from page 24

Lathe Dust Collection for Sanding

I really enjoy woodturning, but not the dust that's created when sanding the project. I made a simple jig to hold the plastic wand from my shop vacuum and it removes 95 percent of the sawdust. I turned a dowel to the size of my tool rest post and attached it to a plywood square about 3" x 3" with a circle cut out that accepts the shop vacuum's

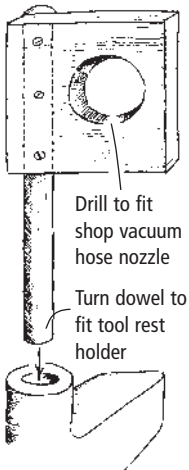

shop vacuum's nozzle. When I've completed my turning, I remove the tool rest and insert the dust collector jig. It's a simple move to position the jig inside or outside of a bowl when sanding or alongside a spindle.

Jim Vasi
Williamsville,
New York

Homemade Air Scrubber Moves 1300 cfm

I built an inexpensive, high-volume shop air cleaner that I think other woodworkers should see. It's quiet and costs much less than commercial box filter units. The materials were mostly scrap, with the exception of an attic fan from Home Depot (\$40) and eight furnace filters (\$15). It moves 1300 cfm through four sets of filters (a 10-micron filter and a .3-micron secondary filter). I used 20" x 25" furnace filters. The box pulls air into the top of the unit and pushes the air through the sides, passing through the paired filters. The filters fit into grooves cut into "L"-shaped wooden corners. Bungee cords hook into the eye bolts and hold everything together. I used a piece of 1/2" x 1/2" metal screening to cover the intake port.

The cleaner can sit on the floor, is portable, or it can be hung up near the ceiling if preferred.

Todd Houser
Okemos, Michigan

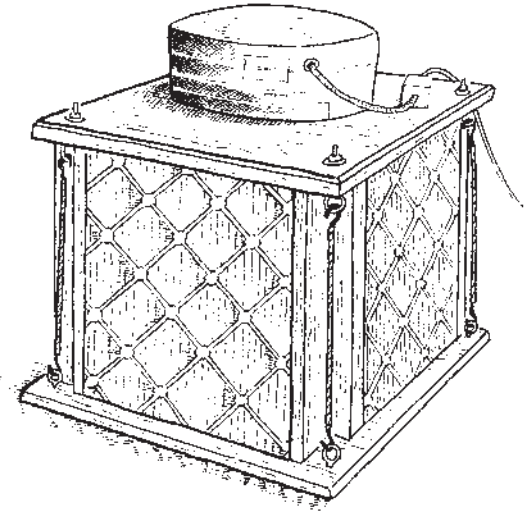

continued on page 28

The Best Place to Buy Over 60 Panasonic Tools Online at the lowest prices guaranteed*

Shop at www.amazon.com/panasonic



*We will match our competitors price plus beat it by 10% of the difference. Find out more at www.amazon.com/price-match.

Call for your FREE Tool Crib catalog
1-800-635-5140

TOOLS & HARDWARE
amazon.com

NEW! The Leigh FMT Mortise and Tenon Jig



Finally a jig designed to create mortise and tenons in one quick easy setup!

FMT features:

- Unique patented guide system
- Joints of any size from 1/2" x 5" down to a tiny 1/16" x 3/32"
- Use on matches or stock up to 3" x 5 1/2" (mortise) and 2 3/4" x 5 1/2" (tenon)
- Easy fingertip adjustment of joint tightness
- Make angled and compound angled joints
- Rout perfectly aligned double, triple and quadruple joints
- Use virtually any plunge router
- Uses 1/2" shank cutters
- Cam-action speed-clamps
- Integral dust port for vacuum

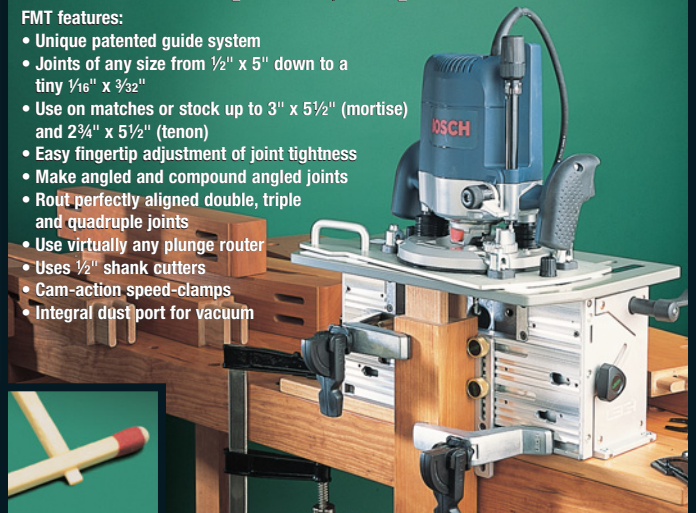

Call For Your Free Leigh FMT Brochure Today! 1-800-663-8932
Leigh Industries Ltd., PO Box 357, Port Coquitlam, BC, Canada V3C 4K6
Tel. 604 464-2700 Fax 604 464-7404 Web www.leighjigs.com

LEIGH
Joining Tradition With Today

More power. More capacity.

Turbo III Dust Extractor



Introducing the **NEW FEIN Turbo III** Portable Vac.

The new 9-77-25 makes dust-free sanding and wet/dry cleanup easy and practical. The perfect size for big jobs, the Turbo III features 14.5 gallon capacity, an automatic on-off switch and a three-second hose-cleaning delay. The powerful two-stage motor offers bypass cooling to prevent electrical damage and prolong the life of the motor. And with 10% more suction power than the Turbo II, it can run two 6" or one 8" Random Orbit Sander.

For more information and the name of a local dealer, visit us at www.feinus.com or call 1-800 441-9878.

Finishing is just the beginning.

Fein Power Tools, Inc. 1030 Alcon Street Pittsburgh, PA 15220

CIRCLE NO. 118 ON FREE INFORMATION CARD.



Fein

WHITECHAPEL LTD

Fine Hardware for home, cabinet and furniture



1-307-739-9478

Free color catalog available www.whitechapel-ltd.com

CIRCLE NO. 160 ON FREE INFORMATION CARD.

New From ...

Lie-Nielsen TOOLWORKS INC.

Makers of Heirloom Quality Tools™



www.lie-nielsen.com

P. O. Box 9, Warren, Maine 04864

1-800-327-2520

CIRCLE NO. 133 ON FREE INFORMATION CARD.

NEW

UNILIFT

- Quad Post Support
- Dual Lift Screws
- 1/32 or 1/16 Pitch
- Fits Most Routers

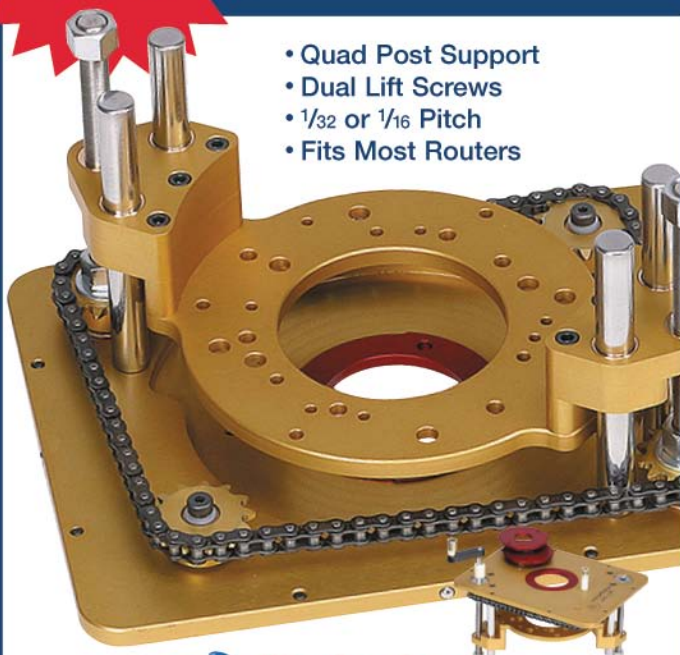

 **Woodpeckers**

1.800.752.0725

www.woodpeck.com

CIRCLE NO. 168 ON FREE INFORMATION CARD.

TRICKS OF THE TRADE

continued from page 26

Quick-release Table Saw Guard

Having become tired of bolting and unbolting the blade guard of my table saw, I came up with an idea that allows for quick removal and installation with no tools.

All I did was place a strong compression spring on the outside of the two mounting flat washers. This compresses the washers together and they squeeze the mounting flange of the guard, keeping it in place. I sandwiched the convex side of the flat washer together. This provides a slight gap to allow the blade guard to pry the washers apart when installing the guard. To make sure it stays together, I replaced the original nuts with plastic insert lock-nuts. For the inside mount I had to use a slightly longer bolt in order to have enough thread exposure past the mounting flange. This allowed me to install the plastic insert lock-nut.

Tighten the nut and bolt together to achieve a tight grip on the guard. To remove the guard, just remove the throat plate and lift out the blade guard. To install the guard again, remove the insert, use the guard to wedge open the washers and set it in place.

F. Chrysanthos
Etna, California

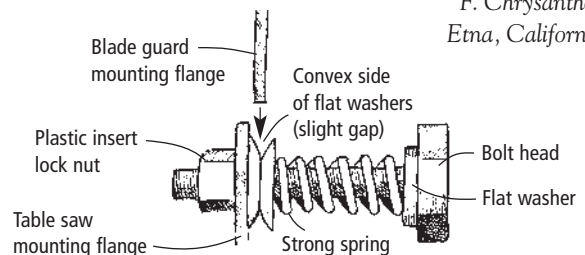

A Third Hand at the Workbench

Add a helping hand to your bench. This simple jig wedges against your workbench's leg to support big or long work pieces, such as a door. Clamp one end of your work in your vise and rest the bottom edge of the other end of your work on this jig.

These quick supports are easy to adjust and can be made from a good 2x4, a small strip of wood and a few screws. The size and angle can be adjusted to fit your needs.

If your project is shorter than your bench (falling between the two supports), you can add a 2x4 running from leg to leg as a cross-beam support. For even extra support you can screw the cross beam to the helping hands. **PW**

Dan Lindsey
Girard, Pennsylvania

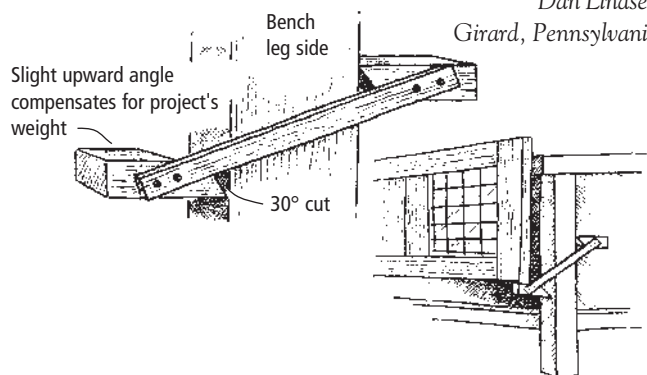



7pc & 16 pc Forstner Bit Sets



1250 7 pc set Reg \$24.95
\$16.95



1/4" to 2-1/8" by 1/8" increments
1252 16 pc set
Regular \$59.95 **\$39.95**

25 pc Brad Point Drill Bit Set



1/16" to 1/2" 1302 - Retail \$29.95
SALE \$19.95

7 pc Tapered Drill Set



1316 For screw sizes
Retail \$29.95 5, 6, 7, 8, 9, 10 & 12
SALE \$19.95

Mirka Sandpaper



9" x 11" Carat Brand White Finishing Sheets 50 pack
Buy 4 or more packages
Save extra \$1.00 OFF per pkg
MIX-N-MATCH Grits
Made in Finland

Regular \$21.95 pkg
\$17.95 pkg
Your Choice Grit

Mirka Bull Dog Gold



D-Weight - Hook-n-Loop
5" X 5 hole or 5" X 8 hole - 50 box



5" x 5 hole
1009 - 80g
0981 - 100g
0982 - 120g
0983 - 150g
0984 - 180g
0985 - 220g
0986 - 320g
0987 - 400g
0988 - Asst

Buy 4 or more boxes
Save extra \$1.00 OFF per box.
MIX-N-MATCH Grits

Regular \$19.95 box
\$14.95 box
Your Choice Grit
Made in Finland

5" x 8 hole
0989 - 80g
0990 - 100g
1020 - 120g
1021 - 150g
1022 - 180g
1023 - 220g
1024 - 320g
1025 - 400g
1026 - Asst

Clamp-n-Tool Guides

4900 CT-24" \$25.95
4901 CT-36" \$28.95
4902 CT-50" \$33.95

Back-to-Back Clamps

4903 BB-18" \$34.95
4904 BB-36" \$41.95
4905 BB-50" \$51.95

Works Great as a Fast Attaching Fence for Band Saw or Drill Press Tables



30 pc Shop Carbide Tipped Router Bit Sets



Only \$3.33 each!



4754 - 1/2" shk Your Choice **\$99.95**
4755 - 1/4" shk Reg \$159.95

24 pc Carbide Tipped Router Bit Sets

4752 - 1/2" shank
4753 - 1/4" shank
Reg \$129.95
Your Choice **\$79.95**
Only \$3.33 each!

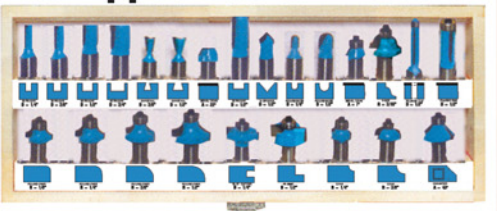

15 pc Carbide Tipped Router Bit Sets

4750 - 1/2" shank
4751 - 1/4" shank
Reg \$67.95
Your Choice **\$44.95**

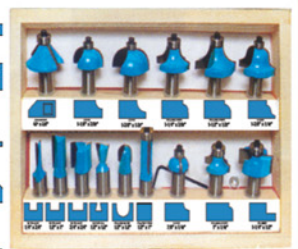
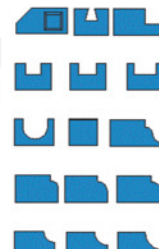

"That's only \$3.00 per bit"

Order Now 1-800-892-4866

Visit The WoodShop On-Line Catalog Store to find a giant selection of woodworking tools & accessories, PLUS fantastic deals on Overstock & Discontinued Items

www.thewoodworkerschoice.com
www.1-800-twc-4tools.com

The Woodworker's Choice

2 The Professional Drive
West Jefferson, NC 28694

Ad Special - \$3.95 shipping within continental USA

Individual & Package Deal Tru-Grip Clamps

Individual Pro ft'r
Accessories
4911 4' PRO ft'r \$66.95
4913 Router Base \$26.95
4914 Saw Base \$28.95

Tru-Grip Pro ft'r Package

Includes:
(1) 4911
(1) 4913
(1) 4914
\$119.95



4900A Woodworker's Super Package
Includes: (2) 4904, (1) 4902
\$109.95

Because Woodworkers Like To Buy From Woodworkers



Australian Router Trying to Turn the Router World Upside Down

Beyond being a capable and comfortable router for both hand and table use, the Triton TRA001 offers convenience and safety features we consider well worth having. Then to sweeten the pot the manufacturer tossed in some well-thought-out extras, increasing the value.

This is the only router on the market today that allows you to “dial” in the full plunge depth, extending the collet past the base plate so you can loosen it from below the base rather than between the posts. Similar features are available on router lift mechanisms, but at a high price, making this plunger an attractive option for router-table work.

When the router is in its fully plunged position, the spindle lock is automatically engaged (allowing one-wrench bit changes). And for added safety a lock-out door covers the power switch, making it impossible to accidentally start the router.

The Triton router also offers three different plunging mechanisms: a free-plunge setting, a standard plunge lock lever to lock the depth position in place, and a rack-and-pinion “winder” adjustment operated through the right handle of the router that allows a controlled plunge, rather than a free plunge. For detail work, a micro-adjustment mechanism works in the rack-and-pinion mode, allowing adjustments of approximately $\frac{1}{32}$ " per half-turn of the knob.

When used in a router table, there's an easily removable plunge spring (back out a screw, pop off the cap and remove the spring) for no-resistance bit-height adjustments.

Other features include a versatile turret depth-stop system, a quality metal fence system that can be used as an edge guide with a 6" reach or as a circle-cutting jig. One nice touch with the fence is it requires no tools to attach it to the router. Plus you get a $\frac{1}{2}$ " carbide straight router bit. This tool is loaded!

Then we plugged it in and made some chips. We were pleased with the power and performance of the router. It proved a smooth operating machine, and the plunge adjustments are slick and easy to operate once you get comfortable with the tool.

Dust collection also has been included, with two clear shields and a base-integral dust collection hook-up ($1\frac{1}{2}$ " dia.). We ran a $\frac{1}{2}$ " x $\frac{1}{2}$ " groove in plywood with and without dust collection. Efficiency was about 90 percent with the hook-up, which is more than adequate by our standards.

Triton is a new tool brand to us, and if we



Photo by Al Parrish

SPECIFICATIONS

Triton TRA001 Plunge Router

Street price: \$329

Motor: $3\frac{1}{4}$ hp, 15 amp, 8K to 20K rpm
with soft start, elec. feedback

Collets: $\frac{1}{4}$ " and $\frac{1}{2}$ "

Plunge depth: $2\frac{21}{32}$ "

Weight: 13.5 pounds

Performance: ●●●●○

Price range: \$\$\$\$

Triton Workshop Systems: 888-874-8661,
or tritonwoodworking.com

had more experience with the brand's long-term capabilities, this tool would likely earn a five for performance. While priced at the higher end of this router category, the special features, plus the bit and quality edge guide nicely offset the price, making this router not only an innovative tool, but a good value as well.

For more information, circle #155 on Free Information Card.

HOW WE RATE TOOLS

We test new tools and products with an honest, real-world workout. We start from the box, assemble the tool if necessary, and read the manuals to see how clear they are. Then we put the tools to use in our shop, building projects. Then our staff shares the result with you.

We rate performance on a one-to-five scale, with “five” indicating that we consider it to be the leader in its category. For price range, five dollar signs means the tool is priced high in the category, with one dollar sign indicating a low price. Three dollar signs is an average price.

If all your questions aren't answered here, e-mail me at david.thiel@fwpubs.com or call me at 513-531-2690, ext. 1255. You also can visit our web site at popularwoodworking.com to read previous tool reviews and sign up for our free e-mail newsletter (focusing on tools) that's sent out every other week.

—David Thiel, senior editor

Craftsman 6 1/8" Jointer Offers Affordable, Powerful Performance

The first thing that intrigued us with this machine was finding an enclosed-stand jointer in a small flat box. Craftsman did a clever job of shipping a sturdy, enclosed-stand jointer in a compact space.

After assembly we checked the tables for flatness (no problems) as well as the fence (a .004" bow at the center lengthwise, but not enough to cause problems).

Features include a decent plastic dust-collector port (4" connection) and as hokey as it may sound, a handy metal shelf for the two good-quality push paddles.

During testing, we found the fence to be square to the table right out of the box. But if a 90° or 45° angle isn't your goal, it's less convenient because there are no markings or set-pin locations. One benefit of the fence is the ability to adjust for both internal and external 45° angles.

To test performance, we started with a simple facing operation, and we easily accomplished a series of 1/32" passes on a rough 6" piece of figured cherry with no tearout. To push the envelope, we reset the depth to the maximum 1/8" and ran the same board again. There was a distinct change in the motor sound, but the jointer handled the cut with



SPECIFICATIONS

Craftsman 21706 Jointer

Street price: \$380

Motor: 1 hp induction, 5,000 rpm

Fence: 4 1/2" x 29 1/4", tilts in and out to 45°

Table: 7 1/2" x 46 1/8"

Weight: 230 pounds

Performance: ●●●●○

Price range: \$\$\$

Craftsman: 800-377-7414 or craftsman.com

little hesitation and still made a nice cut.

Changing the high-speed-steel knives is reasonably easy using the two height-adjustment screws (similar to jackscrews).

Overall, similarly outfitted 1 hp units range in price from \$325 to \$499. At \$380, this Craftsman provides a good-quality machine at a better-than-average price.

For more information, circle #150 on Free Information Card.

TOOL SCOOP

Leigh Mortise-and-tenon Jig an Engineering Marvel



When it comes to dedicated aftermarket jigs, we usually err on the "less is more" side, feeling the money can be better applied elsewhere. We're not necessarily changing our tune in considering the Leigh Frame Mortise and Tenon Jig (FMT), but it's a heck of a jig. Priced at \$800, we were skeptical when introduced to this new tool from the well-respected dovetail jig manufacturer (leighjigs.com). But after a few hours of viewing and reviewing the engineering and quality that went into the manufacturing of the jig, it looks like a good investment. This isn't a jig for everyone, but if you're going to be making lots of mortise-and-tenon joints, the FMT offers a slick, intelligent approach with guaranteed accuracy and success. Even the stout hold-down clamps on this tool are worthy of high praise.

The jig's precision is impressive. You can cut tight mortises and tenons in stock up to 3" x 5", or as small as a matchstick. Both the mortise and tenon cuts are guided by a single snap-in guide. Tapered guide pins in the router base follow the guide and offer .001" accuracy. The sub-base itself allows the router to be removed for other uses, then reinstalled to the same accurate setup in a couple of minutes. Initial setup on the base can be fussy, but once set, it can be forgotten. Other features include an easily adjustable clamping plate with a 30° range, a tenon side-stop fence that also offers 45° adjustment to left or right, a retractable sighting system to quickly locate mortise and tenon locations in the material, and table-limiting stops for easy single-joint use or for repeatable multiple-joint use. This is a slick system that we'll be using to build a project in the April issue.

Shop Dolly a Versatile Snap-together Bargain

When we saw the ad for an \$8.95 snap-together dolly rated at 220 pounds, we had to take a look. It's worth every penny!

I'm not saying you should park your router table on this guy and roll it around your shop, but for need-it-now mobility, it does quite well.

Each 3 1/4" x 14 1/4" plastic section has four staggered swiveling plastic casters, and the sections snap together (using dovetail joinery) to form a variety of shapes, or to add to another dolly set. The package includes four of the sections and measures 20 1/2" x 14 1/4" when assembled as a rectangle.

The snap-together joinery isn't perfect and the casters can be a little balky (carpeting is a bit of a hurdle), but for less than \$10 there'll be one in my trunk! **PW**



SPECIFICATIONS

Portable Dolly (99W39.77)

Street price: \$8.95

Performance: ●●●○○

Price range: \$

Lee Valley: 800-871-8158 or leevalley.com

For more information, circle #130 on Free Information Card.

Metabo Jigsaw a Tough Performer

We ran this upstart tool through its paces to see how it stood up to the rigors of our shop.

We welcomed the STE 105 Plus jigsaw from Metabo into the *Popular Woodworking* shop three years ago. None of us thought it could be as good as a Bosch jigsaw. Oh, well. However, at the end of that year we named it one of the Best New Tools of the year, and it's stayed in our tool cabinet thanks to its power, durability and easy blade-changing mechanism.

A quick recap on the tool: Though available in both a barrel grip (as shown and tested) and a top-handle grip, we prefer the barrel grip for control and comfort. At 6 amps, the motor is the most powerful available in the category (tied, at least on paper, with Porter-Cable's 9543). The variable-speed control allows a very comfortable 1,000 to 3,000 rpm range. The five-position orbital-motion selector allows smooth or aggressive cutting with a nice spread of in-between choices. And the 1" blade stroke is the largest offered and works in wood up to 4 $\frac{1}{8}$ " thick.

After three years in our shop, there are still lots of things we like about the Metabo. Its raw power makes quick work of almost any cutting task, while the grooved-roller blade guide does an excellent job of keeping the blade tracking straight throughout the cut. The tool continues to function smoothly. The controls are easy to use, with a very simple tool-free blade-changing system that's still at the top of the category. Simply pull the spring-loaded lever away from the blade mount and pull the blade free. No sweat.

While the jigsaw gets used a lot without hooking up the dust collection, when so outfitted the dust collection is very good, with a front shield to capture the dust and a nicely designed directional port to pull the dust back through the base.

Speaking of bases, the angle adjustment is accurately accomplished with a simple hex wrench. With seven pre-set and notched angle locations, (15°, 30° and 45° to either side of the blade plus 90°) setting and forgetting is easy. And if you need a different setting, bypass the notches and lock it in.

When we acquired the STE 105, it cost about \$210, which was somewhat higher than its competitors. This tool is now going for about \$180, which still is slightly higher than the others, but makes it a much easier decision to spend the extra money.

We have managed to damage our STE 105. It got dropped (go figure) and it took the hit on the foot plate. We were pretty concerned, because the plate is a magnesium casting, but Metabo also included a steel support plate under the foot. Happily, even though the casting snapped, we were able to bend the steel plate back and reattach the casting. We still use the jigsaw every day and no one notices the break.

If we had to make any changes, a simple one would be an easier storage location for the hex wrench for beveling the foot. We're pretty sure ours was attached to the cord (the

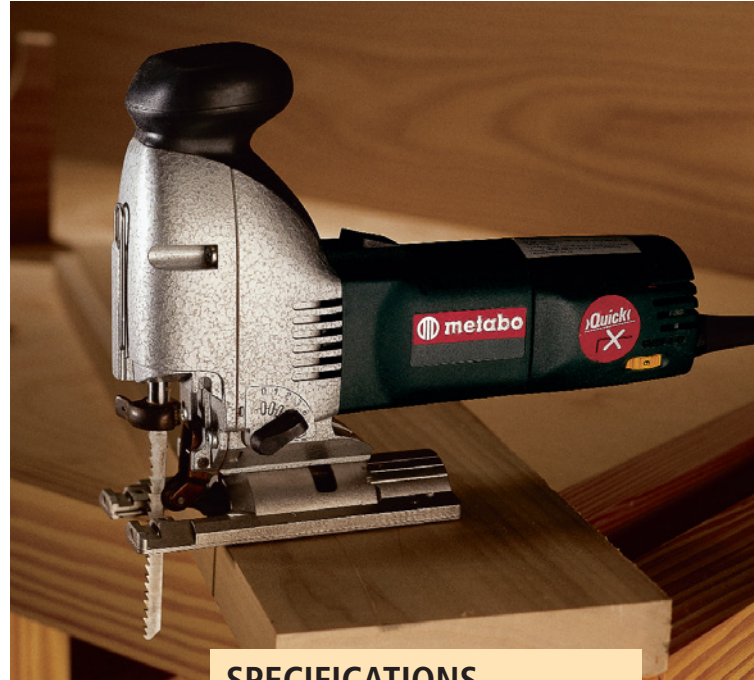

SPECIFICATIONS

Metabo STE 105 Plus Jigsaw

Street price: \$180

Motor: 6 amp

Speed range: 1,000 - 3,000 rpm

Stroke length: 1"

Blades accepted: "T" or universal style

Orbital settings: 5

Max. material thickness: 4 $\frac{1}{8}$ "

Weight: 4.9 pounds

Nice features: Smooth operating, powerful tool that has very user-friendly options. This is a durable and reliable jigsaw.

Recommended modifications: Make the hex wrench easier to find.

For more information: Contact Metabo at 800-638-2261, or metabousa.com.

ABOUT OUR ENDURANCE TESTS Every tool featured in our Endurance Test column has survived at least two years of heavy use in our shop here at *Popular Woodworking*.

excellent 15' rubber cord), but honestly we don't know where that went. If there were a way to keep it on the body of the saw, that would be preferable. Other than that, if you're working in a shop with other woodworkers, buy two, because this impressive tool will be missing when you go to use it. **PW**

— David Thiel, senior editor

4-WAY MONEY-MAKER!



- Molds
- Planes
- Sands
- Saws

FREE 30-DAY TRIAL!

Now, turn a \$5 rough board into \$75 worth of high-dollar molding in less than one minute! Make over 350 standard patterns, picture frame stock, any custom design. Quickly converts from **Planer/Molder** to **Drum Sander** or **Gang Rip Saw!** Choose from 12", 18" and 25" Models.

Variable Feed Makes The Difference!

Just a twist of the dial adjusts the Woodmaster from 70 to over 1,000 cuts per inch. Produces a glass-smooth finish on tricky grain patterns no other planer can handle. **Five Year Warranty. Prouder Than Ever To Be Made In America!**

FREE FACT KIT!

1-800-821-6651 ext. TP19

Woodmaster Tools, Inc. 1431 N. Topping Ave. Kansas City, MO 64120

Check Out

WWW.PENMAKINGSUPPLIES.COM/PW

STEVE WALL LUMBER CO.

Quality Hardwoods and Woodworking machinery For The Craftsman and Educational Institutions

Ash	4/4	Select	2.40	\$ 85.00
Basswood	4/4	Select	1.95	\$ 72.00
Birch	4/4	Select	2.75	\$ 89.00
Butternut	4/4	1C	2.30	\$ 77.00
Cherry	4/4	Select	4.90	\$110.00
Hickory - Pecan	4/4	Select	2.85	\$ 89.00
Mahogany (Genuine) ..	4/4	Select	3.90	\$100.00
Maple (Hard)	4/4	Select	3.15	\$ 96.00
Maple (Soft)	4/4	Select	2.30	\$ 79.00
Poplar	4/4	Select	1.75	\$ 72.00
Red Oak	4/4	Select	2.50	\$ 88.00
Walnut	4/4	Select	4.00	\$100.00
White Oak	4/4	Select	2.50	\$ 88.00
Cedar (Aromatic Red) .	4/4	1C+Btr.	1.80	\$ 72.00
Cypress	4/4	Select	2.40	\$ 80.00
White Pine	4/4	F.G.	1.20	\$ 62.00
Yellow Pine	4/4	Clear	2.00	\$ 74.00

UPS Specials

SEE OUR CATALOG ON THE WEB!

Above prices are for 100' quantities of kilndried rough lumber sold by the Bd. Ft. FOB Mayodan, NC. Call for quantity discounts. Other sizes and grades available. Above prices are 20 bd. ft. bundles of clear kilndried lumber 3'-10" wide • 3'-7" long (Random widths & lengths) Surfaced 2 sides or rough. Delivered UPS prepaid in the Continental U.S.

NOW AVAILABLE
Custom Made Raised Panel Cabinet Doors
 4/4 Log Run Walnut | Also Available
 100 bd. ft. \$160 | Exotic Lumber

STEVE H. WALL LUMBER CO.
 BOX 287
 MAYODAN, N.C. 27027
 336-427-0637
 1-800-633-4062
 FAX 336-427-7588
 Email: wood@walllumber.com
 Website: www.walllumber.com

Send \$1.00 For Lumber Catalog
 Prices Subject to Change Without Notice

CIRCLE NO. 159 ON FREE INFORMATION CARD.

Precision & Safety Should Be Standard Equipment On Every Tablesaw...

The Osborne EB-3 Miter Guide's innovative design ensures it is more rigid and stable than any other miter guide available. Over 40" of support. Accurate to within 1/30th of a degree.



...Now They Can Be



The Merlin Splitter features tool-free removal and reinstallation, anti-kickback pawls and a thinner design. Click-In, Click-Out convenience. See it at your local Woodcraft store or call us for a local dealer. \$109.95 (M.S.R.P.) Sears Model \$119.95 (M.S.R.P.)

Fits Most Saws



1 800 357 4118

The *Ultimate* Woodworking System

www.excalibur-tools.com

CIRCLE NO. 117 ON FREE INFORMATION CARD.

Rockler.com
 WOODWORKING SUPERSTORE

WIN A DELTA UNISAW

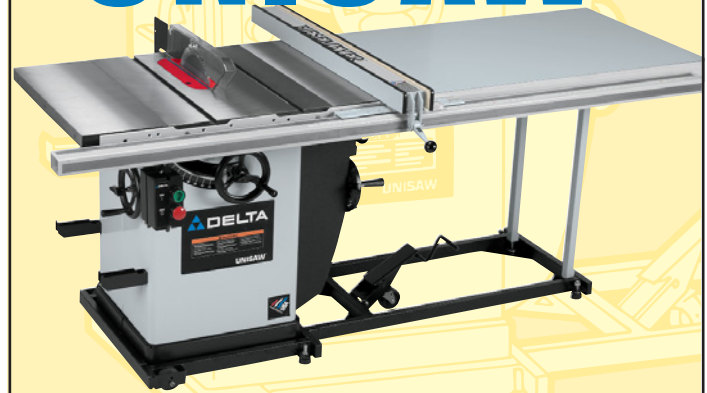

Register online at...
www.rockler.com/delta

No purchase necessary. See official rules at www.rockler.com/delta. Void where prohibited by law. Entries must be received by April 30, 2003.

CIRCLE NO. 147 ON FREE INFORMATION CARD.

FREE!

WOODWORKING CATALOG

Check out our complete **EXCLUSIVE** line of jigs and shop tables for your band saw, drill press and router.

PLUS thousands of other great products!

Go to rockler.com/go/V3326 or call **1-800-403-9736** and order your **FREE** catalog today!



ByPhone 1-800-403-9736 ByFoot 1-877-ROCKLER ByNet www.rockler.com

CIRCLE NO. 148 ON FREE INFORMATION CARD.



Prepaid Freight • Surfaced • Bundled
Shrink Wrapped • Guaranteed

- All lumber is Select and better grade, 4" and wider, averaging 6"-7" in width, lengths are 6'-8'. All stock meets or exceeds National Hardwood Lumber Assoc. grade rules.
- All domestic lumber is Northern Appalachian grown, exhibiting characteristics of fine grain, texture and uniform color.

Visa/Mastercard/Discover accepted.

Niagara Lumber & Wood Products, Inc.
47 Elm Street • East Aurora, NY 14052
Call Toll-Free 1-800-274-0397
www.niagaralumber.com

CIRCLE NO. 139 ON FREE INFORMATION CARD.



GENERAL MACHINERY

The only High Quality, Heavy Duty Line of Woodworking Equipment Tablesaws, Jointers, Mortisers, Lathes, Drill Presses and accessories including Modulus® Scoring Saw Attachment

EXCEPTIONAL PRICING SERVICE & VALUE
Made In Canada

www.woodworktools.com
ASHMAN TECHNICAL LTD.
351 Nash Rd, N. Hamilton, Ontario, CANADA L8H 7P4
Phone 905-560-2400 • FAX: 905-560-2404
1-800-668-5721

CIRCLE NO. 103 ON FREE INFORMATION CARD.



WE WILL MAKE PRODUCTION RUNS OF YOUR PART

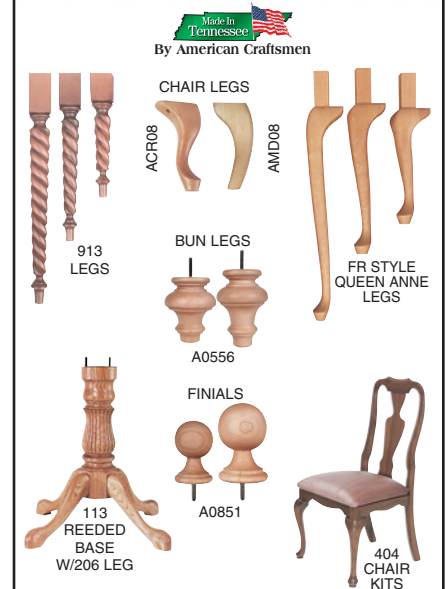

P.O. Box 728, Dept. PW17
Morristown, TN 37815-0728
Phone 423-587-2942 • Fax 423-586-2188
www.adamswoodproducts.com **FREE COLOR CATALOG**

CIRCLE NO. 100 ON FREE INFORMATION CARD.

Square Drive Screws from the Source

- Square Drive Stops Driver Bit Slippage!
- Hardened Steel for Extra Strength
- Deep Thread for Exceptional Holding Power
- Available in Stainless Steel, Solid Brass, Plated Steel, Corrosion Resistant and More!
- Sizes from #4 x 3/8 to #14 x 6

Write for **FREE** Catalog!

McFEELY'S SQUARE DRIVE SCREWS

PO Box 11169 • Dept PWDA • Lynchburg • VA • 24506
Toll Free 1-800-443-7937 or at www.mcfelys.com

CIRCLE NO. 135 ON FREE INFORMATION CARD.

ROUTER & TABLE SAW SYSTEMS

- **Combination Router & Table Saw Fences**
Micro Adjustable, Accurate to 1/1000 of an inch
- **Router Tables, Table Saw Extension and Floating Infeed/Outfeed Tables**
Available in Solid Phenolic or Melamine
- **Complete Table Saw Upgrade Systems**
Available for virtually all Cabinet & Contractor Saws
- **True Zero Clearance Miter/Cutoff Sled**
Micro-Adjustable, Positive Detents Every 1/2 Degree
- **Table Mounted Router Lift System**
Raise & Lower a Router with 1/1000 of an inch precision
- **And Much More...**

FREE CATALOG!

CALL TODAY!
1-800-619-1288
www.jointech.com

JOINTECH
ULTRA-PRECISION WOODWORKING SYSTEMS

Jointech, Inc. is an official dealer for products made by: **GENERAL INTERNATIONAL**

CIRCLE NO. 128 ON FREE INFORMATION CARD.

MLCS Pro Cabinetmaker Router Bit Set

Make raised panel doors and much more!

This professional quality set contains six carbide tipped bits needed for cabinet making, raised panel doors, table tops and drawer assembly. These 1/2" shank bits were carefully chosen for their ability to create fine furniture or custom cabinetry for a kitchen. Designed for up to 3/4" wood thickness.

 1. The **Ogee Raised Panel bit** (in the Standard Set) puts a classic ogee edge on the free floating central panel in your door. 2-3/4" large diameter.

 2. The **Ogee Raised Panel with Undercutter** (in the Undercutter Set) produces flush panels, reduces the exposed upper panel profile, or adds a radius to the back of the panel. 3-1/8" large diameter.

 3. Our **Matched Rail and Stile set** creates precisely mated rails and stiles that form an extremely durable, classic frame for your door. 1-5/8" large diameter.

 4. When the central panel needs to be wider than your stock, use the **Glue Joint bit** to mill two or more pieces of stock (up

to 1-1/4") with reverse cut edge joints to reach the required width. After gluing, your panel is ready to be raised. 1-3/4" large diameter.

 5. The **Drawer Lock bit** creates a strong, long lasting joint that fits precisely because one bit makes the cut in the drawer front and the side of the drawer, so both pieces fit perfectly. 1-3/4" large diameter.

 6. The **Round Over & Ogee Door Lip bit** finishes your door edge professionally in one pass. All bits are intended for use in a router table only.

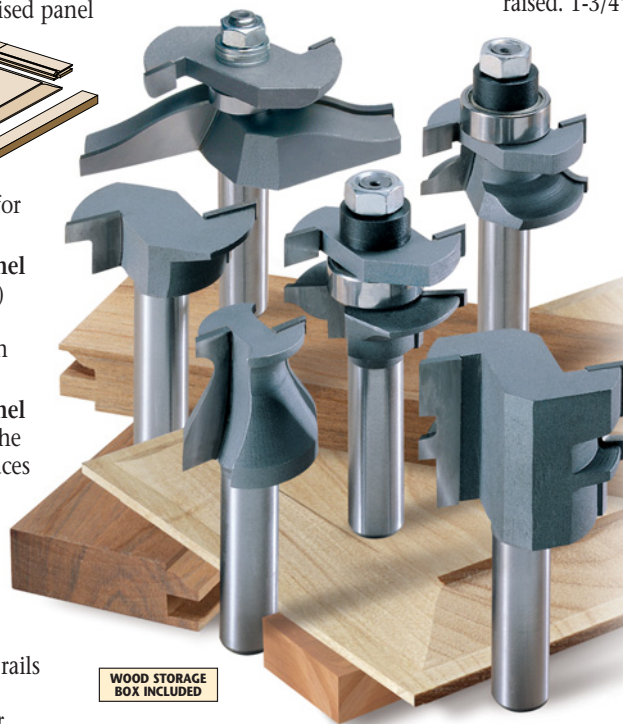

WOOD STORAGE BOX INCLUDED

MLCS
ROUTER BITS AND PROFESSIONAL WOODWORKING PRODUCTS

Cabinetmaker Undercutter Set
\$135⁹⁵
ITEM #1453

Cabinetmaker Standard Set
\$114⁹⁵
ITEM #1452

2 Piece Raised Panel Door Sets!

These carbide tipped sets include cove raised panel router bit with ball bearing and ogee combo rail and stile bit.



1/4" Shank 2" LD Raised Panel Set
Item #1301 **\$69.95**
1/2" Shank 3-1/2" LD Raised Panel Set
Item #1302 **\$79.95**

30 Piece Router Bit Set

30 carbide tipped bits:

- 3 Cove (1/4", 3/8", 1/2")
- 2 Flush Trim (3/8", 1/2")
- 6 Round Over (1/8", 3/16", 1/4", 5/16", 3/8", 1/2")
- 5 Straight (1/4", 5/16", 3/8", 1/2", 3/4")
- 1 Chamfer (45°)
- 1 Slot Cutter (1/4")
- 1 Rabbeting (3/8")
- 1 V-Groove (1/2")
- 1 Bevel (25°)
- 1 Panel Pilot (3/8")
- 2 Roman Ogee (5/32", 1/4")
- 3 Round Nose (1/4", 3/8", 1/2")
- 3 Dovetail (14°-1/2", 5/8" & 9°-3/8")
- 1 Allen Wrench and 1 bearing to convert Round Over into a Beading bit.



\$99⁹⁵
1/4" Shank • #1444
1/2" Shank • #1445

WOOD STORAGE BOX INCLUDED

Router Collet Extension

Give your 1/2" shank router bits an additional 2-1/4" when you extend your router bit through the router table top with our router collet extension. Eliminate the dangerous temptation of withdrawing the shank from the collet in order to raise the bit. The router collet extension makes it possible to use all diameter of bits safely. Instructions included.

\$24⁹⁵
ITEM #1456



66 Piece Router Bit Set

An amazing price for 66 carbide tipped bits!



Includes the 30 Piece Set (left) plus these bits:
Straight (7/16", 5/8", 1"), 1 Bevel (30°),
1 Groove Forming Classical (3/4"), 1 Keyhole (3/8"),
Hinge Mortising (1/2", 5/8", 3/4"), Classical Bit (3/16" r),
3 Core Box (1/4", 3/8", 1/2"), 1 Dish Cutter (1"),
V-Groove (3/8", 5/8"), Cove (1/8", 3/16", 5/16"),
1 Flat Bottom Sign Lettering (5/8" 60°),
1 Double Fillet & Cove (5/16" r), 1 Ogee Filet (1-3/8"),
1 Double Cove & Bead, 2 Edge Beading (1/4", 3/8"),
Dovetail (7.5°-1/4", 14°-3/4), Slot Cutter (3/8")
1 Point Cutting Round Over (1/2"),
1 Flat Bottom Round Over (1/4" r),
1 Multi Bead/Reed Bit (1/8" r),
1 Double Round Over (5/32" r),
1 Cove Sign Lettering (5/8" 60°),
Chamfer (30°, 22.5°, 15°),
4 bearings & allen wrench

\$169⁹⁵
1/4" Shank • #1457
1/2" Shank • #1458

WOOD STORAGE BOX INCLUDED

Router Table Power Switch

Allows safe on/off control of 120V AC routers or tools. Mounts quickly and prevents reaching under the table to turn off your router. Removable lock prevents unauthorized use. Max. 15 amps.

\$24⁹⁵
ITEM #1455



16 Piece Forstner Bit Set

NEW Hex shank set includes these sizes:

- 1/4", 3/8", 1/2", 5/8", 3/4", 7/8", 1", 1-1/8", 1-1/4", 1-3/8", 1-1/2", 1-5/8", 1-3/4", 1-7/8", 2", 2-1/8".

\$43⁹⁵
ITEM #1454

WOOD STORAGE BOX INCLUDED

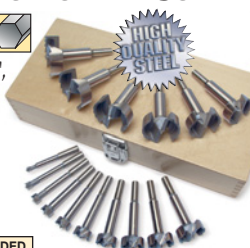

ORDER TOLL FREE: 1-800-533-9298 • WEB STORE: MLCSWOODWORKING.COM • FREE SHIPPING!

SEND CORRESPONDENCE TO: MLCS LTD., P.O. BOX 4053PD, RYDAL PA, 19046

CIRCLE NO. 136 ON FREE INFORMATION CARD.

I-beam Work Island

This bit of plywood engineering can serve as a stout base for almost any kind of workbench or shop table.

I seem to be setting up a lot of workshops lately. So far, our little band of pioneer aviators have set up two shops in Dayton, Ohio, where we are manufacturing the parts of Wright airplanes and assembling them, and a third shop in Kitty Hawk, N.C., which serves as a repair station to take care of the inevitable wing-dings these primitive aircraft suffer when you fly them. And because the heart of any good shop is its workbench,

I seem to be building a lot of benches as well.

With time and materials at a premium, I've developed a simple and economical design for a bench that we use in these shops. It's strong, true, offers loads of storage and with the addition of a few casters, can serve as a movable work island. We find this last feature especially important, because we must constantly reconfigure the shops as the Wright airplanes grow during construction.

A Sandwich of I-beams

The base of the bench is made entirely of $\frac{3}{4}$ " plywood. The plywood parts form three "I-beams," each beam consisting of two caps and a center beam. The shelves and dividers in the bench make up two small I-beams – the shelves become the caps and the dividers are the beams. These are sandwiched together inside a large I-beam that consists of the two workbench ends (the caps) and a

continued on page 38



I make utility benchtops by laminating two layers of particleboard between two sheets of tempered hardboard. This doubles the life of the benchtop. When the hardboard surface facing up becomes dirty and stained, remove the screws from the cleats, turn the top over and replace the screws.

Photos by Al Parrish

READY TO FINISH! Furniture Parts **CATALOG FREE**

CLASSIC DESIGNS by MATTHEW BURAK

Ready-to-Finish Furniture LEGS and Base KITS

Table Legs, Bun Feet
Kitchen & Bath Turnings
Table & Vanity Base Kits

www.tablelegs.com 800.843.7405
BOX 329, ST. JOHNSBURY, VT 05819

CLASSIC DESIGNS by MATTHEW BURAK

CIRCLE NO. 109 ON FREE INFORMATION CARD.

PORTABLE SAWMILLS

RIPSAW

Handheld portable band mill goes to the log where it lays. Mill weighs 45 lbs., cuts logs up to 20" dia., chainsaw powered, cuts up to 12 fpm, 9 x 14" throat, .025" narrow kerf blade. Larger mills available. Contact us today!

www.ripsaw.com

Better Built Corp.
789 Woburn St. Dept WJ
Wilmington, MA 01887
978-657-5636

CIRCLE NO. 106 ON FREE INFORMATION CARD.

You already know **BOSCH** power tools.

Now meet a **BOSCH** tankless water heater.

BOSCH AquaStar

Another BOSCH Innovation for Tankless Water Heating

When it comes to power tools, BOSCH has long been the brand of choice. Now, the same quality you trust in your tool chest is available in a water heater. This new technology generates the pilot spark from the flow of water. Like a hydro dam producing electricity, the 125HX system ignites the burners when water is flowing without the need for electricity or batteries. This patented technology provides the ultimate in efficiency, longevity, and simplicity of heating water.

- Endless Hot Water
- Save Energy & Money
- Built to Last
- Available in LP or Natural Gas

Exclusively distributed by:
CONTROLLED ENERGY CORPORATION | www.ControlledEnergy.com/pw | 800.642.3199

APPW

CIRCLE NO. 111 ON FREE INFORMATION CARD.

BW *The Woodworker's Edge...* **BRIDGEWOOD**

Quality is more affordable than you think!

TSC-10CL 10" Table Saw
the perfect table saw for contractors or smaller shops.
FEATURES: Left-tilting arbor reduces chance of kick-back. 1-1/2 hp motor with quick release connection plug. 10" dia. blade capacity. Miter gauge with T-slot. Large cast iron table with a solid extension wing. Beveled front table edge for smooth miter gauge operation. 4" dust collection hookup.

shown with standard Align-a-Rip® 30" capacity rip fence.

BW-002A Dust Collector
portable, compact unit can solve your dust collection problems at a very low cost
FEATURES: 2 hp motor. 1059 CFM. 1 Micron filter bag. 43.5 gallon collection bag. Bags attached with quick release metal straps. Metal impeller (not plastic).

BW-15BS 15" Bandsaw
don't let its low price fool you, this amazing bandsaw is designed and built to provide trouble free operation cut after cut.
FEATURES: Heavily ribbed cast iron frame. 3/4 hp motor is mounted directly to cast iron frame for smooth operation. Two blade speeds: 2000 or 2600 SFM. Cast aluminum wheels with rubber tires. Non-rocking steel stand. Miter gauge.

BW-15P 15" Planer
economically priced yet built like larger professional planers.
FEATURES: 3 hp, 3 knife cutterhead. Jackscrew knife adjustment. Enclosed base with wheels for mobility. 15" x 6" planing capacity. Table moves up and down - cutterhead stationary for smoother cuts. Three stock support rollers front and back. 2 speed feed rate. Magnetic switch.

BW-6R 6" Jointer
Acclaimed a "best buy" among 6" Jointers by a professional woodworking publication
FEATURES: 1 hp motor. 3 knife cutterhead. Jackscrew knife adjustment. Enclosed base with 4" chip collection hookup. Precision ground 6" x 45" cast iron tables. Rabbering table and ledge. Cast iron fence tilts in both directions to 45° with positive stops at 45° and 90°. Cast iron handwheels.

TOOL BUYING GUIDE
Editor's Choice

WILKE MACHINERY COMPANY
MACHINERY POWER TOOLS

QUALITY MACHINERY • PARTS • SERVICE • GREAT LEASE PLANS

For information and a **FREE** catalog contact us by toll free phone: **1-800-235-2100** visit our web page: **www.wilkemach.com** write or visit our showroom: 3230 N Susquehanna Trail, York, PA 17402-9716

CIRCLE NO. 161 ON FREE INFORMATION CARD.

INGENIOUS JIGS

continued from page 36

center divider (the beam). The resulting structure is very strong.

It's also very true, another important characteristic of a good bench. The benchtop should be flat if you are going to use it for precision work. I cut up the plywood sheets so the factory edge – the outside edge of the plywood as it comes from the factory – is the top of the center divider and the top of the two ends. As a rule, factory edges are pretty straight even if they appear a bit rough. When I attach the benchtop to the base and draw it down tight, the factory edges brace the top perfectly flat.

Making the Sandwich

The bench can be made almost any size – it's only limited by the size of the sheet materials you use. The dimensions shown in the plans are just suggestions – make the bench

Rout the dados using a T-square jig. The one shown here is designed to cut $\frac{3}{4}$ "-wide dados. First mark on your work the location of the dados. Line up the dado that's plowed in the T-square jig with your lines. Clamp the jig in place, set the depth of the cut on your router and make the dado.

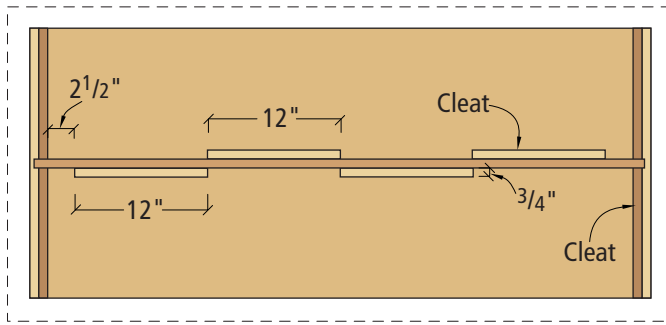
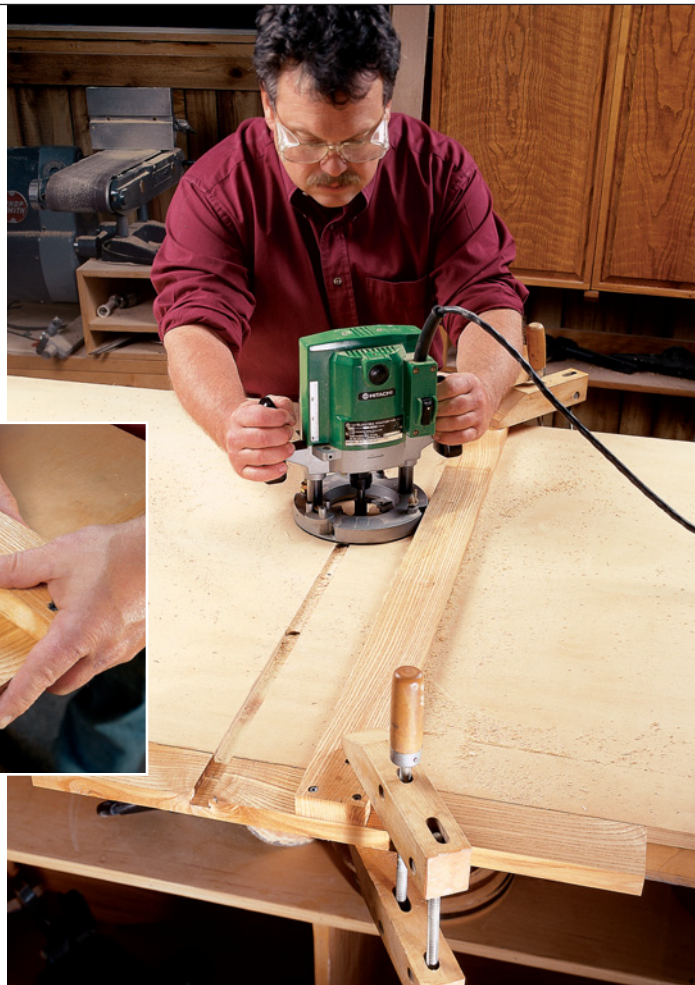

Plan

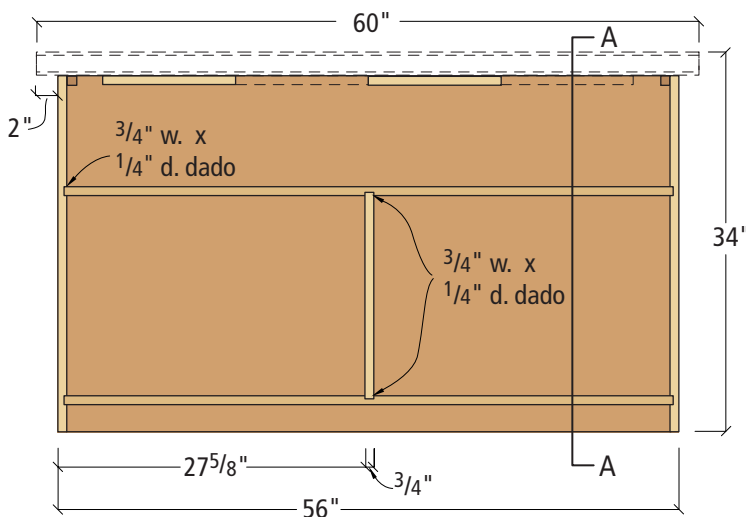

Elevation

Top laminated from two sheets of $\frac{3}{4}$ " particleboard and two sheets of $\frac{1}{4}$ " hardboard

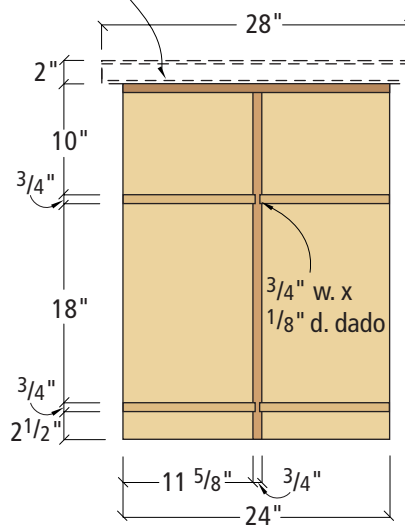

Section A

whatever size you need. Most craftsmen, I know, will immediately want to make the top a bit higher – 34" is somewhat low for a work surface for most people. But it works for me because I'm a short guy.

Once you've decided on the overall dimensions of the bench, cut the plywood parts and rout a few dados to help you assemble and align the parts. Cut the bench ends with three intersecting dados in each – one vertical dado to hold the center divider and two horizontal dados to hold the shelves. Make each of these dados $\frac{3}{4}$ " wide and $\frac{1}{4}$ " deep. Also make $\frac{1}{4}$ "-deep dados in the shelves to hold the shelving dividers. Then rout horizontal dados in the center divider, $\frac{3}{4}$ " wide and $\frac{1}{8}$ " deep. You must make these dados on both sides of the center divider – that's why they're only $\frac{1}{8}$ " deep.

Assemble the base parts with glue and screws (use pocket screws to attach the shelves

to the center divider). To make sure that the top edges of the ends and center divider remain true to one another while the glue dries, stretch two strings diagonally from the outside corner of one cap to the outside corner of the other.

The two strings should cross the base, forming a large "X." The strings should just kiss each other where they cross over the center divider, and they should rest lightly on the edge of the divider. If the strings aren't laying properly, level the parts of the workbench's base with small wedges and shims before the glue dries.

Topping the Sandwich

You can put a variety of tops on this base – I've used both butcher-block tops made from rock maple and less-expensive tops laminated from particleboard and hardboard. Any hard material about 1 $\frac{1}{2}$ " thick will do.

To attach the top, screw wooden cleats to the center divider and the ends, flush with the top edges. Position the top over the base and drive screws through the cleats and up into your top piece.

You can customize this work island to serve your own needs with vises, work lamps and other workbench accessories. The first thing I usually add are swivel casters to make the bench easy to move. If you want more shelves, drill $\frac{1}{4}$ "-diameter holes in the ends and shelving dividers for shelving support pins, then rest the shelves on the pins. To add drawers, mount guide rails to the ends and divider, then build wooden boxes to slide on the rails. **PW**

Nick Engler is the author of more than 50 books on woodworking, plus countless articles. Currently, he's helping kids across America build ribs for a full-size replica of the first true airplane, the 1903 Wright Flyer.

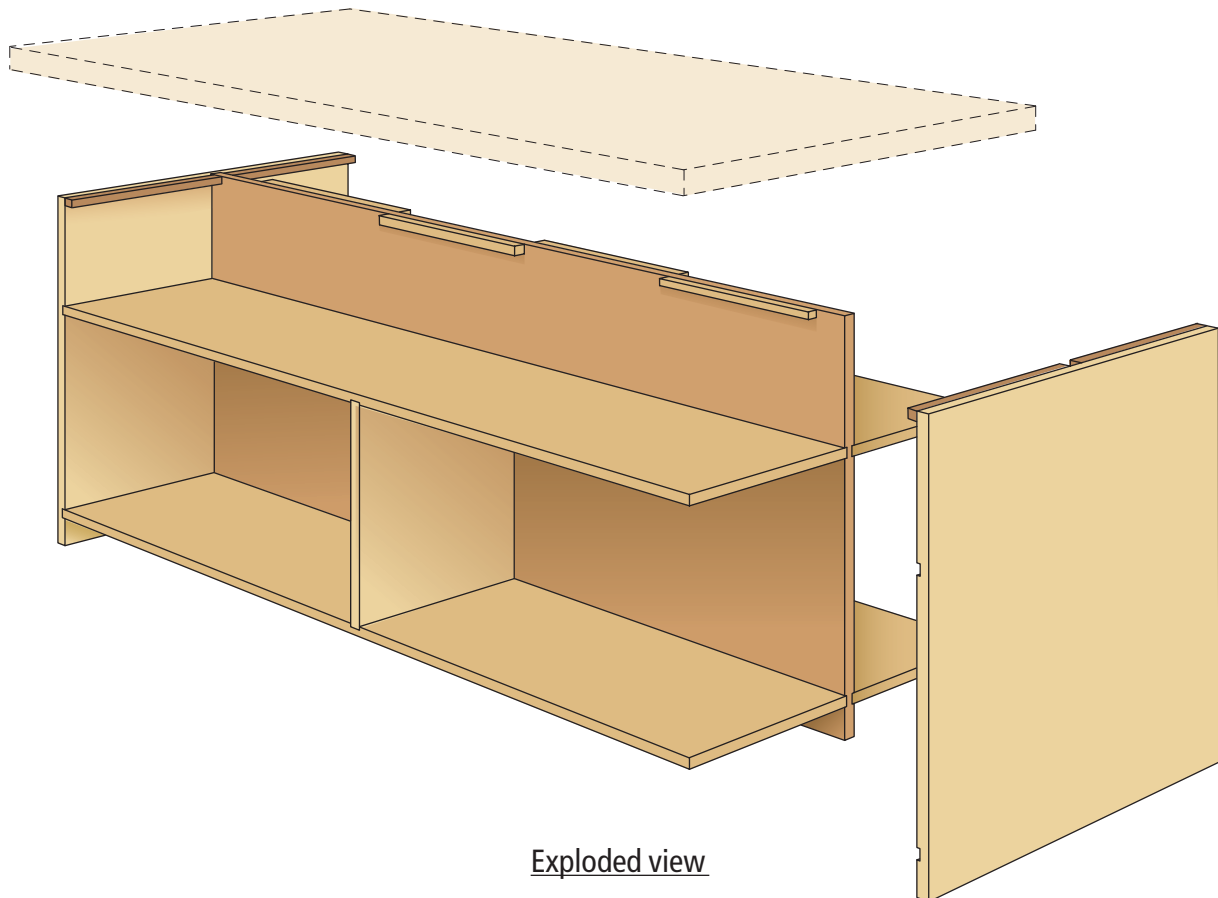

Exploded view



Kentucky Sideboard

Kentucky furniture is a style all its own, marked by solid, honest construction with a trace of whimsy in its ornamentation.

It's unlikely you'll find the "Kentucky Style" listed in any furniture-design textbook, but it's real. I've spent the last 15 years tracking down examples of this 18th- and 19th-century furniture style to study and incorporate elements of it into my own furniture pieces.

Kentucky furniture is less ornate than the pieces produced in the cities of its day, and this befits its frontier heritage. One of the things that sets Kentucky furniture off from other vernacular forms is the inlay that adorns the drawers and legs. While I've seen some examples of the Kentucky style with complex inlay designs, most times the inlay is simple and understated.

The furniture itself is usually made using walnut or cherry, two woods that are common in most parts of the Bluegrass state.

I've been building the sideboard design shown here for a number of years, and it has been received enthusiastically by my customers – no matter which side of the Mason-Dixon line they're from. A three-drawer version also is popular, and it is an easy change should you prefer that arrangement.

by Warren A. May

Warren A. May has been crafting solid-wood furniture and mountain dulcimers for more than 25 years. His showroom and dulcimer workshop is located at 110 Center St., on the College Square in Berea, the arts and crafts capital of Kentucky.



Photos by Al Parrish



I've made a simple mortising jig to help me locate the mortises in the sideboard legs. The jig is made from a piece of oriented strand board (OSB) and a couple of stop blocks screwed to the OSB that position the part to be mortised (above). A handscrew secures the leg against the stop block. I use a $\frac{3}{8}$ " spiral bit and my router's template guide to rout the mortise in several passes (right).



This sideboard is built using straightforward joinery and requires only 2"-square material for the legs. In deciding which inlay design to use, I pay careful attention to the wood grain, looking for the perfect flow of grain and contour. Just as with the authentic pieces of Kentucky-style furniture built in the 1700s and 1800s, I let hand-carved knobs and inlaid diamond escutcheons add a special flair.

Begin Construction

If you're interested in making your own version of this piece, I encourage you to try the inlay details. But if the sideboard itself is what you're after, I've offered the article in two sections. The main article shows you how to make the case, while the side-story explains the inlay work.

Start building the case by first marking the legs for the mortise-and-tenon joints in the face frame. These are the only mortise-and-tenon joints in the piece. The back and sides are held in place on the legs using biscuits.

To mark the mortise and tenon locations, measure down 2" from the top of each leg and mark for the top rail. Then measure another 7" down to define the drawer space and the location of the top of the lower rail. Go ahead and

KENTUCKY SIDEBOARD

NO.	ITEM	DIMENSIONS (INCHES)			MATERIAL
		T	W	L	
4	Legs	2	2	33 $\frac{1}{8}$	Cherry
2	Ends	$\frac{7}{8}$	13 $\frac{3}{8}$	13 $\frac{1}{4}$	Cherry
1	Back	$\frac{7}{8}$	13	42 $\frac{1}{2}$	Cherry
1	Top face frame rail*	$\frac{7}{8}$	2	43 $\frac{1}{2}$	Cherry
1	Bottom face frame rail*	$\frac{7}{8}$	4 $\frac{1}{2}$	43 $\frac{1}{2}$	Cherry
1	Center face frame stile*	$\frac{7}{8}$	2	8	Cherry
1	Top	$\frac{7}{8}$	18	48	Cherry
1	Backsplash	$\frac{7}{8}$	5	46 $\frac{1}{2}$	Cherry
2	Drawer fronts	$\frac{7}{8}$	7	20 $\frac{1}{4}$	Cherry
4	Drawer sides	$\frac{1}{2}$	7	16	Cherry
2	Drawer backs	$\frac{1}{2}$	6 $\frac{7}{16}$	20 $\frac{1}{4}$	Cherry
2	Drawer bottoms	$\frac{5}{16}$	15 $\frac{3}{4}$	19 $\frac{3}{4}$	Cherry
1	Support frame front	$\frac{7}{8}$	2	44 $\frac{3}{4}$	Cherry
2	Support frame ends	$\frac{7}{8}$	2	13 $\frac{1}{2}$	Cherry
1	Support frame center	$\frac{7}{8}$	4	13 $\frac{1}{2}$	Cherry
4	Drawer guides	$\frac{1}{2}$	$\frac{1}{2}$	15 $\frac{1}{2}$	Cherry
2	Drawer kickers	$\frac{7}{8}$	2	15 $\frac{1}{2}$	Cherry
1	Drawer support cleat	$\frac{7}{8}$	2	4	Cherry
2	Mounting cleats	$\frac{7}{8}$	2	41	Cherry
4	Drawer stops	$\frac{1}{4}$	1	2	Cherry

* Length includes $\frac{1}{2}$ " tenons on both ends.

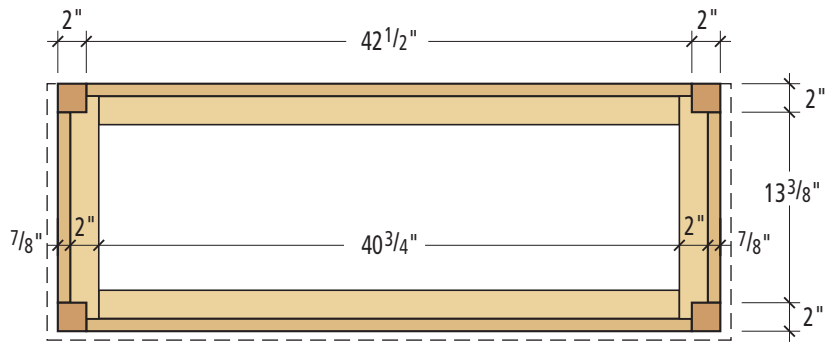

Plan - top removed

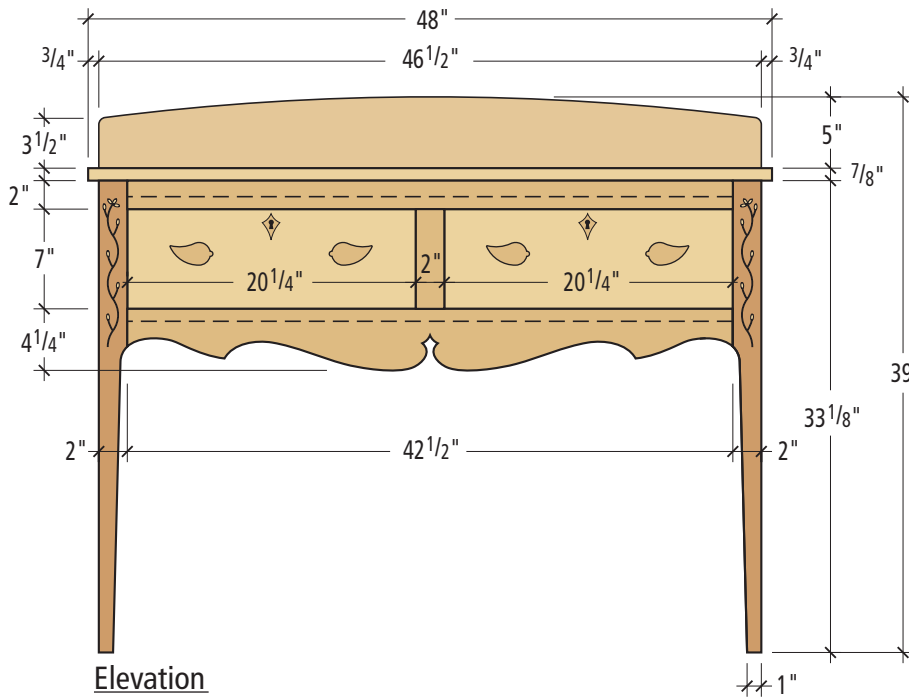

Elevation

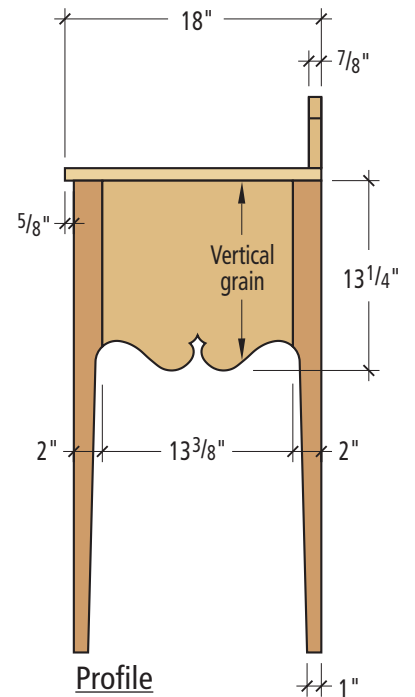

Profile

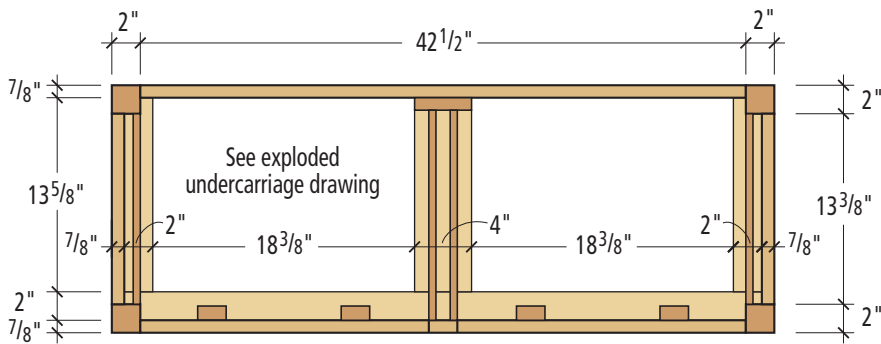

Plan - below drawers

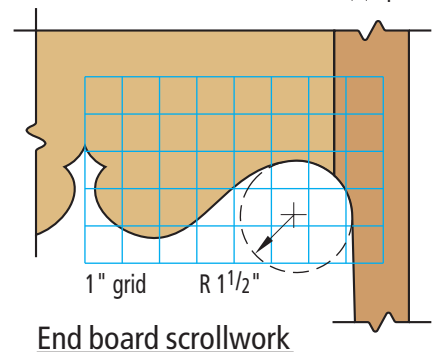

End board scrollwork

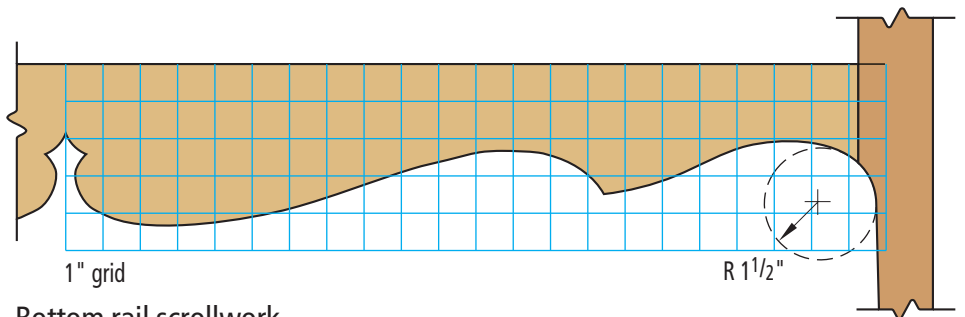

Bottom rail scrollwork

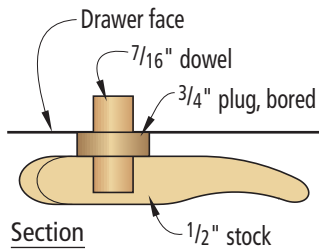

Section

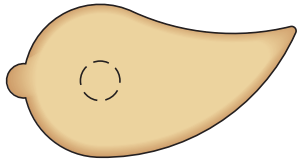

Half-scale pull details

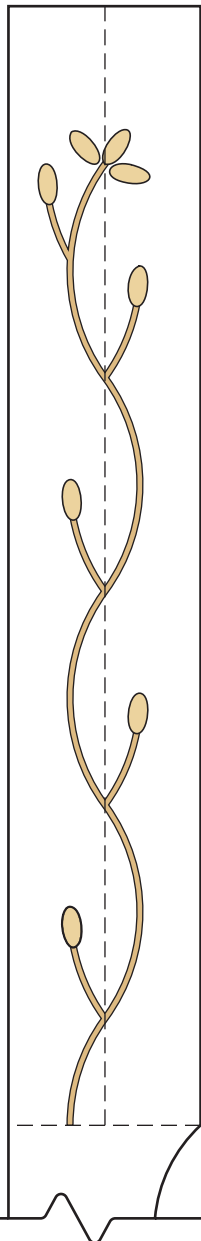

Half-scale inlay pattern

measure another $2\frac{1}{2}$ " and $4\frac{1}{4}$ " from the drawer space. The $2\frac{1}{2}$ " mark is the bottom edge of the mortise, while the $4\frac{1}{4}$ " mark defines the starting point of the leg taper where it meets the lower rail. See the illustration for details. The legs themselves taper on the two inside faces to 1" square at the foot. You should cut the taper prior to assembly using either a band saw or table saw.

The mortises are $\frac{3}{8}$ " x $1\frac{1}{2}$ " long x $\frac{1}{2}$ " deep and positioned so the front frame pieces are flush to the front of the legs. When making the mortises, add an extra $\frac{1}{16}$ " to the depth to ensure the tenons' shoulders seat tight against the legs. Cut the mortises in the legs and in the rails, which are for the center face-frame stile.

Now cut the tenons on the two face-frame rails and center stile, and use the scaled diagrams to cut the scrollwork on the lower

face-frame rail. Shape the transition from the rail to the leg.

If you're going to add inlay work to your sideboard, you should skip ahead to the section titled "Inlay, Kentucky Style" at this time and do the work on the legs prior to gluing up the carcass.

Now turn your attention to the two ends of the cabinet. The end panels are glued between the legs with the grain running vertically. With the panels glued up, crosscut the top edge to create a clean, straight line. Then mark on the ends where the legs should intersect – it's the same point where the scrollwork intersects the legs on the front.

Sketch the scrollwork pattern on the ends and cut it to shape on the band saw. Now glue the end panels between the legs, flush to the outside surface of the legs (this is a long-grain joint, but you can use biscuits to help align everything), and let things dry while you work on the back.

The back is a solid panel with the grain running horizontally

and is biscuited between the back legs, again flush to the outside of the back legs. Cut a pattern on the back that is similar to the pattern on the bottom face-frame rail, but without the diamond-shaped cutout or the horns beneath the drawers.

With the end assemblies, back and front frame ready, sand all your case parts and then glue the front frame, end assemblies and back together. Measure diagonally from leg to leg to determine if the case is square.

Supporting the Drawers

The drawer support frame is next. Notch the support frame front between the front legs so it fits tight against the bottom face frame rail. Now notch the two support frame ends around the back legs. These pieces should fit between the front support rail and be just short of the back. Overall you want the frame to be $\frac{1}{8}$ " shy of the rear legs and back to allow for wood movement in the end pieces.

The drawer support frame is assembled and attached to the case using screws. First drill and ream out a few holes in the support frame ends. The sloppy holes allow for wood movement. Now

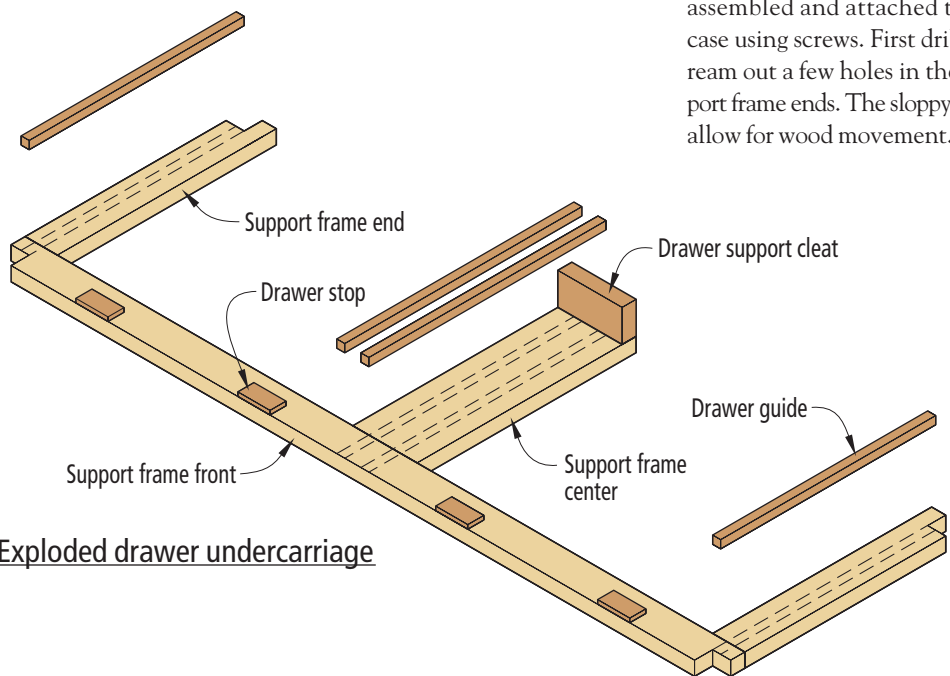

Exploded drawer undercarriage



After shaping the pattern on the bottom edge of the two ends, they can be glued between the two legs. I used two pieces of scrap wood to protect the legs during glue-up, but I always end up a hand short during these operations. So I taped the scrap pieces to the legs to keep them in place, hands-free. After the end assembly is dry, I took advantage of the ability to still lay the end flat and used a chip-carving knife to soften the edges of the scroll-work by adding a slight bevel (right).

drill several holes through the support frame front that allow you to attach it to the bottom face-frame rail. Now use screws to attach the front, ends and center support together as shown in the photo at right.

Glue and screw the support frame to the bottom face-frame rail, and screw the support frame ends to the end panels. Fasten the center support to the back with a cleat. The cleat is screwed to the back, above the center support, then screwed to the support, again using slotted holes to allow for movement.

Now notch and install the drawer kickers (which support the tops of the drawers). Attach these flush to the bottom edge of the top face-frame rail. Use the same method you used to attach the support frame end pieces.

Now is the ideal time to add the mounting cleats that attach the top to the case. Glue these cleats flush to the top of the case to the back and the top face-frame

rail. Drill holes in the cleats and kickers so you can screw the top in place. Note that there's no need to ream out these holes to allow for wood movement. The case will expand and contract from front to back thanks to the vertical grain of the ends.

Before you attach the top, you should build the drawers. You need to screw in some drawer guides and stops, and that's easier to do with the top off.

Drawers

Matched drawer fronts are a nice touch for this cabinet. Select a board wide and long enough to yield both drawer fronts. The drawers are of classical construction, using half-blind dovetails on the front-to-sides joint, and through-dovetails at the back. I hand-cut my dovetails, but it's up to you how you proceed from here.

The drawer bottoms are solid $\frac{5}{16}$ "-thick panels, fit into grooves cut $\frac{1}{4}$ " up from the bottom of the drawer front and sides. The back



The support frame is screwed together after being notched to fit inside the assembled carcass. Remember to leave space for wood movement on the end pieces. Also, it's important for smooth drawer operation that the support frame pieces are flush on the top surface. I clamped a scrap piece carefully across the joint during assembly to make sure the frame remained flush.

is $\frac{9}{16}$ " narrower than the sides, so the bottom can be slipped in from the rear, then attached to the drawer back. Once the drawers are built, screw in drawer runners to the support frame. Then screw $\frac{1}{4}$ "-thick stops that keep the drawer fronts aligned with the front of the face frame.

With the drawers fit, it's time to get the top ready to attach. The top is a simple flat panel, glued up as necessary to make the needed width. It extends over the front edge of the carcass by $\frac{3}{8}$ ", and $\frac{3}{4}$ " over each end and is held flush to the back.

Make a back splash the same length as the carcass, screwing and gluing the splash to the top.

The splash can be a simple large arch, or you can add a design of your choosing. Attach the top by screwing it to the cabinet through the two drawer kickers and the two cleats glued in earlier.

Adding a Finish

To finish the piece I used an oil finish to start. I applied one coat of oil, then let that dry for five days. I then sprayed two coats of lacquer sanding sealer, sanding with 240-grit sandpaper between coats, then I added another two coats of semi-gloss lacquer, rubbing out the final coat with #0000 steel wool. As a last touch I wiped the entire piece down with a layer of spray wax. **PW**



Once the carcass is assembled, add the top cleats and fit the drawer guides and stops. This is much easier to do without the top attached, so save that for the last.

INLAY, KENTUCKY-STYLE

Now you have the basic information to create a simple, but attractive sideboard. By adding some inlay to the piece, it comes to life.

My trailing vine and bellflower inlays have been most challenging. Even with routers, chisels and a variety of modern tools it is still slow work, but it is worth the effort.

Try line inlay with an Xacto knife with two blades in it. Or you can also rout a groove. I made a simple following template with a gentle curve, then I use a Rotozip with an added base with a strip of slick stuff on the bottom - a small guide slightly larger than the ground bits makes it easy to follow a curve (photo below left).

Next I cut a straight piece of rock maple in the table saw and rip it with a backing board on the band saw, slightly wider than the depth of the groove. I then glue the strip in place, using the head of my chisel to push the strip into place a section at a time. It usually looks better than you think it should (center photo, below).

If you're a beginner, try simple leaves. I start by cutting football shapes from a contrasting wood with a sharp gouge. I then cut the recess with the same tool and glue the "leaves" or "petals" in place.

Another method is to cut a leaf, diamond or bellflower design in a 2"-thick piece of maple,

then resaw the piece to the desired thickness on the band saw (photo right, below).

All of the inlays require a certain amount of hand-fitting. By leaving the inlay pieces proud of the surface, they're easier to handle, and I can complete the entire section before sanding everything flush. The bellflower has a second step. I use a torch to lightly burn the edges of the inlay to apply shading before gluing them in place in their recesses.

Don't be afraid to experiment, but you might want to make your first few attempts on test pieces rather than on a finished piece of furniture. You'll be surprised how easy it is.





This copy of a Spiers #7 smoothing plane from The Shepherd Tool Co. was built in about 12 hours using a kit. The only tools necessary to complete the job were a few files, a ball peen hammer, a drill press and a disk/belt sander.

BUILD YOUR OWN HANDPLANE

Photo by Al Parrish

With the help of a high-tech kit, almost anyone can now make a British-style infill smoothing plane – long regarded as the best plane design ever.

Ask almost any handplane enthusiast what they consider to be the best plane ever built and you'll usually get one answer: British infill smoothing planes.

These well-made traditional tools do a great job on almost any wood regardless of its figure, species or even grain direction and leave a glassy surface that's ready to receive a finish.

So why doesn't every woodworker in the world own one? There are several reasons. These planes haven't been mass-produced for about 50 years, the

good examples can fetch thousands of dollars in the collectors' market and the less-than-good ones aren't worth owning for the most part.

But now there's a quickly growing group of plane-makers who are reviving this once-heralded plane pattern and producing new versions for sale. For a fraction of what you'd pay for a real-deal vintage Norris or Spiers smoothing plane you can own a brand new copy that's ready to go to work.

Perhaps even more enticing (or frightening) is to build your own infill plane from a kit. For less

by Christopher Schwarz

Comments or questions? Contact Chris at 513-531-2690 ext. 1407 or chris.schwarz@fupubs.com. For more photos, go to popularwoodworking.com/features/mag.html.



Filing dovetails in steel is easy. All you need are a couple simple wooden guides to navigate your file through the cut. It took less than 30 minutes to file all the dovetails to the correct angle. Rubbing chalk on the files keeps the teeth from clogging; cutting only on the push stroke prevents you from ruining the file's teeth.

than \$370, you can get all the parts you need to construct your own high-quality smoother using just a few tools.

Last summer I decided to take the plunge and build a smoothing plane from a kit. After researching the two kits available at the time (there likely will be more on the market soon), I chose the Spiers #7 smoothing plane kit made by The Shepherd Tool Co. in Cambridge, Ontario. The Shepherd kit comes with all the wood for the plane shaped perfectly, and the metal shell is made using laser-cut steel plates that you dovetail together.

The competing kit available from the St. James Bay Tool Co. of Mesa, Ariz., comes with a single silicon bronze casting and you manufacture the wood parts yourself. The St. James Bay kit was enticing because it included a Norris-style blade-adjustment mechanism (not available on the Shepherd), but ultimately I decided I wanted to try dovetailing the metal sole, and that tipped the scales toward the Shepherd.

Fear of Metalworking

The Shepherd kit is supposed to take about eight to 10 hours to complete. I logged a few more hours than that, but I can be a

real nut about sanding and fitting. As I unpacked the steel plates and rivet pins, my first thought was: There was no way I was going to be able to file dovetails in steel.

Metal dovetails, however, turned out to be a blast. In fact, I wish wooden ones were as forgiving. Here's the deal. Once you file the ends of the pins and the tails to the correct angle using two simple jigs, you knock together the plane's sole and its side-walls. Then you secure this shell in a shop-made jig (the plans are included) and carefully beat the snot out of the dovetails using a ball peen hammer.

Peening is a real macho blacksmith-like experience. As you pound the protruding tails, the steel flows into the gaps to create perfect dovetails. If I could build drawers this way I'd be set.



Here's the shell before it's secured in a buck block for peening. Unlike wooden dovetails, steel ones snap into place.

This process, called "peening," causes the steel to flow – yes flow – into the gaps left by your less-than-perfect filing job. After peening and cleaning up your work using a file, the dovetails are so tight they're invisible.

Then you get to learn how to rivet as you secure the throat plate to the sole. The throat plate is a big hunk of metal that supports the blade and is one of the secrets to the plane's exceptional performance. With the sole plate riveted to the sole, the two wooden infills simply slide into the shell like a hand in a glove. I glued them in place using polyurethane

glue, then drilled holes through the sides of the plane and the wooden infill for more rivets – which secure the wood to the plane body permanently.

Filing Forever

Then comes the important drudgery: filing. With the plane clamped in a vise, I spent a good hour or two flattening the wood and metal bed for the plane's iron using a bastard file. Then I filed the throat of the plane (where the iron emerges) so the iron peeked out just a bit from the sole. Though some woodworkers say it doesn't matter, many contend that a tight





Riveting the infill to the metal shell is remarkably easy. First you file a small chamfer (about $\frac{1}{64}$ ") around the rim of your rivet hole using a rattail file. Then you place the rivet pin in the hole and peen both ends. File the rivet down and it's a seamless fit.

throat is another one of this smoother's secrets to success.

Lumpy, then Oooh La La

The rest of the work on the plane is sanding. At this point the tool didn't look like much. The sides and sole were lumpy. Plus the wood was boogered up from filing and shaping. But a few minutes on the belt/disk sander made a world of difference. Misshapen rivets and dovetails were abraded into a shiny metal surface with all the joint lines nearly invisible.

Maybe, I thought, it really was possible to build a metal plane.

The rest of the work was easy: sanding the cocobolo infill up to 600 grit, sharpening the awesomely thick iron and finishing the wood with a few coats of Defoil, an oil and varnish blend.

When completed, I secured the iron and chipbreaker in the plane's body and pulled out a weird board of curly cherry with the grain going in all directions. This, I thought, should be a good test.



Filing the bed of the plane takes a while, but it is worth every minute. A perfect fit between the iron and the plane helps ensure a chatter-free planing experience.

I pushed the plane forward and it responded with a swish and ejected a nearly transparent shaving 2" wide and 18" long. Not bad for a first pass.

After a little more tuning, the plane's performance can best be described as awesome. And though I'm thrilled with the tool, the best thing about the process was becoming comfortable with modifying my other tools. Shortly after I finished my plane I had a spoke-shave that was clogging. Either

the mouth was too tight or the lever cap needed to be polished. A few months earlier I would have hesitated to attack the tool with a file. But after just a few minutes of work, that tool began performing like it never had before.

And the downside to making your own tools? Once you get a taste of building a high-performance plane you can see why some woodworkers will settle for nothing less. So you make plans to build another one. **PW**

To file the mouth of any plane, clamp the tool nose down in your vise. Use a bastard file and take your time. Check your mouth occasionally with a combination square to ensure the opening remains square.

KIT SOURCES

The Shepherd Tool Co.
shepherdtool.com
519-624-7350

Also available from Woodcraft (woodcraft.com or 800-225-1153) and The Fine Tool Journal (207-688-4962).

A Spiers #7 smoothing plane in cocobolo costs \$365 plus shipping. Other woods, plane patterns and finished planes are also available.

St. James Bay Tool Co.
stjamesbaytoolco.com
800-574-2589

A similar Spiers smoothing plane kit (but with a blade adjuster) costs \$257 plus shipping. The unshaped cocobolo for the plane costs \$20 to \$30. Other plane patterns and finished planes are also available.

FINISHED PLANES

Museum of Woodworking Tools
toolsforworkingwood.com
212-604-9535

A finished reproduction of a Norris A5 smoothing plane built by Ray Iles costs \$550 plus shipping. Other planes available.

Sauer & Steiner Toolworks
905-272-2939 or 519-539-6364
Sauer & Steiner offers a full line of traditional infill planes, including a Spiers-type smoother. Call for pricing.

Holtey Classic Handplanes
holteyplanes.com
Considered one of the finest planemakers of our time, Karl Holtey makes a variety of new infills. A Norris A6 smoother costs about \$5,300.

Garage Golf Caddy

An attractive and easy-to-build storage solution for all the swingers and putters you know.

Although my shop keeps me busy, I still find time for hunting in the woods surrounding our home, fly fishing and lately, swinging some iron with one of my favorite golfing partners: my son, Josh.

Much like woodworking, as Josh and I have become more active in the sport of golf, our collection of golf-related paraphernalia has grown. Clubs, balls, tees and spikes began cluttering our family's garage and back hallway. (And you thought woodworking was expensive?) I decided a quick but sturdy cabinet would be the perfect garage storage solution.

This cabinet holds two golf bags with all our stuff at the ready for those days when the weather is perfect and cabinetmaking can wait. We just pull our truck forward a bit, load it up and head for the course.

This project is easy enough to build on a Saturday, ensuring ample time for the links on Sunday. Basically, the project works like this: The sides are dadoed to accept the top and

by Troy Sexton

Troy Sexton designs and builds custom furniture in Sunbury, Ohio, for his company, Sexton Classic American Furniture. Troy is a contributing editor for Popular Woodworking.





Photo by Al Parrish



The 6"-radius half-circles on the top piece are simple to cut out with a jigsaw. Your golf bag will neatly nest in this opening.

bottom. The two adjustable shelves hang on pins between the two partitions. Everything else is assembled using nails and glue.

At first, I was a little concerned with how stable the cabinet would be without a back. But as long as your dados are tight, I can assure you that your cabinet will be rock solid. The top back splash does an excellent job of adding rigidity to this open cabinet.

Selecting the perfect wood for a project is a lot like selecting the perfect iron to put a ball on the green. I chose oak for its durability, strength and relatively inexpensive cost.

Hitting the Fairway

First, cut all your parts to size according to the cut list. Make the miter cuts on the three pieces that make up the ball tray on the top.

Next, lay out your two 6"-radius half circles on the top piece, as shown in the diagram. These half circles cradle your golf bags. Your best bet is to use a piece of string attached to a pencil to lay out these curves. With the line

marked on the top, cut the curve using your jigsaw.

Now cut the $\frac{3}{4}$ " x $\frac{1}{4}$ " dados in the sides to receive the top and bottom. Lay your dados out according to the diagram. You can either use a dado set in your table saw or a straight bit chucked into your router to make these cuts. Dry fit the top and bottom into your sides, making sure the fit is tight. As I said earlier, a tight fit will ensure a stable cabinet. No need to take a bogie here.

Once your dados are cut, lay out the angles on your two sides according to the diagram. I cut these angles using my jigsaw, but a band saw will work, too.

Now it's time to drill the holes for the shelf pins so grab your drill and a 5mm drill bit. I use 5mm shelf supports instead of $\frac{1}{4}$ " shelf supports because the 5mm supports require smaller holes that don't stand out as much. You can purchase these supports at most woodworking stores or from catalogs. Woodcraft Supply, Lee Valley Tools and Woodworker's Supply are all good sources for



Here I'm dry fitting the carcass of my garage golf caddy. Tight fitting dados will ensure a stable project. And before someone writes me a letter, let me just say that I know that sandals are not a good choice for woodworking footwear.

this item. Don't forget that you'll also need a metric drill bit, which is also easy to find in most catalogs these days.

The holes are spaced 2" apart. Drill 12 sets of 5 mm holes on the inside face of each partition for maximum shelving flexibility.

Nearing the Bar

Before I assemble anything, I like to sand my projects to 180 grit. Sanding now will be much easier than waiting to sand after the project is put together.

First, assemble the top and bottom to one of the sides. Then

GARAGE GOLF CADDY

NO.	ITEM	DIMENSIONS (INCHES)			COMMENTS
		T	W	L	
2	Sides	$\frac{3}{4}$	16	42	
1	Bottom	$\frac{3}{4}$	16	47	
1	Top	$\frac{3}{4}$	10	47	Rip front at 10°
2	Partitions	$\frac{3}{4}$	$9\frac{7}{8}$	$33\frac{1}{2}$	
1	Splash	$\frac{3}{4}$	$3\frac{1}{2}$	$46\frac{1}{2}$	
2	Tray pieces	$\frac{3}{4}$	2	$8\frac{1}{2}$	Mitered
1	Tray piece	$\frac{3}{4}$	2	$14\frac{1}{2}$	Mitered
2	Adj. shelves	$\frac{3}{4}$	$9\frac{3}{4}$	$12\frac{3}{4}$	

add the other side. Next, using a finish nailer and glue, add the two partitions. Now add the splash. You could pocket screw the splash to the backside but I stuck with my nailer and glue and it's held up to abuse just fine.

Next comes the mitered tray pieces. Again, I just used my brad nailer and glue to assemble these. Attach the tray to the top using glue and a couple brads from un-

derneath the top. Finally, place your adjustable shelves in between the two partitions.

Once everything is assembled and dry, sand all your front edges and then spray the entire piece with a couple clear coats of lacquer or whatever finish you are most comfortable with.

Now it's time to hit the pro shop and fill all the shelf space you've just created. **PW**



Place your partitions using the diagram then nail them in with a finish nailer. A little glue helps, too.

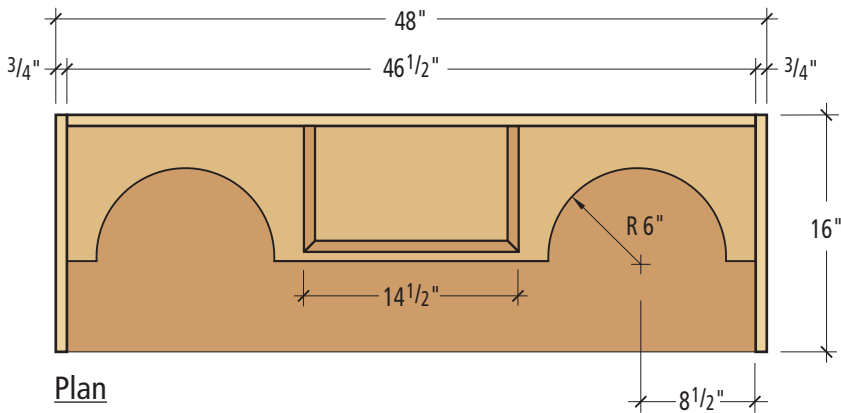

Plan

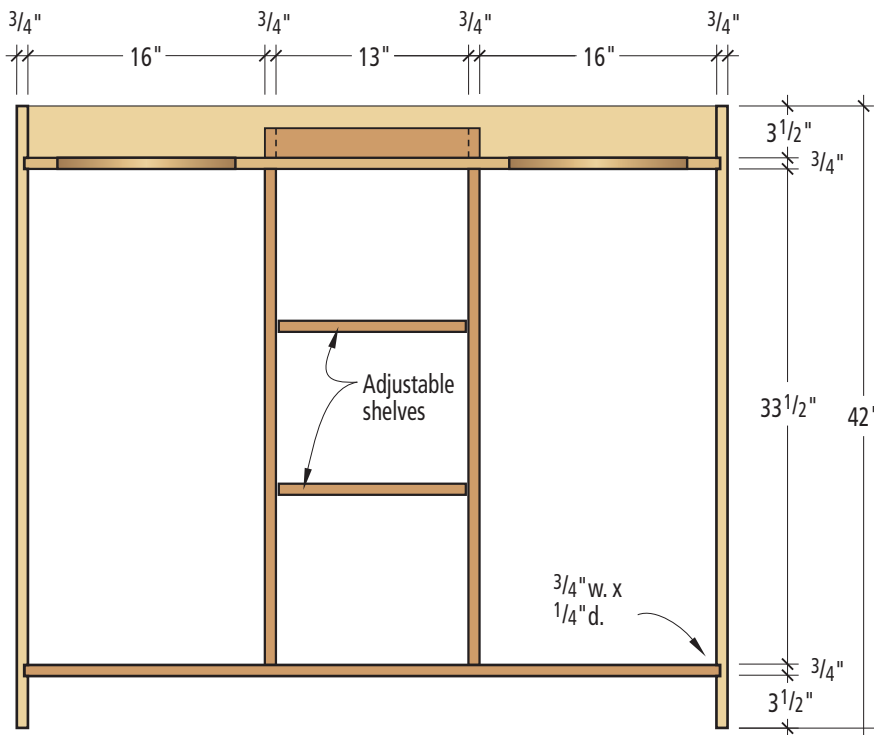

Elevation

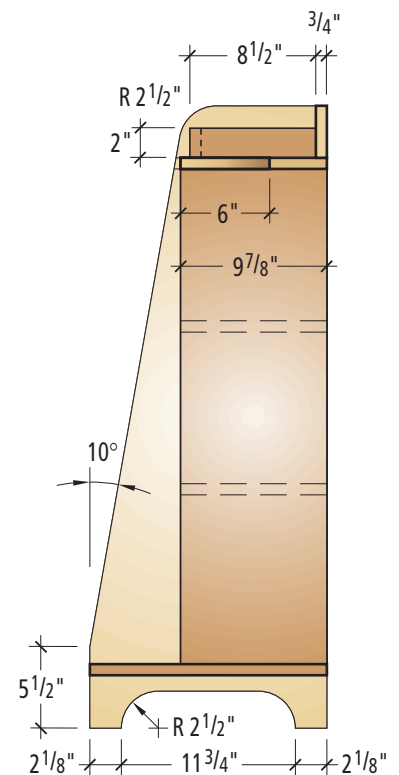

Profile

BUILT-IN BASICS

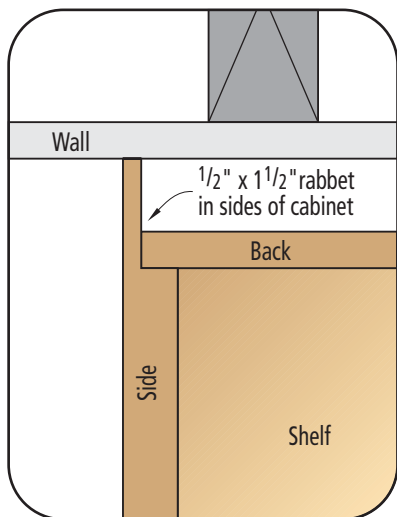

Back Rabet Detail

Plan view

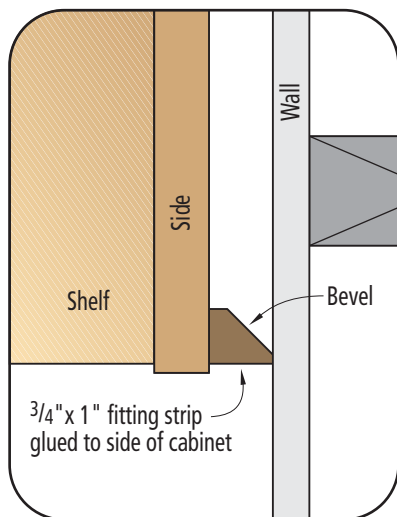

Simple fitting strip

Plan view

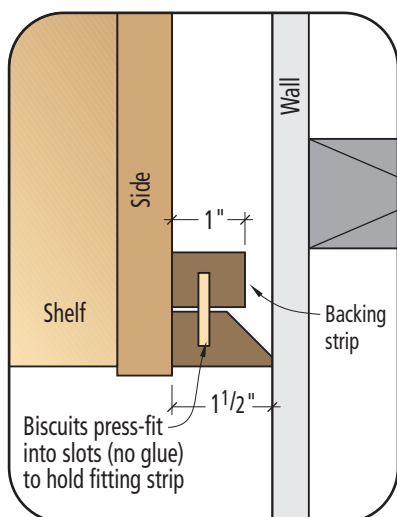

Complex fitting strip

Plan view

Making built-in furniture isn't tough. I've seen lots of first-time woodworkers build bookshelves that fit in the nooks by their fireplace.

But making built-ins that hug the wall, sit level and are anchored firmly to the house requires a little more know-how.

ably noticed that your rooms aren't all square and your walls aren't all plumb. This is usually the result of your house settling. It's also possible your framers or dry-wallers were sloppy.

Either way, don't build your cabinets crooked to fit a catawampus corner or sloping wall. Always build your projects square and add a couple features to allow them to fit in an irregular space. There are two tricks to accommodating out-of-whack walls: oversized back rabbets and fitting strips.

Making a built-in is easy once you understand scribing, fitting strips and French cleats. Here's a solid lesson in all three.

Big Back Rabbets

All cabinets should have a back that rests in rabbets in the sides of the case. This ensures a tight fit between the back and sides. With freestanding furniture, if your back is 1/2"-thick, then the rabbets for that back should be 1/2" wide. This is not so with built-ins.

You need to cut a rabet that is significantly wider. How wide? I usually make it between 1 1/4" and 1 1/2", depending on how out of kilter the wall is.

Luckily, with a little planning and a few modifications to the plans of almost any cabinet, you can make it a built-in. After trying different systems for making built-ins, this is the one that I prefer. It's simple, rock-solid and almost foolproof.

Cabinets in a Crooked House

If you've ever hung a cabinet or built in a few shelves, you've prob-

ably noticed that this large rabet does it creates two long tongues on the back of your cabinet that can

by Christopher Schwarz

Comments or questions? Contact Chris at 513-531-2690 ext. 1407 or chris.schwarz@fwpubs.com.

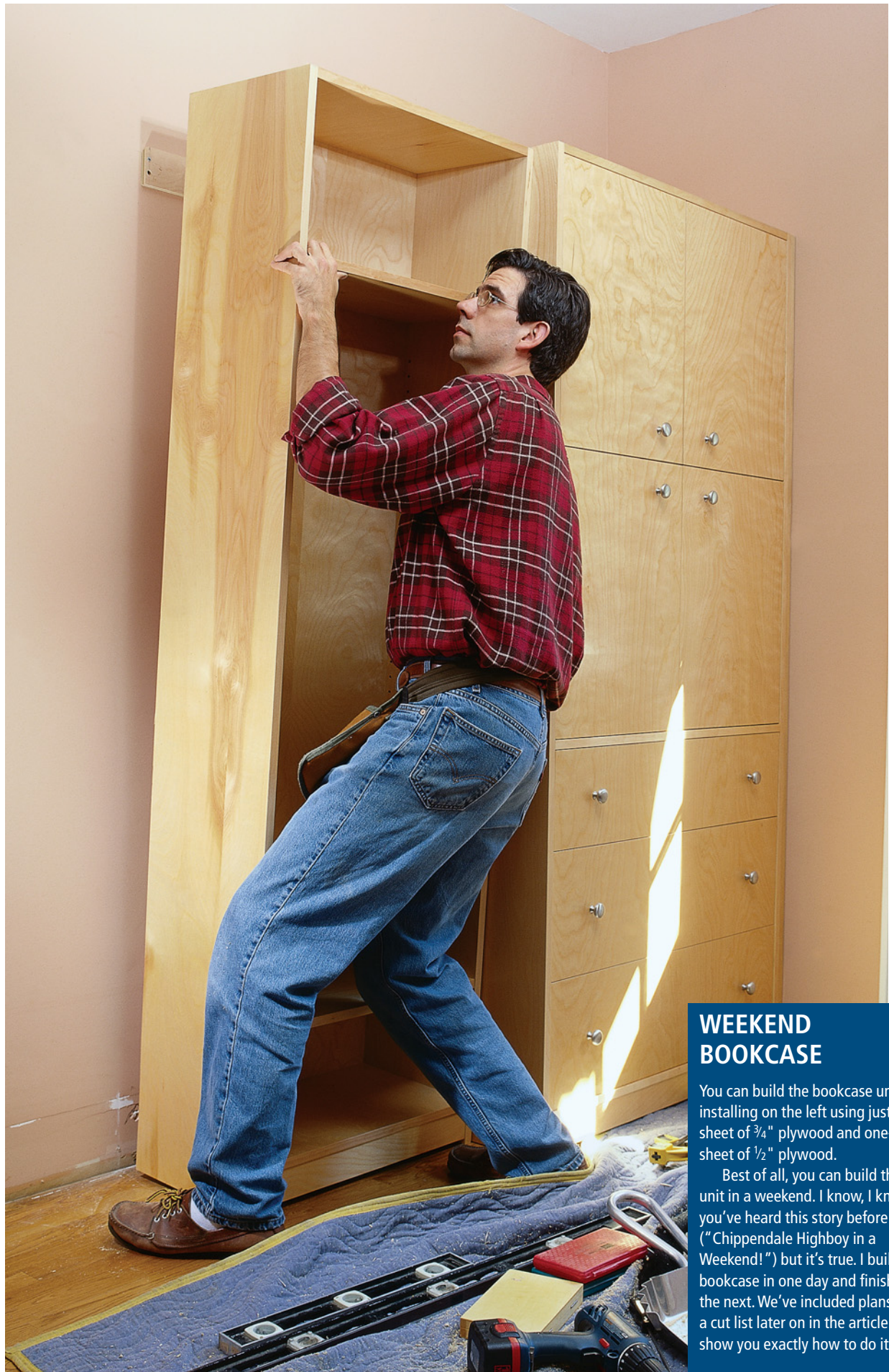

Photos by Al Parrish

WEEKEND BOOKCASE

You can build the bookcase unit I'm installing on the left using just one sheet of $\frac{3}{4}$ " plywood and one-half sheet of $\frac{1}{2}$ " plywood.

Best of all, you can build this unit in a weekend. I know, I know – you've heard this story before ("Chippendale Highboy in a Weekend!") but it's true. I built this bookcase in one day and finished it the next. We've included plans and a cut list later on in the article that show you exactly how to do it.

be scribed to fit almost any wall.

What's scribing? This is when you cut the edge of the cabinet so it matches the shape of your wall and fits tightly against it. Scribing isn't difficult, and I'll show you how I go about it later.

Fitting Strips, Scribe Stiles

"Fitting strips" and "scribe stiles" are two other weapons in your arsenal against the crooked wall. They are a lot like the large rabbets on the backside of your cabinet, except they help fit the sides of your cabinet to a wall or to another adjacent cabinet.

If you are building and installing a face frame cabinet, your best bet is incorporating a scribe stile into your design. With this technique you make your face-frame stiles (the vertical pieces of the frame) wider so they extend out over the sides of the cabinet by $\frac{3}{4}$ ". Cut a rabbet on the backside of the stiles, which makes them easier to scribe to fit, and you then have a seamless way of attaching your cabinets to walls or to other cabinets.

If you are building a cabinet without a face frame then you should turn to the fitting strip.

Fitting strips are attached to the cabinet sides and are cut to fit against a wall. Typically you cut a 45° angle on the backside of the $\frac{3}{4}$ " x 1" fitting strip so when you scribe it there is a lot less material to cut away. There are a variety of different ways to attach a fitting strip to a case. Whatever method you use, avoid using metal fasteners because they could get in the way when you scribe and then trim the fitting strip to size.

If the case is small, you can simply glue the fitting strip to the side of the case. If the case is large, you should come up with an alternate plan. It's no fun turning a big case on its side, trimming a little more and then setting it back up over and over again.

One solution is to glue a backing board to the cabinet behind the fitting strip that is a little narrower. Then you attach the fitting strip to the backing board using several biscuits but no glue. This allows you to set the cabinet against the wall, mark your scribe, cut it and then put the cabinet in place. Then you fine tune the fit by pulling the strip out for more trimming. See the drawing on the previous page.

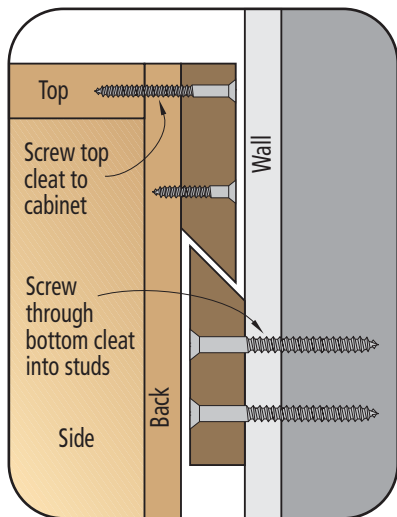

French cleat detail
Profile view



There are a wide variety of cabinet levelers you can buy, but they all basically work the same way. Many of them are adjustable at both the foot and from above through an access hole you drill in the cabinet's bottom. This feature is a huge convenience when leveling your cabinet on an uneven floor.

Attaching it to the Wall

The other big issue when installing a built-in is how you actually attach it to the wall. There are a number of ways to do it. Some people simply run some long screws through the back and into the studs. This works, but the screw heads are visible inside the cabinet, and you must use really long screws to reach into the studs across your big back rabbet.

Another solution is to install a hanging strip inside your cabinet. The hanging strip is usually a piece of $\frac{3}{4}$ "-thick material that is about 3" wide and is nailed or biscuited between the sides – right beneath the top. With this system, you attach the cabinet to the wall through the hanging strip using countersunk screws, which you can then plug to hide them.

The system I prefer uses a French cleat. It sounds complicated at first, but once you get it straight in your head you'll see it has some advantages.

The French cleat uses two cleats, each with one long edge beveled at 45°. One of the cleats is screwed to the wall and the other is screwed to the back of the cabinet. The two 45° angles nest together, locking the

cabinet to the wall. This is a common way to hang kitchen wall cabinets, but I've found it's great for hanging cabinets that go to the floor, too. And I've come up with a method that makes it easy to do. But before you can install any cabinet, the first thing you have to do is get it sitting level on the floor.

A Word About Cabinet Bases

When building large cabinets, it's best to build a separate base from the cabinet itself that is about 3" to 4" in height. You can then set the base in place and level it using wooden shims or leveler feet. Leveler feet are a piece of hardware that attaches to the inside corners of your base and have feet that screw up and down. You adjust the feet until the base is level and then set the cabinet on top of the base and move on to the section on scribing.

With smaller cabinets, such as the bookcase shown here, you can skip the separate base and install the leveler feet under the bottom shelf or use shims to level the entire cabinet. Either way, you must get the cabinet level left-to-right and front-to-back before you proceed.



Once the cabinet is level front-to-back as well as left-to-right you can plug the holes you drilled to access the leveler hardware. Many brands of levelers come with their own plastic plugs, though a shop-made tapered wooden plug works just as well.

Scribing

Scribing isn't difficult, but it requires practice. The first thing to do is take a look at your cabinet. If it is going in a corner, then you should remove the big back rabbet that goes into the corner – it's only going to get in the way of scribing the other rabbet and the fitting strip (if you have one).

Now push the cabinet back against the wall or walls until some part of the cabinet meets the wall. It's time to mark a scribe line on your back rabbet. Get a compass that allows you to lock the swinging arm. Using a ruler, find the biggest gap between your wall and cabinet. Set the distance between the pencil and the point of the compass to this distance.

Now trace the shape of the wall onto the back edge of the cabinet. Use the point of the compass to follow the wall and let the pencil draw that shape onto the cabinet. Keep the compass level.

In the photos, you'll see I use a European-style scribing tool instead of a compass. This piece of red plastic costs about \$8 (ouch), but it's a lot easier to handle than a compass. This scribing tool is sold as the McGrath Scribe and

Profile Gauge, and it is available from Diefenbacher Tools, 800-326-5316 or diefenbacher.com. Ask for item # 663-1000.

Once you've drawn your scribe line, trim the back rabbet to that line. You can use a jigsaw followed by a hand plane, a belt sander or even a hand-held power planer. Test the fit of your scribe line to the wall and make any necessary corrections.

Once the back is fit, scribe the fitting strip (if you have one) where the front of the cabinet meets the wall. Once everything fits snugly, attach the case to the wall using your French cleats.

Installing French Cleats

It's simple to get a perfect fit with these cleats if you follow these steps. I like to use plywood or any tough hardwood such as maple for the cleats. First rip your two cleats to about 3" wide and cut them to length so they're about 1" shorter than the width of the back of your cabinet. If your back piece is 23½" wide, then cut the cleats to 22½" long – this gives you some left-to-right play during installation.

The first step is to install a

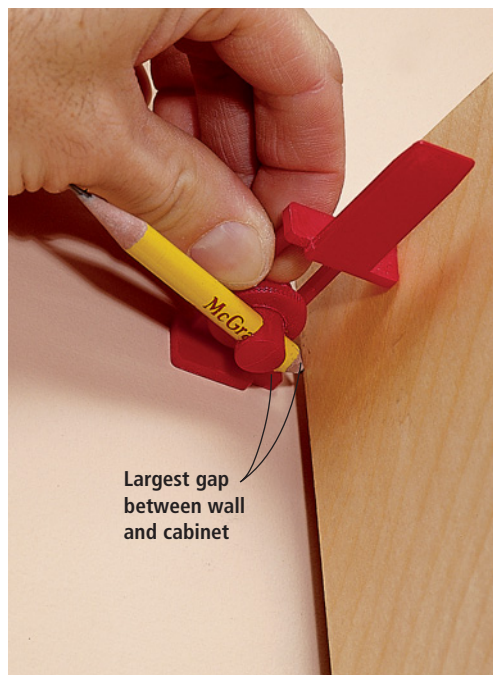

To set your scribing tool, use a ruler to find the biggest gap between the back edge of your cabinet side and the wall. Set your scribe to span this distance exactly. Now run the scribing tool up the back edge of your cabinet – being sure to maintain contact with both the wall and cabinet. The pencil will draw your cut line on the back edge of the cabinet side.



Many professionals use a belt sander to remove the material down to the scribe line. Belt sanders are a little too speedy for my tastes. I prefer to use a jigsaw to cut right up to the line and then clean up the cut with a block plane. It's still quick, and there's little chance of obliterating your scribe line.



Install the first French cleat to your wall using the longest screws available. These screws must anchor the cleat into the stud wall of your house, or the cabinet could come toppling down if someone tries to climb it.

cleat on the wall so it's perfectly level and about 2½" below where the top of the cabinet will touch the wall. Screw the cleat to at least two studs in your wall using #10 x 3" screws.

Now push the cabinet in place against the wall and use a stepladder so you can work on the top of the cabinet. Take the other cleat and drop it behind the cabinet and push it into place with the bevel facing the back of the cabinet. It should drop into place with ½" or so sticking above the top of the cabinet. Mark a line on the cleat where the back and cleat intersect. Lift the cleat out and rip the cleat to width exactly to your line.

Pull the cabinet away from the wall and screw the cleat to the backside of the cabinet so the top edge of the cleat is perfectly flush to the top of the cabinet.

With the help of an assistant, lift the cabinet a few inches and place it on the cleat on the wall. The cabinet should sit flush against the wall, flat on the floor and refuse to rock or move.

If the cabinet doesn't sit on the floor, remove one cleat and shave off a tad from the bevel with a hand plane or a jointer. Or you can adjust the leveling feet. If the

cabinet rocks a bit on the cleat, add a short strip or two of masking tape to the bevel on one cleat and that will tighten things up.

There's another type of cleat that some prefer. Instead of ripping a 45° bevel on each long edge. The rabbet should be exactly one-half the thickness of the cleat so that the cleats nest together like a shiplap joint.

Install the first cleat against the wall. When you attach the second cleat to the cabinet, nudge it up ⅛" and then screw it in place. This will prevent the rabbets from bottoming out when they nest and will give you a little play when the cabinet rests on the floor.

Cleaning Up

With the cabinet in place, you might have to screw one of the side pieces to a wall to pull the cabinet tight against the wall.

The cabinet is now complete, except for any trim around the base and crown. To finish the run of cabinets shown at the beginning of the article I still need to build and install another large unit with drawers and doors. Then comes the trim moulding. And then comes a cold beer. **PW**

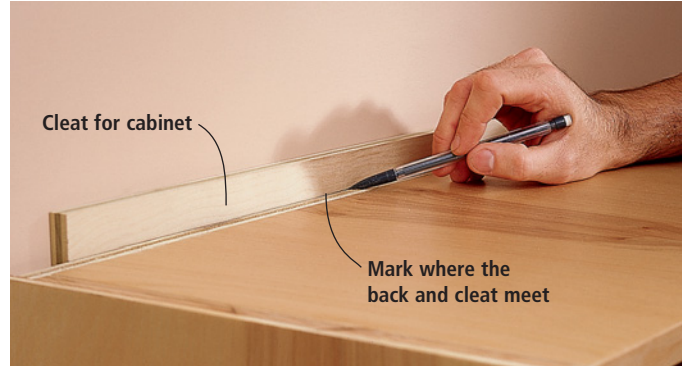

With the back rabbet scribed and a cleat screwed to the wall, push your cabinet in position and drop the second cleat in place behind the cabinet back. Using a sharp pencil (top), mark a line on the cleat where the cabinet back and cleat meet. Remove the cleat (bottom) and rip it to width. If you had to scribe near the top of your cabinet, you might have to plane down your cleats a tad, too.



Clamp your cleat to the back of the cabinet with the top edges of the cleat and cabinet back perfectly flush. If they're out of kilter you're going to make trouble for yourself, so take care. Screw the cleat to the cabinet using long screws that you countersink into the cleat.

THE ONE-WEEKEND BOOKCASE

When I build a project for my family, I'll come up from the shop and the first words out of their mouths are usually something like: "Aren't you done making my (corner cabinet, entertainment center, Morris chair, carved weasel) yet?"

Well this time the joke was really on them. I went down to the shop at 8 a.m. one morning and by 5 p.m., this bookcase was sanded, assembled and ready for finishing. They were shocked.

There's nothing fancy about this basic bookcase unit, but it does hold a ton of stuff, is inexpensive to build (about \$70 in materials) and goes together as fast as a highboy on "The New Yankee Workshop." Well, OK, it's not quite that fast.

Follow the photos and drawings to build your own. But be forewarned. Once you build something this fast, your family is going to think you spend most of your time in the shop just goofing off.

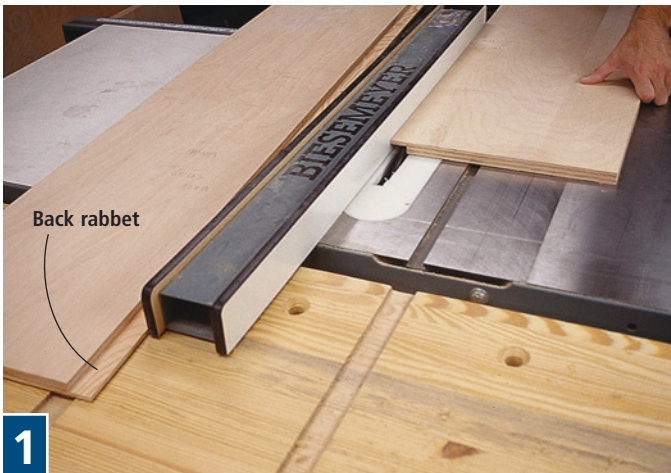

1

Begin by cutting the big $1\frac{1}{4}$ " x $\frac{1}{2}$ " back rabbet on the back edge of the sides. The most accurate way to make this rabbet is by using a dado stack in your table saw. Make a couple passes and be sure to keep even downward pressure.

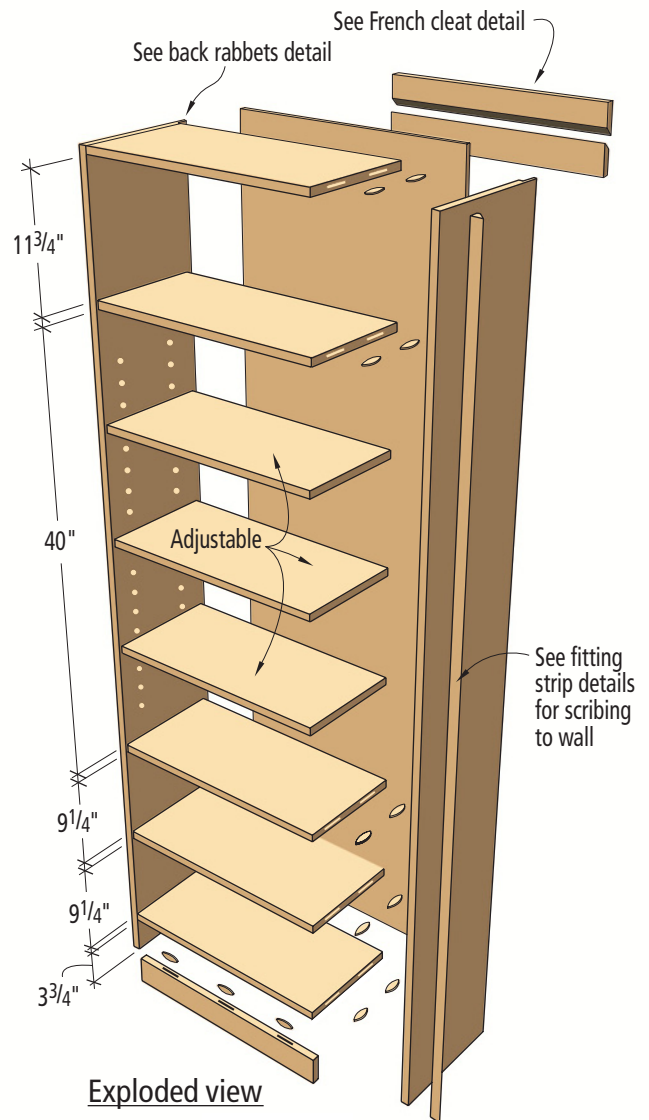

THE ONE-WEEKEND BOOKCASE

NO.	ITEM	DIMENSIONS (INCHES)			MATERIAL	COMMENTS
		T	W	L		
□ 2	Sides	$\frac{3}{4}$	12	80	Plywood	$\frac{1}{2}$ " x $1\frac{1}{4}$ " rabbet for back
□ 2	Top and bottom	$\frac{3}{4}$	$10\frac{3}{4}$	$22\frac{1}{2}$	Plywood	Biscuited into sides
□ 3	Fixed shelves	$\frac{3}{4}$	$10\frac{1}{2}$	$22\frac{1}{2}$	Plywood	Biscuited into sides
□ 3	Adjustable shelves	$\frac{3}{4}$	$10\frac{1}{2}$	$22\frac{3}{8}$	Plywood	
□ 1	Kick	$\frac{3}{4}$	$3\frac{3}{4}$	$22\frac{1}{2}$	Plywood	Biscuited into bottom
□ 1	Back	$\frac{1}{2}$	$23\frac{1}{2}$	78	Plywood	
□ 1	Fitting strip	$\frac{3}{4}$	1	80	Plywood	Use if unit goes in corner
□ 2	French cleats	$\frac{3}{4}$	3	$22\frac{1}{2}$	Plywood	45° bevel on one long edge

You can download an optimization chart for this project at: popwood.com/features/mag.html

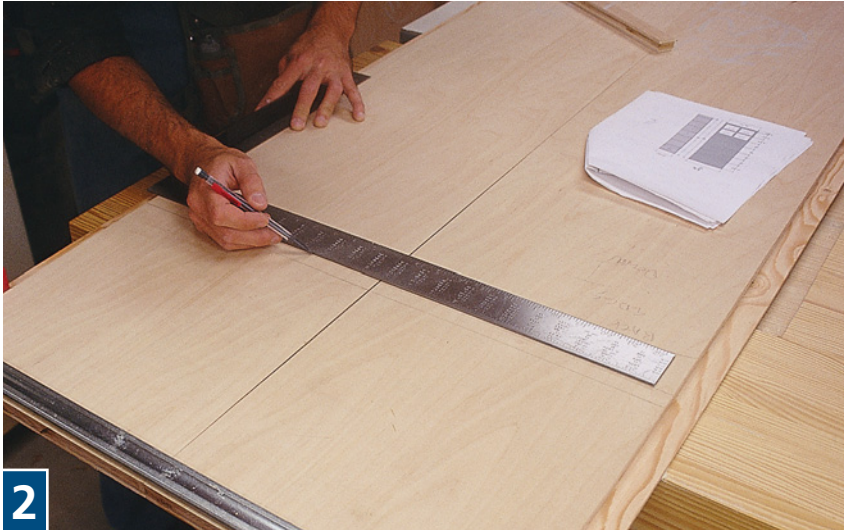

2

To lay out the location of your shelves, clamp the two sides together and use a framing square to mark the shelf locations. Use the drawing to lay out the locations of the fixed shelves, top and bottom pieces.

If you work in a small shop (like I do) the No. 1 challenge with a piece of furniture like this is cutting down the plywood into manageable sizes for my table saw.

Luckily, Nick Engler showed me how to do it quickly and accurately. Engler made a simple platform from 2 x 4s that you place on two sawhorses in your driveway. Using a special shop-made fence and a circular saw you can make perfect cuts in sheet goods.

The original article appeared in the April 2001 issue. If you don't have that back issue, we've posted this article on our web site at popularwoodworking.com. When you get to our home page, click on "Select Articles," scroll down and you'll see the article titled "Sawing Plywood and Particleboard."

I've built many cabinets using this simple jig and highly recommend it.

Screws or Biscuits?

I built this project using biscuits and a 1/2"-thick back, which makes the case quite rigid. Another possible approach is to screw the fixed shelves in place through the side pieces using #8 x 2" screws.

If the sides of your bookcase aren't going to show (or you don't mind the look of plugs) this is a solid way to make a bookcase.

One final option I'm fond of with large cabinets is to use both biscuits and pocket screws together. This hybrid system is about the fastest and most accurate way I know to build a case.

First cut the biscuit slots, then cut the pocket holes on the underside of the shelves. Glue up the case and then drive the screws home. The biscuits line up all your joints perfectly, and the screws allow you to do this all without any clamps at all. **PW**

SUPPLIES

Lee Valley Tools
800-871-8158
leevalley.com

Cabinet Levelers, One-ton Glide
Each glide is rated for 2,000 pounds. Foot adjusts over a range of 2 1/4".
Item # 01508.01, \$3.70 each

Nickel-plated Shelf Supports
Item # 94204.02, \$3.50 for a package of 50.

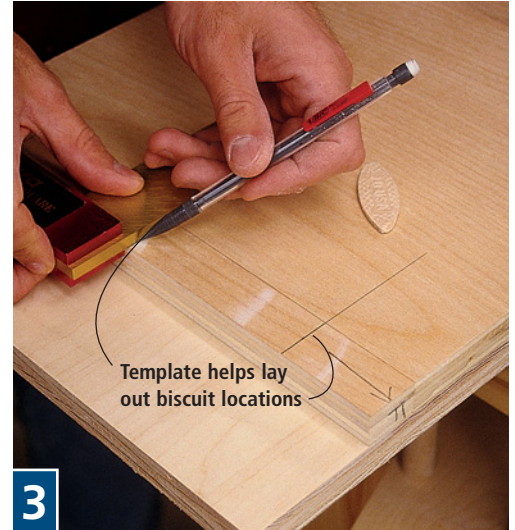

3

Template helps lay out biscuit locations

All the permanent shelves are attached to the sides using biscuit joints. Clamp the shelves at the location where they will join the sides. I then made a simple template to lay out the locations of my biscuit slots. This saves a lot of measuring.



4

Take the fence off your biscuit joiner (or retract the tool's fence fully into the fence assembly). Cut three biscuit slots in the shelves as shown. I used #10 biscuits because I was out of #20s.



5

Now turn the biscuit joiner on its head and cut the slots in the sides pieces of the cabinet.



6

Iron on some adhesive edge-banding to cover all the visible plywood edges. Use a household iron set on "high." After a couple minutes of ironing, take the iron off the tape and use a sizable block of wood to rub the edging down. The wood acts as a heat sink to cool the adhesive and set the edge-banding in place.

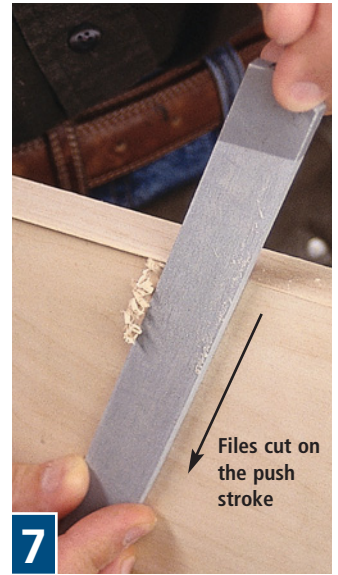

7

Files cut on the push stroke

Use a file to trim the overhang of the edge-banding. Remember that files cut only in one direction. Move them the other way and they'll cut poorly and dull quickly. Now sand all your parts at 150 grit and then 220 grit.

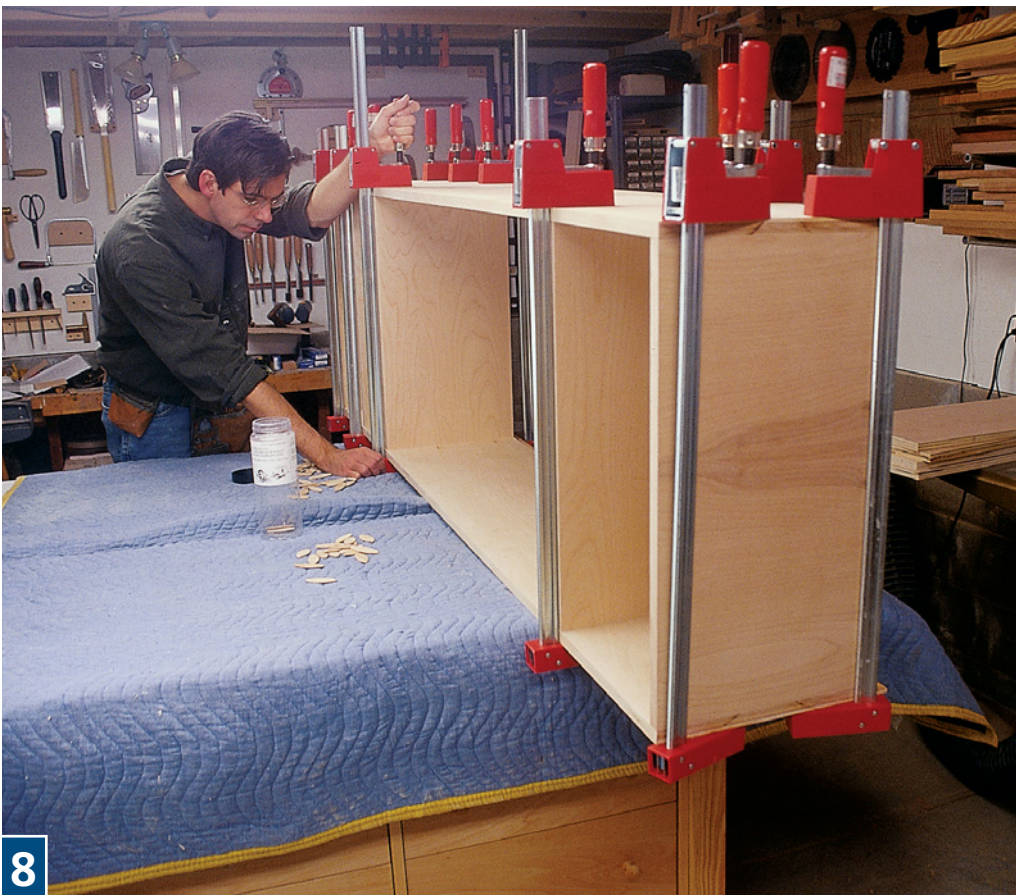

8

Always do a dry run before gluing up your case. Once you're sure everything works, use a slow-setting glue. I have become quite fond of the new Titebond Extend glues. They are very strong and give you just enough working time to get a big case together by yourself. Once the glue is dry, cut the back to size. You want a perfect fit because the back will keep the cabinet square once it's screwed in place.



9

Drill your shelf pin holes every 2" on center. You can use a commercial jig like the one shown or make your own from scrap. Then attach the kick to the bottom using glue plus biscuits or pocket screws. I finished the bookcase with two coats of spray lacquer in the backyard on a nice breezy day.

12-VOLT DRILLS



**What to buy and
how to use them**



After testing 16 professional- and consumer-model drills, we know that 12 volts is enough for woodworkers, and there are lots of quality tools to choose from.

Cordless drills are pretty amazing. They're portable, pack lots of power and have features that most corded drills don't offer. They get less expensive every year, and the competition is so tight that there are lots of great products available. But they're not all created equal, and we tested a bunch of them so we can tell you which ones to buy.

Putting Them to the Test

When we test tools at *Popular Woodworking*, we like to say it's real-life testing. Monitors and fancy machinery can tell you many things, but what you really want to know is how much work you'll get out of the tool. For our test we completely discharged each battery, then recharged, then discharged the battery again. After one more complete charge we were ready to test. One note: A few of the manufacturers' instructions indicated that the drill might not reach maximum charge capacity until after five or six complete charges. Our testing parameters started all the drills at the same point, but some of the drills may perform slightly better after continued charging.

For the first test we took a brand new $\frac{1}{2}$ " Speedbor spade bit (one for each drill) and started drilling holes completely through $1\frac{1}{2}$ "-thick poplar boards. Because the amount of force and speed applied in a drilling process can alter the results in such a test, we had two editors (one male, one female) repeat the tests, then we averaged the completed holes on one battery charge.

All drills were tested in the high-speed range setting (when available) and with clutches set to zero torque resistance (or screwing mode).

For the second test, we sank $\frac{1}{4}$ "-diameter by $1\frac{1}{2}$ "-long lag bolts into $1\frac{1}{2}$ "-thick cabinet-grade plywood. This test was performed with the drills' speed setting on low, providing maximum torque, and again with the clutches set on zero torque resistance.

Finally we took a look at the ergonomics of the drills. Each member of our staff evaluated the grip, balance, ease of use for the battery release, chuck, clutch and variable-

by David Thiel

Comments or questions? Contact David at 513-531-2690 ext. 1255 or david.thiel@fwpubs.com.

speed triggers, and came up with an average rating for each drill. We then averaged all the individual scores and came up with an ergonomic rating for each drill.

We also decided to divide the drills into consumer and professional categories to fairly compare apples to apples, but our testing also lets you see how the consumer models compare to the pros.

Initial Reactions

Overall we reinforced our opinion that 12 volts is more than enough power for every task in a wood shop. We also determined that single-speed drills aren't as versatile or useful as multi-speed drills, and if the price is nearly the same, opt for multiple speeds.

Whenever possible, a "smart" charger is preferable. Smart chargers offer a maintenance or trickle-charge after completely charging the battery, allowing you to leave the battery in the charger without causing any reduction in battery performance.

Our preference is for single-sleeve chucks with a "locking clutch." Single-sleeve chucks

have a locking motor shaft and a single chuck sleeve to tighten the chuck, while two-sleeve models have a free-spinning shaft and require two hands to tighten the chuck. A locking clutch makes a clicking noise as it tightens completely against the bit (sort of like locking the gas cap on your car).

Another preference is for a lighter and well-balanced drill, but only when in tandem with adequate power and performance.

We've included stated torque statistics from the manufacturer in the chart below, but we found during our testing that those torque ratings tend to be a maximum torque, not continuous torque. The maximum torque will help you break loose a stuck bolt, but when sinking a bolt in 1½"-thick wood, the drill can't exert continuous maximum torque.

Features, Pro & Con

It's important to mention a couple features here that may or may not be important in your purchasing decision. Many of the consumer models offer some type of level built in to the drill. This

may be a useful feature if you're a first-time, or very occasional cordless drill user, and as such this feature belongs on the consumer drills. Once you get comfortable with a cordless drill, this feature becomes superfluous.

All the drills tested include two batteries. This is less a feature these days than a requirement. While recharge times have gotten shorter and run times longer, it's still comforting to have a second battery. And if you've checked into the price of replacement batteries, you know it's also a valuable feature.

Final Results

Again, we were impressed with almost all the drills' performances, especially with a couple of the consumer drills that could have competed nicely with the professionals. In particular we were impressed with the performance of the Craftsman consumer model (Craftsman is redesigning its professional 12-volt model and it was unavailable for testing at this time), and the Hitachi continues to be a great buy for performance, and

includes a flashlight and a decent bit set.

In the professional category we were impressed and disappointed with some of the performers. We were expecting the Panasonic to do well in the test, but we were surprised how strong a performer it was, earning top marks. Makita, Metabo and Festool all deserve recognition for good performances (though we're still not sold on the very high price of the Festool unit). A little disappointing was the performance of the usual favorites, Porter-Cable and DeWalt. While not knocking our socks off, they did OK. Porter-Cable, however, does get good marks for being significantly less expensive while still providing a quality tool.

So, if you're looking for an inexpensive, reliable, quality drill for your home shop, look to the Craftsman. And if you're looking for a tool to put in your daily-use home shop, or pro shop, look to Panasonic for extraordinary results, or save a few bucks and buy a perfectly capable Porter-Cable at a \$55 savings. **PW**

12-VOLT CORDLESS DRILLS

	STREET PRICE	CHARGE TIME*	SPEED RANGE(S)	AMP/HOUR	CLUTCH SETTINGS	WEIGHT IN LBS	BRAKE	STATED TORQUE	CHUCK SIZE/TYPE	ERGONOMIC RATING	NOTES
CONSUMER											
Black & Decker FSD122K-2	\$80	3 hr	800	1.2	36	3.5	Yes	125 in/lbs	3/8"/2	3.1	LED level
Craftsman 11332	70	3-5 hr	300/1000	1.3	24	4.25	Yes	210	3/8"/2	3.6	Bubble level
Delta CL120	60	3-6 hr	315/1050	1.3	20	4.1	Yes	NA	3/8"/2	3.1	Bubble level
Hitachi DS12DVF	110	1 hr	350/1050	1.4	22	3.4	Yes	195	3/8"/2	3.7	w/flashlight
Ryobi HP1202MK2	60	3 hr	550	1.5	24	3.5	No	NA	3/8"/2	3.6	Bubble level
Skil 2484-04	70	3 hr	350/1450	1.2	6	3.8	Yes	175	3/8"/1	3.8	
PROFESSIONAL											
Bosch 32612	\$130	1 hr	400/1200	1.4	15	4	Yes	280	3/8"/1	4.1	Compact head
DeWalt DW980K-2	170	1 hr*	450/1400/1800	1.7	22	4.9	Yes	350	1/2"/1	3.6	3-speeds
Fein ABS12-EUQ	250	50 min*	340/1200	2	12	4.5	Yes	230	1/2"/2	3	2 battery posit.
Festool TDD 12fx	395	20 min*	380/1100	2	18	4.4	Yes	221	1/2"/1	3.9	Multiple heads
Hitachi DS13DVB	160	50 min	350/1300	2	22	4.2	Yes	200	1/2"/1	3.9	
Makita 6317DWDE	180	1 hr*	400/1300	2.6	16	4.4	Yes	310	1/2"/2	3.7	NiMh batteries
Metabo BST12Plus	170	1 hr*	450/1600	2	20	3.8	Yes	466	1/2"/1	3.7	Impulse feature
Milwaukee 0502-23	160	1 hr*	360/1100	1.4	19	3.8	Yes	220	3/8"/2	3.4	
Panasonic EY6407NQKW	190	55 min*	350/1300	3.5	18	4.4	Yes	293	1/2"/1	4	NiMh batteries
Porter-Cable 9866	135	1 hr*	400/1300	2	20	5	Yes	330	1/2"/1	3.8	

On the 1-5 scale: 1=unacceptable, 5=excellent. Winners are labeled in red. *Indicates smart charger included. Chuck type: 1=single sleeve; 2=double sleeve

CONSUMER MODELS

BLACK & DECKER •

This drill is definitely designed for the occasional around-the-house user, and it isn't really suited for the occasional woodworker. Its performance in the two tests was at the low end of the scale and the drill offers few feature advantages. It's additionally hampered by the single-speed drive when compared to a field of high/low speed competitors. This shortcoming certainly contributed to the performance issues, as with the other single-speed drill tested from Ryobi. The battery charger indicator also was lacking, as with all the consumer models. While in general our staff wasn't in love with any of the slide-off battery packs, the spring loading on this model made it a quick release without fumbling. One interesting feature about this drill is the removable chuck allowing a quick (and compact) change to a hex-shaft tool. An interesting idea, but not enough for a strong recommendation.



CRAFTSMAN •

This drill surprised the heck out of us with its quality performance in both of the tests, out-performing many of the professional models, as well as all the other consumer units. The construction of the drill and the attention to ergonomic comfort are both excellent. As well as the Craftsman performed, it's still lacking a couple of features that would push it into a professional-recommendation category. The two-sleeve chuck is OK, but the rear ring is a little thin and not always easy to grasp. And we still prefer a single-sleeve chuck. As with most of the other consumer models, the charger is of the 3-hour variety, and the battery needs to be removed after charging. At \$70 this is a consumer model that we would comfortably recommend to any occasional woodworker and to many serious woodworkers.



Editor's Choice

DELTA •

Delta is a new player in the cordless drill category, but not in the woodworking field. This drill from the Tennessee-based company is more like the company's benchtop band saws than the Unisaw. It performed adequately in the testing, finishing comfortably in the middle of the pack. At \$60 it's priced to compete well with the other consumer models, but doesn't push beyond the competition. The drill feels big in the hand, but still manages to be fairly well balanced. The battery attachment is slip-on, for less chance of an accidental drop, and the rubber over-molded handle is pretty comfortable. I wish I could say more exciting things about the newest brand name in this category, but honestly it is a decent middle-of-the-road drill – period.



HITACHI •

Priced high for the consumer category, this model from Hitachi came in a comfortable second in testing, putting on a very good show. In addition, this is the only consumer model that comes with a one-hour charger. Hitachi stopped short of offering a smart charger, which would have increased the value of this tool. This is the lightest consumer model tested, well balanced and comfortable to use. When the quality performance and one-hour charger are balanced against the higher price (and what the heck, the included flashlight's nice, too) this is a good-quality tool for the consumer and woodworking market. This model's predecessor dropped some in price after a little while on the market. If history repeats itself, this higher-price consumer drill will become a true bargain.



RYOBI •

This one's a head-scratcher. The poor performance from the Ryobi drill can pretty much be linked to the single-speed motor (similar to the like-handicapped Black & Decker model), but we know that Ryobi can make a very good 12-volt drill. In fact, the Craftsman model that won in this category is made by Techtronic Industries Co. (to Craftsman specifications), which also makes the Ryobi USA drills. This isn't a bad drill, but it really doesn't stack up well against the competition and is more aimed at the very occasional home user. It's hampered even more than the Black & Decker model because it's the only drill in either category that doesn't have a brake to slow the chuck when the trigger is released. Our conclusion is that this model is designed for the folks likely to buy a cordless drill in the check-out line and not worry about performance in the long run. Our apologies to Ryobi, but if you want a better 12-volt cordless drill, spend the extra \$10 and buy the Craftsman.



SKIL •

A decent drill in the consumer category, this Skil finished third in the testing, matching the performance of some of the lower-ranked professional models. Our testers ranked this model the most ergonomically appealing, with good balance, ease of use and a good feel in the hand. This is the only consumer model that has a single-sleeve chuck, offering convenient bit changing. Overall the Skil is a nice drill with decent features.



PROFESSIONAL MODELS

BOSCH • This drill took top honors in the ergonomic category, with a compact, comfortable and well-balanced design. The single-sleeve chuck (originated on Bosch drills a few years ago) is a pleasure to use. The drill also performed competitively in the lag bolt test, but was a real disappointment in the spade bit test. The charger was simple and easy to understand, but we were disappointed that it wasn't a smart charger, requiring extra attention to battery maintenance. The Bosch also comes in at a tie with Milwaukee for the smallest amp/hour battery (1.4, perhaps explaining the spade bit performance) and again ties with the Milwaukee as the only two drills with a $\frac{3}{8}$ " chuck, limiting versatility. Some of the shortcomings of this drill are alleviated by the \$130 price tag, making it a quality affordable option, but falling short of earning Best Value.



DEWALT • This drill made a great first impression with us. It feels solid in your hand, offers decent balance and when you pull the trigger you can feel the torque pull your wrist. But once we got into the testing, we started scratching our heads. This drill performed poorly in the spade bit test and barely made average in the lag bolt test. As the drill offers three speed ranges (a unique feature in this class) we re-ran the spade bit test in both the high-speed mode (as tested with the other drills) and the mid-range mode. The mid-range offered even lower performance. The charger was fairly simple, but it was easy to interpret. This is an adequate drill when used for sporadic, demanding tasks, but for our money, if you're looking for long duration performance, this one falls short.



FEIN • One of the more unique drills in the test, the Fein gives the user the option of having the battery positioned traditionally at the base of the handle, or mounted to the rear of the motor housing. This is pretty handy if you're using the drill to hang drywall on a ceiling! The performance of this model was pretty good, coming in third in the spade bit test, but lagging behind on the lag bolt test. The charger is difficult to understand, and the overall ergonomics were not particularly well rated. We found it rather awkward to remove and replace the battery. While the engineering put into this drill will guarantee its longevity for years to come, its performance and high price make it difficult to recommend it highly. It's our understanding that Fein has a new cordless drill ready to replace this model within the next year or so.



FESTOOL • Another high-priced but unique drill is the Festool model. Offered in both the T-handle version as tested, or a C-handle model that is more compact, the Festool is nearly twice the price of most other competitors. It's also the tool with the most accessories. The replaceable chuck offers you the choice of a right-angle attachment and an offset attachment for working in corners. The drill came in a solid third in the lag bolt test and finished competitively in the spade bit test. Ergonomically it has a good feel, good balance, and is comfortable and easy to use, with one of the easiest battery releases. Though the 20-minute charger is a strong selling point, we found the markings on the charger difficult to understand. While a competent and well-designed drill, its high price keeps us from strongly recommending this tool.



$\frac{1}{4}$ " x $1\frac{1}{2}$ " LAG BOLT TEST

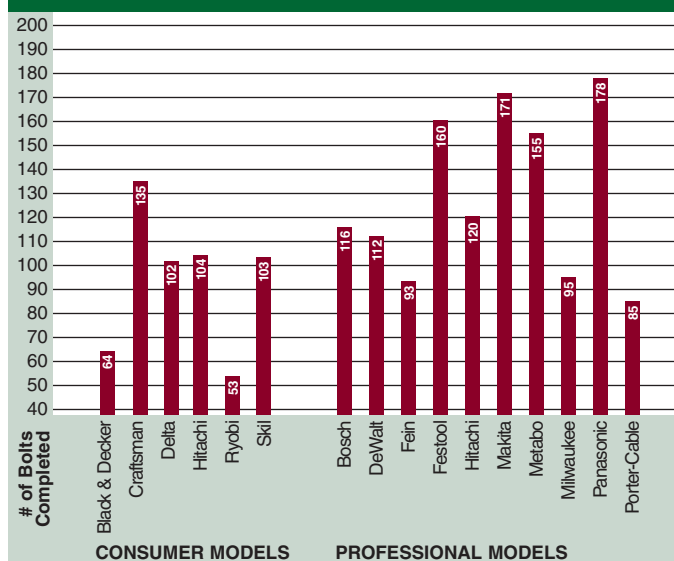

$\frac{1}{2}$ " SPADE BIT HOLES IN $1\frac{1}{2}$ "-THICK POPLAR

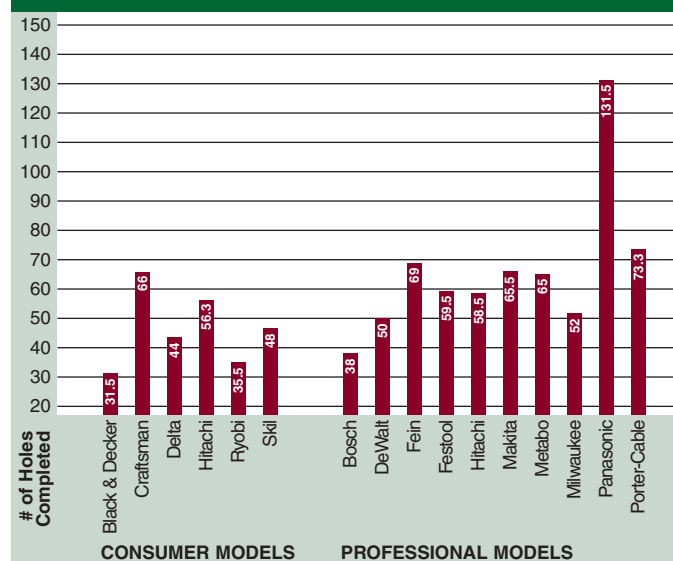

PROFESSIONAL MODELS

HITACHI • This professional-model drill from Hitachi finished competitively in both performance tests, without standing out in either. The ergonomics of the drill placed it in a tie for third, with a comfortable (though slightly large) grip, good weight and balance. The 50-minute charger is a nice addition, with reasonable graphics to inform the user, but it's not a "smart" charger, requiring the battery be removed after charging to maintain peak performance. This makes the charger a pro/con wash in our book. I have nothing bad to say about this drill. It did very nicely in all respects, but there are other drills tested that performed better at similar prices. If you've invested in Hitachi tools previously and would like to continue that trend, you won't be disappointed.



MAKITA • The Makita came in a respectable second in the lag bolt test, performed comparatively well in the spade bit test and placed third in ergonomics. This is a good, all-around drill at a reasonable price. While not outshining its competition, it didn't lag particularly either. It is one of only three professional drills using a two-sleeve chuck, which isn't our preference. The Makita does have a unique feature, which seems odd the first time you use it, but is very smart. Rather than twisting the clutch through all the settings to reach the "screw" position, Makita has added a bypass switch that moves right to screw, leaving the clutch in its last position. We also found the Makita's smart charger easy to use and understand. Overall this is a very good drill, and if it weren't for the Panasonic's huge 3.5 amp/hour battery, we'd recommend it even higher.



METABO • This is a well-made, well performing drill that finished fourth in the lag bolt test and comfortably even with the secondary tier of drills in the spade bit test. Metabo isn't a well-known brand in the United States, but it's well thought of in Europe, and this drill competes well with the better-known brands. In addition to the expected quality features (single-sleeve chuck, smart charger) the BST 12 plus offers an "impulse" feature in the gearing that applies the torque in short rhythmic bursts. This feature directs all the significant break-free torque of this drill to loosening a stuck bolt or screw, or sinking either into tough wood without risking stripping the head. It's a nice feature, without making the price unacceptable. One quirk the drill has is the forward/reverse switch. The Metabo switch operates in the opposite direction of every other drill tested. A good, reliable drill at a reasonable price.



MILWAUKEE For a name that carries as much respect as Milwaukee does, we were a little non-plussed by the performance of this drill, falling below the pack in both main tests. Our testers also found the forward/reverse switch somewhat awkward, and the ergonomics uninspiring. The battery charger is a smart one-hour charger with a single blinking light to inform the user. The battery is a 1.4 amp/hour, making it tied for lowest amp-rating in the pro class. This is also one of only two professional models to offer a 3/8" chuck rather than a 1/2", limiting bit options. The Milwaukee battery does offer an interesting option, allowing the battery to be mounted facing forward or backward, allowing easier maneuvering into tighter spaces. This is an OK drill, but it doesn't compete in this category as well as expected.



PANASONIC • Panasonic knows cordless batteries (see the article on page 70) and that knowledge shines in this very impressive drill. With a 3.5-amp/hour battery smaller in size than most of its competitors' 2-amp/hour batteries (they made the battery cells square rather than round, eliminating the wasted space, duh!), it's no wonder that the Panasonic swept the spade bit test and held a reasonable lead in the lag bolt test. The Panasonic also polled second place in ergonomics, with a solid, compact feel, comfortable grip and good balance. We did question the ratcheting single-sleeve chuck design (rather than a loose, free-spinning chuck) because it seems to encourage tightening the chuck by running the drill with your hand gripping the chuck – not a recommended practice. One other place for improvement is in the labeling on an otherwise very nice charger. We had some confusion as to what the symbols meant. This is a very fine drill at a competitive, professional price and worthy of our Editor's Choice award.



Editor's Choice

PORTER-CABLE • This heavy-duty (and I mean weight) drill pulled off a second place in the spade bit test, but fell back into the lower part of the pack in the lag bolt test. Ergonomically the 9866 finished nearly third even with its status as heaviest drill tested. General use of the drill was adequate, with a charger that allowed easy understanding of the battery status. The drill has a nice single-sleeve chuck, but we weren't as pleased with the battery removal/replacement mechanism. We found the button awkward to work, though the slide-on arrangement reduces concerns of dropping the battery. This is another one of the very competitive drills in the test at a more-than reasonable price. Though it didn't perform at the top of the pack, the \$135 price tag makes this tool very attractive and earns it Best Value recognition in the test.



Best Value

CORDLESS DRILL COLLEGE

While second nature to many woodworkers, there are a lot of things about using a cordless drill that aren't obvious – or even in the manual.

I was using a cordless drill before I had a license to drive a car. I can't honestly remember anyone taking the time to show me the basics; they just told me to go to work. Happily I'm more than willing to pass on some hard-learned lessons about using cordless (and in most cases corded) drills.

An Anatomy Lesson

You don't really need instructions before picking up a drill, but it's not a bad idea to know what to call all those buttons and switches, and to know what they do. So before you take a drive, let's kick the tires first.

The photo at left points out many of the basic features of a cordless drill. Today's cordless drills are almost as capable as corded drills. In fact, most are more feature-laden than corded drills.

You'll find variable-speed control through trigger pressure, and often two and occasionally three speeds. The speed selection controls the maximum speed available, while the trigger pressure varies the speed in that range.

Low speed on corded drills provides slower revolutions per minute (rpm), but transfers the motor power to torque rather than speed. This is the preferable setting for sinking screws or bolts,

and it offers better control and maximum torque. The high-speed setting is the preference for drilling holes (except for when using the largest Forstner bits, when torque and slower rim speed provides the best performance).

Also important on cordless drills is the clutch. This mechanism has six to 32 settings depending on the brand of drill you buy. You set the clutch to disengage the drill when a certain amount of torque resistance is encountered by the drill. This allows you to set your drill to sink a screw to exactly the correct depth without stripping the head off the screw. While some people don't use their clutch because it's a foreign concept, if you try it you'll find there are advantages.

And while we're looking at the front end of the drills, let's talk about the chuck. You'll find two types of toolless chucks (about the only type offered these days on cordless drills). It's either a two-sleeve, or single-sleeve chuck.

With the two-sleeve chuck (generally found on the less expensive models), you insert the bit into the jaws then grab the two parts (sleeves) of the chuck and twist them in opposite directions to tighten the jaws on the shank of your bit.

With a single-sleeve chuck,

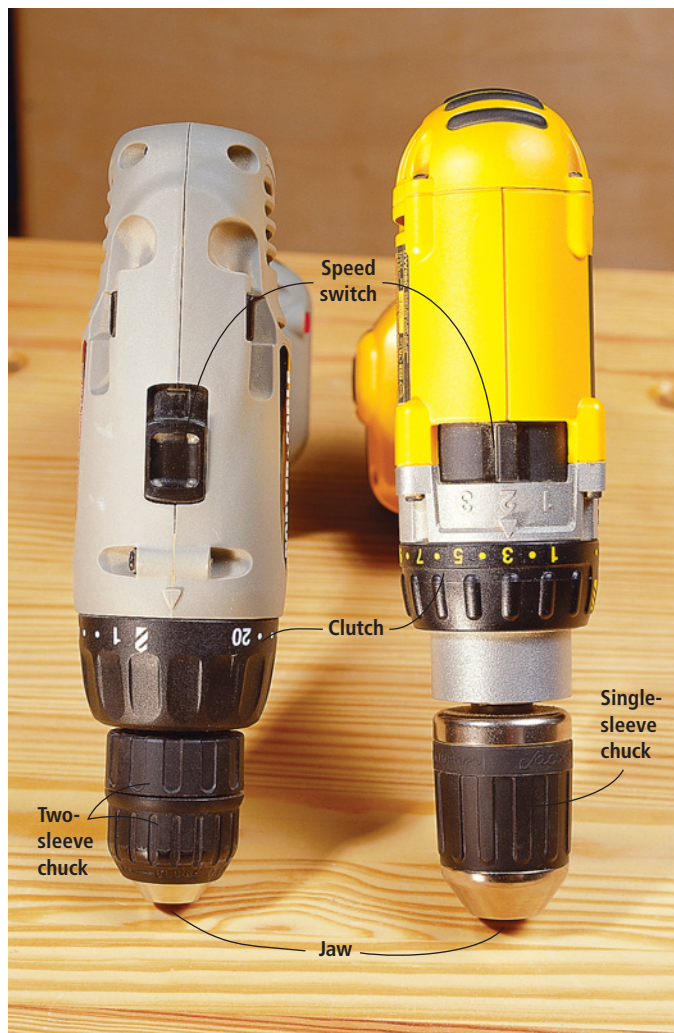

Photos by Al Parrish

by David Thiel

Comments or questions? Contact David at 513-531-2690 ext. 1255 or david.thiel@fwpubs.com.

the drill shaft locks, keeping it from spinning, requiring only one hand to tighten the jaws.

For those of you who are wondering, yes you can grab the chuck in one hand and start the drill to spin the clutch closed. It's not the best practice for the motor, or your hand, but some old tricks are hard to unlearn.

All cordless drills are reversible. They'll run in forward or reverse mode with the flick of a switch, almost always located conveniently behind and above the trigger. Many of the drills also offer a third "neutral" position in the center. This is a good position to store the drill in and to avoid accidentally starting the drill when it's picked up.

Get Charged Up

Now that you know what the switches do, let's make it work. When the drill comes home from the store, you'll find that it has just enough juice in the battery to get about 10 seconds of power. So your first step is to charge the battery completely.

If you've purchased an inex-

pensive drill, it's probably equipped with a charger that will do the job in three hours. Most professional models charge a battery in one hour or even less time.

The first time you charge the battery of your new drill (or if the battery has been completely drained), it can take three to six hours to fully charge, even with the professional models, so don't rush it. Many manufacturers also say that it can take multiple recharging cycles for a battery to reach its peak capacity charge.

In many drills you can charge the battery and safely leave it in the charger. See the photo and accompanying story "All About Batteries."

Ready to Drill

With the battery charged you're almost ready to go to work. Pick your drill bit or screwdriver bit and chuck it in the drill. The more the bit seats all the way to the back of the chuck, the better for holding the bit tight. Tighten the chuck as tightly as you can, making sure the bit is centered in the jaws, and that the jaws are hold-

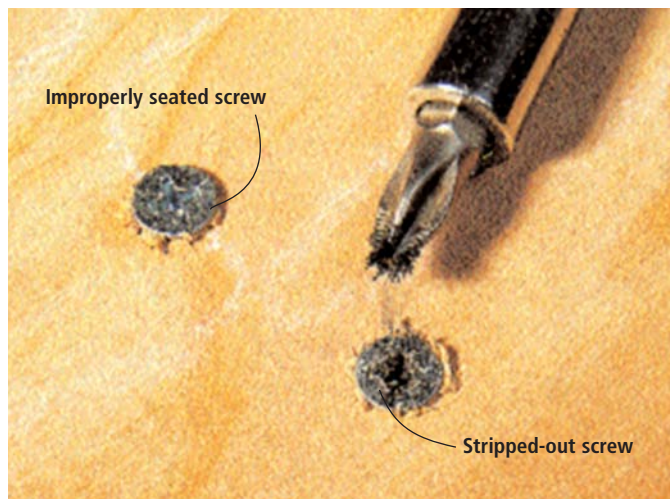

A good example of the benefits of learning to use your drill's clutch is shown above. The screw at left was screwed into a countersunk hole in the wood with the clutch set lightly to protect the head. That worked, but the screw should be flush to the wood, so a stronger clutch setting would be appropriate. The screw at right is a good example of "stripping-out" the head. Even when you're being careful, it's easy to leave the spinning screw tip in contact with the screw after it's seated. Using the clutch on the proper setting will help you avoid stripping-out the screw head.

ing the bit correctly. Some screw-driving attachments are hexagonal in shape with flat surfaces. It's easy to accidentally chuck the bit so the jaws don't grip the flats, which will cause the bit to come loose during operation.

Choose your speed and clutch settings to meet your needs. The next step is gripping the drill correctly. One of the hardest things

to learn in using a cordless drill (or any drill) is to make sure you're drilling or screwing straight. I teach, and use, the pointing method. The picture (below) explains it quickly, but in effect you're using your pointed index finger to direct your tool as it dives into the wood.

There are good reasons for drilling or screwing straight into



KEEPING IT STRAIGHT

"Aiming" a drill is an important and learned skill. When drilling a hole, you may be able to see the angle at which the bit is entering the wood from one axis, but not two. If you shift your view you may be able to confirm the second axis, but that's an awful lot of work for each hole. Instead I use my middle finger as my trigger finger, and use my index finger to "point" along the length of the gear housing. Our body memory allows us to point our finger in the right direction without sighting down our finger, so transfer that memory to the drill.

A second trick shown in this picture is using a strip of masking tape to make a quick depth stop. This is only a quick-fix solution because the tape can slip up the length of the bit if used for too many holes. For a more permanent depth stop, cut a length of dowel and drill through the center. Cut the dowel to length and slip the dowel back on the drill bit, leaving your bit extending past the dowel for whatever depth you need.



Blow-out, when drilling completely through a board, can be annoying and unattractive. It's also easily reduced or eliminated completely by using a backing board. The left-hand hole shows standard blow-out. The right-hand hole was made with the backing board (shown at left) and shows remarkably less damage to the surrounding wood.

your work. Obviously, drilling through the side of a board, or missing the second board altogether and screwing your hand is not a recommended procedure. Also, when putting in a screw, having the screw tip angled to the screw head will strip out the head, making the screw unusable and often leaving it only halfway in the hole. (See the photo on previous page.)



One of the more clever additions to the drill bit category is the piloting/countersinking bit shown at left. Working backwards from right to left, the bit can be used as a pilot bit, combination pilot and countersink, or as a combination pilot and counterbore for use with plugs or buttons. The bit shown here uses a replaceable standard-size drill bit in case of breakage.

Now back to drilling. If you're drilling all the way through a piece of wood, when the bit pushes out the back side of the wood, there's plenty of force pushing on a weak wall of wood fibers, and the last 1/32" of wood ends up being torn through rather than drilled through. Using a backing board (photo at left) will solve this unsightly problem.

Sometimes your workpiece

ALL ABOUT BATTERIES

We had some questions about cordless drill batteries and went to an industry expert, Doug Bock, the group sales manager for Panasonic, for the answers. Panasonic's battery division sells batteries to many manufacturers of cordless drills and is the largest manufacturer of cordless drill batteries in the world.

When you talk about battery performance, think of the amp/hour rating like the gas tank in your car. The larger the tank (and the higher the amp/hours) the longer the drive. It's not a perfect analogy. That doesn't take into account variables in the engine and drive train (motor and gearing) that can affect performance, but it's a quick way to think of things.

Bock explained the difference between NiCad and NiMH batteries simply and in terms of performance. NiMH batteries provide longer run time in the same amount of battery "space." But because of their charging differences they require different care from the charger, making them more expensive. NiCad batteries absorb heat when charging and charge in a flat line with a quick heat spike at the end. NiMH batteries give off heat as they charge (requiring venting) in a gentle climb with a gentle peak at the end of the charge. The difference in heat spikes requires different

charging technology. Early NiMH batteries didn't fare well in NiCad chargers.

Bock also wants to dispel the "memory" rumor you hear about rechargeable batteries. It

was true at one time that if a battery wasn't completely charged the first time it would "remember" that level and recharge only that far. This is old technology and no manufacturer sells batteries with this problem. As to battery maintenance, Bock says to follow the directions. Many batteries will require between three and seven charges to reach maximum capacity. If a battery is left dormant for a month or so (even in a trickle charger) it may not perform up to capacity. By charging the battery for 24 hours (reconditioning the battery) you should get back the full performance of the battery.



One of the more important factors in extending the life of your battery is the charger. A "smart" charger can improve not only the life expectancy, but also the battery readiness. If a battery is charged while too hot (from recent use or just ambient temperature) it may not take a full charge. Smart chargers will check the battery temperature and delay charging automatically until the temperature drops. Also, smart chargers allow the battery to remain safely in the charger once charging is complete without discharging or damaging the battery. In fact the best chargers apply a trickle-charge to keep the battery topped off.

will split in two when the screw is driven. Splitting is a problem when using drills in a fastening application that's solved by pre-drilling a pilot hole. When you're attaching hardware, locate and mark the location where you need to put the screw. By drilling a pilot hole with a drill bit equal in diameter to the screw shank (minus the width of the threads) you'll not only get the screw in exactly the right location, but also keep the screw shank from dramatically pushing the wood fibers apart, splitting the board.

Fastening two pieces of wood with a screw is easier and more successful by using a clearance hole. Similar to pilot-drilling, a clearance hole is a pre-drilled hole slightly larger in diameter than the screw *including* the threads of the screw. The clearance hole is drilled only into the outer piece of wood. This is particularly advantageous when using screws that have threads the entire length of the shaft. If the two pieces move apart slightly during screwing, the threads biting into the first piece will keep it from pulling the two pieces tight. With a clearance hole in the first piece, all the pulling takes place in the secondary piece, making a snug joint.

Another important drilling and screwing topic is countersinking. Flat-head screws are used to keep the screw from protruding above the wood. The tapered part of the screw head can keep the screw from seating flush to the wood. The photo on the previous page shows in detail the benefit of countersinking a screw.

Those are the basics of using a cordless drill. It's important to choose the right cordless drill for your work. If you haven't read through the accompanying drill review, you should take a minute to do so before you go shopping for a cordless drill. **PW**

RIGHT TOOL, RIGHT SPEED

There's a great selection of specialty tips and bits for use in today's corded drills. Just a handful are shown below, (with their general uses listed in detail) offering improved performance for big and small holes, as well as driving and setting screws. To optimize bit performance, the proper speeds are beneficial. While you can't

tell the exact speed the drill is spinning at, you can usually choose a high or low speed. By adjusting your pull on the trigger, you can further refine the variable speed. In short, the larger the bit the slower the optimum performance speed.



Forstner Bit • Best used for drilling holes larger than $\frac{3}{4}$ " in diameter, the Forstner shown uses a saw-toothed rim design, improving cutting speed and reducing rim heat that can damage the cutting edge. Forstners offer clean, shallow holes with good control.

Countersink • When using flat-head screws, the object is to keep the screw head flush, or slightly below the wood surface. While you often can force a flat-head screw to push into softer woods, it's still easier to cut a tapered recess for the screw head. The countersink does this to whatever depth is required.

Spade Bit • This is another option for holes larger than $\frac{3}{4}$ " in diameter. For holes larger than $1\frac{1}{2}$ " you should choose a hole saw or Forstner bit. Spade bits are best used for rough work, leaving more ragged edges in holes and are harder to control. But they are significantly cheaper than Forstner bits.

Hinge Bit • Designed for use in accurately centering a screw in the hinge holes, this bit's sleeve hugs the hole rim, automatically centering the bit, then retracts as the bit is plunged. If you've ever fought with a butt hinge, you know the value of this bit.

Twist Bit • This is the bit most of us think of when "drill bit" is spoken. The tip offers a shallow taper on the cutting edge that is best suited for use in metal work. This bit still appears in lots of woodshops because of its inexpensive nature, but it isn't the best choice for drilling in wood.

Brad-point Bit • The better option in wood is a brad-point bit that uses a center spur to accurately guide the bit as it bites into the wood. This reduces wandering almost entirely, but make sure you start the bit in the correct space, because the spur will guide the bit right where you aim it. A variation on the brad point not shown is a bit with spurs on the outer edge of the bit point as well. These extra spurs provide a cleaner hole, but also give a more aggressive and faster cut.

Magnetic Driver • This accessory should come with every cordless drill. It extends the reach of the drill, allows for a number of different tips (Phillips, square, slotted, Torx, Allen-head) and is magnetized to hang on to the screw. A number of sets now available offer this type of driver with either a quick-change mechanism for pilot and clearance drill bits, or even a two-in-one feature with the bit sleeved inside the driver.

Marble Maze

The perfect project for all the children you know: an ingenious maze created by simply drilling holes at different depths into a block of wood.

Puzzle



Photos by Al Parrish

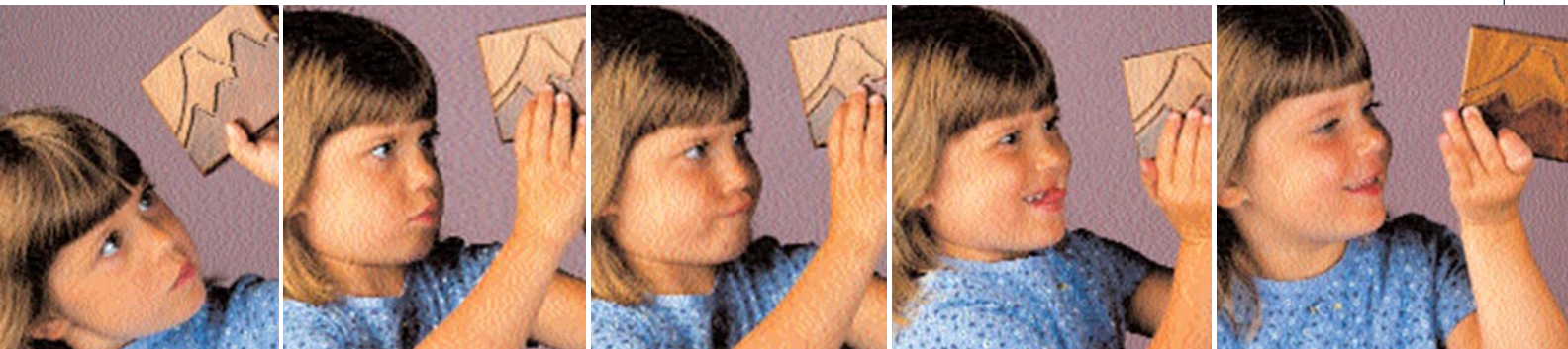

As one of the newest members of the Colorado Woodworkers' Guild, I wanted to build something special for its annual Toys for Tots toy contest. The only problem was that I hadn't yet set up my shop or stocked up on wood, and the guild required six copies of each toy for each entry. Working within those parameters, I came up with this marble maze game.

What makes this ball-in-maze so puzzling is that everything's hidden within the block. You might solve the puzzle several times and never completely figure it out. I don't know what the kids thought of the puzzles, but the big kids (a.k.a. other guild members) couldn't put them down.

Get the Ball Rolling

This isn't a difficult project, but it has a few interesting wrinkles. For those who haven't tried a production run on a woodworking project, this is a good time to learn how cut-off and drilling jigs can help you make multiple projects in the same time it would take to make just one (I made eight in a weekend). Graphically challenged woodworkers (like me) will appreciate how easy it is to make custom images using your computer and a router template guide.

Begin by milling the maze block to size. (I used walnut, but

you can use any straight-grained hardwood.) Because I didn't think that a $\frac{3}{4}$ "-thick block riddled with $\frac{1}{2}$ "-diameter holes would survive in the hands of a 5-year-old, I made my block as thick as my stock would allow, $\frac{7}{8}$ " in this case. As you joint and plane your stock, be sure to make a few extra blocks, in case you make a mistake later on.

After ripping the stock to width on a table saw, cut your blocks to length. If you don't have a stop system on your table saw's miter gauge, make a combination stop block/hold down for your miter saw using a strip of medium density fiberboard (MDF) and a toggle clamp. The stop should be positioned so the blocks are cut to $4\frac{3}{4}$ " long and the toggle clamp

holds the work in place during the cut. Use the miter saw's hold-down clamp to secure the fixture to the miter saw's table.

Make a Mountain Motif

Once the blocks are done, shift your attention to routing a design on the face of the project. Although you might be able to rout it freehand, the template approach is safer and ensures that each box looks as good as the next. You can sketch your own design, find a computerized picture (which

by Joe Hurst-Wajszczuk

Joe Hurst-Wajszczuk is a writer and woodworker. He lives in Denver.

Using a stop block ensures that all the blocks are the same length and prevents the small cutoffs from getting sucked into the saw blade.



Step photos by the author

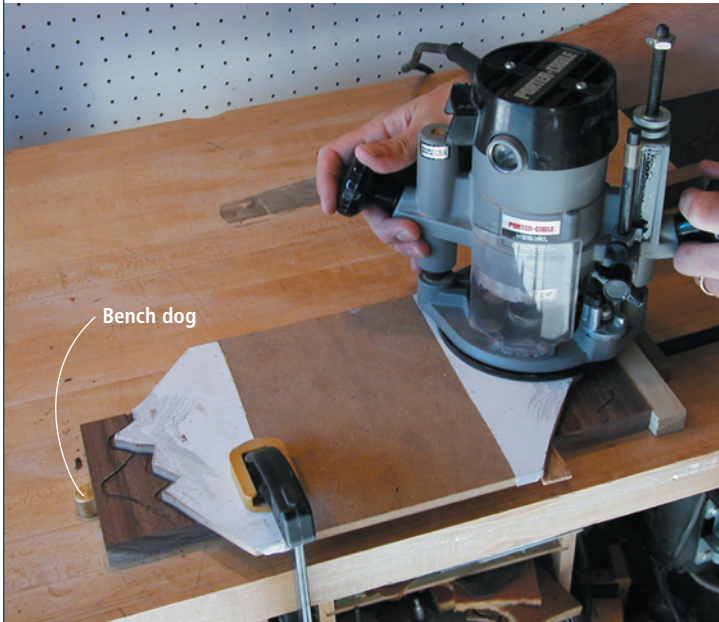

Use double-stick tape and the dogs on your bench to secure the maze block to the routing template.

was what I did) or use the full-size template at right. I chose a design that had a foreground and a background, and it required two templates. Use a spray adhesive to affix the patterns to a $\frac{3}{8}$ " x $8\frac{1}{4}$ " x $14\frac{1}{2}$ " piece of masonite.

Because the mountain motif has a foreground and a background, you'll first decide what you want to be in front. Then use a jigsaw or scrollsaw to cut the outlines on the masonite. Next, place the maze block on the underside of the template and glue stop blocks around the maze block in a "U" shape to capture the maze block. These stop blocks will help accurately position future blocks.

Here's how to clamp your template and work for routing: Put a maze block in place against the stop blocks on the template. Using the dog on your bench vise and a dog in your benchtop, clamp the stop block on the template to the maze block. (You also could use some double-stick tape for additional security.) You are now ready to rout your pattern.

Rout the foreground first. Use

a $\frac{1}{8}$ "-diameter down-cut bit and a guide bushing as shown above. I used the bit and bushing set that came with my router inlay set (available at Woodcraft, 800-535-4486 or woodcraft.com, item #09116, \$38.99).



You'll need a full-size drill press to bore the deepest holes in the maze. The machine's "throw" should be at least $2\frac{3}{4}$ ". Make sure to clamp the block to a fence. If the block moves even a little, the bit might catch and ruin your block. (Remember the extra blocks you cut?) Use a stop block to eliminate errors that come from repetitive measurements.

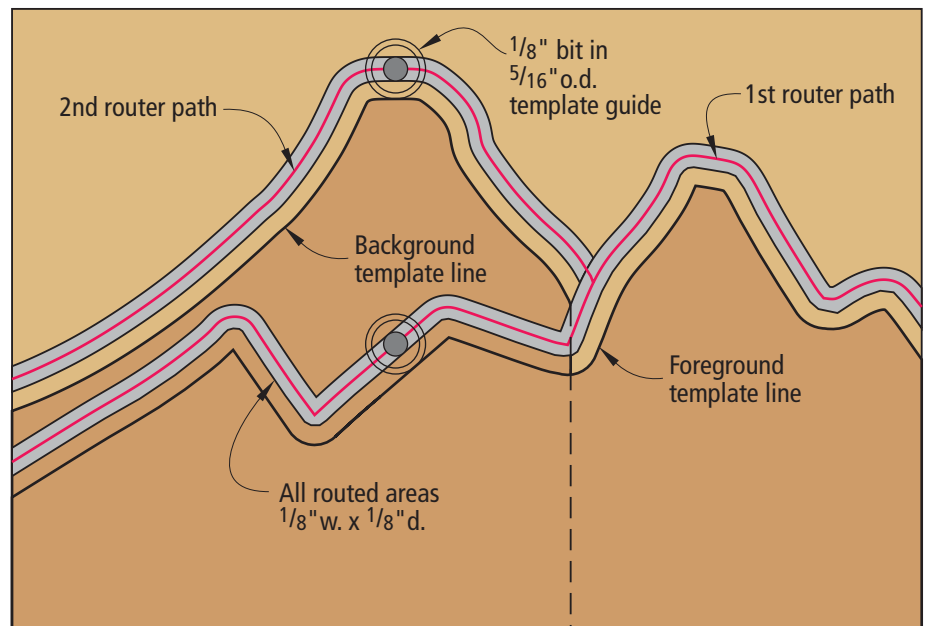

Full-scale face routing templates

To ensure that you follow the template, lightly press the bushing against the masonite at all times. Now flip the template around and repeat this process with the background, but remember to stop routing where the rear mountain intersects with the front range.

Drill a Maze

Now it's time to make the maze. To start, use a marking gauge to scribe a center line on one of your blocks, then carefully lay out the locations for the holes as shown in the diagram. You might also want to use a nail set to dimple the starting point of each hole to prevent the bit from wandering.

To bore the holes, use a drill press and new 1/2"-diameter brad-point bit. You will need to set up a fence system on your drill press and a stop to make this procedure work. It doesn't need to be complicated or expensive. Two pieces of wood screwed into an "L" shape makes a good fence, as shown in the photo at left.

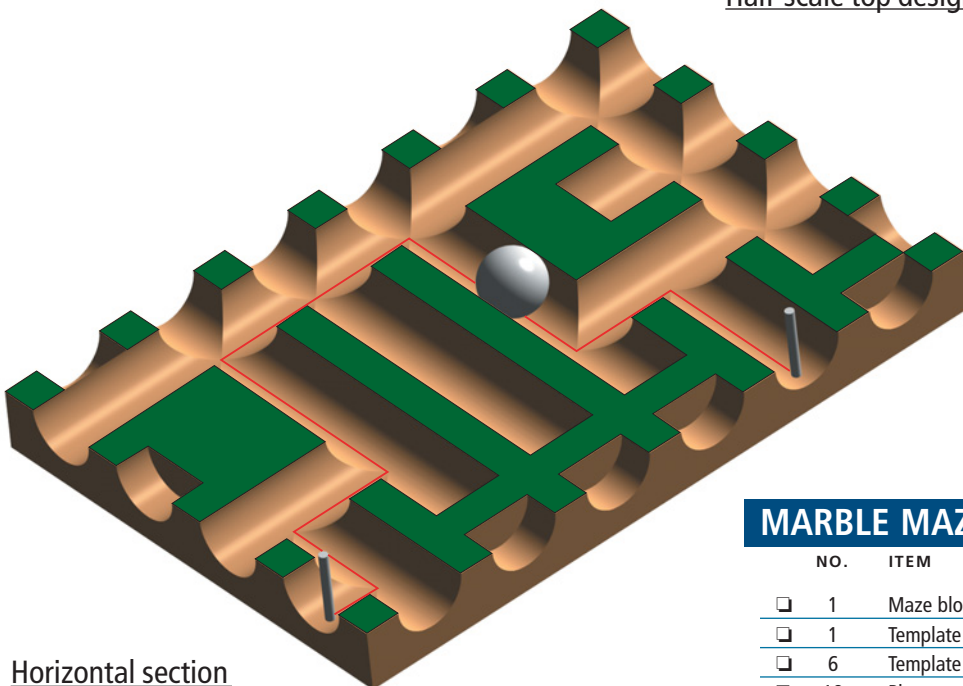
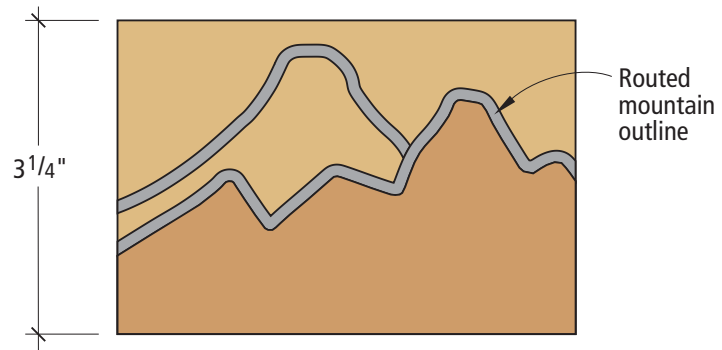
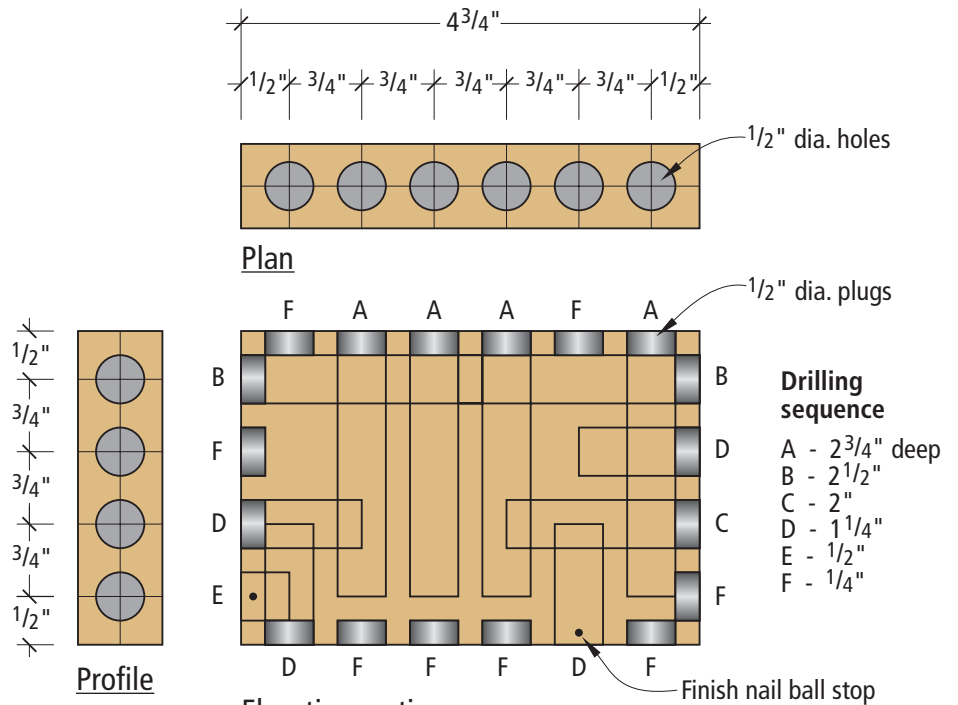

SUPPLIES

One 7/16"-dia. ball bearing available from most home center stores

2 finish nails

MARBLE MAZE PUZZLE

NO.	ITEM	DIMENSIONS (INCHES)			MATERIAL
		T	W	L	
1	Maze block	7/8	3 1/4	4 3/4	Hardwood
1	Template	3/8	8 1/4	14 1/2	Masonite
6	Template stops	3/4	3/4	5	Scrap
18	Plugs	1/2 dia.			Hardwood

Because drilling into existing holes can cause the bit to wander or blow out the grain, start with the deepest holes. First drill the four 2³/₄"-deep holes, then the two 2¹/₂"-deep holes (one from each side), then one 2"-deep hole, four 1¹/₄"-deep holes, then one 1/2"-deep hole and finally, eight 1/4"-deep holes.

Drilling 20 holes per box isn't as time consuming as it might seem – if you use a stop block and drill all the same-depth holes at once. The real trick to success is to make sure that the maze block is correctly oriented against your stop when you make each hole. (If you drill a hole on the oppo-

site end of the block, you may create an impossible maze.)

When drilling the holes, stack all of your blocks to one side of machine so that the mountains are facing you. After each round of holes, make sure the blocks are still correctly oriented before drilling the next hole. When you're done drilling, make sure to shake out all the chips that could clog the maze. If you see any tearout where holes intersect, wrap sandpaper around a dowel to sand the hole smooth.

Plug it Up

The block really isn't a maze until the outside holes are plugged. For

a gap-free look, use a tapered plug cutter as shown below. It's worth noting that even though the plug will only be 1/8" to 3/16" thick, you'll still need to make a full-length plug, because the top of the cutter forms the taper.

After cutting the plugs from a piece of contrasting wood, pop them off with a chisel, then glue them into the maze box. When the glue has dried, trim the plugs with a backsaw, then sand or plane the edges and ends until everything is flush and smooth.

End of the Tunnel

To ease the edges of the maze blocks, you can use a block plane

or sandpaper, but I got the small, tight radius I wanted by using the roundover portion of an ogee bit as shown below. To do this, I made a small router fence from a scrap piece of MDF and positioned it so that only the bottom part of the bit contacted the wood.

Now you can insert the ball bearing and give your maze a test run. To keep the ball in the game, insert finish nails through the backside of the puzzle at the maze's entrance and exit.

To finish the game, sand the boxes to 220 grit, color in one of the ranges with a felt-tip marker to make it stand out, then spray on several coats of lacquer. **PW**



When making tapered plugs, drill until the cutter starts to chamfer the top edge to be sure that you're getting the taper. Drilling through one edge of the plug stock makes it easier on the cutter and allows you to pop off plugs with a chisel.

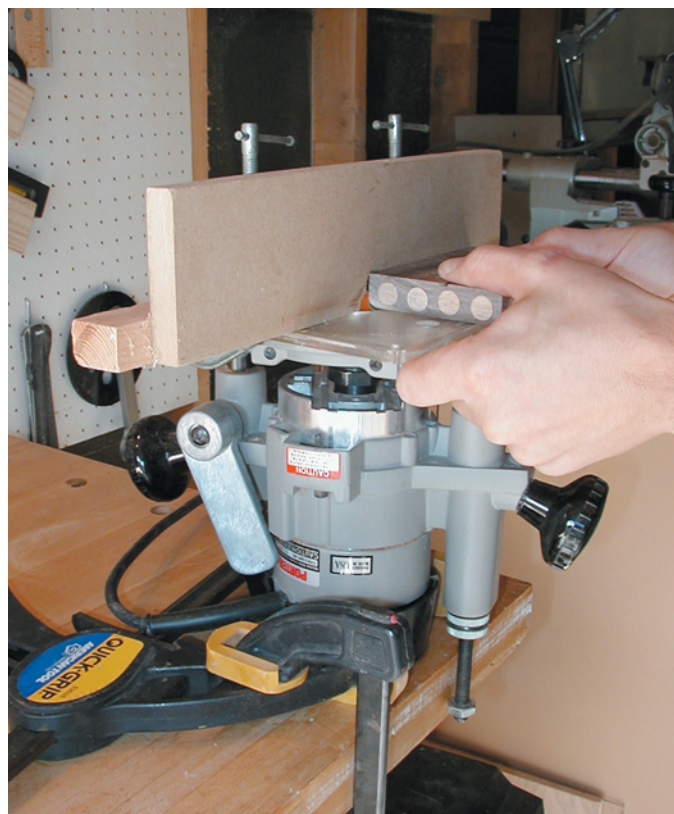

You can make a tiny router table simply by attaching a MDF fence to your router's base. Pivot the fence into the ogee bit until the roundover section pokes through.

SUPERSHOP 10-IN-1 WOOD & METAL SHOP

BECOME A BETTER WOODWORKER - GUARANTEED!

You'll make projects with higher QUALITY, PRECISION, SPEED & SKILL!



SuperShop will increase your woodworking skills or WE'LL BUY IT BACK!



- New, different & BETTER than "look-a-like" machines
- 10 most-used tools in 1 for ultimate versatility
- Rock-solid 450 lbs., 2.5 times MORE than others
- State-of-the-art ELECTRONIC speed controls
- Extra POWER-IN-RESERVE DC motor
- 30-Day RISK FREE Buy-Back Offer & industry-leading Warranty



Get your FREE SUPERSHOP REPORT - "Better Woodworking GUARANTEED!"

CALL TOLL FREE
1-800-476-4849

Or this Mail to: **SuperShop** Dept. PWW, P.O. Box 1517, Ann Arbor, MI 48106

YES! Tell me how SuperShop will increase my craftsmanship. Rush facts, specs, and CURRENT SALE OFFER!

Name _____
Address _____
City _____ State _____ Zip _____

CIRCLE NO. 153 ON FREE INFORMATION CARD.

QUARTERSAWN HARDWOODS & HIGHLY FIGURED LUMBER

Ash, Cherry, Hard Maple, Red Oak, White Oak, Walnut, Sycamore, Mahogany, Hickory, and Birch. Also, many *Exotic Species* in Stock.

NEW We now have Curly Bubinga, Curly Makore & other figured exotics

WEST PENN HARDWOODS, INC.
(888) 636-WOOD (9663)
www.westpennhardwoods.com

Work in shirt-sleeve comfort when it's doggoned cold?

Don't let winter hound you out of your garage. Stay on the trail of your pet projects with a Hot Dawg®.

- Four natural-or-propane-gas sizes to heat from one to five-stall garages, new or old.
- For a free brochure and your nearest Hot Dawg source, fetch your phone and call toll-free **800-700-7324**

www.modine.com

Energy Efficient Garage Heaters



CIRCLE NO. 137 ON FREE INFORMATION CARD.

Save Money—saw your own lumber.



*LT15G15 electric start

LT15G13 Personal Sawmill

\$4995

Make Money—saw for others.

- Cut logs up to 28" D. x 11' L.
- Extra bed sections permit longer lengths.
- Easily transportable.
- Video available.

Prices & specifications subject to change w/o notice.

Wood-Mizer®

Number One in Worldwide Sawmill Sales
www.woodmizer.com

Free Catalog!

8180 W. 10th St. Dept. DF59
Indianapolis, IN 46214

Call for the location nearest you!

1-800-553-0219

CIRCLE NO. 163 ON FREE INFORMATION CARD.

We've Been Busy in Our Workshop, So You Can Be More Productive in Yours!



Grand Rabbet Set, #835.503.11

We never run out of great ideas for router bit sets. Check out our new **Grand Rabbet Set**, or our doormaking

New CMT Router Bit Sets



Junior Panel Set, #800.522.11

bit collections from Marc Sommerfeld and Lonnie Bird. These beautiful boxed sets are always a super gift idea!



Divided Light Set, #800.525.11

New CMT Industrio™ Routing System



New Industrio Routing System #999.500.02

Our router table just keeps getting better! Ask your CMT Distributor for all the new features and details!

New ITK Blades



Manufactured with the finest carbide and steel, these blades set new standards for quality. Ask your dealer about the great values on blade packages!



New Insert Shaper System

With 13 pairs of M2 steel knives and a high-strength aluminum cutterhead, these sets are a terrific value.

Additional knives are available in over 170 profiles!

Get all the details about CMT's exciting new tools, and start having more fun in your shop.



Visit your **CMT Distributor** today!
Call 888-268-2487, or visit www.cmtusa.com

CMT USA, Inc. • 307-F Pomona Drive • Greensboro, NC 27407 • **888-268-2487** • Visit our website at www.cmtusa.com

CIRCLE NO. 110 ON FREE INFORMATION CARD.



If you've every had a chance to inspect an antique armoire, you might have noticed something unusual. Many of these old pieces were designed to be knocked down easily to travel – even the really expensive fancy ones.

In that tradition, this project also knocks down easily, but it uses some high-tech hardware installed with a biscuit joiner.

These plans show you how to build the project as an entertainment center with a shelf large enough to hold two or three video components. The drawers can be fitted with CD, DVD or VCR-tape organizers. The back has a removable panel for easy access to all the electronic components.

However, if you'd prefer a go-anywhere armoire, it's simple work to remove the top shelf and add a hanging rail. It has as much space as a small closet.

For this project I picked ash boards with lots of colors and figured grain patterns for the panels and used the straighter-grained pieces for the rails, stiles and legs. The finish is a clear topcoat.

One more thing: The project is built entirely with biscuits. Even the knockdown hardware and hinges are installed using a biscuit joiner. If this project doesn't convince you of the utility of this tool, nothing will.



Step photos by the author

Make the curve at the feet by first creating a template. Rough-cut the shape using a jigsaw and use a router to make the edges smooth.

Frame First

Create a template of the curve at the base, and use it to trace the pattern onto the legs. The curve begins 6" up each of the six legs and the bottom of each leg ends up 2" wide. Rough-cut the waste material away using a jigsaw. Use your template as a guide to rout the curves smooth.

Now is a good time to cut a 1/2" x 1/2" rabbet on the back legs to hold the back (I waited until after

by Jim Stack

Jim Stack is acquisitions editor for Popular Woodworking Books. He can be reached at 513-531-2690 ext. 1276 or jim.stack@fwpubs.com.

Knockdown

Media Center

This ash armoire, perfect for your wardrobe or entertainment system, can fit into a car's trunk.



Photo by Al Parrish

assembly and made the rabbet using my jointer's rabbeting ledge). Miter one long edge of each of the four front legs. Tape the outside of the joint and apply glue in the miter. Fold the leg assembly together. I made some clamping cauls (as shown in the photo below) to hold the assembly square while the glue sets.

Now set up your router in a router table to cut all the grooves for the panels in this project. I used a 1/4" straight bit that was set to make a 1/2"-deep cut. Cut this stopped groove on the legs, and cut the groove on the long edges of all the rails for the side assemblies. This is the same groove that will be used to assemble the doors, so leave the router set up for now.

Cut the #20 biscuit slots to join the legs and rails. Glue up and finish sand the 1/4"-thick panels before assembling the sides. As always, get all the clamps, glue, biscuits and an assistant (if you need one) together before you start assembling the sides. Be sure to use glue only in the biscuit slots and not in the grooves. You want the panel to float in the grooves so it can expand and contract.

Once the panels are complete, drill the shelf pin holes for the adjustable top shelf.

Knockdown Hardware

With the sides assembled, you now need to prepare the shelves, top and bottom that join them. All of these parts are made from

3/4" plywood with a 1/4"-thick strip of ash on the front edge. The front edge of the sub top is held flush with the front of the face frame, so you'll need to notch the front corners around the front legs.

Now cut the slots for the knockdown hardware. I used Lamello Simplex plates – which consist of two interlocking metal bits that you glue into #20 biscuit slots. You can purchase a box of 100 for \$42 from Lamello's U.S. representative, Colonial Saw (csaw.com or 781-585-4364).

These #20 slots go in the bottom and middle shelves and the sub top. Use a carpenter's square as a guide for cutting the #20 slots

for the knockdown hardware in the sides. The bottom edge of the middle shelf should be located 29 3/4" up from the bottom of the legs. Then cut matching slots in the ends of the bottom, the middle and the sub top.

You need to use a two-part epoxy to glue the aluminum hardware into the slots. I mixed a batch of epoxy about the size of a 50-cent piece (remember those?), which was enough to glue five or six pieces of hardware into the slots. I used toothpicks to put the epoxy into the bottom and halfway up the sides of the slots. Don't use too much epoxy or it will get in the inside of the hook on the



Here is one method that works well for holding the leg assembly square during gluing.



Cove moulding on the table saw is safe if done correctly. It works best if you use a sharp, carbide-tooth blade.

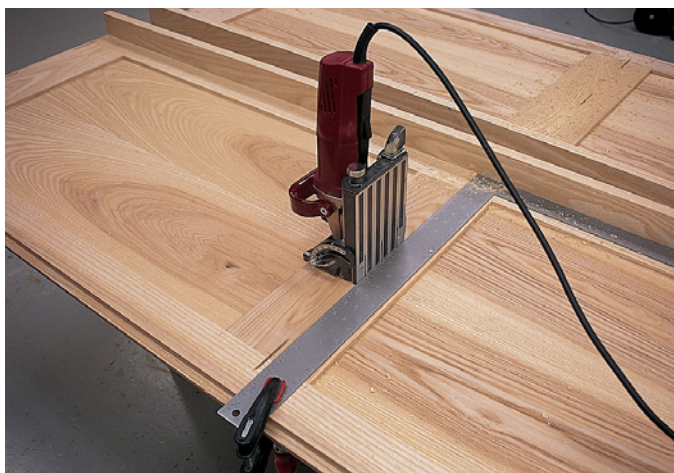

Cut biscuit slots in the ends of the bottom, middle and top shelves for the matching knockdown hardware.



Here you can see the 1/16" lip created by the straight moulding when attached to the inner top panel.

knockdown hardware and on the top sides of the slot. This makes it impossible to put the two parts together after the epoxy has cured. I recommend practicing putting the epoxy into the slots in scrap material before starting.

Once the epoxy has cured, you can knock the case together to see how everything fits.

Top Cap

The top is made up of a few layers. Begin by cutting the inner top panel to size from plywood. You also could make it from $\frac{3}{4}$ " scrap pieces biscuitied together if you're short on plywood.

Miter and nail the straight moulding to the underside of the inner top panel. Let the moulding hang over the panel about $\frac{1}{16}$ ". This lip will make it easier

to align the cove moulding (see the photo below for details).

I made the cove moulding on the table saw. Before you set up for the cove cut, cut a flat face on the moulding material. Set up a fence behind the blade at about a 45° angle to the blade. Clamp it in place and raise the saw blade about $\frac{1}{8}$ ". Test the cut until it is centered in the moulding material and the cove is the proper radius. To center the cut, move the fence toward or away from the blade, keeping the angle the same. To change the radius, change the angle of the fence.

Make your first cut in all the moulding pieces. Raise the blade another $\frac{1}{8}$ " (or a little less if your saw sounds like it's working too hard). Continue until the cove depth is to your liking. You'll prob-

ably need to move the fence slightly toward or away from the blade to keep the cut centered, but try not to change the angle of the fence when you move it.

Miter and nail the cove moulding to the inner top panel by holding it against the lip you created with the straight moulding. Then glue the outer top panel onto the top of the assembled cove moulding.

Insides and Doors

The drawers are made of soft maple with ash fronts. The sides are biscuitied to the drawer fronts, and the back of the drawer is captured between the sides. The bottom slides into a $\frac{1}{4}$ "-wide by $\frac{1}{4}$ "-deep groove in the sides and front.

First make the cutout on the drawer front using a jigsaw and then sand the edge smooth.

These drawers use full-extension hardware, so the drawer fronts need to have a $\frac{7}{16}$ " lip extending past both sides. This lip conceals the hardware when the drawer is closed. Mark the location of the sides on the back of the drawer front and biscuit them in place. Biscuit the sides to the back. Glue and clamp the drawer assemblies.

The drawer slides need to be able to clear the legs, so you have to install spacers at the front and back that you will screw the slides

to. First, lay out on the spacers where the hardware will be mounted on the drawers and transfer this to the cabinet sides. Screw the spacers in place. Attach the slides to your drawer boxes and the spacers, and turn your attention to the doors.

The frame-and-panel doors are built using the same setup as the side panels. Cut the necessary stopped grooves in the stiles and the through-grooves in the rails. Cut biscuit slots to join the rails and stiles. Glue the doors together at the biscuit joints only (allow the panel to float) and clamp.

Finishing Touches

The hinges for this cabinet are installed with the biscuit joiner. They're called Duplex Hinges and can be purchased from Colonial Saw (\$36 for a box of 10 nickel-plated hinges). Fit the doors in the case with the spacings you want and set your biscuit joiner to cut a #20 slot. Center the cutter on that space between the door and leg. Then cut the slot. You'll have a mortise cut into both the door and the cabinet side at the same time. (If you prefer, you also can set the cutter to make the entire mortise in the door instead of both pieces.)

The adjustable shelf needs



Use spacers to hold the hardware parallel to the cabinet bottom. The spacers also ensure the hardware will be located at the same height on both sides of the cabinet.



This is what the door stiles look like before assembly. It's a quick and simple way to make frames (with or without panels).

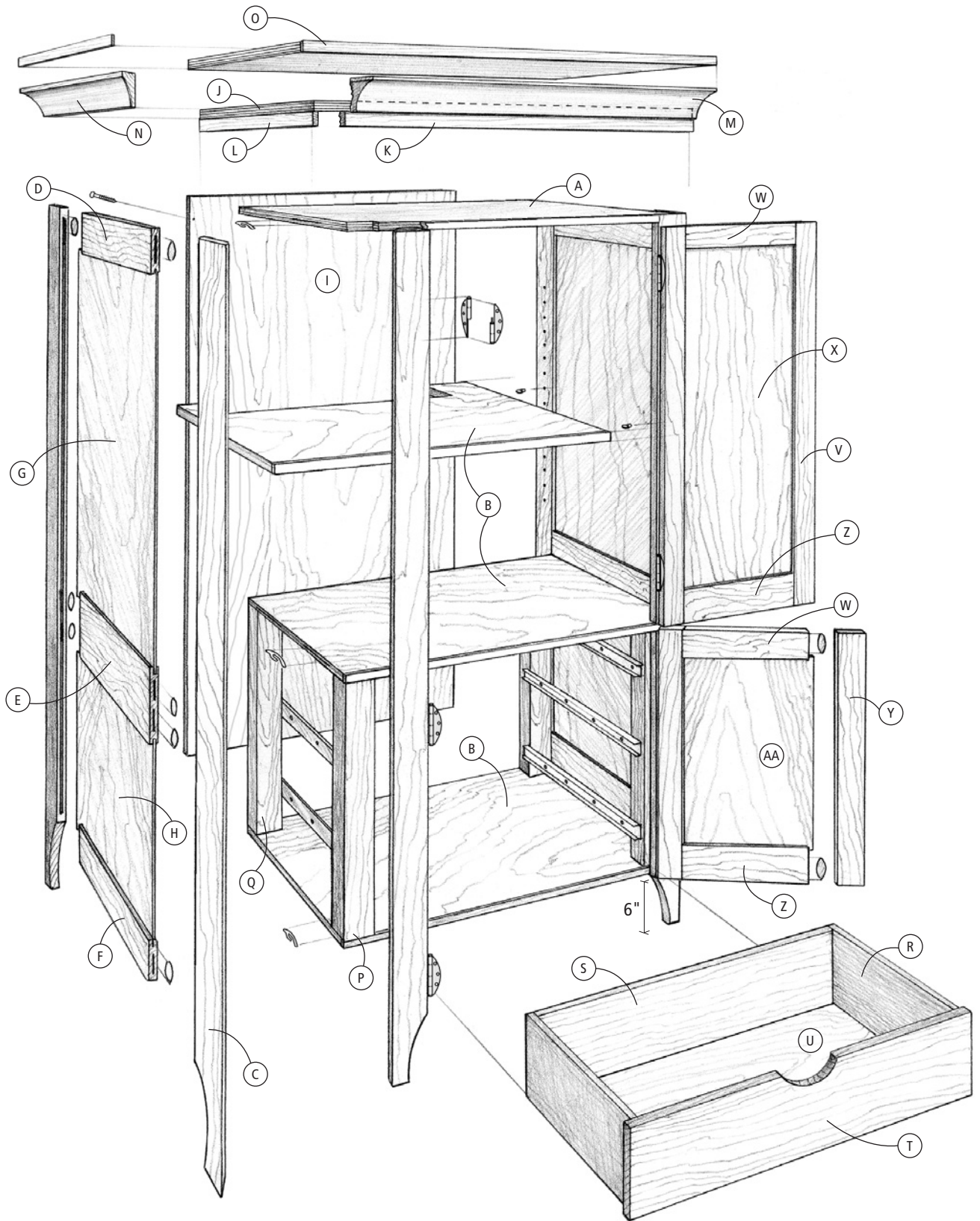

Illustration by Melanie Powell



When mortising the Duplex hinges for the cabinet, add an auxiliary fence to the biscuit joiner because the cabinet face is 3" wide and the fence on your tool probably won't extend that far.

clearance at the back edge for cables and wires. An easy way to create that space is to rip 2" off the back side of the adjustable shelf, then glue two wings to the back of the shelf at both ends. (Use biscuits to hold these wings in place, of course!)

Cut out an opening in the upper part of the back panel for cable and wire access. Then mount the back panel by first adding a frame around the inside edges of the opening to create a 1/2" lip. This essentially creates a shop-made wire grommet.

Cut a panel to fit in the cutout

from the back of the cabinet and attach it with screws. Now screw the back in place on the case.

Use small magnetic catches to hold the doors closed. These are mounted so that both the top and bottom doors use the same magnet; the top door overlays the top half of each magnet, while the bottom door overlays the bottom half of each magnet.

These catches are one of the few things you can't install in this project using your biscuit joiner. But just give the biscuit people some time and I bet they'll come up with a way. **PW**

Excerpted from "The Biscuit Joiner Project Book" copyright © 2002 by Jim Stack. Used with permission of Popular Woodworking Books, an imprint of F&W Publications Inc. Visit your local bookseller or call 800-448-0915 to obtain your copy.

KNOCKDOWN MEDIA CENTER

NO.	LET.	ITEM	DIMENSIONS (INCHES)			MATERIAL	NOTES	
			T	W	L			
Case								
□	1	A	Sub top	3/4	23 1/2	34 1/2	Birch ply	Includes 1/4" x 3/4" ash strip on front
□	3	B	Shelves	3/4	22 3/4	34 1/2	Birch ply	Includes 1/4" x 3/4" ash strip on shelf fronts
□	6	C	Legs	13/16	3	71	Ash	1/4" x 1/2" groove for panels
□	2	D	Top rails	13/16	3 3/4	18	Ash	1/4" x 1/2" groove for panels
□	2	E	Center rails	13/16	5 3/4	18	Ash	1/4" x 1/2" groove for panels
□	2	F	Bottom rails	13/16	3 1/2	18	Ash	1/4" x 1/2" groove for panels
□	2	G	Top panels	1/4	18 3/4	34 1/4	Ash	
□	2	H	Bottom panels	1/4	18 3/4	19 5/8	Ash	
□	1	I	Back	1/2	35 1/2	65	Birch ply	Screwed into 1/2" x 1/2" rabbet in legs
Top Moulding Assembly								
□	1	J	Inner top panel	3/4	24 11/16	37 3/8	Birch ply	
□	1	K	Front straight trim	3/4	1 1/2	37 1/2	Ash	Nailed to underside of inner top panel
□	2	L	Side straight trim	3/4	1 1/2	24 3/4	Ash	Nailed to underside of inner top panel
□	1	M	Front cove trim	1 1/2	1 1/2	40 1/2	Ash	Nailed to front edge of inner top panel
□	2	N	Side cove trim	1 1/2	1 1/2	26 1/4	Ash	Nailed to sides of inner top panel
□	1	O	Outer top panel	3/4	26 1/2	41	Birch ply	Includes 3/8"-thick ash strips on front and sides
Drawers								
□	2	P	Front drawer spacers	2	3 1/2	23	Ash	Allow drawer slides to clear legs
□	2	Q	Rear drawer spacers	1 1/2	3 1/2	23	Soft maple	Allow drawer slides to clear legs
□	6	R	Sides	1/2	7 1/2	20	Soft maple	1/4" x 1/4" groove for drawer bottom
□	3	S	Backs	1/2	6 1/4	25 1/2	Soft maple	
□	3	T	Fronts	3/4	7 1/2	27 3/8	Ash	1/4" x 1/4" groove for drawer bottom
□	3	U	Bottoms	1/4	20 1/4	26	Luan ply	Nail bottom to underside of back
Doors								
□	4	V	Top door stiles	13/16	2 1/4	39 1/4	Ash	1/4" x 1/2" groove for panels
□	4	W	Top rails	13/16	2 1/4	10 3/8	Ash	1/4" x 1/2" groove for panels
□	2	X	Top door panels	1/4	11 1/8	34 1/4	Ash	
□	4	Y	Bottom door stiles	13/16	2 1/4	24 1/8	Ash	1/4" x 1/2" groove for panels
□	4	Z	Bottom rails	13/16	3 1/2	10 3/8	Ash	
□	2	AA	Bottom door panels	1/4	11 1/8	19 3/8	Ash	1/4" x 1/2" groove for panels



Pattern Cutting

on the Table Saw

With a simple two-piece jig, you can use your saw to cut duplicates of large or odd-shaped parts.

Sure, I have a router and a handful of pattern-cutting bits. But many times when I need to make duplicates of an odd-shaped part, I turn to my table saw instead.

With a shamefully simple jig (it's two pieces of wood) clamped to my saw's fence, I can cut patterns all day long. I think it's faster than pattern cutting with my router for several reasons.

First, when roughing out the shape of the blank on my band saw, I don't need to cut real close to my line like I do when pattern routing. I only have to get within $1\frac{1}{2}$ " of the line instead of within $\frac{1}{16}$ " to $\frac{1}{8}$ ".

Second, there's less clamping involved with this table-saw method. Normally I screw or nail my template to the side of the part that won't show (the underside of a shelf, for example) and go. I can do this with pattern routing, too, but I'll still need to clamp everything to my bench, make part of the cut, readjust the clamps and then finish the cut. When I use the table saw, I screw it and cut it.

Build the Jig

The jig should take five minutes to build. It is simply two narrow strips of $\frac{3}{4}$ "-thick wood nailed and glued on one long edge

by Christopher Schwarz

Comments or questions? Contact Chris at 513-531-2690 ext. 1407 or chris.schwarz@fwpubs.com.

(Left) Cutting odd-shaped patterns – such as this shelf for a corner cabinet – is fast and easy with a table saw and a jig made from two pieces of scrap.

(Below) This complex shelf was traced, roughed out and trimmed to size in less than five minutes with only one clamping setup. Try that with your router.



Once your jig is clamped to your fence, you need to align its edge with your sawblade. A square will get you close, but a follow-up test cut or two will get you exactly where you want to be.

into an “L” shape. One of the strips of wood should be as long as your table saw’s fence. Its width depends on how thick your project’s stock is. For cutting patterns in $\frac{3}{4}$ " stock, rip this board to $1\frac{5}{8}$ " wide. The second one should be $1\frac{3}{4}$ " wide and about 6" shorter than the first board. Nail and glue these two boards together using the drawing as a guide.

your sawblade’s teeth. Now wax the edge of the jig to make things slide more easily.

Screw a couple pieces of scrap together and test your setup. When the cut is complete, the two pieces should be perfectly flush. Adjust the fence until this is the case.

Now you’re set. Align the shortest part of the pattern with a jointed or straight-sawn edge. Trace the pattern on your stock using your template as a guide. Rough out its shape using your band saw and then screw the template to your stock. Push the pattern against your jig’s face and slide it forward. Be cautious when sawing short lengths. You’ll probably be surprised how accurate and easy this is, and give your router a rest every once in a while. **PW**

Set Up Your Jig and Use It

Install a quality combination blade in your saw. Clamp the jig to your fence with the jig flush to the table. Slide the table saw’s fence over so the jig overhangs the blade and raise the blade until it almost touches the jig.

Using a square, line up the edge of the jig with the edge of



One of the big advantages to cutting patterns with your table saw is you don’t have to be real accurate when roughing out your stock. With a router, you need to cut pretty close to the line so the tool can handle trimming the last bit of stock flush. With this table saw setup, you have to be within $1\frac{1}{2}$ " of your line – which means you’re much less likely to accidentally cross it, too.

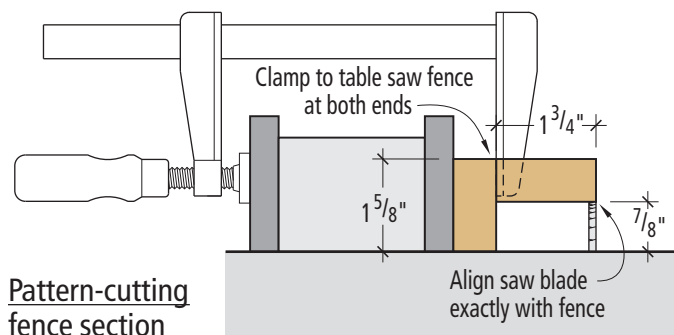

Pattern-cutting fence section

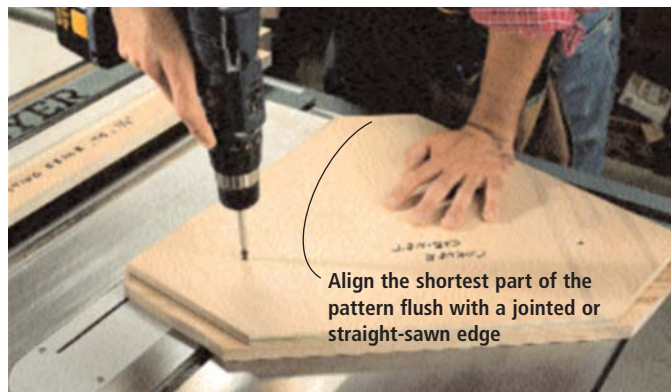

Align the shortest part of the pattern flush with a jointed or straight-sawn edge

For this cherry corner cabinet, I screwed the pattern to the shelf on its sappy underside. A couple brad nails would also do the trick.



Photos by Al Parrish

Simple CD Storage

Build contemporary wall-hung CD racks or wooden inserts for your next home or office project by simply cutting rows and rows of dados.



A CD's slim, compact design allows for all sorts of creativity when it comes to storing them. Tall CD towers and spinning CD cases have flooded the mega-music stores.

Look under any passenger's car seat or flip down any driver's visor and you'll probably find some sort of CD storage device that involves plastic sleeves. And if you've ever built a desk for the home office, you've probably purchased plastic hardware designed to hold and organize your software and music collections.

Last year Senior Editor Christopher Schwarz was building an entertainment center and

wasn't too excited about installing cheesy plastic rails designed to organize CDs into a handsomely built wooden project. Thinking there has to be a better way, he came up with one, opening all sorts of new doors for CD storage. All it takes is a table saw, a dado stack and some creativity.

The concept is simple: Rows of dados specifically sized and spaced to hold the ends of CD cases. You can plow these dados into any piece of wood and then cut the result into all sorts of shapes – creating endless CD-storage possibilities. I liked Chris's idea so I decided to stretch his concept. It worked great.

Cutting the Perfect Dado

Before I even headed into the shop, I collected a bunch of CDs from around the office and began measuring their thicknesses with dial calipers. The thickness of the cases ranged from .393" (a little more than $\frac{1}{4}$ ") to .412" (a little less than $\frac{7}{16}$ "). So I decided to make the first test dado .415" wide.

Next, I headed to the shop. To create a dado exactly .415" wide, I used two $\frac{1}{8}$ " dado blades, an $\frac{1}{8}$ " chipper and two .020" shims. Then, I cut a test dado $\frac{1}{2}$ " deep in a $\frac{3}{4}$ "-thick piece of scrap plywood. Next, I tested the .393"-thick case (the smallest one we found) and the .412"-thick case

This concept lends itself to many different designs. At left is a wall-hung cherry design. The rack above has tapered maple sides and is the perfect size to go on the wall next to your computer.

by Kara Gebhart

Comments or questions? Contact Kara at 513-531-2690 ext. 1348
or kara.gebhart@fwpubs.com.



Use dial calipers to determine the perfect width for your dados. Our dados ended up being .415" (a little less than $\frac{7}{16}$ ").

(the largest one we found) to see how they fit in the dado. To my surprise, the .415"-wide dado was a perfect match. The .412"-thick case slid in and out without any difficulty. And while the .393"-thick case drooped slightly in the dado, it stayed in place just fine.

Next, I tested how much wood I should leave between each dado. Too little wood created too fragile a project while too much wood looked chunky. I concluded that

1" (which includes the width of the dado) worked quite well, and allowed me to work with a simple whole number.

One more important fact: You need to cut dados and not grooves to make this work. Dados are cut across the grain; grooves are cut with the grain. When you cut dados, the CDs won't ever be pinched by the seasonal expansion and contraction of your board. Plus, the end result will be stronger.

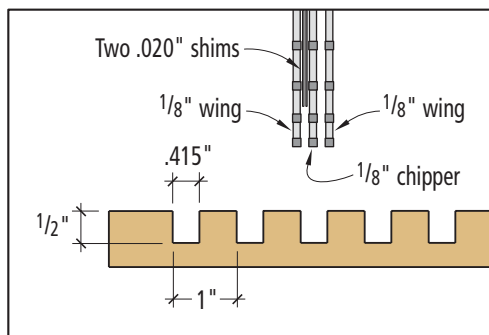

Dado stack setup detail

That's because wood is stronger along the grain than across it.

Rows and Rows of Dados

Before you start cutting your dados, you need to determine the shape of your CD rack. If it's simply going to be an insert inside a cabinet, measure what you need. But if it's going to be a rack hung on your wall, or a case you set on your desk, let your creative juices flow.

I drew up all kinds of sketches ranging from a simple rectangular shape with a contrasting wood frame to more complex shapes that involved angles and curves. Just keep in mind the width of a CD case and the number of CD cases you want the project to hold (one across, two across, three across, etc.). CDs are just a touch less than 5" wide, and you want to allow about $\frac{1}{4}$ " of space on either side so your fingers can get in there. So a CD rack for two columns of CDs should be $10\frac{3}{4}$ " wide. For four columns, make it 21" wide and so on.

Once you have your shape (or shapes) in mind, prepare your stock and glue up any panels you

might need. Make sure your panels are at least $\frac{3}{4}$ " thick ($\frac{7}{8}$ " is better), which will leave room for $\frac{1}{2}$ "-deep dados.

Before you begin cutting dados in your good wood, make a few test cuts in a piece of scrap. Dados $\frac{1}{2}$ " deep and .415" wide worked well for me, but your saw might have some more runout or your shims might be slightly different than mine.

Once you've made your test cuts, decide how much wood you want to leave exposed on the top and bottom of your panels. For this curved wall-hung CD rack, I decided to leave 2" on both the top and bottom.

Now screw a backing board to your slot miter gauge to stop the grain from blowing out at the end of each cut, as shown below. If your stock is narrow, then be sure to clamp a gauge block to your fence as shown in the photo below.

I set the fence at 2" and made the first cut. Be sure to go nice and slow. A little wobble here or there could create a too-big dado causing your CD to fall out of its slot. After you've made your first

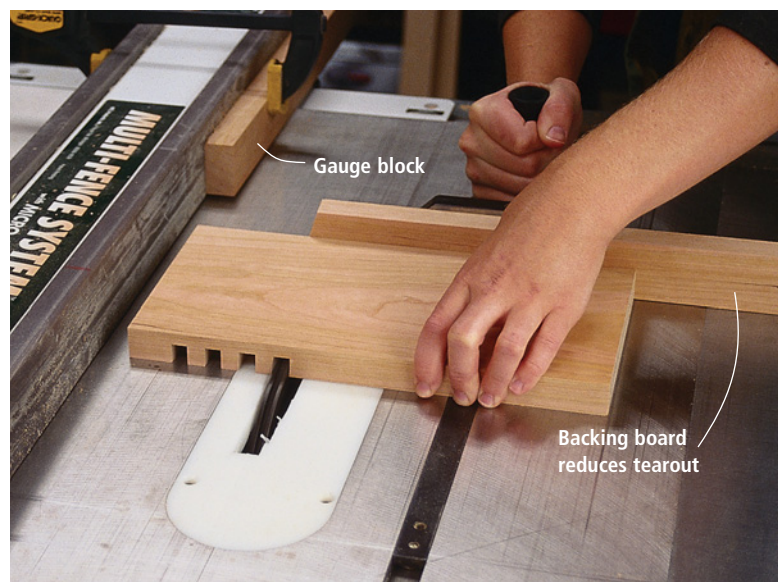

When cutting dados in smaller panels, screw a backer board to your miter gauge. This will decrease blowout.



Cutting rows of dados in larger panels is an easy process. Simply cut one dado, move your fence 1" and then cut the next. Go slow.

cut, move your fence 1". This will leave a bit more than 1/2" of uncut wood between each dado. Make your second cut. Now move your fence another 1". Make your third cut and so on. It's that easy.

Keep cutting dados until you run out of patience or run out of wood. Be sure to leave the same amount of exposed wood on the bottom as you did on the top, depending on your design.

Cutting Your Dados to Shape

Once all your dados are cut, sketch out the shape of your CD rack or, if it's going to be an insert, simply cut it to size. In the photo above you can see a simple way to draw a curve.

Cut out your shapes using a band saw or jigsaw. If you're going

to glue a frame to your rack, cut those pieces and glue them on the edges now. This is the time to be creative.

Now sand everything down. The curves can be a little tricky and might require a spokeshave or a spindle sander to get them looking good. Break all your edges with 150-grit sandpaper. Be forewarned: There are a lot of edges.

Before you apply a finish, you need to think about how you're going to hang your rack. I used a French cleat to hang my curved CD rack, adding a block at the bottom so the rack looks as if it's floating on the wall. You can put two smaller CD racks back-to-back and attach them to a wooden stand to create a simple desktop CD case. Or you can simply



Laying out curves often requires extra brad nails or extra hands. To lay out this curve we marked the center of the panel and then measured 2 1/2" down on either end. We then tapped three nails at each mark. One person held a thin piece of wood at each end nail, while the other person held the wood to the center nail and drew the curve.



Here you can see I'm attaching the French cleat to the back of the curved wall-hung rack. This cleat, along with another block of wood that's attached further down the piece, will make the rack look like it's floating on the wall once hung.

attach a few cabinet hangers to the back of a wall-hung rack. How you hang it is up to you.

A clear finish gives your CD rack a contemporary look, and allows the natural color of what little wood is left to shine through.

While you wait for your fin-

ish to dry, start organizing your CD collection and pick your favorite ones to display. Make sure they're good ones, because with a project this cool they're guaranteed to get noticed. **PW**

SHAPER FENCES AND JIGS

Build your own to increase safety and accuracy.

I still remember the dusty old shaper from my high school woodshop class. It sat quietly in a corner and gathered dust and cobwebs. As students, we were told that it simply was too dangerous to operate.

Years later, when I taught furniture making in a two-year college-level program, I gained a clear understanding of my teacher's trepidation. However, the shaper can be a safe and extremely productive machine.

Yet its simple appearance, a top with a spindle in the center, belies its versatility. The shaper excels at producing simple and complex mouldings, curved mouldings, rabbets and stacks of door panels – all with unmatched power and speed. One of the keys to safely unleashing the full potential of this versatile workhorse is to understand how to set it up with the appropriate fence and/or jig.

I'll often modify the stock fence or even use a shop-made fence of my own design. This allows me to fine-tune the setup to suit the job at hand. Having the best setup produces a smooth, uniform surface that's virtually free of mill marks and tearout (meaning less sanding). But more importantly, using the right jig or fence setup is vital to safe operation.

If you're reading this article, hopefully you already own a router table and have become quite familiar with it. The operating principles of shapers and router tables are very similar, and it's best to gain experience on the smaller of the two machines. And don't trade in your router table. There are many shaping operations it

performs that a shaper can't (see *Popular Woodworking*, August 2002, issue #129).

Light Cuts at First

A key factor in any shaper setup is to limit the amount of stock removed in a single pass. Remember: It's always best to take light cuts, especially if you're new to the machine. Light cuts produce a smoother surface than heavier cuts, so you'll do less sanding afterwards. But more importantly, light cuts are safer because they are less prone to kickback.

So how do you limit the cutting depth? There are two tools of choice: fences and bearings. Fences are used to guide straight stock, and bearings mount on the

spindle along with the cutter to guide curved work. Both are used to limit the cutting depth.

Closing the fence halves and adjusting the fence forward to enclose more of the cutterhead reduces the size of the cut. But when shaping curved stock it's often necessary to remove the shaper's fence and shape against a spindle-mounting bearing. The bearing, positioned above or below the cutter, rolls along a template or the work itself. Using a large-diameter bearing reduces the cutting depth. However, understanding the cutting depth is just the first step to producing working fences and jigs. Next, let's take a closer look at how a fence works as well as a few design options.

Fence it in

The most common setup on a shaper is a straight cut with a fence to guide the workpiece and limit

by Lonnie Bird

Lonnie Bird is the author of "The Complete Illustrated Guide to Shaping Wood" (The Taunton Press) and teaches woodworking. You can learn more about his woodworking classes at lonniebird.com.



The shaper, a powerful woodworking machine, can be made extremely accurate and safe by building some simple fences for routine operations. Here, a panel-raising fence ensures clean results and keeps your fingers away from the cutterhead.

Photos by Al Parrish

the cutting depth. For example, strip mouldings, table edges and raised panels are all shaped with a fence. The fence is clamped to the shaper top and surrounds the cutterhead. An opening in the fence exposes a portion of the cutterhead to shape the workpiece. Decreasing the fence opening to the smallest possible size gives the greatest support to the stock and limits the possibility of kickback. Beyond simply adjusting the fence halves on your shaper, there are several other effective methods for reducing the fence opening to increase the safety and accuracy of the setup.

Zero-clearance Fence

A zero-clearance fence is just as the name implies – there’s no opening in the fence beyond the profile of the cutterhead. A zero-clearance fence gives the maximum support to the workpiece.

The easiest way to create such a fence is to use the cutterhead to shape the opening. Begin by fastening a plank or strip of thick plywood to the shaper fence. Next, turn on the shaper, slightly loosen one of the nuts that secures the fence (leaving the other side locked in place) and slowly pivot the fence into the spinning cutterhead. Now secure the fence and make the cut. You’ll get maximum stock support and minimal

tearout. Snipe also will be eliminated because there’s no problem with misaligned fence halves. But don’t try this technique with anything but small-diameter cutterheads; pivoting the fence into a large, spinning cutterhead can cause it to grab violently. So let’s take a look at some other options.

Build a Custom Fence

For cuts I make frequently, I build a custom fence to fit the cutterhead. A custom-built fence saves considerable setup time because it is always ready to use. And the fence fits the cutterhead like a tailor-made suit; the opening is tight to give maximum support to the workpiece.

For example, because I often build furniture casework with lipped drawers, I have a shaper fence specifically for rabbeting drawer fronts. After the ends and top edge of the drawer front are rabbeted, I cut dovetails in the rabbet. So the rabbet must be smooth and precise.

My custom fence, coupled with a square cutterhead, cuts a clean, uniform recess ready for dovetailing. The fence is really a thick plank of maple with an oval recess cut into the bottom in which the cutterhead spins. A small, zero-clearance opening in the edge of the plank exposes a small portion of the cutterhead – just



Cutting a lip on the backside of a drawer front is a common shaper operation (above). With this simple fence, the entire drawer front is in contact with the fence throughout the cut, and there’s little opportunity for tearout. Lipped drawers are commonly used in conjunction with half-blind dovetails.



Making a zero-clearance opening for your cutter improves your cut in three ways: it reduces tearout, it gives maximum support to the workpiece so it won’t tip into the cutter and it eliminates any chance of snipe that occurs when you have the two halves of the shaper’s fence out of alignment.

enough to shape the rabbet. Best of all, the uncut portion of the workpiece above the rabbet is supported by the fence above the cutterhead. So the work is in contact with the fence throughout the cut and there’s no fence opening to catch a corner of the work and spoil the cut. Also, because the fence fits the cutterhead, it’s always ready for action. I simply clamp it to the top of the shaper and go. There are no time-consuming adjustments or modifications to be made as with the stock shaper fence.

Box it in

Let’s face it: Large-diameter cutterheads are scary. Just the sound of a panel-raising cutterhead whizzing at 7,000 rpm is intimidating. What’s worse is the huge opening in the stock shaper fence to accommodate these cutter-

heads. Large fence openings are an invitation for kickback because the workpiece can tip into the cutterhead. A large fence opening also exposes more of the spinning cutterhead to your hands. Remember this simple rule: Reduce the size of the fence opening and you’ll reduce the level of risk. It’s as simple as that.

Years ago I developed a box fence for raising panels that completely encloses the cutterhead. The panel slips underneath the front edge of the box for shaping; the box front adjusts vertically to accommodate different panel thicknesses. Best of all, the fence opening is very small, which virtually eliminates the possibility of kickback. It works like this:

The fence also serves as the base of the box. Made of 1/4" plywood, it guides the panel edge as the workpiece is fed through the

machine. Because the cutterhead is positioned over the fence opening, the opening only has to be wide enough to accommodate the shaper spindle, about 1". This small opening allows maximum support to the workpiece throughout the entire cut.

Use a Tall Fence for Wide Stock

Shaping the face of wide stock presents another challenge. The narrow edge of the board provides little support for the stock as it's fed through the machine. The solution is to fasten a tall, auxiliary fence to the machine. To make a tall fence, I fasten a wide strip of 3/4" plywood to the stock



Shaping mullions and muntins on a shaper (or even a router table) can be intimidating. This jig has a notch in the edge that holds your work down and against the fence.

fence with several screws. The plywood provides a smooth, flat surface to guide beaded backboards and other wide stock past

the cutterhead. Featherboards are also helpful to maintain pressure against the stock and fence.

Jigs for Small Stock

Small stock can pose a hazard with any woodworking machine, and the shaper is no exception. Narrow, thin or short pieces are prone to kickback and can be difficult to grasp safely. The easiest solution is to shape an oversized workpiece and mill it to final size after shaping.

Although a great technique, this one-size-fits-all solution doesn't work in every situation. One example is the narrow mullions for a divided-light door. To safely shape the moulded edge and rabbet along the length of these diminutive strips, I use a jig that

adds mass and positions my hands at a safe distance from the action. The workpiece slips into an "L"-shaped notch along one edge of the jig. The thin plywood "cap" places downward pressure on the work during the pass.

Another easy solution for grasping small stock is to clamp the work in the jaws of a large wooden handscrew; the clamp will add mass and give you a safe position for your hands. And remember, whenever you're shaping small stock, it's critical to adjust the fence opening as small as possible.

Templates for Curved Work

Curved, sensuous legs, tabletops and mouldings can add tremendous visual appeal to a furniture design – they also present special challenges for shaping. Although it is sometimes useful to construct a curved fence, this method is usually impractical because the curved workpiece is irregular rather than an arc. Often, the best solution for shaping a curve is to use a template.

Templates perform many of the same functions as a fence; they guide the work and limit the cutting depth. But templates also let you safely and effectively shape curved parts such as elliptical tabletops and flowing chair legs.

Here's how it works: A bear-

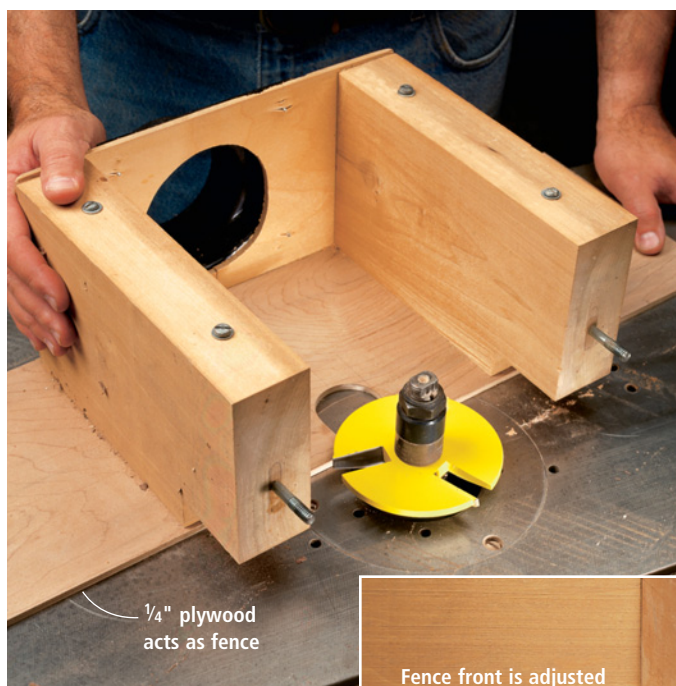

1/4" plywood acts as fence

This accessory fence for raising panels gives you maximum support to your workpiece thanks to the 1/4" plywood that surrounds most of the spindle (above). The front of the fence bolts on and can be adjusted up and down to accommodate different thicknesses. The front of the fence also keeps your work flat to the table during the cut (right).

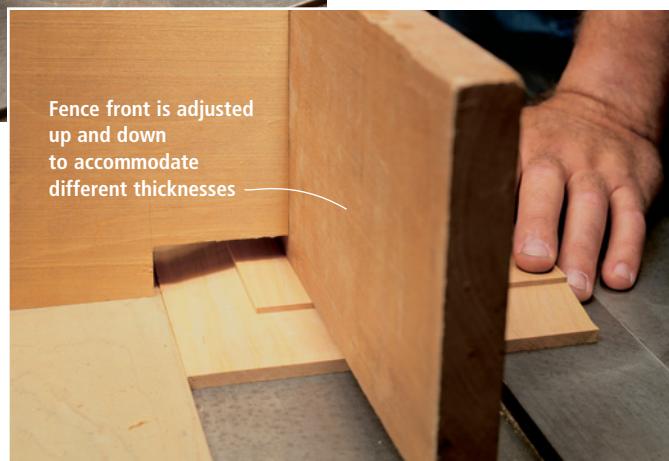

Fence front is adjusted up and down to accommodate different thicknesses

ing is mounted on the shaper spindle above or below the cutterhead. The workpiece is fastened to the template, which follows the bearing to produce the shape. If you've ever used a router and bearing-guided bit, then I'm sure that you understand this principle. However, as with most shaper techniques, it's on a larger scale.

So remember: Reduce the size of the cut and you'll increase the margin of safety. When shaping with templates, you can decrease the cutting depth by using a large-diameter bearing.

I shape curved stock in several passes by reducing the bearing size after each cut. There are other safety considerations, too. First, when constructing a template, always extend it several inches beyond the workpiece. This way the template will contact the bearing before the work comes in contact with the cut-

terhead. This makes the start of the cut smooth and virtually eliminates the risk of kickback.

Also, make certain that the work is locked securely in the template before you begin. Although toggle clamps are effective, I usually go a step further and use a few strategically positioned screws to further secure the work in the template. Just remember to place the screws well out of the path of the cutterhead.

Finally, whenever you use the shaper it's critical to position your hands a minimum of 6" from the cutterhead. Template shaping is no exception. In fact, it's best to provide hand holds for a secure grip and maneuverability of the template. I typically use plastic push blocks for this purpose and fasten them to the template base with screws. **PW**



When shaping curved stock, your best bet is to create a template that can guide your work and keep your hands away from the cutterhead. A bearing below the cutter rides along the edge of the template, guiding the cut.

SAFETY GUIDELINES FOR SHAPERS

- Keep the cut small. Several small, light cuts are much safer than one large cut.
- Make the fence openings as small as possible. This reduces the risk of the work dropping between fence halves.
- Fasten the fence securely to the shaper top. Large C-clamps work well. If you're running the shaper for extended periods, check the clamps periodically.
- Position your hands at least 6" from the cutterhead. Remember, this is the minimum distance; large cutterheads require more. Use pushblocks, jigs and pushsticks.
- Always use guards. If necessary, devise one of your own.
- Always follow manufacturers' guidelines for both the shaper and the cutterheads.
- Always feed the workpiece against the rotation of the cutterhead. If your shaper has a reversing switch, make certain of the rotation of the cutterhead before you begin.
- Select the appropriate spindle speed. Large-diameter cutterheads,

such as those designed for panel-raising, have a higher rim speed than small-diameter cutterheads and should be run at a lower rpm.

- Position the cutterhead so that it cuts from underneath the workpiece. Using this method, the workpiece acts as a barrier, and any portion of the cutter not being used will be safely positioned below the table surface.



Use featherboards (or the spring holddowns that come with your machine) whenever possible. These reduce vibration and chatter on your work, preventing kickbacks.

- Avoid shaping short, thin or narrow stock. Instead, shape an oversize piece of stock, and then size it to the dimensions needed after shaping; or construct a jig to hold it securely and position your hands at a safe distance.

- Use spring holddowns and featherboards whenever possible. These simple devices aid in keeping the stock against the table and fence, reducing vibration and helping to keep the workpiece flowing in the intended path.
- Always use a starting pin when shaping freehand. The starting pin works as a fulcrum to allow you to safely pivot curved work into the spinning cutterhead and against the guide bearing.
- When shaping with a template, extend the template beyond the workpiece. This way, the template will contact the guide bearing before the workpiece contacts the spinning cutterhead.
- Disconnect the shaper from its power source before making any setups or adjustments.



Forrest Saw Blades

America's Best Since 1946!

"You Can Count On Us For Quality, Performance, and Dependability!"

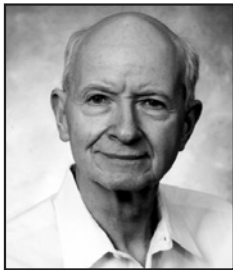

Jim Forrest, President

"For almost 60 years, our company has manufactured top-quality saw blades that eliminate or reduce splintering, scratching and tearouts, and we've offered the finest in-factory sharpening available anywhere. We use only high corrosion-resistant C-4 carbide for extended use between sharpenings. And now all Woodworker I and II blades 10" or larger have 30% more carbide than before...for the longest possible blade life.

"Here's our no risk-guarantee: Purchase any Forrest blade or dado and use it for up to 30 days. If you are not completely satisfied for any reason, return it for a full refund. You have my word on it!"

New Discounts!
Save 10% on one (1) blade or dado!
Save 14% on multi-blade/dado orders!

Woodworker II

ALL PURPOSE – table saws and portable circular saws.

	Size	Price
The 10"x40T is the only blade rated "excellent" for both rip and cross cuts by <i>Fine Woodworking Magazine</i> (March/April, 2002).	12" x 40T x 1"	\$131
	10" x 40T (1/8" or 3/32" K)	\$121
	10" x 30T	(1/8" or 3/32" K) \$101
	8 1/4" x 40T	(3/32" K)* \$101
	8" x 40T	(3/32" K) \$101
	7 1/4" x 30T	(3/32" K) \$ 71
	5 3/8"x40Tx10mm (5/64" K)**	\$ 83

Also available: 14"x40Tx1" • 14"x30Tx1" • 12"x30Tx1" • 16"x40T • 9"x40T • 16"x30T • 9"x30T • 8"x30T(3/32"K) • 6"x40T(3/32"K). Call for prices.

*For Sears & Makita **For DeWalt Cordless Portables

Now with 30% more carbide!



Fine Woodworking EXCELLENT

Customized Woodworker II

For the advanced table saw operator. Ideal for joinery and special uses!

Size		Price
10" x 40T (1/8" K)	#1 grind for square cut box joints.	\$132
10" x 40T (1/8" K)	#6 grind for near flat bottom, easy feed.	\$132
10" x 40T (1/8" K)	Dovetail joint grind. Specify angle & left or right points. See Fine WW12/01.	\$132
10" x 40T (5/64" K)	Ultra thin kerf for precision work. Use stiffener plate.	\$141
10" x 20T (1/8" K)	Fast feed rip for thick hardwood without burning.	\$ 71

Now with 30% more carbide!



Dado-King

You get flat-bottomed grooves and no splintering—even when crosscutting oak plys and melamine. This award-winning set comes with six 4-tooth chippers (including 3/32" chipper), two 24-tooth outside blades plus shims. Cuts 1/8" to 29/32" grooves.

Size	Price
6" set	\$271
8" set	\$291
10" set	\$349
12" set	\$449

FREE \$21 value! 10" Blade Runner carrying case. Protects and holds up to 10 blades. Ships with 6", 8", or 10" Dado sets. Included free with your order!



AMERICAN EDITORS' CHOICE WOODWORKER

Chop Master

Specially designed for sliding compound miter, miter-chop, and radial saws.

Size		Price
7 1/2" x 60T x 5/8"	Makita Cordless Slide	\$101
8 1/2" x 60T x 5/8"	Hitachi, DeWalt, Ryobi, Freud TR125	\$121
10" x 80T x 5/8"	Delta, Bosch, Hitachi, Makita, Ryobi, AEG & all	\$141
12" x 80T x 1"	Delta, Hitachi, Makita, B&D, Sears & all	\$151
15" x 100T x 1"	Makita, Ryobi	\$199

Also available: 8 1/4" x 60T • 6 1/2" x 40T • 9" x 80T • 14" x 100T. Call for prices.



NEW!

Duraline HI A/T

Cuts melamine perfectly. 220mm & 300mm available. Our best plywood blade.

Size	Price
10" x 80T (1/8" or 3/32" K)	\$161
12" x 80T x 1" (1/8" K)	\$181

Also available: 14"x100Tx1" • 14"x80Tx1" • 16"x100Tx1" • 8" • 7 1/4" and others. Call for prices.



Woodworker I

Designed for radial arm or tablesaws—fine crosscut.

Size	Price
7 1/4", 8", 8 1/4" x 60T	\$111
10" x 60T	\$131
12" x 60T	\$141

Also available: 9" x 60T • 14" x 60T • 16" x 60T. Call for prices.

Now with 30% more carbide!



Two Easy Ways to Order

Call toll-free

1-800-733-7111 OR stores.yahoo.com/forrestman

(In NJ, 973-473-5236)

Fax 973-471-3333

Se habla español

Western Canada: Call Sharp Tech, Inc.

877-228-0908 • Fax 403-225-3767

Other Canadian Sales: Call CMR - Ron Collier

800-229-4814 • Fax 989-684-0402

Visit our internet store



DON'T SEE WHAT YOU NEED?
Call us for other blades and dampener discs!

\$15 OFF* OUR EXPERT BLADE SHARPENING!

Don't take a chance with micro-chipped edges on your expensive wood! Our in-factory sharpening preserves the life and performance of all types of carbide blades. In fact, Forrest Manufacturing represents the industry standard for fine quality sharpening. Most orders processed in 3 to 5 days. You'll receive \$15 in DISCOUNT COUPONS* for our expert factory sharpening with every new Forrest blade or dado you purchase! Coupons can be used to sharpen any carbide blade. (Please include return UPS of \$7 + \$1 for each additional blade.)

FREE SHIPPING—
All Orders Over \$275
Other orders, please add:
Saw blade — \$7 • Dado — \$9 • Stiffener — \$3

FORREST Forrest Manufacturing Company
457 River Road
Clifton, NJ 07014

* 3 coupons at \$5 each, use 1 coupon per blade.

© 2002 Forrest Manufacturing Company, Inc.

PRODUCT INDEX

	PAGE #	CIRCLE #	WEB ADDRESS
ADHESIVES			
Gorilla Glue	18	120	gorillagluce.com
Polymeric Systems	102	144	epoxysticks.com
BITS, BLADES & CUTTERS			
Amana	8	101	amanatool.com
CMT	77	110	cmtusa.com
Forrest Mfg.	95	119	stores.yahoo.com/forrestman
Hickory	21	123	oldham-usa.com
Librawood	102	132	librawood.com
MLCS	35	136	mlcswoodworking.com
PS Wood	20	145	pswood.com
Ridge Carbide	102	146	ridgecarbide.com
Routerbits.com	102	149	routerbits.com
Viper	19	158	oldham-usa.com
Woodline USA	14	166	woodbits.com
BOOKS			
Woodworker's Book Club	Insert	—	woodworkersbookclub.com
Woodworker's Supply	99	172	woodworker.com
BUILDINGS & WORKSHOPS			
Heritage Building Systems	103	—	heritagebuilding.com
U.S. Buildings	102	157	us-buildings.com
FASTENERS			
McFeely's	34	135	mcfeelys.com
FURNITURE & PROJECT PARTS			
Adams Wood Products	34	100	adamswoodproducts.com
Classic Designs	37	109	tablelegs.com
DCT Holdings	102	114	dctleathers.com
Osborne Wood Products	97	142	osbornewood.com
HAND TOOLS			
David Warren Direct	102	—	ecemmerich.com
Lee Valley/Veritas	24	131	leevalley.com
Lee Valley/Veritas	31	130	leevalley.com
Lie-Nielsen Toolworks	28	133	lie-nielsen.com
HARDWARE			
Whitechapel Ltd.	28	160	whitechapel-ltd.com
KITS & PLANS			
Bunk Beds	103	108	—
Murray Clock	103	138	murrayclock.com
Shortridge Co.	102	152	shorridgelt.com
U-bild.com	102	156	u-bild.com
Woodcraft Plans.com	102	165	woodcraftplans.com
Woodprojects.com	102	169	woodprojects.com
MISCELLANEOUS			
Dakota Alert	102	113	dakotaalert.com
POWER TOOL ACCESSORIES			
Beall Tool	102	104	bealltool.com
Bench Dog Tools	8	105	benchdog.com
Excalibur by Sommerville	33	117	excalibur-tools.com
Jointech	34	128	jointech.com
Leigh	20, 26	—	leighjigs.com
Woodpeckers	15	167	woodpeck.com
Woodpeckers	28	168	woodpeck.com
POWER TOOLS			
Ashman Technical	34	103	woodworktools.com
Bosch	2	107	boschtools.com
Delta Machinery	12	115	deltamachinery.com
Delta Machinery	13	116	deltamachinery.com
Fein Power Tools	27	118	feinusa.com
Grizzly Industrial	C2, 1	122	grizzly.com
Jet Tools	4-5	125	jettools.com
Jet Tools	23	126	jettools.com
Jet Tools	25	127	jettools.com
Laguna Tools	C4	129	lagunatools.com
Makita	11	134	makitatools.com
Sears Craftsman	31	150	craftsman.com
Sears Craftsman	C3	151	craftsman.com
Smithy	77	153	smithy.com
Triton Workshop Systems	30	155	tritonwoodworking.com
Wilke Machinery	37	161	wilkemach.com
Woodmaster Tools	33	—	woodmastertools.com
Woodstock Int'l.	9	170	woodstockinternational.com

	PAGE #	CIRCLE #	WEB ADDRESS
SAWMILLS & KILNS			
Better Built	37	106	ripsaw.com
Grandberg	102	121	granberg.com
Nyle	20	140	nyle.com
Wood-Mizer	77	163	woodmizer.com
SHOP ACCESSORIES			
Controlled Energy Corp.	37	111	controlledenergy.com
JDS Company	15	124	thejdscompany.com
Modine	77	137	modine.com
Tool Dock	7	154	tooldock.com
Wizard Detectors	97	162	wizarddetectors.com
TURNING SUPPLIES			
Craft Supplies	20	112	woodturnerscatalog.com
Olson Saw Co.	15	141	olsonaw.com
Packard Woodworks	102	143	packardwoodworks.com
Steebar	33	—	steebar.com
WOOD & VENEERS			
Newton Woods	102	—	walnutwood.net
Niagara Lumber	34	139	niagaralumber.com
Wall Lumber	33	159	walllumber.com
West Penn Hardwoods	77	—	westpennhardwoods.com
Woodfinder	102	—	woodfinder.com
WOODWORKING CATALOGS			
Amazon	26	102	amazon.com
Rockler	33	147	rockler.com
Rockler	34	148	rockler.com
Woodcraft	16-17	164	woodcraft.com
Woodworker's Choice, The	29	171	thewoodworkerschoice.com
WOODWORKING SHOWS			
Woodworks 2002	98	—	woodworks2002.com

**See something you want?
Need more information?**

Use the Free Information Card in this issue to receive free advertiser information.

For **faster service**, go online at www.popwood.com and click "FREE INFORMATION" or **fax the card** to (585) 321-0043.

Win A Bosch Cordless Drill

When you request information, you're automatically entered in our drawing to win a Bosch Compact Tough Series 12-volt cordless drill (Model 32612), including two batteries and charger. We'll



ADVERTISER INDEX



WIZARD
INDUSTRIES, INC.

Available at Sears, Ace, & other fine stores

WITH WIZARD TOOLS... YOU WILL:

SAVE TIME! With its unique design, the new **EZ Sand Pro** allows you to use your existing quarter-sheet palm sander to quickly and accurately sand curves, angles & arcs.

SAVE MONEY! The **Little Wizard II** and **Lumber Wizard** can help prevent costly planer, jointer and saw blade damage caused by nails, screws or other metal objects hidden inside recycled and new lumber. Designed especially for woodworkers, both products include a one-year warranty.

SAVE YOUR EYES! Safety in the workshop should be a primary concern, and with Wizard's **Shop Specs Bifocal Safety Glasses**, you can see your projects more clearly and complete your work safely. Available in +1.0, +1.5, +2.0, +2.5, +3.0, the glasses are ANSI Z87.1 compliant, with integrated side shields and UV protection.

To find a retailer call or visit:
(888) 346-3826
wizind.com - info@wizind.com

New For 2003!
Ideal gifts for the woodworker or do-it-yourselfer!

CIRCLE NO. 162 ON FREE INFORMATION CARD.



OSBORNE
Wood Products, Inc.

Table Legs & More

Osborne Wood Products, Inc. offers an extensive line of dining table legs in a variety of wood species. Custom turnings are also available.

Call today or visit our website and order on-line

www.osbornewood.com

New Skirt Assemblies

Save Time!

Osborne now offers optional custom skirt assemblies on all its table legs, featuring mortise and tenon construction with pre-drilled sink holes -- shipped ready to assemble with corner brackets and hardware.

8116 Highway 123 North • Toccoa, GA 30577
Call for a catalog: 1-800-746-3233
Order line: 1-800-849-8876 • Español: 1-877-445-6034

CIRCLE NO. 142 ON FREE INFORMATION CARD.

ADVERTISER	PAGE #	CIRCLE #	WEB ADDRESS
Adams Wood Products	22	100	adamswoodproducts.com
Adams Wood Products	34	100	adamswoodproducts.com
Amana	8	101	amanatool.com
Amazon	26	102	amazon.com
Ashman Technical	34	103	woodworktools.com
Beall Tool	102	104	bealltool.com
Bench Dog Tools	8	105	benchdog.com
Better Built	37	106	ripsaw.com
Bosch	2	107	boschtools.com
Bunk Beds	103	108	—
Classic Designs	37	109	tablelegs.com
CMT	77	110	cmtusa.com
Controlled Energy Corp.	37	111	contolledenergy.com
Craft Supplies	20	112	woodturnerscatalog.com
Dakota Alert	102	113	dakotaalert.com
David Warren Direct	102	—	ecemerich.com
DCT Holdings	102	114	dctleathers.com
Delta Machinery	12	115	deltamachinery.com
Delta Machinery	13	116	deltamachinery.com
Excalibur by Sommerville	33	117	excalibur-tools.com
Fein Power Tools	27	118	feinusa.com
Forrest Mfg.	95	119	stores.yahoo.com/forrestman
Gorilla Glue	18	120	gorillaglue.com
Grandberg	102	121	granberg.com
Grizzly Industrial	C2, 1	122	grizzly.com
Heritage Building Systems	103	—	heritagebuilding.com
Hickory	21	123	oldham-usa.com
JDS Company	15	124	thedscompany.com
Jet Tools	4-5	125	jettools.com
Jet Tools	23	126	jettools.com
Jet Tools	25	127	jettools.com
Jointech	34	128	jointech.com
Laguna Tools	C4	129	lagunatools.com
Lee Valley/Veritas	24	131	leevalley.com
Lee Valley/Veritas	31	130	leevalley.com
Leigh	20, 26	—	leighjigs.com
Librawood	102	132	librawood.com
Lie-Nielsen Toolworks	28	133	lie-nielsen.com
Makita	11	134	makitatools.com
McFeely's	34	135	mcfelys.com
MLCS	35	136	mlcswoodworking.com
Modine	77	137	modine.com
Murray Clock	103	138	murrayclock.com
Newton Woods	102	—	walnutwood.net
Niagara Lumber	34	139	niagaralumber.com
Nyle	20	140	nyle.com
Olson Saw Co.	15	141	olsonasaw.com
Osborne Wood Products	97	142	osbornewood.com
Packard Woodworks	102	143	packardwoodworks.com
Polymeric Systems	102	144	epoxysticks.com
PS Wood	20	145	pswood.com
Ridge Carbide	102	146	ridgecarbide.com
Rockler	33	147	rockler.com
Rockler	34	148	rockler.com
Routerbits.com	102	149	routerbits.com
Sears Craftsman	31	150	craftsman.com
Sears Craftsman	C3	151	craftsman.com
Shortridge Co.	102	152	shorridgetd.com
Smithy	77	153	smithy.com
Steebar	33	—	steebar.com
Tool Dock	7	154	tooldock.com
Triton Workshop Systems	30	155	tritonwoodworking.com
U-bild.com	102	156	u-bild.com
U.S. Buildings	102	157	us-buildings.com
Viper	19	158	oldham-usa.com
Wall Lumber	33	159	walllumber.com
West Penn Hardwoods	77	—	westpennhardwoods.com
Whitechapel Ltd.	28	160	whitechapel-ltd.com
Wilke Machinery	37	161	wilkemach.com
Wizard Detectors	97	162	wizarddetectors.com
Wood-Mizer	77	163	woodmizer.com
Woodcraft	16-17	164	woodcraft.com
Woodcraft Plans.com	102	165	woodcraftplans.com
Woodfinder	102	—	woodfinder.com
Woodline USA	14	166	woodbits.com
Woodmaster Tools	33	—	woodmastertools.com
Woodpeckers	15	167	woodpeck.com
Woodpeckers	28	168	woodpeck.com
Woodprojects.com	102	169	woodprojects.com
Woodstock Int'l.	9	170	woodstockinternational.com
Woodworker's Book Club	Insert	—	woodworkersbookclub.com
Woodworker's Choice, The	29	171	thewoodworkerschoice.com
Woodworker's Supply	99	172	woodworker.com
Woodworks 2002	98	—	woodworks2002.com

The Ultimate Woodworking Event!

Popular
Woodworking
MAGAZINE

OFFICIAL MEDIA
SPONSOR

WoodWorks 2002 has partnered with *Popular Woodworking* to bring you the event of the year. More than an exhibitor show, WoodWorks events include free demonstrations by the very best U.S. woodworkers; classes led by experts so you can stretch your woodworking know-how; even special areas where you can turn a top or assemble a small project with your child or grandchild. And of course you'll get a hands-on look at the latest tools from big and small manufacturers alike.



3 Great Locations

FT. WASHINGTON, PENNSYLVANIA

Suburban Philadelphia

Ft. Washington Expo Center

Nov. 1, 2 & 3, 2002

WORCESTER, MASSACHUSETTS

Worcester Centrum Centre

Dec. 6, 7 & 8, 2002

ONTARIO, CALIFORNIA

Suburban Los Angeles

Ontario Convention Center

Jan. 24, 25 & 26, 2003

For more details, visit
WoodWorks2002.com
or call (310) 860-0278



**Participation
Education
Inspiration**

Meet the Experts

At WoodWorks, meet face to face with Frank Klausz, Toshio Odate, Ellis Valentine, Michael Dresdner, Wayne Barton, Paul Anthony and Andy Rae, to name just a few. Stop by the *Popular Woodworking* booth and meet the crew. Register to win the workbench we're building!

Turning Conference

A pre-event must for turners. Lectures and demos by turning legends like David Ellsworth, Stuart Mortimer, Judy Ditmer and Rolly Munro (PA and CA only).



WoodWorks 2002

...events on a higher plane

The Challenge of Cherry

It's a delightful wood to work, but it's a pain to finish. Here are strategies for getting predictable and good-looking results.

Cherry has become very popular with woodworkers in the last decade or so, at least in part because it's a beautiful wood that machines and tools easily, and it has a pleasant scent.

Compared to other woods, however, cherry is difficult to finish. You can put almost any stain or finish on oak or walnut, for example, and these woods look nice. But cherry becomes blotchy with stains and it looks better with some finishes than others. So with the caution that much of the choice in stains and finishes is determined by one's own aesthetic tastes, here are some thoughts

that may help you decide how to finish your next cherry projects.

The Finish

In my opinion, tight-grained woods such as cherry, maple, birch and pine look too flat when finished with oil finishes.

(By "oil finish" I mean linseed oil, tung oil and any blend of oil and varnish, including polyurethane varnish. You can identify these finishes by their tendency to wrinkle badly when left to cure in puddles or around the lids of their containers, and by their inability to cure hard.)

Cherry looks much better with a hard-curing, film-building finish – even if it isn't built up very much. This would include any varnish or wiping varnish (varnish thinned with paint thinner and often misleadingly labeled "tung oil"), polyurethane, shellac or lacquer, but it doesn't include water-based finish because this finish doesn't bring out cherry's rich color. Rather it leaves the wood looking "washed out."

If you're thinking of using an oil finish anyway because applying it is so easy, or you like working with water-based finish because of its lack of odor, I suggest you finish a scrap



Old cherry has a warm glow that new cherry simply cannot compete with. This antique table will continue to darken even more as the cherry is exposed to the light. Table is courtesy of Federation Antiques of Cincinnati, Ohio.

Photos by Al Parrish

board with one of these finishes when you start your project and live with it for awhile. By the time you're ready for the finishing step, you'll have a good idea of whether you're going to be happy with the look.

Beyond appearance, you're making the choice of finish primarily on durability and whether or not you're using a spray gun, the same considerations you have for choosing a finish for any wood. Varnish, polyurethane and catalyzed lacquers are more durable than shellac and nitrocellulose lacquer; and spray guns are usually best for applying fast-drying finishes such as lacquer.

The Stain

Staining is, of course, the big problem with cherry because cherry has resin pockets that get darker when any liquid is applied – and stain exaggerates the darkening. Not all cherry has these resin pockets, however, and if you choose your boards carefully, you may be able to avoid the blotching problem altogether no matter which stain you use. (To see if you're likely to get blotching, wet the wood with a liquid such as mineral spirits. Use blotchy boards in areas that won't show.)

There are two basic ways to color wood: Apply a stain directly to it; or seal or partially seal ("condition") the wood and apply the color on top. Applying stain to the wood accentuates the figure and grain (which is what most people want to do) while applying the color on top of a sealed surface muddies the wood. Applying a stain to a partially sealed surface and then wiping off the excess doesn't add much color because there's so little penetration. Nor does applying a gel stain to unsealed wood – for the same reason.

Most factory-finished cherry has the color applied on top in the form of glazes or toners in order to avoid the blotching. This is the reason factory-finished cherry doesn't look as "alive" as does old cherry that has taken on its rich coloring naturally due to light and oxidation.

Imitating the look of old cherry, with its rust-red color and almost translucent depth, is not at all difficult. You can do it with either a dye stain or with lye – with the problem being, of course, that you will accentuate any natural blotching that exists in the wood. So, if you want to achieve this look, you're going to have to choose your



This year-old cherry piece was finished with orange shellac. Its color is starting to deepen, but give it another 100 years or so to become really beautiful.

wood carefully. It should be either blotch-free, or it should have a blotch pattern that you find attractive (curly maple is a blotchy wood, after all).

You can use any brand of dye stain, but one that I find particularly effective at matching old cherry is Lockwood's water-soluble "Natural Antique Cherry" dye. You can buy this directly from Lockwood (212-966-4046 or wlockwood.com) or from Woodworker's Supply, where it is sold under the Moser name (800-645-9292 or woodworker.com).

Lockwood water-soluble dyes are very forgiving and easy to use. Follow the directions for mixing, and then apply a wet coat to an entire surface and wipe off the excess before it dries. If the wood isn't dark enough while it's still damp, wait until it dries and apply another coat. If you get the wood too dark, or if you've caused streaks by overlapping onto already dry dye, wait until the wood dries and wipe it in the direction of the grain with a wet cloth. You'll redissolve the dye colorant and remove some of it from the wood, lightening and evening the color.

There's no way to avoid the potential blotching and achieve this color, however, so you should surely experiment on scrap wood first to see what you're going to get.

Lye is very unforgiving because you can't lighten it, and I don't recommend using it because it's also dangerous. It will, however,

produce the right color, so if you decide to use it, make sure you're fully clothed and your hands and eyes are protected.

After you apply the lye, you must neutralize its alkalinity by washing the project several times with half-and-half white vinegar and water. If you don't neutralize, any water that gets through your finish and into the wood later on will activate the lye and blister the finish (lye is a very effective stripper).

Both water-soluble dye and lye require putting water on the wood, so you should wet the wood with water before staining, let the wood dry, then sand off the raised grain so the wood feels smooth again. What little grain raising you get when you then stain the wood, you can sand off easily with fine (320-or-finer-grit) sandpaper without the risk of cutting through.

To avoid blotching altogether and to not muddy the wood, the best solution for coloring cherry is to let it age naturally, just as the old cherry did.

The color will change quite rapidly (just leave a sanded board out in your shop with lots of window or fluorescent light for a couple of days and see for yourself), but it will take a very long time to reach the color of 19th-century cherry. **PW**

Bob Flexner is author of "Understanding Wood Finishing" and contributing editor to Popular Woodworking.

WOODWORKER'S MARKETPLACE

STOP BUYING LUMBER!

Mill your own...
with Granberg's Alaskan Saw Mill!



Prices
start at
\$135!

(G777 Small
Log Mill)

Use our attachment and your chain saw
to make beautiful lumber out of *any* log!
Call toll free or go online for **FREE** information!
866-233-6499 www.granberg.com

CIRCLE NO. 121 ON FREE INFORMATION CARD.

**America's Largest And
Most Trusted Manufacturer.
Order Now And Save On
Inventory Closeouts!**



Save Up to
60%
on Steel
Buildings

SAVE THOUSANDS ON SELECT SIZES
25x30 • 30x60 • 35x54 • 50x100
Additional sizes available

U.S. Buildings
www.us-buildings.com

Call
Now!

1-800-463-6062

FREE BROCHURE & FACTORY PRICE LIST

CIRCLE NO. 157 ON FREE INFORMATION CARD.

WIRELESS DRIVEWAY ALARMS



Lets you know anytime anyone
walks or drives into your place.

DAKOTA ALERT, INC.
BOX 130, ELK POINT, SD 57025
605-356-2772
www.dakotaalert.com

CIRCLE NO. 113 ON FREE INFORMATION CARD.

Routerbits.com

Bits, Blades, Books & more...

Whiteside Routerbits
Fisch Forstner Bits Systematic Saw Blades

Call Toll Free **1-888-811-7269**
www.routerbits.com

CIRCLE NO. 149 ON FREE INFORMATION CARD.

We make the world plane



For prices of 75 E.C.E. planes and other cabinet-
maker's tools, write: David Warren Direct,
7317 Chesterfield Rd., Crystal Lake, IL 60012 or
call 800-724-7758. Dealers invited. View tools
online at www.ecemmerich.com

We also make it fancy

Build a Child's Rocker

learn the intricacies
of Craftsman construction



Craftsman Rocker Kit
• precision-cut white oak or cherry
• leather upholstered seat
in black, navy, pine, or red
• complete instructions with photos

KIT • \$105
+ S&H \$15.95

All major credit cards accepted.

SHORTRIDGE
CRAFTSMAN LTD
Furniture Craftsmen

www.ShortridgeLtd.com
TOLL FREE
1-888-335-3393

20.5" H x 10.5" W x 19" D
SEAT HEIGHT 10"

CIRCLE NO. 152 ON FREE INFORMATION CARD.

"Forrest" Saw Blades

10" Woodworker II - \$97
10" Chopmaster - \$109
12" Chopmaster - \$123
8" Dado King - \$227

www.librawood.com

CIRCLE NO. 132 ON FREE INFORMATION CARD.

WoodProjects.com

3,000+ categorized
woodworking plans

10% off your order with
customer code **POPWOOD**

CIRCLE NO. 169 ON FREE INFORMATION CARD.

The Wood Buff

3-ON LATHE
MANDREL

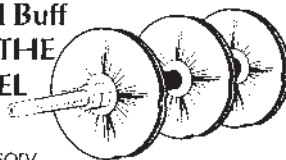

New accessory
allows you to do all three wood buffing
steps without changing wheels! Great
for pens & other small items.

For information call or write: Dept. PW

THE BEALL TOOL CO.
541 Swans Road., N.E. Newark Ohio 43055
Toll Free 1-800-331-4718
Website: www.bealltool.com

CIRCLE NO. 104 ON FREE INFORMATION CARD.

Looking for wood?

VISIT
woodfinder



It's fast, easy and **FREE!**

www.woodfinder.com

No computer? Call toll-free 1-877-933-4637

WOODWORKING PROJECT PLANS

Free 32 page catalog!
www.WoodcraftPlans.com
800.296.6256

CIRCLE NO. 165 ON FREE INFORMATION CARD.

Get a **Free Copy** of our
CATALOG for
WOODTURNERS

Call Toll Free...
1-800-683-9876



"The Woodturners' Source"

or write...
Packard Woodworks PO Box 718 Tryon, NC 28782
website: www.packardwoodworks.com

CIRCLE NO. 143 ON FREE INFORMATION CARD.

QuikWood® Epoxy Adhesive Putty Stick

repair rebuild restore bond attach patch seal

Easy to Use - No Mess



1. Cut 2. Mix 3. Fix

"When Fillers or Glue Won't Do"

Solvent
Free
VOC
Free

Shapes like modeling
clay. Can be sculpted
for fine detail. Bonds
permanently. Hardens
like wood. Sand, carve,
drill, tint, paint, and finish

888 4 FIX WOOD ext. 2209 - www.epoxysticks.com

CIRCLE NO. 144 ON FREE INFORMATION CARD.

U - BILD . COM

On-line catalog pictures hundreds of full-size
woodworking plans at low prices. Free
downloadable mini-plans. All skill levels.
Free shipping. 48-page color catalog \$2.00
(refunded on 1st order) call (800) 828-2453.

CIRCLE NO. 156 ON FREE INFORMATION CARD.

NEWTON WOODS



Featuring superior Black Walnut Burl Veneers,
Burl Slabs, Gun Stock Blanks,
Turning Wood and more.

Phone: **559-277-8456**
E-mail: newton@walnutwoods.net
Web: WalnutWoods.net

DESK TOP LEATHERS



MUIRHEAD
FINE SCOTTISH LEATHER

For color card & instructions call
DCT Holding Corp at
1-800-469-2793
Fax 416-439-9928
www.dctleathers.com

CIRCLE NO. 114 ON FREE INFORMATION CARD.

CUSTOM ROUTER BITS, CUTTERS & KNIVES

2 week or less delivery

LIBERTY LINE

WHEN IT COMES TO ROUTER BITS
WE KNOW WHAT WE'RE TALKING ABOUT.

RIDGE CARBIDE TOOL CO.

"Industry Leader In Custom Router Bits"

FAX us your custom drawings toll free at
1-888-RCT-TOOL (728-8665) or
mail drawings or wood samples

RIDGE CARBIDE TOOL CO.

595 New York Ave., PO Box 497, Lyndhurst, NJ 07071
Send \$3 for complete 100 page Stock Tool Catalog
or see us at www.ridgecarbide.com

800-443-0992 rcttool@bellatlantic.net

CIRCLE NO. 146 ON FREE INFORMATION CARD.



Build a Clock!

Clock Kits, from Grandfather to shelf clocks, including plans, movements and dials. See our entire catalogue on the web at www.murrayclock.com or send \$2 for a printed copy to:

512 McNicoll Ave.,
Willowdale ON M2H 2E1
Call 1-800-268-3181
Fax (416) 499-3686
info@murrayclock.com
www.murrayclock.com



CIRCLE NO. 138 ON FREE INFORMATION CARD.

Bunk Beds



Clear \$300/day building wood bunk beds at home. Start out in spare time & expand the business at your own pace. Earn \$185 on a \$269 sale, \$411 on a \$611 sale. Call 800-382-3180 Ext 1632. Bunks, Dept. 1632, Box 2000, Avon, MN 56310

CIRCLE NO. 108 ON FREE INFORMATION CARD.



35' x 30' x 12'

\$4,127

We Ship Anywhere in The USA!!! 10,000 Sizes. Bolt-Together All Steel Buildings & Homes. Call Today For A Price Quote And Brochure.

HERITAGE BUILDING SYSTEMS®
800.643.5555
heritagebuildings.com

Get a

FREE
sneak peek

at the latest

- woodworking tools
- woodworking news
- bargain tool prices
- workshop tips
- upcoming PW issues

Log on to popularwoodworking.com and sign up for *Popular Woodworking E-News*. This **FREE** email newsletter briefs you on the latest tips, tricks and tool tidbits we've gathered through the woodworking grapevine. *E-News* will come straight to your email box every couple weeks, so you'll get all the up-to-the-moment information you need.

Sign up today!

www.popularwoodworking.com

CLASSIFIED

Classified rate is \$4.25 per word, 15-word minimum. Order must be accompanied by payment; ads are non-commissionable. Send to: Popular Woodworking, Joan Wright, 4700 E. Galbraith Rd., Cincinnati, OH 45236, Phone: 800-388-1820, Fax: 513-531-1843.

BOOKS

WE HAVE A WIDE VARIETY of woodworking books—from small projects, to home improvement, to enhancing your woodworking skills, and more! To see our full line of books, please visit our Website at www.popularwoodworking.com/store/books!

BUSINESS OPPORTUNITIES

EASY WORK! EXCELLENT PAY! Assemble Products At Home. Call Toll Free 1-800-467-5566 Ext.3445.

\$400 WEEKLY ASSEMBLING PRODUCTS from home. Rush SASE: Home Assembly - PW, PO Box 216, New Britain, CT 06050-0216

EARN \$525 PER DAY Repairing Loose/Broken Wooden Chairs! Full/Part Time 1-877-427-7580 Dept. 902. www.thechairdoctor.com.

CARVING SUPPLIES

TURBO CARVER-Finest 450,000 RPM air powered, rotary, precision, detail hand carving & engraving instrument. Carve end grain; knot holes easily. Water cooling, dust control available. \$207 complete system. Ultra Speed Products 800-373-0707; www.turboarver.com.

FINISHING SUPPLIES/EQUIPMENT

SPRAY-ON SUEDE. Line boxes easily. Free brochure with sample. DonJer, 13142 Murphy Road, Winnebago, IL 61088; 800-336-6537; www.donjer.com

HARDWARE

EASY ORDERING! ONLINE CATALOGUES: hardware, KD & other fasteners, sanding discs, belts, lots more. Profhdwr.com & sandingproducts.com

WWW.PROFHDWR.COM Almost 3000 woodworking & related products available with our New shopping cart. Professional Hardware.

INSTRUCTION

WOODWORKING BOOT CAMP!! Summer intensive for serious woodworkers; cabinetmaking fundamentals, set up your own shop. NESAW, 413-527-6103; www.nesaw.com.

KITS & PLANS

CEDAR FLUTE CD or VHS instructional video plus illustration. 42 minutes. buy online. <http://www.flutemaking.com>.

WWW.CHERRYTREE-ONLINE.COM Clocks, toys, whirligigs, intarsia, feeders & more. Call 800-848-4363 XPOW013.

MISCELLANEOUS

POST OFFICE BOX DOOR FRONTS, #1 \$8.00; #2 \$9.00; #3 \$10.00 + S&H. Coin slot plates, etc to make banks. SASE for info. Hubbert, PO Box 1415, Fletcher, NC 28732; 828-687-0350.

TOOLS

WWW.OVERSTOCKTOOLS.COM/PW Name Brand Tools & Supplies at Closeout Prices! Check Weekly Specials!!

Special Issues from *Popular Woodworking!*

Looking for some project inspiration? Want to find the perfect power tool to fit your needs and budget? Need the perfect backyard furniture? Want to turn that awkward space in your home into a storage area? Then look no further than the **Special Issues** from the editors of *Popular Woodworking!* Inside each, you'll find all the information you need: materials selection and cutting lists, step-by-step plans, exploded drawings, and clear direction.

Storage & Shelving
Outdoor Furniture
Great American Furniture
Woodshop Essentials
Tool Buying Guides
Historic Projects
And more!

Visit www.PopularWoodworking.com for a full selection of *Popular Woodworking* Special Issues, and more!

The Old Man and the Ceiling

Forget measuring devices. All he needed was more than 50 years of experience and a tool-in-hand to calm the shakes.



While I was growing up my father and I built two houses and a cottage – from the ground up. From those experiences I learned to do almost everything you need to do to build a house (thank you, Dad) including footings, foundations, framing, roofing, plumbing and electrical work. As a consequence, whenever in-laws or friends have renovation projects or are wiring a basement, I am invariably involved.

One day, while I was working on my brother-in-law's Victorian home, he mentioned that he wanted to put a wooden strip ceiling in his study along with some crown moulding. I said I would help him, but he told me there was no need as he had found “this old guy” to do the work.

The next day this gentleman arrived and I immediately went into shock. This guy had to be 90 with the craggiest face I have ever seen – some of his wrinkles rivaled the depth of the Grand Canyon. He was carrying a ladder that had to be as old as he was and with about as many cracks in the rungs.

The old man stopped to talk to us, and he was shaking so much that he could barely hold on to his cigarette. I thought to myself, “This rickety old fellow is never going to be able to do the ceiling.”

All the lumber for the project was already stacked in the room. He set up the ladder and opened up his toolbox. All that was in there was a bunch of saws that had seen better days, a couple of hammers, some sandpaper and a block plane.

The moment he picked up his tools, all the shakiness disappeared. He grabbed a board, the hammer and some nails and walked up the ladder like it was a rock-steady set of stairs and proceeded to put the first board in place. Of course the boards were all different lengths, requiring him to go up and down the ladder again and again. But he moved as fast as a bunny. He hammered happily away, whistling, with a cigarette dangling from his lips.

As he started to fit pieces to fill in the spaces to meet the walls I watched an amazing thing. This old man would pick up a board and spend about a minute looking at the ceiling, then back to the board and then the ceiling again. Then he would mark a spot on the board with his thumb, rest one end of the board on a step of the ladder and the other across his knee. While standing up and balanced on one leg, he would cut the board at the thumb mark. Then he'd walk up the ladder, put the board in place and it would be the perfect length.

He did this with every board and was never more than a 1/4" to 1/2" out at the walls. He told me he wasn't worried about being too accurate because those spaces would be covered up when he put the crown moulding up. And, he said that the wood needed to breathe anyway.

Now if you've ever worked on an old house you know that the walls are rarely square. This house was the same way, so when the old man came to the edges of the room the

boards would have to be cut at a wide variety of angles in order to fit properly. That is where the plane came in. He did the same thing here as he had done earlier. He looked at the ceiling and then looked at the board. Then he would plane the edge freehand, walk up the ladder and fit the board in perfectly. I only saw him come down that ladder once to correct a fitting problem.

The old man finished the entire 14' x 12' ceiling in one day (seven hours), and yes he did the crown moulding the same way he worked the other boards. No miter boxes were involved. Rather he would draw a line using a pencil and a stick of wood where he wanted to make his cut.

Every time the old man didn't have a tool in his hands he got the shakes. Hammer in hand – no shakes. Put the hammer down – he would shake like a kitten.

Over a beer that night I asked him how he had learned to work with such accuracy without a tape measure or a square, and how he cut so perfectly without a miter box.

He looked at me with a twinkle in his eyes and said something along these lines: “Well sonny, I've been doing this for 75 years and after 50 years at the job I finally got really good at it.” **PW**

Ben Knebel, plane-maker, is vice president of marketing and sales for the Shepherd Tool Co. In addition to making planes, Ben avidly collects British tools and loves to tell stories. You can read more of his stories at shepherdtool.com.

SAWED-OFF. PINT-SIZED. PUNY.

(THE ACCOLADES JUST KEEP ON COMING)

If this doesn't look like much of a drill to you, well, that's precisely the point. Its 3.2 amp motor actually has the same power as the motor in our standard 3/8"

drill. But by putting it in the handle, we were able to shorten the head of the drill to a measly 4.75 inches. We call it the Mini-T Drill. And as you've probably already guessed, it can fit into all kinds of places that other drills can't. Like between studs. Or behind refrigerators. Or under decks. (Imagine the possibilities.) For a small drill, the Mini-T is also surprisingly big

SEARS
Where else?™

on features. For starters, it has a no-slip, vibration-dampening cushioned grip. There's also a convenient trigger lock (think cruise control)

for extended running. And you'll love its one-touch reverse button, which makes one-handed use a breeze. Plus, at just 3.5 lbs., it's a real lightweight. Other

specs include a 3/8" chuck. A motor that goes from 0 to 1,500 RPM with multiple speeds. And a generous 8-foot cord. You get all of this (in a handy carrying case, we may add) for the relatively puny price of \$139.99.

So look for it at a Sears or Sears Hardware Store near you.

Or order it by phone at 1-800-437-9686.

You can even get this

little gem online at www.craftsman.com.

Because sometimes, getting out of a tight spot requires a tool that can get into one.



CRAFTSMAN
PROFESSIONAL

It's
our
20th
anniversary
but
you
get
the
gifts!



Choose The Knapp

Absolutely the best combination machine, custom-made to your precise specifications. Call today to order your free demonstration video and see why the Knapp multi-task machine performs more like a metal machine.

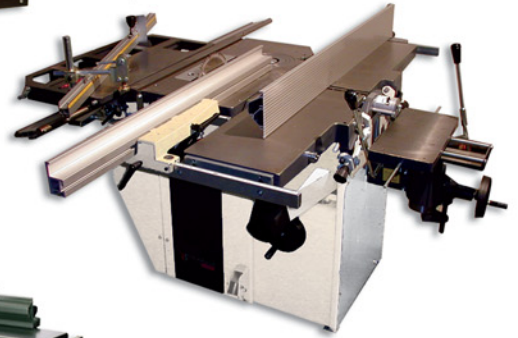

Choose the X31

The revolutionary X31 set new performance standards when we introduced it 14 years ago. Packed with features and powered by three separate 3 HP motors, home woodworkers can achieve results comparable with the best, fully equipped professional shops.

Choose the New NX31 or NLX

Get professional features you want at prices any hobbyist can afford with Laguna Tools' latest combination machine innovations. Built to meet our meticulous quality control standards, these machines have the five precision tools master woodworkers demand: 12" jointer with 12" planer to dimension lumber, 3 HP shaper, 3 HP cast-iron mortiser, 12" table saw with 60" or more sliding table panel saw, 10-second change-over time, three separate 3 HP motors, and a separate professional panel saw for improved, precise cutting (NX31 only).

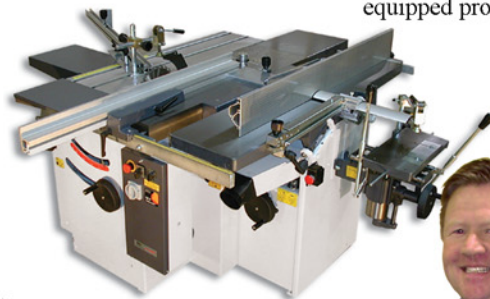

FREE

FREE 5' EUROPEAN WORKBENCH



VALUE \$895.



VALUE \$1,130

FREE LT 14 BANDSAW



VALUE \$895.

LAGUNA TOOLS

YOU BUILD WITH WOOD, WE BUILD WITH TRUST.

17101 Murphy Avenue
Irvine, CA 92614
www.lagunatools.com

T- 949.474.1200
F- 949.474.0150
E- mail@lagunatools.com

Offer valid for machines purchased and shipped between January 1 and July 31, 2009. Subject to availability.

CALL FOR FREE VIDEO
800.234.1976

CIRCLE NO. 129 ON FREE INFORMATION CARD.