

PLUNGE ROUTER RUMBLE: WHO'S LEFT STANDING?
AUTHENTIC ARTS & CRAFTS FINISH: 5 SIMPLE STEPS TO SUCCESS

JUNE 2002
ISSUE #128

Popular Woodworking

2002 TOOL REPORT

We strip down **20 TOOLS**
and report the **NAKED** truth

7 RULES OF RESAWING

Tune your band saw;
make flawless cuts

6 Pro Tricks TO PERFECT BEDS

Easiest methods
ever produce
rock-solid
results



www.popwood.com
\$4.99 U.S. \$7.99 CAN





Actor Dan Haggerty with Ben, Stars of "Grizzly Adams"

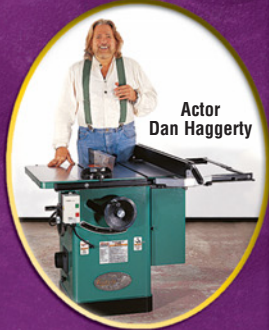

Actor Dan Haggerty

"I love dealing with Grizzly Industrial. They have excellent products and stand behind everything they sell."

Dan Haggerty



"Please, can we buy it, honey?"



Grizzly Industrial®

PURVEYORS OF FINE MACHINERY™ - SINCE 1983

MODEL G8794 12 1/2" PORTABLE PLANER

- 2 H.P., 110V MOTOR, 15 AMPS
- CUTTERHEAD SPEED: 8,540 R.P.M.
- FEED RATE: 25 F.P.M.
- NUMBER OF PUTS PER INCH: 57
- MIN. BOARD THICKNESS: 3/16"
- MAX. CUTTING WIDTH: 12 1/2"
- MAX. CUTTING HEIGHT: 6"
- MAX. CUTTING DEPTH: 1/16"
- APPROX. SHIPPING WEIGHT: 85 LBS.



ONLY \$289⁹⁵

\$30 SHIPPING ANYWHERE IN LOWER 48 STATES

FREE STAND INCLUDED WITH G8794 PLANER (700LB. CAPACITY)

MODEL G1021Z 15" PLANER W/ CABINET STAND

- 3 H.P., 220V, SINGLE-PHASE MOTOR
- PRECISION GROUND CAST IRON BED
- CUTTERHEAD SPEED: 5000 R.P.M.
- RATE OF FEED: 16 F.P.M. & 20 F.P.M.
- MAX. CUTTING WIDTH: 14 1/2"
- MAX. CUTTING HEIGHT: 6 1/8"
- MAX. CUTTING DEPTH: 1/8"
- NUMBER OF KNIVES: 3
- ALL BALL BEARING CONSTRUCTION
- APPROX. SHIPPING WEIGHT 540 LBS.



ONLY \$995⁰⁰

\$125 SHIPPING ANYWHERE IN LOWER 48 STATES

MODEL G1033 20" PLANER

- 3 H.P., 220V, SINGLE-PHASE MOTOR
- TABLE IS PRECISION-GROUND TO A MIRROR-LIKE FINISH
- CUTTERHEAD SPEED: 4833 R.P.M.
- RATE OF FEED: 16 F.P.M. & 20 F.P.M.
- MAX. CUTTING WIDTH: 20"
- MAX. CUTTING HEIGHT: 8 3/8"
- MAX. CUTTING DEPTH: 1/8"
- NUMBER OF KNIVES: 4 H.S.S.
- HEAVY-DUTY CAST IRON CONSTRUCTION
- APPROX. SHIPPING WEIGHT: 785 LBS.



ONLY \$1,295⁰⁰

\$150 SHIPPING ANYWHERE IN LOWER 48 STATES

4 BLADE CUTTERHEAD!
TOOL BUYING GUIDE
Editors Choice
WOOD WORKING
SPECIALTY
TOOL

MODEL G1182HW 6" x 47" JOINTER WITH HANDWHEELS

- 1 H.P., SINGLE-PHASE, 110/220V MOTOR (PRE-WIRED TO 110 V)
- HEAVY-DUTY ONE PIECE STEEL STAND W/BUILT IN CHIP CHUTE
- PRECISION GROUND CAST IRON BED
- SUPER HEAVY-DUTY, CENTER-MOUNTED FENCE - POSITIVE STOPS @ 45° & 90°
- 3 KNIFE BALL BEARING CUTTERHEAD
- TABLE SIZE: 6" x 47"
- 1/2" RABBETING CAPACITY
- APPROX. SHIP. WEIGHT: 215 LBS.



FREE PAIR OF SAFETY PUSH BLOCKS

ONLY \$325⁰⁰

\$55 SHIPPING ANYWHERE IN LOWER 48 STATES

TOOL BUYING GUIDE
Editors Choice

MODEL G1182ZX 6" x 47" HEAVY-DUTY JOINTER

- 1 H.P., SINGLE-PHASE, 110/220V MOTOR (PRE-WIRED TO 110 V)
- HEAVY-DUTY ONE PIECE STEEL STAND W/BUILT IN CHIP CHUTE
- PRECISION GROUND CAST IRON BED
- RE-DESIGNED FENCE SYSTEM - POSITIVE STOPS @ 45° & 90°
- 3 KNIFE BALL BEARING CUTTERHEAD
- TABLE SIZE: 6" x 47"
- 1/2" RABBETING CAPACITY
- APPROX. SHIPPING WEIGHT: 235 LBS.



FREE PAIR OF SAFETY PUSH BLOCKS

ONLY \$475⁰⁰

\$55 SHIPPING ANYWHERE IN LOWER 48 STATES

MODEL G1018HW 8" x 65" SUPER HEAVY-DUTY JOINTER

- 3-KNIFE CUTTERHEAD IS 3" IN DIA. AND RUNS IN SHIELDED, PRE-LUBRICATED BALL BEARINGS
- POWERFUL 1 1/2 H.P., 220V SINGLE PHASE MOTOR
- EASILY PLOWS THROUGH HARDWOODS
- MAXIMUM DEPTH OF CUT IS 1/2" AND INFED TABLE HAS RABBETING LEDGE
- SUPER HEAVY-DUTY CAST IRON BED
- APPROX. SHIPPING WT. 450 LBS.



ONLY \$695⁰⁰

\$75 SHIPPING ANYWHERE IN LOWER 48 STATES

FREE PAIR OF SAFETY PUSH BLOCKS

MODEL G1035 1 1/2 H.P. SHAPER

- 2 INTERCHANGEABLE SPINDLES: 1/2" AND 3/4"
- HEAVY-DUTY 1 1/2 H.P., 110/220V MOTOR
- TWO SPINDLE SPEEDS: 7,000 AND 10,000 R.P.M.
- SPINDLE OPENINGS: 1 1/4", 3 1/2", AND 5"
- PRECISION-GROUND CAST IRON TABLE
- 3" SPINDLE TRAVEL
- TABLE SIZE: 20 1/4" x 18"
- FLOOR-TO-TABLE HEIGHT: 33 1/2"
- ALL BALL BEARING CONSTRUCTION
- MAX. CUTTER DIAMETER: 5"
- APPROX. SHIPPING WEIGHT: 220 LBS.



G1706 EXTENSION WING SHOWN NOT INCLUDED

ONLY \$425⁰⁰

\$55 SHIPPING ANYWHERE IN LOWER 48 STATES

MODEL G1026 3 H.P. SHAPER

- 3 INTERCHANGEABLE SPINDLES: 1/2", 3/4" AND 1"
- 3" SPINDLE TRAVEL
- HEAVY-DUTY 3 H.P., SINGLE-PHASE, 220V MOTOR WITH REVERSING SWITCH
- TWO SPINDLE SPEEDS: 7,000 AND 10,000 R.P.M.
- SPINDLE OPENINGS: 1 1/2", 2 1/4", 4", AND 5 1/2"
- PRECISION-GROUND CAST IRON TABLE
- TABLE SIZE WITH STANDARD WING ATTACHED: 30 1/2" x 28 1/4"
- FLOOR-TO-TABLE HEIGHT: 34"
- APPROX. SHIPPING WEIGHT: 353 LBS.



ONLY \$825⁰⁰

\$75 SHIPPING ANYWHERE IN LOWER 48 STATES

MODEL G1019Z 14" BANDSAW

- CUTTING CAPACITY/THROAT: 14 1/4"
- MAXIMUM CUTTING HEIGHT: 6 3/8"
- OVERALL SIZE: 66"H x 26"W x 22"D
- TABLE HEIGHT ABOVE FLOOR: 42 1/2"
- TABLE TILT: 45° RIGHT, 10° LEFT
- WHEELS: FULLY BALANCED CAST ALUMINUM WITH RUBBER TIRES
- MOTOR: 1 H.P., TEFC, 110V / 220V SINGLE PHASE
- AMPS: 12@110V / 6@220V
- BLADE SPEEDS: 2500 & 3350 F.P.M.
- BLADE SIZE: 98" (1/8" TO 3/4" WIDE)
- APPROX. SHIP. WT. 165 LBS.



ONLY \$335⁰⁰

\$55 SHIPPING ANYWHERE IN LOWER 48 STATES

CALL TODAY FOR YOUR FREE 468 PAGE COLOR CATALOG

395001658

MEDIA CODE AD1367

1-800-523-4777

CUSTOMER SERVICE: (570) 546-9663 FAX: (800) 438-5901

3 Locations: Bellingham, WA • Springfield, MO • Muncy, PA

CIRCLE NO. 107 ON FREE INFORMATION CARD.

WE SELL DIRECT TO THE USER! NO DEALERS AND NO MIDDLEMEN! BUY DIRECT & SAVE!

- FULL 1-YEAR WARRANTY ON ALL MACHINES • MOST ORDERS SHIPPED THE SAME DAY
- HUGE PARTS FACILITY WITH OVER 1 MILLION PARTS IN STOCK AT ALL TIMES
- WE HAVE 2 OVERSEAS QUALITY CONTROL OFFICES STAFFED WITH QUALIFIED ENGINEERS



New!

NEW TABLE SAWS FOR 2002!

MODEL G1022PRO 10" HEAVY-DUTY TABLE SAW WITH SHOP FOX® CLASSIC FENCE

- 2 H.P. MOTOR
- PRECISION GROUND TABLE & WINGS
- WIDE & STABLE STAND
- 3/8" x 1 1/4" BALL BEARING ARBOR
- 37" TABLE HEIGHT
- 3 1/2" CUTTING CAPACITY AT 90°, 2 1/2" AT 45°
- SEE THRU BLADE GUARD
- TABLE HAS BEVELED EDGE & T-SLOTS
- 27 1/2" x 40 1/2" TABLE SIZE
- PRECISION SHOP FOX® FENCE
- CAST IRON MITER GAUGE ADJUSTS TO ELIMINATE ANY PLAY IN MITER SLOT
- MACHINED STEEL PULLEYS
- POWER TWIST® DRIVE BELT
- 4" DUST PORT • 25" RIP CAPACITY
- SMOOTHER ACTION HANDWHEELS
- SHIPPING WEIGHT APPROX.: 290 LBS.

INCLUDES SHOP FOX® CLASSIC FENCE!



FULLY ADJUSTABLE CAST IRON MITER GAUGE

ONLY \$550⁰⁰
\$75 SHIPPING ANYWHERE IN LOWER 48 STATES

MODEL G1023SL 10" LEFT-TILTING SUPER HEAVY-DUTY TABLE SAW

- 3 H.P. SINGLE-PHASE, 220V MOTOR
- SOLID CAST IRON TABLE
- TABLE HAS T-SLOTS SO YOUR MITER GAUGE WILL NOT FALL OFF THE TABLE WHEN RETRACTED
- TABLE SIZE (WITH 2 SOLID EXTENSION WINGS ATTACHED) IS 40 1/2" x 27"
- EXTRA-LARGE HANDWHEELS
- CUTTING CAPACITY: 8" LEFT AND 26" RIGHT OF BLADE
- MAXIMUM DEPTH OF CUT @ 90°: 3"
- MAXIMUM DEPTH OF CUT @ 45°: 2 1/2"
- 3/4" DIAMETER ARBOR IS LONG ENOUGH TO ACCEPT DADO BLADES UP TO 1 3/8"
- ONE-PIECE STEEL CABINET-TYPE STAND
- MAGNETIC SAFETY SWITCH IS STANDARD
- ALL SEALED BALL BEARING CONSTRUCTION
- TRIPLE V-BELT DRIVE
- POWDER COATED PAINT
- SHIPPING WEIGHT APPROX. 430 LBS.

New!



INTRODUCTORY PRICE \$895⁰⁰
\$75 SHIPPING ANYWHERE IN LOWER 48 STATES

MODEL G1022SM 10" HEAVY-DUTY TABLE SAW

- TABLE SIZE W/ EXTENSION WINGS: 27 1/2" x 40 1/2"
- RAIL DIMENSIONS: 44" x 1 1/2" • MAX. RIPPING CAPACITY: 24"
- CUTTING CAPACITY AT 90°: 3 1/2" • CUTTING CAPACITY AT 45°: 2 1/2" • 1 1/2" H.P., SINGLE-PHASE, 110/220V MOTOR (PRE-WIRED TO 110V)
- APPROX. SHIPPING WEIGHT: 220 LBS. • PRECISION GROUND CAST IRON TABLE

Popular Woodworking
TOOL BUYING GUIDE
Editor's Choice



ONLY \$325⁰⁰
\$55 SHIPPING ANYWHERE IN LOWER 48 STATES

MODEL G7947 12 SPEED 17" FLOOR DRILL PRESS

- 1 H.P., SINGLE PHASE, 110V/220V MOTOR
- 12 SPEEDS: 210-3300 RPM
- OVERALL HEIGHT: 64 1/2" • SWING: 17"
- DRILL CHUCK: 3/8" • DRILLING CAPACITY: 1" STEEL
- SPINDLE TAPER: MT #3 • SPINDLE TRAVEL: 4 1/4"
- TABLE SIZE: 13 3/8" Sq.
- PRECISION GROUND CAST IRON TABLE
- TABLE TILT: 90° IN BOTH DIRECTIONS
- APPROX. SHIPPING WEIGHT: 275 LBS.

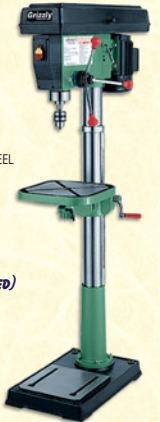

BUILT-IN LIGHT! (BULB NOT INCLUDED)

ONLY \$375⁰⁰
\$75 SHIPPING ANYWHERE IN LOWER 48 STATES

MODEL G1029 2 H.P. DUST COLLECTOR

- MOTOR AMP DRAW: 12 AMPS (220V ONLY)
- 2 H.P., 220V, SINGLE-PHASE MOTOR
- R.P.M.: 3450
- STANDARD BAG FILTRATION: 30 MICRON
- PORTABLE BASE SIZE: 21 1/2" x 33 1/2"
- AIR SUCTION CAPACITY: 1550 C.F.M.
- STATIC PRESSURE: 12.3"
- APPROX. SHIPPING WEIGHT: 130 LBS.



WOODWORKING
READER'S CHOICE AWARDS
TOOL BUYING GUIDE
Editor's Choice

FREE CYCLONE SEPARATOR!

ONLY \$249⁹⁵
\$55 SHIPPING ANYWHERE IN LOWER 48 STATES

MODEL G1066 24" DRUM SANDER

- 5 H.P., 220V DRUM MOTOR DRIVES 2 ALUMINUM SANDING DRUMS
- 1/4 H.P. CONVEYOR MOTOR GIVES AN 11 FPM RATE OF FEED
- 2 BUILT-IN 4" DUST PORTS FOR EASY HOOK-UP TO COLLECTION SYSTEM
- ALL STEEL AND BALL BEARING CONSTRUCTION
- STATE-OF-THE-ART COMPUTER BALANCED DRUMS
- APPROX. SHIPPING WEIGHT: 430 LBS.
- HANDLES STOCK UP TO 23 1/2" WIDE x 4 1/4" THICK



ONLY \$1095⁰⁰
\$75 SHIPPING ANYWHERE IN LOWER 48 STATES

New!

MODEL G9983 15" WIDE-BELT SANDER (OPEN END)

- OVERALL DIMENSIONS: 61 3/4" H x 32 1/2" D x 35" W
- CONVEYOR SPEED 13 & 16.4 F.P.M.
- BELT FEED MOTOR: 1/4 H.P.
- SANDING BELT MOTOR: 5 H.P.
- REQUIRES SINGLE-PHASE, 220V ELECTRICAL AND 50-70 PSI AIR
- INCLUDES EXTENDED SUPPORT BAR FOR WIDE BOARDS
- APPROX. SHIPPING WEIGHT: 1,000 LBS.



ONLY \$2,795⁰⁰
\$200 SHIPPING ANYWHERE IN LOWER 48 STATES

MODEL G9922 OSCILLATING SPINDLE SANDER

- 1/2 H.P., SINGLE PHASE, 4.6 AMP, TEFC MOTOR
- GROUND CAST IRON 14 1/2" x 14 1/2" TABLE TILTS TO 45°
- STROKE LENGTH: 1"
- FLOOR-TO-TABLE HEIGHT: 39 1/2"
- BUILT-IN 2" DUST COLLECTION PORT
- 3450 R.P.M. SPINDLE SPEED
- SPINDLE OSCILLATES AT 64 STROKES-PER-MINUTE
- SHIELDED & PERMANENTLY LUBRICATED BALL BEARINGS
- INCLUDES 80 GRIT SLEEVE FOR SPINDLE, MITER GAUGE AND WRENCH SET
- APPROX. SHIPPING WEIGHT: 95 LBS.



ONLY \$175⁰⁰
\$30 SHIPPING ANYWHERE IN LOWER 48 STATES

MODEL G1071 OSCILLATING SPINDLE SANDER

- 1 H.P., SINGLE PHASE, 110/220V, TEFC MOTOR
- PRECISION GROUND CAST IRON 25" x 25" TABLE TILTS TO 45°
- STROKE LENGTH: 1 1/2"
- FLOOR-TO-TABLE HEIGHT: 35 1/2"
- BUILT-IN 4" DUST COLLECTION PORT
- 1725 R.P.M. SPINDLE SPEED
- SPINDLE OSCILLATES AT 72 S.P.M.
- 10 TAPERED AND THREADED SPINDLE SIZES
- PERMANENTLY LUBRICATED BALL BEARINGS
- INCLUDES 100 GRIT SLEEVE FOR EACH SPINDLE, MITER GAUGE AND WRENCH SET
- APPROX. SHIPPING WEIGHT: 300 LBS.



ONLY \$525⁰⁰
\$75 SHIPPING ANYWHERE IN LOWER 48 STATES

grizzly.com

OVER 10,000 PRODUCTS AVAILABLE ONLINE!

RECEIVE A **FREE GIFT** WITH EVERY ONLINE ORDER
(LIMITED TIME OFFER)

CIRCLE NO. 108 ON FREE INFORMATION CARD.



Bonds Everything ~~But~~ ^{including} The Kitchen Sink.

For over 50 years, Titebond® glues and adhesives have set the industry standard for excellence in performance and application. Introducing the HiPURformer™ Advanced Bonding System. It combines the highest-quality polyurethane hot-melt adhesives with the most efficient, cost-effective application system.

Throw in the kitchen sink and you've got the perfect solution for all your bonding needs.

brick, plastics, concrete, melamine, wood, ceramic... even the kitchen sink.
leather, porcelain, marble, metal, glass, FRP, stone, foamboard, moldings, fabrics (fabrics), textiles (fabrics)

Don't let this unique opportunity go down the drain. Call today for more information on how the HiPURformer™ Advanced Bonding System will improve your woodworking, remodeling and repair experience.



Franklin International

Columbus, Ohio 43207 • 800-347-4583 • titebond.com

CIRCLE NO. 106 ON FREE INFORMATION CARD.



TOOLS AND TECHNIQUES

18 Thumb-saving Push Stick

TRICKS OF THE TRADE

This thoughtful and simple push stick keeps your thumb from slipping onto the blade. Also, build a simple ammonia fuming chamber and protect small blades from rust.

26 Bosch Sander Eats its Dust

TOOL TEST

Bosch's latest 5" random-orbit sander removes stock quickly, yet keeps the dust out of your lungs. Also tested: Freud's router-table fence and Bench Dog's ProLift.



28 Band-sawn Pencil Posts

INGENIOUS JIGS

There are several ways to cut octagonal pencil posts for the traditional bed featured in this issue. Here's a method for woodworkers who like working on the band saw.

By Nick Engler

31 Jet's JPM-13 Planer/Molder

ENDURANCE TEST

Priced between a portable planer and a 15" model, the Jet JPM-13 has big-planer features and the ability to cut miles of moulding. Find out how ours fared after years of use.

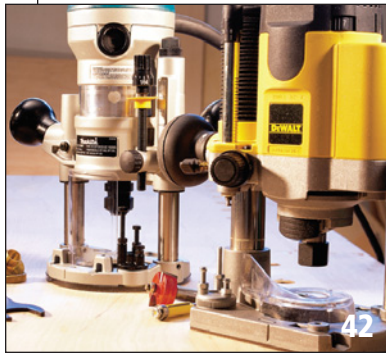

42 Premium Plunge Routers

These mid-sized plungers have finesse, guts and lots of features. We test four of the most popular models to find out who has the smoothest and most accurate machine.

46 Tape Measures

The lowly tape measure is the difference between parts that fit and parts that make you throw a fit. Buy a good tape measure. Here's how.

48 Parallel-jaw Clamps

Until recently, Bessey K-bodies were the parallel-jaw clamp of choice. Gross Stabil and Jorgensen now hope to dethrone the red leader with new lines of clamps. We strip them down and clamp them up to get some answers.

58 Resawing With the Band Saw

The trick to effortless resawing is choosing the right blade, tuning up your saw and aligning the fence properly. Here's how to do all three like a pro.

By Lonnie Bird

68 Arts & Crafts Finish

You don't have to fume your projects with ammonia to get a rich turn-of-the-century finish. We show you how to get great results using dye and glaze.





42

ON THE COVER

Mid-size plunge routers are capable of almost any routing chore in the home workshop. We run them all through their paces and pick the best for you.

Cover photo by Al Parrish.

IN EVERY ISSUE

6 **Out on a Limb**
Time to Shape Up

8 **Letters**
Mail from readers

14 **Q & A**
We answer readers' most difficult questions

22 **American Woodshops**
Scott Phillips gives you an inside look at his new shop

76 **Flexner on Finishing**
The Case for Shellac

79 **Caption the Cartoon**
Win a Freud FJ85 jigsaw

80 **Out of the Woodwork**
Snakes, Scrap Wood and Justice
by Walt Akers

PROJECTS

32 **Building the Perfect Bed**

With these simple tricks, you can build any size bed that's as sturdy as a mule. Plus, we give you the plans for this easy and elegant pencil-post design.

By Troy Sexton

38 **Arts & Crafts Globe Stand**

If you have a library or a taste for adventure, a stand for your globe is just the right project. If this design doesn't suit you, we also offer three other options.

By Dan Brody



32



52

52 **Shaker Press Cupboard**

A single drawer and two doors make this useful cabinet a challenge for the beginning woodworker, without being an overwhelming undertaking.

By Glen Huey

62 **Drop-lid School Desk**

Built entirely with hand tools (though there's no sin in firing up your router), this small desk is a lesson in traditional woodworking and dealing with wood movement.

By Dale Lucas

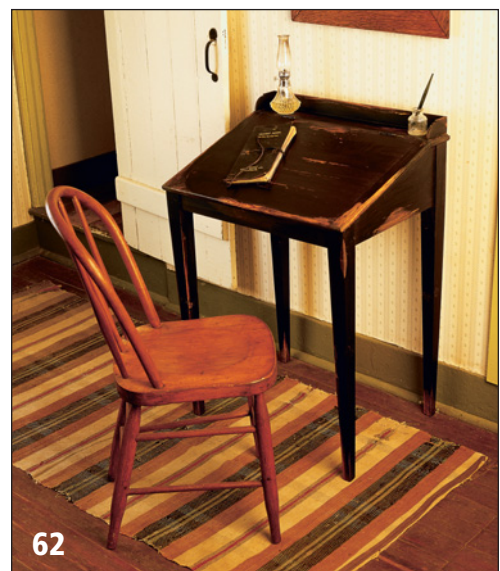

62

Popular Woodworking (ISSN 0884-8823, USPS 752-250) is published six times a year in February, April, June, August, October and December by F&W Publications Inc. Editorial and advertising offices are located at 1507 Dana Ave., Cincinnati, OH 45207; tel.: 513-531-2222. Unsolicited manuscripts, photographs and artwork should include ample postage on a self-addressed, stamped envelope (SASE); otherwise they will not be returned. Subscription rates: A year's subscription (6 issues) is \$24.96; outside of U.S. add \$7/year • Canada Publications Mail Agreement No. 40025316. Canadian return address: 2744 Edna St., Windsor, ON N8Y 1V2 • Copyright © 2002 by *Popular Woodworking*. Periodicals postage paid at Cincinnati, Ohio, and additional mailing offices. Postmaster: Send all address changes to *Popular Woodworking*, P.O. Box 5369, Harlan, IA 51593 Canada GST Reg. # R122594716 • Produced and printed in the U.S.A. Ride-along enclosed in polybag version 52000.

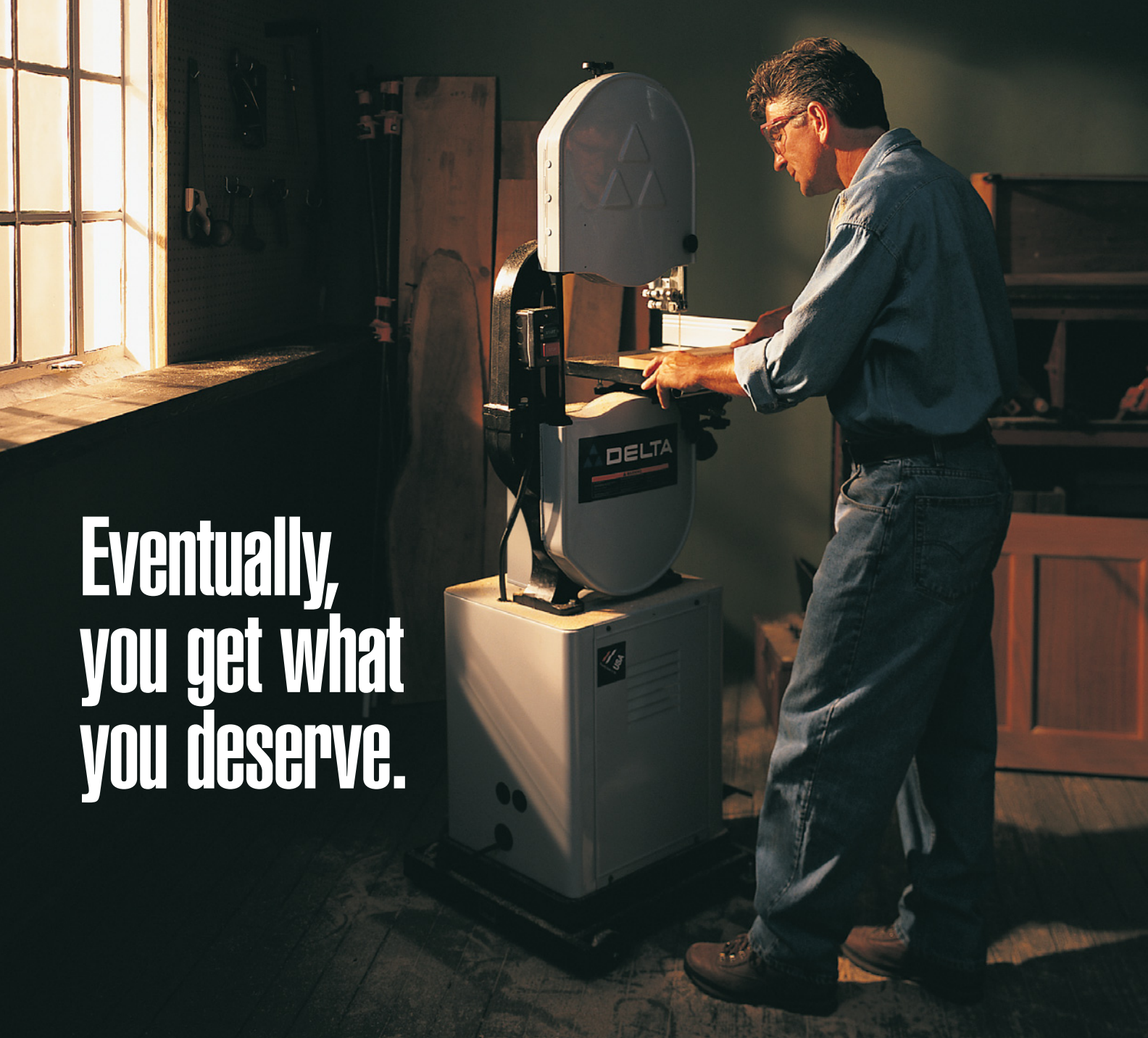

Eventually,
you get what
you deserve.

Get hundreds of dollars worth of free accessories with these **Limited Edition** Delta machines.

All the time, all the effort, all the talent. You put a lot into your woodworking. Which is why we've put together a deal you can get a lot out of. Right now, buy any one of 11 Delta machines – the same tools seasoned woodworkers have always relied on for uncompromising quality – and we'll give you a long list of accessories absolutely free. From mobile bases to cast-iron wings, table boards to carbide-tipped saw blades* The way we see it, you've got it coming to you. For the name of your nearest dealer, call Delta Machinery at 800-438-2486 (U.S.) or 519-836-2840 (Canada). Or visit deltamachinery.com.



Delta is a proud sponsor of these PBS programs.
CIRCLE NO. 104 ON FREE INFORMATION CARD.

*Accessory packages vary by product.

 **DELTA**[®]
SERIOUS WOODWORKING TOOLS SINCE 1919.

June 2002, Vol. 22, No. 3
www.popularwoodworking.com

Editorial Offices 513-531-2690

Editor & Publisher **Steve Shanesy**
ext. 238 • steve.shanesy@fwpubs.com

Art Directors **Linda Watts, Tricia Barlow**

Senior Editor **David Thiel**
ext. 255 • david.thiel@fwpubs.com

Senior Editor **Christopher Schwarz**
ext. 407 • chris.schwarz@fwpubs.com

Assistant Editor **Kara Gebhart**
ext. 348 • kara.gebhart@fwpubs.com

Project Illustrator **John W. Hutchinson**

Photographer **Al Parrish**

Contributing Editors

**Nick Engler
Bob Flexner
Glen Huey
Scott Phillips
Troy Sexton**

Senior Vice President **David Lewis**
Editorial Director **David Fryxell**

CIRCULATION

David Lee, Vice President
Jennifer Shaffer, Group Manager

PRODUCTION

Barbara Schmitz, Vice President
Heather Griffin, Production Coordinator

ADVERTISING

Advertising Director

Don Schroder

331 N. Arch St., Allentown, PA 18104
Tel. 610-821-4425; Fax 610-821-7884
d.schroder@verizon.net

Classified Advertising Sales

Joan Wright, Tel. 800-388-1820
joanwright@ix.netcom.com

Advertising Production Coordinator
Debbie Thomas, Tel. 513-531-2690, ext. 219
debbie.thomas@fwpubs.com

SUBSCRIPTION SERVICES Subscription inquiries, orders and address changes can be made at www.popwood.com (click on Subscriber Services). Or by mail: Popular Woodworking, P.O. Box 5369, Harlan, IA 51593 or call 515-280-1721. Include your address with all inquiries. Allow 6 to 8 weeks for delivery.

NEWSSTAND DISTRIBUTION Curtis Circulation Co., 730 River Rd., New Milford, NJ 07646

ATTENTION RETAILERS:

To carry *Popular Woodworking* in your store, call RetailVision at 1-800-381-1288 ext. 6050 or write RetailVision, 23 Pond Lane, Middlebury VT 05753.

Back issues are available for \$6.50 (\$8.50 Canada; \$10.50 other foreign). Send check or money order to: Popular Woodworking/F&W Publications Products, P.O. Box 2031, Harlan IA, 51593; or call 888-419-0421. Please specify publication, month and year.

SAFETY NOTE:

Safety is your responsibility. Manufacturers place safety devices on their equipment for a reason. In many photos you see in *Popular Woodworking*, these have been removed to provide clarity. In some cases we'll use an awkward body position so you can better see what's being demonstrated. Don't copy us. Think about each procedure you're going to perform beforehand. Safety First!

Time to Shape Up

Making the case for shapers in the woodshop.

Let me be the first to confess: You haven't seen "boo" in this magazine about wood shapers. You haven't seen a tool review, a technique article or even a mention about using one during a project. On the other hand, we've shown you dozens of router table setups, router table reviews, even how to build your own router table and fence.

And during the past several years I've groused time and again to the staff about how expensive these items are. It got to the point that I canceled a planned router table review and then threw down the gauntlet – "I can build a great router table for \$50." It was featured in the June 2001 issue.

Don't get me wrong, some of these aftermarket accessories are well made and will provide years of good service. One of the latest examples is the "router lift" mechanism. The engineering and performance on some of these products is tremendous.

But throughout the years, woodworkers' love of the router (a passion I share) has been exploited by companies that have introduced one product after another to make the hand-held router more versatile. Looked at separately, a router table, a nice router fence and a router lift are all good ideas.

But when you put them all together, the only thing greater than the sum of the parts is the expense involved. It's an expense that is far greater than a light-duty wood shaper, which provides superior performance.

Do the math. First, you need a good medium- to heavy-duty router: \$200. Add to that a router table and fence: \$350. Put on a router lift mechanism: \$350. OK, that's \$900, and there's bound to be another gizmo that will get you to \$1,000 faster than you can whip out your credit card.

Compared to any router table setup, the shaper is a beast with a steel cabinet base, cast-iron top, split cast-iron fences, steel throat inserts and an induction motor.

A nice light-duty shaper (as defined by its 1½ horsepower motor and ½" to ¾" spindle size) is \$700 from Jet Tools. Grizzly offers one for \$425; Bridgewood's is \$495. These machines feature two speeds; a reversing induction (not universal) motor, which means it is extremely quiet; a



cast-iron top; and the cutters, mounted on the spindle, are easily adjusted up and down by turning a hand wheel on the front. Cutters are installed from the top and it can more safely handle larger-diameter cutters than the router.

Of course, what you can't do with a shaper is remove the motor for hand-held use like you can with a router.

When it comes to tooling, you can easily install a spindle in the shaper that uses ¼" and ½" collets, so you don't have to replace or double up on tooling with one kind for the shaper and another for the router. But you can buy shaper cutters that sometimes provide greater value than router bits. That's because many shaper cutters come with more than one profile. For example, one shaper cutter will have both a ¼" and ½" radius profile.

It's high time the once-popular shaper should get another look. And I promise you that in future issues we'll be acquainting you in more detail about this machine's many benefits for the home woodworker. **PW**

Steve Shanesy
Steve Shanesy,
editor and publisher

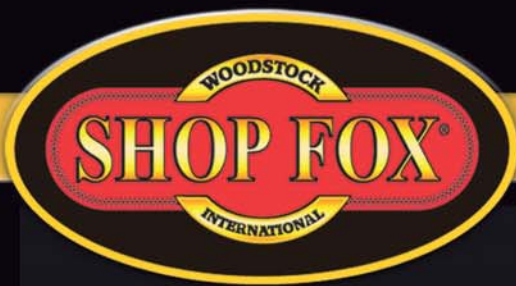

PRESENTING THE LONG AWAITED 10" LEFT-TILTING TABLE SAW

SEE THIS FINE MACHINE AT AN AUTHORIZED DEALER NEAR YOU!

NEW!

This saw will definitely take center stage in any shop. We've included two large precision ground cast iron wings, a jumbo miter gauge with a patented adjustment feature, and a powerful 3 H.P. motor with a triple belt drive system. The SHOP FOX® Classic Fence with a 26" rip capacity provides a compact and sturdy means for dependable and accurate ripping. (Longer rails are available.)

W1677
SHOP FOX®
3 HP Left-Tilting Table Saw



- LEFT-TILTING TABLE SAW**
- ◆ MOTOR: 3 H.P., SINGLE-PHASE, 220V
 - ◆ DRIVE: TRIPLE BELT
 - ◆ TABLE SIZE: 40 1/8" x 27" WITH WINGS (INCLUDED)
 - ◆ TABLE: PRECISION GROUND CAST IRON WITH T-SLOTS
 - ◆ ARBOR: 5/8" (CAN ACCEPT DADO SET AS WELL)
 - ◆ TABLE SAW INSERTS: 2 INCLUDED (STANDARD AND DADO)
 - ◆ MITER GAUGE: HEAVY-DUTY CAST-IRON
INCLUDES PATENTED ADJUSTABLE MITER BAR
 - ◆ SWITCH: HEAVY-DUTY MAGNETIC
 - ◆ MAX. BLADE HEIGHT: 3"
 - ◆ WEIGHS APPROX. 450 lbs.

2
YEAR
WARRANTY

403801958R

1-800-840-8420

Technical Support: 360-734-3482

sales@woodstockint.com

www.woodstockinternational.com

CALL TODAY FOR THE NAME OF A DEALER NEAR YOU



West Penn HARDWOODS, INC.

Satisfaction Guaranteed • No Minimum Orders
Quarter-Sawn White Oak • High Figure Curly Maple

Now Also Exotic Species:

Bloodwood, Bubinga, Jatoba, Spanish Cedar Padauk,
Purpleheart, Zebra wood and more

NEW: European Steamed Beech

ALL CREDIT CARDS ACCEPTED

Call for free catalog and pricing.

TOLL FREE (888) 636-WOOD (9663)

WHITECHAPEL LTD



THE WORLD'S FINEST HARDWARE
Free 216 page color catalog and reference: 1-307-739-9478
Web: whitechapel.ltd.com

CIRCLE NO. 121 ON FREE INFORMATION CARD.

4-WAY MONEY-MAKER!



- Molds
- Planes
- Sands
- Saws

Now, turn a \$5 rough board into \$75 worth of high-dollar molding in less than one minute! Make over 350 standard patterns, picture frame stock, any custom design. Quickly converts from **Planer/Molder** to **Drum Sander** or **Gang Rip Saw**! Choose from 12", 18" and 25" Models.

Variable Feed Makes The Difference!

Just a twist of the dial adjusts the Woodmaster from 70 to over 1,000 cuts per inch. Produces a glass-smooth finish on tricky grain patterns no other planer can handle. **Five Year Warranty. Prouder Than Ever To Be Made In America!**

FREE FACT KIT!

1-800-821-6651 ext. TP15

Woodmaster Tools, Inc. 1431 N. Topping Ave. Kansas City, MO 64120

LETTERS

Radial Arm Saw Users Speak Up

The Radial Arm Saw Actually Has Benefits Over the Table Saw

Your senior editor's comments on radial arm saws, although he did state that they were his opinions, makes me question whether he has ever used a radial arm saw (see Q & A, page 12, April 2002). My Sears radial arm saw has a kit added that makes it almost impossible to get your fingers near the saw blade.

My radial arm saw is equipped with an anti-kickback system that is always in effect during ripping. Can you say that for the table saw? With the radial arm saw you easily can see where the blade is relative to your cutline before starting your cut. Can you do that with the table saw?

With a table saw you always have to move the wood when cutting. On a radial arm saw you move the wood only when ripping.

As to the workable area of the tabletop, the table saw needs more area because you are always moving the workpiece. As to having an adjustable fence, this feature on a table saw has given rise to very expensive adjustable fence designs to keep from binding the wood when cutting. If your table saw doesn't have a good fence that keeps the wood parallel to the saw blade, the work can bind.

In addition, when crosscutting on the table saw, the wood is held perpendicular to the blade by only a very short fence. On the radial arm saw, it's located by a fence that runs the full length of the table plus any overhang built in. In addition, the rotation of the blade holds the work against the fence.

*Wilbert Freid
Sarasota, Florida*

Editor's note: We realize there are diehard radial arm saw users out there, but we continue to insist that for the home workshop, the table saw is a far safer, accurate and efficient machine. And in commercial woodworking shops, most radial arms saws are relegated to cross-cutting rough lumber.

Add Storage for Sheet Goods to the \$30 Lumber Rack

The "\$30 Lumber Rack" (April 2002, page 76) is a tremendous idea for wood storage. I like the ability to change the configuration of the rack at any time. In fact, I ran out and picked up the material right away so I could get my shop organized.

I ran my vertical supports from ceiling to floor. One suggestion I would like to make for others: Instead of placing the verticals on the wall, I spaced them about 7" from the wall. I bolted them to the joists above and the cement floor below using standard 90° brackets found in the building section of my local home supply store. I drilled into the floor using a hammer drill and used Tapcon threaded concrete screws to anchor the brackets. The 7" space behind is for sheet goods storage. Thanks again for a great, simple solution to wood storage.

*Michael Mathews
Jackson, Michigan*

Thicker Plane Irons Don't Always Work in All Hand Planes

After reading your article about tuning and using hand planes (April 2002, page 48), I have the following comment. I agree that buying an old relic plane and restoring it to a useable condition is both thrifty and rewarding.

continued on page 12

WRITE TO US

Popular Woodworking welcomes letters from readers with questions or comments about the magazine or woodworking in general. We try to respond to all correspondence. Published letters may be edited for length or style. All letters become the property of Popular Woodworking. How to send your letter:

- E-mail: popwood@fwpubs.com
- Fax: 513-531-0919
- Mail carrier:

Letters • Popular Woodworking
1507 Dana Ave., Cincinnati, OH 45207

Make Beautiful Raised Panel Doors...

with a 1/4" or 1/2" router, and 1/2" or 3/4" shaper.

Plus, make many other types of doors and projects with our carbide tipped, production quality Raised Panel Door Sets, including: Flat Panel Doors, Kitchen Cabinet Doors, Cathedral Doors, Glass Doors, Wainscotting, Entertainment Center Doors. Sets include Combination Rail and Stile bit, and Raised Panel bit. For our FREE tips and techniques manual order item #9069.

#1438 Raised Panel Door Video\$9.95

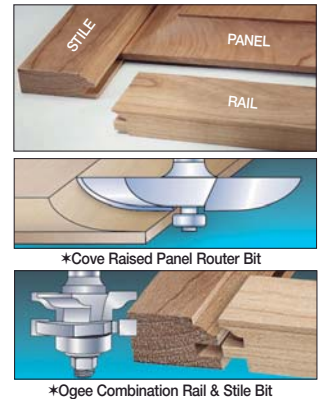

1/4" Shank Raised Panel Set

Carbide Tipped! Includes 2" dia. Cove Raised Panel bit with ball bearing and Ogee Combination Rail and Stile bit.

\$69⁹⁵
SET #1301

1/2" Shank Raised Panel Set

Carbide Tipped! Includes 3-1/2" dia. Cove Raised Panel bit with ball bearing and Ogee Combination Rail and Stile bit.

\$79⁹⁵
SET #1302

1/2" and 3/4" Shaper Set

Carbide Tipped! Includes 4-5/8" diameter Cove plus Ogee Combination Rail and Stile Shaper Cutters.

\$99⁹⁵
SET #1303

15 Piece Router Bit Set

MLCS Anniversary Set at a once-in-a-lifetime price!

Featuring these carbide tipped bits:

- 4 Straight (3/16", 1/4", 1/2", 3/4")
- 1 Cove (1/2")
- 1 Round Over (3/8")
- 1 Roman Ogee (5/32")
- 1 14° Dovetail (1/2")
- 1 Rabbeting (3/8")
- 1 Panel Pilot
- 1 45° Chamfer
- 1 Flush Trim (1/2")
- 1 Hinge Mortising (1/2")
- 1 Round Nose (1/4")
- 1 V-Groove (3/8")
- 1 allen wrench and 1 bearing to convert Round Over into Beading bit.



\$39⁹⁵
1/4" Shank • #1442
1/2" Shank • #1443

WOOD STORAGE BOX INCLUDED

30 Piece Router Bit Set

Celebrate our Anniversary by saving money!

Featuring these carbide tipped bits:

- 2 Cove (1/4", 3/8", 1/2")
- 2 Flush Trim (3/8", 1/2")
- 6 Round Over (1/8", 3/16", 1/4", 5/16", 3/8", 1/2")
- 5 Straight (1/4", 5/16", 3/8", 1/2", 3/4")
- 1 Chamfer (45°)
- 1 Slot Cutter (1/4")
- 1 Rabbeting (3/8")
- 1 V-Groove (1/2")
- 1 Bevel (25°)
- 1 Panel Pilot (3/8")
- 3 Round Nose (1/4", 3/8", 1/2")
- 3 Dovetail (14°-1/2", 5/8" & 9°-3/8")
- 2 Roman Ogee (5/32", 1/4")
- 1 Allen Wrench and 1 bearing to convert Round Over into Beading bit.



\$99⁹⁵
1/4" Shank • #1444
1/2" Shank • #1445

WOOD STORAGE BOX INCLUDED

66 Piece Router Bit Set

An amazing price for our most complete set!

- Includes the 30 Piece Set (left) plus these bits:
- Straight (7/16", 5/8", 1"), 1 Bevel (30°)
- 1 Groove Forming Classical (3/4"), 1 Keyhole (3/8")
- Hinge Mortising (1/2", 5/8", 3/4"), Classical Bit (3/16" r)
- 3 Core Box (1/4", 3/8", 1/2"), 1 Dish Cutter (1")
- V-Groove (3/8", 5/8"), Cove (1/8", 3/16", 5/16")
- Dovetail (7.5°-1/4", 14°-3/4"), Slot Cutter (3/8")
- 1 Point Cutting Round Over (1/2")
- 1 Flat Bottom Round Over (1/4" r)
- 1 Multi Bead/Reed Bit (1/8" r)
- 1 Double Round Over (5/32" r)
- 1 Cove Sign Lettering (5/8" 60°)
- Chamfer (30°, 22.5°, 15°)
- 4 bearings & allen wrench



\$224⁹⁵
1/4" Shank • #1446
1/2" Shank • #1447

WOOD STORAGE BOX INCLUDED

Safety Small Parts Holder

Eliminate danger when working with small parts. Securely positions and aligns small parts with quick release clamping action, preventing slipping and keeping fingers away from sharp cutting edges. Large, easy-to-grip handles guarantee precision and control when custom-shaping small pieces. Handles wood stock up to 10" and any cut angle up to 45 degrees. Works for router or saw tables, drill presses, band saws, joiners and more. Great for toy parts, door rail ends, and other detail jobs that would be dangerous or impossible without it.



\$19⁹⁵
ITEM #1451

6 Piece Cabinetmaker Router Bit Set

1/2" shank Carbide Tipped set. Make kitchen cabinets, raised panel doors, table tops and drawers. For up to 3/4" wood. Includes these bits:

- Glue Joint (1-3/4")
- Drawer Lock (1-3/4")
- Rail & Stile Matched Pair (1-5/8")
- Ogee Raised Panel (2-3/4")
- Round Over & Ogee Door Lip (1-1/4")



\$114⁹⁵
SET #1452

WOOD STORAGE BOX INCLUDED

16 Piece Forstner Bit Set

Includes these sizes:
1/4", 3/8", 1/2", 5/8", 3/4", 7/8", 1", 1-1/8", 1-1/4", 1-3/8", 1-1/2", 1-5/8", 1-3/4", 1-7/8", 2", 2-1/8".



\$43⁹⁵
SET #1418

WOOD STORAGE BOX INCLUDED

1-800-533-9298

FREE CATALOG • Order securely online at:
mlcswoodworking.com

MLCS
ROUTER BITS AND PROFESSIONAL WOODWORKING PRODUCTS

CIRCLE NO. 115 ON FREE INFORMATION CARD.

FREE Shipping!

IN CONTIGUOUS USA FOR ALL ITEMS



MLCS, P.O. Box 4053PC, Rydal, PA 19046

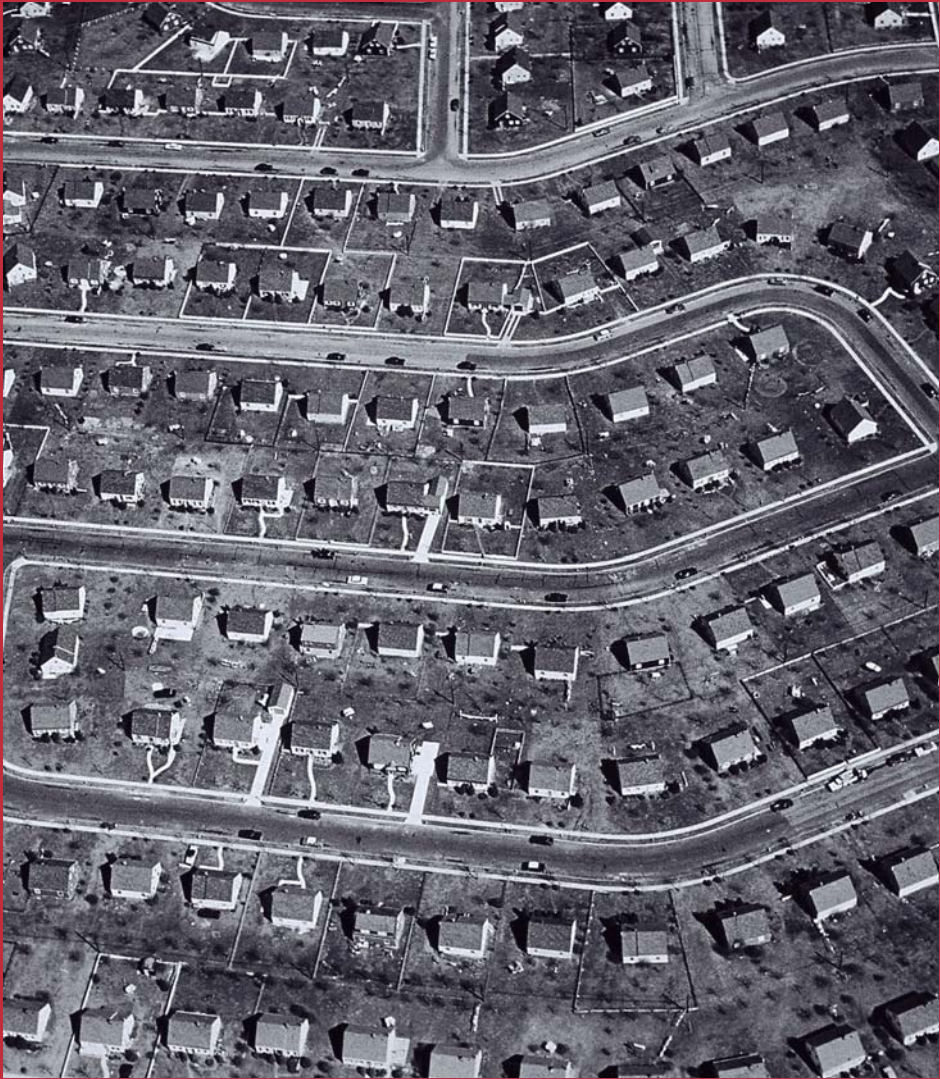



*10-inch Table Saw
with Align-A-Rip XRC.
For a consistent
cut every time.*

In the '50s and '60s, suburbs started springing up all

over America. And Craftsman® tools were

there. Pounding in nails. Tightening screws.

Sawing boards. However, there was one piece of equipment that

wasn't available back then. But considering the suburbs' zest for uniformity, it would have

come in handy. It's the new Professional Heavy-Duty 10-inch Table Saw. While it has all the

CRAFTSMAN HELPED BUILD THE SUBURBS. SO WE KNOW A THING OR TWO ABOUT UNIFORMITY.

innovations you'd expect — like easy-to-read scales — its most exciting feature has to be

the Align-A-Rip XRC™. It's a quick-release rip fence with rack-and-pinion microadjustment

setups. In plain English, that means it allows you to quickly cut the size of board you need.

Then continue to cut that exact same size. Again and again. The Professional 10-inch Table

Saw — available at Sears. It's sure to come in handy

around your house. Even if you don't live in the 'burbs.

CRAFTSMAN®
75th ANNIVERSARY

C E L E B R A T I N G 7 5 Y E A R S O F M A K I N G A N Y T H I N G P O S S I B L E .

THE STANDARD IN SANDERS



Clayton Spindle Sanders are built in the USA with precision balanced spindles, oversized bearings, and a premium Baldor Induction Motor.

- Benchtop and full-sized, professional models
- Large table surface
- Built-in dust port
- Quick-change drums

Clayton tackles the toughest sanding jobs...smoothly.
FREE COLOR CATALOG, call: 1-800-971-5050

CLAYTON
Spindle Sanders

CLAYTON MACHINE CORP.

ROYAL OAK, MI 48068-0520

CIRCLE NO. 102 ON FREE INFORMATION CARD.

LETTERS

continued from page 8

You mentioned that a Stanley Type 11 jack plane is the best bang for the buck and that equipping this relic with a Hock iron will increase the performance of this jewel. Caution! I'm not familiar with the mouth of the Type 11, but the mouth on my No. 5 jack and No. 7 jointer planes is a mere $\frac{5}{32}$ ". On my No. 5 the bed angle of my frog is at 45° and with the Hock iron installed there's a scant 0.02" (less than $\frac{1}{32}$ ") for the shaving to pass. On planes with a lower bed angle, the mouth opening needs to be even larger.

I'm not a purist with regards to ensuring that my planes are not used to maintain their value, but I would dread using a flat file to open the mouth to accommodate a plane iron that I paid about the same price for as my No. 5 from the antique mall. Also, these thicker irons claim to and probably do hold an edge longer because of their hardness of Rc60 or better. Blade hardness is a two-way street. The harder the steel the longer it takes to hone (or worse, remove a nick in the micro-bevel). The harder irons are better ground on a grinder such as a Tormek unit, which is out of my and most woodworker's budgets.

I almost purchased a thicker iron for my No. 5 because there is slight pitting on the face of the iron. By fortune I had my No. 5 with me in the big city and tried to fit a Hock iron in it only to find out what I explained above. Needless to say I kept the iron with "character" and have enjoyed good planing ever since – and saved \$35 to boot.

Tom Normington
Athens, Wisconsin

Editor's note: You raise a good point. I've only run into the problem with the Clifton aftermarket irons (which are even thicker at .116") but there are some plane mouths that simply are too small to accept thicker irons. The Type 11 planes we recommended work fine with a Hock. I've restored four of these planes, and the Hock has always had plenty of room. However, if you're looking to upgrade a plane with an aftermarket iron, try the iron in the plane body before you buy it (or make sure you can return it to the catalog company).

One last note, I've never found sharpening Hock irons to be difficult and have flat ground them on my sharpening stones for years. PW

— Christopher Schwarz, senior editor

ARROW
*Select the right tool
...get the job done right*



Build a Picture Frame



Upholster a Chair

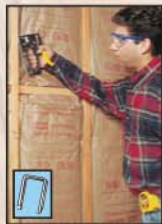

Install Insulation



Shoots 6 different size staples & 5/8" brad nails, too.



T50°PBN
MADE IN USA
HECHO EN E.U.A.

There are so many jobs the versatile ARROW T50°PBN Staple + Nail Gun can do.

It shoots 6 different size staples and also drives a 5/8" brad nail. Thanks to its "Easy Squeeze Double Leverage Mechanism" and cushioned grip, this tool is a breeze to use.

And, because of its all-steel construction with carbon hardened steel working parts, the rugged T50°PBN will be a reliable member of your tool box for many years to come.

ARROW tools and supplies are available at home centers, lumberyards and hardware stores.

U.S.A.: Arrow Fastener Company, Inc., 271 Mayhill Street, Saddle Brook, N.J. 07663
United Kingdom: Arrow Fastener (U.K.) Ltd., 14 Barclay Road, Croydon, Surrey CR0 1JN
Canada: Jardel Distributors, Inc., 6505 Metropolitan Blvd. East, Montreal, Quebec H1P 1X9
www.arrowfastener.com

© 2001 ARROW FASTENER CO., INC.

CIRCLE NO. 101 ON FREE INFORMATION CARD.

Actor Dan Haggerty,
Star of "Grizzly Adams".

Grizzly Industrial, Inc.®

Introducing the New Grizzly Pro™ Series of Nailguns & Staplers

Sleek ergonomic design and more power than ever!

*"I love dealing with Grizzly Industrial.
They have excellent products and stand
behind everything they sell."*

Dan Haggerty

All Professional Series Nailgun
Kits include oiler, hex wrenches,
goggles and a supply of staples
or nails encased in a heavy-duty
Grizzly carrying case.



H2911 Grizzly Pro Nailer



- 18 Gauge Nailer, shoots 5/8" - 2" 18 gauge brads.
- 1-Pc. type driver made of SKD61 steel that guarantees at least 400,000-shot performance.
- Most powerful 18 GA nailer in its class.
- Unique 6-position depth adjustment. 360° exhaust port.
- Kit includes oiler, goggles, hex wrenches, 1000-Pc. of 2" brads in a Grizzly case.

Performance
400,000 SHOTS!
Guaranteed!

Introductory
Price
\$109⁹⁵

H2912 Grizzly Pro 2-in-1 Nailer/Stapler



- 2-in-1 Nailer/Stapler, shoots 5/16" - 1/4" 18 gauge staples and 3/8" - 1/4" 18 gauge brads.
- Single-shot/Bump-fire switch mode, unique 6-position depth adjustment, 360° exhaust port.
- Kit includes oiler, goggles, hex wrenches, 400-Pc. of 1" staples, 400-Pc. of 1/4" staples, 1000-Pc. of 1" brads and 1000-Pc. of 1/4" brads in a Grizzly case.

Performance
200,000 SHOTS!
Guaranteed!

Introductory
Price
\$109⁹⁵

H2909 Grizzly Pro Stapler



- 18 Gauge Stapler that shoots 3/8" - 1/16" staples
- 1-Pc. type driver made of SKD61 steel
- Unique 6-position depth adjustment.
- 360° exhaust port, 100-Pc. capacity magazine, instant jam clearing without releasing the nose piece (just by opening the bottom loading magazine).
- Kit includes oiler, hex wrenches, goggles & 1000-Pc. of 1/2" staples in a Grizzly case.

Performance
400,000 SHOTS!
Guaranteed!

Introductory
Price
\$139⁹⁵

H2910 Grizzly Pro 3-in-1 Nailer



- 16 Gauge 3-in-1 wood, metal & concrete nailer, shoots 1/16" - 2" 16 GA nails and 1.83mm diameter steel concrete nails up to 1".
- 1-Pc. type driver made of SKD 61 steel
- Most durable tool in its class.
- Unique 6-position depth adjustment. 360° exhaust port.
- Most affordable, powerful & versatile tool in its class.
- Kit includes oiler, goggles, hex wrenches, 225-Pc. of 3/4" steel concrete nails, 500-Pc. of 16 GA x 1 1/2" nails and 500-Pc. of 16 GA x 2" nails in a Grizzly case.

Performance
400,000 SHOTS!
Guaranteed!

Introductory
Price
\$149⁹⁵

H2913 Grizzly Pro 2-in-1 Nailer/Stapler



- 2-in-1 Nailer/Stapler, shoots 5/16" - 1/16" 18 gauge staples & 3/8" - 2" 18 GA brads.
- Single-shot/Bump fire switch mode, unique 6-position depth adjustment, 360° exhaust port.
- Kit includes oiler, goggles, hex wrenches, 400-Pc. of 1" staples and 1000-Pc. of 2" brads in a Grizzly case.

Performance
200,000 SHOTS!
Guaranteed!

Introductory
Price
\$149⁹⁵

VISA MasterCard Discover
MEDIA CODE
A01368
400101658R2

CALL TODAY FOR A
FREE 468 PAGE
COLOR CATALOG

1-800-523-4777

Customer Service: (570)546-9663 FAX: (800)438-5901

OVER 11,000 PRODUCTS
AVAILABLE ONLINE!

grizzly.com

RECEIVE A FREE GIFT WITH EVERY
ONLINE ORDER (LIMITED TIME OFFER)

Swage Butt Hinges for Tighter-fitting Cabinet Doors



Not swaged

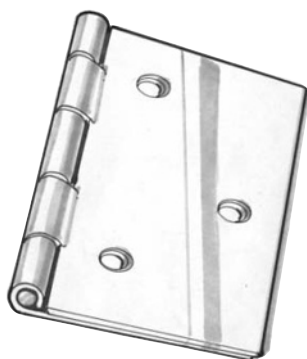

Fully swaged

Illustration by Hayes Shanesy

A Vise or a Hammer is All You Need to Help Your Doors Fit Better

When I install butt hinges on cabinet doors I get much too large a gap, sometimes more than $\frac{1}{8}$ " , when I mortise just as deep as the hinge leaf is thick. Then I have to cut the mortise deeper, but this doesn't look right and can lead to the door binding against the stile if I cut too deep. What's the right way to do this so you get it right every time?

Edward Bell
Lawrenceburg, Georgia

Because one benchmark of a well-made cabinet is a small margin, or gap, around the door and drawer openings, woodworkers want to get this right. A good standard to shoot for is a dime, or $\frac{1}{16}$ " space, on all sides. Even the most careful cutting to size won't give you the right margin on doors if the hinge isn't properly mortised.

One excellent solution to achieving the right gap is to make sure your hinges are "swaged," which means they have had the leaves partially or fully bent at the barrel so they are closer together when the leaves are parallel to each other. When swaged, all you need to do is rout or chisel the hinge leaf mortise to the thickness of the leaf. That way, the hinge itself will establish the correct gap along that side of the door.

Some butt hinges come swaged. But it's easy to do yourself. Either press the leaves together in a strong metalworking vise or place the hinge on a solid surface, align a piece of heavy steel ($\frac{1}{4}$ "-thick) right along the barrel, then give it a good whack with a heavy hammer.

— Steve Shanesy, editor and publisher

How Much Variation Should There Be in the Size of Router Bits?

I've been organizing my router bit drawer with new ones purchased from several manufacturers. Because most weren't marked on the shanks with the nominal size they represent, I used two different sets of micronic calipers to measure the diameter of each straight bit through its full circle.

What I find is a variation from the stated size, sometimes up to .012". For example, a straight-cut bit I had that was a $\frac{3}{4}$ " (.750"), measured .739". This bit had not been used yet, so I couldn't blame it on wear.

I found this same scenario true on other sizes. By the way, these were not the smaller-diameter bits for plywood; I keep them separate from my other bits.

What, in your opinion, is the acceptable tolerance from nominal that makes the bit saleable? Is there an industry standard, or do

suppliers just make them and sell them if they're close enough?

I admit I'm a perfectionist at times, but then again, "fine woodworking" is in many instances about paying attention to the finer points of the craft.

Jeff Badman
via the internet

Jim Brewer at Freud Inc., responds:

"Like anything in the market, you have different quality levels, including the tolerances a manufacturer holds on its product. I cannot speak for other manufacturers but can speak to Freud's tolerances.

"The cutting-diameter tolerance varies based on the critical dimension of the bit. An example of this is a straight bit. It would have a tight tolerance because of the critical need to cut a slot of a given width. A profile bit may be less critical on the outside diameter and could have a tolerance that was a little wider. One could reason, 'Why not hold a very tight tolerance on every bit?' Doing so would increase the cost of the bit without any benefit to the consumer.

"Freud generally holds tolerances on outside diameters ranging from $\pm .002$ to $\pm .0008$. Other quality manufacturers may hold tolerances similar to this, but as you go down the price scale, you will find the tolerances get much wider."

What Computer-aided Design (CAD) Software is Good For Woodworkers?

I am wondering if there might be some software to aid in designing home furniture. Any help would be appreciated.

Bill Adams
via the internet

There are lots of software programs in all price ranges that can help. Most sorts of CAD software designed for architectural work also work well for designing furniture — it's simply drawing boxes on a considerably smaller scale.

If you're just starting out, we recommend QuickCAD (about \$70), which is made by Autodesk, the industry standard in the architectural world. QuickCAD will not draw 3D images, but it handles two-dimensional construction drawings beautifully.

Another advantage to these software packages is that you can easily make optimization charts for your lumber and plywood. After you

continued on page 16

www.osbornewood.com
OSBORNE
 Wood Products, Inc.

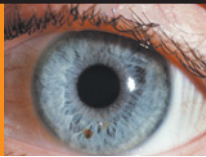

We've got an eye... for Table Legs

We have Table Legs . . . and plenty of them. From simple to ornate, from dainty to robust, we just might have what you're looking for in Pine, Maple, Oak, or Cherry. And if we don't, we can custom-make table legs to your specifications!



8116 Highway 123 North • Toccoa, GA 30577
 Call for a catalog: 1-800-746-3233 • 706-886-1065
 Order line: 1-800-849-8876 • Español: 1-877-445-6034

CIRCLE NO. 117 ON FREE INFORMATION CARD.

ProMax[®] Deck Screws
from the Source

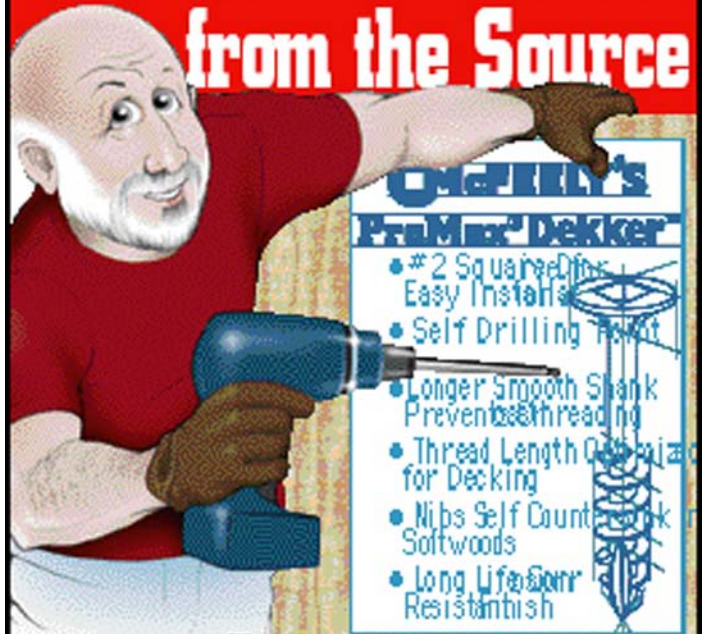

- McFEELY'S**
ProMax[®] Decker
- #2 Square Drive
 - Easy Installation
 - Self Drilling Point
 - Longer Smooth Shank Prevents Splitting
 - Thread Length Optimized for Decking
 - Nibs Self Countersink Softwoods
 - Long Life Serr Resistant

Write for
FREE
 Catalog

McFEELY'S
 SPECIALTY LUMBER SCREWS

PO Box 11169 • Dept PWEC • Lynchburg • VA • 24506
 Toll Free 1-800-443-7937 or at www.mcfelys.com

CIRCLE NO. 114 ON FREE INFORMATION CARD.

THE WORLD'S BEST ROUTER JOINERY JIGS BY LEIGH



The Rout Stuff.



Router not included

D4 Dovetail Features:

- Infinite spacing of pins and tails
- Through dovetails up to 1 1/4" thick
- Half-blind dovetails up to 1 1/2" thick
- Sliding dovetails up to 1 1/2" thick
- All three can be cut in boards up to 24" wide
- Imperial or metric measurement scales

Comes standard with:

- Two cutters for 1/2" to 3/4" through dovetails
- 168-page fully illustrated User Guide
- D4 Dovetail Jig Instructional Video
- Cam-Action Speed-Clamps
- Adjustable side stop for angled dovetails

Leigh Joinery Jigs have it all. Hobbyist or professional, the Leigh D4 Dovetail Jig will ensure you create your best work. Versatility, precision and superb value make the Leigh Dovetail Jig better than the rest. Rout through and half-blind dovetails, with variable spacing of pins and tails, on one jig. Create decorative Isoloc joints, finger joints, and multiple mortise & tenons effortlessly with Leigh attachments and our exceptional user guides! Get the right stuff for the job. Call toll free now!

Call For Your FREE Leigh Catalog Today! 1-800-663-8932

LEIGH
 Joining Tradition With Today

Leigh Industries Ltd., PO Box 357
 Port Coquitlam, BC Canada V3C 4K6
 Toll free 1-800-663-8932 Tel. 604 464-2700
 Fax 604 464-7404 Web www.leighjigs.com

WOODLINE ARIZONA, INC. OFFERS YOU MORE...

Super Sets AT Great Prices!!!

30-Piece Professional Set



- Includes:
 5 Straight bits
 3 Dovetail bits
 3 Core Bits
 3 Cove Bits
 6 Roundovers
 2 Flush Trim
 1 Panel Bit
 2 Roman Ogee
 2 Slot Cutters
 1 "V" Groove
 1 Chamfer
 1 Bevel Trim Bit

WL-2010 OUR PRICE ONLY \$109 set



- 5-Piece Cove Set
 1/2" Shank Router Bits
 1/4"R, 3/8"R, 1/2"R,
 5/8"R, 3/4"R

WL-2015 OUR PRICE ONLY \$49 set

5-Piece Roundnose (Core Box) Set



- 1/2" Shank Router Bits
 3/8"D, 1/2"D, 3/4"D, 1"D, 1 1/2"D

WL-2012 OUR PRICE ONLY \$49 set

13-Piece Dovetail Set



- 1/2" Shank Router Bits
 3 Straight bits
 10 Dovetail bits

WL-2014 OUR PRICE ONLY \$49 set



- 6-Piece Bullnose Set
 1/2" Shank Router Bits
 1/4"D, 3/8"D, 1/2"D,
 5/8"D, 3/4"D, 1"D

WL-2013 OUR PRICE ONLY \$89 set

3-Piece Cabinet Door Set



- 1/2" Shank Router Bits
 2-Piece Roman Ogee Rail & Stile
 2 3/4" Ogee Panel Raiser

WL-2019 OUR PRICE ONLY \$65 set

15-Piece 1/2" Shank Set



- Includes:
 Chamfer
 Cove -
 1/2"R, 3/8"R, 1/4"R
 Roundover -
 1/2"R, 3/8"R, 1/4"R
 Roman Ogee -
 1/4"R
 Straight Bits -
 3/4"R, 1/2"R, 1/4"R
 Roundover -
 1/2"R, 3/8"R, 1/4"R
 1/2" Dovetail
 1/2" Roundover
 1"CL Flush Trim
 Rabbet Bit

WL-2022 OUR PRICE ONLY \$59 set

15-Piece 1/4" Shank Set
 same as WL-2022 except 1/4" shank
 WL-2021 OUR PRICE ONLY \$59 set

5-Piece Cabinet Door Set



- Includes:
 3/4" Bore Shaper Cutter
 1-pc Rail & Stile (Roman Ogee)
 4 5/8" Panel Raiser (Ogee)
 Door Lip
 Glue Joint
 Drawer Locker

WL-1505 OUR PRICE ONLY \$179 set

6-Piece Cabinet Door Set



- Includes:
 2-pc Rail & Stile
 (Roman Ogee)
 2 3/4" D Panel
 Raiser (Ogee)
 Door Lip
 Glue Joint
 Drawer Locker

WL-2020 OUR PRICE ONLY \$119 set

8-Piece Classical Set



- Includes:
 2 Classical - 5/32"R & 1/4"R, 1 Wavy
 2 Ogee - 5/32"R & 1/4"R, 1 Fillet
 2 Roman Ogee - 5/32"R & 1/4"R
 (1/2" Shank Router Bits)

WL-2016 OUR PRICE ONLY \$99 set



- 5-Piece Moulding Set
 1/2" Shank Router Bits

WL-2011 OUR PRICE ONLY \$99 set

All Woodline Arizona Sets are packaged in a beautiful wood box (a \$10.00 value).



- 5-Piece Carbide-Tipped Forstner Bit Set
 3/8" Shank for Drill Press
 35mm, 1 1/4", 1", 3/4", 5/8"

WL-2018 OUR PRICE ONLY \$39 set



- 5-Piece Dovetail Set
 1/2" Shank Router Bits
 8" - 1/2"
 14" - 3/8", 1/2", 5/8", 3/4"

WL-2017 OUR PRICE ONLY \$19 set

Q & A

continued from page 14

draw a cabinet, you can drag the parts onto a drawing of your lumber (or your plywood) and move them around to get the best yield.

— Christopher Schwarz, senior editor

Should I Be Worried About Wood Movement With Solid-wood Facing?

I am planning to build bookcases, 7' high by 4' wide and 1' deep using 3/4" oak plywood and 3/4" oak solid-wood facing on the edges of the sides and shelf facings. My question is whether I can safely glue the facing to the plywood without fear of expansion and contraction of the solid wood.

Art Daniel
via the internet

You have absolutely nothing to be concerned about with regard to the solid-oak facings on your plywood edges. The solid lumber is simply not wide enough to expand or contract with noticeable movement.

You might want to give some further thought to the 4' shelf length if you plan to load them down with books or other heavy objects. The shelves could sag some, especially if they are adjustable and therefore not supported along their back edge. Any length past 36" on 3/4" ply that will see real weight is prone to sag. Some cabinetmakers would say that any length beyond 30" risks some sagging.

— Steve Shanesy, editor and publisher

Does a Damaged Lever Cap on a Plane Hurt its Performance?

When my father passed away I kept his jack plane. It is a Bailey No. 5. After sharpening the plane iron I noticed the lever cap must have been used to adjust the frog screw or lever cap screw. Two spots were knocked out of the left bottom side. Is this a bad problem? Can or should I try and replace the lever cap?

James Lissner
Bellevue, Washington

Damage to the lever cap isn't as much a problem as damage to the chipbreaker (another problem on older planes). The main job of the lever cap is to hold the blade and chipbreaker assembly tightly against the frog. Its role in removing shavings is minimal.

However, if the damage is severe, it can interfere with the removal of your plane's shavings or even compress the chipbreaker and blade



WOODLINE ARIZONA, Inc.
 P.O. Box 298 • Temecula, CA 92593
 Great Router Bits & Shaper Cutters!
 Best Selection...Best Price

Order Toll Free

1-800-472-6950

Get your FREE catalog and see our great selection of Bits and Cutters

Most items in stock • All major credit cards accepted
 Same-day shipping!! • Shipping \$3.75/\$100 + \$4.75

WOODLINE's Quality Bits and Cutters feature:

- Tough Micro-Grain Carbide
- Euro Anti-Kickback Design
- Super-slick Non-stick finish

• Super Low Prices

Check our website for new products:
www.woodbits.com

CIRCLE NO. 124 ON FREE INFORMATION CARD.

assembly unevenly. I would look at the lower edge of your lever cap and make sure it is smooth and contacts the chipbreaker all the way across its width. If you'd like to replace your lever cap, Woodcraft Supply (800-225-1153 or www.woodcraft.com) and Highland Hardware (800-241-6748 or www.highlandhardware.com) both carry replacement parts for most Bailey-style planes. A new lever cap will cost about \$21.

— Christopher Schwarz, senior editor

How Do You Get the Grain in Baltic Birch Plywood to Pop?

How does one get the grain in Baltic birch plywood to show to good advantage? I would like to get the grain to show darker against the lighter wood. This plywood has wonderful structural properties and the grain is there, but I cannot get it to pop out. Heavy sanding seems to help. I also have tried clear oils and finishes without success.

Commercial stains don't penetrate enough to do the job. They end up more like a thin paint. I have tried Danish oil, linseed oil, nitrocellulose lacquer, polyurethane and many commercial stain sealers. The best I've found so far is Minwax Ebony, but there is still much room for improvement.

Joe Doyle
via the internet

Adding color to Baltic birch is a problem. First, birch is one of those stubborn woods that will blotch when stained. It's in the same blotch-prone family as pine, cherry and maple. Additionally, the color of the birch facing is uniform, so there are no dark/light color variations that will be highlighted by stains or dyes. Furthermore, the grain is tight, so pigmented stains find no room to collect in the tiny grain pores, as is the case with oak and other coarse-grained woods.

However, I have had some success using aniline dye on Baltic birch. There's less of a problem with blotching because the dye penetrates the wood fibers, rather than lying on top of the wood. And because there is no pigment, the dye doesn't cover up what little grain there is to show.

You might enhance your results with the dye by following it up with a light application of linseed oil. I often have applied linseed oil to figured woods such as curly or bird's eye maple to deepen the contrast where the grain changes direction. It's worth a shot. **PW**

— Steve Shanesy, editor and publisher

For a dirt & dust free finish GET IT ALL

with Datco
Surgical Blue™
& Professional™
Tack Cloth



Call 1-800-TACKRAG
or order online at www.tackcloth.com

CIRCLE NO. 103 ON FREE INFORMATION CARD.

NIAGARA LUMBER

You'll appreciate our difference.

Prepaid Freight • Surfaced • Bundled
Shrink Wrapped • Guaranteed

- All lumber is Select and better grade, 4" and wider, averaging 6"-7" in width, lengths are 6'-8". All stock meets or exceeds National Hardwood Lumber Assoc. grade rules.
- All domestic lumber is Northern Appalachian grown, exhibiting characteristics of fine grain, texture and uniform color.

Visa/Mastercard/Discover accepted.

Niagara Lumber

& WOOD PRODUCTS, INC.
47 Elm Street • East Aurora, NY 14052
Call Toll-Free 1-800-274-0397
www.niagaralumber.com

CIRCLE NO. 126 ON FREE INFORMATION CARD.

Adams Wood Products
LTD., L.P.

STOCK ITEMS
NO MINIMUM ORDERS
-OR-

WE WILL MAKE PRODUCTION RUNS OF YOUR PART

Made in Tennessee
By American Craftsmen

CHAIR LEGS
ACR08
AMD08

BUN LEGS
A0556

FR STYLE QUEEN ANNE LEGS

FINIALS
A0851

113 REEDED BASE W/206 LEG

404 CHAIR KITS

P.O. Box 728, Dept. PW17
Morristown, TN 37815-0728
Phone 423-587-2942 • Fax 423-586-2188
www.adamswoodproducts.com **FREE COLOR CATALOG**

CIRCLE NO. 100 ON FREE INFORMATION CARD.

Nobody But Bessey Has Ever Designed and Built a Clamp That Works Like a K-Body Clamp ... Nobody.

The original parallel clamp designed for woodworkers who depend on accurate clamping every time they use their K-Body, year after year.

The original Bessey K-Body ... for woodworkers who believe "almost" parallel, is just not good enough.



ISO 9001 CERTIFIED

www.americanclamping.com

CIRCLE NO. 141 ON FREE INFORMATION CARD.

The Toughest Glue On Planet Earth

Gorilla Brand Premium Glue is the all purpose, interior/exterior glue ideal for most repair and bonding needs. It's great for indoor/outdoor furniture repair, woodworking projects, as well as general repairs around the house. Bonds wood, stone, metal, ceramic plastics and more! Incredibly strong and 100% waterproof.



for retailers near you:
www.gorillaglu.com
1-800-966-3458

CIRCLE NO. 113 ON FREE INFORMATION CARD.

TRICKS OF THE TRADE

Thumb-saving Push Stick

THE WINNER:

The push stick has been around for a long time, making table saw work safer. There are many types, but I came across a variation a while back that made so much sense I had to share it. By simply taking a traditional push stick (I use a two-sided version to work with different thickness material) and screwing a poplar block to the center, I made it even safer. The added block keeps your thumb from accidentally slipping toward the blade.

Make sure you keep at least 1" of clearance between the blade and the thumb guard at all times, to make sure you don't accidentally rock the push stick into the blade. You can easily adjust the size and shape of this push stick to match your preferred style, but adding a simple thumb rest makes me more comfortable when working on the table saw.

Ron Martin
Sunman, Indiana

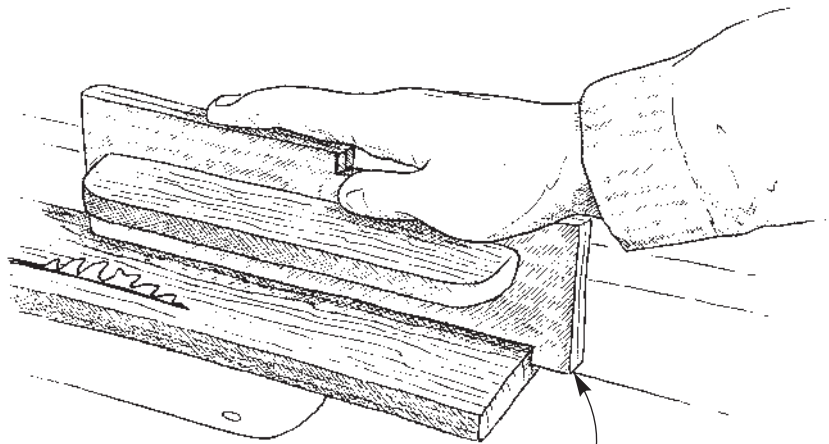

Overall dimensions: 3/4" x 5" x 10"

Illustrations by John McCormick.

continued on page 20

CASH AND PRIZES FOR YOUR TRICKS AND TIPS!



Each issue we publish woodworking tips and tricks from our readers that we think are useful. We want to encourage you to share with your fellow woodworkers, as well as reward the most useful and original concepts. Delta has agreed to lend us a hand with that, and the author of this issue's winning trick receives the new 22-580 two-speed portable thickness finishing planer (shown at left). The other trick's authors receive a check for \$75.

To submit your tip or trick, e-mail it along with a daytime phone number to david.thiel@fwpubs.com or mail it to:

Tricks of the Trade • Popular Woodworking
1507 Dana Ave.
Cincinnati, OH 45207

 **DELTA**
MACHINERY

WOODWORKERS BEWARE!

Your blades are in danger!

The **WIZARD** line of metal detectors can help prevent costly planer, jointer, and saw blade damage from nails, screws, or other metal hidden inside your lumber. Designed especially for woodworkers, all include a 1 year warranty.



Little Wizard \$19.95*

- Economical
- 2" scanning coil
- Effective to 2" deep



Lumber Wizard \$99.95*

- 6" scanning coil
- Faster Scanning
- Effective to 4" deep
- Vibration Alert - Allows use in noisy workshops



Wood Scan Wizard \$99.95*

- Fastest Scanning
- Scan up to 6"x12"x any length
- Scan all 4 sides of lumber at once
- Effective to 4" deep
- Use hand-held or in benchtop stand



Call to find a dealer near you, or visit us on the web:

WIZARD™ Detectors - 888-346-3826

<http://WizardDetectors.com>

*Recommended Retail Price

Dealer Inquiries Welcome!

CIRCLE NO. 128 ON FREE INFORMATION CARD.

NEW!

The Leigh FMT Mortise and Tenon Jig



Finally a jig designed to create mortise and tenons in one quick easy setup!

FMT features:

- Unique patented guide system
- Joints of any size from 1/2" x 5" down to a tiny 1/16" x 3/32"
- Use on matches or stock up to 3" x 5 1/2" (mortise) and 2 3/4" x 5 1/2" (tenon)
- Easy fingertip adjustment of joint tightness
- Make angled and compound angled joints
- Rout perfectly aligned double, triple and quadruple joints
- Use virtually any plunge router
- Uses 1/2" shank cutters
- Cam-action speed-clamps
- Integral dust port for vacuum

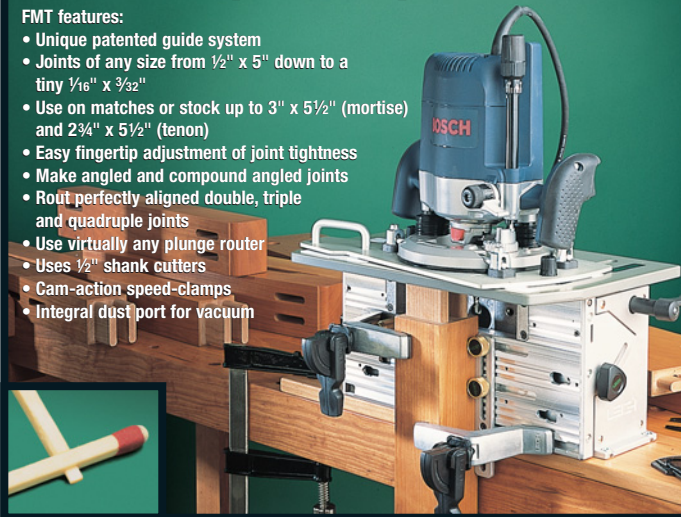

Call For Your Free Leigh FMT Brochure Today! 1-800-663-8932
Leigh Industries Ltd., PO Box 357, Port Coquitlam, BC, Canada V3C 4K6
Tel. 604 464-2700 Fax 604 464-7404 Web www.leighjigs.com

LEIGH
Joining Tradition With Today

SUPERSHOP 10-IN-1 WOOD & METAL SHOP

BECOME A BETTER WOODWORKER - **GUARANTEED!**

You'll make projects with higher **QUALITY, PRECISION, SPEED & SKILL!**



SuperShop will increase your woodworking skills or **WE'LL BUY IT BACK!**

- New, different & BETTER than "look-a-like" machines
- 10 most-used tools in 1 for ultimate versatility
- Rock-solid 450 lbs., 2.5 times MORE than others
- State-of-the-art **ELECTRONIC** speed controls
- Extra **POWER-IN-RESERVE** DC motor
- 30-Day **RISK FREE** Buy-Back Offer & industry-leading Warranty



Get your **FREE SUPERSHOP REPORT - "Better Woodworking GUARANTEED!"**

CALL TOLL FREE **1-800-476-4849**

Or this Mail to: **SuperShop** Dept. PWV, P.O. Box 1517, Ann Arbor, MI 48106

YES! Tell me how SuperShop will increase my craftsmanship. Rush facts, specs, and **CURRENT SALE OFFER!**

Name _____
Address _____
City _____ State _____ Zip _____

CIRCLE NO. 120 ON FREE INFORMATION CARD.

Veritas® Low-Angle Smooth Plane

The newest in our series, the Veritas low-angle smooth plane has all the advantages of our low-angle block with the added benefit of a full-size bench plane footprint. It is excellent for end-grain work, smoothing large surfaces and, with the large side wings, is ideal for shooting miters. Features an adjustable mouth, a 2" A2 tool steel blade and a body cast from ductile iron. If you have never owned a low-angle smooth, you will find it a delight to use and immediately one of your favorite planes. **05P25.01 \$139.00**

Shipping and N.Y. sales tax extra.

Lee Valley
veritas®

Lee Valley Tools Ltd.
12 East River Street
Ogdensburg, N.Y. 13669

For more information or to request a catalog, contact us at:

1-800-871-8158

or customerservice@leevalley.com

Shop online: www.leevalley.com



continued from page 18

Rust-proof Storage from the \$1 Store

I bought a coping saw, but I didn't think to buy something to store the extra blades in. While pointing out my oversight to my wife, she remarked that I could use one of those round toothbrush holders you use when traveling. They cost next to nothing for a pack of three, and you can get them at lots of stores. These tubes are long and fat enough to hold scroll saw blades, too. I've tried some of the tubes you can buy from woodworking catalogs, but after two weeks in a heavily used drawer, the tubes were without tops and the blades were rusting. The toothbrush

holder is going strong after months of rolling around in the same drawer. I also put a cotton ball wetted with Campho-phenique in one end. I have no idea if the camphor actually coats the blades to prevent rust or if the vapors alone displace the oxygen to keep the rust at bay. Either way, I've decided to add a wetted cotton ball to all my containers that hold my precious metals.

David Grundvig
Napa, California

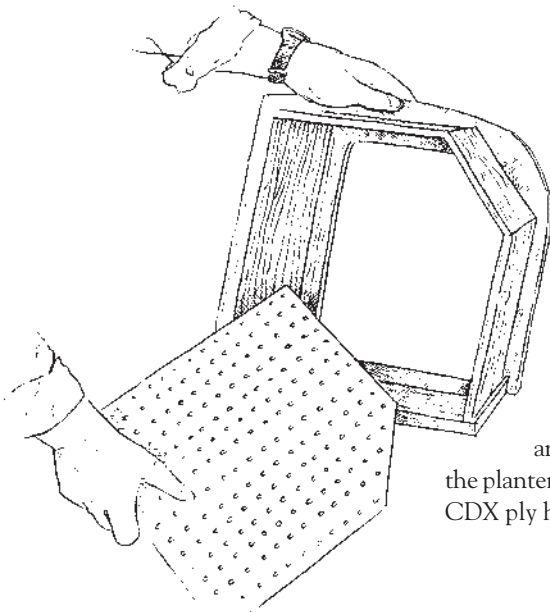
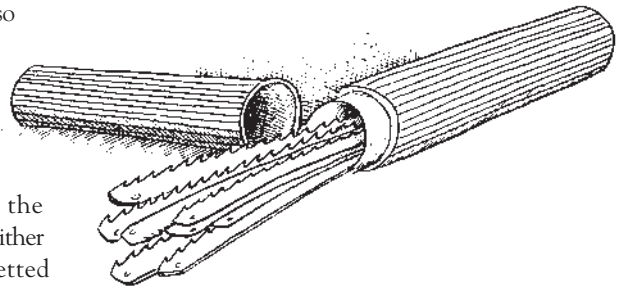

Plastic Pegboard Won't Rot

While building an outdoor planter recently, we ran across the age-old problem of finding outdoor materials that hold up to water and sun, but still look good. Even more daunting was constructing a bottom that would hold up to moisture and still allow water to drain out of the planter. Drilling holes in water-resistant CDX ply had been the plan, but when we

got to the home center store we found a 2' x 4' sheet of 1/4"-thick stout plastic pegboard that was priced at \$6. Perfect! Not only will it hold up to all sorts of abuse, but it's already got the drainage holes drilled. And you can use the holes on the edges of the pegboard to fasten it to your planter. The pegboard cuts easily with a jigsaw to fit any planter project you have in mind.

The Popular Woodworking editors

Lock In Ammonia Fumes with Tinkertoy Technology

I recently refinished an antique Morris chair for a client. To my delight, the owner gave me the leeway to color at my discretion. I was interested in trying out fuming on a large scale and set about to construct a fuming chamber. After a couple moments of contemplation, I hit on an idea that I thought was worth sharing. I started by boring three 1"-diameter holes in eight small blocks of wood, two on adjacent sides, the other on the side above them. Then I took 1" dowels and inserted them into the holes in order to construct the cube. After the cube was erected, I wrapped the whole thing with commercial-grade plastic wrap. Then I cut a hole in the wrap, inserted the chair and my ammonia, and re-wrapped the hole

with plastic wrap. The cellophane is inexpensive, practically airtight and allows you to view the oxidation as it proceeds. When finished, I tore the cellophane, extracted my piece and disassembled the chamber.

Yoko O. Sorensen
Raleigh, North Carolina

Editor's note: This temporary chamber also would work well for keeping dust and bugs off wet finishes. Instead of cellophane, you also could use plastic painters' drop cloths and tape the seams shut over the frame. **PW**

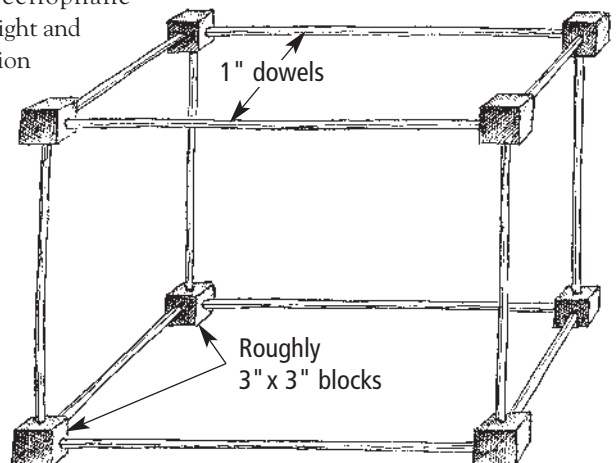

Wrap entire structure in cellophane.

FREE TOOL CATALOG!

Your Best Work Starts With Us...

With over 8,000 of the finest woodworking tools in the world, Woodcraft can help you work more efficiently and skillfully than ever. Call for your Free copy today.

1-800-542-9115



WOODCRAFT
Helping You Make Wood Work®

www.woodcraft.com

Visit one of our stores located nationwide! Call us for the store nearest you.



Proud sponsor of "The American Woodshop" hosted by Scott Phillips on PBS.

560 Airport Ind. Park,
Dept. 02PW06Q,
PO Box 1686,
Parkersburg, WV
26102-1686

CIRCLE NO. 123 ON FREE INFORMATION CARD.

JOINTECH
Ultra-Precision Woodworking Systems
11725 Warfield - San Antonio, TX - 78216

The Upscale Alternative
Protected by 5 Patents

CabinetMaker's System®



The Best System For:

- Cabinet Making
- Routing
- Joint Making
- Joining

SMART MITER™



AUTO-ZERO - FULL 100° SWING

- Scale Reads Inside & Outside of any Miter Cut
- Ultra-Precision, Incremental Crosscut & Miter Sled
- Zero Blade Clearance At All Angles
- Full Measure, 48" Incremental Fence
- Jointech Leadscrew Technology



Jointech Saw Train
For Cabinet Saws - Bench Saws - And The Shopsmith® Machine

With our **NEW Saw Train** you can now bring incredible precision to any Cabinet, Bench or Contractors saw... With Jointech all you need is **ONE FENCE** to do it all - NOT THREE!



- 5-PT Locking System
- Absolute Parallelism
- Large Rip Capacity
- Vacuum Fence
- Micro-Adjustable
- Incremental Accuracy

FOR A CATALOG CALL:
1-800-619-1288

Jointech, Inc. and Shopsmith, Inc. are not affiliated.
Shopsmith is a Registered Trademark of Shopsmith, Inc.
Jointech, CabinetMaker's System and Smartence are Registered Trademarks of Jointech, Inc.



The Ultimate Upgrade

www.jointech.com

CIRCLE NO. 111 ON FREE INFORMATION CARD.

When It Comes To DH Kilns,
There's Only One Original.

Whether you're drying 300 board feet or three million, you'll get the performance and results you need with the world leader in dehumidification lumber drying: Nyle Dry Kiln Systems.

Nyle kilns cost less to install and operate than conventional kilns, and our patented technology gives you exact control of kiln conditions for superior drying quality. With a Nyle system, DH drying is an economical, high-quality option for even the largest drying operation.

For FREE facts on a system for your business, go to:

www.nyle.com

nyle
DRY KILN SYSTEMS

(207) 989-4335
FAX (207) 989-1101
1-800-777-6953



P.O. Box 1107 Bangor, Maine 04402-1107

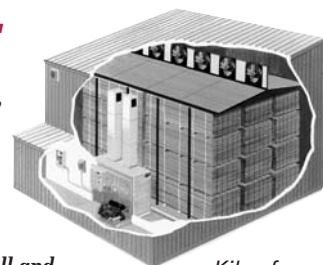

Kilns from
300 to 350,000 BF

Nyle DH Kilns

- Use 50% to 60% less energy than conventional kilns
- Provide outstanding drying performance
- Give you unbeatable quality and reliability

CIRCLE NO. 118 ON FREE INFORMATION CARD.

CIRCLE NO. 116 ON FREE INFORMATION CARD.

The Dream Shop

A visit to Scott Phillips' brand new 'American Woodshop' shows that any size shop faces the same challenges and rewards.



Photos by Al Parrish.

When I first designed and outfitted "The American Woodshop" in 1970, I thought I'd have everything set up perfectly within a year. It's now 32 years later, and I think I might be close to getting my "dream shop" the way I want it.

Most shops are clever adaptations of existing space. They're usually packed with wood and tools, and there's never enough

room for everything – especially wood. Five years ago, I started looking for a new woodshop, in part to make producing my public television series easier to shoot. Many people would say that it's easier to buy or fix up an existing space. I can't argue with that logic because they would be right. But I decided that to get everything the way I wanted it, I'd have to start from scratch.

Zoning issues ruled out most locations. I finally found two acres that were zoned for business but were in a rural setting. It's in the city limits (we shoot my show in Piqua, Ohio) so I still get all the city services.

The first step was to sketch out what I thought I needed (my dream shop looked great on a napkin), then to double the size. Expect to spend about \$30 to \$40 per square foot if your shop is built on a concrete slab with a traditional footer. Next I enlisted the help of the Upper Valley Joint Vocational School in developing a design for the building. The students and teachers added a lot to the shop project, providing invaluable plan designs and drawings.

The construction is stick-built with a concrete pad footprint of 32' x 92'. The roof is metal with a 9/12 pitch and 10'-high ceilings inside. If you're doing math in your head, that gives me a 2,944 square-foot shop, but it all isn't available for building projects.

I partitioned the 12' x 32' built-on porch for those necessary moments to stop and ponder my plans, and the front part of the building includes an office, project gallery, restroom and utility room. That brings the main woodshop room down to 64' x 32' – only 2,048 square feet. But it's still a luxury with plenty of room for everything I do.

My machines are set up for both 110- and 220-volt power. To keep everything running, I selected a 110/208 three-phase SquareD



This shot gives you a feel for the full length of the shop, with everything fairly organized. There's lots of room now; the trick is to keep from filling the place up with more tools. You can see the large garage door in the back that makes moving lumber, equipment and projects in and out much easier, as well as letting that warm summer air in. I know you're wondering about the rug. Well, it's actually a temporary sound dampener for when we shoot the TV program. It seems sound bounces off the door pretty badly.

200-amp breaker panel. This gives me voltage flexibility and also saves me money when I run three-phase tools and utilities.

The shop thermostat, which is zoned so the electric three-phase heat pump can be used efficiently, keeps things comfortable. The heat pump works both as a furnace and an air conditioner with central duct work in the attic and all registers in the ceiling. The main shop return air duct is equipped with an electrostatic prefilter that acts just like the world's biggest ambient air cleaner. And because I have learned that 80 percent of all heat and air conditioned energy is lost through the ceiling, I opted to blow r38 virgin fiberglass into the attic.

Lighting is one of the most important aspects in any shop, and you just can't beat working with natural light. I installed lots of 48" x 62" double-hung windows. These let in daylight, make things easy on the eyes and save on the lighting bill. For when the sun isn't shining, I installed dual 8' florescent low-noise/high-output daylight florescent tubes. The tubes produce an 87 c.r.i. (color rated index), are a good buy and come very close to the daylight spectrum. This translates into less eye fatigue and better work.

Where dust collection is concerned, most people make setting up a system too complicated. I opted to use three 1,100 cfm (cubic



feet per minute) dust collectors and kept all hose and pipe runs short and sweet. A remote on/off switch for a dust collector is a real time saver. An ambient air cleaner by the workbench where I sand the most picks up dust that the other systems don't catch.

My shop basically is divided up into complementary tool zones. This is called the workstation concept, where tools are arranged to work most effectively together. For instance, a compound miter saw, table saw, jointer and planer are perfect companions. When these four tools are positioned together, 90 percent

of furniture project preparation can be completed in this one zone. Plus, this makes it easy to hook up all the tools to a dust collector and saves time when moving from tool to tool during construction.

It also makes sense to put all the hand tools in cabinets by the best light so you can use your workbench most efficiently. Any time a woodworker has to walk across the shop to fetch a tool, you can bet the setup can be improved. Maybe this is why it's taken me 32 years to get my new shop just about right.

I still believe in the versatility of casters and mobile bases because this allows me to easily reposition tools for large work pieces and store them when they're not needed.

One huge luxury in the new shop is the 18' x 9' insulated garage door at the back of the shop. On good-weather days, the door goes up and the joy of working in great light and air is exhilarating. Often, I roll the planer or sanders outside and let the chips fall where they may. Plus, when it comes time to use my high-volume, low-pressure spray finishing system, you can't beat the ventilation. When the weather's not good enough to open the door and spray, environmentally friendly finishes such as water-based polyurethane, shellac, wiping gels and true oil finishes are easy and safe to use.

A few extras (I didn't tell my wife, Suzy, about these things) are the in-floor concrete electrical plates that cost about \$300 each installed, extra incandescent track lighting to add highlights, three monster fire extinguishers (required) and a security system that



The single most important tool in my shop is the 352-pound European-style Ulmia workbench. This heavy-duty bench can't be pushed around and is like an aircraft carrier with lots of room to do whatever I want. It also has a tilting drawer which (confession is good for the soul) is one great catch-all with a lock. The drawers never stay neatly arranged if much work is getting done in the shop. I prefer to keep the bench pulled away from the wall so I can work on all sides of it as necessary.



I almost forgot one of the most important parts of my new shop: Callie. Every woodshop needs a shop dog. She keeps me company, chases dropped tools and generally keeps things lively. This is just one of Callie's favorite places to hang. The well-lit corner provides a great place for fine work on the scroll saw. One addition to my machinery that I highly recommend is the foot pedal by the band saw to turn the dust collector on and off. It saves a few steps and makes it easier to remember to keep the dust out of the air.

protects a lifetime of accumulated tools and also will call the fire department in case it detects smoke.

I did run into some snags. First, I'm 25 percent over my budget. I expected that, and so should you if you build a new shop. I had to install a retention pond to control the roof and parking lot runoff (\$8,000); the shop lane and 20-car parking lot had to be paved to comply to code (\$10,000); architect's fee (\$2,000, even if you do most of your own preliminary design work and have the help of J.V.S. students); engineer's site plan and required building permits (\$1,250); and extra gravel for the access lane and raising the elevation grade for the slab floor (\$4,000). And then there's the miscellaneous extras from emergency exit signs, locking gate, plumbing extras and landscaping (another \$3,000).

There were some good things about the process, too. Over the years I've accumulated thousands of board feet of Midwestern hardwoods, and I've always dreamed about having a barn for lumber drying and storage.

My new property came with a beauty of a barn! The post-and-beam work in the barn dates back to 1840, according to a local historian. All posts are hand hewn. Though the barn is in relatively good shape, it does need some fixing up. I figure about one year's work. But guess what? I have to make the barn comply with local covenants. That means another \$20,000 in roofing and siding! **PW**

—Scott Phillips, contributing editor



AMERICAN WOODSHOPS

Woodworkers love to see the shops of other woodworkers. And few people see as many notable shops as Scott Phillips, host of

PBS' "The American Woodshop." Every issue, Phillips takes us inside the shops of some of the finest craftsmen (and women) in America. You can see more about Phillips' new shop by tuning in to "The American Woodshop" on your local PBS station or visit Woodcraft Supply (www.woodcraft.com) to purchase a videotape of the show.

Build Your Own Corporate Ladder.

We can supply the right tools.



Become a Woodcraft Franchise Owner.

Owning your own business can be empowering, especially when power tools are involved. Turn your love for woodworking into a dynamic investment by becoming a Woodcraft retail store franchise owner. Contact us soon. Opportunities are limited.

To find out more contact:
Bill Carroll
Director of Franchise Operations
bill_carroll@woodcraft.com
304-422-5412
F02PW06Q



WOODCRAFT®
Helping You Make Wood Work®

1177 Rosemar Road, P.O. Box 245
Parkersburg, WV 26102-0245

Looking for quality woodworking information on the Web?

Log on to

www.popularwoodworking.com

It's your fast and easy connection to 100s of woodworking Web sites. You'll find accurate, updated links to tool manufacturers, project plans, catalogs, discussion groups and much more. Check out this **FREE** service. Log on today!

New from...

Lie-Nielsen TOOLWORKS INC.

Rabbit Block Plane
\$150 + shipping

www.lie-nielsen.com
P. O. Box 9, Warren Maine 04864

Free Catalog 1-800-327-2520

Build Furniture That Lasts!

THE Biscuit Joiner PROJECT BOOK

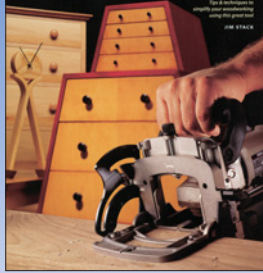

Creating strong, durable joints has never been easier with the biscuit joiner. And now you can use this practical technique to creating wonderful new pieces of furniture for your home!

With 12 projects, including a bookcase, nightstand, chest of drawers, and entertainment center, you'll discover the value of the biscuit joiner for stylish, durable, and functional furniture. Best of all, you'll be amazed at how quickly you can turn your home into an artful display of your crafts!

Order your copy of *The Biscuit Joiner Project Book* today!
#70531-K/\$26.99/128 pgs/pb/200 color illustrations

Available at your favorite bookseller or directly from the publisher using the Order Form below.

ORDER FORM

YES! Please send me _____ copy(ies) of *The Biscuit Joiner Project Book* (#70531-K) \$26.99 each

SUBTOTAL: \$ _____

In the U.S. please add \$3.95 shipping and handling for the first book, \$1.95 for each additional book. In OH, NY, CO and MI, please add applicable state tax. In Canada, add US\$5.00 shipping and handling for the first book, US\$3.00 for each additional book, and 7% GST. Payment in U.S. funds must accompany order.

TOTAL: \$ _____

Check or money order enclosed -or-
 Charge my VISA MC AmEx
Acct.# _____

Expiration date _____

Signature _____

Name _____

Address _____

City _____

State/Prov. _____ ZIP/PC _____

Send to:  Popular Woodworking Books
PO Box 9274
Central Islip, NY 11722-9274

ZAE02B1

For more information or to order by Credit Card visit www.popularwoodworking.com/store/books or call toll free 1-800-221-5831

Save Money—saw your own lumber.



LT15G13 Personal Sawmill

Make Money—saw for others.

- Cut logs up to 28" D. x 11' L.
- Extra bed sections permit longer lengths.
- Easily transportable.
- Video available.

Free \$2! Catalog!

Prices & specifications subject to change w/o notice.

Wood-Mizer®

Number One in Worldwide Sawmill Sales

www.woodmizer.com

8180 W. 10th St. Dept. DF56
Indianapolis, IN 46214

Call for the location nearest you!

1-800-553-0219

\$4995

STOP!

Before you buy your next tool, see how it performed in *Popular Woodworking's* workshop!

Just log on to popularwoodworking.com. There you'll find out how dozens of tools performed in the *Popular Woodworking* shop. Plus, each review lists key features and important facts you need to know to make a smart and savvy tool purchase. Check out this **FREE** service!

Log on today!

www.popularwoodworking.com

HIGH PERFORMANCE MOBILIZATION



What's under your machine?

HTC Mobile Bases give you convenient shop clean-up, make moving, using and storage a breeze — and open-up valuable shop space for more equipment. Making it mobile just makes sense! *What are you waiting for?*



For your nearest dealer and FREE catalog, call toll-free 1-800-624-2027



CIRCLE NO. 110 ON FREE INFORMATION CARD.

© HTC Products, Inc. 2001

Bosch 5" Random-orbit Sander with Superior Dust Collection

We're not always enthused about getting a new sander to test. Let's face it, few people enjoy sanding. So the best thing we can hope for when testing a sander is that it will work more quickly, create less dust and work without a lot of vibration.

Bosch has two new 5" random-orbit sanders that try to fill this bill: the 1295D, a single-speed tool, and the 1295DVS, a variable-speed model. We tested the variable-speed model. The 1295DVS boasts a 2.2-amp motor with variable speeds ranging from 7,000 to 12,000 rpm so you can adjust the aggressiveness of the stock removal. The eccentric offset (also called the orbit size) on the sander is stated at $\frac{1}{16}$ ", making it one of the smaller offsets in the category, but the sander's performance tends to belie that statistic. We had good results: quick removal and low sanding-swirl problems. The sander's pad-dampening system provided good protection against swirls when the running sander met the wood.

Most impressive during our testing was the performance of the new Microfilter dust canister filter system. Bosch has drawn on some of its automotive experience and incorporated a pleated filter that is rated to trap particles as small as .25 microns. The thickness of a human hair usually is in the 100-micron range, with common pollen checking in as small as 10 microns, so this is a pretty good filter.

This all sounds good in theory, but what about in the shop? We found the 1295DVS a pleasure to sand with. Little dust escaped the through-the-pad collection system. You'll

need to clean the filter out every so often, but all-in-all, this is some of the best dust collection we've seen outside of using a vacuum hook-up, which also is an option with this random-orbit sander.

The feel of the sander also was good, with a soft-grip top adding some comfort while allowing a solid grip on the tool. We did notice vibration and somewhat overactive pulling from the sander when we weren't using the full pad against the material. While this is something to be aware of, we didn't find it a problem with the tool's performance.

Another nice feature is the sealed switch that keeps the internal electronics free of dust, which leads to longer life.

We were a little concerned initially that the somewhat large and rigid plastic dust col-

lection box would get in the way during use, but once we started sanding we didn't notice it anymore.

Overall we found the 1295DVS to be a good all-around random-orbit sander with superior dust collection, and rapid and aggressive material removal. The price for either the variable- or single-speed model is in line with all the other manufacturers' models, making this a strong competitor.

For more information, circle #142 on Free Information Card.



SPECIFICATIONS

Bosch 1295DVS Sander

Street price: \$90

Amps: 2.2

RPM: 7,000 - 12,000

Disc: 5"

Orbit diameter: $\frac{1}{16}$ "

Weight: 3.5 pounds

Filter efficiency: .25 microns

Performance: ●●●●●

Value: ●●●●○

Bosch Tools: 877-267-2499 or

www.boschtools.com

HOW WE RATE TOOLS

At *Popular Woodworking* we test new tools and products with an honest, real-world workout. We check for ease of assembly and determine how clear and complete the manuals are. Then we use the tool in our shop to build projects that appear in the magazine. Each issue, our editorial staff shares its results and experiences with the tools.

We use a one-to-five scale, with "five" in performance indicating that we consider it to be the leader in its category. For value, "five" means the tool is a great deal for the money, while "one" means we consider it pricey. Though, a unique low-value tool may be worth the price.

If our tool reviews don't answer all your questions, e-mail me at david.thiel@fwpubs.com or call me at 513-531-2690, ext. 255. You also can visit our website www.popularwoodworking.com to check out previous tool reviews and sign up for our free e-mail newsletter (focusing on tools) that's sent out every other week.

—David Thiel, senior editor

Freud's SH-5 Router Table Fence System

Freud Inc., known for more than half a century as a leading manufacturer of carbide bits and blades, now is offering another accessory to put those router bits to good use. With the addition of the SH-5 router table fence, Freud now offers everything you need to get routing, including the router.

The SH-5 is a split-fence system with micro-adjustable faces that work like the fence systems on high-end shapers. Made of cast and machined aluminum and steel parts, the Freud fence system offers infinitely and independently adjustable in-feed and outfeed fences, with graduated marks on the micro-adjuster calibrated to .001".

The fence faces are 5/8" melamine-clad medium density fiberboard, with a bearing length of 25" across both fences and a height of 2 3/16".

The fence is designed for use on the Freud router table, but it can be used on any homemade table by installing threaded inserts in your tabletop.

In testing, we found the micro-adjustability of the fences to be a strong selling point. The precision and adjustability allowed for any offset required for use as a jointer, for offset profile work or for easy and perfectly flat alignment along the faces. Locking knobs hold the fences in place effectively, once they are positioned for your cut.

The housing is constructed of a simple but sturdy steel casting that should last for many years of use.

While the fence faces included are designed to be replaceable if damaged and are certainly adequate to the task, we'd likely replace them with taller plastic (phenolic resin) fences for increased support and durability.

We continue to wonder how much woodworkers will spend for a fixture, rather than make their own. But considering the micro-adjustable split-fence feature (not available on many other aftermarket fences for router tables) and the durability of the Freud unit, we'd spend the money on this nice fence and build our own router table.

For more information, circle #143 on Free Information Card.

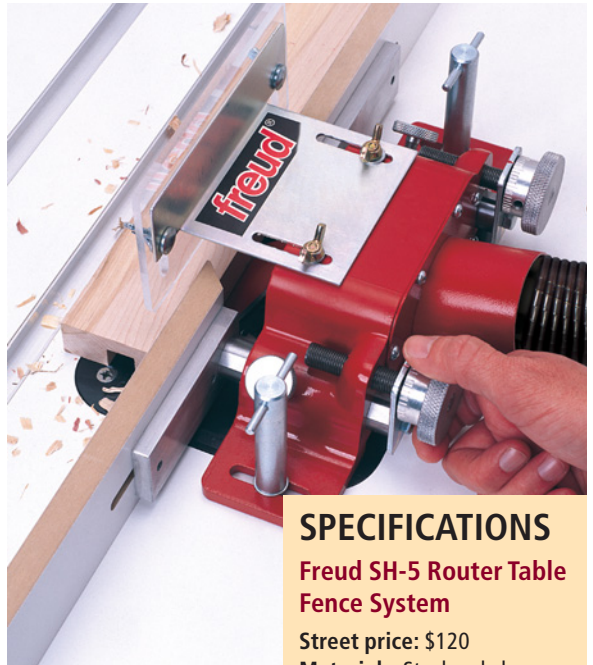

SPECIFICATIONS

Freud SH-5 Router Table Fence System

Street price: \$120

Materials: Steel and aluminum

Fence accuracy: .001"

Fence size: 2 3/16" x 25"

Performance: ●●●●○

Value: ●●●○○

Freud: 800-334-4107

or www.freudinc.com

Bench Dog ProLift Offers Convenience and Stability

It used to be you just cut a hole in a top and screwed your router to the underside and voila! You'd made a router table! Nowadays it's a science in its own right – with a price tag that would make the Department of Defense smile. Well, truth be told, the new router table inserts are pretty slick, and there are real benefits to them.

Two new models from Bench Dog are essentially similar, with the ProLift Ni's motor housing and base plate constructed of cast iron, while the same pieces on the ProLift Al are made of aluminum. The Ni version is designed for use with large fixed-base routers such as the Porter Cable 7518. It also prices at about \$380. The Al is designed for use with the 1 1/2 horsepower fixed-base routers, but still includes the same steel columns and bronze bushings. Priced at \$260 (which still isn't chump change) it's more approachable for the home woodworker, so we'll focus on the aluminum model.

The ProLift allows convenient from-the-top adjustment of router height using a 9/16" socket driver. In fact, with the reduction ring removed,

the router can be run up above tabletop height for easy bit changing. The router is clamped tightly in place in the motor housing and raises and lowers on two 8 teeth-per-inch acme-threaded rods for smooth and balanced adjustment. Two reduction rings adjust the opening size from 2" to 3 3/4".

The ProLift operates smoothly, provides stable, sturdy support and fairly easy access for bit changing. We weren't in love with having to remove three hex-head screws to remove the reduction rings (a snap-in or twist-lock design would have been better), but we like the performance and convenience offered by this lift. Bench Dog has provided a rock-solid and convenient lift; you need to make the decision regarding its value in your shop. **PW**

For more information, circle #144 on Free Information Card.

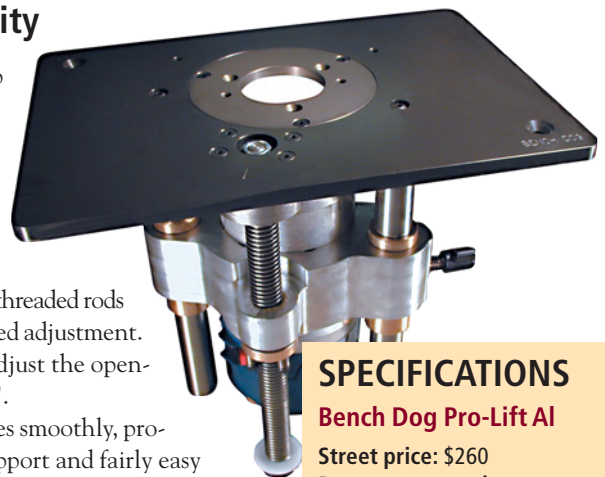

SPECIFICATIONS

Bench Dog Pro-Lift Al

Street price: \$260

Routers accepted:

Porter-Cable 690

Bosch 1617/1618

DeWalt 610

Makita RF1100/01

Bit openings: 2", 2 5/8", 3 3/4"

Performance: ●●●●●

Value: ●●○○○

Bench Dog: 800-786-8902

or www.benchdog.com

Band-sawn Pencil Posts

Don't have a jointer or a router? Here's another way to build eight-sided tapering posts.

One of the axioms of woodworking is that there are always at least three good ways to accomplish any one task. This, in fact, was the premise of a book by a good friend of mine, Bob Moran, author of "The Right Technique" (Reader's Digest). Bob proves this old saw by showing the reader three ways to accomplish dozens of common woodworking chores. The healthy sales of his book also prove that woodworkers tend to collect these techniques the way cooks collect recipes.

When the folks at *Popular Woodworking* told me they were planning a project on a pencil-post bed, I said, "I've got a nifty jig for making pencil posts." And, sure enough, my technique was different from the one that Troy Sexton used to make his bed. Not better, just different. So for those technique collectors among you, here's another pencil-post recipe for your files.



The holder cradles the pencil-post stock and indexes it every 45°, allowing you to cut a perfect octagonal taper on your post.

Begin by tapering the faces of the stock. As you cut, make sure the bottom of the post is butted against the end of the jig. Wedges hold the post in position at the top of the jig.



Pencil-post Jig

My particular technique relies on a tapering jig – a very long tapering jig designed to be used on the band saw. This jig holds the pencil-post stock at a slight angle to the blade – 0.83° in the example shown. The top of the post is held by a dowel so the post stock can pivot. The bottom portion of the stock is cradled in special holders. These holders index the stock so you can turn it precisely 45° between cuts.

As shown in these drawings, the jig will help to create a pencil post that's 82" long and 2½" square. However, the design can be adapted easily to make posts of any size. First, rip the side and base of the jig from the long edges of a sheet of ¾"-thick plywood – the factory edges will be relatively straight. Stack the holder parts face to face and cut two identical holders. Drill the hole in one end and assemble the parts, except for the dowel pivot and the middle holder.

You want to leave the dowel loose so you can mount the stock in the jig and take it out again. To position the middle holder, mount a post in the jig and place the holder under it. Slide the holder along the post until it's 30" from the bottom end. Mark the position of the holder on the base, then attach it with screws. Don't worry that one end of the middle holder hangs over the edge of the base. You'll cut this off when you make your first pass on the band saw.

Making a Band-sawn Pencil Post

To mount the post stock in the jig, you must drill a ½"-diameter hole in the top end. (After making the post, you can use this same hole to attach the finial if you have one.) Mount the post stock in the jig and turn it so one of the faces is parallel to the band saw blade. Mount a fence on the band saw and position it so the distance from the fence to the blade is equal to the width of the jig.

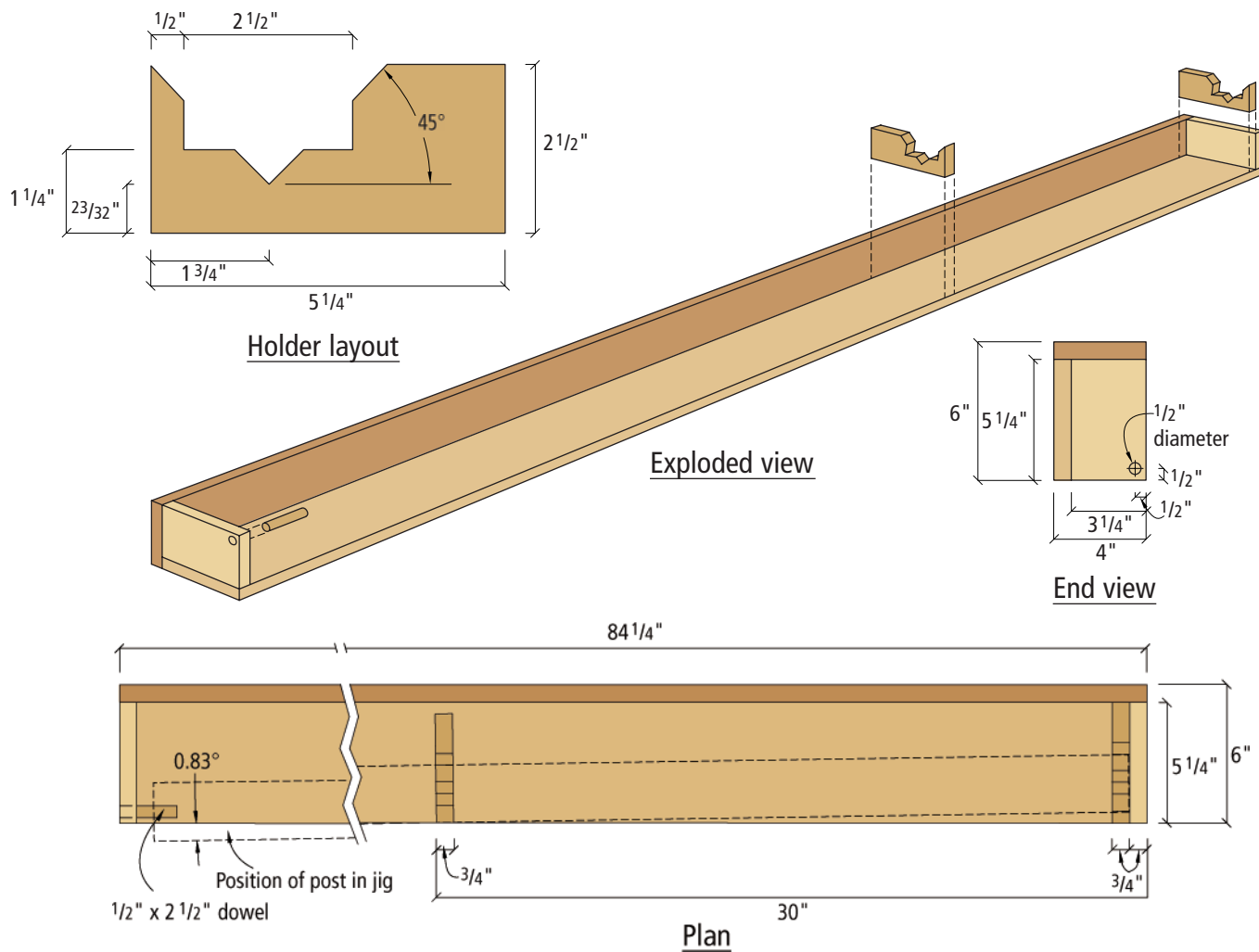

Slowly feed the jig and the stock past the blade, keeping the back of the jig firmly against the band saw's fence. Cut tapers in the faces of the stock, turning the stock 90° between each cut. The blade should exit the stock at the middle holder, 30" from the bottom end of the stock. When you've finished this step, you should have a four-sided taper.

If you were to continue cutting the corner tapers in this manner, they would exit near the bottom of the post. This is because the post is wider when measured diagonally than it is when measured across the face. To stop the corner tapers at the same point as the face tapers, you will need to cut transition curves in the corners.

To figure the radius of these curves (R), subtract the width of the stock (W) from the diagonal measurement (D). Then subtract



After cutting the face tapers, mark the transition curves on the corners of the post. I made a simple marking jig to do this quickly and accurately.



Cut the transition curves with a coping saw. Take it slow and monitor the lines on both sides of the cut. Cut on the "waste" side of the line. Later, you can sand or file the curves to the line to shape them precisely.

INGENIOUS JIGS

the result from the width and divide by two. The equation looks like this:

$$[W - (D - W)]/2 = R.$$

For example, if you're making a pencil post $2\frac{1}{2}$ " wide, the diagonal measurement is $3\frac{17}{32}$ ". Plug these values into the equation, and you'll find the radius of the transition curve should be $\frac{47}{64}$ ". Mark the radius on both sides of each corner, then cut the curves with a coping saw.

Rotate the stock in the jig so the faces are 45° to the blade. Cut the corner tapers, stopping when you reach the transition curves. Between each cut, back the jig out of the saw and rotate the stock 90° .

After cutting the tapers, smooth the sawed surface with a block plane, scraper and sandpaper. Don't cut too deeply when you plane or scrape! You just want to remove the saw marks; you don't want to change the symmetrical shape of the post.

Tip: To get the smoothest surface possible when cutting with your band saw, use a blade with milled teeth. Ordinary band saw blades are stamped and set, but most woodworking suppliers carry a better brand of milled blade. They cost about twice as much as an ordinary blade, but they save an enormous amount of work when you need an accurate cut and a smooth surface. **PW**

Nick Engler is the author of more than 50 books on woodworking, plus countless articles. Currently, he's helping kids across America build ribs for a full-size replica of the first true airplane, the 1903 Wright Flyer.



Cut the corner tapers up to the transition curves. Be careful not to cut past the curves; stop the moment the waste falls away and back the stock out of the saw.



Plane and scrape the saw surfaces just enough to remove the saw marks. The pencil-post jig holds the post for this operation; just clamp the base to your bench.

CENTENNIAL FLYER UPDATE

In our quest to build a Wright 1903 flyer using ribs made by children, we're about halfway to our goal of 74 ribs – the total number of wing ribs in the frame of the airplane. And we've begun to make the other parts needed for this airplane: struts, spars, skids and so on. Dayton's oldest bookstore, Wilkies, decided it would be a great thing if we made these parts and put the Flyer together right out in the open. So Wilkies gave us the front portion of its store, an area about the size as the Wright brothers' workshop where they built bicycles and airplanes.

Shopsmith Inc. – another community-minded business here in Dayton, Ohio – also helped out by equipping our shop. We're busily making the parts and putting together the Flyer with a Shopsmith Mark 510 and a dozen other Shopsmith power tools and accessories. Wilbur and Orville never had it so good.

If you'd like to watch us work, the "Centennial Flyer Workshop" is located at Wilkies on Fourth and Ludlow streets in downtown Dayton. Every Saturday is kids' day. We have rib-building workshops and other

activities in the shop or the bookstore. Check out www.wrightbrothers.org and follow the links to the Centennial Flyer pages.

Our final "Return to Kitty Hawk" is fast approaching. We'll be flying the 1900, 1901 and 1902 Wright gliders at Jockey Ridge State Park in North Carolina on Oct. 5–8, 2002. As always, you're welcome to come.



Kids sign the ribs they made at a recent rib-building workshop.

Jet's Planer/Moulder

This machine is a substantial upgrade from a portable planer with extremely versatile moulding-making capabilities built right in.

If there's a flaw in Jet Tools' combination thickness planer and moulder, it's that just about the time you want to plane some stock you realize the cutterhead has moulding profile knives installed. Of course, this really isn't a flaw at all, but it does make me envious of those disposable knives in portable planers that rest on indexing pins that you can change in the dark. But I look on the sunny side and realize my knife-setting skills have advanced markedly since I bought this handy machine nearly five years ago.

Since that time I have probably run as many lineal feet of moulding as I have lumber through the 13"-wide planer, and it has performed admirably at both tasks. Much of the moulding has been a relatively wide 3/8" picture frame profile that requires a pretty heavy cut. I've cut this profile in maple, ash and poplar, and the 1 1/2-horsepower motor hasn't bogged down yet. Plus, with a two-speed gear box, this means that just a light sanding is necessary when a final pass is made in the 10-feet-per-minute mode. (The faster speed is 20 feet per minute.) Changing speeds is a bit of a mess, however. You have to remove a piece of the side cover and swap the position of a couple grease-covered gears.

In spite of the inevitable greasy fingers, the variable speed is one of my favorite features of the machine. Though the slow speed is intended for moulding operations, I switch over to the slow speed when working with highly figured woods, and it really makes a difference. Curly maple and oak are much less likely to tear out at the slower speed. And if you wet the board a minute or so before planing it, you can eliminate even more tear-out in these woods.

I also have a predilection for wide lumber, and running 13"-wide boards through the planer hasn't presented any problems, either. This is in spite of the fact that the machine does not have lower bed rollers. The

guts of the machine come from a 1 1/2 hp motor that sits beneath the machine. It comes wired for 110-volt operation, but easily can be switched to 220-volt operation. The twin pulleys and belts efficiently transfer power from the motor to the cutterhead. The belts are tensioned by the position of the motor. It's a good idea to check the tension of these belts every year or so. Taking up any slack is a simple task and improves the planer's performance.

The large 2 3/8"-diameter cutterhead is a full inch larger than ones typically used in portable planers. The three-knife cutterhead also has knife-jacking screws that aid in knife-setting. When used as a moulder, the moulding profile knives are set in the cutterhead as the planing knives are. Most moulding knives less than 2" in width can be installed in the cutterhead without removing the planing knives – a nice feature.

In addition to installing cutterhead knives for moulding and removing the chip deflector, it also is necessary to adjust the height of the top-mounted, rubber-coated infeed and outfeed rollers. The pressure of the feed rollers is adjusted on the top of the machine by loosening a jam nut and turning a threaded bushing. Start with the settings recommended by the Jet manual, but don't be afraid to adjust them up and down a bit if your work seems to struggle under the cutterhead, especially in the planing mode. These minor chores require only a few minutes time.

The cutterhead is just one example of what makes this a solidly built machine. The bottom, bed and top of the machine are substantial castings. With an open stand the JPM-13 weighs in at more than 200 pounds. The enclosed base option (the JPM-13CS) takes the weight up to 242 pounds. Both models come with locking casters.

Aside from the motor and the cast-iron



SPECIFICATIONS

JET JPM-13

Street price: \$850 (closed-stand version available for \$900)

Motor: 1 1/2 horsepower induction motor
RPM: 4,500

Max planing width: 13"

Max planing thickness: 6 1/8"

Max cut (full width): 1/16"

Number of knives: 3

Weight: 202 pounds

Nice features: A heavy-duty planer that also cuts mouldings.

Recommended modifications: We wish the feed speed and the knives were easier to change.

Available at: Jet dealers nationwide. Contact Jet at 800-274-6848 or www.jet-tools.com

ABOUT OUR ENDURANCE TESTS Every tool featured in our Endurance Test column has survived at least two years of heavy use in our shop here at *Popular Woodworking*.

construction, the other major differences between the Jet and portable machines include the ability to easily adjust things such as the chip deflectors, the position of the feed rollers and the feed speed of the planer. These make the Jet more flexible for a wide variety of planing situations. **PW**

— Steve Shanesy

Building the Perfect Bed

Your bed needs to be one of the toughest pieces of furniture you own. Learn the best way to install traditional bed hardware and then build this stunning pencil-post bed.

Building a bed is a great project for beginning woodworkers. There aren't a lot of parts, the joinery is simple and the results can be impressive.

We spend one-third of our lives sleeping in bed, but this piece of furniture also is a place to read, watch TV and play with the kids during waking hours. For those reasons, a bed needs to be extra sturdy. You also need to be able to knock it down easily into parts to get it through the door.

The ultimate piece of hardware that satisfies both these needs is the lowly bed bolt. When installed properly, a bed bolt creates the strongest woodworking joint I can imagine. And with a wrench, you can disassemble a bed in minutes.

Sure there are other kinds of bed hardware that attach the rails to the posts, but if you know the tricks to installing bed bolts, you'll never use anything else again.

I've built a lot of beds for clients throughout the years. And one of my most popular designs is this pencil-post bed. In Colonial times, pencil-post beds were draped with curtains at night to conserve heat and increase privacy.

The high posts were never meant to be seen. Over the years the simple straight posts gave way to octagons and more ornate and carved forms.

A lot of plans for pencil posts show the woodworker shaping the octagonal taper with a drawknife. With my method, you can cut a perfect taper in 10 minutes for each post. (*Editor's note: For another method, check out Nick Engler's Ingenious Jigs column on page 28.*)

Even if you don't want to build this particular bed, all of the construction principles apply to whatever type of bed you want to make. Plus, I've included some of the rules to follow when building beds. There aren't many, but they're important.

Begin With the Posts

This particular bed was made using cherry, but I've made a lot of these in maple, too. Cut your posts from 10/4 rough lumber and cut them about 1" longer than stated in the cut

by Troy Sexton

Troy Sexton designs and builds custom furniture in Sunbury, Ohio, for his company, Sexton Classic American Furniture. Troy is a contributing editor for Popular Woodworking.



Try to do as much work on the posts – mortising, drilling, etc. – before you cut the octagonal tapers.

Photo by Al Parrish.





Mark the taper on two sides of each post (below), band saw proud of the line (right) and then joint each face. Mark the taper on the other two faces and repeat.



It takes a steady hand on your router, but it's pretty easy to chamfer the edges of the tapered sides into an octagon (left). Here's a closeup of the end of the post when you've chamfered all four edges (above). It looks a little banged up, but once you cut off that extra 1" it will look perfect.

STANDARD MATTRESS SIZES

You want your mattress to fit close against the rails. As a rule of thumb, make your rails (between tenons) the same length as your box spring's width and length. With this particular bed design, you'll get the right gap.

	Width	Length
Twin	39	75
Double or full	54	75-80
Queen	60	80-84
King	76	80-84
California King	72	84

STANDARD BED HEIGHTS

When determining where to put your rails on the posts, aim to end up with your mattress at one of these heights:

- 18" -high Bed: A common height for a platform bed. When you sit on this bed, your knees will be bent.
- 25" -high Bed: The most common bed height. When sitting on the bed, your legs will be mostly extended, but your feet will reach the floor.
- 36" -high Bed: Common on antique beds. When sitting on the bed, your legs will not reach the floor.

list. Joint and plane the posts down to 2 1/4" square.

With the posts square, now is the best time to lay out and cut all the mortises for the rails, the footboard and headboard. All of the mortises are 3/4" wide and 3/4" deep and centered on the posts. My mortiser can handle a 3/4" bit, so I cut the mortises in one pass. If you have a benchtop machine, use a 3/8" bit and cut the mortises in two passes.

If you're building this particular bed, you need to pay extra attention to the mortises for the headboard. Make the bottom mortise so it fits tight around the tenon. But make the top mortise so there's 1/8" slop up and down. This allows the headboard to expand and contract without exploding.



Make the Pencil Posts

First lay out the taper on the four posts. The taper begins 27" off the floor and then tapers in 5/8" on all four sides.

Because I build so many beds, I made a template that lays out this taper without measuring. You can lay it out using a ruler and a long length of scrap.

Now cut this taper on all four sides using your band saw. Then clean up the saw blade marks by running each face of the post over your jointer.

Next you want to turn that four-sided tapered post into an eight-sided tapered post. The easiest way to do that is with a bearing-guided 45° chamfer bit in a hand-held router. First mark out the octagon shape on the top of the post and set the depth of your router's cut so it's just a little shy of the line. Now mark on all four corners of the post where the taper should end.

Make a test cut on the top of the post (you'll lose the top 1" later, so it can look a little sloppy) and



Clamp your self-centering doweling jig to the tenon and drill the long hole for the bed bolt (above). When it's complete, here's what it looks like (left).

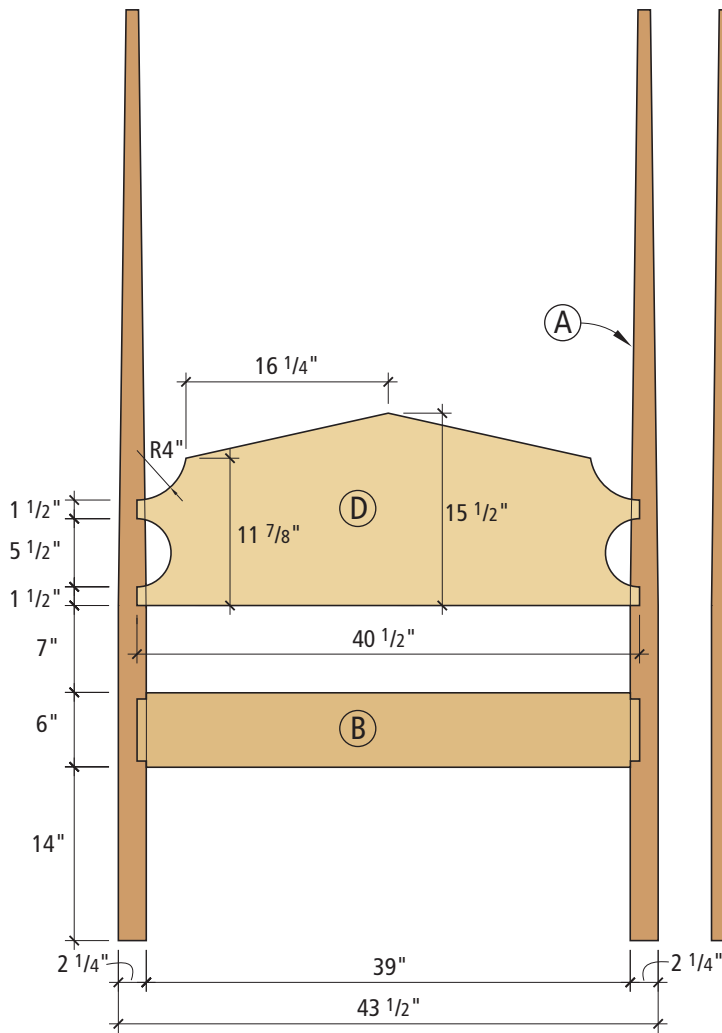

Elevation - headboard

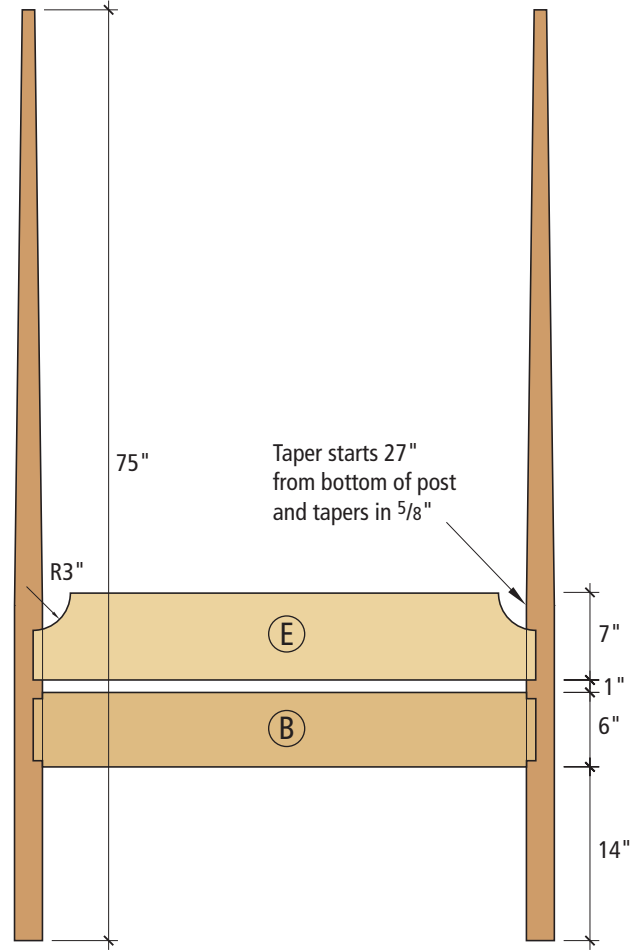

Elevation - footboard

PENCIL-POST BED

NO.	LET.	ITEM	DIMENSIONS (INCHES)			NOTES
			T	W	L	
4	A	Posts	2 1/4	2 1/4	75	
2	B	Short rails	1 1/4	6	40 1/2	3/4" x 5" x 3/4" TBE
2	C	Long rails	1 1/4	6	76 1/2	3/4" x 5" x 3/4" TBE
1	D	Headboard	3/4	15 1/2	40 1/2	3/4" TBE
1	E	Footboard	3/4	7	40 1/2	3/4" TBE

TBE = tenon on both ends

RECOMMENDED BED HARDWARE

Whitechapel Ltd., 800-468-5534, www.whitechapel-ltd.com
 Horton Brasses Inc., 800-754-9127, www.horton-brasses.com
 Ball and Ball, 800-257-3711, www.ballandball-us.com

- For bed bolts, I use a 6"-long steel bed bolt. In general, bed bolts have a 3/8" square head, a 1 1/16"-diameter flange and 16 threads per inch. You also will want to purchase a bed wrench that makes tightening and loosening the bolts easy. Call the companies above for pricing, shipping information and availability.
- For bed irons, I use 3" x 6" irons. These are made from 1/4"-thick steel that is 1 1/4" wide. Use three irons on each side rail for full, queen or king sizes. Use at least two irons on each side rail for a twin mattress.



Cutting the recess for the nut is easy if you make a jig for your router. The jig simply is a piece of $\frac{1}{4}$ " ply and some $\frac{3}{4}$ " scraps that limit the travel of the router.



Again, a simple jig helps me rout the mortises for the bed irons (left). Then it's a simple matter of screwing the irons to the rails (above).

SUPPORTING THE MATTRESS AND BOX SPRINGS

Essentially, there are five common ways to support your box springs or mattress. If you're building a king-sized bed, you likely need a center support, too.

Bed Irons: This traditional and sturdy method is outlined in this article. Note that these work only with a quality box spring. Some inexpensive box springs aren't rigid enough.

Wooden Cleats: Screw $1\frac{1}{2}$ "-square cleats to the inside edge of all four rails and rest the box spring on those.

Angle Iron: Screw angle iron (or aluminum angle brackets) to the bottom inside edge of all four rails.

Cleats and Slats: If you're building a bed that won't use a box spring, screw square wooden cleats to the inside edge of all four rails and then screw 1 x 4s to the cleats 1" apart.

Cleats and Plywood: Screw cleats to the rails and then screw a piece of $\frac{3}{4}$ "-thick plywood to the cleats.

adjust the depth of your router bit until it cuts right to that line. Now chamfer all four tapered edges. Near the end of the pass, watch the bit and the line you marked on the corner. When the bit hits the line, turn off the router and make the next cut.

Before you finish up with the posts, it's best to cut the $\frac{7}{16}$ "-diameter clearance holes for the bed bolts in each post. For the bolts that go into the long rails, drill the hole centered on the post and $\frac{1}{2}$ " above the center of the mortise. For the bolts that go into the short rails, drill the hole centered on the post and $\frac{1}{2}$ " below the center of the mortise.

By following these instructions, the head of the bed bolt will sit proud of the post. If you want to recess it, you will need to cut a 1" countersink that's $\frac{5}{8}$ " deep before you drill the clearance holes. Then you'll need to pick out some bed-bolt covers and drill a little deeper into the rails.

Now cut off the top 1" of all the posts and finish sand them. I usually start with 100 grit and proceed up to 180 grit.

Bed Bolt Basics

Cut all your rails to length. The cut list is for a twin-sized bed, but

you can use the accompanying charts to accommodate other mattress sizes.

Now cut the tenons on the rails. All of the tenons are $\frac{3}{4}$ " thick, 5" wide and $\frac{3}{4}$ " long. Clamp the rails and posts together and mark the locations of the clearance holes on the tenons using a pencil. Take the bed apart and get ready to drill the clearance hole for the bed bolt.

I use a self-centering doweling jig with a $\frac{7}{16}$ " bushing to drill the holes for my $\frac{3}{8}$ "-diameter bed bolts. If you don't have a $\frac{7}{16}$ " bush-

ing, a $\frac{3}{8}$ " will work, too. Bore the hole 4" deep into all the rails.

Now you want to cut a slot that will hold the nut for the bed bolts. The easiest way to do this is with a router. I set up a template guide in my router and made a template that would rout a $\frac{1}{2}$ "-wide slot that's 1" long. Chuck a $\frac{1}{2}$ " upspiral bit in your router and clamp the template in place. I routed this slot $2\frac{1}{4}$ " from the shoulder of the tenon. Cut the 1"-deep slot in several passes.

DEDICATED BED-BOLT JIG

I build a lot of beds, and I always use bed bolts. For years I used a doweling jig to drill the holes for the bolts in the rails – the technique I show in this article. It works well, but there is (as always) a faster way.

One day I was eyeing my drill press and it came to me. I bought an inexpensive radial drill press and built a simple plywood cabinet to hold the machine on its back. Now I have a simple horizontal boring machine. A fence and a holddown clamp keep the rails in place as I bore the holes. This setup has saved me loads of time. It's not the kind of rig you would want for a home shop, but it's proof that you can jig up just about any operation if you give it enough thought.



Now assemble the joint and snug the bed bolt. When everything looks good, fill the recess with hot-melt glue. Let the glue dry for an hour and then remove the bolt. The glue will hold the nut in place when assembling and disassembling the bed.

Bed Irons

In my opinion, bed irons are the best way to hold the box spring in place. The irons are simply "Ls" manufactured from 1/4"-thick steel. You can purchase them in a variety of lengths (pre-bent), from 3" long to 10" long.

The length of iron you use is determined by the thickness of your box spring. When the bed is assembled, you want the top of the box spring flush with the top of the rails. For this bed, 6" irons were in order.

You'll probably notice in the photos that when the bed irons are installed they actually will hang down below the rails by 3". This is not a mistake. The bed skirt covers the irons.

I put three irons on each long rail. One iron goes in the center and the other two are 12" from the ends of the rails.

You need to cut a shallow 1/4"-deep mortise for each bed iron. I again made a template for my router and used a straight bit. The template produces a mortise that is 1 1/4" wide and 3" long. Rout the mortises and install the bed irons.

Remove all the hardware and sand your rails up to 180 grit.

Headboard and Footboard

Glue up the panels you need for the headboard and footboard, cut them to shape on the band saw and sand them up to 180 grit.

You've probably noticed that the tenons on these two parts don't have any shoulders. This is a traditional look. If you want to make you headboard out of thick-



To hold the nut in place while screwing the bed bolt in place, I use one of those telescoping-antenna gizmos with a magnet on the end. If you aren't recessing your bolts in the legs, you don't have to use a bed-bolt wrench to tighten the bolt; an adjustable wrench will do fine.

er stock and cut shoulders on your tenons, that's OK by me.

Break the sharp edges on all the parts using sandpaper and get ready for finishing. I used a red water-based aniline dye on this project followed by a couple coats of lacquer. Cherry will oxidize over time, so a dye or stain is really optional in my book.

When you assemble the bed, make sure not to overtighten the bed bolts. I tighten them until the posts stop wiggling. After every season or two, it's a good idea to check the bolts to make sure they're still snug. This will ensure your bed frame will stay rigid for years to come. **PW**

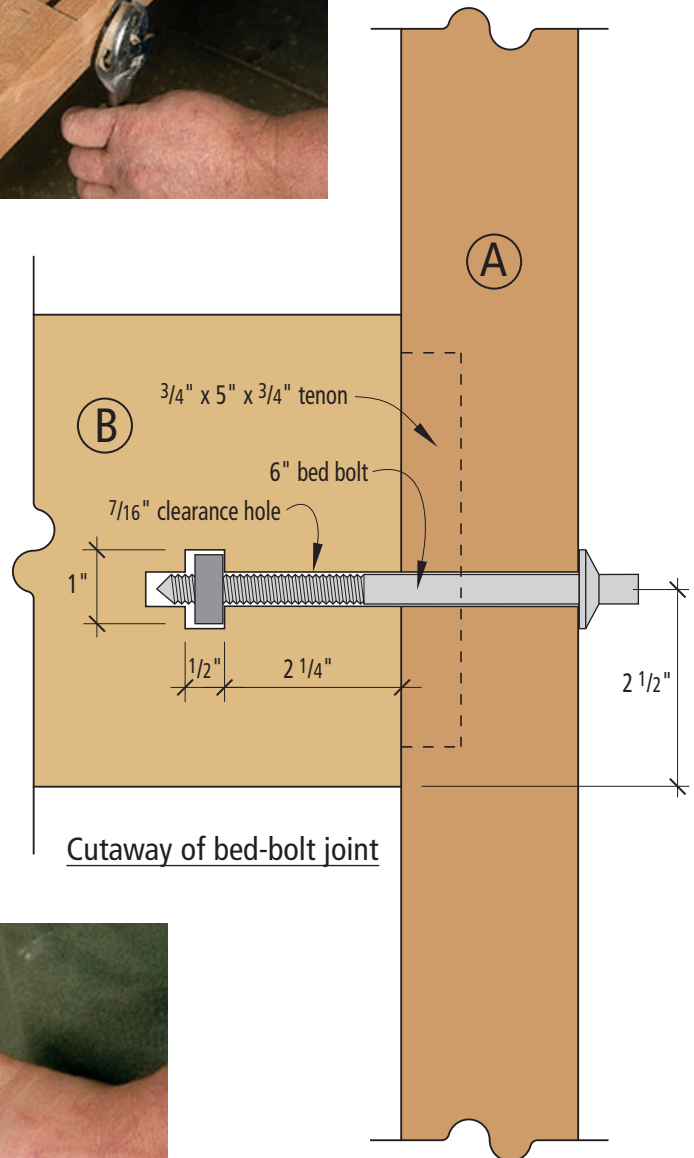

Cutaway of bed-bolt joint



With the nut and the bed bolt in place, fill in the recess with hot-melt glue to keep the nut in position for years to come.

ARTS & CRAFTS

Globe Stand

Nothing decks out your library like a proper globe stand.
And if you don't like this design,
we've got three others that might do the trick.

As was the case with most Americans, my world became a larger place last fall. I began to realize that I had only a vague notion of the location, size and geographical relationship of many of the countries whose names dominated the nightly news. Since I always had a problem with the Mercator projection maps that colored the walls of my high-school classrooms (is Greenland really as large as the United States?) I knew that a globe was the only thing that would give me a clear understanding of what's what and where.

When I visited my local map store, the globe-stand selection ran the gamut from traditional nautical themes to modern metal sculpture. What I was really looking for, a simple Arts & Crafts-inspired piece, was lacking from the lineup. I decided that the only way that I would be happy with the new addition to my living room was to buy a globe separately and come up with my own base.

Paging through a few of my Arts & Crafts books, the taboret (essentially a small table) appeared to be a staple of the founding fathers of the movement.

by Dan Brody

Dan Brody, a home improvement contractor in Columbus, Ohio, is concentrating on some improvements to his own home. As with many woodworkers, he has found the simple elegance of the Arts & Crafts movement to be a source of inspiration.



You might prefer a tapered-leg taboret with wedged tenons...



...or a globe stand in the style of Frank Lloyd Wright...



...or even in the style of a Gustav Stickley end table.





Use the plans from the diagrams to lay out your mortises on your top pieces. Draw the mortise locations on paper, photocopy the plans and use rubber cement or a spray adhesive to attach them to your wood. Then it's simple matter of cutting where the lines tell you to.



After you've cut your top to size, you need to clean up the band-sawn edges using a router table, a straight bit and the shop-made jig shown here. First cut a piece of 1/4"-thick plywood to the same size as your top and attach it to the top using a spray adhesive. Nail the center of the 1/4" plywood to a sub-base of 3/4" plywood. My router table is part of my table saw setup, so I attached a miter bar to the 3/4" plywood, which allowed me to slide the jig into position. If you don't have a miter slot, you might need to first clamp the jig in place and raise the router bit while it's running to get your cut started.



Once you get the outside shaped perfectly, you can use that edge to guide your router. I used a commercial edge guide (the Micro Fence, www.microfence.com). Essentially, two rounded guides ride along the outside edge of the top, ensuring the straight bit cuts a perfectly circular path. You also could make this cut using a commercial or shop-made circle-cutting jig for a router.

From Limbert to Mackintosh, Stickley to Wright, there always seemed to be room for yet another small table. With all its variations, it was the perfect starting point for a globe stand. With a little stretching here and a little cutting there, I soon had enough designs to house a galaxy, or at least a small solar system, of globes.

The Stickley variation that I

finally built incorporates a lot of the "tricks" – through-mortises, half laps, chamfered and pegged through-tenons, pyramids, and corbels. As it turned out, it was a great project for developing my Arts & Crafts joinery skills. Because all the parts are small, and a limited amount of material is involved, I didn't become suicidal when a mistake condemned a piece to the kindling bin.

I strayed from the quarter-sawn white-oak norm and chose to use cherry

to build the stand. Aside from cherry's tendency to scorch when being cut, it's a pleasure to work, easy to finish and, in central Ohio, the price is right.

Around the World in Four Easy Pieces

Start by laying out the four top quadrants. With the exception of the legs, all the parts for this project are sized to be cut from 1 x 6 stock. Before turning to your band saw to test your eye/hand coordination on the outside curves,

cut the 1" x 1" mortises. They're easier to form when there are still flat sides to press against a fence.

While splined joints might have been another "trick" that I could have thrown into the mix, I opted for the ease and familiarity of biscuits when assembling the ring. After gluing up the ring, cut the arcs slightly wide of the line on the band saw. I used a shop-made circle-cutting jig on my router table to refine the outside edge. Then I used a router edge guide to trim the inside edge to a perfect circle.

I also used biscuits to join the two halves of the lower table. I added another level of detail with a 1/4" x 1/4" chamfer on the top edge of both the ring and table. Finally, I plowed two 1/4"-deep x 3/4"-wide grooves that crossed in the middle of the bottom of the table to position it squarely on the stretchers.

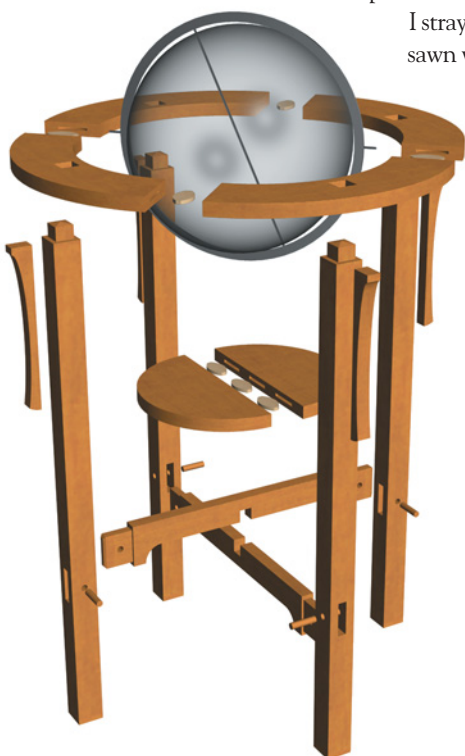

Though there are many complicated ways to attach corbels to legs, I prefer to simply glue and clamp them in place.



Here's a close look at the notches in the top that hold the pins on the globe.

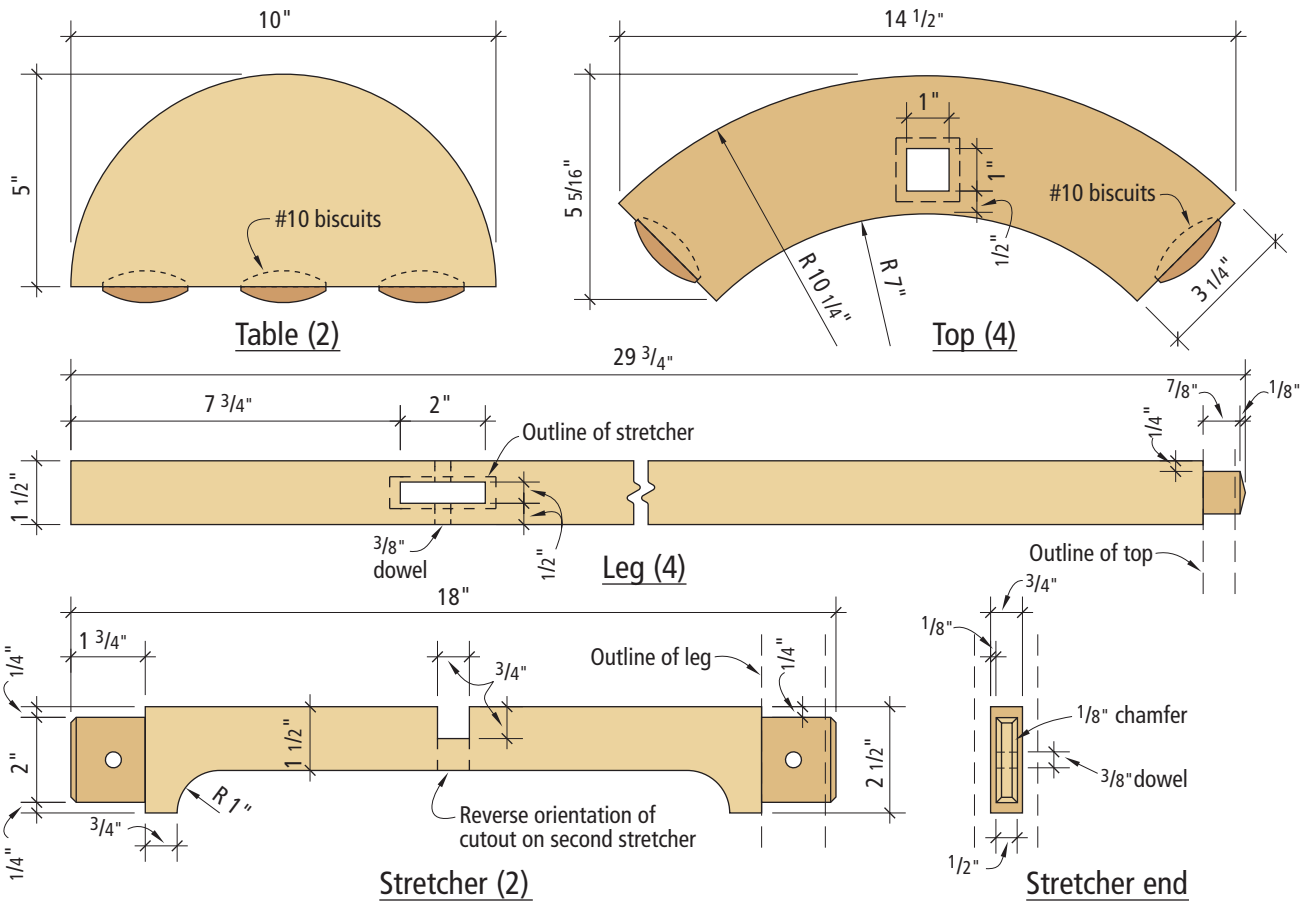

The legs are formed from 2 x 2 stock. Although the 1/2" x 2" through-mortises were made on the legs with a straightforward series of cuts with a 1/2" mortising chisel, the through-tenons required some attention to detail. After cutting the tenons on the ends of the legs to fit the mortises, I determined that a 14° bevel would give me an 1/8"-high pyramidal top. The tenon is sized to allow for an 1/8" vertical rise above the top before transitioning into the slopes. I like the look, and it's more forgiving than trying to align four pyramid bases exactly with the tabletop.

The stretchers are joined with

a simple half lap. The ends of the through-tenons are chamfered at a 45° angle. I then pegged each tenon using 3/8" cherry dowels through 23/64" holes after slightly tapering the ends of the dowels. With the holding power of contemporary glues, they're only for show anyway.

Speaking of show, the corbels that "support" the top are structurally unnecessary to this project. Visually, however, they're the icing on the cake. Glue them in place and clamp them up.

To mount the globe on the stand, you need to cut two 1/4"-long x 1/4"-deep notches in the inner edge of the ring. Rather

than setting up my router and a jig for the operation, I chucked a 1/4" Forstner bit into my drill press, made a 1/4"-deep hole that was tangent to the inner edge, and squared up the bore with a sharp utility knife. See the photo at left for details.

Because cherry darkens quickly enough through oxidation and exposure to ultraviolet rays, I used a clear wipe-on oil finish to emphasize the contrast between the end grain of the through-tenons and pegs and the face grain of the legs and top. If you've got 'em, you might as well flaunt 'em. **PW**

ARTS & CRAFTS GLOBE STAND

NO.	ITEM	DIMENSIONS (INCHES)			MATERIAL
		T	W	L	
4	Top pieces	3/4	5 5/16	14 1/2	Cherry
2	Table pieces	3/4	5	10	Cherry
4	Legs	1 1/2	1 1/2	29 3/4	Cherry
2	Stretchers	3/4	2 1/2	18	Cherry
4	Corbels	3/4	7/8	9	Cherry

SUPPLIES

Popular Woodworking readers can order this 12" antique globe for \$70 (a 10 percent discount) plus shipping (and sales tax if you live in Ohio).

Contact:

The Map Store
5821 Karric Square Drive
Dublin, OH 43017
614-792-6277

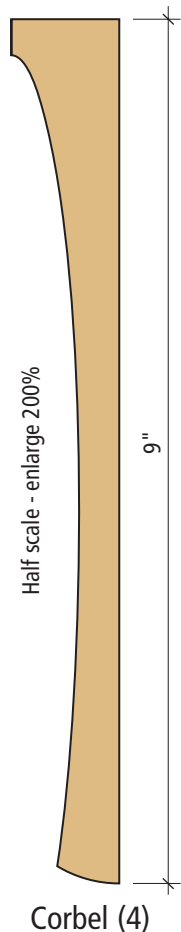

PREMIUM MID-SIZE PLUNGE ROUTERS

Versatile, precise and powerful, these routers are perfect for a single-router shop.

When you're shopping for the one router you'll use all the time, go straight for the mid-sized plunge router. It's powerful enough for most of the large profile bits, yet it's manageable in size, highly adjustable and maneuverable when it's out of your router table. For the most part, these routers are designed to excel in router tables and hand-held operations.

by David Thiel

Comments or questions? Contact David at 513-531-2690 ext. 255 or david.thiel@fwpubs.com.

While there are many quality plunge routers with big 2½- and 3-horsepower motors, their bulkiness has made them more the choice for exclusive use in router tables. For finesse, free-hand use (or as a router table router) the 1½ to 2 hp plunge routers fit the bill with a light touch and versatility.

The four premium routers we've tested here go a step further by offering extreme precision with their micro-adjustment mechanisms. Most garden-variety plunge routers have a turret depth stop with an adjustable rod to set the depth of your cut. These premium routers add a fine adjustment feature to this system, which increases the ease of adjustability exponentially.

There are other mid-sized plunge routers available, but we excluded plunge routers that would accept only ¼"-shank bits. While these tools are useful, we think



that if you're going to buy a machine with this much flexibility and power, it should accept bits with a 1/2" shank.

Additionally, we didn't test the Craftsman's mid-size premium plunge router because it's being redesigned and will be significantly different from what's in stores now. We'll bring you information on this new router in a future issue.

Seven Important Features

Premium plunge routers have a lot of features, and what's important is how all these work together to make a router that is a pleasure to use or just a pain. The most important features are the motor performance, the ease of adjusting the tool, the ease of plunging action, the feel of the tool in use, the switch, and the tool's ability to accept accessories such as template guides and vacuum hoses. Another feature is the self-releasing collet.

Rather than have the bit drop out after applying the "break-loose" pressure, these collets have a secondary stopping point that requires minimal pressure to release the bit, making it easier to remove the bit without danger of damaging it.

Many of these features are subjective, but the opinions in this article are from woodworkers who have decades of experience with routers and still use them on a daily basis. The motor performance and the plunging action were able to be more objectively tracked.

How We Tested Each Tool

For performance, we mounted a new 1/2"-diameter straight bit (carbide-tipped Viper bits from Oldham) in each router and mounted each in a router table. We cut multiple 1/4" x 1/2" rabbets in red oak and monitored the rpm and amperage draw before the cuts (these results are listed as



Dust collection is critical when using a hand-held router. The DeWalt has a unique collection system that pulls dust from within the base and then up through the plunge column. The Porter-Cable router also pulls dust through the base, but the vacuum port is on the base itself.

"no load" in the chart) and during the cuts (listed as "load").

The boards were fed by hand at a typical speed for this procedure. Because we weren't able to control the feed rate perfectly, the information in the chart on the following page is of a wider range than we would have preferred, but we've reported the averages from several cuts.

As to how easy it was to plunge each tool, we rigged up some simple free weights in a sling under the router to allow us to determine the weight necessary to initiate the plunge action, and the weight necessary to completely compress the plunge spring. By adding this information to our personal opinions of the plunging action for each router, we then ranked each tool.

Accessories

Dust collection and the ability to accept template guides were two of the major accessories that we took into consideration.



The micro-adjust depth setting on the Porter-Cable adjusts to 1/128" and allows the router to be adjusted up and down when the plunge lock is engaged. The Bosch uses a similar "locking" adjustment, while the DeWalt and Makita use a set-and-repeat adjustment system, which is not as sophisticated.

The DeWalt and Porter-Cable routers had built-in dust collection features, pulling dust through the base of the router. The Bosch router comes equipped with a dust hood that connects to the base and the Makita essentially offers no on-board dust collection.

Another useful accessory are template guides. The DeWalt, Makita and Porter-Cable routers all accept a standard 1 3/16"-diameter Porter-Cable guide. With the DeWalt and Porter-Cable you need to screw in a provided insert to use the template guides. On the Makita, the template guides attach right to the base. The Bosch router requires a proprietary guide set from Bosch.

Conclusion: DeWalt

We recommend the DeWalt DW621 as the best premium mid-sized plunge router. In close second is the Bosch 1613AEVS, which has the superior micro-adjust mechanism and is the best tool for use in a router table.

We were less impressed with the Makita RP1101. While the motor performed well and plunged smoothly, it fell short in features and carries the heftiest price tag in the test. Also disappointing was the Porter-Cable 7529, which had a flawed micro-adjust mechanism, and it suffered from poor motor performance.

BIT SPEED

One of the features of all these routers is variable speed. Adjusting the revolutions per minute allows different diameter router bits to perform their best. In general, the larger the bit diameter, the slower the speed. This makes the motor labor less and increases the life of the router and the bit.

Diameter	Speed (rpm)
1/16" - 1/2"	22K +
1/2" - 1 1/8"	14K - 18K
1 1/8" - 2 1/2"	12K - 14K
2 1/2" and up	8K - 12K

BOSCH 1613AEVS: AN OLDER DESIGN, BUT STILL PRECISE, QUIET AND POWERFUL

Without question, we voted this router the winner in the "precision" category. The Bosch's micro-adjust system engages quickly and provides finesse in .004" increments. Of the routers tested, only this tool and the Porter-Cable were easy to work with in a router table, with the Bosch having the superior height-adjustment system. The motor performance also was good, with a small drop in rpm under load and the least noise in the test. The eight-position turret offers multiple adjustable depth settings. A couple drawbacks include a return spring that was tighter than we prefer, which made it harder to start and complete the plunge motion. Plus, there is no way to lock the plunging mechanism open other

than holding the plunging lever back with your thumb. The router accepts only Bosch template guides, and the included dust collection insert doesn't work as well as the DeWalt and Porter-Cable systems. Overall, the Bosch router was a close second in our test. Despite the age of this machine, this router continues to perform and even excel over its younger counterparts by many measures. Priced at \$200, it's our preference in the category if you plan to use it in a router table.

For more information, contact Bosch at 877-267-2499 or www.boschtools.com.



DEWALT DW621: SIMPLE AND STOUT WITH GREAT DUST COLLECTION

The European-style DW621 turned a lot of heads when it was introduced six years ago, and its features continue to make it our preference for hand-held plunge operations. The dust-collection system keeps things clean without getting in the way of your work. The DW621 feels the most compact of any of the routers tested, but the motor still performs well (it was, however, the loudest in the test). The DeWalt is the only router tested that doesn't use a lever to release and lock the plunge mechanism. You simply turn the left handle to engage the smooth operating and responsive plunging mechanism. This mechanism also allows the plunge action to stay unlocked for easier setup. One area where

the router did not excel was its micro-adjust mechanism. The micro-adjust requires you to set the bit flat to the work surface, then dial in the cutting depth on the depth stop. This system works, but it pales in efficiency compared to the Bosch and Porter-Cable systems. Also, engaging the trigger on the handle requires some practice. We also felt that base was a little small and provided less support than we would prefer. Overall, the DW621 is a strong, versatile router with some excellent features and only a little room for improvement. A winner.

For more information, contact DeWalt at 800-433-9258 or www.dewalt.com.



MAKITA RP1101: SUPERB MOTOR, BUT LACKING ELSEWHERE

The RP1101 essentially is Makita's fixed-base router motor in a plunge base. The router provided good performance under load and had a good, responsive plunge spring, but the tool fell short elsewhere. The top-mounted switch provided decent switch access during router table operations, but during hand-held use it's necessary to release one hand while reaching for the switch, a less-than-ideal arrangement. It's the only router in the test that required two wrenches to change the bit, making bit changes more cumbersome. The micro-adjust system is similar to the DeWalt's, requiring set-and-adjust fiddling. While simple and accurate, it's unrefined compared to the Bosch and Porter-Cable. The round base provides stable support, but with a 1 1/8" -

diameter opening, the router is significantly limited in the size bits that can be used with the stock base. While the opening size does allow use of the standard template guide, we think that offering an adapter plate (as the competition does) is the better option. The router makes no provision for dust collection of any kind. The quality motor does offer external brushes for extended motor life, and this is the strongest feature on this router. While the RP1101 is a gutsy router, it's priced higher than the competition and seems overpriced for the features you get.

For more information, contact Makita at 800-462-5482 or www.makita.com.



PORTER-CABLE 7529: A GOOD IDEA WITH TWO MAJOR SHORTCOMINGS

This router should have been a strong contender, but it fell short in a couple important areas. While offering a good micro-adjust mechanism once engaged, it has the most complicated and time-consuming method to engage and disengage the mechanism. Once engaged, the micro-adjust was smooth and precise. The second disappointment was the motor's performance. The motor bogged down more easily than the other tools in our test. The 7529 does offer through-the-base dust collection, but it is far less convenient than DeWalt's. The plunge spring was tight, making the router less responsive in plunging action. We were pleased with the dual switches on the 7529, which allow you to

turn on the machine using either the switch on the top or on the handle. This makes the router easier to use in a router table. The collet lock made bit changing on this model easy, and the wide-diameter base opening allowed room for huge bits. While an adequate router, its shortcomings in the motor and micro-adjustment setup make it hard to recommend it compared to the competition. When you take into consideration the \$20 price difference between it and the Bosch and DeWalt routers, the Porter-Cable slips even further.

For more information, contact Porter-Cable at 800-487-8665 or www.porter-cable.com. **PW**



Premium Mid-sized Plunge Routers

	BOSCH 1613AEVS	DEWALT DW621	MAKITA RP1101	PORTER-CABLE 7529
Street Price	\$ 200	\$ 200	\$ 240	\$ 220
Motor				
Amps stated	12	10	11	12
Amps no load/load	5.1/9.3	5.5/9.2	3.5/10.8	4.4/8.1
RPM stated	11-22K	8-24K	8-24K	10-23K
RPM no load/load	21.6K/19.1K	27.1K/22.1K	23.8K/21.1K	21.5K/16.3K
Base				
Diameter	6 ¹¹ / ₁₆ "	6 ¹ / ₂ "	5 ³ / ₄ "	6 ¹ / ₂ "
Opening size	2 ¹ / ₁₆ "	2 ⁹ / ₁₆ "	1 ¹ / ₈ "	3 ¹ / ₂ "
Shape	D	Double-D	Round	D
Template guide	Bosch	PC, w/insert	PC	PC, w/insert
Edge guide centers	4"	3 ¹ / ₄ "	2 ³ / ₈ "	4 ¹ / ₂ "
Dust collection	w/adapt.	thru-base	NA	thru-base
Collet				
Self-releasing?	Yes	Yes	No	Yes
Spindle lock?	Yes	Yes	No	Yes
Bit changing ease (1-5)	4.2	4.2	2.8	4
Plunge Performance				
Micro-adjust quality (1-5)	4.8	3.9	2.6	1.4
Plunge control method	Lever	Handle/twist	Lever	Lever
Weight to start plunge (lbs.)	9#	6#	4#	4#
Weight to complete plunge (lbs.)	29#	17#	17#	30#
Plunge smoothness (1-5)	3.6	4	4.2	4
Plunge lock ease (1-5)	3.6	4.6	3.6	4
Max plunge depth	2 ¹ / ₄ "	2 ¹ / ₈ "	2 ¹⁹ / ₃₂ "	2 ¹ / ₂ "
Depth-stop method	8-pos. turret	3-pos. turret	3-pos. turret	3-pos. turret
Router Table Performance				
Height-adjust method	Precision knob	Turret stop	Turret stop	Precision knob
Height-adjust smoothness	Tight	Good	Tight	Good
Switch location	Handle	Handle	Top	Top or Handle
Overall				
Switch type	Trigger	Trigger	Toggle	Thumb trigger, toggle
Ease of switch (1-5)	4.6	4.8	2.8	3.5
db*	84db	104db	88db	91db
Weight	9.7 lbs	10 lbs	9.3 lbs	9.3 lbs
Ergonomics (1-5)	3.6	4.2	3.4	3.6
Cord length, material	9', P	8', R	9', R	10', R
Warranty	1 yr	1 yr	1 yr	1 yr

Key: On the 1-5 scale, 1=unacceptable, 5=excellent. P = plastic; R = rubber; * Decibels measured at 24" away from the router.

Tape Measures

Don't take this tool for granted. The right kind of tape is essential to accurate woodworking.

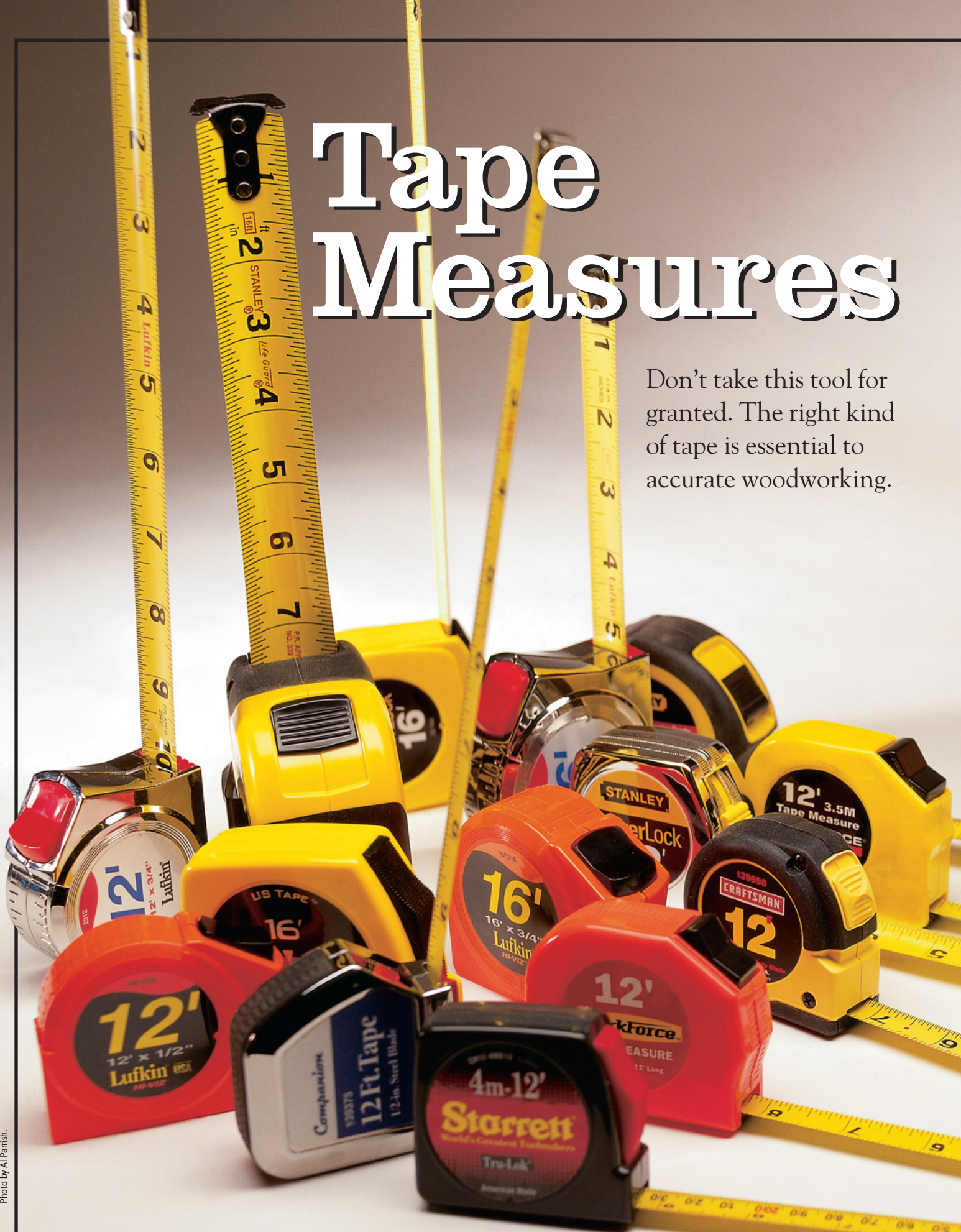

Too often we woodworkers are lazy when it comes to our tape measures. We use one designed more for carpentry or a tape with dimension lines that look like they were drawn on with a crayon. Or we never check the accuracy of the tool against a combination square.

If you've ever been vexed by a cabinet back that didn't fit like you expected or a door that didn't fit its opening, check your tape. Small errors really can add up with an inaccurate tape measure.

In the Store

First, of course, you need to buy the right tool. When you buy a tape measure for woodworking, here's what's important: Select a tape that is either 12' or 16' long at most. It's rare you'll ever need more than that in the shop. Make sure the tape you select has 1/32nd markings on the first 12" of tape.

If you measure results at the table saw with your tape (as opposed to a ruler or calipers) this is critical.

Don't buy the first tape off the rack. The quality of the printing on the tapes can vary from tape to tape. Look through several and pick the one with the finest lines.

"Standout" also is important. Standout is how far the tape will extend from its case before buckling under its own weight. We recommend 48" of standout for woodworking, so buy a tape with a 3/4"-wide blade. They're also more durable than 1/2" tapes.

In the Shop

When you get home, check your tape against your combination square – the benchmark of accuracy in most shops. Use a knife to strike a line about 6" in on a piece of scrap using your square. Then check that with your tape. If they don't agree, use your pliers to bend the hook at the end slightly until they agree.

Now check the tape to make sure it measures inside and outside measurements the same. Crosscut a piece of scrap and measure its length with your tape. Next, clamp a couple smaller pieces of scrap to either end of that board and measure the distance between those smaller pieces. The measurements should be the same. If not, tweak the hook some more.

To keep your tape reading as accurately as possible, never let

it retract at full speed. When you get near the end, slow it down before letting the hook hit the case.

These 13 tapes were the most common ones for sale at 10 stores in Kentucky and Ohio. After our evaluation, a couple rose to the top. Our "Editor's Choice" award goes to the Lufkin 12' 2312. The markings were excellent, and the case felt right in our hands. The "Best Buy" in the bunch is Stanley's 12' 33-312 PowerLock tape. **PW**

by Christopher Schwarz

Comments or questions? Contact Chris at 513-531-2690 ext. 407 or chris.schwarz@fwpubs.com.

HOW TAPES ARE MADE

Tape measures are a technical challenge to manufacture – especially the tape part. Many tapes are made using a technique usually called "flexigraphic" printing, according to industry officials at Stanley and Lufkin. Essentially there is a long rubber pad that's the length of the tape that is secured to a metal backing band, which prevents the rubber from stretching or distorting. The rubber pad is inked and it transfers the marks to the metal tape. Some tapes, usually shorter ones, are made using a rubber pad that is not backed by a metal band. Engineers insist that inaccurate tape measures are virtually unheard of these days, unless the tape is cut too long or too short.

13 Commonly Available Tape Measures

	STREET PRICE	TAPE WIDTH (IN.)	32NDS (Y OR N)	CLARITY OF MARKINGS (1-5)	COMFORT IN HAND (1-5)	INCHES OF STANDOUT	LOCKING METHOD	TAPE FINISH
Centerpoint 16'	\$15	3/4	No	2	2	49	TS	G
Companion 12' 39375	7	1/2	Yes	4.6	4	40	LL	M
Craftsman 12' 39698	9	1/2	Yes	4.3	4.6	41	TS	M
Lufkin 12' HV1012	7	1/2	Yes	4	3	35	TS	SG
Lufkin 12' 2312	10.50	3/4	Yes	4.6	4	58	TS	SG
Lufkin 16' HV1316	9	3/4	Yes	4.6	3.6	55	TS	SG
Stanley 12' PowerLock 33-312	7.50	3/4	Yes	4	4	69	TS	G
Stanley 16' LeverLock 30-986	7.50	3/4	Yes	3	2.6	65	LL	G
Stanley 16' FatMax 33-716	15	1 1/4	No	2	1.6	130	TS	G
Stanley 16' MaxSteel 33-692	10.50	3/4	Yes	2	4.6	70	TS	G
Starrett 12' Tru-Lok	10	1/2	Yes	3.6	3.6	40	TS	M
Task Force 12' 99933	4	1/2	No	2.3	2.6	45	TS	G
WorkForce 12' 848-539	3	1/2	No	2.3	2.6	42	TS	G

Key: TS= thumb switch; LL= lever lock; G= glossy; SG = semigloss; M= matte; On the 1-5 scale: 1=unacceptable, 5=excellent. Winners are labeled in red.



Parallel-jaw CLAMPS

These clamps aren't cheap,
so you should make sure you're getting
the most for your money.

by David Thiel

Comments or questions? Contact David at 513-531-2690
ext. 255 or david.thiel@fwpubs.com.

My first glimpse of a Bessey K-body clamp was on PBS's "The New Yankee Workshop." Like many viewers, I said: "I need some of those!" A few phone calls later, we were well on our way to populating the *Popular Woodworking* shop with our new-found loves.

That was about six years ago, and we've been surprised that there's been little competition in this category. Then, last year, Gross Stabil introduced an improved version of its parallel-jaw clamp, and Jorgensen introduced a new line of this same style. Both are aimed at Bessey. With three different parallel-jaw clamps in stores, we decided it was time to put 'em all in the shop to see how they stacked up.

Why Buy These Clamps?

First, what's a parallel-jaw clamp? Unlike traditional bar or pipe clamps, the parallel-jaw clamp has a flat and wide jaw surface that exerts even pressure along the length of the jaw. The even pressure starts all the way at the back of the jaw, against the bar, and continues out to the end of

the jaw mouth. This makes gluing up flat panels a cinch. You can rest the panel on the bar, providing a flat, supported glue-up surface. It also means you can glue up a box and put even pressure along the edge of the joint, rather than at just one point.

Another advantage of all these clamps is they rest flat on your assembly table as you glue up a panel – no rolling or tipping. And once your panel is clamped, you

can set the whole thing on end, and your glue-up will stand upright on the outside edge of the jaw. This frees up space on your assembly bench and allows you to keep working.

Details of the Test

To test the clamps, we simply put them to use. You may note that while we've included the reported clamping pressure for each clamp, we haven't compared or discussed this feature in the individual comments. Truth be told, too much clamping pressure will starve a glue joint. Suffice to say that all three of the models have more than enough pressure to perform any clamping task.

Our first clamping test was gluing up a simple, two-piece flat panel. The pieces were positioned to the inside of the jaws, lying on the bar. We looked for flex in the bars, as well as bowing in the panels during this test.

Next, we glued-up similar flat panels with the pieces lifted off the bar, held at the very tips of the jaws, unsupported by the bar. We used this test to look for bowing in the panel, and for any gapping at the joint caused by out-of-parallel pressure.

For a third glue-up, we cut two ½"-thick x 3" x 8" pieces of wood and clamped them end-to-end with the width of the pieces running the length of the jaws. We again checked for bowing and gapping at the glue joint.

One last test concerned durability. We dropped the clamps three times from workbench height to see if any damage occurred to the jaws. Finally, to test the durability in extreme shop conditions (or compressing years of use into a few minutes) we struck the most vulnerable corners of each jaw with an 18 oz. hammer three times with mixed results.

GROSS STABIL PC² CLAMP

Also made in Germany, the Gross Stabil PC² clamp is the company's second (and more successful) introduction into the parallel-jaw clamp category. The PC² clamp uses a high-tempered steel I-beam bar that looks a lot like the Bessey's; but on the PC², the teeth on the bar are on only the leading edge of the bar, not on all three faceted edges. The jaws on the PC² are essentially injection-molded high-density plastic forms that are reinforced internally with 1/4"-thick steel bars. The jaws have softer plastic, slip-on pads that are easily removable and replaceable.

The PC²'s head can be removed and turned around so you can use the clamp as a spreader. This requires using the outside surface of the top jaw and it isn't all that easy to do. Gross Stabil officials say that a next-generation design will have a fast-release mechanism and a lip on the top jaw so you can move the protective pad to the outside.

The locking mechanism on the PC² uses slip pressure from the malleable iron lower arm against the

toothed bar. The handle on the PC² is wood, measuring 1 1/8" x 4 3/4", with a spindle length of 2 1/2". The PC² is available in nine lengths from 12" to 100". The maximum clamping pressure reported by the company is 1,100 pounds. The jaw face measures 1 3/4" x 3 1/2", and a 48" clamp sells for about \$45.

The clamp performed well in all three of our clamping tests, exhibiting similar bar-flex in the end-of-jaw position as on the Bessey clamp. The jaw moved easily with little assistance, and it caught quickly when we allowed it to free fall – indicating quick operation with less chance of pinching your hand.

The Gross Stabil performed best of all three competitors for durability. The drop test showed no significant damage. During the hammer test we knocked the corner off one of the protective pads, but when we removed the pad and continued to abuse the jaw we were able to knock off just an 1/8" piece of lip, leaving the clamp in good shape and operable. This clamp is tough.



The hammer damage can be seen on the corner of the upper protective pad (pulled loose on purpose) and on the corner of the lower protective pad. The upper jaw shows the missing corner – essentially inconsequential damage (left).

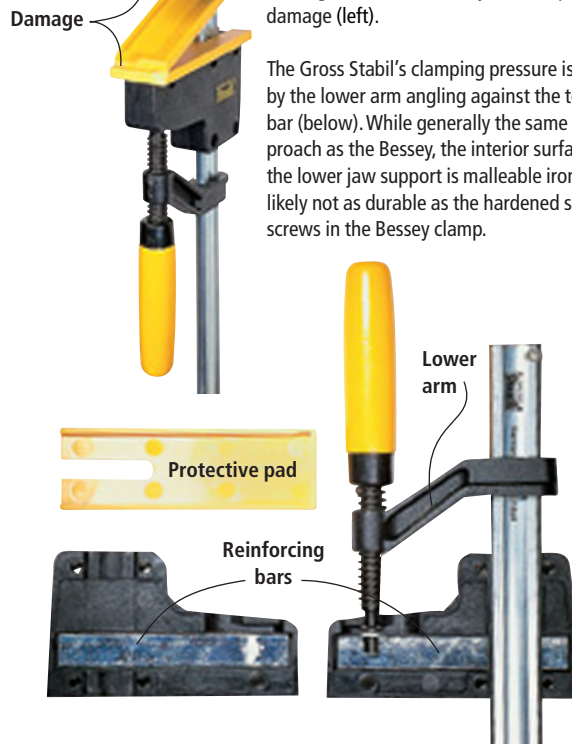

The Gross Stabil's clamping pressure is exerted by the lower arm angling against the toothed bar (below). While generally the same approach as the Bessey, the interior surface of the lower jaw support is malleable iron and likely not as durable as the hardened set screws in the Bessey clamp.

BESSEY K-BODY CLAMP

The K-body clamp was introduced in 1985 and has experienced only minor changes since then. Made in Germany, the clamp consists of a bar that is a hardened I-beam, a head made from sheet steel and jaw mechanisms made from cast steel. The jaws are covered with a high-density plastic. The clutch mechanism (which provides the pressure for clamping) uses the binding pressure of the jaw body against the bar. This is supplemented by teeth on three facets on both long edges of the bar and replaceable hardened steel screws mounted to the inside surface of the jaw body. The wooden handles measure 1 1/8" x 4 1/2", with about 1 1/4" of spindle length. The K-body is available in eight lengths from 12" to 98". The stated maximum clamping pressure is 1,100 pounds. The jaw faces measure 1 1/2" x 3 3/8" each, and a 50" clamp costs about \$44.

The Bessey offered good performance in all three clamping positions. It showed less bar flex in the end-of-jaw clamping position than any of the other clamps in the test. However, the K-body's short spindle travel makes it necessary to readjust the clamp position more frequently.

The K-body held up without flaw to the drop test. In the hammer test we cracked both high-density plastic covers after three whacks, but the cracks occurred along the sides of the covers, not on the jaw face. So the clamp was still usable.

When we let the clamp head free-slide down the bar, it moved rapidly before stopping. This poses a potential for pinching your hands. In moving the head along the length of the bar, the teeth affected the smoothness of the travel, but this is a trade off for the quick grabbing capability of this well-made clamp.

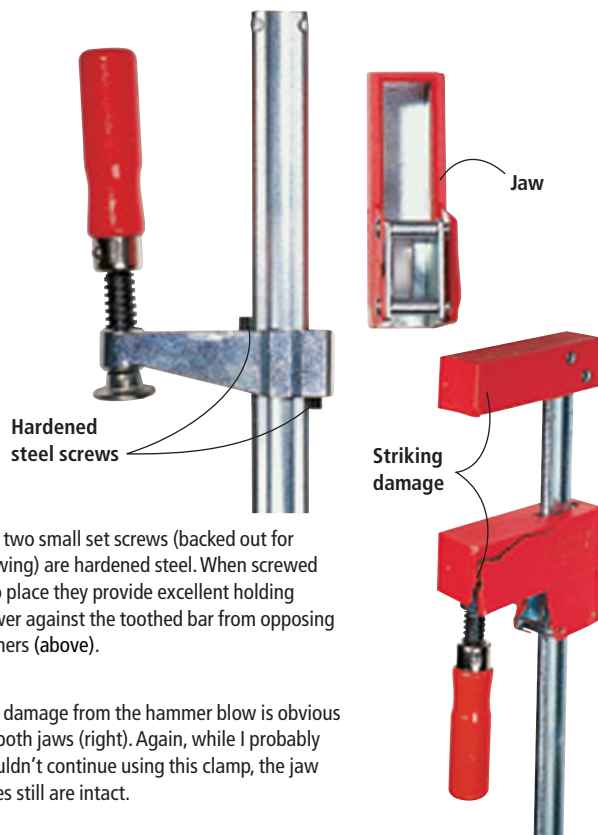

The two small set screws (backed out for viewing) are hardened steel. When screwed into place they provide excellent holding power against the toothed bar from opposing corners (above).

The damage from the hammer blow is obvious on both jaws (right). Again, while I probably wouldn't continue using this clamp, the jaw faces still are intact.

ADJUSTABLE CLAMP'S CABINET MASTER CLAMP

This is the newest entry into the parallel-jaw arena. Made in the United States by Adjustable Clamping Co. under the Jorgensen name, the bar appeared to be of softer steel than the other two clamps, formed into a figure-eight shaped cross-section. No teeth are cut into the bar. The heads are stamped steel pieces covered in plastic covers, which are peened in position on the underlying steel structure. The locking mechanism works similar to that found in the traditional Pony clamps from Adjustable, with four individual stamped steel plates angled against the bar and held in position by a piece of spring steel. When clamped tightly, the steel plates bite into the bar, making its own teeth. The handle on the Jorgensen Cabinet Master is maple, measures $1\frac{3}{8}$ " x $4\frac{1}{4}$ " and has a spindle length of $1\frac{3}{4}$ ". The clamp is available in six lengths from 12" to 48". The maximum clamping pressure reported by the company is 1,000 pounds. The jaw measures $1\frac{7}{8}$ " x 4", and a 48" clamp sells for about \$41.

There is a quick-release mechanism at the end of the bar to allow

the sliding jaw to be turned around to use the clamp as a spreader. An additional (and planned) benefit of the quick-release mechanism allows it to be used as a "kick stand" at the end of the clamp. This keeps the clamp from tipping when using longer clamps for a shorter application, where the weight of the bars lifts one jaw off the table.

As with the other clamps, the Cabinet Master handled the clamping tests well. The bar flexed more than its competitors in the end-of-jaw clamping procedure, but this still didn't gap the glue joint.

The heads moved smoothly during clamping, but reinstalling the head after removal for spreader functions required careful alignment. The clamp performed well during the free-fall test, protecting your hand.

The Cabinet Master didn't fare so well for durability. The plastic covers on the jaw mechanisms are brittle, and while they showed no damage during the drop test, both jaws shattered dramatically when struck once with a hammer, revealing the internal steel and making the clamp unusable.

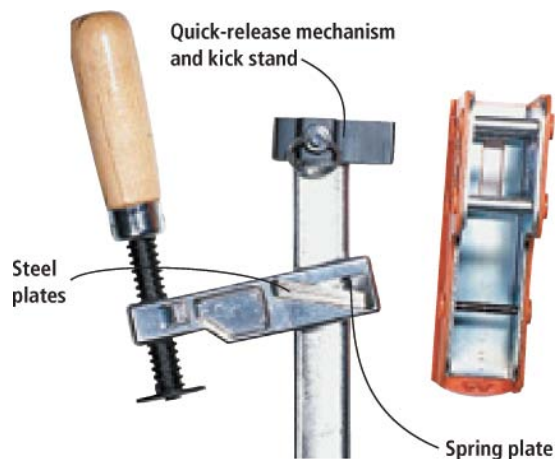

The Jorgensen's multi-plate clamping mechanism is similar to the traditional mechanism on a Pony clamp. Though it's hard to see, the plates are supported by a small V-shaped spring plate (above).



Here you can see the results of the hammer test (right). While the Bessey clamp has a similar covering shield, the material on the Bessey withstood more abuse.

Conclusion

During our real-world testing, all three of the clamps performed well for routine clamping procedures. The softer, non-toothed bar on the Jorgensen Cabinet Master holds well, despite material differences, but long-term testing will determine if this causes any problems. Though we had some minor concerns on the wear potential in the Gross Stabil's lower arm, this basic clamp design has been used by the company successfully for years. The Bessey's clamping mechanism is well-designed with good materials and has already stood the test of time in our shop.

As for the durability factor, we were disappointed in the Jorgensen clamp. While the abuse applied during testing was a little unusual, it wasn't outside the realm of possibility in a workshop. The Bessey clamp's cracked plastic also was somewhat disappointing, but it didn't make the clamps unusable, and in fact we continue to use similarly damaged clamps in our shop years after the damage. The Gross Stabil performance was impressive. Not only did the replaceable pad hold up fairly well, but the nearly indestructible performance on the inner jaw was very comforting.

The clamps all are priced very

similarly (within \$4 of one another), so price isn't a factor in announcing a winner. Because of durability factors, we're unable to give honors to Jorgensen. Between the Gross Stabil and Bessey, we consider the Gross Stabil to be a well-made clamp

with more features than the Bessey. Both perform well, and if you can find one brand a few dollars cheaper than the other, buy the less expensive one. But in an even price match, the nod goes to the Gross Stabil for durability, versatility and features. **PW**

CONTACT INFORMATION

Bessey K-body Clamps
800-828-1004 or www.jamesmorton.com

Gross Stabil PC² Clamps
517-279-8040 or www.grossstabil.com

Adjustable Clamp's Cabinet Master Clamps
312-666-0640 or www.adjustableclamp.com



Forrest Saw Blades

America's Best Since 1946!

"You Can Count On Us For Quality, Performance, and Dependability!"

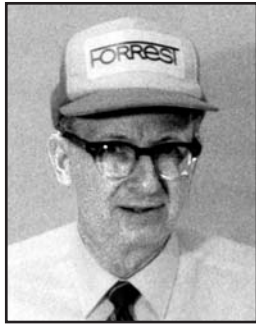

Jim Forrest, President

"When we established Forrest Manufacturing over 55 years ago, we committed our company to providing the very best products and services possible.

"Since then, demanding craftsmen have come to rely on us for the finest quality blades and dados. They also count on us for the best in-factory sharpening available anywhere.

"Forrest saw blades eliminate or reduce splintering, scratching, and tearouts.

We make them of high corrosion-resistant C-4 carbide to provide the longest possible life between sharpenings. We also hand-straighten them for perfect flatness and an astonishing +/- .001" runout that gives you peak performance. And Forrest blades feature exceptional perimeter concentricity and super fine tooth grind to ensure the highest quality edges.

"Our exclusive guarantee is another reason to have complete confidence in the products we offer! **Purchase any Forrest blade or dado and use it for up to 30 days. If you are not completely satisfied for any reason, return it for a full refund.** There's never any risk to you. You have my word on it!"

Woodworker II

ALL PURPOSE - table saws and portable circular saws.

	Sale Price	10% Off First Blade	15% Off Second Blade
12" x 40T x 1"	\$129	\$116	\$110
10" x 40T (1/8" or 3/32" K)	\$119	\$107	\$101
10" x 30T (1/8" or 3/32" K)	\$99	\$ 89	\$ 84
8 1/4" x 40T (3/32" K)*	\$99	\$ 89	\$ 84
8" x 40T (3/32" K)	\$99	\$ 89	\$ 84
7 1/4" x 30T (3/32" K)	\$89	\$ 62	\$ 59
5 3/8"x40Tx10mm (5/64" K)**	\$89	\$ 80	\$ 76

Also available: 14"x40Tx1" • 14"x30Tx1" • 12"x30Tx1" • 9"x40T • 9"x30T • 8"x30T(3/32"K) • 6"x40T(3/32"K). Call for prices.

The 10"x40T earned the Editor's Choice for the best performance regardless of price. American Woodworker April 1998, pp 68-69.

*For Sears & Makita **For DeWalt Cordless Portables

New! Customized Woodworker II

For the advanced table saw operator. Ideal for joinery and special uses!

	Sale Price	10% Off First Blade	15% Off Second Blade
10" x 40T (1/8" K) #1 grind for square cut box joints.	\$130	\$117	\$111
10" x 40T (1/8" K) #6 grind for near flat bottom, easy feed.	\$130	\$117	\$111
10" x 40T (1/8" K) Dovetail joint grind. Specify angle & left or right points. See Fine WW12/01.	\$130	\$117	\$111
10" x 40T (5/64" K) Ultra thin kerf for precision work. Use stiffener plate.	\$130	\$125	\$118
10" x 20T (1/8" K) Fast feed rip for thick hardwood without burning, but finish is not smooth like WW11.	\$94	\$ 85	\$ 80

Dado-King

You get flat-bottomed grooves and no splintering—even when crosscutting oak plys and melamine. This award-winning set comes with six 4-tooth chippers (including 3/32" chipper), two 24-tooth outside blades plus shims. Cuts 1/8" to 29/32" grooves.

	Sale Price	10% Off First Set	15% Off Second Set
6" set	\$269	\$242	\$229
8" set	\$289	\$260	\$245
10" set	\$349	\$314	\$297
12" set	\$449	\$404	\$382

FREE \$21 value! 10" Blade Runner carrying case. Protects and holds up to 10 blades. Ships with 6", 8", or 10" Dado sets. Included free with your order!

Chop Master

Specially designed for sliding compound miter, miter-chop, and radial saws.

	Sale Price	10% Off First Blade	15% Off Second Blade
7 1/2" x 60T x 5/8" Makita Cordless Slide	\$105	\$ 95	\$ 89
8 1/2" x 60T x 5/8" Hitachi, DeWalt, Ryobi, Freud TR125	\$119	\$107	\$101
10" x 80T x 5/8" Delta, Bosch, Hitachi, Makita, Ryobi, AEG & all	\$139	\$125	\$118
12" x 80T x 1" Delta, Hitachi, Makita, B&D, Sears & all	\$149	\$134	\$127
15" x 100T x 1" Makita, Ryobi	\$199	\$179	\$169

Also available: 8 1/4" x 60T • 6 1/2" x 40T • 9" x 80T • 14" x 100T. Call for prices.

Duraline HI A/T

Cuts melamine perfectly. 220mm & 300mm available. Our best plywood blade.

	Sale Price	10% Off First Blade	15% Off Second Blade
10" x 80T (1/8" or 3/32" K)	\$159	\$143	\$135
12" x 80T x 1" (1/8" K)	\$184	\$163	\$154

14"x100Tx1" • 14"x80Tx1" • 16"x100Tx1" • 8" • 7 1/4" and others. Call for prices.

Woodworker I

Designed for radial arm or tablesaws—fine crosscut.

	Sale Price	10% Off First Blade	15% Off Second Blade
7 1/4", 8", 8 1/4" x 60T	\$109	\$ 98	\$ 93
10" x 60T	\$129	\$116	\$110
12" x 60T	\$139	\$125	\$118

Also available: 9" x 60T • 14" x 60T. Call for prices.

Two Easy Ways to Order

Call toll-free

1-800-733-7111

Visit our internet store

stores.yahoo.com/forrestman

(In NJ, 973-473-5236)

Fax 973-471-3333

Se habla español

Western Canada: Call Sharp Tech, Inc.

877-228-0908 • Fax 403-225-3767

Other Canadian sales: Call CMR - Ron

Collier 800-229-4814 • Fax 989-684-0402



DON'T SEE WHAT YOU NEED?
Call us for other blades and dampener discs!

\$15 OFF* OUR EXPERT BLADE SHARPENING!

Don't take a chance with micro-chipped edges on your expensive wood! Our in-factory sharpening preserves the life and performance of all types of carbide blades. In fact, Forrest Manufacturing represents the industry standard for fine quality sharpening. We process most orders in 3 to 5 days, and we'll give you \$15 IN DISCOUNT COUPONS* with your next order for any blade or dado you own! (Please include return UPS of \$7 + \$1 for each additional blade.)

FORREST

Forrest Manufacturing Company
457 River Road
Clifton, NJ 07014

* 3 coupons at \$5 each, use 1 coupon per blade.

© 2002 Forrest Manufacturing Company, Inc.

FREE SHIPPING—
All Orders Over \$275
Other orders, please add:
Saw blade - \$7 • Dado - \$9 • Stiffener - \$3



Shaker Press



Cupboard

Once used to help press linens, this beautiful Shaker reproduction serves as a showplace for any collection of china or pottery.

When I first discovered this cupboard in John Kassay's "The Book of Shaker Furniture" (University of Massachusetts Press), it jumped from the pages and begged me to build it. The original version that I built featured a blind-door cupboard, but a friend at a furniture show suggested I build it with glass doors. I followed her advice, and what a difference it made.

This piece originated in the Pleasant Hill, Ky., Shaker community in the late 1800s. It's called a press cupboard because its flat, sturdy construction helped to press the linens stacked neatly inside. With the addition of the glass doors, this piece becomes a showplace for any treasured collection.

Lower Section First

To begin, mill the parts for the lower case according to the cutting list. Then turn the legs using the diagram provided. If you're not a turner, I recommend you taper the legs on the two inside edges instead. The taper should begin 1" below the lower front rail and sides, and the legs should taper to $1\frac{5}{16}$ " square at the floor.

Now mark the layout of the mortises on the legs. Because the sides and back are wide pieces of solid wood, you should use a double tenon to accommodate seasonal wood movement. Next cut the $\frac{1}{4}$ "-thick mortises on the legs.

Don't forget to cut the mortises in the top and lower rails and back piece to receive the two rail supports and the two drawer runners.

If you're using a hollow-chisel mortiser, use the step method of cutting mortises – skip every other cut and return to clean out the sections between after reaching the end of each mortise. This will prevent excessive wear on your chisel.

Now cut your tenons on the table saw. I use a shop-made tenon jig, but a commercial jig will do fine. Test the fit of the pieces of the lower case. If everything works, proceed to finish sand your parts, and glue and assemble the lower section. First glue the front and back sub-assemblies, then finish by assembling the side pieces. Remember to install the rail support pieces at this stage.

Next, notch the drawer runners so they fit around the legs. Glue them into the mortises you cut in

by Glen Huey

Excerpted from "Fine Furniture for a Lifetime" copyright © 2002 by Glen Huey.

Used with permission of Popular Woodworking Books, an imprint of F&W Publications Inc. Visit your local bookseller or call 800-289-0963 to obtain your copy.

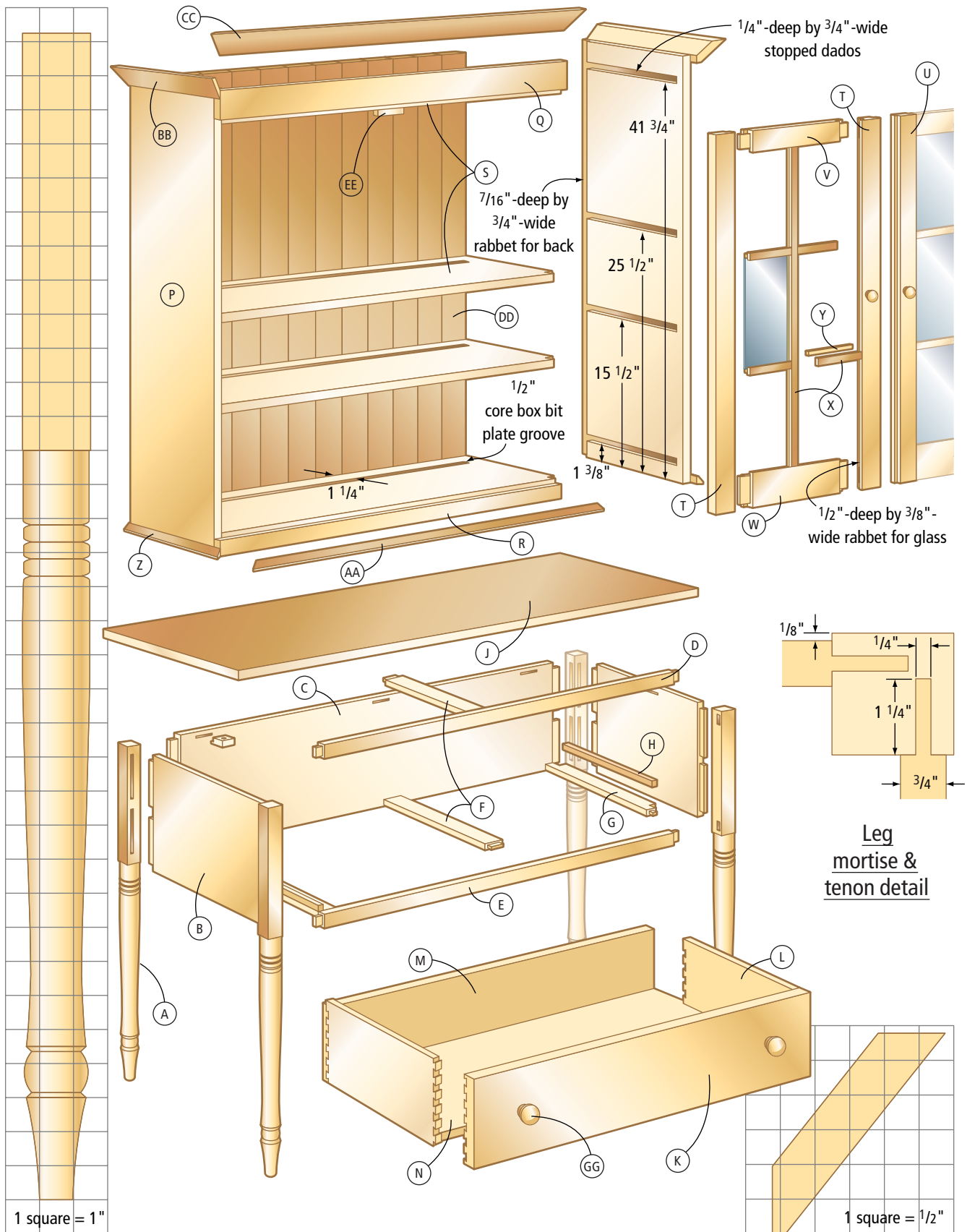

Illustrations by Len Churchill.

the lower front rail and nail them to the rear of the back leg. Nail the drawer guides to the runners, flush to the leg blocks.

Next build the drawer. The drawer front is flush with the face of the cupboard. You can see the layout of the hand-cut dovetails at right. I used half-blind dovetails at the front and through-dovetails at the back. The solid-wood bottom is a raised panel that fits into grooves in the sides and drawer front.

Once you've built the drawer, slide it into the lower section and align the drawer front with the case front. Then measure and cut the stops for the drawer. Attach

the stops with a screw and glue each to the back leg (see the photo on the next page).

Next remove the drawer, then lay out and drill holes in the legs and through the case's tenons for the square pegs. Set the pegs and cut them flush with the case.

Now glue up the boards you'll need for the top of the lower section. To attach it, I used shop-made wooden clips. I used a biscuit joiner to cut the recess in the sides, back and top front rail to accept the clips.

Upper Section Next

To begin the cupboard's upper section, cut your sides and shelves

Before I glued the drawer parts together, I ran the bottom edge of my drawer front over the jointer with the fence set at a 5° angle and the machine set to make a 1/16"-deep cut. This creates a slight bevel that allows the drawer to close without the bottom edge catching on the lower front rail.



Here you can see the layout of the hand-cut dovetails used to build the drawer.

Step photos by Glen Huey.

SHAKER PRESS CUPBOARD

NO.	LET.	ITEM	DIMENSIONS (INCHES)			MATERIAL	COMMENTS	
			T	W	L			
Lower Section Case Pieces								
☐	4	A	Legs	1 7/8	1 7/8	34 1/4	Primary wood	
☐	2	B	Sides	3/4	11	17 1/4	Primary wood	1 1/4" TBE
☐	1	C	Back	3/4	11	42 1/4	Secondary wood	1 1/4" TBE
☐	1	D	Top front rail	3/4	1 1/4	42 1/4	Primary wood	1 1/4" TBE
☐	1	E	Lower front rail	3/4	1 1/4	42 1/4	Primary wood	1 1/4" TBE
☐	2	F	Rail supports	3/4	2	18 1/8	Secondary wood	1/2" TBE
☐	2	G	Drawer runners	3/4	2 1/8	17 3/8	Secondary wood	1/2" TOE
☐	2	H	Drawer guides	1/2	13 1/16	14 5/8	Secondary wood	
☐	1	J	Top	3/4	20	47 1/2	Primary wood	
☐	1	K	Drawer front	7/8	8 3/8	39 5/8	Primary wood	
☐	2	L	Drawer sides	1/2	8 1/4	15 1/2	Secondary wood	
☐	1	M	Drawer back	1/2	8 1/4	39 5/8	Secondary wood	
☐	1	N	Drawer bottom	5/8	15 1/2	39	Secondary wood	
☐	2	GG	Wooden knobs			2	Primary wood	
Upper Section Case Pieces								
☐	2	P	Sides	3/4	12	45	Primary wood	
☐	1	Q	Top front case rail	3/4	5 1/2	39	Primary wood	
☐	1	R	Bottom front case rail	3/4	1 3/4	39	Primary wood	
☐	4	S	Top, bottom & shelves	3/4	11 1/4	37 3/4	Primary wood	
☐	3	T	Door stiles	3/4	3	37 1/2	Primary wood	
☐	1	U	Door stiles	3/4	3 1/4	37 1/2	Primary wood	
☐	2	V	Upper door rails	3/4	3 3/4	16	Primary wood	1 1/4" TBE
☐	2	W	Lower door rails	3/4	4 1/2	16	Primary wood	1 1/4" TBE
☐	4	X	Exterior door grills	1/4	3/4	30	Primary wood	
☐	4	Y	Interior door pieces	1/4	1/2	30	Primary wood	
☐	2	Z	Bottom moulding	5/8	1 1/2	16	Primary wood	
☐	1	AA	Bottom moulding	5/8	1 1/2	42	Primary wood	
☐	2	BB	Crown moulding	3/4	4	16	Primary wood	
☐	1	CC	Crown moulding	3/4	4	42	Primary wood	
☐	1	DD	Back boards	5/8	38 3/8	42 1/2	Primary wood	made in many pieces
☐	1	EE	Fixed door catch	3/4	1	3 1/4	Secondary wood	
☐	2	FF	Wooden knobs			1 1/4	Primary wood	

TBE=tenon both ends; TOE=tenon one end; Primary wood=maple; secondary wood=poplar

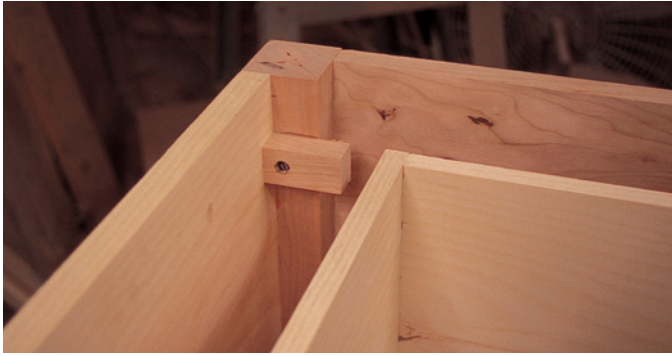

After you've built the drawer, slide it into the lower section and align the drawer front with the case front. Measure and cut stops for the drawer, then attach them with a screw and glue to the back leg as shown here.



Gang all the door stiles for the job and do the layout work in one step. This will increase your accuracy.

to size. Lay out and cut the $\frac{1}{4}$ " x $\frac{3}{4}$ "-deep dados for the shelves – use the diagram to lay out your dados. Note that these are stopped dados that don't extend through the front of the sides. Also, cut the $\frac{7}{16}$ " x $\frac{3}{4}$ " rabbet for the backboards. Notch the front corners of the shelves so they fit in the stopped dado cuts.

Next, using a $\frac{1}{2}$ " core box bit chucked in a router and another shelf as a straightedge, cut a plate groove into the back of the lower three shelves that's approximately $1\frac{1}{4}$ " from the back edge. Make sure to begin and end the cut just shy of the shelf ends.

Finish sand the shelves and the insides of the sides, then glue the unit together. Check for squareness by measuring the case diagonally from corner to corner.

When the glue is dry, add the square pegs through the sides and into the shelves as you did to the lower section.

Simple Mullioned Doors

For the doors, lay out and cut the mortises on the stiles. Because these are glass-pane doors, cut a $\frac{3}{8}$ " x $\frac{1}{2}$ " rabbet on the interiors of all eight door pieces.

Now cut the rails to finished size and get ready to cut the tenons on both ends. This tenon fits around the rabbet in the stiles. Here's how to make it: Set your table saw's blade height to $\frac{1}{4}$ " and define the tenons' shoulders on the face sides of the rails.

Next, move the fence $\frac{3}{8}$ " closer to the blade and define the shoulders on the back of the rails as well as the shoulder on the



Here's what the door stiles look like after cutting the rabbet for the glass.



This is how the tenoned ends look after you complete all the cuts.



Create a half-lap joint by marking the location on the latched door and creating a matching rabbet on the other door.

edge. Then finish the tenons by completing the necessary cheek cuts. Test fit all of the pieces and then assemble the door frames.

Now rout the mortises for the door hinges and install the hinges. Hang the doors. Now cut down the door stiles so they overlap $\frac{5}{16}$ " in the center. Remember to keep the stiles the same width.

One of these doors will open with a latching knob, and the other one will open using a release inside the cupboard. Remove the door that will have the latching knob and cut a $\frac{3}{8}$ " x $\frac{3}{8}$ " rabbet on the back side of its interior stile. Reinstall this door and

allow the rabbet to overlap onto the opposite door's stile.

Mark the overlap on the opposite door and cut a matching rabbet to produce the half-lap joint shown above.

Next, with the doors installed, mark the location of the top and bottom of each shelf on the door stiles. This will properly place the glass dividers on the door so they conceal the shelves when the doors are shut. Also mark for a $\frac{3}{4}$ "-wide vertical divider on the edge of the two rails of each door.

Now cut the long strips of $\frac{1}{4}$ " x $\frac{1}{2}$ " material for the interior dividers and the $\frac{1}{4}$ " x $\frac{3}{4}$ " strips for

the exterior glass dividers. With the door face down, fit and glue the interior horizontal pieces, allowing them to rest on the lip created by the rabbet cut on the inside of the door.

Flip the door so it's face up, and fit the long vertical exterior piece into the center of the opening. Glue this to the two previously installed pieces. These three pieces form the basis of the opening for the glass.

Cut, fit and install the remaining pieces necessary to complete the door. Then repeat the procedure on the other door.

Finishing Touches

When the glue in the upper unit is dry, mill the top and bottom

front case rails a bit longer than required, sand the insides and glue them to the sides of the upper unit. After the glue dries, drill and install square pegs through these rails. (By allowing the glue to dry, you reduce the risk of the wood splitting at the joint.) Cut the extra length flush to the case.

Now make the crown moulding according to the illustration. Set the blade of your table saw to 40° and make the first cut with the board face against the fence. The fence is set on the left side of the blade. Then, set the fence to the right side of the blade, and lay the face flat on the table saw in order to cut the complementary angle on the opposite edge of the board, achieving 90°.

Keep your table saw settings the same and cut the angle on the bottom moulding for the upper section. Sand both mouldings, progressing to 180-grit sandpaper.

Sand the outside of the case to 180 grit, then fit the crown moulding to the case and attach it with reproduction finish nails for an authentic look. Dowel the top edge of the crown moulding from the side into the front piece and sand it smooth.

Align the bottom moulding with the inside of the front and sides of the case. Make the 45° cuts at the front corners, square cut the back corners and attach with No. 8 x 1 1/4" slot-head wood screws into the sides. Glue and screw the moulding to the front.

Then dowel the front corners as you did on the crown moulding.

Cut the half-lap joints on the long edges of the back boards. Then finish sand the pieces.

On the door without a knob, install the catch. Using a biscuit joiner, cut a 1/4" slot in the bottom of the second shelf to accept the catch shown below. After finishing, align the catch with the slot and install with a No. 8 x 1 1/4" slot-head wood screw. Then make a latch (also called a turn) for the other door. It will latch against its neighbor's stile.

I used a reddish aniline dye to finish this piece. After the dye-job is complete, attach the top to the lower case using wooden clips and apply your protective top coat. I selected lacquer as the cupboard's finish.

Nail the backboards into place using reproduction nails, then install the glass in the doors. On this cupboard, I used Bendheim's light restoration glass (for more information, visit the company's web site at www.bendheim.com).

PW



The exterior glass dividers form the basis of the door's glass grid. The interior horizontal pieces rest on the lip created by the rabbet cut on the door pieces. The exterior vertical piece is fitted into the center of the opening and glued to the two horizontal pieces.



This is the catch for the door without a knob. It turns into a 1/4" slot in the bottom of the second shelf that you cut using a biscuit joiner.



This is what the latching knob looks like.

HARDWARE AND SUPPLIES

Door hinges, 2 pairs, 2 1/2" in length
Slot-head wood screws, No. 8 x 1 1/4"
1 1/2" shingle nails for backboards
1 1/2" fine finish nails for mouldings



This case is unusual in that you install the top and bottom case rails after assembling the case. They are applied to the front edge of the sides. Cut them long, glue them in place and trim them to fit.



Use water putty for installing glass panes into the doors. Water putty gives a yellowed look that simulates age. I use Durham's Rock Hard Water Putty.



RES

Have you ever planed a thick board to create a thin one? Each pass through the planer leaves you feeling guilty as you reduce a beautiful plank to a pile of shavings. You could've resawn the board instead and dramatically reduced the amount of waste. Resawing is the process of ripping a board through its thickness. It's a great way to extend your lumber budget when building diminutive chests, spice boxes, tea caddies or other scaled-down projects. But that's not the only use for resawing; you can even resaw a figured plank into veneer to create matching drawer fronts. Despite what you may have heard, resawing isn't difficult, but it does require that you carefully prepare by selecting the right blade and fine tuning your band saw. Read on and I'll go through the process, step-by-step.

Choosing the Best Blade

Successful resawing depends on having the best blade for the job. In fact, almost any band saw will accurately resaw when equipped with the right blade; yet the finest of band saws will spoil your prized board if equipped with the wrong blade. When making a selection, begin by choosing the blade width for your band saw.

Blade Width

Conventional wisdom says it's best to use a wide blade when resawing. This is true only if your band

SAWING

WITH THE BAND SAW

Here's how to choose the right blade, set up your saw and make the cut. Follow these simple instructions and soon you'll be slicing wood as thin as you please.

saw will adequately tension a wide blade. The problem is that the average 14" band saw just can't muster the force required to properly tension a $\frac{3}{4}$ "-wide blade. So the best choice of blades is one your band saw can tension. I've gotten great results resawing with $\frac{3}{8}$ " and $\frac{1}{2}$ " blades. Although this seems small for resawing, a narrow blade under sufficient tension performs much better than a wide blade with too little tension.

Selecting the Best Pitch

Pitch is the number of teeth per inch (TPI). Fine-pitch blades, those with a greater number of teeth, are the best choice for smooth cuts in relatively thin stock (less than 2"). In contrast, coarse-pitch blades, those with fewer teeth, are your best bet for resawing. It works like this: Behind each tooth is a space called a gullet. The gullets do the work of hauling the sawdust out of the kerf as the stock is cut. If the blade pitch is too fine, the small gullets quickly fill with sawdust and cutting slows dramatically. Also, the greater number of teeth that are

in contact with the stock at any given time, the more friction that's created at the tooth tip, causing overheating. Even worse, the blade may buckle and bow during the cut, distorting in the kerf and spoiling the stock.

To reduce vibration and increase the smoothness of the cut, manufacturers of band saw blades have begun to offer variable-pitch blades. As the name implies, the pitch of a variable-pitch blade changes repeatedly along the length of the blade. This unique tooth design limits the intensity of vibrations, resulting in a smoother surface that requires less cleanup. This is obviously a plus, especially when you are band sawing veneer.

Tooth Material

The teeth of a band-saw blade are subjected to tremendous heat and stress when resawing. Choosing the best tooth materi-

al dramatically affects the life of the blade. Contrary to popular belief, the heat is generated by friction at the tooth tip, not by the blade guides. If you've ever used a cabinet scraper to smooth a board, you know how quickly the edge heats up and burns your thumbs. The same phenomenon occurs at the cutting edge of a band-saw blade. So don't expect to keep the blade significantly cooler by switching to a different type of guide. Instead, use the money to purchase a better blade.

Unfortunately, ordinary carbon-steel band saw blades quickly lose their temper and consequently their edge when subjected to the heat from resawing. Carbide, when compared to carbon steel, has much greater heat resistance and will retain its sharp edge much longer. As an added benefit, carbide-tipped band saw blades leave the surface smoother, too. That's because the teeth are precisely

ground after brazing to the blade. Although you're sure to get sticker shock the first time you price a carbide blade, just remember that they're more economical in the long run. As a rule, even though a carbide blade will cost 10 times more than a steel blade, it will typically hold its edge 25 times longer.

Tooth Type

Flip through the pages of a catalog and you'll see that band saw blades are available in three tooth types: regular, skip and hook.



My favorite blade is this Lenox $\frac{3}{8}$ "-wide variable-pitch blade. It has a $\frac{2}{3}$ variable-tooth-pitch hook tooth that is carbide-tipped. It cuts smoothly and aggressively and lasts a long time. For more information on this blade, go to www.lenoxsaw.com or call 800-628-8810.

by Lonnie Bird

Lonnie Bird (www.lonniebird.com) is author of "The Bandsaw Book" (The Taunton Press). He builds period furniture and conducts woodworking seminars in Dandridge, Tennessee.

Blades with regular teeth are the most common, and they're the best choice for cutting smooth contours in stock less than 2" thick. But because of the great number of teeth, a regular-tooth blade is a poor choice for resawing. Remember: Too many teeth in contact with the stock causes greater friction and overheating. A better choice for resawing is the skip-tooth blade.

As the name implies, skip-tooth blades have fewer teeth and larger gullets than regular-tooth blades – every other tooth is skipped or omitted. This places fewer teeth in contact with the stock; as a result, the feed rate is faster, the large gullets of the blade effectively carry away the sawdust from the kerf and the blade runs cooler.

But, by far, the best choice for resawing is the hook-tooth blade. Like skip-tooth blades, hook-tooth blades have large teeth and

gullets, but the hook-tooth design has a positive-rake angle that cuts aggressively, yet smoothly. In fact, a hook-tooth blade is so aggressive that it will almost feed itself during the cut.

So what's the bottom line on blades for resawing? The best choice I've found is a $\frac{3}{8}$ "-wide variable-pitch blade from Lenox. It has a 2/3 variable-tooth pitch hook tooth that is carbide tipped. This blade cuts both smoothly and aggressively, and the carbide-tipped teeth will hold their edge for a long time. If this blade is just more than you're willing to spend, then check out the Wood Slicer from Highland Hardware (800-241-6748). It's also a variable-pitch hook-tooth blade. And although the steel teeth won't last as long as carbide, it's a good value, especially if you don't resaw often. Also, because of its thin kerf, it's a great choice when slicing veneer from expensive stock.

Tuning Your Saw

Once you've selected the best blade, you're ready to tune the band saw for top performance. Begin by backing off the guides and mounting the blade. Then adjust the blade tracking and tension. One of the most confusing aspects of tuning your band saw in preparation for resawing is finding the best blade tension. Some woodworkers pluck the blade and listen to the tone while others push the blade sideways and check the amount of deflection. To clear the air, I spoke with several blade manufacturers to get their recommendations. Here's what I found:

To resist the bending stress during resawing, band-saw blades require tremendous tension. In fact, blade manufacturers recommend 12,000 psi for carbon-steel blades and twice that for blades made from spring steel (carbide-tipped blades have a spring-steel body). Unfortunately, many 14" band saws simply won't tension a wide blade beyond about 10,000 psi. Despite this, you can still get great results if you equip your saw with a narrow blade. To prevent the blade from flexing in the cut, I tension the blade until the tension spring is fully compressed, and then back it off slightly. After resawing, I release the tension to relieve the stress on the saw's components.

Square the Table

Once the blade is tensioned, the next step is to square the table to the blade. To accurately slice thin sheets of veneer, the table must be positioned 90° to the blade. You can check this by resting a square against the blade. For greatest accuracy, position a lamp behind the square; the light will reveal any gap between the blade and the square. If necessary, adjust the table until it is square.

Adjusting the Guides

Remember: The type of guide you're using isn't nearly as important as having them correctly adjusted. Through the years I've used a variety of different guides and have found that all of them perform well when properly adjusted. And making the adjustment is easy. Let's begin with the thrust wheel, which is the technical name for the guide behind the blade.

The thrust wheel counteracts the forces of feeding the stock to prevent the blade from being pushed off of the wheels. When correctly adjusted (about .003" behind the blade) it spins only during cutting and will coast to a stop when the saw is running idle.

The guides that flank the blade help prevent sideways deflection during cutting. Like the thrust wheel, they should be adjusted close to the blade, approximately .003", but not touching. A dollar bill makes a convenient feeler gauge when setting the guides. However, if your band saw is equipped with bearing guides, they can be adjusted to contact the blade, but the constant spinning will cause them to wear faster, and I've noticed no notable improvement in the quality of the cut.

Set Up the Fence Next

With the guides and table adjusted, turn your attention to setting up the fence. Unlike a table saw's fence, setting up a band saw fence requires much more care. That's because most band-saw blades suffer from a phenomenon called drift. This simply means that they won't cut parallel to the edge of the table. Although some woodworkers may advocate a short convex fence to compensate for drift, this type of fence requires that you concentrate on a layout line and make continual adjust-

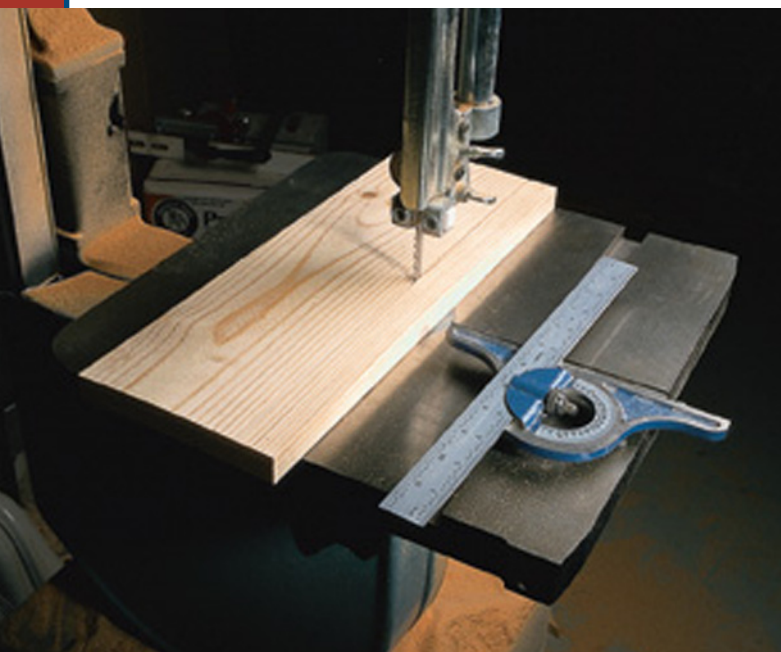

Set your fence for the drift of the blade. Take a piece of wood that's the length of your band saw's table and scribe a line parallel to one edge. Now cut along that line, compensating for the drift of the blade to get a straight cut. When you reach the middle of the board, turn off the saw. Leave the board at the angle you had to turn it to get a straight cut. Now measure that angle with a protractor or sliding T-bevel. When you clamp your resaw fence to the table, set it to this angle.

ments to the feed angle as you're resawing. It's much easier to use a straight fence and set it up to compensate for the drift of the blade. Here's how to do it: On a scrap of stock approximately the length of the saw table, mark a line that is parallel to the board's edge. Next, band saw to the layout line and stop at the midpoint of the board and turn off the saw. You will have naturally compensated for the drift as you followed the layout line; now simply set the fence to correspond with the angle of the layout stock. Because most band-saw fences lock parallel to the edge of the table, it's best to

make your own fence (see illustration below). To increase the accuracy of resawing, I construct a tall fence that gives better support to wide stock. A pair of small bar clamps works to secure the fence to the table.

Making the Cut

With the set-up and adjustments complete, making the cut is easy. But first make certain that the face of the stock is free of warp or twist so that it rests firmly against the fence while sawing. It may be necessary to flatten the board with a jointer or plane. The best feed rate for resawing is



With the point fence installed on the resaw fence you can easily saw matching curves, such as this back rail for a chair.

slow and steady. Overfeeding can cause the gullets to fill quickly, causing the blade to stall and shudder. To avoid overfeeding, stay attuned to the sounds and vibrations of your band saw as you make your cut.

When sawing veneer, I smooth the face of the stock after each pass. This provides a smooth surface for gluing the veneer to the substrate. As you reach the end of the stock, use a push stick to complete the cut.

Resawing Curves

Resawing is also a great way to create wide, curved panels, such as parts for chairs. The challenge is to keep the convex and concave surfaces parallel. Here's how I do it: I begin with careful layout of the curve on the edge of the stock. Next, I resaw the curve and follow the line closely. Afterwards I smooth away the band saw marks and irregularities in the contour with a flat-bottomed spokeshave. Set it for a light shaving and cut "downhill" to avoid tearout.

The next step is to resaw the concave curve. To resaw the concave face parallel to the convex face, I equip my band saw with a point fence. The fence is simple:

a stick with a blunt point that is temporarily fastened to my shop-made fence with a couple of screws. To use the fence, I clamp it to the table of the band saw with the point adjacent to the saw teeth. The position is important; the distance from the point to the teeth should equal the final stock thickness plus a slight allowance for cleanup with the spokeshave.

Before you begin sawing, scribe a line on the edge of the stock with a marking gauge that follows the convex curve. To make the cut, position the stock against the point and follow the line of the curve. The point will allow you to easily maneuver the stock while keeping the thickness consistent throughout the cut.

Finally, it's a good idea to use dust collection when resawing. Otherwise you'll be working in a choking cloud of fine dust. If your band saw isn't equipped with a dust port, it's not difficult to rig one up. The most efficient placement of a port is under the table directly below the throat plate. Even so, it's impossible to capture all the dust; I've found that a second port in the lower part of the saw's cabinet greatly increases the effectiveness of the dust collection. **PW**

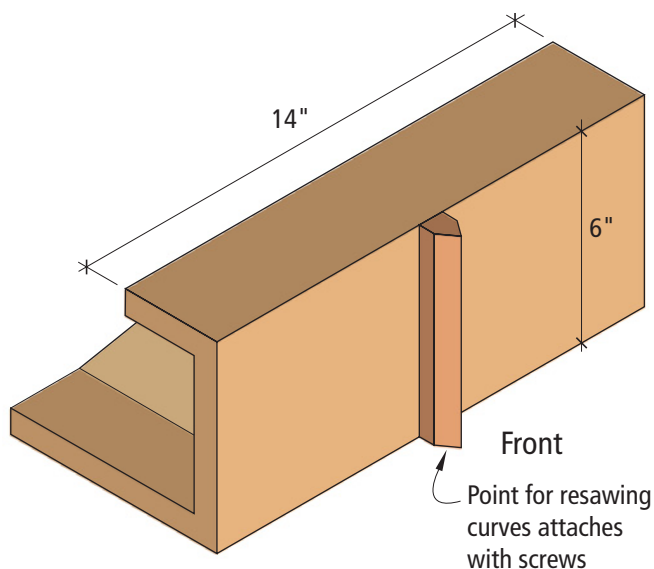

Resaw Fence

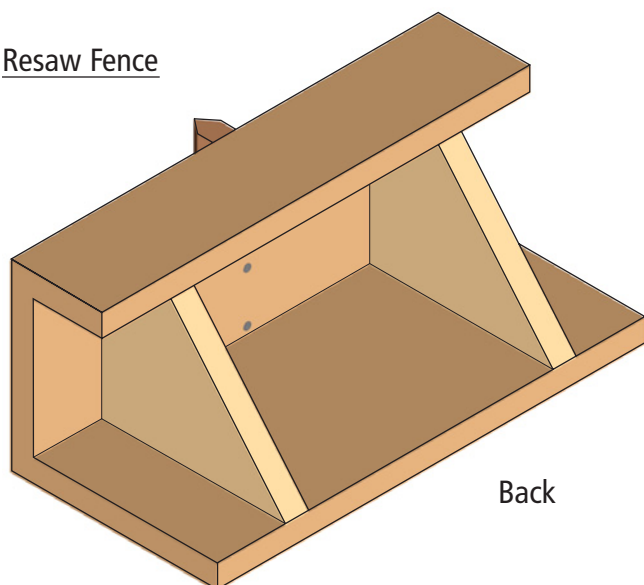



DROP-LID chool Desk

The typical response I get from someone when I tell them I build furniture using only hand tools and traditional woodworking methods is something like, “That must take a long time.”

My typical response to them is that while it may take a little longer, it doesn't take as long as one might think; and besides, I like the process as much as the product. You see, to really enjoy traditional hand tool woodworking, you have to enjoy the work as much as what you build. I may not have built this desk in a weekend, but who cares? I sure enjoyed every weekend that I spent on it.

There are other mindsets that go along with traditional woodworking. This desk illustrates some of those. One thing you have to deal with is the inevitable imperfections of hand-cut joints. You need to accommodate them instead of cursing them. Armed with the right approach, you can build something that looks great and is solid, even if your joints don't stand up to a micrometer test.

Usually, those of us in the hand tool closet have to read the router- and biscuit-based articles and interpret how to build something our own way. This time, the tables are turned. Those of you with the plugs in your hands who want to build this desk should be able to translate what I'm describing into your powered up perspective. Or, you could put down the plug and give this a whirl. I won't tell anybody on you.

As you prepare the stock for each piece in the cut list, be sure and note that some of the parts are cut to finished size as you move along. The dimensions listed are the finished sizes. Some need to be cut larger at first, and those have been noted in the cutting list. For instance, don't cut the tenons on the

side pieces or taper any legs yet, and hold off on cutting the bottom to finished size until the sides and legs are assembled and you can cut it to fit exactly. This is one of the hand tool mindsets: Cut pieces to fit instead of cutting them to pre-defined specifications. Because there are slight variances in hand-made joinery, this allows you to make strong, well-fitted joints that look good, too.

Mortises and Tenons

Once all the parts are cut to their starting sizes, including the extra length on the legs, start by cutting the mortises in the legs and the tenons on the sides, front and back. See the article on how to cut this traditional joint using traditional tools on the following page. The double tenons that go into the back legs receive special attention. Trim the lower tenon of each pair so it's a shade narrower than its mortise. When the back and sides expand and contract with changing humidity, the lower tenons will accommodate the wood movement without splitting. For this to work, you must glue only the top tenon of each pair. The lower tenon still is pegged to hold it in place, but no glue is applied in the joint.

Now dry fit the sides and legs together and see how it looks when it's standing. Chances are that the legs are not all exactly parallel. You can tell this by sight and by measuring the distances between them, one to the next and diagonally. Not to worry, there are parallel legs waiting to be rescued from within those crooked ones by tapering them on all four sides.

For each leg, first measure and mark the center point at the top of the leg on each side that faces out. Then use a plumb line to find the plumb center on the bottom of the

Build this antiqued desk using traditional hand-tool techniques. You'll probably be surprised by how easy it really is.

by Dale Lucas

Using traditional tools and techniques, Dale Lucas recreates 18th and 19th century furniture from his shop, which is located somewhere in times past.



If your legs aren't parallel (a common problem for beginners doing hand work), use a plumb line as described in the story to make things true. At the bottom of the leg, mark the true center. Repeat this process on the other side of the leg that faces out.

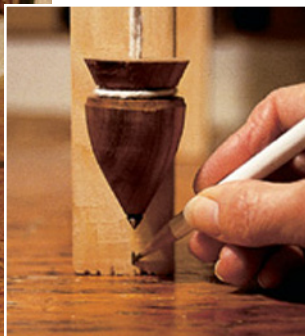

leg on each of those two sides. The bottom of each leg is 1" square, so mark a line that is $\frac{1}{2}$ " out on either side of your two center points. Using a square, carry those lines to the opposite face of the leg. Connect those lines to the point where your taper will begin, which is 1" below the point where the sides, front and back meet the legs. Plane to those lines on all four sides and you will wind up with four parallel legs.

While you have the sides and legs dry fitted together, mark the front legs for final trimming at the top. Mark the leg where the top edge of the side meets it. Using a sliding bevel, transfer that angle of the side to the legs and cut it with a fine-tooth crosscut or back saw.

Raised-panel Bottom

The next step is to fit the floating bottom. This is like a classic drawer bottom that lets humidity have its way without causing breakage. First plow a $\frac{3}{8}$ "-wide x $\frac{1}{4}$ "-deep groove in the sides, front and back pieces to hold the float-

ing bottom. I cut the groove $\frac{3}{8}$ " up from the bottom edge. With the sides and legs dry-assembled, measure the opening and add about $\frac{1}{4}$ " all around to make the bottom fit into the grooves. Now "raise" the edges of the bottom using a hand plane.

Once you have the panel raised, use a hand saw to cut notches in its four corners so the bottom will wrap around the legs. The bottom should fit snugly, but not too tight. This will allow the sides to fit closely to the legs when you assemble the desk.

Turn to the Top Piece

Once you have the small top piece cut and planed to size, plow $\frac{1}{4}$ "-wide x $\frac{3}{16}$ "-deep grooves and dados to hold the three top trim pieces in place. I joined the corners of the trim with dovetails, but then I enjoy the process so the extra work was fun for me. If you want to try your first hand-cut dovetails, these particular ones are pretty forgiving because the stock is thin and the dove-

tails don't show that much when the project is finished.

Normally the decision on where to put the pins and where to put the tails depends on the direction that stresses are applied to the joint. For instance, when the front of a drawer is dovetailed to the sides, the pins are cut in the front and the tails are cut in the sides. That way, glue or no glue, the joint will hold when the front of the drawer is pulled.

In the case of the trim for the top of this desk, there are really no stresses applied, so you can put your pins wherever you like. I happened to put mine on the sides with the tails cut in the back. Once the trim and top are ready for assembly, hold off on gluing them until the end because this is the most fragile part of the desk. Gluing them now risks damage when you assemble the desk.

Spoon Bits to Drill Pocket Holes

The last thing to do before gluing the sides to the legs is to bore the pocket screw holes that will attach the top to the back legs and back piece.

First clamp the sides and back to the legs without the bottom and then clamp the top to the sides where it belongs. Turn the

desk over and now you can bore from underneath, through the back at an angle for the pocket screws. I used a spoon bit in a brace, as it's a champ at boring angled holes. You start it straight into the wood, and then gradually move to the desired angle as you bore. Once the stopped pocket is bored this way, then you use a standard drill bit to bore the screw clearance holes through the pocket and pilot holes into the top piece. A screw in the middle of the back and one up through each back leg should do it.

Assembly

It's time to glue the main box to the legs. First glue and clamp the sides to the legs (don't forget to leave the lower tenons on the back and sides dry to allow for wood movement). Then put the bottom in place without glue and glue the front and back pieces to the side assemblies. Screw the top in place.

The mortise-and-tenon joints in each leg are pegged for strength, and those lower ones aren't going anywhere, with or without glue. A great old way to make these nice and tight is to peg them using a "drawbore tenon" method. It's a great traditional technique, and though we don't have space to cover it here, you can read about



One of my favorite old tools is a Stanley #45 from the early 1900s. This makes quick work and fanciful shavings when plowing the grooves for the floating bottom.

CUTTING MORTISE-AND-TENON JOINTS BY HAND

One of the most common and versatile joints in traditional woodworking is the mortise and tenon. It's been around for a few millennia and has many variations. Here are the basics on how to do it by hand for this particular project. For more on mortises and tenons in general, check out the books listed at the end of this article.

Two Alignment Tricks

As with any joint, layout is important. Mark it right, and you stand a better chance of cutting it right. Tools for this are a marking-mortising gauge and square. Set the mortising gauge to the width of your tenon with the fence of the gauge set to the width of the shoulder. Use it to mark both the tenon and the mortise for the breadboard ends. For the mortises in the legs, adjust the gauge fence so that the mortise is $\frac{3}{8}$ " from the outside of the leg while the breadboard ends are $\frac{3}{16}$ " from the edge. Set the thickness of the mortise to the thickness of the tenon. Use a square to mark off the width of the mortises and tenons.



Because the width of your chisel determines the thickness of your tenon and the size of your mortise, use the chisel to set up your layout tools. Here I'm using my $\frac{3}{8}$ " chisel and my mortising gauge to set up the cuts for my tenons.



To lay out your mortise, use your mortising gauge and the tenon itself to mark the location of the mortise on your stock.

Backsaw the Tenon

Once marked out, use a backsaw to cut the tenon. A simple way to wind up with crisp edges on the shoulders is to use a knife or chisel to cut a small V-groove along the line left by the marking gauge. The scored line left by the gauge forms one side of the groove while you make the other side with the knife. This provides a starting point for the saw just below the surface of the wood, in just the right alignment. Don't bother trimming the tenon until you get the matching mortises chopped out. Then trim either the tenon or the mortise as needed until they fit.



To make clean tenon shoulders, cut a V-groove along the cutting gauge line. Start your backsaw in this groove and your shoulders will have a clean edge. Cut the tenon with a small back saw or dovetail saw.



Cut just shy of the waste side of the line. Then chamfer the edges of the tenon using a chisel, which will make assembly easier.

Chop the Mortise

The most important thing is to make the mortise perpendicular to the face of the stock. Failure on this point is the root of all sorts of joint evil. Unless you have an eye for this type of alignment, check your chopping angle periodically with a square set next to your work piece.

If you're new to chopping mortises by hand, then think of this as chipping more than chopping. Take out the wood that fills your mortise-to-be one layer of chips at a time. Make the chips by making a series of chisel cuts from one end of the mortise to the other. Then carefully remove the chips with the chisel. Repeat the chip making and chip removing until you are at the desired depth. One tip for making clean finished ends of the mortise; do your chopping about an $\frac{1}{8}$ " in from the ends until the final depth is achieved. Then you can clean those ends up easily.



Chop a series of cuts across the mortise from end to end, then clean out the loose chips. Repeat this until you reach the desired depth.



When chopping a mortise, pause once in a while to check your direction with a square.



Before raising your bottom panel's cross grain, chisel down the corners so you won't split the off the edge as you plane.



Use a smoothing plane or jack plane to bevel the underside of the bottom panel.

it in Jeffrey P. Greene's "American Furniture of the 18th Century" (The Taunton Press).

The other option is to clamp everything tight during glue up and simply bore the holes for the pegs. Bore into the legs from the outside, centered on each tenon and bore just a little past the tenon. Drive home riven hardwood pegs just far enough to go through the tenon and fill the hole. Later you can trim these flush. I typically use oak for the pegs, but whatever is on hand will do as long as it's hard and straight-grained.

I like to first split these pegs out square, just a little bigger than the hole. Taper one end of the peg with a chisel, gouge or knife to make it easy to start into the hole. Leave the square back end a little bigger than the hole so when you drive it home, it will bite into the wood surrounding the hole. Don't make it too big, and don't drive them in too hard, or you'll split your hard-earned legs. When all your joints are pegged, remove the clamps and trim the pegs flush. I do this with a broad sweep gouge.

Breadboard-end Lid

The next big step is to make the lid with its breadboard ends. The mortise-and-tenon joints are made pretty much the same way as the ones in the legs and sides with some slight differences. The breadboard ends stabilize the lid, but they need to allow for movement in the tenons as the lid shrinks and grows with the seasons.

To do this, make two of the three tenons a little narrower than their corresponding mortises. Leave the one closest to the top full size and use glue in this mortise only, as this will anchor the lid so you maintain a constant gap all the way across where the top and lid meet.

Another part of this "freedom of movement act" is to enlarge

the peg holes in the floating tenons in the direction of the float.

Once you have the breadboard ends fitting well on the tenons, remove them and bevel the upper edge so it fits against the top. The simplest way to lay this out is to set a sliding bevel on the top edge of one side and set its blade to the front edge of the secured top. Transfer that angle to each end of your lid (without the breadboards in place). Connect the angled ends with lines across the underside of the lid and use a jack plane to take the edge of the lid down to those lines.

You should wind up with a good match between the lid and the top. When the lid is angled right, put the breadboard ends back on, mark them to match the edges of the lid and trim the ends

to length. When you assemble the lid, glue the full-sized anchor tenons but leave the others dry. Pegging all six tenons will hold everything securely.

Details

Now that we're getting fewer and smaller shavings, we must be nearly done. The last few steps include marking and mortising the hinges, rounding the edges of the lid, and gluing the trim on the top. I painted the outside of my desk with old-fashioned black enamel paint and the inside with a light contrasting color. As soon as I was done painting the outside, I used steel wool with some mineral spirits and rubbed a few edges and high spots to give some character to my new, old antique. I wiped the excess off and let that dry.

After a day or so, I wiped it with a concoction that leaves it with a faint aged brown tint made using: 2 oz. burnt umber artist's oil paint, 2 oz. burnt sienna artist's oil paint, 8 oz. turpentine, 3 oz. boiled linseed oil and 1/4 oz. japan drier.

After that dried for a couple of days, I added a light coat of wax and sat down to enjoy the final product. Hey, while I enjoy the process more than the product, I still like the product pretty well, too! **PW**

HELPFUL HAND TOOL BOOKS

"The Complete Woodworker," edited by Bernard E. Jones. This is a reprint of an old classic. 10 Speed Press, copyright 1980. ISBN 0-89815-022-1.

"Hand Tools, Their Ways and Workings" by Aldren A. Watson. Lyons & Burford. Published in 1982 by Norton. Copyright 1982 by Aldren A. Watson. ISBN 1-55821-224-8.

"Bench Work in Wood" by W. F. M. Goss. I don't have a copyright or ISBN number but the inside leaf says "Boston, USA, Published by Ginn & Company, 1901." Mine is a reprint that I got from Mid-West Tool Collectors Assn. Inc., www.mwtca.org

DROP-LID SCHOOL DESK

NO.	ITEM	DIMENSIONS (INCHES)			NOTES
		T	W	L	
2	Front legs*	2	2	29 1/8	
2	Back legs	2	2	33 1/4	
1	Back	3/4	6 3/4	22 1/2	1" TBE
2	Sides	3/4	6 3/4	16 1/2	1" TBE
1	Front	3/4	2	22 1/2	1" TBE
1	Bottom*	3/4	17	23	
1	Top	3/4	4 1/8	25 1/4	
1	Lid	3/4	16 1/4	24 1/4	1" TBE
2	Breadboard ends*	3/4	1 1/2	16 1/4	
1	Back trim for top	1/4	2 3/16	24 1/8	
2	Side trim for top	1/4	2 3/16	3 3/4	
18	Pegs for tenons	1/4	1/4	1 1/4	

TBE=tenons both ends; *Finished dimension; cut longer initially

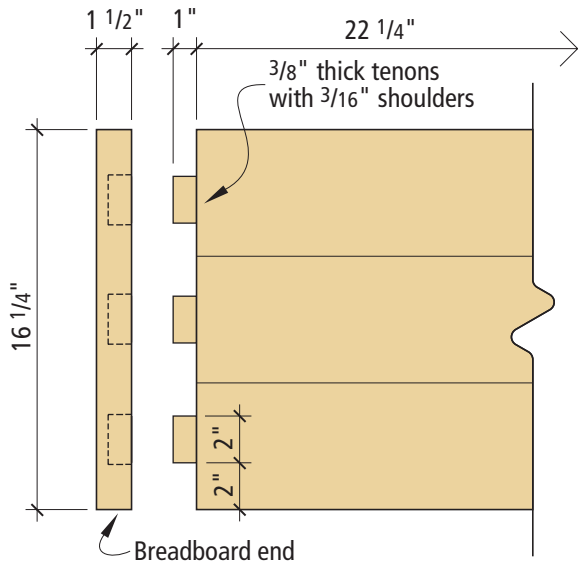

Breadboard-end lid

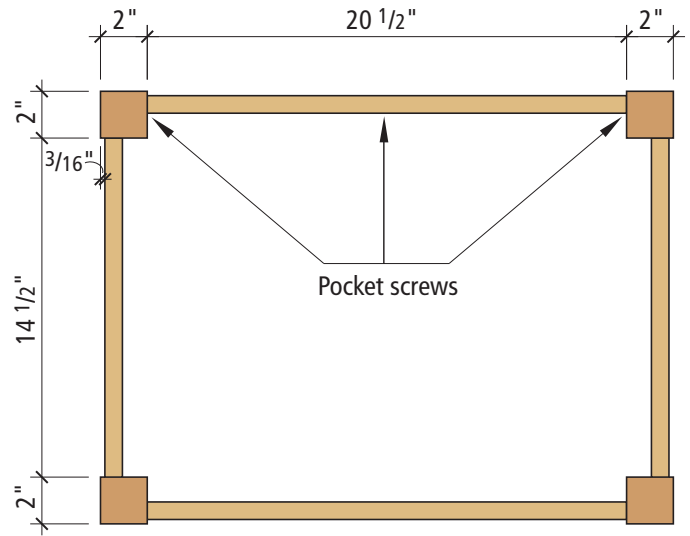

Plan-lid

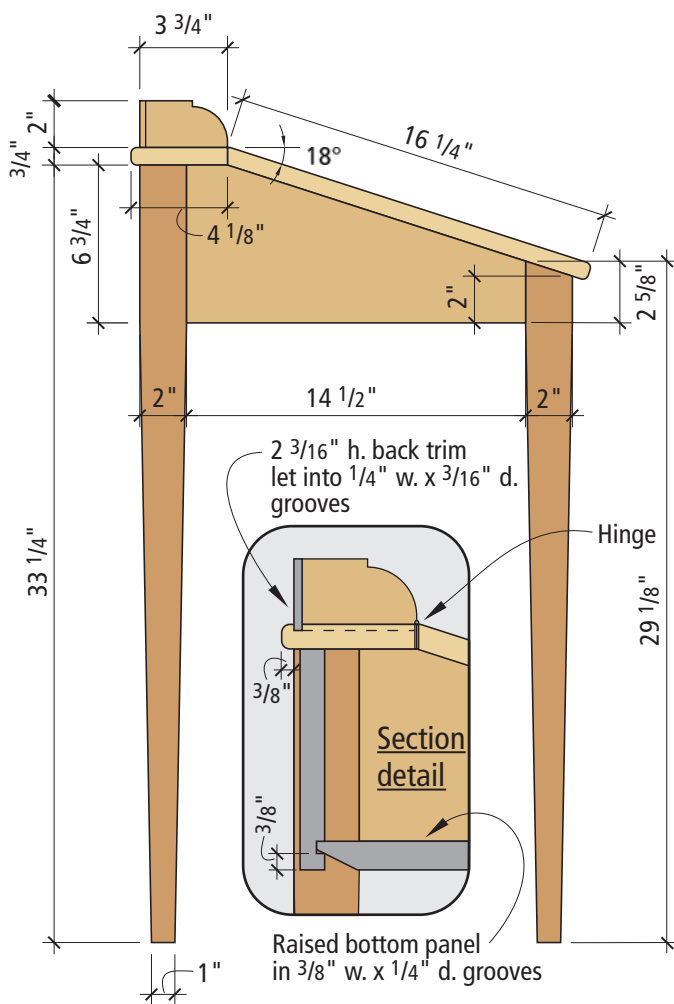

Profile

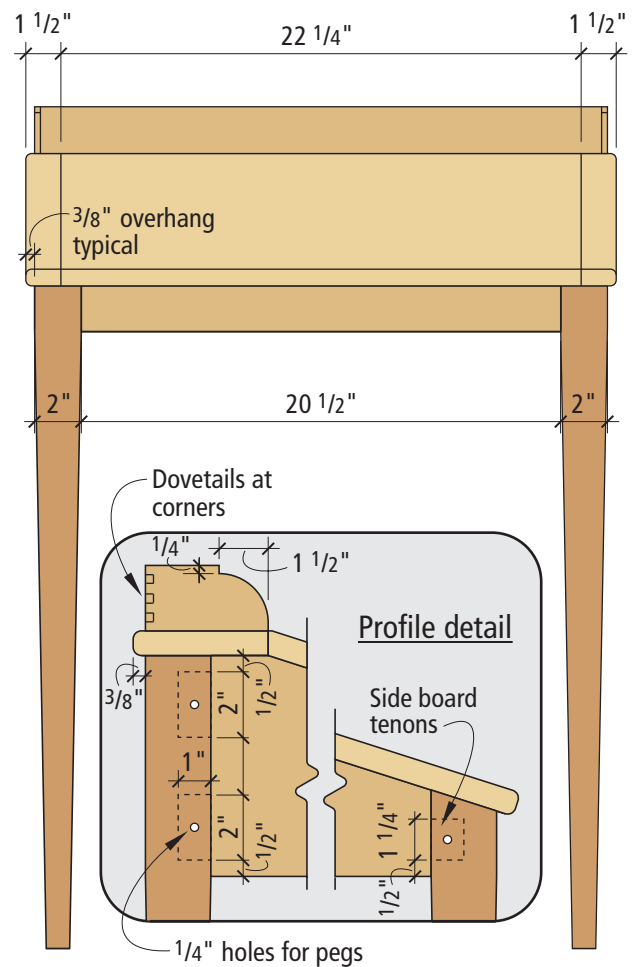

Elevation



Achieving the dark reddish-brown finish favored by Gustav Stickley has long been a goal of mine. My reproduction of a No. 332 Morris chair uses the finishing methods outlined in this article. The finish I matched it to is on the antique slipper rocker at right. They match quite well, though lighting differences in the photos make the slipper rocker look lighter in color.

Arts & Crafts Finish



For several years I've experimented with ways to get the look of ammonia-fumed oak without the danger. Here's exactly how to do it.

The best Arts & Crafts antique I own is a small rocking chair that few visitors to my house ever notice. Made by Gustav Stickley's furniture company, the rocker has all the hallmarks of a classic period piece: through-tenons, pegged joints and the original rush seat. But that's not why I like the chair.

I get lost in the finish. The ray flake of the quartersawn oak burns red, but the piece as a whole is a dark chocolate brown. For several years I've tried to replicate that look without resorting to fuming the oak with ammonia – a difficult process in its own right. Aqueous ammonia is dangerous to handle, and even Stickley acknowledged that he had to stain some areas of his fumed pieces to even out the color.

After trying lots of products on the market, I think I'm really close. This is a fairly simple process,

though you do have to wait a couple days for things to dry between each step. However, I assure you it's worth the time.

The Secret: Dye Plus Glaze

In a nutshell, you dye the oak red and then put a brown stain over it. The trick is choosing the right ingredients and applying them correctly. Check the supplies box to order all the coloring products you need for this finish.

Sadly, I have to start you off by talking about sanding. No matter how you prepare your wood for finishing (power sanding, planing or scraping), you need to pay close attention to the ray flake of the oak before you start finishing. Random-orbit sanders leave little "pig tails" in the ray flake

that will collect pigment, as will marks from a smoothing plane. In the end, these will detract from your hard work.

So once you have the surface sanded to its final grit (I usually go to 180 grit), get out your sanding block and 220-grit sandpaper. Hand sand the parts of your project, being careful to sand with the grain. It doesn't take much effort, just five or six strokes over an area. Now remove as much of the sanding dust as possible using a tack cloth or compressed air.

Mix the Dye

About four years ago, we were turned on to J.E. Moser's aniline dyes, and we're hooked. Moser sells three different kinds of dyes, and each dissolves in a different

medium: water, alcohol or an oil-based carrier such as lacquer thinner or toluol.

We've experimented with the alcohol-based dyes (they dry extremely fast, which speeds things along), but I'm married to the water-based products because they are much more fade-resistant than the other two types of dye.

The downside to the water-based dyes is that they raise the grain. To combat this problem, I wipe the entire project down with a clean wet rag before the final hand sanding with 220-grit sandpaper. The sandpaper knocks down the nibs raised by the wet rag. Then, when you apply the water-based dye, the grain won't get nearly as fuzzy.

The directions on the dye say to mix 1 ounce of powder with 1 quart of nearly boiling water. I've found this is too strong a color. Try mixing ½ ounce of powder

by Christopher Schwarz

Comments or questions? Contact Chris at 513-531-2690 ext. 407 or chris.schwarz@fwpubs.com.



Water-based finishing products raise the grain when applied. To combat this, raise the grain before your final sanding by wiping down the project with a wet rag. The final sanding will cut down the raised grain and nearly eliminate any raised grain when you dye the project.



Apply the aniline dye liberally with a disposable paint brush, then wipe off the excess with a clean rag. When the dye has dried, it should look this shade of orange. Continue cutting your dye with water until you get something in the ballpark.

with a quart of water. Let the solution cool overnight. Apply it to a test board and compare it to the photograph above. If it's still too strong, add more water until the color is very close.

Apply the Dye

You need a way to apply the dye (a sponge, rag or disposable paint brush) and a clean rag to remove the excess. Load the brush, rag or sponge with the dye and flood one surface of the project, such as the arm or the top or a leg. If you are stingy with the dye, it might not wick into the grain. Immediately wipe off the excess with your rag.

Dye the remaining parts of the project. If you get overlap marks where you went over a surface a few times, don't get worked up. Let the dye dry overnight – things will look better in the morning. Then, rest assured because the next processes will hide most of your problems.

Using Glaze as a Stain

In my opinion, the real secret weapon in this process is the next step: adding the glaze. Glaze is a product often used by professional painters and finishers to color

wood in a wide variety of ways. Glaze usually is applied over a sealed surface and not on raw wood. That is, it's added over a sealer coat and then topcoated again.

Used this way, glaze can "antique" a project by adding years of wear and grime to the recesses in a raised-panel door or it can bring out the detail in a carving.

This, however, is not how I use this product. I use it like a thick-bodied stain.

The hardest part of using this glaze seems to be purchasing it. About five years ago it was made by a company called Guardsman. Then a company called Lilly bought it. Now my friends at the paint store say that Valspar manufactures the product.

I've never seen this brand of glaze for sale in the major woodworking catalogs; we've always bought ours from a local professional paint store (Cincinnati Color). Recently, I've discovered that you can buy it from woodfinishing.com in both gallon and quart sizes. Check the supplies box for information.

Once you get your hands on the glaze, you must mix it thoroughly before use. In general, stir-

ring it with a paint stick will just wear out your arm. The solids in this stuff are tough.

I mix glaze using a device for stirring paint that you chuck into your electric drill. Chuck the paint stirrer into your drill press and raise the table so the stirrer is just above (but not touching) the bottom of the can of glaze.



You need to mix the glaze thoroughly before using it. Chuck a paint stirrer into your drill press and make a splatter guard like the one shown here. Set your drill press to its lowest speed setting.

Set your drill press to its lowest speed setting. Let me repeat that: Use your lowest setting. We're still cleaning up dried glaze in our shop from an embarrassing accident I had more than three years ago. Clamp a shop-made spatter shield on top of the can (see the photo at left for what this looks like) and mix the glaze for a couple hours. You'll know that the glaze is thoroughly mixed when no solids are resting at the bottom of the can.



Here's how you should ball up your cheesecloths when applying and removing glaze.



Apply the glaze liberally with your cheesecloth. Once it's applied, allow it to flash before removing it.

It doesn't take a lot of effort to remove the excess glaze. Wipe the board until you get an even tone.

When the glaze is mixed, prepare two cheesecloths (available in the paint section of any home center). One applies the glaze, the other removes the excess.

Fold the cheesecloths so they fit in your hand and there are no edges or seams where you are applying or wiping off the glaze.

Buy some heavy-duty gloves – I prefer the thick orange ones you can buy at home center stores. Glaze is difficult to remove from your skin and you really shouldn't be dipping your hands in it.

Dip your first cheesecloth in the glaze and apply it liberally to a surface of your project. The stuff is practically opaque, so your project should look almost black. Now start working on the next big surface while you let the first area dry a bit. You want the glaze to "flash," which is when the wet sheen of the glaze starts to turn dull. It usually takes about 10 or 15 minutes, depending on the temperature and humidity.

Once your glaze flashes, take your second cheesecloth and begin removing the excess glaze. Wipe gently (but not gingerly) and you'll see the true color of your project appear. The ray flake will look



After you apply your topcoat, the reds in the oak's ray flake will pop out of the brown background.

red, the grain lines will be brown. After a few minutes, the glaze will start to set up and the overall color will look very dull. Don't be concerned, the topcoat will bring out all the color again.

Repeat this process until you're done staining the entire project. When you're done, it's a good idea to examine your project closely for drips, runs or overlap marks. These are easily remedied because glaze is reversible. Just get out your cheesecloth that was used to apply the glaze and go over it again. Keep messing with it until it looks right.

Allow the glaze to dry overnight. Even after 24 hours, you still can manipulate the glaze a bit. Before you add a sealer coat to your project, get a clean cheesecloth and look again for any areas that appear muddy or have runs. By rubbing lightly with a cheesecloth you still can fix things.

Topcoat Protects the Glaze

Hands down, your best option is to spray on lacquer or shellac. If you don't have a spray system and the project is small, use spray lacquer in aerosol cans. You can buy it at home center stores. Look for a product that states it dries in 30 minutes – most likely it's lacquer.

If your project is large and you don't have a spray system, use the aerosol lacquer to spray a sealer coat of lacquer on the project to lock in the glaze. Then topcoat that with a brushed-on finish you're comfortable with.

I don't recommend applying the sealer coat over the glaze with a rag, and don't use an oil finish. You need a film finish to protect the glaze. And though I've never ragged on a sealer coat over glaze, several people who have tried this method say that the rubbing action wipes the glaze around and makes a true mess of things.

After your first sealer coat, sand between coats and add as many coats as you usually do to a project. When I spray lacquer, I usually use three thin coats. **PW**

SUPPLIES

Woodworker's Supply
800-645-9292
www.woodworker.com

J.E. Moser's Golden Amber
Maple water-based aniline dye.
• 1 oz., item #W14901, \$4.85
• 4 oz., item #W14904, \$12
• 8 oz., item #W14908, \$20.50

Woodfinishingsupplies.com
507-280-6515
www.woodfinishingsupplies.com

Lilly Professional Glaze, choose the color "warm brown"
• quart, item #WL6100-25, \$9.95
• gallon, item #WL6100-1, \$31.59

CLASSIFIEDS

ALARMS

WIRELESS DRIVEWAY ALARMS
 Lets you know anytime anyone walks or drives into your place.



DAKOTA ALERT, INC.
 BOX 130, ELK POINT, SD 57025
 605-356-2772
www.dakotaalert.com

Reader Service #130

PLANS & KITS

BARGAIN BOOKS FOR WOODCRAFTERS
 Over 800 books on woodworking and other hobbies, most \$2.95 to \$6.00! Build birdhouses, whirligigs, furniture, more.

FREE CRAFTS CATALOG—write to
 Dover Publications, Dept. PW0205
 31 E. 2nd St., Mineola, NY 11501.

Reader Service #134

WOODTURNING SUPPLIES

Get a **Free Copy** of our
CATALOG for WOODTURNERS
 Call Toll Free... **1-800-683-8876**
 or write...
Packard Woodworks PO Box 718 Tryon, NC 28782
 website: www.packardwoodworks.com



"The Woodturners' Source"

Reader Service #139

BAND SAW BLADES

Band Saw Blades
 Swedish Silicon Steel
Timber Wolf™
 1/8" Through 2"



call: Suffolk Machinery
 800-234-7297 Free Catalog
www.suffolkmachinery.com

Reader Service #131

ROUTER BITS

"Forrest" Saw Blades
 10" Woodworker II - \$97
 10" Chopmaster - \$109
 12" Chopmaster - \$123
 8" Dado King - \$227

Free Shipping on Saw Blades

www.librawood.com

Reader Service #135

BUILDINGS

HUGE SAVINGS ON REMAINING INVENTORY OF QUALITY STEEL BUILDINGS!



SAVE THOUSANDS ON SELECT SIZES
 20x30 • 25x34
 30x54 • 50x150
 Additional sizes available
 Made in the U.S.A.

WORKSPACE FOR WOODWORKING TOOLS & EQUIPMENT STORAGE

U.S. Buildings.
www.us-buildings.com

Call Now! **1-800-463-6062**
FREE BROCHURE & FACTORY PRICE LIST

Reader Service #132

www.routerbits.com

Whiteside Router Bits
 Systematic Saw Blades
 Fisch Forstner Bits
 HTC Mobile Bases



Router Bits on the Web

Reader Service #136

BOOKS & CATALOGS

WE HAVE A WIDE VARIETY of woodworking books—from small projects, to home improvement, to enhancing your woodworking skills, and more! To see our full line of books, please visit our Website at www.popularwoodworking.com/store/books/

FINISHES

SPRAY-ON SUEDE. Line boxes easily. Free brochure with sample. DonJer, 13142 Murphy Road, Winnebago, IL 61088; 800-336-6537; www.donjer.com

HARDWARE

HARDWARE FOR CABINETS, closets, furniture etc. Free catalogs: www.bainbridgemfg.com; www.hannahshandles.com; call 800-255-4702.

FURNITURE, HOOSIERS, AND TRUNK HARDWARE. Extensive selection. Catalogue \$3.50. Centralia Trunk Company, 1541 Chestnut St., Wisconsin Rapids, WI 54494.

EASY ORDERING! ONLINE CATALOGUES: hardware, KD & other fasteners, sanding discs, belts, lots more. Profhdwr.com & sandingproducts.com

MISCELLANEOUS

POST OFFICE BOX DOOR FRONTS, #1 \$8.00; #2 \$9.00; #3 \$10.00 + S&H. Coin slot plates, etc to make banks. SASE for info. Hubbert, PO Box 1415, Fletcher, NC 28732; 828-687-0350.

PLANS & KITS

BAR PLANS - Great looking bar for your office or residence. Traditional, L-shaped, or portable. www.precision-images.com.

QUALITY WOODWORKING PLANS and patterns since 1977. Adirondack, swings, toys, bird houses, and more! www.plan-craft.com.

CARLYLE LYNCH MEASURED DRAWINGS- Museum and private collection furniture plans by Carlyle Lynch. Catalog \$2. PO Box 13007, Arlington, TX 76094; 817-861-1619.

PLANS FOR RE-SAWING BANDSAW. Cuts 12" thick. \$15.00. Doverton, 2742 Hickman Road, Des Moines, IA 50310.

TOOLS

LASER GUIDE for chop saws, drill presses, radial arm saws etc. \$29.95. Free brochure: 800-456-4987.

35' x 45' x 10'
\$4,198

We Ship Anywhere In The USA!!! 10,000 Sizes. Bolt-Together All Steel Buildings & Homes. Call Today For A Price Quote And Brochure.

HERITAGE BUILDING SYSTEMS®
 800.643.5555
heritagebuildings.com

BUSINESS OPPORTUNITIES

Bunk Beds



Clear \$300/day building wood bunk beds at home. Start out in spare time & expand the business at your own pace. Earn \$185 on a \$269 sale, \$411 on a \$611 sale. Call 800-382-3180 Ext 1603. Bunks, Dept. 1603, Box 2000, Avon, MN 56310

Reader Service #133

SAWMILLS

A ONE MAN PORTABLE SAWMILL that you can afford.

The Baker Model 18M Band Sawmill.

Cuts a 30" dia. log! Up to 24-HP gasoline engine!

BAKER Products
 Canadian number: (705) 835-3222
www.baker-online.com

CALL: **(573) 663-3133**

Reader Service #137

WOOD EPOXIES

QuikWood® Epoxy Adhesive Putty Stick
 repair rebuild restore bond attach patch seal

Easy to Use - No Mess



Solvent Free
 VOC Free

Shapes like modeling clay. Can be sculpted for fine detail. Bonds permanently. Hardens like wood. Sand, carve, drill, tint, paint, and finish

1. Cut 2. Mix 3. Fix

"When Fillers or Glue Won't Do"

888 4 FIX WOOD ext. 2209 - www.epoxysticks.com

Reader Service #138

www.popularwoodworking.com

Looking for on-target, online
woodworking information?
Look no further than

popularwoodworking.com

You'll find:

- tool reviews •
- project plans •
- woodworking books •
- **Popular Woodworking back issues** •
- subscription information •
- free e-newsletter •
- **Popular Woodworking article index** •
- customer service contact info •
- and more! •

Stop in today and say hello!

(we mean it...you can email the editors!)

CLASSIFIED ADVERTISING ORDER

Send to: **Popular Woodworking®**

Attn: Joan Wright
1507 Dana Avenue
Cincinnati, Ohio 45207
Phone: (800) 388-1820
Fax: (513) 531-1843

(PLEASE PRINT OR TYPE)

Your Name _____
Company (name in ad) _____
Address _____
City _____
State _____
Zip _____
Phone _____
Fax _____
Payment: Check enclosed
 Bill my Visa/MasterCard
Card _____
Number _____
Exp. date _____
Signature _____

CLASSIFIED DISPLAY

1X 3X 6X

1-inch @ \$260 \$230 \$210
2-inch @ \$520 \$460 \$420

• Discounts for consecutive advertising.

READING NOTICES:

15 word minimum. • Save 15% with 3 issues.

15 Words (minimum).....\$63.00

Each additional word

@\$4.20.....\$ _____

Total for 1 ad.....\$ _____

15% Discount with 3

Consecutive Issues:

Total of one ad.....\$ _____

Minus 15% (or x .85).....\$ _____

Total for 3 ads.....\$ _____

AD COPY:

(Please print. Use separate sheet of paper for additional words)

READER SERVICE PAGE #

Adams Wood	100	17
American Clamping	141	17
Arrow	101	12
Baker Products	137	72
Bunk Beds	133	72
Clayton	102	12
Craftsman	119	10-11
Dakota Alert	130	72
Datco	103	17
Delta	104	5
DIY Channel	-	74-75
Dover Publications	134	72
Fein Power Tools	105	Cvr 3
Forrest Mfg.	126	51
Franklin Int'l	106	2
Gorilla Glue	113	18
Grizzly Imports	107	Cvr 2
Grizzly Imports	108	1
Grizzly Imports	109	13
Heritage Building Systems	-	72
HTC Products	110	25
Join Tech	111	21
Lee Valley	-	19
Leigh Industries	-	15,19
Librawood	135	72
Lie Nielsen	112	24
Makita	129	Cvr 4
McFeely's	114	15
MLCS	115	9
Niagara Lumber	126	17
Nyle	116	21
Osborne	117	15
Packard Woodworks	139	72
Polymeric Systems	138	72
Price Cutter	118	21
Routerbits.com	136	72
Smithy	120	19
Suffolk Machinery	131	72
US Buildings	132	72
West Penn	-	8
Whitechapel	121	8
Wood Wizard	128	19
Woodcraft Supply	-	21
Woodcraft Supply	123	24
Woodline Arizona	124	16
Woodmaster Tools	-	8
Woodmizer	-	25
Woodstock International	125	7

The Case for Shellac

Long neglected by woodworkers in favor of oil and varnish finishes, this gift from the insect world is a great finish for home woodworkers. Here's why.

Today, shellac is the most under-appreciated of all finishes, but this hasn't always been the case. Until the 1920s, when lacquer was introduced, shellac was the primary finish used in furniture factories and small woodworking shops. It continued to be the favored finish of professionals finishing interior wood trim and floors, and of hobbyists finishing everything, including furniture, until the 1950s and 60s.

Then polyurethane and "wiping" varnish (varnish thinned about half with paint thinner and often mislabeled "tung oil") were introduced and widely promoted. Beginning in the 1970s, blends of linseed oil and varnish, like Watco Danish Oil, were promoted in magazines for their ease of use.

Instead of defending shellac during this period, suppliers retreated to the position that shellac was a good sealer for stains and knots. They also allowed shellac to get an exaggerated reputation for weak water resistance, and they increased its stated "shelf life" from one year to three years. (Shellac slowly deteriorates after it's dissolved in alcohol. After about a year it no longer hardens well enough or is water-resistant enough to be used as a complete finish on most furniture and cabinet surfaces. Always use shellac within a year of when it was dissolved.)

Now shellac is rarely used as a finish except by high-end antique refinishers (which ought to tell you something). This is terribly unfortunate, because shellac still is one of the best finish choices for most woodworking and refinishing projects.

What is Shellac?

Shellac is a natural resin secreted by insects called lac bugs, which attach themselves to certain trees native to India and Southeast Asia. Suppliers buy the resin and sell it as flakes, or dissolve it in alcohol and package the solution in cans for you to purchase.

Natural shellac is orange (amber) in color and is your best choice when you want to



Photos by Al Parrish.

Shellac is preferred by high-end refinishers and is a good finish for home woodworkers because it dries quickly, builds well and is easily reversed if disaster strikes.

add warmth to wood. Most old furniture and woodwork was finished with orange shellac. Bleached shellac (sold as "white" or "clear") is best when you want to maintain the white-

ness of a pickling stain or the natural color of light woods such as maple, birch and poplar. You can mix orange and bleached shellac to achieve an in-between color.

SHELLAC PROS AND CONS

Advantages:

- Much more water- and scratch-resistant than oil or oil/varnish-blends, which cure too soft to be built up on wood.
- Better dust-free results than varnish or polyurethane, which cure very slowly.
- Less polluting, less of a health hazard and less smelly than varnish, polyurethane or lacquer.
- Easier to apply and richer-looking than water-based finishes.
- Easier to clean (with ammonia and water) than all other finishes.

Disadvantages:

- Not water- or scratch-resistant enough for surfaces such as kitchen cabinets and tables that take a beating.
- Available only in gloss sheen.
- Tends to ridge at the edges of brush strokes.
- Slowly deteriorates after being dissolved in alcohol.

Natural shellac contains about 5 percent wax and will produce excellent results; but dewaxed shellac, whether pre-dissolved or in flake form, is more water-resistant. You can remove wax from regular shellac by letting it settle and then decanting the liquid.

Shellac is a very old finish, so it has an old measuring system based on the concept of “pound cut.” One pound of shellac flakes dissolved in one gallon of alcohol equals a one-pound cut. Two pounds in one gallon is a two-pound cut; one pound in a quart is a four-pound cut; and so on.

The shellac you buy at the paint store is almost always a three-pound cut, which is very thick for brushing or spraying. Thin this shellac by half with denatured alcohol (shellac thinner) and make adjustments from there to reach the thickness, or pound cut, you feel most comfortable working with.

To obtain maximum freshness and thus maximum hardness and water resistance, use denatured alcohol to dissolve your own shellac from flakes, which are available from many woodworking suppliers. Start with a two-pound cut, and adjust from there.

Applying Shellac

To brush shellac, remember that alcohol evaporates rapidly, so you must work fast. Use a good quality natural- or synthetic-bristle brush, or a foam brush, and brush in long strokes in the direction of the grain if at all possible. Work fast enough on your project to keep a “wet edge,” and wait until the next coat to fill in any missed places if the shellac becomes tacky.

Spraying shellac is no different than spraying other finishes. Just as thinning shellac reduces brush marks during brushing, thinning reduces orange peel while spraying.

However you apply the shellac, allow the first coat to dry about two hours, then sand with gray, 320-grit stearated (self-lubricated) sandpaper just enough to remove dust nibs and raised grain. Use a light touch to reduce sandpaper clogging and to avoid sanding through the finish.

Remove the dust and apply a second coat. Add more alcohol to the shellac if you're getting severe brush marks or orange peel, or if air bubbles are drying in the film. The alcohol will slow the drying and allow the bubbles to pop out. There is no limit to the amount

you can thin shellac, but you may have to apply more coats to get the build you want.

Apply as many coats as necessary to achieve the look you want. Each new coat dissolves into the existing coat, so there's no need to sand between coats except to remove dust nibs or other flaws. To see flaws like runs and sags before they dry in the film, arrange your work so you can see a reflected light in the area you're finishing. Then brush out the flaws before they dry.

If the humidity is high, or if there's too much water in the alcohol you've used to thin your shellac, it may turn milky-white. This is called “blushing” and is caused by moisture settling in the finish. Wait for a drier day, use a purer alcohol or both. You usually can remove existing blushing in the finish by applying alcohol on a dry day or by rubbing with an abrasive, such as a Scotch-Brite pad or steel wool.

If, at any time, you create problems you can't remove without creating greater problems, strip the finish with alcohol or paint stripper and begin again. In between coats you can store your brush by hanging it in a jar of alcohol, or you can clean it easily by washing it in a half-and-half mixture of household ammonia and water. You can reclaim brushes with hardened shellac by soaking in either solution.

When you have applied the desired number of coats (three is minimum in most cases), you can leave the finish as is. Or you can level it using 320-grit and finer sandpaper and a

To ensure maximum hardness and water resistance, make your own shellac by dissolving shellac flakes in denatured alcohol. The brown container in the middle is a light-proof collapsible container (usually used for photographic chemicals) that's great for storing shellac.



flat backing block, then rub it to the sheen you want using Scotch-Brite pads, fine steel wool or abrasive compounds like pumice and rottenstone. If the rubbed finish shows finger marks easily, apply paste wax or an oily furniture polish. **PW**

Bob Flexner is author of “Understanding Wood Finishing” and a contributing editor to Popular Woodworking.

PAST TOOL REVIEWS

During the course of the year we run numerous tool reviews and tool tests. We also field many phone calls from readers who missed the issue with the review of the tool they're looking to buy right now. To provide you with the best information to help you make your next purchasing decision, we've gathered brief information and comments about the tools covered during the past year. Many of these full articles are available in back issues that can be purchased at www.popularwoodworking.com.

February 2001, Issue #120

Fein RT-1800 Plunge Router

Performance: 5, Value: 4

"The excellent performance of this router...makes the money well spent for any commercial application, as well as for the demanding home woodworker."

Delta 40-680 20" Scroll Saw

Performance: 4, Value: 3

"...(W)e found this to be a smooth, powerful and easy-to-use saw. It has the feel of a stationary machine rather than a benchtop model and performed very well."

Grizzly G9900 Dial Protractor

Performance: 5, Value: 4

"If you work with angles in your shop (and who doesn't) this protractor will save you hours of swearing and prevent lots of mistakes."

Rockler's Sur-Loc Miter Gauge

Performance: 3½, Value: 4

"Though the Sur-Loc is more accurate (than standard miter gauges), you'll want the adjustability of your old miter gauge when cutting compound miters...needing angles in ½° increments."

Advantage Quick Grip Clamps

Performance: 4, Value: 3

"The Advantage clamps merge a one-handed clamp design with an F-style threaded screw design, resulting in an easy-to-use clamp with good holding power."

Hitachi FDS 12VA Drill/Driver Kit

Performance: 3½, Value: 5

"...(O)ne of the lowest priced 12-volt cordless drills out there...features all over the place...."

Fein's Multimaster Sander

Passed the Endurance Test.

Review of Combination Squares

Editor's Choice to: Starrett C434-12-R.

Review of Low-angle Block Planes

Editor's Choice to: Lie-Nielsen 60½.

Best Buy to: Veritas 05P22.01.

Review of Bevel-edge Chisels

Editor's Choice to: Ashley Isles, E.C.E., Marples Blue Chip and Two Cherries/Hirsch.

Best Buy to: Craftsman, Marples Blue Chip, Stanley and Woodworker's Supply.

April 2001, Issue #121

Bench Dog RT100 Router Table

Passed Endurance Test.

Bridgewood TSC-10CL Contractor Saw

Performance: 4, Value: 5

"...I rate the TSC-10CL as a great saw for the price...this saw isn't missing much."

Vaughan Mini-bear Pull Saw

Performance: 4, Value: 4

"...(O)ne of the least expensive...on the market."

Woodcraft Drill Sargent Hold Down

Performance: 4, Value: 3

"While I found this fixture a great addition to the drill press, the \$90 price tag made me think twice about its value."

Review of Portable Planers

Editor's Choice to: DeWalt DW733 and Ridgid TP1300.

Best Buy to: Delta 22-560.

June 2001, Issue #122

Powermatic 719A Mortiser

Performance: 4, Value: 4

"...(A) machine that is everything a home woodworker could ever need, and an inexpensive alternative for the professional shop."

Lee Valley Folding Dozuki Saw

Performance: 4, Value: 4

"For the luxury of having a fine-cutting Dozuki handy at all times, this is a great buy."

Clifton Bench Planes

Performance: 5, Value: 4

"Yes, you need one. Yes, you can afford it...it's worth every bit of the \$200."

Hitachi FDS10DVA Cordless Drill Kit

Passed the Endurance Test.

Review of Biscuit Joiners

Editor's Choice to: Porter-Cable 557 Type 2.

Best Buy to: Freud JS102 and Makita 3901.

August 2001, Issue #123

Veritas #4½ Smoothing Plane

Performance: 3½, Value: 4

"Once fettled, it's a good plane. Though the design has yet to be proven, the price is less...so it's worth a look."

Craftsman #27994 Corded Drill

Performance: 4, Value: 4

"Craftsman got smart and has introduced a corded drill that is the best of both (corded and cordless) worlds."

Bosch RA1200 Router Table

Performance: 4, Value: 3

"...Bosch thought of a lot of things to make this a useful router table...while it's got lots of nice features, the \$350 price tag makes us think again about the economy of making our own."

Review of Benchtop Mortisers

Editor's Choice to: Multico PM12.

Best Buys to: Bridgewood HM-11 and Grizzly G3183.

December 2001, Issue #125

Porter-Cable 9290 Cordless Router

Performance: 5, Value: 4

"...(T)he tool is a little pricey, but we like it. It performs well and is amazingly convenient."

Gross Stabil PC² Clamps

Performance: 5, Value: 3

"This clamp feels good, operates well, has improved versatility and is priced to compete."

Tool Dock Modular Workshop

Performance: 3½, Value: 3

"...(A) nice system that offers lots of good ideas for anyone looking to set up shop with little fuss and mess."

Best New Tools of 2001:

Bosch 1617EVSPK router kit.

Makita RF1101KIT router kit.

Bridgewood TSC-10CL contractor saw.

Clifton bench planes.

Craftsman #27994 corded drill.

Craftsman laser miter saw.

Porter-Cable 9290 cordless router.

Bench Dog MLF360 miter gauge.

Delta 22-580 2-speed planer.

Grizzly G9900 dial protractor.

Powermatic 719A mortiser.

Milwaukee BodyGrip router.

Veritas low-angle spokeshave.

Lie-Nielsen 60½R rabbit block plane.

Shop Fox W1671 mortiser.

Triton Multi-stand.

February 2002, Issue #126

Makita BO6030 & BO6040 Sanders

Performance: 4, Value: 4

"Both of these sanders are a pleasure to use and are strong performers."

DeWalt D51238K Brad Nailer

Performance: 4, Value: 2

"DeWalt has entered the (brad nailer) race with a good tool with smart options."

Delta 22-580 Two-Speed Planer

Performance: 5, Value: 3

"This is a well-equipped and versatile planer that is priced a little high, but offers a lot for the money."

Ridgid EB4424 Belt Spindle Sander

Passed the Endurance Test.

Review of Contractor Table Saws

Editor's Choice to: Delta 36-426, Jet JWTS-10PF and Powermatic 64A.

Best Buy to: Bridgewood TSC-10CL.

April 2002, Issue #127

HTC Multi-fence Systems

Performance: 5, Value: 4

"Without a doubt, the HTC fence improves on Biesemeyer's highly successful design."

Bosch 1619EVS Plunge Router

Performance: 4½, Value: 3½

"...(W)e feel the features and the performance of this tool justify the price, and make this a valuable tool."

Milwaukee BodyGrip Router

Performance: 5, Value: 5

"...(A) nicely appointed, well-crafted router that is...easy to adjust when in a table."

Stanley ZAG Folding Workbench

Performance: 4, Value: 4

"This handy accessory makes a versatile and useful addition to any home workshop."

Grizzly G1023S Cabinet Saw

Passed the Endurance Test.

Review of #5 Jack Planes

Editor's Choice: Lie-Nielsen.

Best Buy to: Stanley Type 11 (vintage).

CAPTION THE CARTOON

Illustrated by Bob Rech
bobrech@juno.com



#54

We Now Take E-mail Entries!

Submit your captions for this cartoon by e-mailing them to cartoon@fwpubs.com (be sure to put "Cartoon Caption #54" as the subject of your e-mail). Or send it to us on a postcard: *Popular Woodworking*, Cartoon Caption #54, 1507 Dana Ave., Cincinnati, OH 45207 by **August 15**. Winners will be chosen by the editorial staff.

The winner will receive the new Freud FJ85 Jigsaw with Electronic Cruise Control. This variable speed, 6-amp, orbital jigsaw offers toolless blade change and the cruise control keeps the blade speed constant under different loads to provide a finer, faster cut. The runners-up each win a one-year subscription to *Popular Woodworking*.

freud[®]



#52

"Nick, the pointy things seem to help!"

Rusty Cheek, of Rockford, Ohio, is the winner of our Cartoon Contest from the February issue and recipient of the Freud jigsaw. The following runners-up each receive a one-year subscription to *Popular Woodworking*:

"What's this? The 'Texas Handsaw Massacre'?"

Dawanas King, Kernersville, North Carolina

"You know Nick, now my saw kind of reminds me of you: not the sharpest tool in the shed!"

Elizabeth White, Santa Barbara, California

"Now I've seen everything... a crosscut saw, a ripcut saw and a no-cut saw."

Gary Cooper, Wenatchee, Washington

Increase Workshop Efficiency!

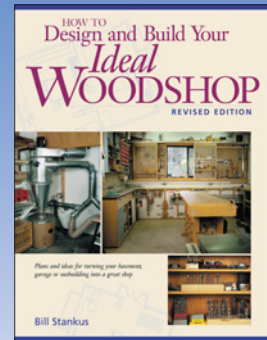

This newly-revised detailed instruction book by Bill Stankus pools the knowledge and expert advice of hundreds of woodworkers into one step-by-step guidebook to help you create the safest and most efficient workshop possible.

More than 100 color photographs and a wide range of floor plans will help you choose the arrangement that best fits your workshop—whether it's in a closet, basement or garage. And detailed instructions with a focus on safety take the guesswork out of planning your perfect shop.

Order your copy of *How to Design and Build Your Ideal Woodshop* today!

#70522-K/\$27.99/128p/ pb/275 color images

Available at your favorite bookseller or directly from the publisher using the Order Form below.

ORDER FORM

YES! Please send me _____ copy(ies) of
How to Design and Build Your Ideal Woodshop
(#70522-K) \$27.99 each

SUBTOTAL: \$ _____

In the U.S. please add \$3.95 shipping and handling for the first book, \$1.95 for each additional book. In Ohio and New York, please add applicable state tax. In Canada, add US\$5.00 shipping and handling for the first book, US\$3.00 for each additional book, and 7% GST. Payment in U.S. funds must accompany order.

TOTAL: \$ _____

Check or money order enclosed -or-
 Charge my VISA MC AmEx
Acct.# _____

Expiration date _____

Signature _____

Name _____

Address _____

City _____

State/Prov. _____ ZIP/PC _____

Send to:  Popular Woodworking Books
PO Box 9274
Central Islip, NY 11722-9274

ZAD02PW

For more information or to order by Credit Card visit
www.popularwoodworking.com/store/books
or call toll free 1-800-221-5831

Snakes, Scrap Wood and Justice

How I rid my shop of scraps and the highways of a questionable driver – all in a weekend.

Junk. Call it something else, but in the end, a rose by any other name takes up just as much room in your shop. What might start as a petite box of cutoffs invariably grows, until it threatens the security of your table saw, workbench and neighboring counties.

As woodworkers, we view this heap as a symbol of prowess – a reminder of the great things we have built and the foundation of greater things to come. We shape it, mold it, pluck choice morsels from it – but under no circumstances will we discard it. Wives, on the other hand, view our collection with detachment. While it may be an eyesore, as long as they can walk by without risking major injury, they will tolerate it. But just let one snake crawl out from under it and...

I was first alerted to the “situation” as my wife sat on the shop steps, enjoying her morning cigar. It began with a shriek, followed by a gasp and heavy footsteps, then the all-too-familiar sound of a shotgun being cocked. I peeked through the screen door to see Helga leveling a 12 gauge at the base of my table saw – I shrieked and then gasped.

Only traveling salesmen or a snake could evoke such a response. After a tense hostage negotiation, she surrendered her weapon and ran inside to defend the children. I relocated the unwanted guest to the neighbor’s yard and swaggered inside, the intrepid defender of both house and shop.

“That CRAP has got to GO! TODAY!!!” she says. Now, any of you who have been married longer than 45 minutes know that the way a woman says something is much more important than *what* is actually said.

Based solely on her tone, it was clear my weekend would be spent shoveling out my shop. I began the odyssey by borrowing my brother John’s pickup.

The little truck looked like a rental car from the Beirut airport. With favorable winds it could almost achieve freeway speeds – a safety feature considering the brakes worked on only one side.

After four hours of backbreaking labor, the “junk” was loaded. Scraps burgeoned from the bed, dangled over the sides and drooped down to nearly reach the ground. The truck was reminiscent of a burro laden for the Grand Canyon – a 70-year-old, half-blind burro with a hang nail and a case of hemorrhoids. I drove off to an uncertain destiny.

I completed the 15-mile trek to the municipal dump in 2 hours and 17 minutes, a personal best for this vehicle. The smell of rotting upholstery slowly gave way to the sweet aroma of the landfill as I cut across two lanes of traffic to make a wide right turn. Alarmed by the squeal of tires and the sound of all hell breaking loose behind me, I stood on the brakes and the truck rolled to a gradual halt.

The culprit was an El Camino that had lost its payload of aluminum cans while trying to enter the recycling facility. Clearly he was just another lead-footed maniac who had tried to take the turn too fast. In typical old man fashion, I raised my hand to my mouth, giving the international signal for, “How much have you had to drink?” He returned a different universal gesture, indicating he’d only had “one” – I doubted that as I left him to reclaim his cargo.

I backed into the depot and, owing to its weak suspension, the junk practically unloaded itself. The hardest part was ensuring that no part of the truck was inadvertently discarded. I swept down the bed and was ready to go. It was then that the El Camino pulled in behind me.

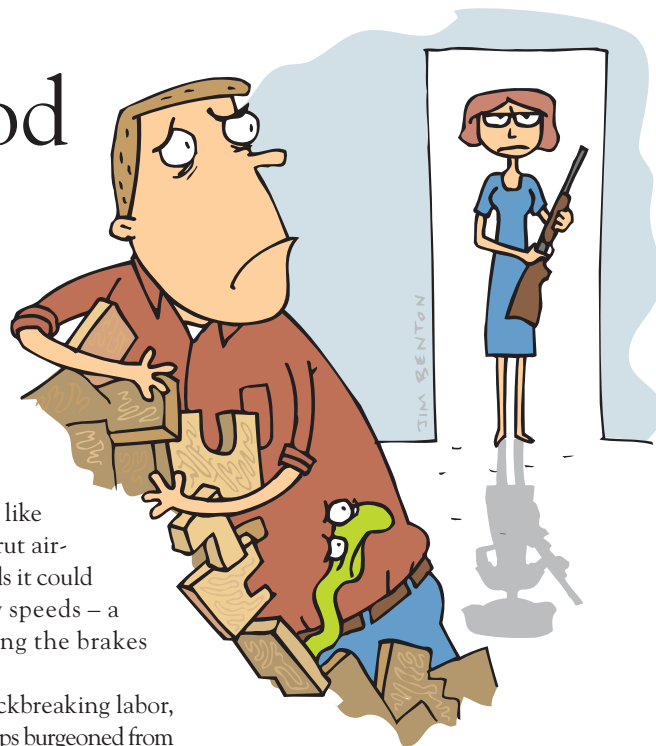

A dense hail of profanity filled the air as he emerged from his car. He paused briefly to gasp for air and to grab cans that continued to fall to the ground, stuffing them back in through the window.

I wished for a moment that I’d brought the shotgun...or the snake.

By the time the police arrived his eyes were red with rage and he was roaring incomprehensibly, punctuating each “statement” by slamming his hand down on the hood. But as with all hurricanes, he eventually ran out of wind. And, as the officer approached us, he threw open his car door to leave and the empty cans tumbled to the ground around him.

This gave the uniformed representative pause. “Have you been drinking, sir?”

For the first time that afternoon, he was speechless, so I decided I would help him, “He told me he’d only had one.” And with that I jumped back in the truck and headed home, not waiting for the inevitable “tests of manual dexterity” and the “Breathalyzer.” To be sure, I didn’t make any new friends that day, but I did clear out the garage, eliminate a nest of snakes, satisfy my wife and maybe – just maybe – I made the road a safer place for all of us. **PW**

Walt Akers is actively creating more hiding places for wayward reptiles in his workshop in Seaford, Virginia.

More power. More capacity.

Turbo III Dust Extractor



Introducing the **NEW FEIN Turbo III Portable Vac.**

The new 9-77-25 makes dust-free sanding and wet/dry cleanup easy and practical. The perfect size for big jobs, the Turbo III features 14.5 gallon capacity, an automatic on-off switch and a three-second hose-cleaning delay. The powerful two-stage motor offers bypass cooling to prevent electrical damage and prolong the life of the motor. And with 10% more suction power than the Turbo II, it can run two 6" or one 8" Random Orbit Sander.

For more information and the name of a local dealer, visit us at www.feinus.com or call **1-800 441-9878**.

Finishing is just the beginning.

Fein Power Tools, Inc. 1030 Alcon Street Pittsburgh, PA 15220

CIRCLE NO. 105 ON FREE INFORMATION CARD.



Fein

Makita®

2-1/4 H.P.

INDUSTRIAL ROUTER KIT

KIT INCLUDES FIXED BASE ROUTER, PLUNGE BASE & ACCESSORIES

Powerful 2-1/4 H.P. (11 AMP) Makita Made Motor

Makita Sub-Base Accepts Industry Standard Template Guides

Accessories Included: 1/2" and 1/4" Collets, Dust Nozzle Assembly, Straight Guide, Clear Sub-Base, Wrenches and Plastic Tool Case



Model RF1101KIT

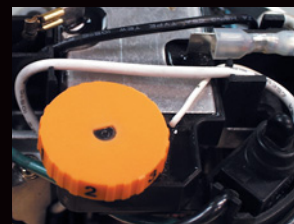

Electronic speed control with soft start provides smooth start-ups and maintains constant speed under load



Variable speed control dial (8,000 - 24,000 RPM) to match the speed to the application



Cam-lock lever for fast, easy and secure depth adjustment



Conveniently located plunge lock lever for efficient operation



For more info, call 1-800-4MAKITA or visit www.makitatools.com

EVERYTHING YOU NEED