

Roll out the lollies

What you will need

Item	Part	Size	Material
A	Case sides (makes 2)	90 x 19 x 500mm	Maple
B	Case bottom	90 x 19 x 210mm	Maple
C	Roller	35mm dia x 250mm	Dowel
D	Catcher	45 x 25 x 172mm	Maple
E1	Top ramp	45 x 30 x 90mm	Maple
E2	Top ramp	45 x 25 x 50mm	Maple
F	Base	140 x 19 x 220mm	Maple
G	Bottom ramp	19 x 12 x 75mm	Maple
H	Ramp sides (2)	35 x 19 x 75mm	Maple
I	Posts (2)	35mm dia x 50mm	Dowel
J	Top	100 x 19 x 220mm	Maple
K	Top plate	60 x 19 x 180mm	Maple
L	Lid handle	40 x 19 x 140mm	Maple
M	Knobs (2)	55 x 55 x 19mm	Maple

This sweet dispenser has its rewards

Remember putting coins in bubblegum machines and waiting to see what colour would roll out? By using offcuts from the workshop you can make your own lolly dispenser, and save your coins. It's designed for round sweets about 18mm in diameter. As most sweets are not perfectly round, there may be the occasional jam, but a pin-ball style 'tilt' will get the rewards flowing again.

Most of the smaller parts of the unit are odd sizes and shaped from larger stock. For the components that need to be shaped, it's easiest to clamp longer lengths to the table while shaping, then cut to length. You will also need 6mm dowels, 6mm dowel centres and assorted screws.

rotate freely in the holes, and ease with a small drum sander if necessary.

Step 2 Draw a line across the top of the hole, and another 6mm above. Mark the position of two dowel holes 12mm in from the grooves and drill 6mm diameter by 10mm deep holes.

Step 3 Screw the case bottom (B) to the sides after predrilling 10mm in from each edge to avoid the grooves in the sides. Cut the roller (C) to length – it is cut long so it can slide from side to side as well as turn. Measure 105mm from one end, and drill a 19mm-diameter hole to a depth of 15mm.

Step 4 Before cutting the catcher (D) to length, mark the curve from the template to the edge face

Here's how

Step 1 Set a power saw to cut a 6mm deep by 3mm wide groove 19mm from each edge of the case sides (A), leaving a 46mm-wide section between grooves. Cut the two sides to length. Mark 100mm up from the base of each side, find the centre and drill through both pieces with a 35mm spade bit. When the point just appears through the back, drill back from that side. Check a 35mm dowel will

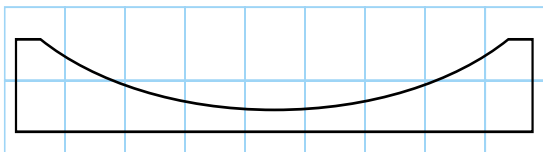
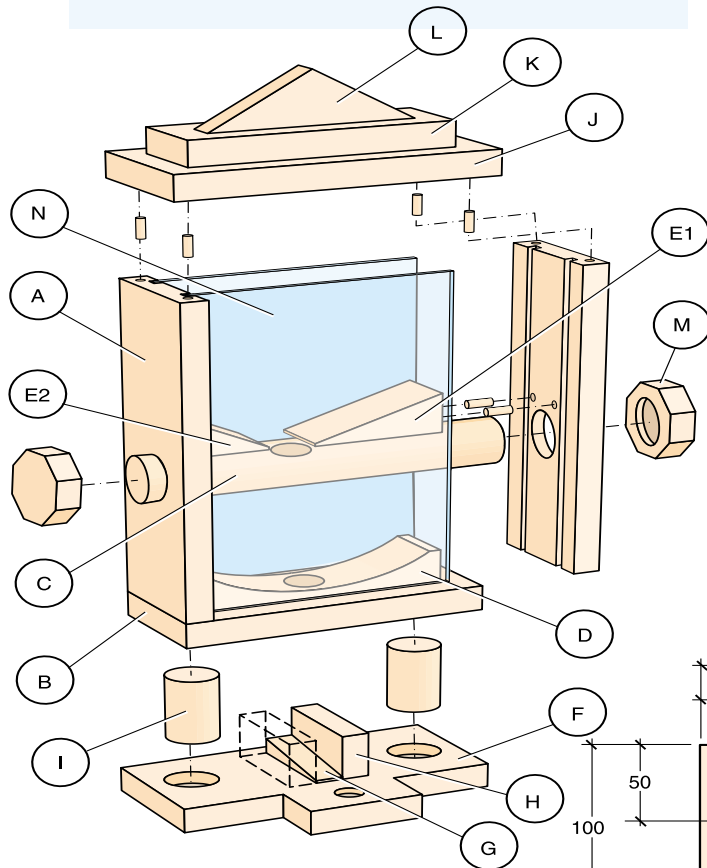

20mm grid

Item D

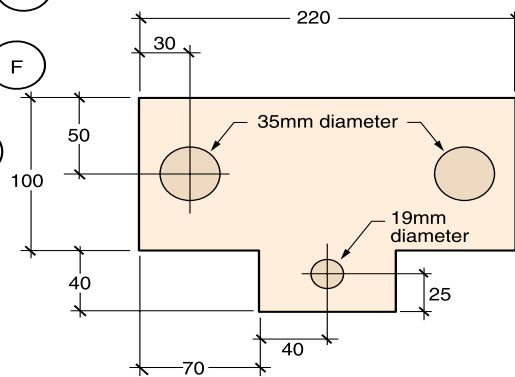

Item F

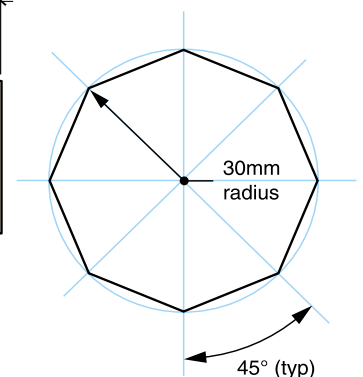

Item M

Roll out the lollies (cont)

bandsaw if you have one). Then cut to length and sand smooth. Glue to the case bottom. From the underside, find the centre and drill a 19mm hole through bottom until the point appears at centre of catcher. Turn over and complete the hole.

Step 5 Mark diagonally and cut the wedge shapes for the top ramps (E1, E2), leaving about 2mm at the points. Cut with a handsaw and sand smooth. Fit a pair of 6mm dowel centres into the holes in the case sides and carefully align the ramps so they clear the roller holes by 1mm. Press to mark the dowel hole centres in the ramps. Drill 6mm by 10mm deep holes. Cut 18mm-long dowels, glue into the ramp holes and then into the sides. Feed in the roller to make sure it is free to rotate and ensure the ramps are parallel with the roller.

Step 6 Prepare the base (F) using the diagram for dimensions. Locate the centre of the post holes and drill 35mm by 10mm deep holes. Also drill a 19mm hole to a depth of 5mm as the lolly receptacle. On the underside of the case bottom, measure 25mm in from each side, find the centre, then drill 35mm by 5mm deep holes. Use a round-over bit in a router to round the side and bottom edges of the case and the top edges of the base.

Step 7 Cut the angle on the bottom ramp (G) leaving a front lip of 2mm. Then cut it, the ramp sides (H) and posts (I) to length. Position the ramp and sides on the base and place the posts in holes. The difference in height should be 5mm.

Adjust if necessary. Draw a line 12mm from the back edge of the base and glue on the ramp and ramp sides with their back edges centred along this line. Glue the posts in place then glue case to the base. Clamp until glue sets.

Step 8 Prepare the top (J), plate (K) and handle (L). Find the midpoint of the handle, join to bottom corners and cut the angles. Round all edges of top and top edges only of plate. Screw the plate to the handle and the top to the plate, centring each time.

Step 9 Drill a 6mm diameter by 10mm deep dowel hole 10mm in from the top corner of each case side. Push in dowelling centres, align top and mark dowel holes in top. Drill to 10mm deep. Glue 18mm-long dowels into the top only and let dry. Round over dowel ends and open dowel holes in sides to 7mm.

Step 10 Mark out the octagonal knobs (M) by drawing eight axes and measuring 30mm along each. Join up the points and cut out with a jigsaw. Sand all sides smooth, then hold in a vice and cut a 35mm diameter by 5mm deep recess in centre for fixing to the roller ends. Slide the perspex (N) into the grooves and locate top in dowel holes. Do a trial run with some sweets to see if it operates properly. It may be necessary to slightly dish hole sides and ends of ramps for more reliable operation.

Step 11 Separate the loose components, sand smooth any rough areas and sharp edges, then spray

with several coats of clear polyurethane. Reassemble and screw the knobs to the roller using brass screws. on the ramp and ramp sides with their back edges centred along this line. Glue the posts in place then glue case to the base. Clamp until glue sets.

