



Telephone Table

We have a kitchen wall phone, but had nowhere to sit and write. This telephone table serves the purpose nicely. It's a snap to make and serves as a very convenient area for phone books, notepads and writing instruments.



Materials

- 7 linear feet of 1 x 6 pine
- 3 linear feet of 1 x 12 pine
- 5 linear feet of 3" chair rail molding
- 2 newel posts*

Hardware

- 20 1" long nails
- 24 1-1/2" screws
- 12 2-1/2" screws

Cutting List

Code	Description	Qty.	Materials	Dimensions
A	Top	1	1 x 12 pine	24" long
B	Front/Back	2	1 x 6 pine	24" long
C	Side	2	1 x 6 pine	12-3/4" long
D	Leg	2	Newel posts*	39" long
E	Trim	3	3-inch chair rail molding	Cut to fit

***Notes on Materials**

We purchased newel posts at a building supply store, turned them upside down, and used them for the legs. If you can't find the exact kind we used, you can substitute a 4 x 4 and attach a fence-post finial on the end--or simply use a 4 x 4 by itself. Just make certain that the total length of the leg is 39 inches.

Making the Table Top

1. Cut one top (A) from 1 x 2 pine measuring 24 inches long.
2. Cut two front/back (B) from 1 x 6 pine, each measuring 24 inches long.
3. Cut two sides (C) from 1 x 6 pine, each measuring 12-3/4 inches long.
4. Place the top (A) on a level surface. Place the two front/back (B) on edge on either side of the top (A), matching the 24-inch-long sides, as shown in *Figure 1*. Apply glue on the meeting surfaces, and screw through the front/back (B) into the edges of the top (A) using six evenly spaced 1-1/2-inch screws on each joint.
5. Place the two sides (C) over the ends of the two front/back (B), as shown in *Figure 2*. Apply glue on the meeting surfaces, and screw through the sides (C) into the ends of the front/back (B), using three 1-1/2-inch screws on each joint.

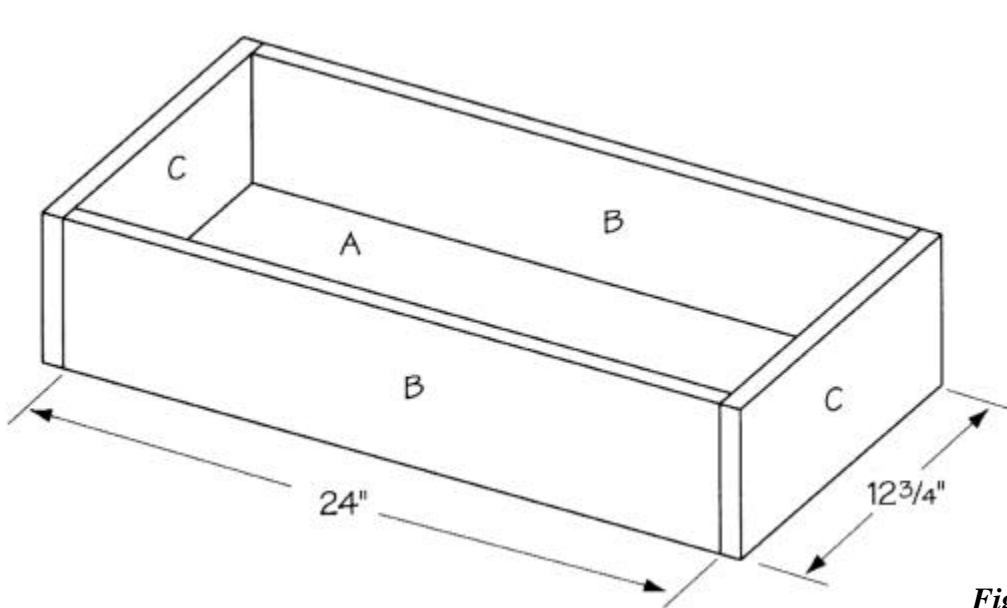

Figure 1

Adding the Legs

1. Trim the two legs (D) to 39 inches long.
2. Place the legs (D) inside the table assembly, as shown in *Figure 2*. Note that both legs (D) are attached to the same front (B). Apply glue on the meeting surfaces, and screw through the front (B) and sides (C) into the legs (D) using two 2-1/2-inch-long screws on each joint. After driving each screw, use a try square to make sure that the legs (D) remain at right angles to both front (A) and side (C). Also screw through the top (A) into the legs (D) using two 2-1/2-inch screws on each leg (D).

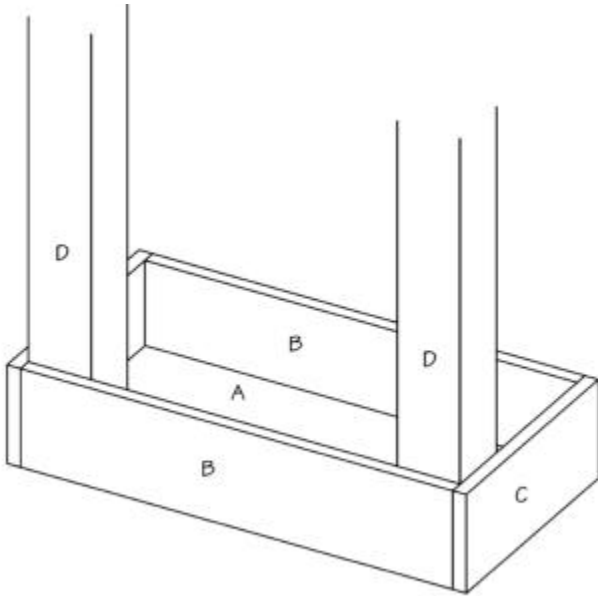

Figure 2

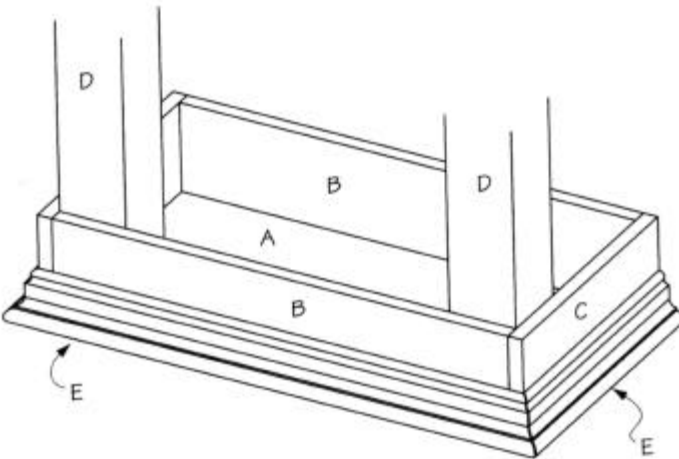

Figure 3

Finishing

1. Measure carefully, and cut outer trim (D) from 3-inch-wide molding, as shown in *Figure 3*, mitering the molding at each of the corners. Do not attach molding to the back of the telephone table, as the back will be attached to a wall. Apply glue on the meeting surfaces,

and nail through the outer trim (D) into the front, back, and sides (A and B). Use 1-inch (2d) finishing nails spaced about every 4 inches.

2. Fill any screw holes or imperfections in the wood with wood filler.
3. Thoroughly sand the telephone table.
4. Stain or paint the table the color of your choice. Since we use it in our kitchen, we chose a bright white paint to coordinate with our other kitchen items.
5. Use molly bolts or other appropriate hardware to secure the finished table to a wall.



Need more room? Build your own kitchen island from www.wowimadeit.com

Face facts! If you're preparing food while guests or family are in the house, chances are good that you'll have an audience. Because we enjoy relaxed entertaining, and especially kitchen company, our kitchen hutch, island and telephone table are designed to serve as coordinated pieces. (The island and telephone table also serve as "people perches.") A plate of appetizers on the island and self-serve beverages on the telephone table make everyone feel at home while we finish preparing the meal.