



Wow! I Made It.com

Desk Cabinet

My son needed a desk for studying, but finding enough space in his room among the golf clubs, baseball cards, girlfriend's pictures, painting ease, and basketball hoops was difficult. To solve this problem, we came up with a project that provides a large surface when the desktop is extended, but that saves space when it's closed.



Special Tools

- Two pipe clamps
- Router: although it's possible, making this project without a router is difficult and time consuming. If you don't own a router, we suggest that you borrow one from a friend.

Materials and Supplies

- 3 linear feet of $\frac{3}{4}$ x $\frac{3}{4}$ pine
- 9 linear feet of 1 x 3 pine
- 16 linear feet of 1 x 4 pine
- 9 linear feet of 1 x 12 pine
- $\frac{3}{8}$ "-diameter dowel rod, at least 2" long
- 3 pieces of laminated pine, each measuring 30" x 36"
- 1 piece of $\frac{3}{4}$ -thick plywood, 30" x 40"

Notes on Materials

The sides, cabinet doors, and desktop are constructed of laminated 1 x 4 pine boards. Most building-supply stores sell sections of pine that have already been laminated. You can laminate the boards yourself, of course, but I don't recommend doing so unless you're an experienced woodworker and have the necessary tools.

Hardware

- Approximately 200 #6 x 1-1/4" flathead wood screws
- Approximately 10 3d finishing nails
- Two round cabinet knobs for the front of the cabinet
- 2 rectangular cabinet pulls with recessed and hinged handles
- 2 concealed cabinet hinges

Cutting List

Code	Description	Qty.	Material	Dimensions
A	Desktop	1	Laminated pine	23-1/2" x 35-3/4"
B	Desktop Brace	2	1 x 3 pine	6" long
C	Dowel Rod	2	$\frac{3}{8}$ " dowel rod	1" long
D	Desktop Front	1	1 x 4 pine	35-3/4" long
E	Desktop Support	2	1 x 4 pine	2-3/4" long
F	Desktop Inner Support	1	$\frac{3}{4}$ x $\frac{3}{4}$ pine	34-1/4" long

G	Side	2	Laminated pine	15" x 29-1/2"
H	Back	1	3/4" plywood	29-1/2" x 37-1/2"
I	Inner Support	6	1 x 3 pine	9-3/4" long
J	Shelf	2	1 x 12 pine	36" long
K	Top	1	1 x 12	36" long
L	Top Support	1	1 x 4 pine	34" long
M	Trim	3	1 x 4 pine	36" long
N	Bottom Trim	1	1 x 3 pine	36" long
O	Cabinet Door	2	Laminated pine	17-3/4" x 25-1/4"

Making the Desktop

1. Cut one 23-1/2" x 35-3/4" desktop (A) from laminated pine.
2. Cut two 6"-long desktop braces (B) from 1 x 3 pine.
3. Attach one desktop brace (B) to the desktop (A), as shown in *Figure 1*, using glue and two 1-1/4" screws. Note that the ends of the desktop brace (B) and the desktop (A) are flush and that the 6"-long edge of the desktop brace (B) is flush with the 35-3/4"-long edge of the desktop (A).

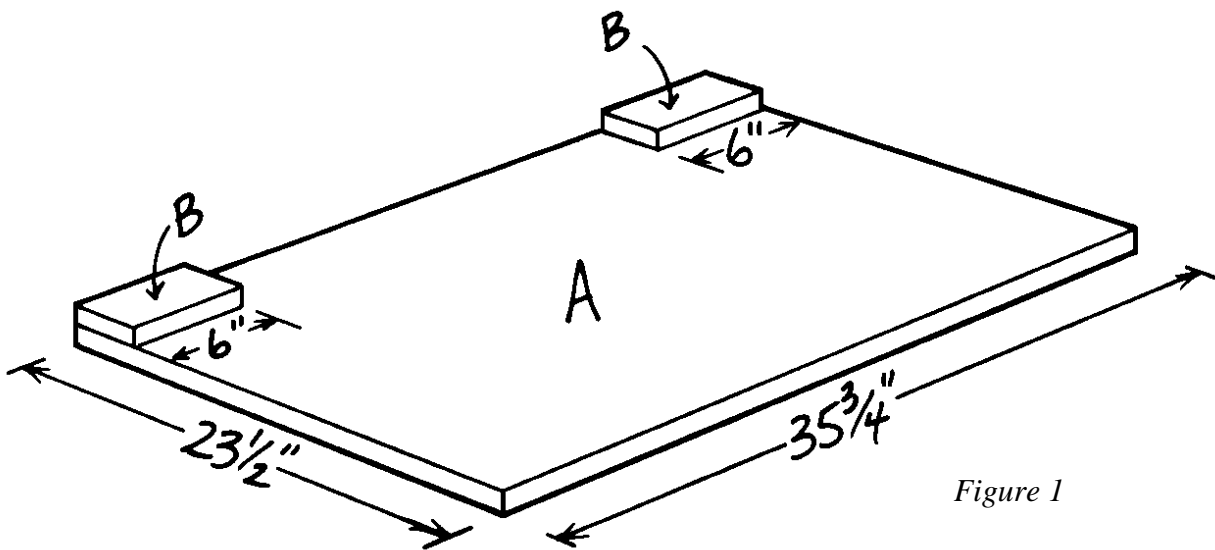

Figure 1

4. Repeat Step 3 to attach the remaining desktop brace (B) to the opposite end of the desktop (A).

- Each of the desktop braces (B) must now be drilled to accept a dowel rod (C). Using the placement dimensions given in *Figure 2*, drill a $\frac{3}{8}$ "-diameter hole, $\frac{1}{2}$ " deep, in the end of one desktop brace (B).

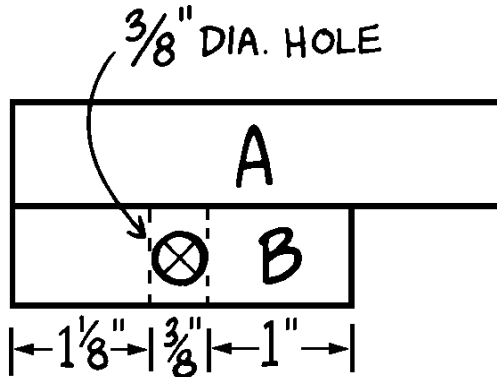

Figure 2

- Repeat Step 5 to drill a $\frac{3}{8}$ "-diameter hole, $\frac{1}{2}$ " deep, in the end of the other desktop brace (B). The second hole must be drilled as a mirror image of the first hole.
- Using a router and roundover bit, round the $35\text{-}\frac{3}{4}$ "-long edge of the desktop (A) to which the desktop braces (B) are attached, as shown in *Figure 3*.
- Cut two 1"-long of $\frac{3}{8}$ "-diameter dowel rod (C).

- Apply glue to one end of each dowel rod (C) and insert the rods into the holes drilled in the desktop brace (B). Each rod should protrude $\frac{1}{2}$ " from its hole
- Cut one $35\text{-}\frac{3}{4}$ "-long desktop front (D) from 1 x 4 pine.

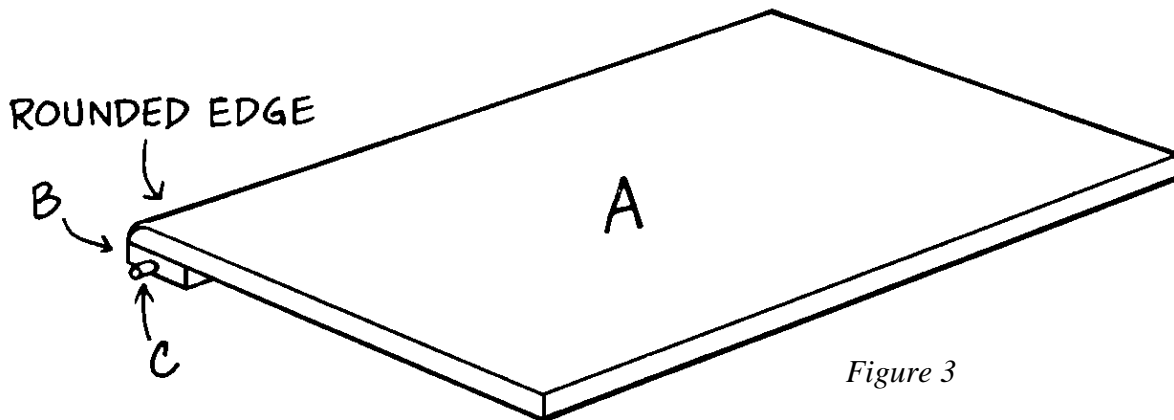

Figure 3

- Glue the desktop front (D) to the unrouted $35\text{-}\frac{3}{4}$ "-long edge of the desktop (A), as shown in *Figure 4*. Secure the desktop front (D) by driving $1\text{-}\frac{1}{4}$ " screws spaced about 6" apart, through its face and into the edge of the desktop (A).
- Cut two $2\text{-}\frac{3}{4}$ "-long desktop supports (E) from 1 x 4 pine.
- Glue one desktop support (E) flush with the ends of the desktop front (D) and the desktop (A), as shown in *Figure 4*. Drive two $1\text{-}\frac{1}{4}$ " screws through the face of the desktop (A)

into the edge of the desktop support (E) and two more screws through the face of the desktop front (D) into the end of the desktop support (E).

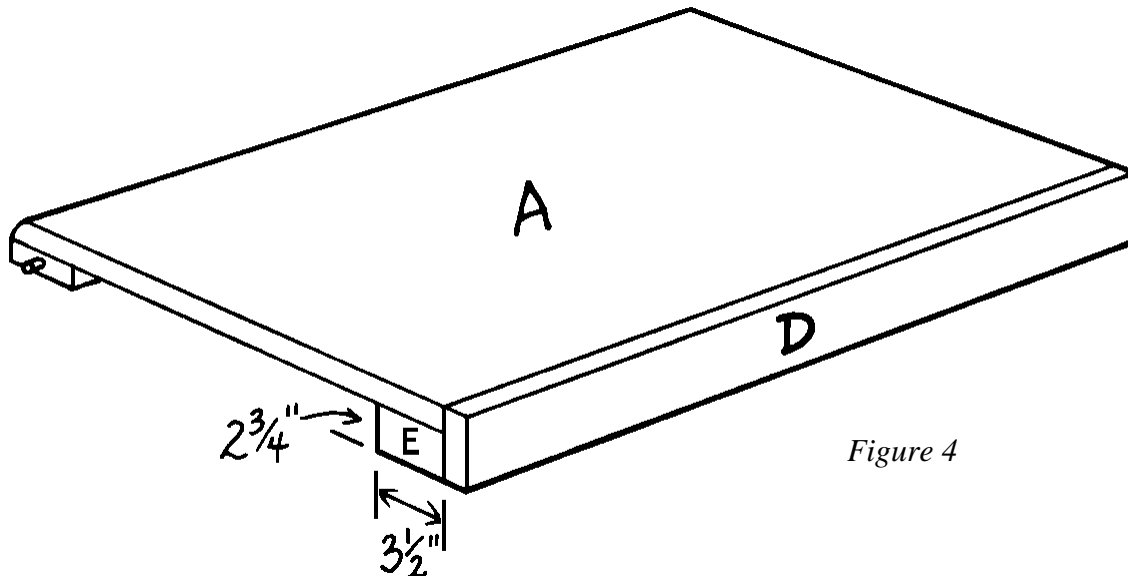
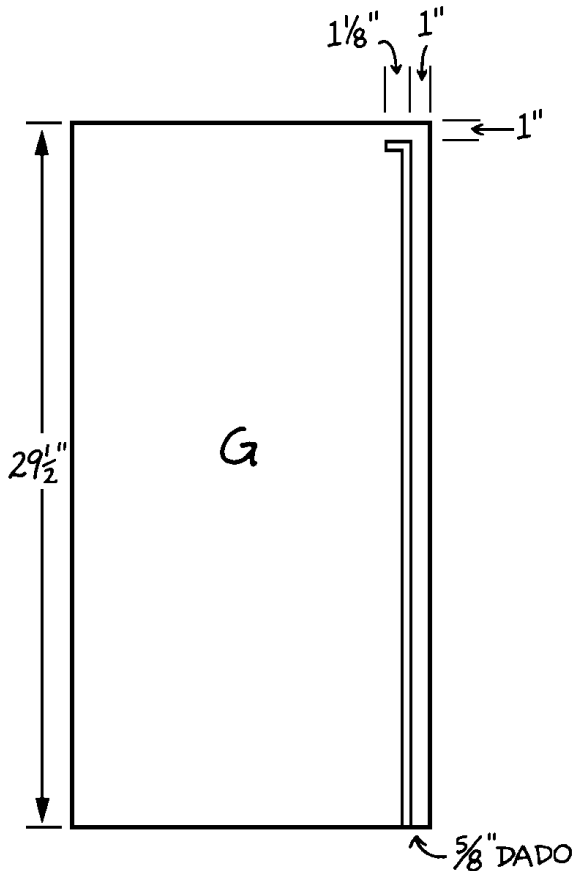

Figure 4

14. Repeat Step 13 to attach the remaining desktop supports (E) to the opposite ends of the desktop front (D) and the desktop (A).
15. Cut one 34-1/4"-long desktop inner support (F) from 3/4" x 3/4" pine.
16. Glue and nail the desktop inner support (F) between the two desktop supports (E), over the joint formed by the desktop (A) and the desktop front (D). Secure the support (F) to both the desktop (A) and the desktop front (D) by inserting 1-1/4" nails spaced about 4" apart, along its length.

Constructing the Outer Cabinet

1. Cut two 15" x 29-1/2" sides (G) from laminated pine.
2. A dado must be cut in each of the two sides (G) to accommodate the dowel rods (C) in the desktop assembly. Using *Figure 5* as a placement guide, cut a 5/8"-wide dado, 1/2" deep, 1" from one 29-1/2" edge of one side (G). Note that the dado stops 1" from the upper end of the side (G), turns 90 degrees and proceeds 1-1/8" further.
3. Repeat Step 2 to dado the remaining side (G), keeping in mind that the two dadoed sides (G) must be mirror images of each other when you're finished.
4. Cut one 37-1/2" x 29-1/2" back (H) from 3/4"-thick plywood.



5. At this point, you should perform what's known as a "dry assembly"—a temporary assembly using screws but no glue—to make certain that the desktop assembly will fit and slide easily inside the dadoes cut into the two sides (G). This particular step will be easier if you can a willing helper to assist.
6. First, using only as many screws as needed to hold the parts together, attach the back (H) over the edges of the two sides (G), as shown in *Figure 6*, with the mirror-image dadoes in the sides (G) placed at the back of the assembly. Insert the screws through the back (H) and into the edges of the sides (G). Now turn the assembly upside down.
7. To hold the open front edges of the sides (G) exactly 36" apart, attach two pipe clamps to them.
8. Now you need to test-fit the desktop assembly by slipping the dowel rods (C) protruding from its ends into the dadoes in the sides (G) of the cabinet. To do this hold the desktop assembly vertically over the partly assembled cabinet, with the top face of the desktop (A) facing the inner surface of the cabinet back (H) and the desktop front (D) facing down. Fit the dowel rods (C) into the dadoes in the two sides (G), and gently lower the desktop assembly into the cabinet.
9. Carefully turn the entire assembly right side up. Pull the desktop front (D) upward and forward towards the open front of the cabinet, making certain that the dowel rods (C) glide easily within the dadoes, and that the desktop assembly will rotate from a vertical to a horizontal position when you reach the top of the dadoes. If the movement isn't smooth, now is the time to correct it. You may have to enlarge the dadoes at places where the dowel rods (C) bind, sand down the rods slightly, or further round the back edge of the desktop assembly.
10. When the assembly works to your satisfaction, disassemble the structure, set the desktop assembly aside, and reassemble the back (H) and two sides (G), this time using glue and inserting 1-1/4" screws about 6" apart along the length of each joint.
11. Cut six 9-3/4"-long inner supports (I) from 1 x 3 pine.

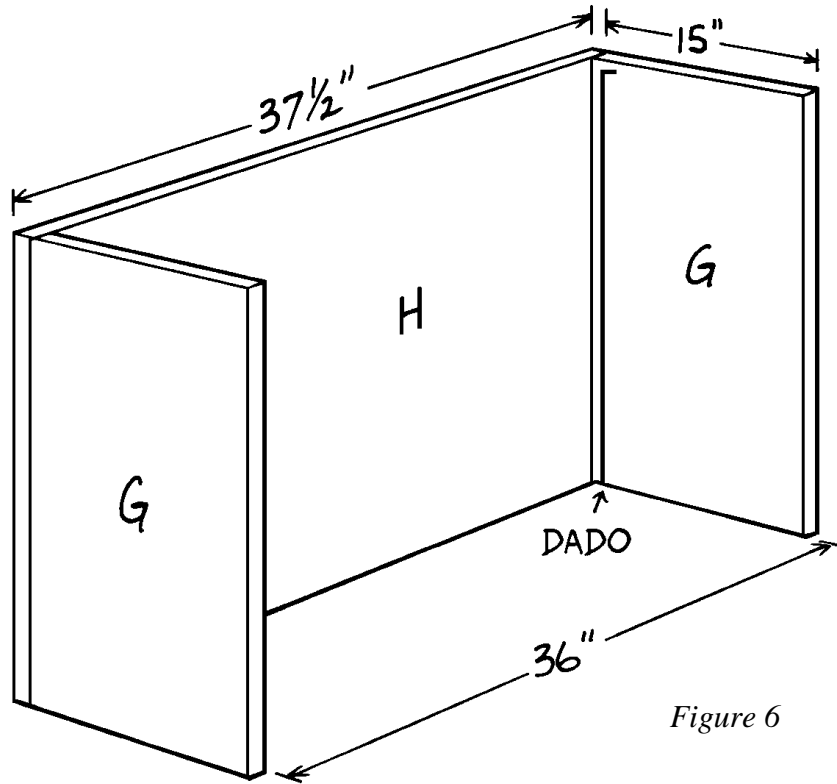

Figure 6

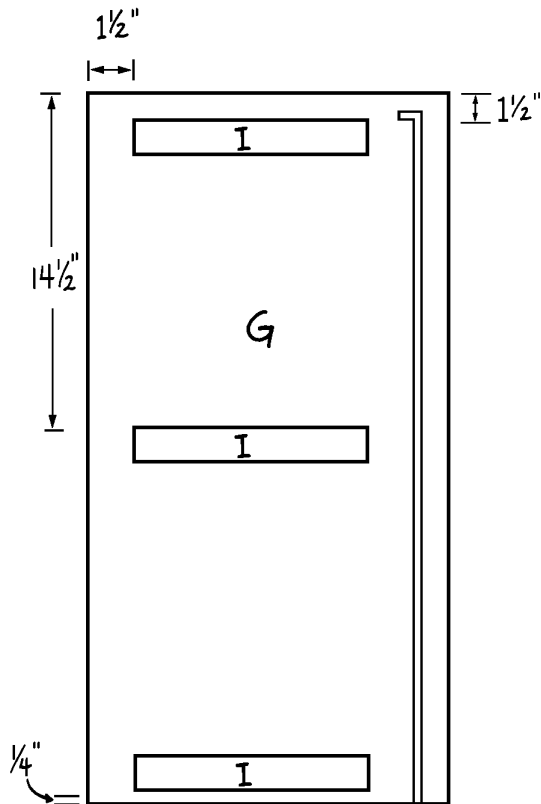

Figure 7

12. Using *Figure 7* as a placement guide, glue three of the inner supports (I) to one side (G). Position the first inner support (I) 1-1/2" from the upper end of the side (G); the second inner support (I) 14-1/2" from the same end; and the third inner support (I) 1/4" from the bottom end. Note that all three supports (I) should be 1-1/2" from the front edge of the side (G); they do not cover the dado at the back edge.
13. Repeat Step 11 to attach the remaining three inner supports (I) to the other side (G).

Installing the Shelves

1. Cut two 36"-long shelves (J) from 1 x 12 pine.
2. Install one shelf (J) between the two sides (G) and over the middle inner supports (I), as shown in *Figure 8*, placing the shelf (J) 1-1/2" from the front edges of the sides (G). Glue the

shelf (J) in place and insert three 1-1/4" screws through its face and into the edge of each inner support (I). Also insert screws through the side (G) and into the ends of the shelf (J).

3. Repeat Step 14 to attach a second shelf (J) over the lowest pair of inner supports (I), as shown in *Figure 8*.

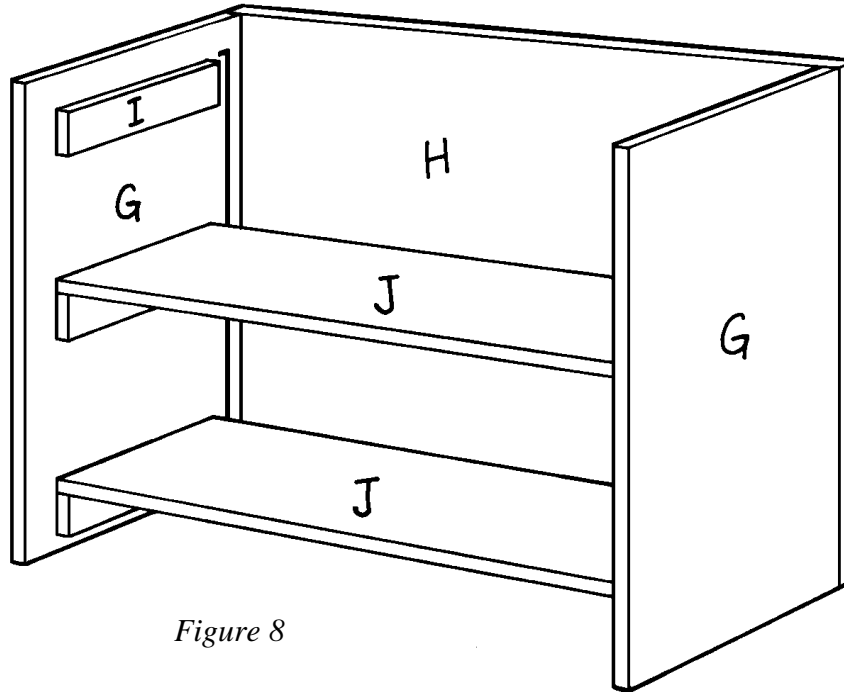

Figure 8

4. Cut one 36"-long top (K) from 1 x 12 pine.
5. Cut one 34"-long top support (L) from 1 x 4 pine. Set this piece aside; you'll add it to the top (K) during final assembly.
6. Attach the top (K) over the top inner supports (I), between the two sides (G) and flush with their front edges (see *Figure 9*).

Adding the Trim

1. Cut three 36"-long trim pieces (M) from 1 x 4 pine.
2. Glue one trim piece (M) to the front ends of the upper inner supports (I), between the two sides (G), as shown in *Figure 10*. Secure the trim (M) by driving two 1-1/4" screws through its face and into the end of each inner support (I). Also insert 1-1/4" screws, spaced about 6" apart, through the top (K) and into the trim piece (M).

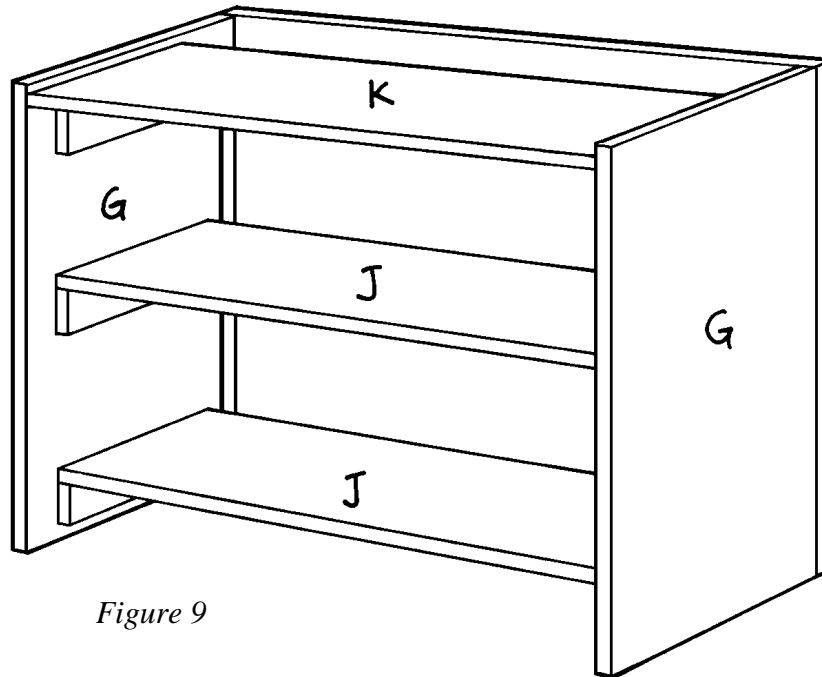

Figure 9

3. Glue the second and third trim pieces (M) to the two shelves (J) and the front ends of the middle inner supports (I), between the two sides (G), as shown in *Figure 10*. Secure with two 1-1/4" screws inserted through the face of each trim piece (M) and into the inner support (I) at each joint. Also insert 1-1/4" screws, spaced about 6" apart, through each trim piece (M) and into the edge of each shelf (J).

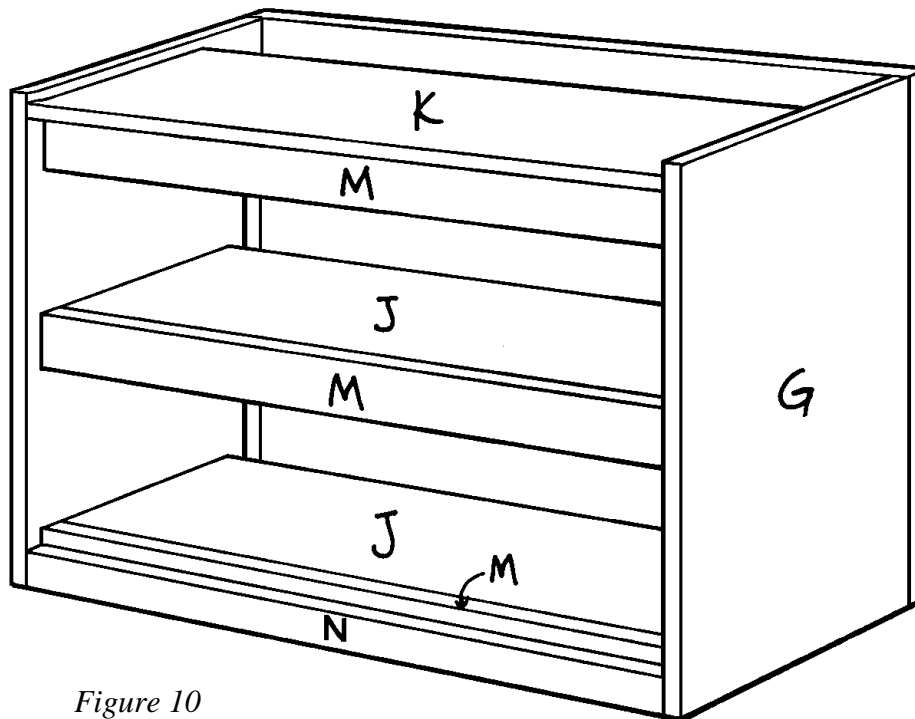
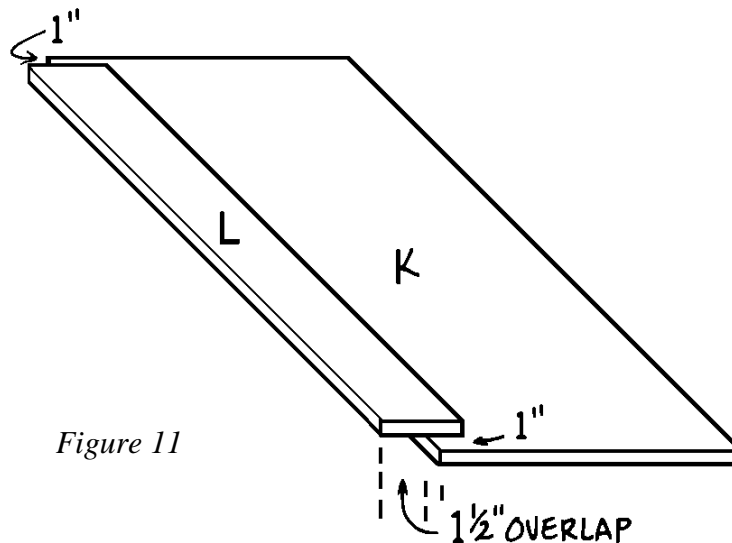

Figure 10

4. Cut one 36"-long bottom trim piece (N) from 1 x 3 pine.
5. Attach the bottom trim piece (N) between the two sides (G), flush with the bottom edge of the lower trim piece (M) and with the bottom of the cabinet, as shown in *Figure 10*. Insert 1-1/4" screws, spaced about 6" apart, to secure the bottom trim piece (N).

Installing the Desktop

1. Turn the completed desk/cabinet upside-down. Fit the assembled desktop, with the desktop front (D) facing down, into the opening in the back of the cabinet, fitting the dowel rods attached to the desktop assembly into the dadoes in the sides (G).
2. Now you'll attach the top support (L) to the top (K). The top support (L) serves to keep the desktop assembly from dropping all the way down into the cabinet when the desktop isn't in use. With the desk/cabinet still upside down, place the top support (L) on the 36"-long edge of the top (K) that is closest to the desktop assembly. Note that the top (K) is 1" longer than the top support (L) at each end. Make certain that the top support (L) overlaps the top (K) by 1-1/2", as shown in *Figure 11*. Then glue the top (L) in place and insert 1-1/4" screws, spaced about 4" apart, through it and into the top (K). Be sure to attach the top support (L) only to the top (K) and not to the desktop front (D).
3. Turn the desk/cabinet right side up.



Making the Cabinet Doors

1. Cut two 25-1/2" x 17-3/4" cabinet doors (O) from laminated pine.

2. Using a router and roundover bit, rout all four edges on what will be the front face of each door (O).
3. Fit the doors (O) into the opening at the front of the desk/cabinet, and check their fit. Then attach two concealed cabinet hinges to each of the doors (O) and to the inside of the desk/cabinet.

Finishing

1. Using a router and roundover bit, round both edges of the sides (G) and back (H) of the cabinet.
2. Fill all holes, cracks, and crevices with wood filler. Pay particular attention to the routed edges of the back (H) of the cabinet. Because it is plywood, it will require more filler than the rest of the cabinet.
3. Sand all surfaces of the desk/cabinet thoroughly
4. Paint or stain the project the color of your choice.
5. Install recessed drawer pulls on the desktop front (D).
6. Install one cabinet knob on each of the doors (O), being careful to align them with one another.

