



Thank you!

Thank you for ordering a Downloadable WOOD PLAN. We hope you enjoy being a part of this new online experience and that you have fun building your wood-working project.

Please remember that this copyrighted material is for your use only. It is unlawful to share this file with someone else or to reprint it in any form.

Bill Krier
Editor
WOOD® magazine

Adobe Acrobat Troubleshooting Guide

*If you can read this page, your Acrobat program is working correctly!
But you may still have problems or specific issues such as printing and saving your Downloadable WOOD PLAN.*

My printer won't print the text correctly

Almost all printing problems are due to not enough free system resources memory. The files are very memory intensive since they include graphics, text, and photos. Close all other programs/applications and print directly out of the Acrobat Reader program, not your Web-browser.

Patterns are not printing full size

Make sure your printer is set to print at 100% and that "print to fit" is not checked. These settings are selected in the printer setup or printer options.

I can't save my file now that it's downloaded

You must save the plan when you download the file. Download the file again, except this time try right-clicking on the red download button. A menu window will open. Select "Save target as" or "Save link as" to save the file to your hard drive. Once saved, you can open it with Adobe Acrobat Reader.

For more details on using Adobe Acrobat Reader please visit our online help section at:
<http://woodstore.woodmall.com/clicherforde.html>



If you're the type of person who spends the lion's share of your leisure time gardening and otherwise tending your yard, you'll appreciate this project. Made of long-lasting cedar, this backyard classic will gracefully accent your surroundings and serve as a comfortable place to contemplate the joys of your gardening chores.

Gardener's Retreat

A strikingly good-looking arbor with a built-in bench

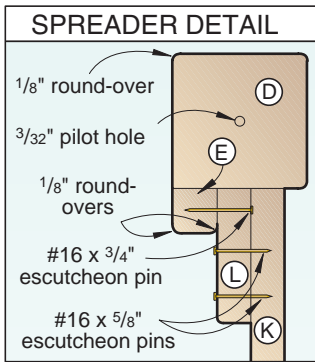

EXPLODED VIEW

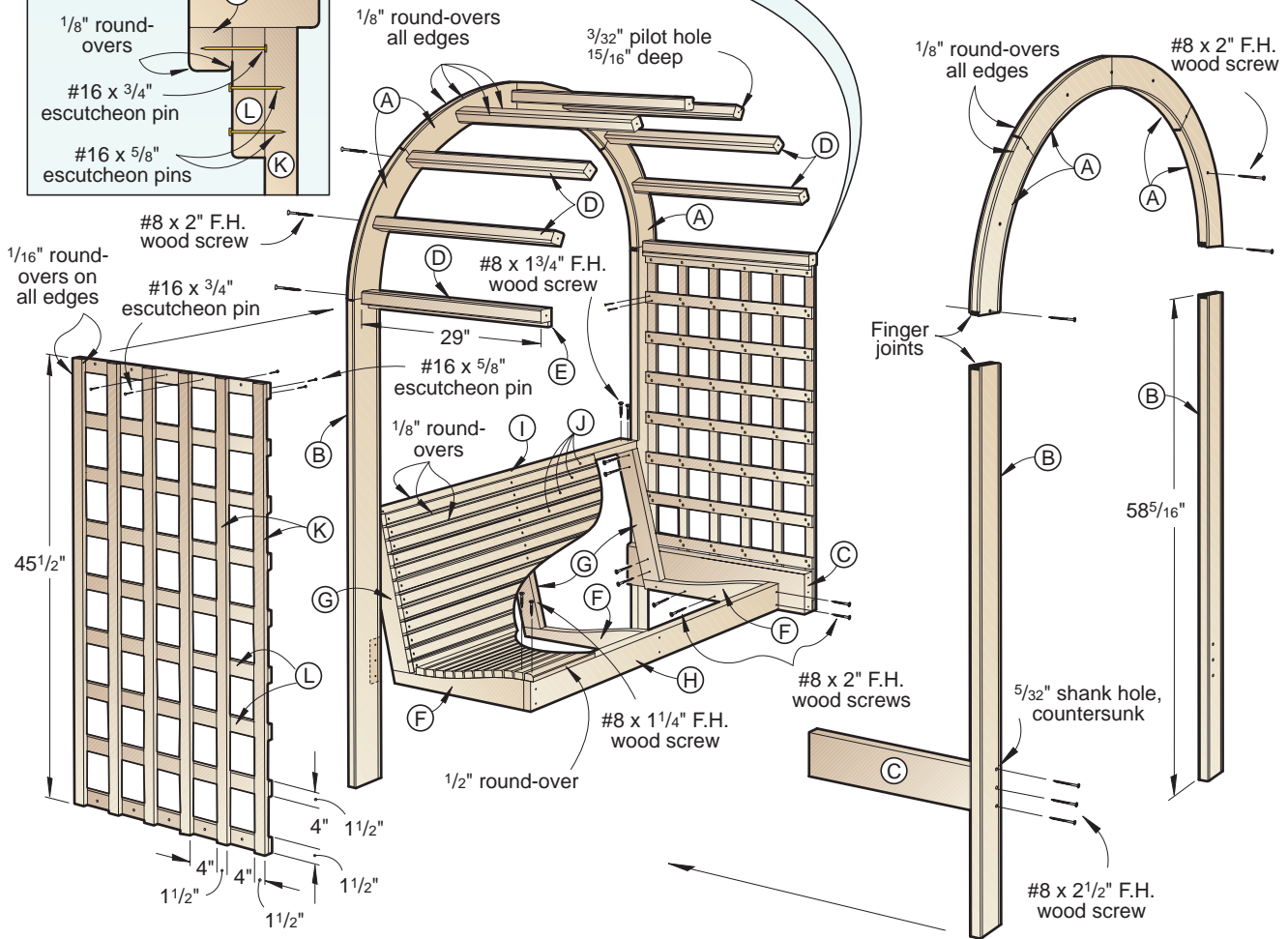

Bill of Materials

| Part | Finished Size | | | Matl. | Qty. | Part | Finished Size | | | Matl. | Qty. |
|------------------|---------------|--------|----------|-------|------|----------------------|---------------|--------|---------|-------|------|
| | T | W | L | | | | T | W | L | | |
| ARCHES | | | | | | SEATS | | | | | |
| A* arch segments | 1 1/16" | 5 1/2" | 20 5/16" | C | 8 | F* supports | 1 1/16" | 3 1/2" | 21 5/8" | C | 3 |
| B* arch uprights | 1 1/16" | 3 1/2" | 58 5/16" | C | 4 | G backrests | 1 1/16" | 3" | 20 1/2" | C | 3 |
| SPREADERS | | | | | | H front rail | 1 1/16" | 3 1/2" | 41" | C | 1 |
| C seat spreaders | 1 1/2" | 5 1/4" | 29" | C | 2 | I top rail | 1 1/16" | 3 1/2" | 41" | C | 1 |
| D spreaders | 1 1/2" | 1 1/2" | 29" | C | 9 | J slats | 3/4" | 1 3/8" | 41" | C | 24 |
| E cleats | 1/2" | 1/2" | 29" | C | 2 | LATTICE | | | | | |
| | | | | | | K vertical members | 3/8" | 1 1/2" | 45 1/2" | C | 12 |
| | | | | | | L horizontal members | 3/8" | 1 1/2" | 29" | C | 18 |

* Initially cut parts marked with an * oversized. Trim to finished size according to the instructions.

Material Key: C—cedar.

Supplies: #8x1 1/4", #8x1 3/4", #8x2", #8x2 1/2" flathead wood screws (preferably stainless steel), #16x5/8" brass escutcheon pins, #16x3/4" brass escutcheon pins, clear exterior finish.

Buying Guide

Finger-joint bit. Carbide-tipped cutters with 1/2" shank. Will cut finger joints in stock from 1/2" to 1 1/4" thick. Bit no. 7861, \$55 ppd. (contiguous U.S.). MLCS, P.O. Box 4053, Rydall, PA 19046. Or call 800/533-9298 to order.

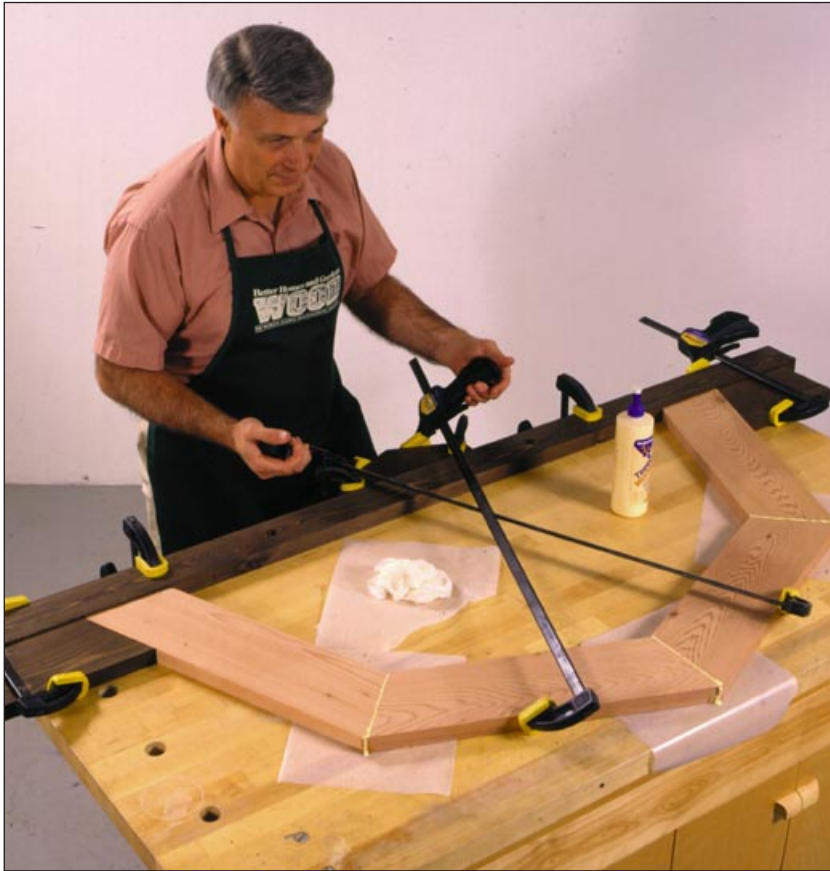

Above: Check the fit, then glue and clamp the arch-top segments together. Long clamps and clamping boards come in handy to pull the joints tight.

Let's begin by with a pair of arches

1 From 1 1/16" stock, cut the arch-top segments (A) and arch uprights (B) to the sizes listed in the Bill of Materials plus 1" in length. (We cut our pieces from 1 1/16"-thick cedar deck boards. If your stock is thicker, you'll need to plane it to 1 1/16" thick to work with a finger-joint router bit. Redwood, mahogany, white oak, or teak would also work well for this project. We also recommend cutting a couple extra arch-top segments. They'll come in handy when testing the finger-joint bit setup in Step 3.)

2 Using the Arch-Top Segment drawing for reference, miter-cut the arch-top segments (A) to length. (We test-cut scrap stock first to verify an accurate 22.5° miter-cut.)

3 Fit your table-mounted router with a finger-joint bit. See the how-to article on this handy bit on *page 7 and 8*. Then, rout finger joints across the miter-cut ends of the arch-top segments and across the top ends of the uprights (B). (We cut 1 1/16"-thick scrap stock first to verify the settings.) Crosscut the uprights to final length.

4 Clamp a board measuring approximately 3/4x4x72" to one edge of your workbench, where shown in *Photo A*. Now, dry-clamp four arch-top segments together in the configuration shown in the drawing *Laying Out the Arch Top on page 5*. (For photo clarity, we stained the boards used to align the segments for clamping.) Check the fit. Remember, if you trim these four segments, you'll need to do the same for the remaining four to keep both arch tops the same exact shape.

Below: After sanding the glued-together finger joints smooth, use a trammel to mark a pair of arcs on one face of each arched top.





8 Clamp a piece of the scrap to the top surface of your bandsaw table. Position and clamp the scrap to the bandsaw table so the bandsaw blade aligns with the inside marked arc on the arch blank, as shown in *Photo D* below.

9 Now, as shown in *Photo E*, slowly feed the blank into the blade, holding the top arched edge against the curved scrap piece. Keep these two pieces flush while cutting the entire bottom edge of the blank. Finally, sand the bottom edge of the blank smooth.

10 Using a pair of sawhorses with extra-long tops, glue and clamp the uprights to the arch tops, as shown in *Photo F*.

11 Sand the arches, and clamp them together surface-to-surface with the edges flush. Mark the hole centerpoints on the arch where dimensioned on the Arch drawing. Drill a $\frac{3}{32}$ " shank hole through both arches and countersink the shank holes on the front side of the front arch and on the back side of the rear arch.

5 Glue and clamp the segments together, as shown in *Photo A*. Place waxed paper between your workbench and the segments at each glue joint to prevent the arch top from being glued to your workbench. Wipe off the excess glue with a damp cloth.

6 After the glue has dried (we used Titebond II and left the arch-top pieces clamped up overnight), sand the joints smooth. Use a trammel to mark two arcs on the clamped-together arch top as dimensioned on the Laying Out the Arch Top drawing and shown in *Photo B*. Repeat the process in steps 4, 5, and 6 to form and mark the second arch top.

7 Bandsaw or jigsaw the arches' top to shape, as shown in *Photo C*. Save at least one section of scrap—you'll use it later. Now, carefully sand to the line with a disc sander or portable belt sander to finish forming the top of the arc.



LAYING OUT THE ARCH TOP

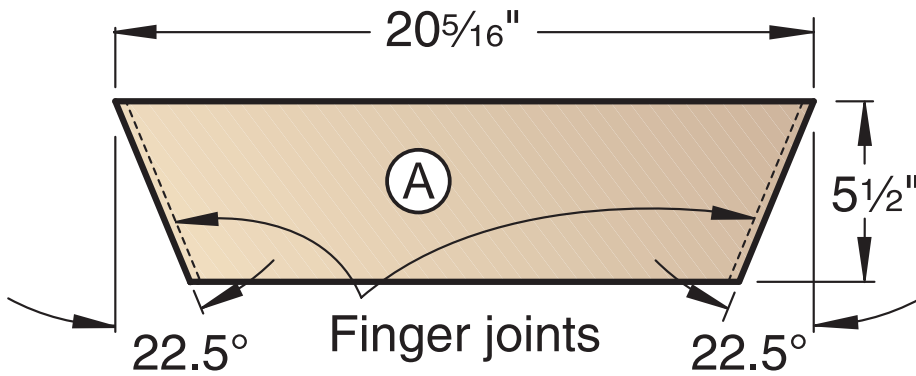
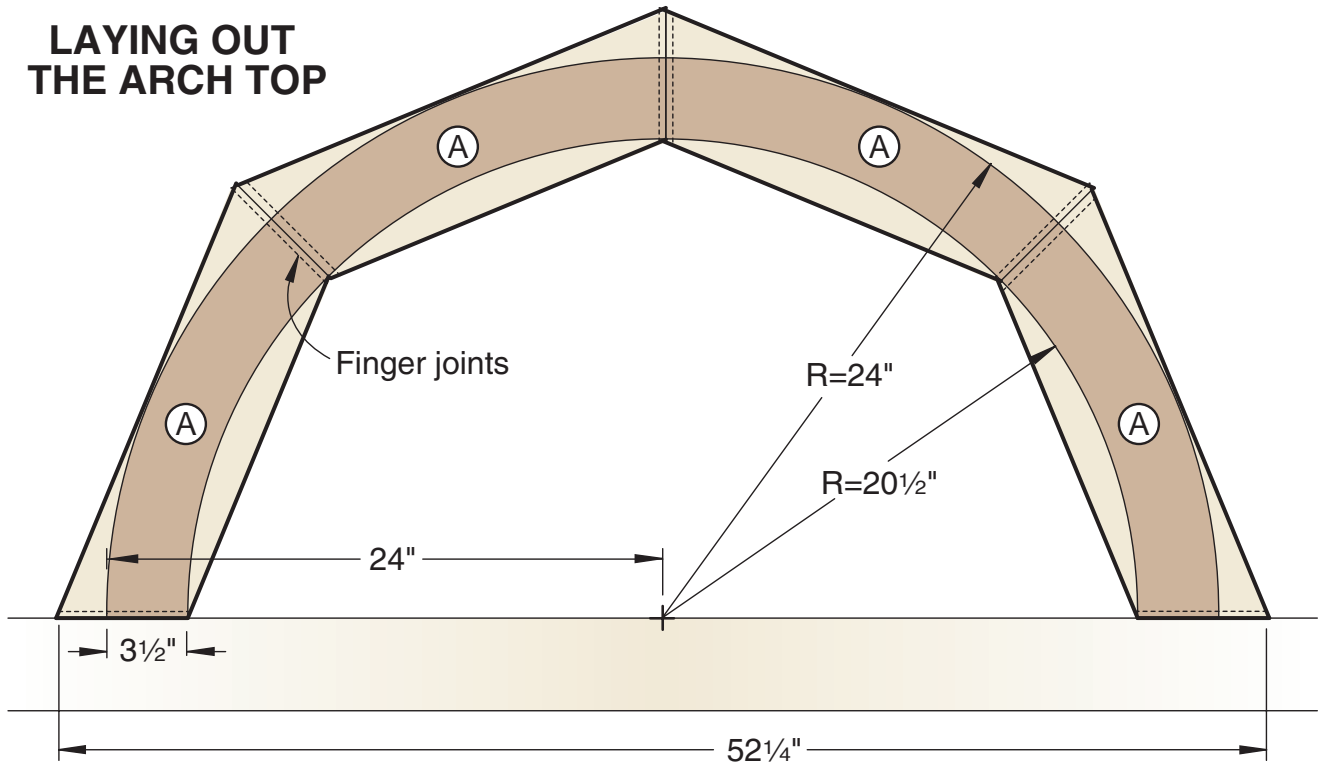

ARCH-TOP SEGMENT

12 Rout a $\frac{1}{8}$ " round-over along all edges (except for the bottom ends) of each arch.

Add the spreaders

1 Cut the spreaders (C, D) and cleats (E) to size.

2 Glue and clamp the cleats (E) to the bottom side of two of the spreaders (D), where shown on the Spreader detail accompanying the Exploded View drawing on *page 2*.

3 Rout $\frac{1}{8}$ " round-overs along all edges of the spreaders and combination spreader/cleats.

4 Mark centerpoints on the ends of each spreader (D). Drill a $\frac{3}{32}$ " pilot hole at each marked point. Using exterior screws (we used stainless steel), screw the spreaders (C, D) between the arches (A, B).

Next, add a contoured seat for comfortable sitting

1 To form the seat supports (F), cut three pieces of 1½" stock to 3½" wide by 22½" long. Then, cut the backrests (G) to the size listed in the Bill of Materials on *page 2*.

2 Transfer the full-size seat support pattern onto the seat supports (F). Cut them to shape. Using the Forming the Seat Backrests and Forming the Seat Supports drawings, machine the supports and backrests to fit in the configuration shown on the Joint detail accompanying the drawings on *page 12*.

3 Glue and clamp the three supports (F, G) together.

4 Cut the front rail (H) and top rail (I) to size. Bevel-rip the front edge of the top rail at 15°. Referring to the Exploded View and Side Section View drawings, rout ¼" round-overs, drill the mounting holes, and screw the rails to the seat supports (F/G) where shown on the Exploded View and Side Section View drawings.

5 Cut the seat slats (J) to size. Rout ⅛" round-overs along the top edges of each. Then, rout a ½" round-over on the slat you'll use across the front of the seat. Drill the mounting holes, and screw the slats to the seat framework (F-I), spacing

them ¼" apart where shown on the Side Section View drawing. (When adding the slats, we started at the top of the backrest pieces and worked down, and started at the front of the seat supports and worked to the back.)

6 Screw the seat assembly in place between the arches.

And, now for the lattice sides

1 Joint one edge of a 2×6, then rip ⅝×1½" strips from the stock for lattice pieces (K, L). Next, rout ⅛" round-overs along all edges of each strip.

2 Use two Ks and two Ls to form the perimeter framework to fit between the uprights (B). Glue and nail these four pieces together. Repeat for the other side of the arbor.

3 Cut a scrap piece of stock 4" wide by about 45" long. Use this as a spacer to position the Ls on the framework when gluing and nailing them in place. Repeat with the Ks.

4 Glue and nail the lattice assemblies to the arbor.

Sand the surfaces, and add the finish

1 Check all surfaces, and sand where necessary.

2 Apply a quality exterior finish to the entire project. (We brushed on Flood CWF-UV Clear Wood Finish. We also placed a small amount of finish in pie tins, and put one under each upright. This allowed the finish to slowly wick into the end-grain upright ends to enhance the rot resistance of the wood.) 🌳

The purchase of these plans does not transfer any copyright or other ownership interest in the plans, the design, or the finished project to the buyer. Buyer may neither reproduce the plans for sale nor offer for sale any copies of the finished project.

Written by Marlen Kemmet
Project Design: Jerry Tedrow
Illustrations: Roxanne LeMoine; Lorna Johnson
Photographs: Dean Tanner; Hetherington Photography
Graphic Design: Lorna Johnson
©Copyright Meredith Corporation 1997

Below: Sawhorses come in handy when gluing and clamping the uprights to the previously assembled arched top.



Finger-joint bits

These bits help you make super-strong joints, but setting one up properly can prove tricky. So, we've come up with a method that ensures your success time after time.

Advantages of and uses for a finger-joint bit

It's usually a simple matter to glue edge or face surfaces together, but gluing boards end-to-end is another matter. That's because the hollow fibers of end grain work like straws to draw adhesive away from a joint. And, the ends of these "straws" provide little surface area for the glue to adhere to. Fortunately, a finger-joint bit solves both of these problems by exposing face grain and greatly increasing the surface area of the joint.

With one of these bits you can make good use of your scrap stock by end-joining short pieces to make longer ones. But, because the edge-grain view of a finger joint can be less than appealing, we suggest you use it only for project pieces that will be painted. Some outdoor projects, such as the garden arbor, look okay with clear-finished finger joints.

A 7-step process for great results

You can buy several types of finger-joint bits, including those with variable-spaced cutters and bearings. For this article we'll show you how to use a no-frills version like the one shown above—a one-piece cutter without a bearing. With this eight-finger bit you can finger-joint stock up to 1¼" thick in one pass.

1 Set the finger-joint bit upright and rotate it so the cutting edge with the highest finger faces you. With a permanent, felt-tip pen, mark the third finger down on the side facing you, as shown in the drawing at right. This will be your reference finger for the following steps.

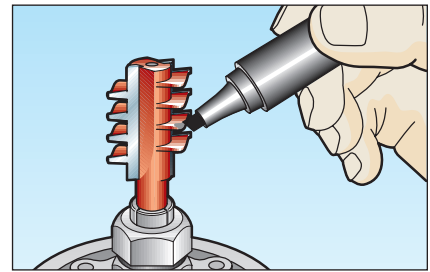

2 Mark a centerline along the edge of a scrap piece of stock of the same thickness as your workpiece. With the bit in your router table, adjust its height so the point of the reference finger aligns with the centerline, as shown at right.

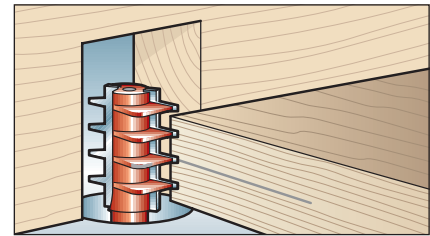

3 With the router unplugged, rotate the bit by hand to the point where it makes the deepest possible cut into the workpiece. Then, use a straightedge to align the fence flush with the innermost cutting edge of the fingers (the "web" of the fingers, so to speak). Also, the fence should be parallel to your router table's miter-gauge slot.

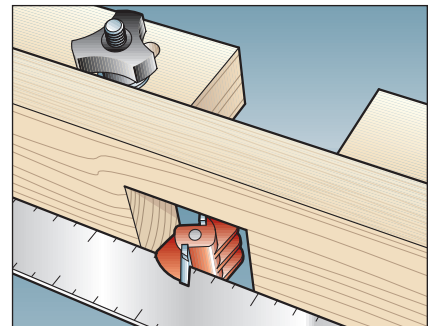

4 Test the fence position by making a test cut into the edge grain of your scrap stock. If the fingers that you just cut into the workpiece do not contact the exit side of the fence, you need to decrease the depth of the cut by bringing the fence forward. If the workpiece fingers contact the fence, but are not smooth and rounded on their ends, you need to increase the cutting depth. Do this by adjusting the fence back.

Cut the edges of two pieces of scrap stock, flip one piece over, and place together the finger-jointed edges. The faces should align flush. If they don't, you will need to adjust the bit's height up or down by ½ of the misalignment between the faces of the scrap stock.

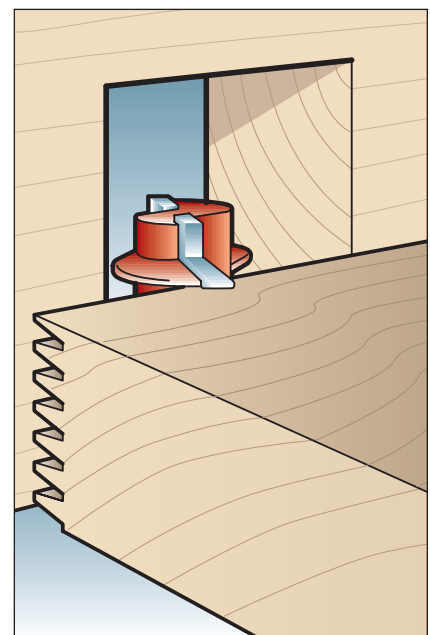

5 Cut the edges of two pieces of scrap stock, flip one piece over, and place together the finger-jointed edges. The faces should align flush. If they don't, you will need to adjust the bit's height up or down by $\frac{1}{2}$ of the misalignment between the faces of the scrap stock.

In the example *right*, the faces are misaligned by about $\frac{1}{16}$ ". So, we *lowered* the bit $\frac{1}{32}$ ". On the other hand, if the piece on the right side of the illustration was too high by $\frac{1}{16}$ ", we would *raise* the bit $\frac{1}{32}$ ".

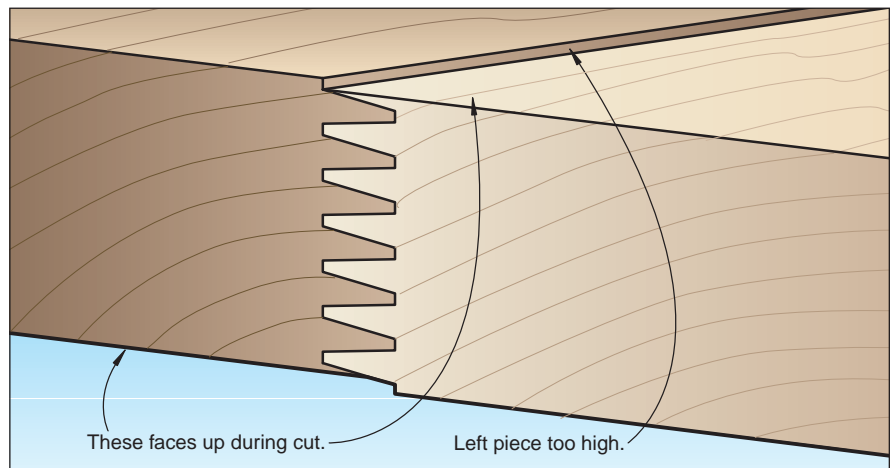

6 Now, you're ready to cut your actual workpieces. First, attach an auxiliary wooden face to your miter gauge. The end of the face should contact the router-table fence without preventing you from pushing the miter gauge smoothly through its complete travel.

Place one edge of a workpiece against the auxiliary face, butt the end of the workpiece against the router-table fence, and make a cut by slowly but steadily pushing the miter gauge forward. (The face side of the workpiece can be up or down.) The auxiliary face backs up the workpiece to prevent edge-grain chipping on the exit end of the cut.

To cut the other end, flip the workpiece *end for end* and repeat the procedure described above. *Do not* simply rotate the piece and keep its same face down for the second cut. By flipping the workpiece, you ensure that the face sides of your workpieces will be on the same side of your completed assembly.

Apply glue to the finger-jointed ends by running a thin bead of woodworker's glue between each finger. Work the glue into the fingers as shown at *left* so it covers all surfaces.

It does not pay to apply glue to both surfaces of a finger joint. This just creates excessive glue squeeze-out.

After applying the glue, join the two workpieces and rub them back and forth to ensure that all surfaces of the joint receive glue.

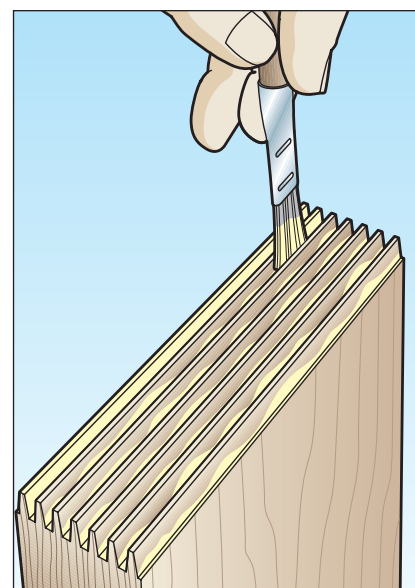
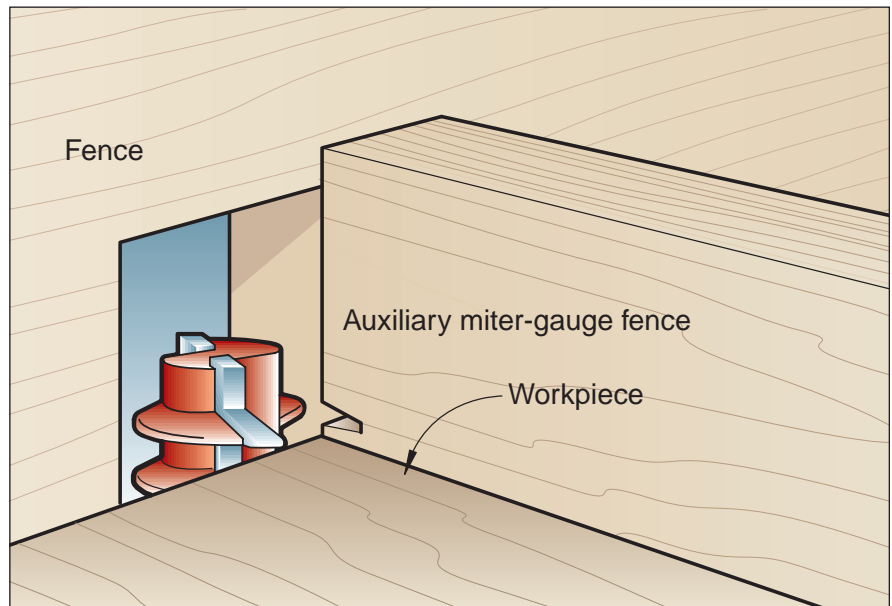

7 Apply glue to the finger-jointed ends by running a thin bead of woodworker's glue between each finger. Work the glue into the fingers, as shown at *left* so it covers all surfaces.

It does not pay to apply glue to both surfaces of a finger joint. This just creates excessive glue squeeze-out.

After applying the glue, join the two workpieces and rub them back and forth to ensure that all surfaces of the joint receive glue.

If your longest clamps aren't long enough for your longest workpieces, or part of your assembly is curved, try the clamping arrangement on [page 6](#).♣

Written by Bill Krier with Chuck I. Hedlund Illustrations: Kim Downing

CUTTING DIAGRAM



1 1/16 x 5 1/2 x 96" Cedar (2 needed)



1 1/16 x 3 1/2 x 96" Cedar (3 needed)



1 1/16 x 3 1/2 x 96" Cedar



1 1/2 x 5 1/2 x 96" Cedar (2x6)

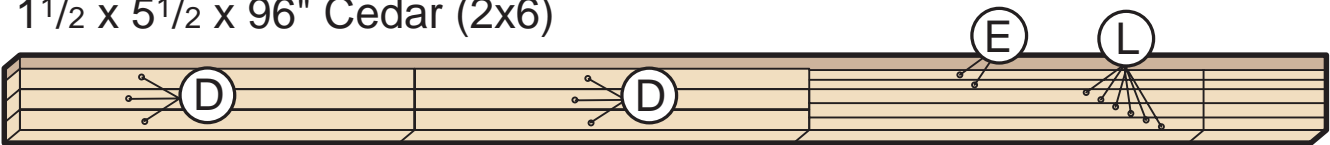

1 1/2 x 5 1/2 x 96" Cedar (2x6)



1 1/16 x 3 1/2 x 96" Cedar



1 1/16 x 3 1/2 x 48" Cedar

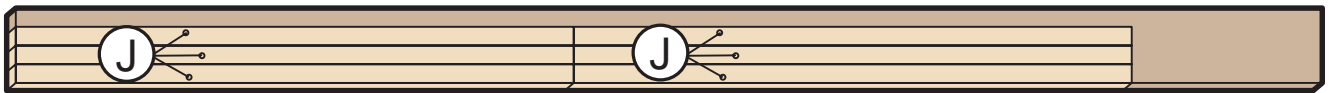

3/4 x 5 1/2 x 96" Cedar (4 needed)

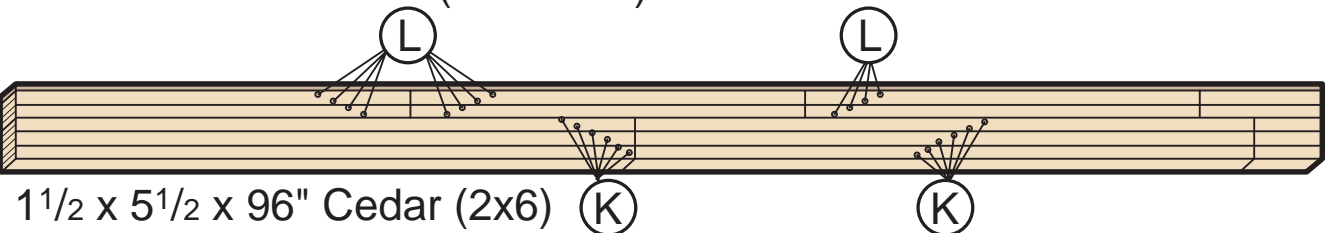

1 1/2 x 5 1/2 x 96" Cedar (2x6)

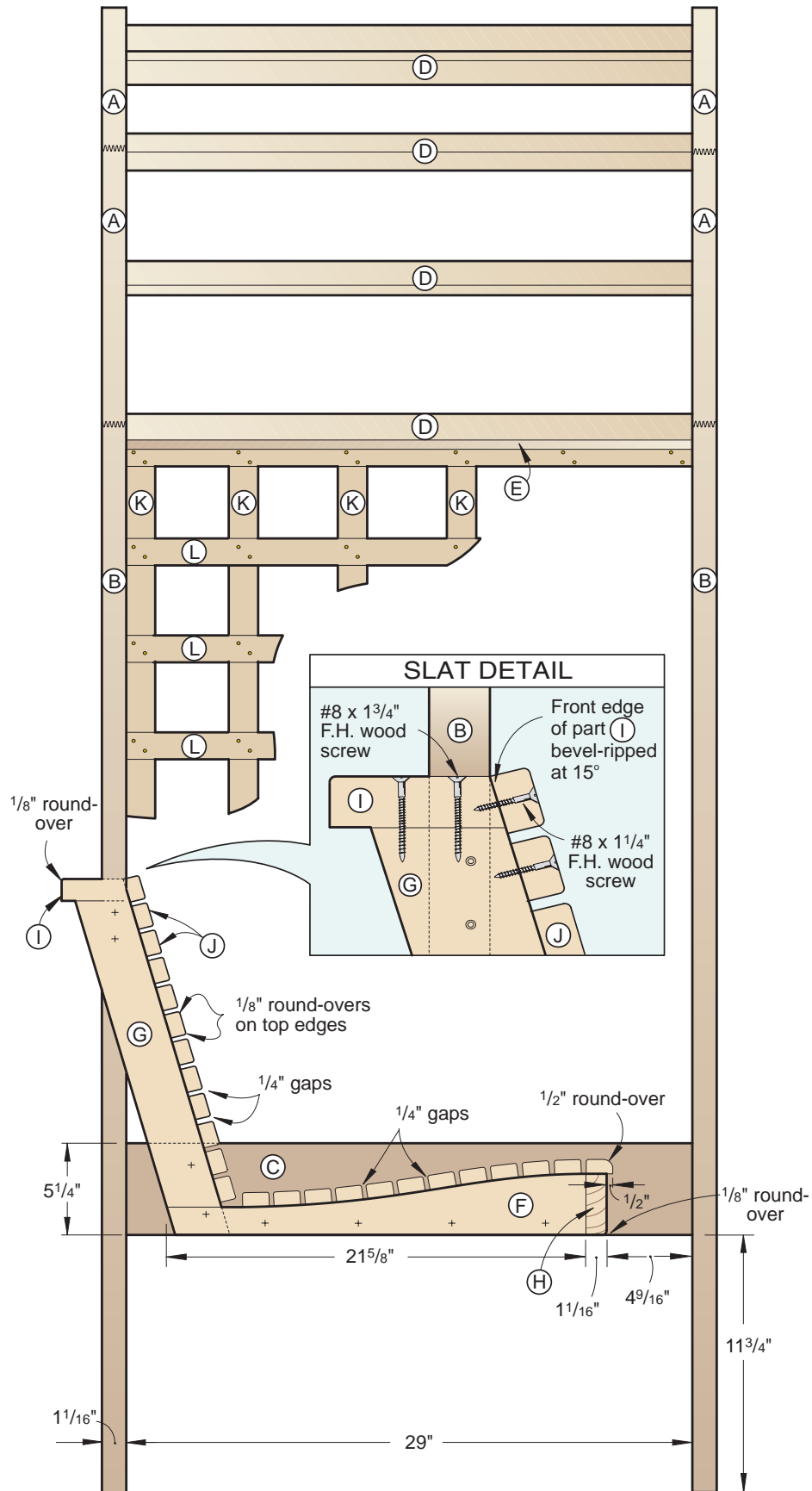

FORMING THE SEAT BACKRESTS

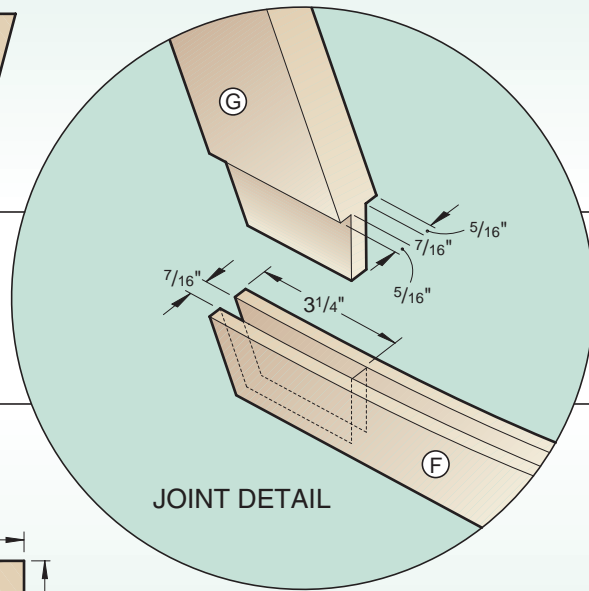
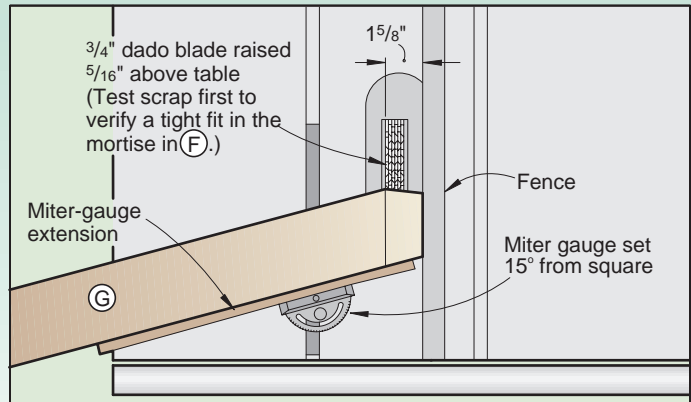
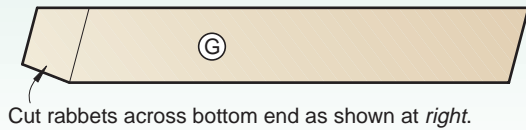
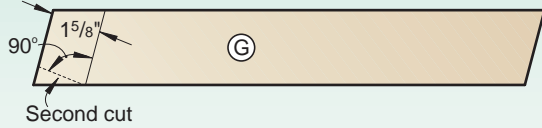
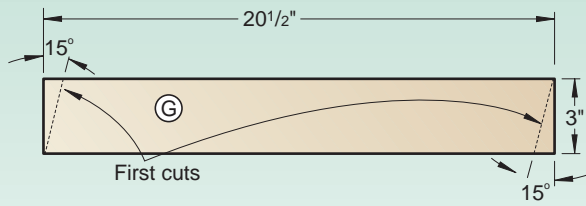

FORMING THE SEAT SUPPORTS

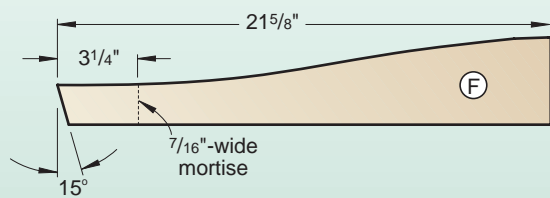
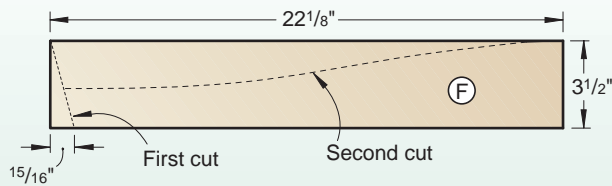

CUTTING THE MORTISE

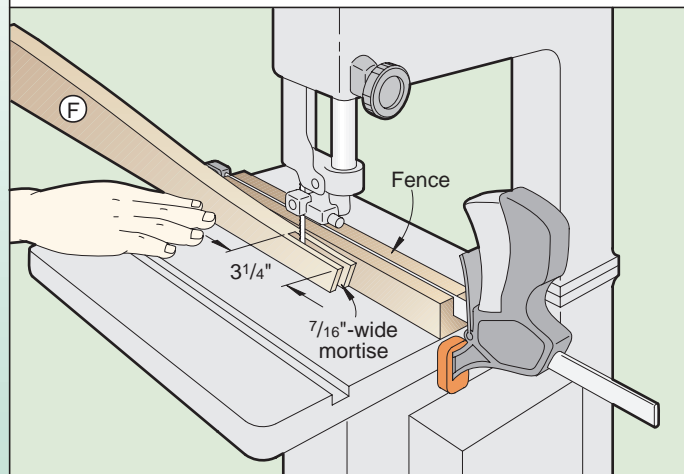

To ensure full-size patterns are correct size, your printer should be set to print at 100% (not fit to page). Measure full-size patterns to verify size.

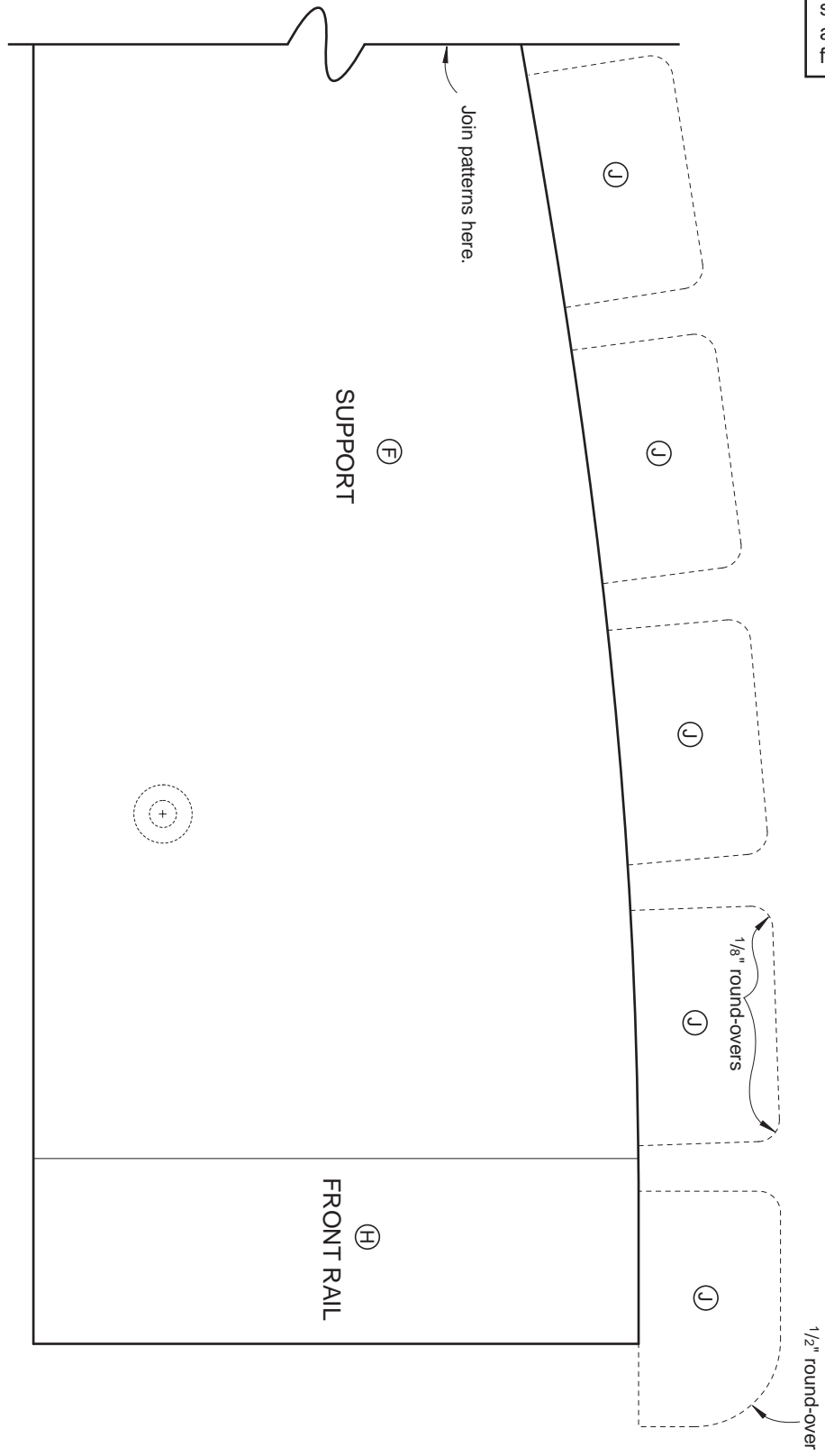
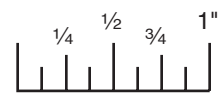

FULL-SIZE PATTERN

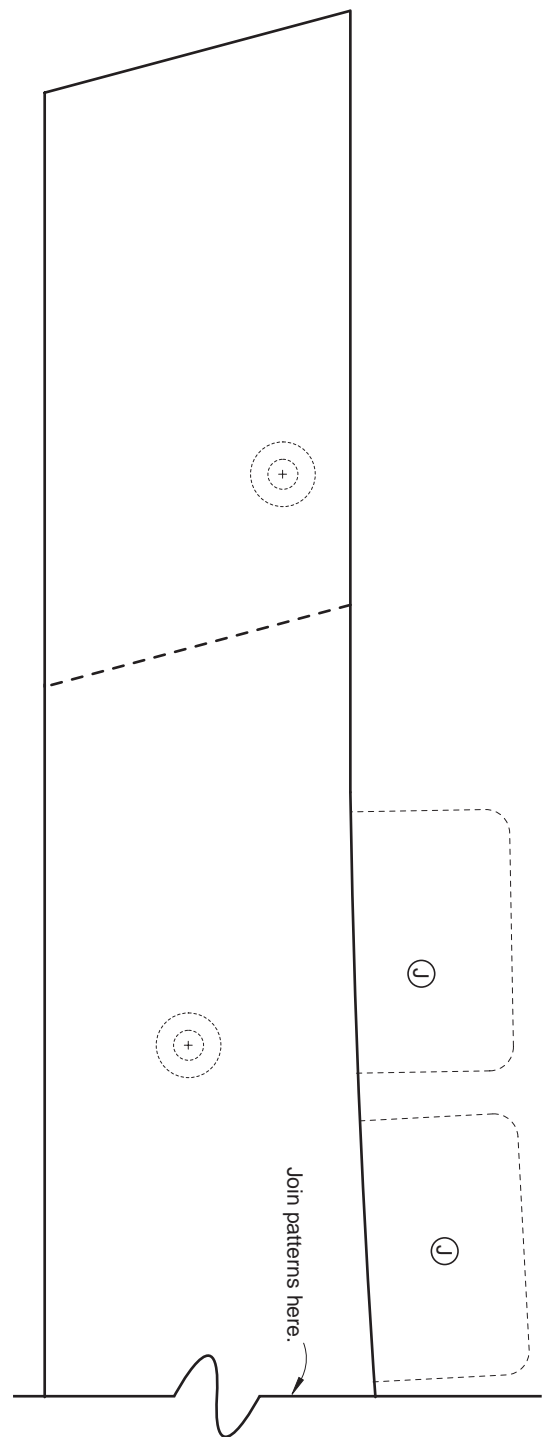
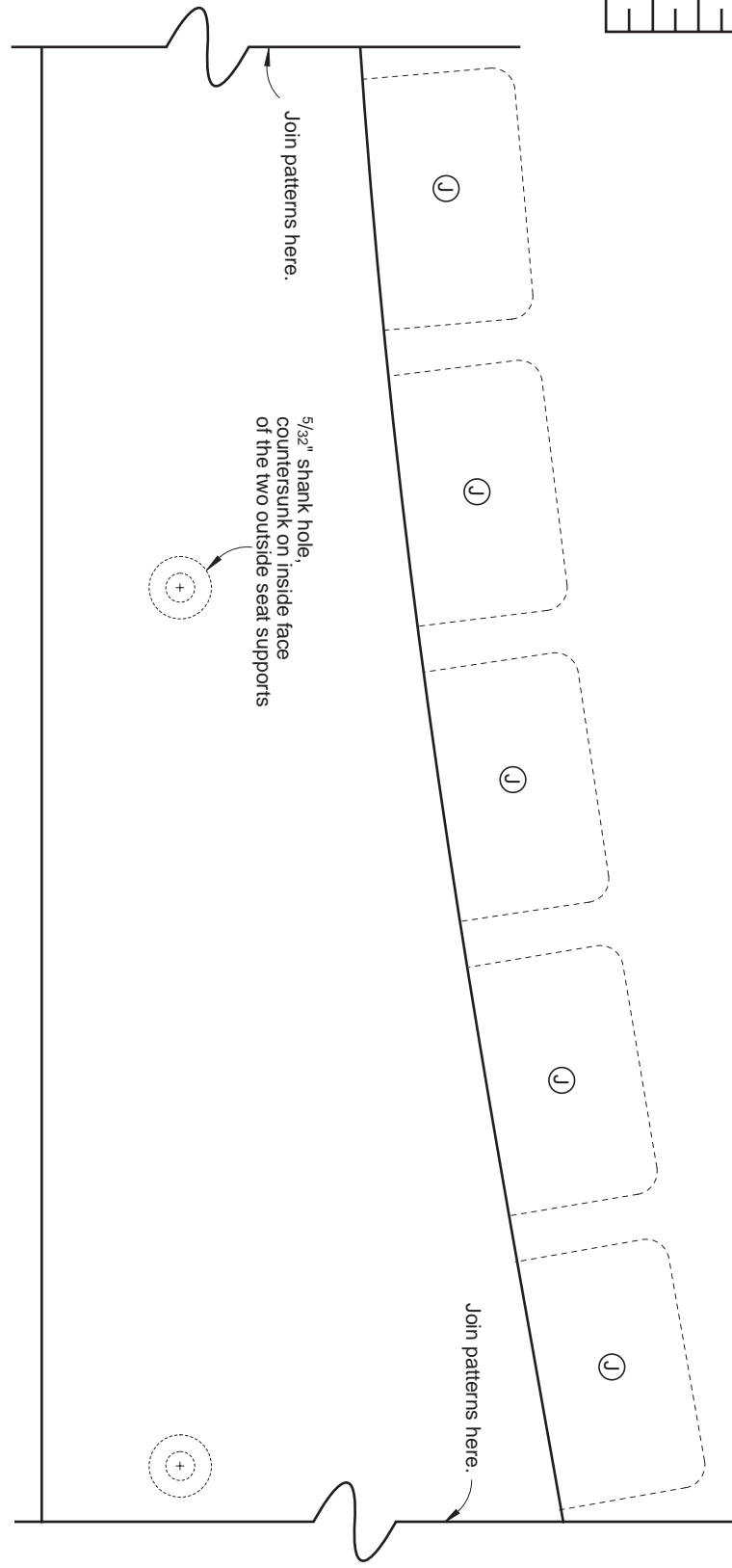
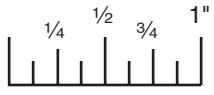

FULL-SIZE PATTERNS

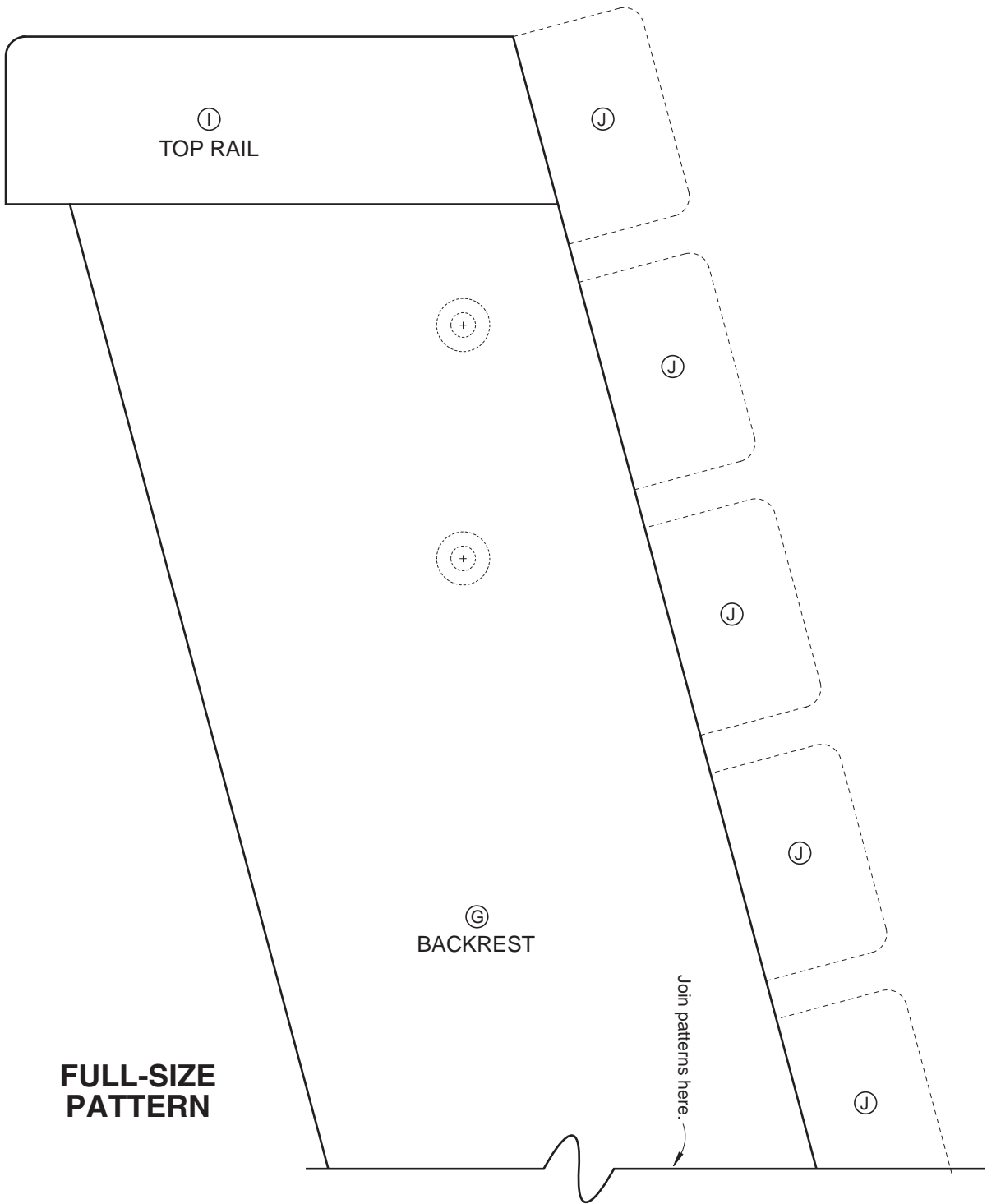
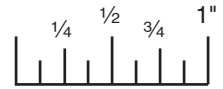

WOODMALL® The Internet's Largest Source for Woodworking Tools and Accessories

<http://www.woodmall.com>

Thanks for your order!

Now that you've got a detailed plan to build that perfect project, visit the WOOD MALL for the internet's largest source for woodworking tools and accessories. The WOOD MALL offers:

- Over two dozen woodworking-related stores
- More than 50,000 tools & accessories
- 24-Hour shopping
- Special sales & closeouts
- Nearly 40 tool comparison charts
- **FREE** monthly woodworking seminar

Visit Today! <http://www.woodmall.com>



Current issue not shown

Like no other magazine, WOOD helps you make the most of your shop time ... takes your skills to the next level. Every issue of WOOD is jam-packed with ...

- Smart tips, tricks, secrets and shortcuts that save you time, effort and money
- Valuable tool reviews with at-a-glance information charts that give you helpful product comparisons
- Giant full-size pattern pull-outs
- Crystal-clear step-by-step instructions, exploded diagrams, finishing secrets and techniques for that professional look – everything you need to bring out your woodworking genius!

- 2 years (14 issues) just \$44 **SAVE \$39.30 off single-copy rate!**
- 1 year (7 issues) just \$26 **SAVE \$15.65 off single-copy rate!**
- Payment Enclosed Bill Me

Fill out information below and mail to: WOOD® Magazine P.O. BOX 37439, Boone, IA. 50037-0439 or Subscribe Online at <http://www.woodmagazine.com/subscribe>

My Name (please print) _____

Address _____ **Apt. #** _____

City _____ **State** _____ **Zip** _____

Canadian Orders: Fill in the form above. Your rate will be 1 year (7 issues) for \$41 – SAVE \$14.65, or 2 years (14 issues) for \$67 – SAVE \$44.30. Prices include postage; 7% GST or 15% HST is added. #12348 2887 RT

U.S. and Canadian subscribers: You also may order by credit card. Call toll free 1-800-374-9663 weekdays from 7 a.m. to 10 p.m. Central Time; Saturdays, 8 a.m. to 3 p.m.; Sundays, 9 a.m. to 3 p.m.

Other International Orders: 2 years for \$89 U.S. or 1 year for \$49 U.S.; prices include postage. To order by credit card call 515/246-6952 during the same hours as listed above (toll charged). Or complete this form; mail with US funds to: WOOD® Magazine, P.O. Box 37439, Boone, IA. 50037-0439 USA.

Your Money-Back Guarantee: You must be satisfied with your subscription or you can get a refund for all unmailed issues.

WOOD® Magazine is published 7 times a year. Savings are based on \$5.95 U.S., \$7.95 Canadian single-copy rate. The first issue mails in 8-12 weeks. Subscription prices subject to change.