



...discover it!

**CMT**  
**CATALOG**  
**2008**

## Power tools & Accessories



Compound miter saw with upper table

14



Hand planer

16



Router CMT2E

17



Industrio™ Routing System

19



Enlock Joining System

21



Universal dovetail jig

22



Ellipse router jig

24



Kitchen worktop jig

25



Hinges boring system

26

## Router bits & Sets



Sets with wooden case

35



Straight bits

50

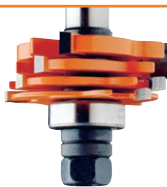

Slot cutters

62



Flush trim bits

64



Chamfer bits

77



Roundover & beading bits

79



Molding bits

89



Raised panel bits

105



Rail & Stile sets

108

## Router bits with replaceable knives



Straight router bits with knives

116



Straight router bits with knives

117



Pattern bits with knives

117



Straight router bits with knives

118

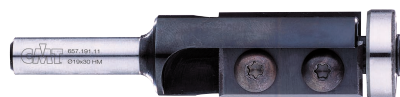

Flush trim bits with knives

119



Chamfer bits with knives

120



Chamfer bits with knives

120



Rabbeting bits with knives

120



Roundover bits with knives

122

# Cutter heads & knives



Rabbeting cutter head 124



Multiradius roundover 128



Professional raised panel 134



Rabbeting cutter head 138



Multiprofile set with limitors 139



Multiprofile set without limitors 140



Knives and limitors 40-50mm 141~149

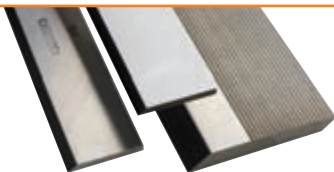

Planer and Jointer knives 151~152



HWM Reversible knives 154~155

# Saw blades



Multi-rip saw blade with/without rakers 160



Saw blade for building contractor 161



Ripping and crosscut 162



Fine cut off saw blade for melamine 164



Scoring 167



Laminated and chipboard 169



Non-ferrous, alu and PVC 171



Ultra industrial thin-kerf "ULTRA ITK" 174



For portable machines 177

# Boring bits



Adaptors 192



Interchangeable boring bits 193



Boring bits 194



Plug cutters 198



Forstner bits 200



Brad point bits 202



Router bits for Domino® 205



Countersinks 207



Dovetail cutters 208

# Router cutters & Chucks



Chucks with precision collets **211**



Precision collets **214**



Solid carbide spiral bits Z3R **220**



Spoilboard surfacing router cutters **225**



DP router cutter with shearr angle **227**



Router cutters **232**



Grooving cutters **235**



Slot and mortise boring bits **236**



Slot mortising bits **238**

# Dowel drills



Adaptors **244**



Drill holders **246**



X-Treme dowel drills **248**



Solid carbide twist drills **253**



Dowel drills **254**



Countersinks for dowel drills **260**



Dowel drills for through holes **263**



Hinge boring bits **264**



Dowel drills with threaded shank **266**

# Display cabinets



Router bits & Saw blades **270**



Router bits **272**



Saw blades **273**



Cutter heads & Knives **276**



Drill & Boring bits **277**



## **SINCE 1962 - MADE IN ITALY THEN, STILL MADE IN ITALY TODAY**

By now, the story has been told. After over 40 years of success and quality in manufacturing woodworking tools - orange woodworking tools, to be precise - word just sort of gets around. We have grown and we have changed, but one thing still remains the same: our commitment to making only the highest quality woodworking tools.



**OUR TOOLS** So, what does it take to make a CMT tool? Like all things of quality, it's not only what you do but how you do it. And anyone who works wood knows that you get out of a piece only what you put into it, and it is no different when manufacturing a tool. You choose your designs and materials carefully and you work using all of your skill and know-how. You'll be happy to know that's what we do at CMT too.

**DESIGN** - Everything starts with a clear idea and having the potential to express it. We have both. At CMT, our technical department uses the best of both worlds - computer technology and hands-on experience - to engineer and design each tool so that it performs flawlessly each time you use it, and to guarantee that you'll be using it for a long, long time.

**MATERIALS** - Turning a design into a finished product means finding the right material that will do the job and that live up to the specifications set out in the design - quality performance from the final product depends on it. When it comes to selecting raw materials, we don't cut corners. At CMT, we know that high quality tools come only from high quality raw materials, so we use only solid bar stock steel and specially formulated micrograin carbide to manufacture our bits and blades.

**MANUFACTURING** - Like we said, it's not just what you do but how you do it. Over the years we have continuously invested in the latest technology in CNC machining equipment and innovative software to manufacture our tools. The result is that now our entire manufacturing process, from turning and milling the steel shanks to brazing and sharpening the carbide cutting tips, is completely automated. And since a machine is only as intelligent at the person using it, everything is operated by specifically trained operators.

**THE FINAL TOUCH** - A tool simply wouldn't be a CMT tool if it didn't have the trademark orange color non-stick PTFE coating on it. This unique industrial-strength surface coating is designed to withstand the physical stresses the tool undergoes during use while protecting it from residue build-up and burning. And we really like the orange color too.

**CMT ORANGE TOOLS.** Manufacturers of high quality woodworking tools since 1962, we are still proud to put "Made in Italy" on all our orange tools.

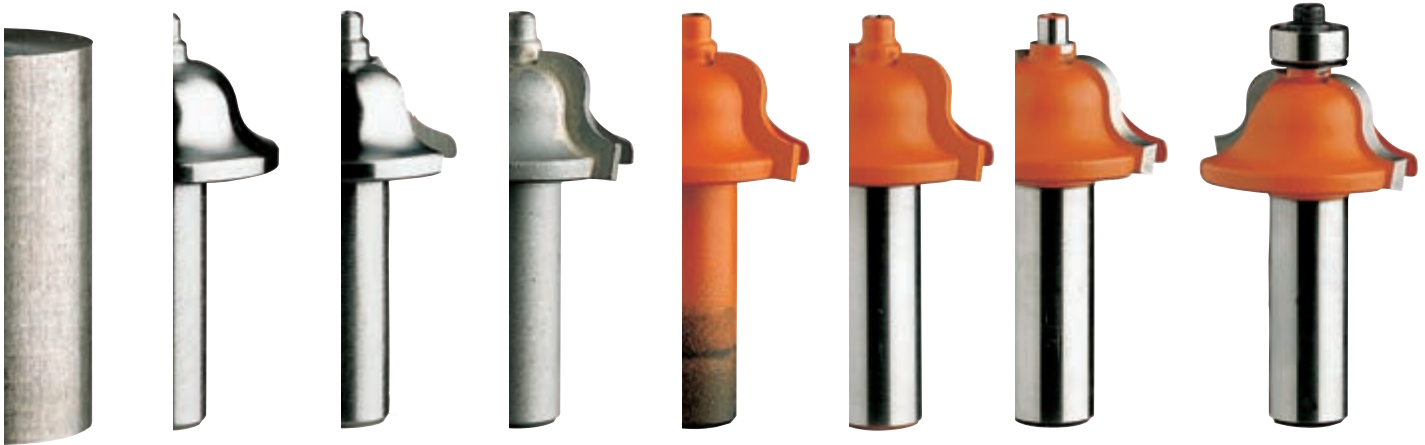

**QUALITY CONTROL** - Nobody's perfect, but we're trying. CMT uses rigorous quality control programs and equipment to ensure that each bit has been manufactured with precision and accuracy and that it will give the long-lasting performance you expect from a CMT orange tool. CMT is in the process of adopting the directives set out in ISO 9001 which will give SPC quality control by an independent party under the Common Market Directives ISO 9001. Quality control is the final step of the production process, but it's just as important as the first.

**WE RECYCLE** - The water used during production must be pure and free from contaminants or hard minerals like iron or calcium which can build up and damage the machinery. CMT filters and purifies its water using a reverse osmosis system located inside the plant. Also the oil used in grinding and machining our tools must be clean and absolutely free of contaminants. Clean oil, after enough use, gets dirty, so we filter and reprocess dirty oil on the premises. This is our way of guaranteeing the quality of the oil we use, as well as contributing to help protect the environment.

**OUR TRADEMARK COLOR ORANGE** - As the story goes, we began small. We also put orange color surface coating on our tools, then we put our tools on the market and soon our orange tools were all over the world. Now, any woodworker anywhere in the world can tell you that orange tools means CMT, and that CMT means quality. Here at CMT we know we produce quality. You should too. That's why we have trademarked the color orange on woodworking tools - it's your guarantee that you are getting a genuine high-quality CMT product.



Fully automated assembly and marking.



Loading the automated multi-axis CNC sharpening machines.

## BUILDING THE WORLD'S FINEST CUTTING TOOLS

We built our foundations - and our reputation for high quality - on the craftsman-like manufacture of boring bits and router bits. Times have changed and technology has completely altered the way things are done, and in this regard CMT is no exception. Our facilities have been newly renovated and our equipment today represents the most advanced technology available on the market, but we still make and will continue to make routers and boring bits with all the skill and care that we always have.



**DESIGN** - We engineer each tool with its purpose in mind. Years of developing high performance tools means that many of our top-selling tools are tried and true, the result of continuously perfecting each design, but we don't stop there. New materials, new profiles and new methods of working keep emerging. At CMT, we want to stay on the cutting edge of what's new in the industry so our technical department constantly evaluates current market developments and, by using state of the art software and years of experience, designs tools that are worthy of the CMT mark.

**MATERIALS** - Essentially, the main components of a router bit are just two: steel and carbide. If either of these is less than the best, the tool we make will show it. We've researched steel and carbide since the beginning, and found exactly what we were looking for:

### ► Superior steel

All our steel comes from right above the border, in Switzerland, where they use an exclusive hot drawing process to forge the solid bar stock we use to manufacture our router bit shanks and bodies. The result is steel that is superior in strength and exceptionally resistant to fatigue and abrasion.

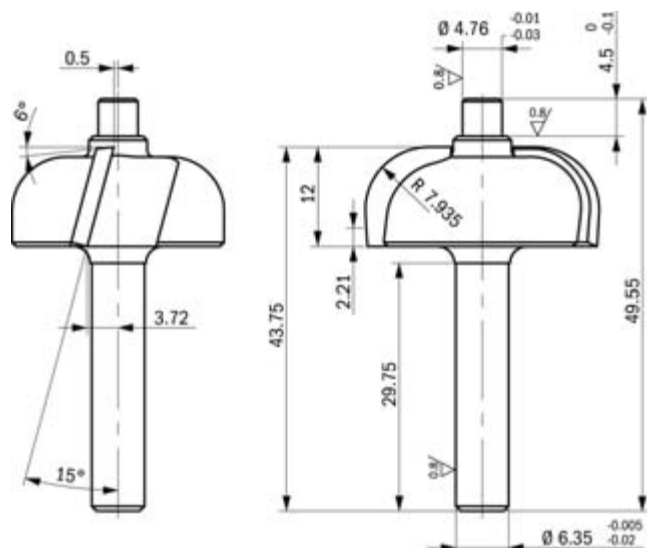



## ► High-grade tungsten carbide

If steel is what gives our tools strength, carbide is what gives them intelligence. The capacity of the carbide tip to cut precisely and to last a long time is critical for the performance of any tool, so at CMT we use only premium micrograin carbide from Luxembourg to make the tips for our router bits.

## MANUFACTURING

► **Turning, Milling and Cutting** Our biggest investment in recent years has been in upgrading production. Today, all machinery at CMT is fully automated. CNC machines run by specially trained operators make sure that the shanks and bodies of our router bits and boring bits are accurate and perfectly balanced.



► **Heat forged steel bodies for large diameter bits** No router bits are exactly the same, sometimes not even in the way they are made. Certain bits require a few more steps than others, like heat forging the steel of larger diameter bits before turning it down into precise bit bodies. This extra step produces a radial grain orientation which gives large diameter bits extra strength and durability.

► **Brazing** We have pioneered the art of brazing. Not only does our unique custom-designed computerized brazing equipment help eliminate the inconsistencies found in old fashioned hand brazing, but our silver-copper-silver brazing 'sandwich' provides a tight bond between the steel and the carbide, with a shock absorbing effect to protect the carbide tips when cutting harder woods.

► **Specially formulated carbide for specific applications** You have to cut every kind of material, so we make sure that our carbide tips can handle each individual job. This means specially formulating the carbide of each tool so that the compositions vary from being super hard (for tough cutting jobs like laminates) to being less hard (to absorb the impact when cutting large profiles) and everything in between.

► **Grinding and Sharpening** The final step in the production process is no different from the rest: sharpening and grinding are done to extreme precision on multi-axis CNC machines. Each bevel and angle is ground or sharpened to the micron, to produce a cutting edge that is both razor sharp yet extremely durable.



680°C in seconds - and the brazing is complete.

**QUALITY CONTROL** - In even the most carefully done task, there's always room for error. However at CMT, we take measures to prevent even this. Just like we have always done, we manually check the quality of our tools at each step of the manufacturing process, and we still make test cuts with rail & stile bits to make sure the cut fits. However, now we also use a fully automatic measuring process that measures every dimension of the tool without actually coming into contact with it, to make sure that the tool measurements are accurate and that the profiles conform precisely to technical specifications. We also use this system to gauge the wear and tear on the CNC machines.



CMT's fully automatic measuring system.



## HOW WE PRODUCE OUR HIGH QUALITY BLADES

CMT stands for quality, which means we put quality into everything we do. It only makes sense. At CMT we figure that if our router bits are going to be top quality, high-performance and orange, then our saw blades should be too. And to do that, we simply follow the same guidelines for our blades that we do for our bits: start with a solid design, use only the best materials and manufacture with skill and care. And of course, make sure they are trademark orange.



**DESIGN** - The simplicity of a circular saw blade design is in reality a complexity of technical considerations. Each blade has to make a certain type of cut, and this requires careful analysis of hook and grind angles, gullet designs, to location of sound dampening slots and the thickness of the blade - just to name a few. So in order for us to get the best design for our blades - and for you to get the best performance from them - we use the same method that we use to engineer our router bits: we combine the knowledgeable minds and experience of our technical department and the latest computer technology. The result is a superior blade that has some rather special "standard" features:

**Anti-vibration design** - The anti-vibration cuts in the blade do exactly what their name implies: they are the anti in anti-vibration. This translates into less chattering during cutting and consequently it lengthens the life of the blade. Anti-vibration also means a flawless cut, so stabilizers and scoring blades are no longer necessary.

**Expansion slots** - These little hook-shaped cuts in the blade help to reduce noise while regulating the expansion and contraction of the blade as it generates heat during cutting operations.

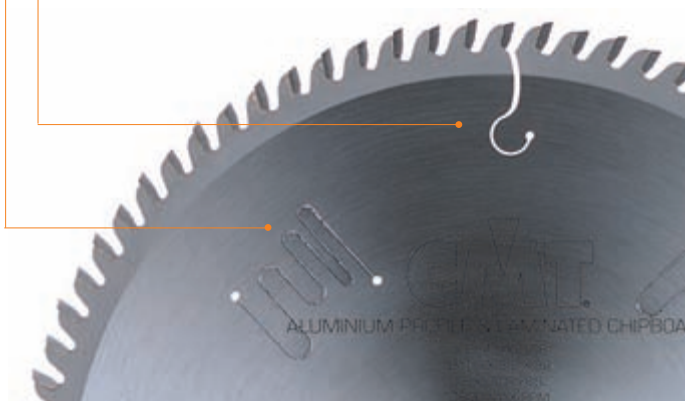

**MATERIALS** - When it comes down to it, saw blades are much like router bits - it's just two components: steel and carbide. So in selecting the raw materials, we are every bit as picky with our saw blades as we are with our router bits. Besides, why mess with a winning formula like superior steel and tungsten carbide?

► **Steel** - It's the heart of the blade, so CMT uses only the finest steel available: super 42-44 Rockwell hardness steel.

► **Carbide** - The cutting tips of every CMT blade are made from the best grades of micrograin carbide.



Laser cutting the steel plates.

**MANUFACTURING** - CMT saw blades are machined on automated CNC machines, from start to finish. The advanced technology and precision of these machines ensures uniform quality on every blade while giving us the possibility to carry out more efficient quality controls.

► **Laser cutting** - The steel plate of the blade is laser cut, NEVER die cut, from superior strength steel. This way of cutting steel is not only extremely precise but it makes it possible to cut harder strengths of steel and does not stress the plate while cutting, so the resulting blade is flat and true and more resistant to warping.

► **Grinding and tensioning** - After it has been cut, the blade is polished and tensioned, the evidence of which can be seen in the superior finish and a tension ring that are visible on the blade. Then the central bore is ground to a smooth finish so that the blade will fit precisely on the saw arbor and will have perfect concentricity during rotation. The seats for the carbide teeth are also ground, making sure that the carbide tips fit perfectly, providing the right conditions for making a secure braze.



Grinding and tensioning the blades.

► **Silver-copper-silver sandwich brazing** - Once again, experience has been a good teacher. Automated brazing with a special silver-copper-silver "sandwich" brazing compound yields excellent results and reduces the chances of failed welds. In addition, this combination of metals is critical during brazing because as the steel body and the carbide tipped teeth are heated and cooled, they expand and contract at different rates. The copper layer acts as a buffer and keeps the carbide from cracking during cool down shrinkage. When wood-working, the copper provides flexibility and resistance to impact which in turn protects the carbide tips and steel shoulders when cutting through harder substances or knots in the wood.

► **Specially formulated carbide tips** - What is true for router bit carbide tips is also true for the carbide tips on saw blades: what's good for one type of blade may not be good for another. At CMT, we have studied carbide formulas and their impact on blade performance and have developed specially formulated carbide tips to match each blade's application. Larger blades require an extra-fine harder carbide that holds its edge and resharpenes easily, while smaller blades need a special carbide that can withstand the occasional nail or imperfections that often occur in construction work. For each blade and each use, there is carbide made especially for it.

► **Sharpening and laser marking** - The final step is sharpening the micrograin carbide teeth. During the sharpening phase, each angle is ground to razor-sharp precision - down to the Milacron - on multi-axis CNC machines. We also laser mark our blades so you have all the details about the blade type and its uses, right there on the blade.

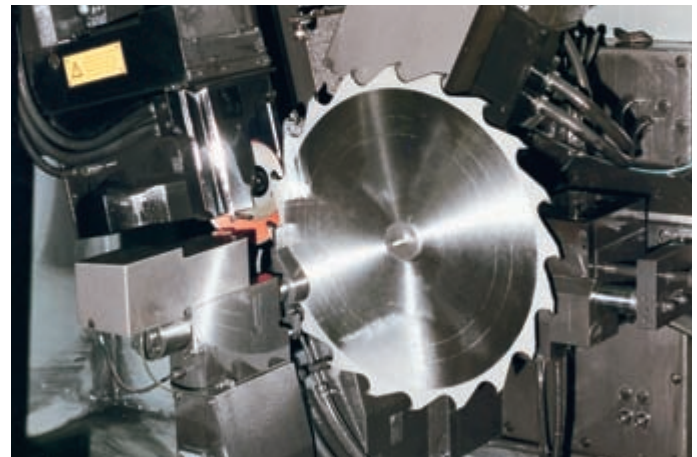

Sharpening the carbide tips.

► **Packaging and instructions** - CMT blades are packed and protected for shipping, display and storage in either a sturdy cardboard box or in a patented heavy duty HDPE plastic case that's as durable as our tools. Illustrated instructions for resharpening are included with your CMT blade so that you have all the details you need to keep the blade sharp, which will also help you extend the life of the blade.



**CMT ORANGE TOOLS.** Manufacturers of high quality woodworking tools since 1962, we are still proud to put "Made in Italy" on all our orange tools.



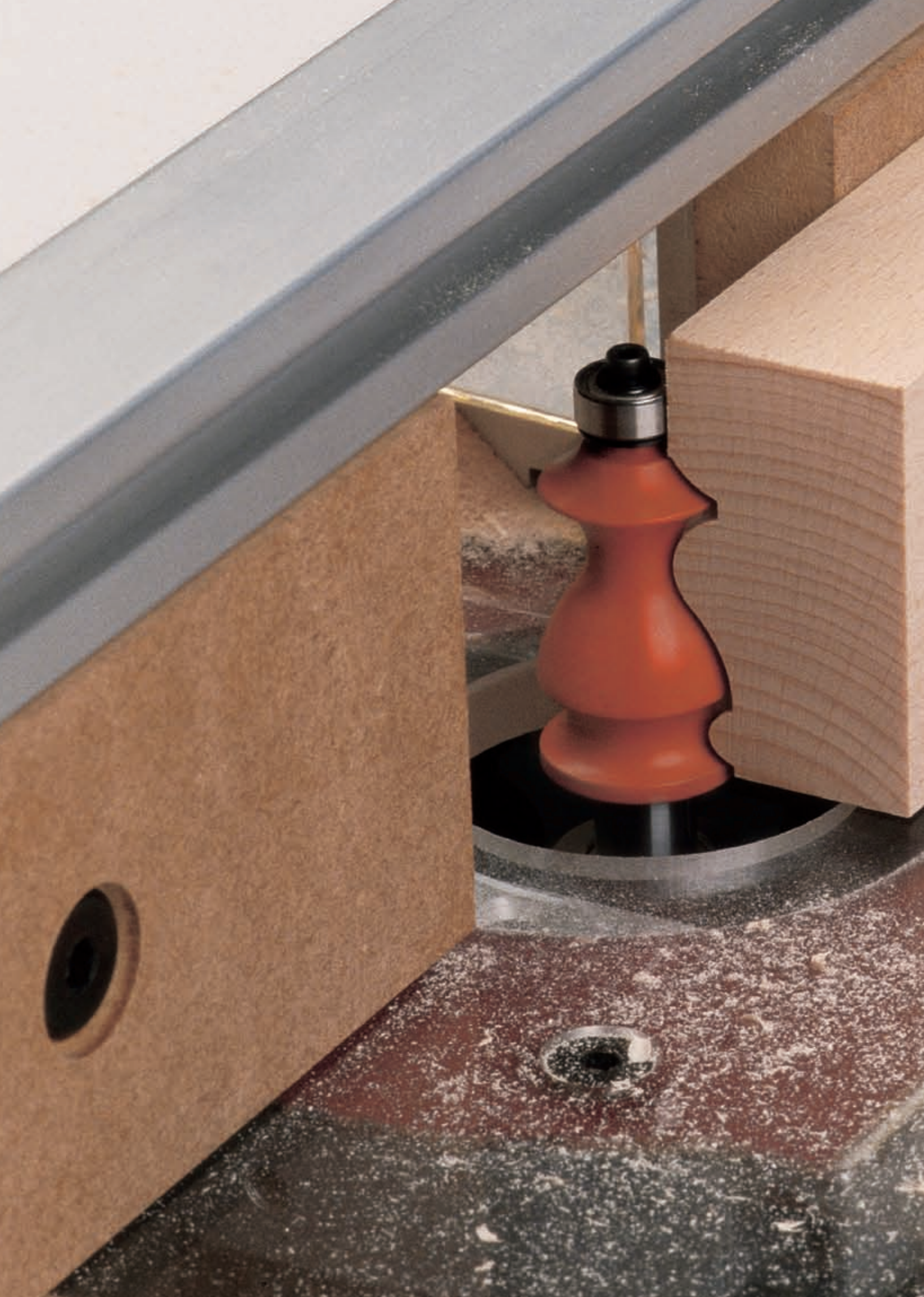



# Power tools & Accessories



Compound miter saw with upper table 14



Hand planer 16



Router CMT2E 17



Industrio™ Routing System 19



Enlock Joining System 21



Universal dovetail jig 22



Ellipse router jig 24



Kitchen worktop jig 25



Hinges boring system 26

# Router bits & Sets



Sets with wooden case 35



Straight bits 50



Slot cutters 62



Flush trim bits 64



Chamfer bits 77



Roundover & beading bits 79



Molding bits 89



Raised panel bits 105



Rail & Stile sets 108



- ALWAYS** thoroughly check all tools for possible flaws before using.
- ALWAYS** wear safety glasses and ear protection.
- ALWAYS** thoroughly read the owners manual and manufacturer instructions before using.
- ALWAYS** check that at least 75% of the shank is securely inserted into the collet of the router.
- ALWAYS** use template guide collars when possible to absorb lateral bit deflection.
- ALWAYS** use a fence when working on the router table.
- ALWAYS** reduce the router speed when working with larger diameter bits.
- ALWAYS** keep your fence adjusted so there is some clearance between the bearing guide and the workpiece.
- ALWAYS** take care to remove large quantities of stock (cross section > 10mm) in more than one run.
- ALWAYS** keep your tools sharpened, clean and stored in a safe place to avoid breakage and accidents and to extend the life of your bits and blades.
- NEVER** use dull or defective, even suspiciously defective, tools.
- NEVER** force the shank entirely into the collet (bottoming out). Leave about a 3,2mm (1/8") space from the bottom.
- NEVER** force the bit into your router or overload the router.

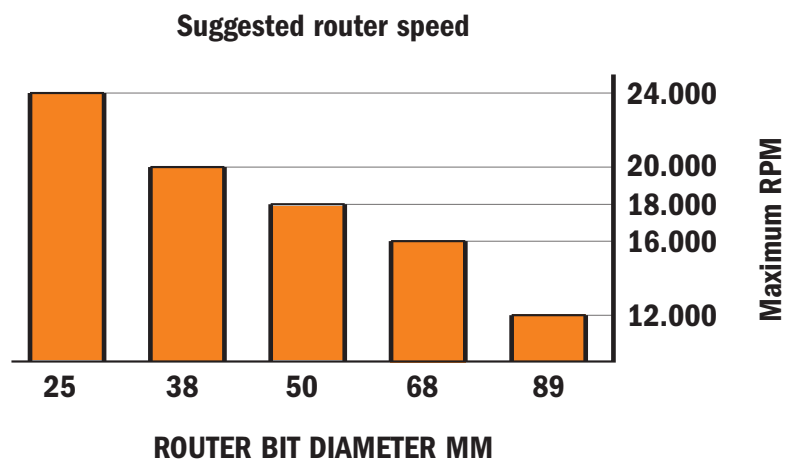

- Ø** = Diameter
- A** = Cutting angle
- C** = Bearing diameter
- D** = Cutting diameter
- d** = Small cutting diameter
- H** = Cutting depth
- I** = Cutting length... cutting height
- I<sub>1</sub>** = Drilling depth
- Inches** = Inches
- L** = Overall length
- LB** = Adjusting length
- LH** = Left-hand rotation
- mm** = Millimeters
- PTFE** = Non-stick industrial coating, black and orange
- R** = Radius
- RH** = Right-hand rotation
- RPM** = Round per minute
- S** = Shank diameter
- T** = Maximum joint thickness
- Z** = Number of teeth

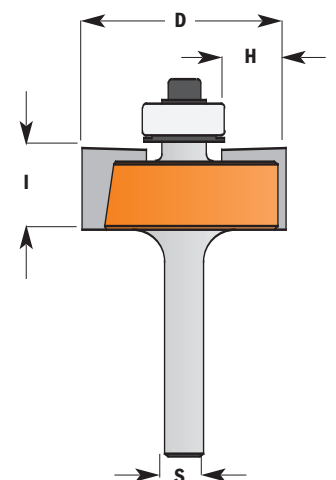
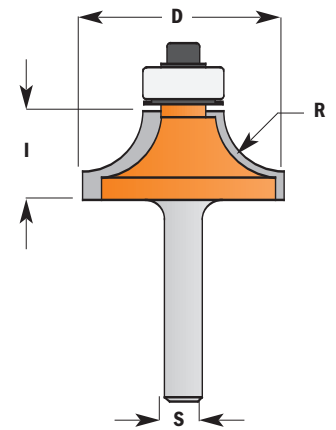
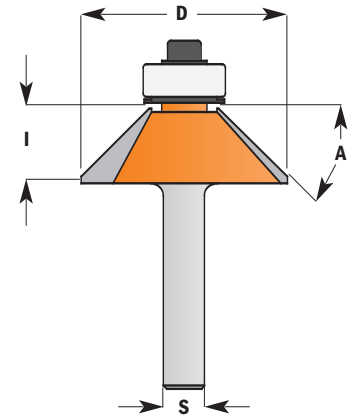
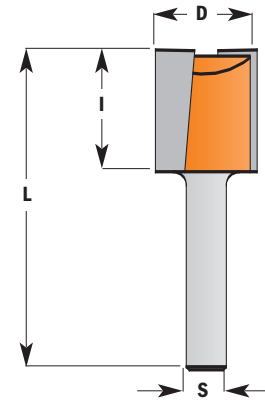

Tungsten carbide tipped



Tool with plunging capacity



Solid tungsten carbide



Not for hand held use for router tables only



High speed steel



Bearing diameter



Alloyed tool steel



One HW cutting edge



High-alloyed tool steel



One HW cutting edge + one HW plunging cutting edge



Anti-kickback



Two HW cutting edges



Radial relief



Two HW cutting edge + one HW plunging cutting edge

THE IDEAL MITER SAW FOR THE PROFESSIONAL WOODWORKER

**MADE IN ITALY**  
**CMT4**

**EASY & QUICK SAW  
BLADE REPLACEMENT!!**

**INCREASED CONTROL**

a steady cutting speed is insured by the comfort grip handle located in central position

**SHARP ACCURACY**

thanks to the reinforced and rectified high-pressure, die-cast aluminium upper table

**EASY-ACCESS, ANTI-DUST  
ON/OFF SWITCH**

**EASY SETTING OF THE  
ROTARY TABLE**

with preset stops in the most common positions

**MAXIMUM STABILITY**

delivered by 6 sturdy support feet

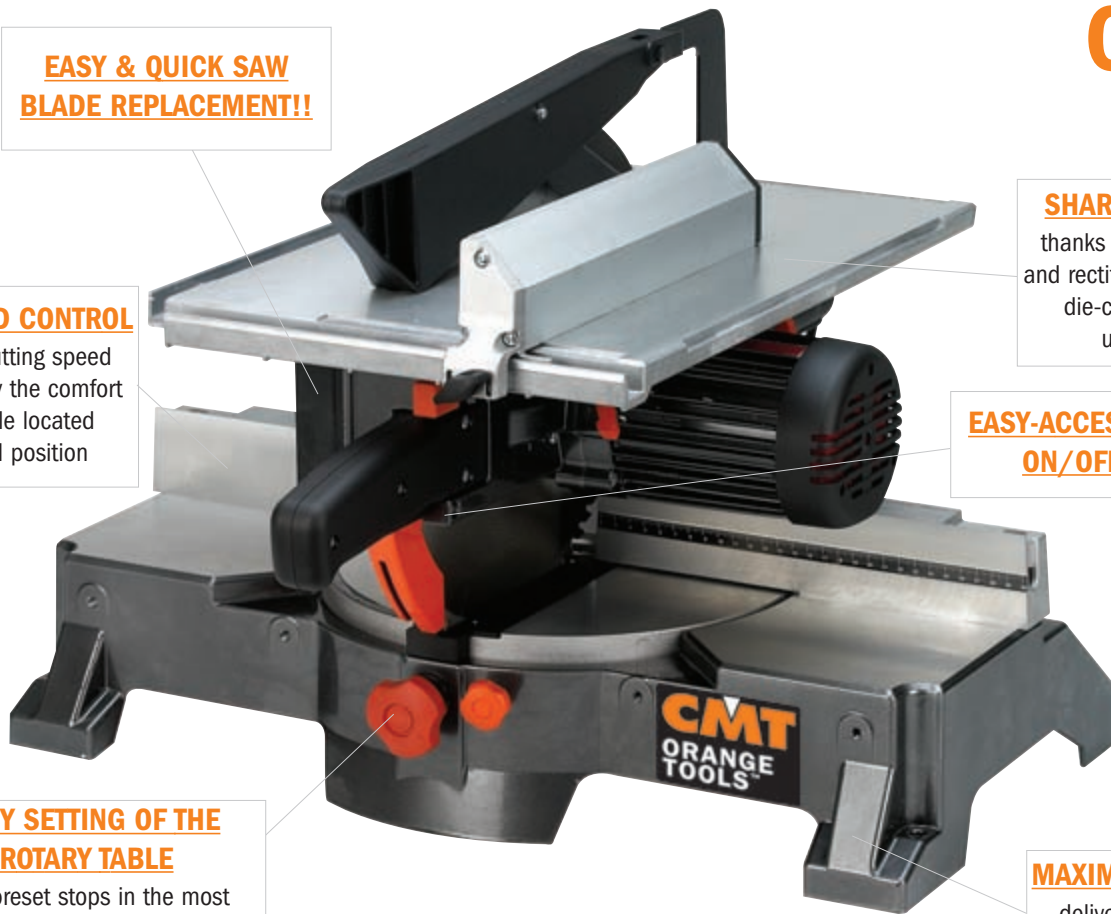

**MAXIMUM CUTTING CAPACITY**

<p><b>Upper table</b> Max.height 67mm</p>	<p><b>90°+90°</b> 0° 170x78,5(h) mm Max.height 25x105(h) mm</p>	<p><b>45°+90°</b> 45° 116x78,5(h) mm</p>	<p><b>90°+45°</b> 45° 170x62,5(h) mm</p>	<p><b>45°+45°</b> 45°+45° 92x62,5(h) mm</p>
---	---	--	--	---

**Technical Features and Specifications**

- High power, low-noise, asynchronous induction motor
- Circular saw blade guard
- Cutting capacity .....15° - 22,5° - 30° - 45°
- Horsepower .....1.200 Watt
- No Load Speed .....3.000 RPM
- Circular saw blade .....Ø 305mm - Bore=30mm
- Upper table dim. ....305x474mm
- Weight .....23,5 Kg

**Standard Equipment**

- Length stop - to make repetitive cuts of the same length
- Upper table fence for high precision cuts
- Dust extraction outlet
- Wrenches
- 1 HW circular saw blade, Ø305mm, Z54
- 1 year warranty
- Instruction manual

**Worldwide technical assistance**

DESCRIPTION	ORDER NO.
Compound miter saw 305mm with upper table	<b>CMT4</b>

**Suitable saw blades:**

<b>293.028.22M</b>	Ripping saw blade Ø305mm - Z28 ATB
<b>294.054.22M</b>	Ripping and crosscut saw blades Ø305mm - Z54 ATB
<b>285.072.22M</b>	Fine finishing saw blades Ø305mm - Z72 ATB
<b>297.096.13M</b>	Non-Ferrous metal and laminated panels saw blades Ø305mm - Z96 TCG

THE IDEAL MITER SAW FOR THE PROFESSIONAL WOODWORKER

**MADE IN ITALY**  
**CMT5**

**ERGONOMIC HANDLE**  
for the maximum confort and control

**BELT DRIVEN**  
induction motor offers excellent performance and noiseless

**FINE DEPTH ADJUSTMENT**  
of the upper table for precision cuts

**REINFORCED**  
motor head support for stability

**4500 RPM**  
allow higher cutting speed and best finishing

**REMOVABLE FENCE**  
for easy set up of the angular cuts

**EASY SETTING OF THE ROTARY TABLE**  
with preset stops in the most common positions



**MAXIMUM CUTTING CAPACITY**

**Upper table**  
Max.height 40mm

**90°+90°**  
0° 150x73(h) mm  
Max.height 50x108(h) mm

**45°+90°**  
45° 90x73(h) mm

**90°+45°**  
45° 150x46(h) mm

**45°+45°**  
45°+45° 48x45(h) mm

**Technical Features and Specifications**

- High power, low-noise, asynchronous induction motor
- Circular saw blade guard
- Cutting capacity .....15° - 22,5° - 30° - 45°
- Horsepower .....1.200 Watt
- No Load Speed .....4.500 RPM
- Circular saw blade .....Ø 250mm - Bore=30mm
- Upper table dim. ....312x473mm
- Weight .....22 Kg

**Standard Equipment**

- Length stop - to make repetitive cuts of the same length
- Upper table fence for high precision cuts
- Dust extraction outlet
- Wrenches
- 1 HW circular saw blade, Ø250mm, Z40
- 1 year warranty
- Instruction manual

**Worldwide technical assistance**

DESCRIPTION	ORDER NO.
Compound miter saw 250mm with upper table	<b>CMT5</b>

**Suitable saw blades:**

<b>290.250.24M</b>	Ripping saw blades Ø250mm - Z24 ATB
<b>285.040.10M</b>	Ripping and crosscut saw blades Ø250mm - Z40 ATB
<b>285.060.10M</b>	Crosscut and finishing saw blades Ø250mm - Z60 ATB
<b>297.080.10M</b>	Non-Ferrous metal and laminated panels saw blades Ø250mm - Z80 TCG



**MADE IN ITALY**  
**CMT3**



**UNMATCHABLE PLANING ACCURACY**  
delivered by the aluminium front and rear shoes precision-machined after assembly

**PERFECT CONTROL**  
a steady cutting speed is insured by the ergonomically designed front handle

**SUPER FINE DEPTH ADJUSTMENT**  
with the scaled height-knob allowing 0-3mm micro-regulations



**STRAIGHT AND BEVELLED CUTS**  
thanks to the 0-45° tiltable guide included

**Technical Features and Specifications**

- Powerful motor for increased performance in the hardest of woods
- Knife guard
- Micro depth adjustment
- Horsepower . . . . . 850 Watt
- No Load Speed . . . . . 13.000 RPM
- Planing Width . . . . . 82mm
- Planing Depth . . . . . 0-3mm
- Max.Rabetting Depth . . . . . 23mm
- Weight . . . . . 2,8 Kg

**Standard Equipment**

- 0-45° tiltable guide for straight and bevelled cuts
- Scaled rabetting guide
- Dust extraction outlet
- Wrenches
- 2 HWM knives
- 1 year warranty
- Instruction manual

**Worldwide technical assistance**

DESCRIPTION	ORDER NO.
Hand planer with standard equipment	CMT3

<b>Spare knives:</b>	<b>790.820</b>	HWM Spare knives (set of 2 pcs.)
	<b>790.820.00</b>	HWM Spare knives (in box of 10 pcs.)

**MADE IN ITALY**  
**CMT2E**  
**CMT2E-B**

Base with large 75mm diameter aperture and pre-bored for CMT router table

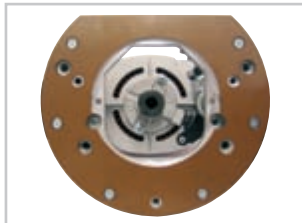

Dust extraction outlet



Template guide bushing 30mm



**ELECTRONIC 6-SPEED CONTROL**

From 8.000 - 22.000 RPM

**SWITCH-LOCKING DEVICE**

For use in a router table **only**.

**3-POSITION DEPTH STOP**

For fast depth changes.

**LONG SIDE-FENCE**

Easy micro-adjustment for guiding along a straight edge.

**COMFORTABLE HANDLES**

Molded shape provides solid, safe control of the router.



Spindle lock and 22mm spanner allow easy cutter changes



**Technical Features and Specifications**

- Solid, accurate, reliable
- Variable speed with soft start
- Long and accurate side fence with micrometer adjustment
- Precision adjustable depth stop with 3 settings
- Horsepower . . . . . 2.000 Watt
- No load speed . . . . . 8.000-22.000 RPM
- Plunge stroke . . . . . 0-75mm
- Collet diameter . . . . . Ø6-12,7mm
- Tool weight . . . . . 5,2 Kg

**Standard Equipment**

- Straight guide with fine fence adjustment for precision positioning of the parallel fence
- Dust extraction outlet
- Guide bushing 30mm
- Wrench for easy cutter change
- Ø8 and Ø12mm collets
- 1 year warranty
- Instruction manual

**Worldwide technical assistance**

**Collets for CMT2E**

796.860.00	D = 6mm
796.864.00	D = 6.35mm
796.880.00	D = 8mm
796.895.00	D = 9.5mm
796.900.00	D = 10mm
796.920.00	D = 12mm
796.927.00	D = 12.7mm

DESCRIPTION	ORDER NO.
Router complete with standard equipment	<b>CMT2E</b>
Router for table installation, basic equipment (dust extraction, wrench, Ø8 and Ø12mm collets, instruction manual)	<b>CMT2E-B</b>

Our quality bits were developed for you, the professional craftsman, to allow you to confidently work at your personal best. Now CMT offers you even more possibilities with our professional router table: the perfect place to combine your skill and our quality.

The CMT Professional Router Table System has a strong and sturdy MDF laminate work surface that measures 68 x 52 x 2,5cm for easy mobility when working.

## 999.100.00

Router table dimensions:

68x52x(h)90cm.

Weight 25 kg.



This free standing table sits at a comfortable height of 90cm on solid high gauge steel legs and weighs 25 kilograms. The universal plate are adaptable to all makes and models of routers on the market and provide shank holder options which let you select any bit diameter up to 100mm. Choose any of our wide range of CMT bits including multi profile bits, molding bits or even kitchen set bits and work easily and safely on the CMT professional router table.

DESCRIPTION	ORDER NO.
CMT professional router table system (complete)	999.100.00
<b>Parts included with the table:</b>	
1) High gauge steel legs	999.100.21
2) 25 mm thick MDF work surface with alu fluting	999.100.22
3) Aluminium plate Ø92mm, <b>prebored for CMT2E</b>	999.100.23
4) Aluminium ring Ø92-45mm	999.100.24
5) Longitudinal fence in aluminium	999.100.25
6) Lexan® and aluminium safety shield	999.100.26
7) Vacuum hose	999.100.27
8) Moulded ABS feather board	999.501.07
9) Miter gauge	999.501.08
<b>Optional:</b>	
Electric safety switch	999.100.11
Universal aluminium plate Ø92mm, not bored	999.100.28



**CMT's New Industrio™ Routing System takes a great tool and makes it even better, with new features that include a phenolic insert, integral aluminum scales and an improved fence. We also have added great optional features, including a rugged molded featherboard and a new miter gauge.**

**999.500.01**

**The System includes:**

**999.501.09**

**Unique Phenolic Top with New Insert Plate**

Now featuring an 298mm x 374mm insert plate, the top is milled from 12mm thick phenolic. A stable and very durable material, phenolic is much more resistant to warping than the melamine tops found on most router tables. The top also features new aluminum scales on both ends to help set the fence quickly and accurately.

**Fast, Easy Bit Changes**

There's no need to remove the router or fumble beneath the top to change bits. CMT's clever bent wrench allows you to change bits from above, quickly and easily. Shipping weight kg. 15

**999.501.10 Pivoting, Zero-Clearance Fence with New Clamping System**

Our extruded aluminum fence can be used as conventional locked-in-place fence or as a pivoting fence. New, quick-adjusting clamps on both ends of the fence make adjustments a breeze, especially when used in conjunction with the aluminum scales that we've added to the table top. The fence also includes a subfence of high density white plastic for an ultra smooth feeding surface, with a replaceable center section to create zero-clearance inserts. Shipping weight kg. 8,5

**999.501.03 Sturdy Melamine Cabinet**

The sturdy 20mm-thick melamine cabinet assembles quickly with posts and cross dowels, and includes a 2-door storage area to keep bits, wrenches and other tools safe and dust-free. Shipping weight kg. 32,5

Router table dimensions:  
79x59x (h) 93cm. - Weight Kg. 55

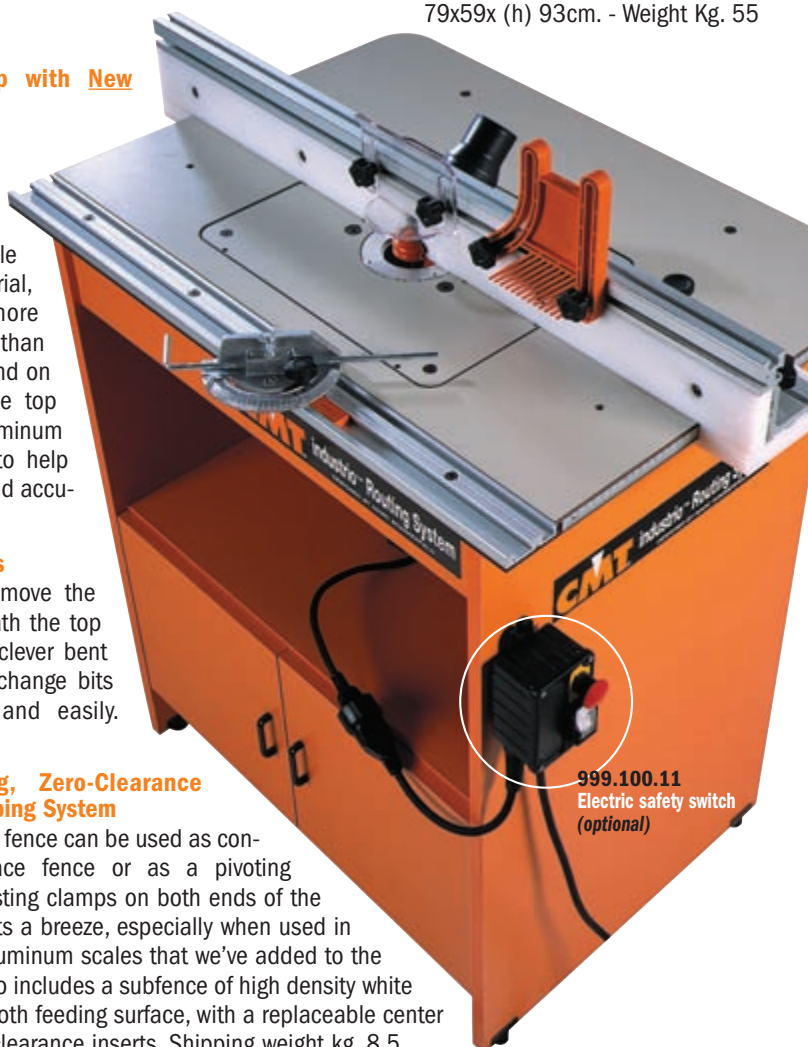

**999.501.07** \_Molded ABS featherboard mounts in table or fence slots. Includes nuts, bolts and plastic slide.



**999.501.08** \_Miter Gauge.



**999.501.16** \_Universal plate complete with aluminium rings for CMT2E.



**999.502.34** \_Router centering device allow you to position your router perfectly in the insert plate 8-12mm.

**Optional**

- 991.001.00**  
Bent Wrench 1-1/8" Porter Cable
- 991.002.00**  
Bent Wrench 53/64" Hitachi
- 991.003.00**  
Bent Wrench 15/16"  
Bosch & Makita
- 991.004.00**  
Bent Wrench 7/8" CMT,  
DeWalt & Fein
- 991.005.00**  
Bent Wrench 17mm
- 991.006.00**  
Bent Wrench 24mm



**Optional accessories**  
Bent Wrench allows easy bit changes.



**999.502.10** \_Center section of the fence is removable to make interchangeable insert.



**999.501.06** \_Dual post and guard helps make freehand work safer.

DESCRIPTION	ORDER NO.
Industrio™ routing system	<b>999.500.01</b>
<b>new</b> Industrio™ package CE APPROVED: Table 999.500.01 + Router CMT2E-B + Safety switch 999.100.11	<b>CMT2E-B+999.500</b>
<b>Optional:</b> Electric safety switch	<b>999.100.11</b>
Universal plate complete with aluminium rings, not bored	<b>999.501.11</b>



For the part-time woodworker, we have designed this compact work table to give you maximum versatility and maximum safety. We take your work and your safety seriously. The technicians here at CMT drew from their own experience to create this table as the ideal companion for the beginning woodworker. The laminated MDF surface sits 30cm high and measures 40 x 43 x 2cm, making it a spacious work area to easily accommodate all smaller model routers. The universal plate is adaptable to all makes of routers and can fit any size cutting diameter router bit up to 36mm. The perfect combination of quality and price.

# 999.200.00

Router table dimensions:  
43x40x (h) 30 cm. - Weight Kg. 7,3



DESCRIPTION	ORDER NO.
CMT router table (complete)	999.200.00
<b>Parts included with the table:</b>	
1) Heavy gauge steel legs	999.200.01
2) MDF laminated wood surface 43x40x20 centimetres	999.200.02
3) Universal plate for cutting diameter of up to Ø36mm	999.200.03
4) Alu support for wooden fence	999.200.04
5) Longitudinal fence in wood and aluminium	999.200.05
6) Lexan® support shield	999.200.06
7) Vacuum hose	999.200.07
8) Standing spring press	999.100.08
9) Moulded ABS feather board	999.501.07
<b>Parts not included with the table:</b>	
Electric safety switch	999.100.11

The innovative CMT-Enlock joining system is designed to build the strongest “T” joints, “Miter” joints and “Edge-to-edge” assemblies using the patented E15 and E10 dovetail keys. The dovetail slots in each part to be joined are machined quickly and accurately using the CMT-Enlock jig.

Simply clamp your workpiece in the jig, set the bit depth and you are ready to rout. The jig features strong cast aluminium construction throughout the body, top plate, stops and clamping bar producing perfect and strong joints for life!

# CMT-Enlock1

Patent No. AU2005/903586  
PCT/AU2006/000957

Width range 30~75mm  
Thickness range 19~35mm

**1.** Strong and versatile clamping bar ensures no movement of workpiece.

**2.** Solid cast aluminium body

**3.** Support foot to fix the jig on the table

**4.** Adjustable mitre blocks for mitre joints in picture frames

**5.** Mitre plate can be adjusted to suit width of workpiece.

**6.** Clamp extension arm to make widening joints.

**Supplied in a solid plastic box**

**Standard Equipment**  
Joining system **CMT-Enlock1**  
Masterpack (50 keys) **CMT-Enlock10**  
Instruction manual (five languages)  
Video available on [www.cmtutensili.com](http://www.cmtutensili.com)  
*HW Dovetail bit not included*

**A few seconds and your joints are ready!**

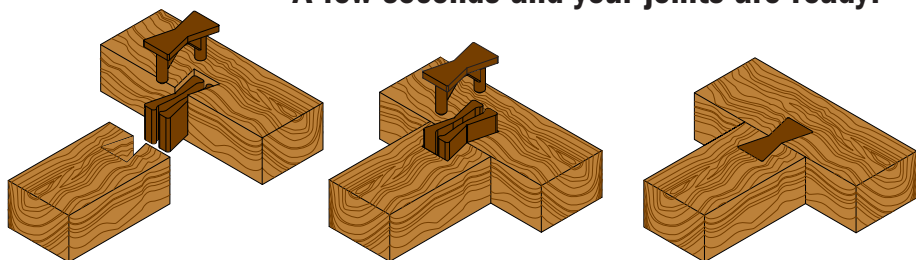

## Order now!

- CMT-Enlock1** Complete joining system
- CMT-Enlock10** Masterpack 50 keys Ø9,5mm
- CMT-Enlock15** Masterpack 50 keys Ø12,7mm
- 718.098.11B** Dovetail bit Ø9,5mm (shank 6mm)
- 718.127.11B** Dovetail bit Ø12,7mm (shank 6mm)
- 818.098.11B** Dovetail bit Ø9,5mm (shank 6,35mm)
- 818.128.11B** Dovetail bit Ø12,7mm (shank 6,35mm)

**Here are a few of the beautiful joints you can produce using CMT-Enlock Jig**

**T-Joint**

**Miter Joint**

**Edge-to-edge assemblies**

**Patented system**  
The CMT-Enlock dovetail key expands when the cap is forced in. This wedges the key in the joint producing a strong clamping force across the joint. No other dovetail system on the market produces this clamping force.

Dovetail joints give a lasting symbol of craftsmanship to your work, but many woodworkers avoid the joint due to its apparent complexity. CMT's new 305mm (12") Dovetail Jig is the fast, easy solution. With precise templates, permanent stops and easy adjustments, we've taken the "tinkering" out of dovetail joinery. You simply clamp your workpiece in with the edges against the factory-set stops, set your bit depth, and you're ready to rout. We haven't cut any corners on quality either. This jig features steel construction throughout - body, templates, stops and clamping bars - so it will still produce perfect joints long after jigs with lightweight plastic parts have gone to the scrap heap. The jig accepts stock from 11 to 25mm (7/16" to 1") thick, and is capable of producing a variety of joints with the available templates. The standard jig includes a template for 12,7mm (1/2") half blind joints, a template guide (some routers require adapter, see below), a CMT carbide tipped dovetail bit and complete instructions. Optional templates are also available for through-dovetail and box joints.

## CMT300

Max Length 305mm  
Joint Thickness 11~25mm

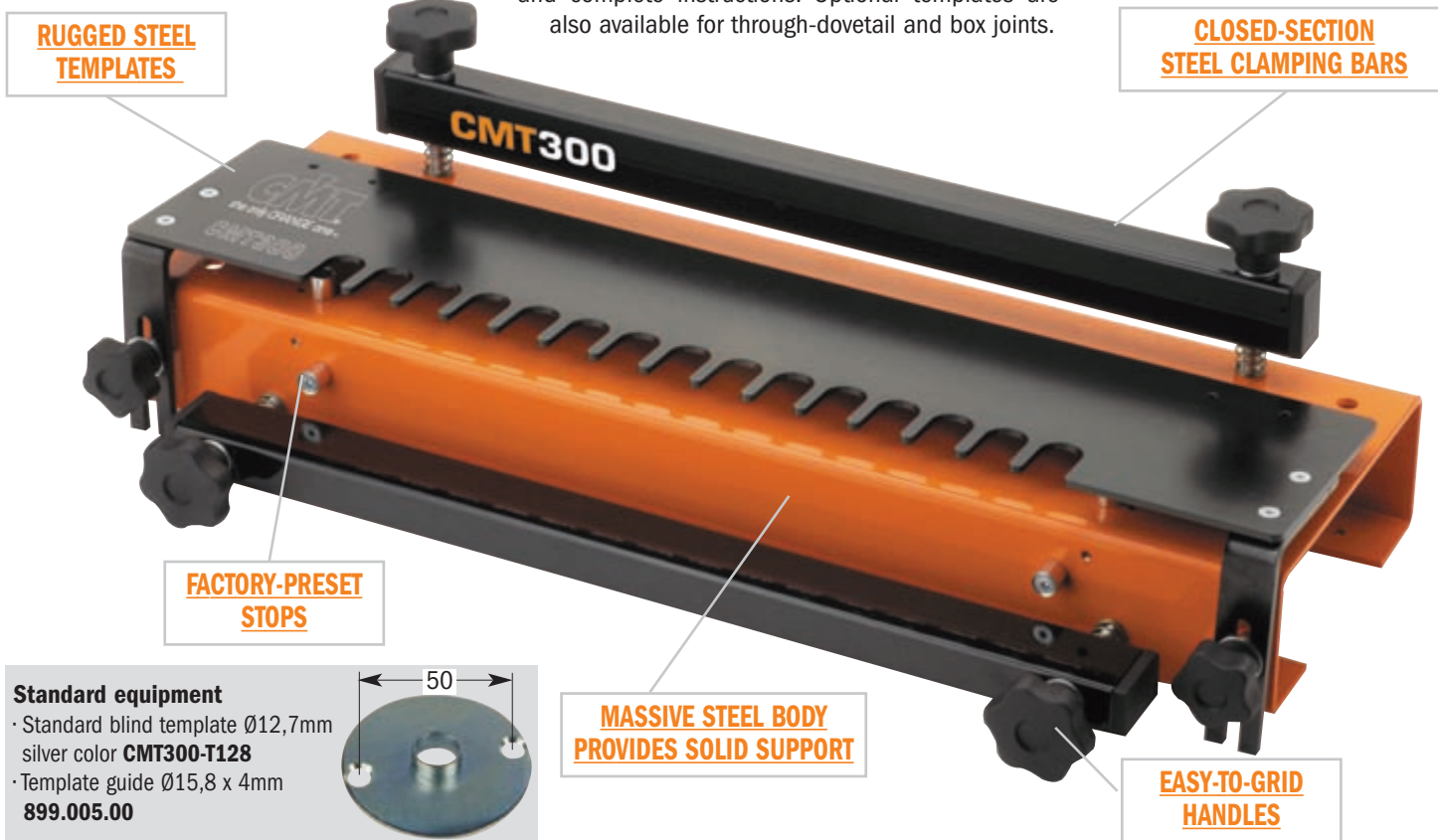

### Standard equipment

- Standard blind template Ø12,7mm silver color **CMT300-T128**
- Template guide Ø15,8 x 4mm **899.005.00**

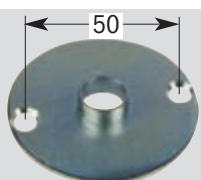

### IMPORTANT TIP

#### HW DOVETAIL BITS (not included):

718.127.11	D=12,7mm	A=14°	S=6mm
818.128.11	D=12,7mm	A=14°	S=6,35mm
918.127.11	D=12,7mm	A=14°	S=8mm
818.628.11	D=12,7mm	A=14°	S=12,7mm



#### Will the template guide fit my router?

The guides attach using two screws spaced 2" on center. Many routers accept this design. If your router does not, order the Universal Base listed below.

#### Universal router base

For shank=Ø8 and 12mm  
For shank=Ø6,35 and 12,7mm

Order no.

**CMT300-SB1**  
**CMT300-SB2**

### Here's how it works:

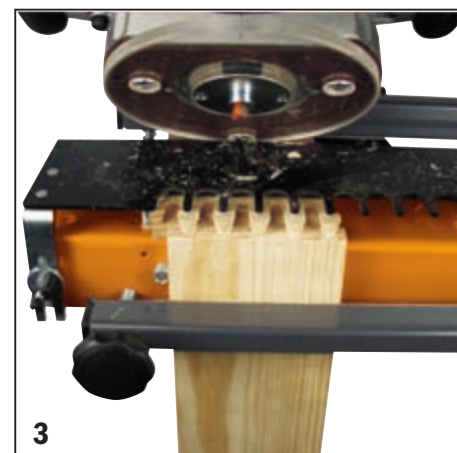
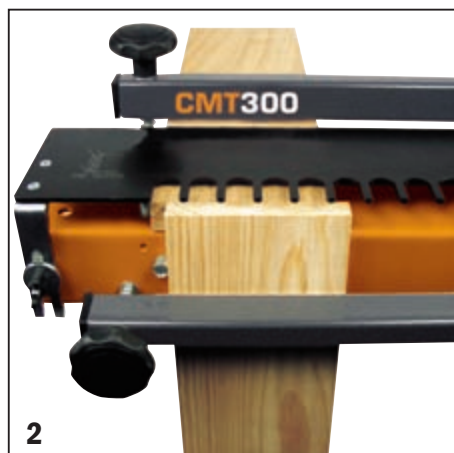



**Half blind template**



Template length mm	Dovetail size mm	Thickness mm	Color	ORDER NO.
300	6,3	8 ~ 12	green	<b>CMT300-T064</b>

Supplied with precision guide Ø7,8x4mm **899.003.00**

To be used with CMT dovetail router bits:  
 Bit HW Ø6 x 8mm (shank Ø6mm) **718.060.11**  
 Bit HW Ø6,35 x 8,3mm (shank Ø6,35mm) **818.064.11**

**Through dovetail template**

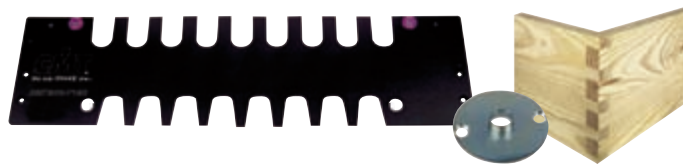

Template length mm	Dovetail size mm	Thickness mm	Color	ORDER NO.
300	12,7	8 ~ 20	brown	<b>CMT300-T129</b>

Supplied with precision guide Ø11,1x4mm **899.004.00**

To be used with CMT straight router bits:  
 Bit HW Ø8 x 25mm (shank Ø6,35mm) **811.081.11**  
 Bit HW Ø8 x 30mm (shank Ø8mm) **912.080.11**

To be used with CMT dovetail router bits:  
 Bit HW Ø12,7 x 20mm (shank Ø6,3mm) **818.129.11**  
 Bit HW Ø12,7 x 20mm (shank Ø8mm) **918.129.11**

**Box joint template**

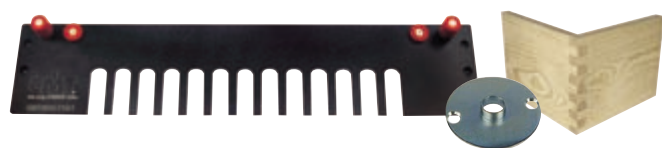

Template length mm	Dovetail size mm	Thickness mm	Color	ORDER NO.
300	8	8 ~ 20	blue	<b>CMT300-T080</b>

Supplied with precision guide Ø11,1x4mm **899.004.00**

To be used with CMT straight router bits:  
 Bit HW Ø8 x 25mm (shank Ø6,35mm) **811.081.11**  
 Bit HW Ø8 x 30mm (shank Ø8mm) **912.080.11**

Template length mm	Dovetail size mm	Thickness mm	Color	ORDER NO.
300	12,7	8 ~ 20	red	<b>CMT300-T127</b>

To be used with CMT straight router bits:  
 Bit HW Ø12,7 x 30mm (shank Ø6,35mm) **812.127.11**  
 Bit HW Ø12,7 x 30mm (shank Ø8mm) **912.127.11**  
 Bit HW Ø12,7 x 25mm (shank Ø12,7mm) **811.627.11**

Template length mm	Dovetail size mm	Thickness mm	Color	ORDER NO.
300	19	15 ~ 22	violet	<b>CMT300-T190</b>

Supplied with precision guide Ø22x4mm **899.006.00**

To be used with CMT straight router bits:  
 Bit HW Ø12,7 x 30mm (shank Ø6,35mm) **812.127.11**  
 Bit HW Ø12,7 x 30mm (shank Ø8mm) **912.127.11**  
 Bit HW Ø12,7 x 25mm (shank Ø12,7mm) **811.627.11**

To be used with CMT dovetail router bits:  
 Bit HW Ø19 x 22mm (shank Ø6mm) **718.190.11**  
 Bit HW Ø19 x 22mm (shank Ø6,35mm) **818.190.11**  
 Bit HW Ø19 x 22mm (shank Ø8mm) **918.190.11**  
 Bit HW Ø19 x 22mm (shank Ø12mm) **918.690.11**  
 Bit HW Ø19 x 22mm (shank Ø12,7mm) **818.690.11**

**Precision guide for router:**

7,8 x 4mm	<b>899.003.00</b>
11,1 x 4mm	<b>899.004.00</b>
15,8 x 4mm	<b>899.005.00</b>
22 x 4mm	<b>899.006.00</b>
30 x 4mm	<b>899.007.00</b>

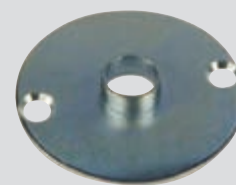

**Here are a few of the beautiful dovetail joints you can produce using CMT bits**

Half blind

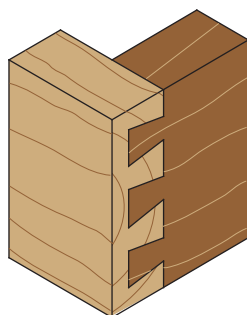

**CMT300 - T064**  
**CMT300 - T128 (INCLUDED with CMT300)**

Box Joint

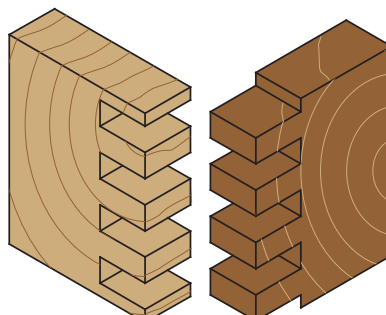

**CMT300 - T080**  
**CMT300 - T127**

Through Dovetail

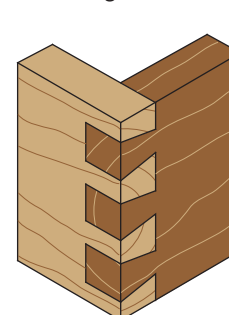

**CMT300 - T129**  
**CMT300 - T190**



# CMT3000

## Ellipse & Circle Cutting Jig

Designed to enable cutting of ellipses and circles with any type of router.

Simple and rapid system for cutting ellipses and circles for tables, windows, doors and other circle and ellipse shaped products.

With two slides in the T-slot, you can cut ellipses, by using one slide, the jig can be adapted for cutting circles.



Slider in T-Slot of the cross frame

### CMT3000 Ellipse Jig includes:

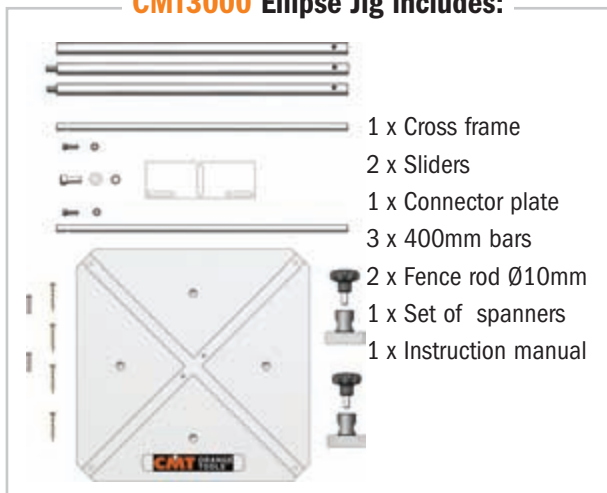

Major axis	Minor axes	
	Max	Min.
3000	2890	2590
1800	1690	1390
1500	1390	1090
1030	920	620
900	790	620
730	620	620
Cutting radius min/max		550/1500
Package dimension (mm)		405x360x54
Weight		6,6 kg.

### Ellipse & Circle Cutting Jig

- Exact and rapid forming of ellipses and circles.
- Simple setting-up and effective operating.
- Clamping system for all types of routers.
- Cross frame made of special plastic with excellent sliding performance.
- Precisely machined T-Slots and steel sliders.
- All metal parts zinc-coated against the effects of rust.
- Delivered in carton box including instruction manual.

### ACCESSORIES (optional):

#### Robust bar 400mm\_CMT3000-7

To extend the working radius.

#### 2 pcs of fence rod Ø8 for router\_CMT3000-8

For hobby or DIY router with bars up to 8mm in diameter.

### Here are few examples you can produce using Ellipse CMT3000

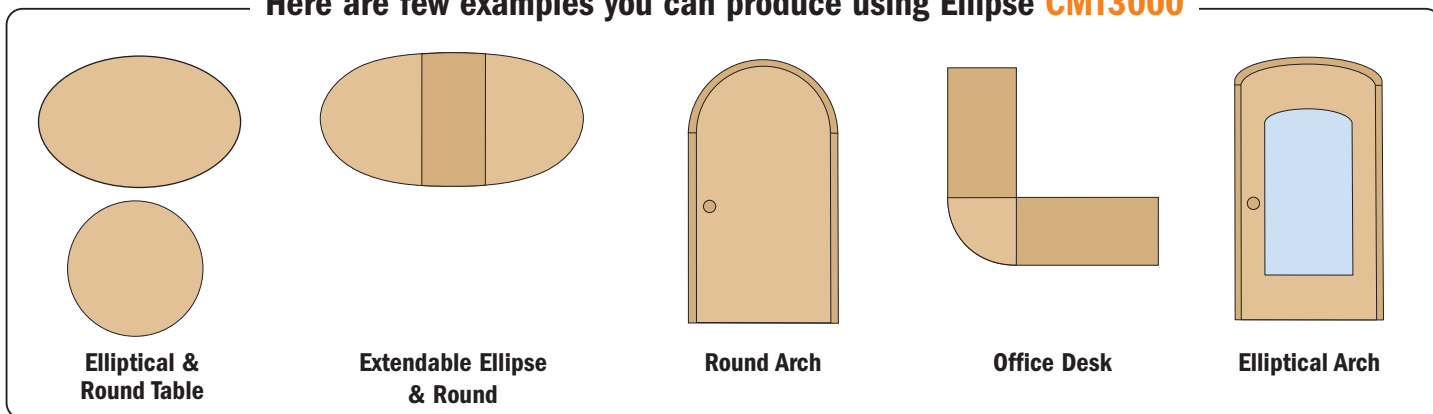

Elliptical & Round Table

Extendable Ellipse & Round

Round Arch

Office Desk

Elliptical Arch

DESCRIPTION	ORDER NO.
Ellipse & circle cutting jig	CMT3000



# CMT650

## FOR PERFECT JOINT

For kitchen worktop width from 420mm to 650mm

CMT650 is designed to cut kitchen worktop joints with any type of router.

Letter code system for different operations makes the work with the jig much easier and very quick.



**Joint made in 15 minutes! Including setting-up time.**

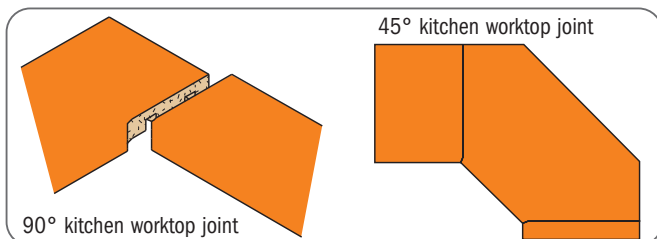

90° kitchen worktop joint

45° kitchen worktop joint

### JIG INCLUDES:

- 1x Phenolic Template
- 3x Zinc-coated steel location bush
- 1x Adjustable end stop
- 1x Instruction manual

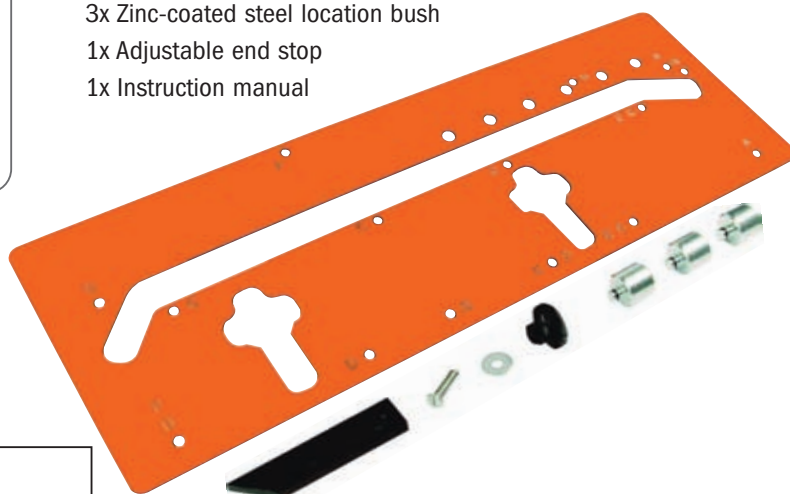

### JIG REQUIRES:

- Portable router
- Guide bush Ø30mm
- HW straight bit Ø12mm
- Two clamps

**Bits for the jig:**

We recommend the use of these straight bits Ø12mm:

912.120.11	Ø12x31,7 S=8mm
652.120.11	Ø12x28,3 S=8mm
912.621.11	Ø12x38,1 S=12mm
912.622.11	Ø12x50,8 S=12mm
812.620.11	Ø12x31,7 S=12,7mm
812.621.11	Ø12x38,1 S=12,7mm
652.121.11	Ø12x48,3 S=12mm
652.621.11	Ø12x48,3 S=12,7mm

### CMT650 is designed for 12mm straight bit.

- Template made of stable and hardened material.
- For joints of 90° and 45°
- Integrated templates for rounding over and chamfering edges.
- Extra location bush for worktop width of 600mm.
- Two integrated templates for panel bolt recesses.
- Delivered with clear and comprehensive instruction manual.

DESCRIPTION	ORDER NO.
Kitchen worktop jig	CMT650



**MADE IN ITALY**

**CMT333**

The innovative CMT333 hinges boring system with 3 spindle-head allow you to bore the holes for any hinges brand, from Salice to Blum, from Hettich to Würth, from Mepla to Grass.

The universal modular base supports the installation of 5 different boring heads engineered by the worldwide leading company for the industrial boring machines.

Use the CMT333 universal hinges boring system on all hand or standing drilling power tools!

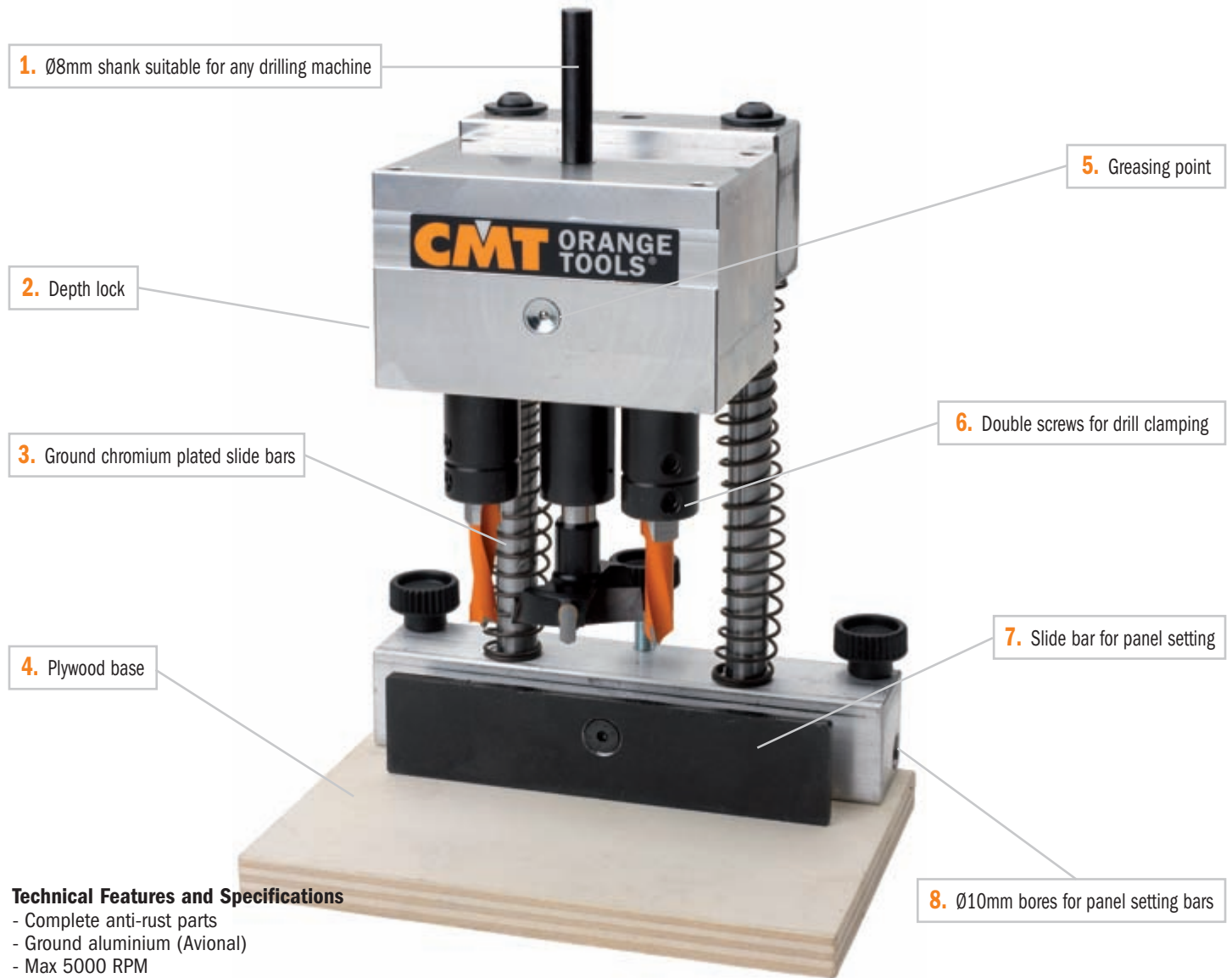

**Technical Features and Specifications**

- Complete anti-rust parts
- Ground aluminium (Avional)
- Max 5000 RPM
- Six radial antifriction bearings

**Safety Tips:** for lubrication use oil Mobil SHC100



To use on standing drilling machines



To use on standing drilling power tools



To use on CMT Industrio™ router table

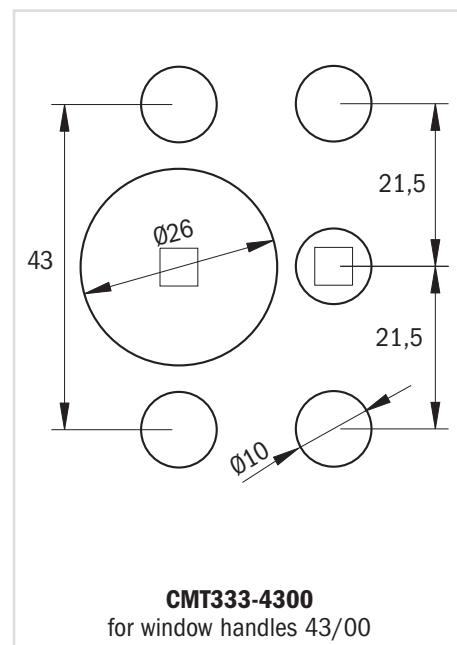
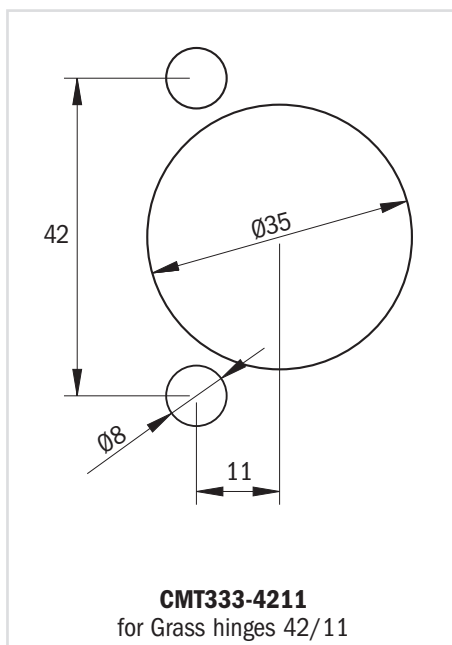
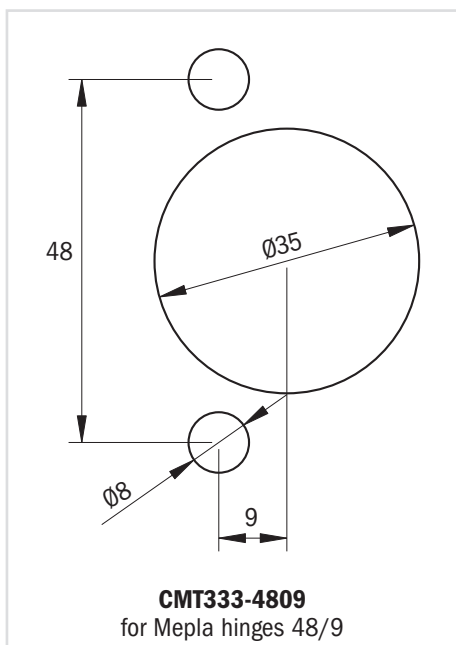
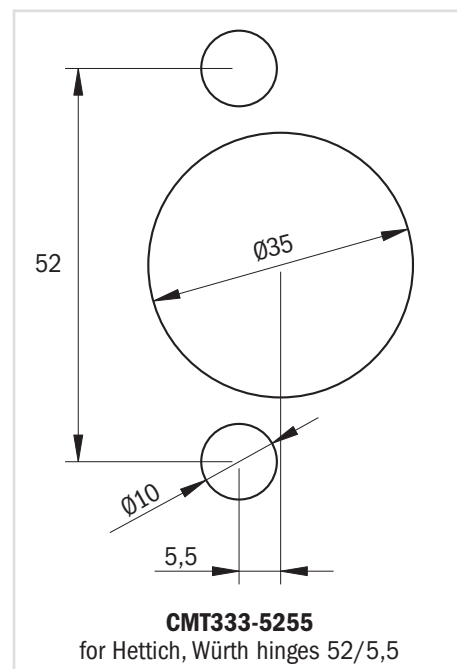
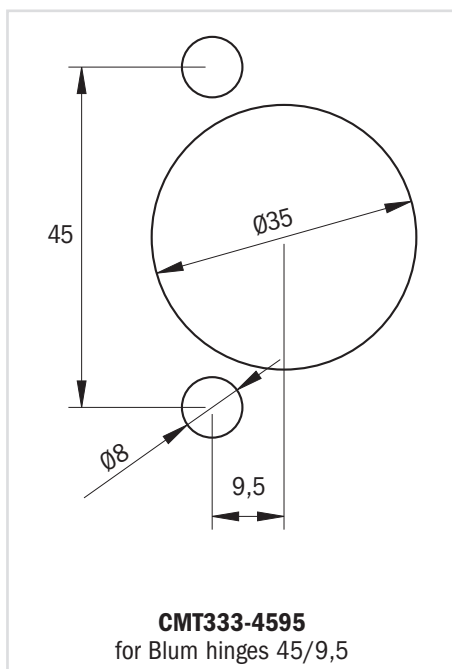
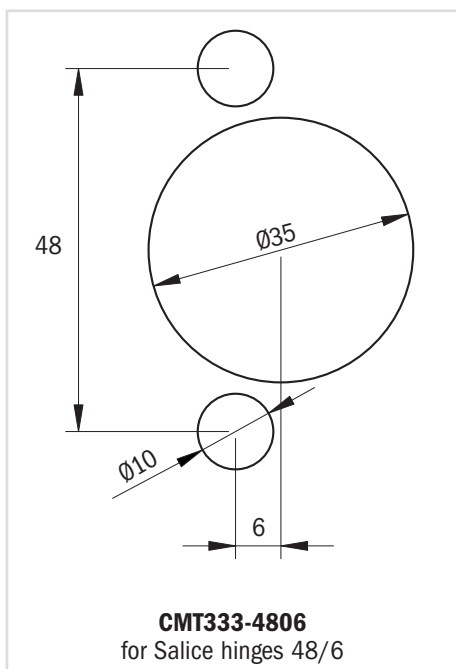

**MAXIMUM VERSATILITY FOR ANY BRAND**

Make your set	Support modular base	Boring heads	Drill bits	Boring bit
<p><b>Choose your hinge</b></p> <ul style="list-style-type: none"> <li>Salice 48/6</li> <li>Blum 45/9,5</li> <li>Hettich, Würth 52/5,5</li> <li>Mepla 48/9</li> <li>Grass 42/11</li> <li>Window handles 43/00</li> </ul>	<p><b>ORDER NO.</b></p> <p><b>CMT333</b></p> <p><i>Supplied in plastic box</i></p>	<p><b>ORDER NO.</b></p> <ul style="list-style-type: none"> <li>CMT333-4806 Salice</li> <li>CMT333-4595 Blum</li> <li>CMT333-5255 Hettich</li> <li>CMT333-4809 Mepla</li> <li>CMT333-4211 Grass</li> <li>CMT333-4300 W/handles</li> </ul>	<p><b>ORDER NO.</b></p> <ul style="list-style-type: none"> <li>310.100.12 (2 pz.)</li> <li>310.080.12 (2 pz.)</li> <li>310.100.12 (2 pz.)</li> <li>310.080.12 (2 pz.)</li> <li>310.080.12 (2 pz.)</li> <li>310.100.12 (2 pz.)</li> </ul>	<p><b>ORDER NO.</b></p> <ul style="list-style-type: none"> <li>317.350.11</li> <li>317.260.11</li> </ul>

Universal boring template is designed for precise and productive manual dowelling of furniture elements into a surface with 32mm euro-system, for boring of holes for shelf supports with a diameter of Ø3 and Ø5mm and for boring and marking of holes for hinges. CMT900 contains templates for preboring of holes for the most used hinges. Using the CMT900 template, you can make holes for screws or wood screws of hinge washers on the base element as well as prebore holes for the door hinge including the marking of the Ø35mm hole for the hinge.

CMT900 helps you to obtain high precision and productivity of work. The template is designed to be used with the special boring adaptor CMT400-1 which supports all kind of drill bits (shank 8mm) with different diameters.

## CMT900

*For dowelling into a surface*

*For shelf supports*

*For hinges*

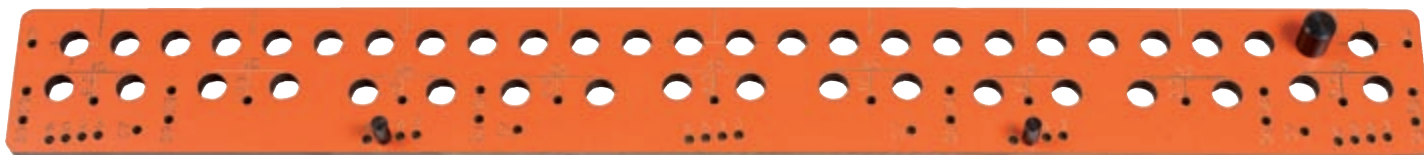

**Laminated phenolic material**

**Clear and understandable template marking**

**Precise end stops**

**QUICK AND EASY:**

Technical data:	CMT900
Max. board width in one tightening:	900mm
Max board width:	no limits
Board thickness:	no limits
For dowels:	Ø8mm
Distance of holes:	32mm
Number of holes:	26
For shelf support:	Ø3mm, Ø5mm
For hinges:	Ø3mm for wood screws Ø5mm for euro screw

Boring into surface for dowel joint using the template.

Boring holes of Ø3 and Ø5mm for shelf supports.

Preboring of holes for hinges (base and panel).

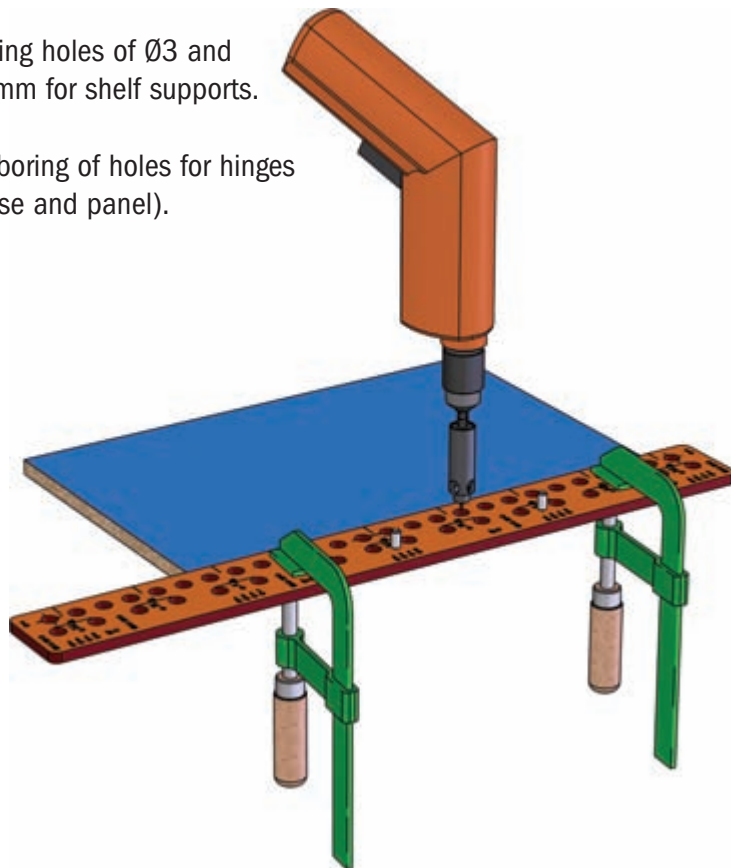

**BORING ADAPTORS (not included):**

- End stop for different boring depths
- Suitable for any type of drilling machine
- Duralumin body with holes for better chip ejection
- Precise and flat seating for proper alignment.

order no. **CMT400-1**

Boring adaptor for CMT400, CMT656, CMT900 JIGS to be uses with drill bits up to 30mm depth:  
306.030.21 - 306.050.11 - 306.080.11



**HW DOWEL BITS (not included):**

306.030.21	D=3x18mm	S=8mm	HWM
306.050.11	D=5x30mm	S=8mm	HW
306.080.11	D=8x30mm	S=8mm	HW

Other sizes availables in series 306-307

**CMT900 Boring Template includes:**

- Boring template from laminated pertinax
- Set of end stops
- Set of end stops for large elements
- Centering pin for hinges

DESCRIPTION	ORDER NO.
Universal boring template	CMT900



**CMT400**  
**CMT656**

Universal boring jig is designed for precise and productive manual dowelling of furniture elements. The jig helps you to obtain high precision and productivity of work. The positions of holes are constructed with a distance of 32mm which is in accordance with standard euro norm for machine dowelling. The dowel jig is designed for CMT drill bits, shank 8 mm, HW material, clamped into a special boring adaptor.

**For edge dowelling and jointing**

**Precise holes**

**Detachable end stops**

**Ergonomic manual tighteners**

**Precise and flat duralumin profile**

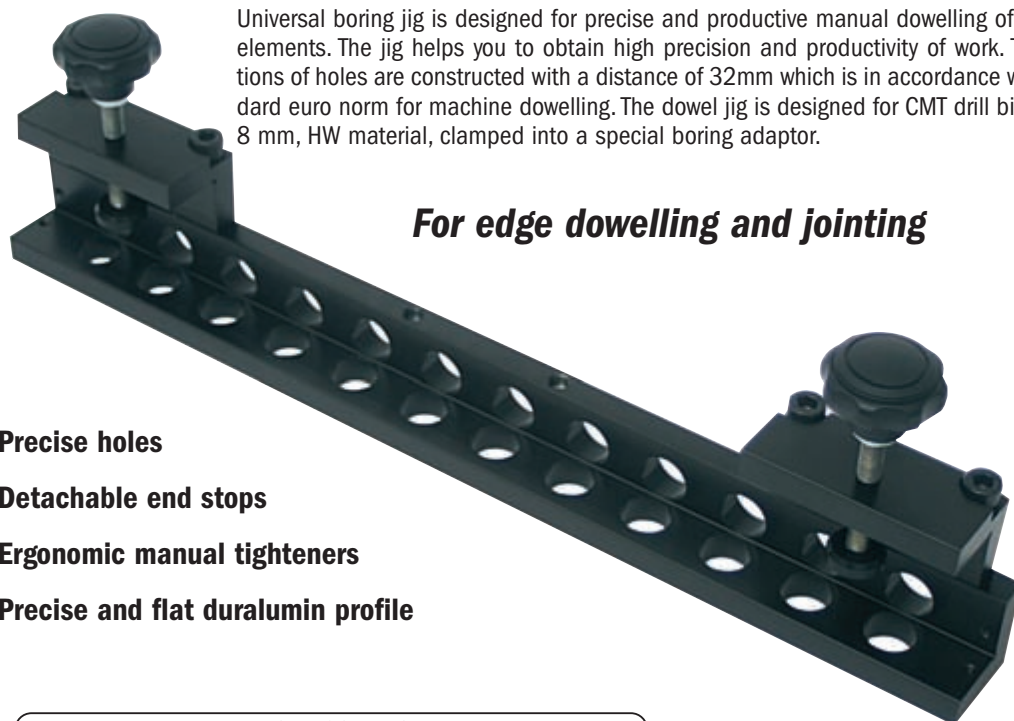

**SPARE CLAMP (optional)**

To speed up your work with elements of different width. Code **CMT400-3**



**UNIQUE SOLUTION**

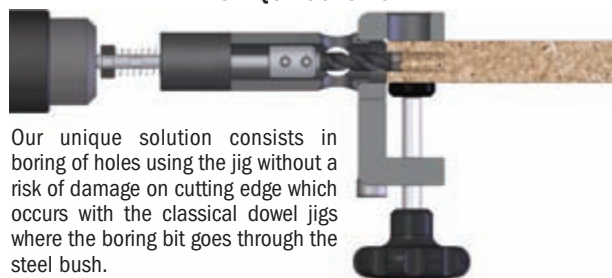

Our unique solution consists in boring of holes using the jig without a risk of damage on cutting edge which occurs with the classical dowel jigs where the boring bit goes through the steel bush.

**BORING ADAPTORS (not included):**

- End stop for different boring depths
- Suitable for any type of drilling machine
- Duralumin body with holes for better chip ejection
- Precise and flat seating for properly alignment.

order no. **CMT400-1**

Boring adaptor for CMT400, CMT656, CMT900 JIGS to use with drill bits up to 30mm depth: 306.030.21 - 306.050.11 - 306.080.11 - 307.050.11

order no. **CMT400-2** (for screw joints)

Boring adaptor for CMT400, CMT656, CMT900 JIGS to use with drill bits: 307.050.11



**HW DOWEL BITS (not included):**

- |            |          |       |                     |
|------------|----------|-------|---------------------|
| 306.030.21 | D=3x18mm | S=8mm | HWM                 |
| 306.050.11 | D=5x30mm | S=8mm | HW                  |
| 306.080.11 | D=8x30mm | S=8mm | HW                  |
| 307.050.11 | D=5x40mm | S=8mm | HW for screw joints |
| 307.070.11 | D=7x40mm | S=8mm | HW for screw joints |
- Other sizes availables in serie 306-307-367-368



**3 Easy steps for your dowel joints**



Put the jig on the board, fix the end stop and tighten it. Set the bore depth and clamp the boring adaptor on your drilling machine. Bore the vertical holes.



Fasten the jig on the other element, fix the end stop and set the bore depth. Bore the horizontal holes.



Now just put the dowels with glue into the holes and joint both elements.



Or use through holes bits and screw the elements together.

Technical data:	<b>CMT400</b>	<b>CMT656</b>
Max. board width in one tightening:	400mm	656mm
Max board width:	no limits	
For dowels:	Ø8mm	Ø8mm
For through holes:	Ø7mm	Ø7mm
Distance of holes:	32mm	32mm
Number of holes:	2x12	2x20
Board thickness:	16-40mm	16-40mm
Facet (elements lap):	0,8mm	0,8mm

DESCRIPTION	ORDER NO.
Universal boring jig (400mm in one tightening)	<b>CMT400</b>
Universal boring jig (656mm in one tightening)	<b>CMT656</b>

## For professional, Industrial and home users

- FAST** Quality real diamonds, the hardest material known, reduces the sharpening process.
- EASY** With little pressure, stroke blade across surface.
- DURABLE** Natural diamond used guarantees a long life.
- VERSATILE** Hones any hard material, steel, glass, ceramic and tungsten carbide, etc.

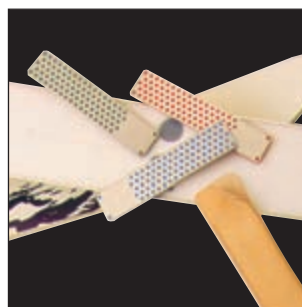

### Sharpen, hone and lap

- axes
- bayonets
- broadheads
- cable cutters
- carbide cutters
- chainsaws
- chisels
- climbing equipment
- engraving tools
- farm and garden tools
- fish hooks
- Fostner bits
- knives
- lapidary tools
- lawn mower blades
- masonry borer
- moulds and dies
- plane blades
- planer /jointer knives
- pruners
- ring tool
- router bits
- saw blades
- scissors
- shears
- ski and snowboard edges
- small contact area and pointed tools
- speed and hockey skates
- woodcarving scrapers
- woodturning tools

### Abrades hard material

- ceramic
- composites
- fibreglass
- glass
- stainless steel
- stone
- titanium
- tool steel
- tungsten carbide

### Flatten

- chisel backs
- engine heads
- machine bolsters and ways

### Mini-diamond whetstone in plastic case

Dimensions mm	Grains	Colour	ORDER NO.
70 x 24 x 2	D15 extrafine	green	DSS-070E
70 x 24 x 2	D25 fine	red	DSS-070F
70 x 24 x 2	D46 coarse	blue	DSS-070M

### Universal diamond whetstone in leather sheath

Dimensions mm	Grains	Colour	ORDER NO.
115 x 25 x 3	D15 extrafine	green	DSS-115E
115 x 25 x 3	D25 fine	red	DSS-115F
115 x 25 x 3	D46 coarse	blue	DSS-115M
115 x 25 x 3	D76 extracoarse	black	DSS-115G

### Diamond whetstone hinged, double sided

Dimensions mm	Grains	Colour	ORDER NO.
115 x 25 x 5	D15/25 extrafine/fine	green/red	DSS-115EF
115 x 25 x 5	D15/46 extrafine/coarse	green/blue	DSS-115EM

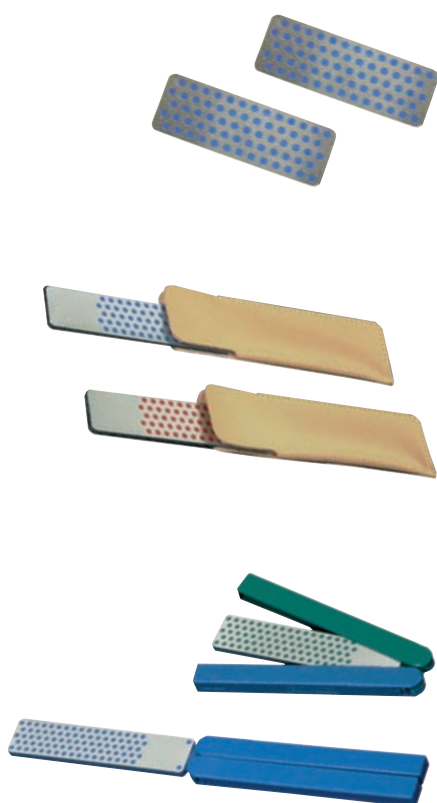

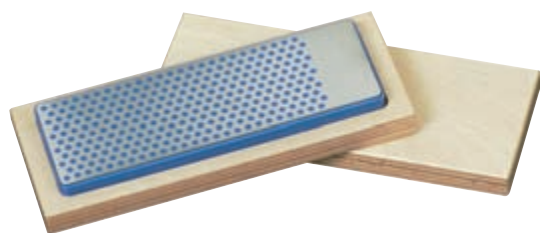

**Universal diamond whetstone in hardwood case**

Dimensions mm	Grains	Colour	ORDER NO.
150 x 52 x 16	D15 extrafine	green	DSS-150E
150 x 52 x 16	D25 fine	red	DSS-150F
150 x 52 x 16	D46 coarse	blue	DSS-150M
150 x 52 x 16	D76 extracoarse	black	DSS-150G



**Diamond whetstone file**

Dimensions mm	Grains	Colour	ORDER NO.
100 Ø4,8	D54 coarse	blue	DSS-048M

**Unique production process guarantees a long life**

A perforated steel plate is moulded onto a strong plastic base using high pressure. The steel is then covered with natural diamonds embedded in nickel plate. The pattern of diamond coating ensures fast sharpening while the plastic indents hold the lubricating water and disperse the fine dust that the diamonds remove during the sharpening process.

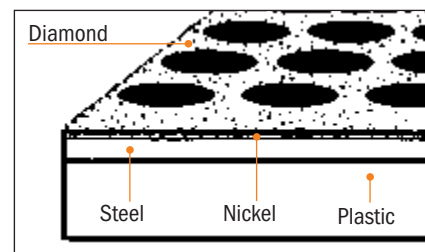

**The diamond whetstones are available in four mesh for different purposes:**

**D15 EXTRAFINE/GREEN** (9 microns, 1200 mesh)

Refines and polishes the sharp edges to razor sharp perfection. If you are new to sharpening or if you do not need your knife or tool edge to be as sharp as absolutely possible, this grit is not recommended. But if it's not sharp until it's sharp enough for you, this is the grit you are looking for!

**D25 FINE/RED** (25 microns, 600 mesh)

Restores to a fine edge any knife or tool that is slightly dull. Many of our customers consider the fine grit to be medium/all purpose sharpener. Professional Chefs and gourmet cooks prefer using our fine grit models. For woodworkers and sportsmen who are stepping through the grits, it's the edge refinement step done before micro bevelling and polishing.

**D46 COARSE/BLUE** (45 microns, 325 mesh)

Quickly restores a dull edge to cutting sharp again. Customers that desire cutting fast action without worry of edge refinement often use our coarse models.

**D76 EXTRA-COARSE/BLACK** (60 microns, 220 mesh)

Recommended for aggressive removal of metal on damaged tools or for heavy-duty outdoor tools such as axes and lawn mower blades. Also commonly used as the first step in flattening the backs of chisel and plane irons and for rapid stock removal from a chipped or badly damaged edge.

**INSTRUCTIONS**

*Use water for lubrication, after use, rinse and store dry.*

**1.** Keep your knife with cutting edge away from you.

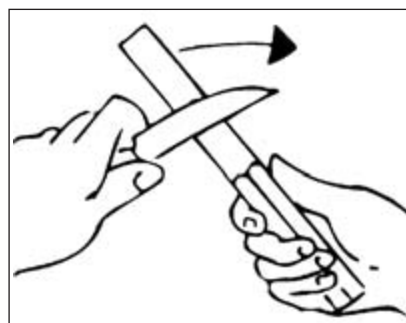

**2.** Apply some water to the stone surface. Hold blade 20° to diamond surface.

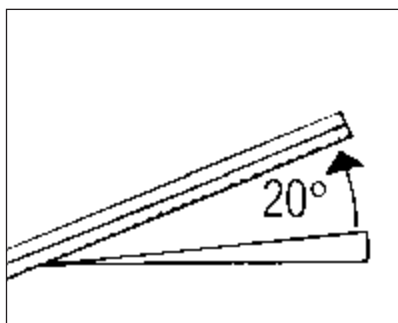

**3.** With little pressure and in long strokes push the blade across surface. From edge heel to edge tip, alternately on both sides. For pointed tools. Use the unperforated diamond area.

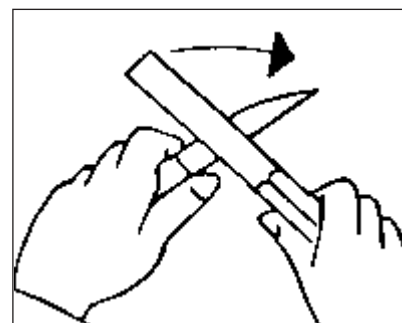



**899**



Making the beautiful effects of professional inlays isn't as difficult as it may seem if you start with the CMT Inlay Kit. Solid brass components come with either a solid carbide spiral bit or straight bit with 3,2mm (1/8") cutting diameter and 6,35mm (1/4") shank. The interchangeable brass bushing and your own template design make it easy - just remove and re-assemble the small bushing to make the recess in the workpiece and cut out the inlay.

The CMT Inlay Kit gives you unlimited decorative possibilities and is the perfect tool for toymaking, puzzle making and lettering ideas.

Spiral bit recommended for use in MDF.

Straight bits recommended for natural wood.



Complete instructions for how to assemble and use the CMT Inlay Kit are included in the kit.

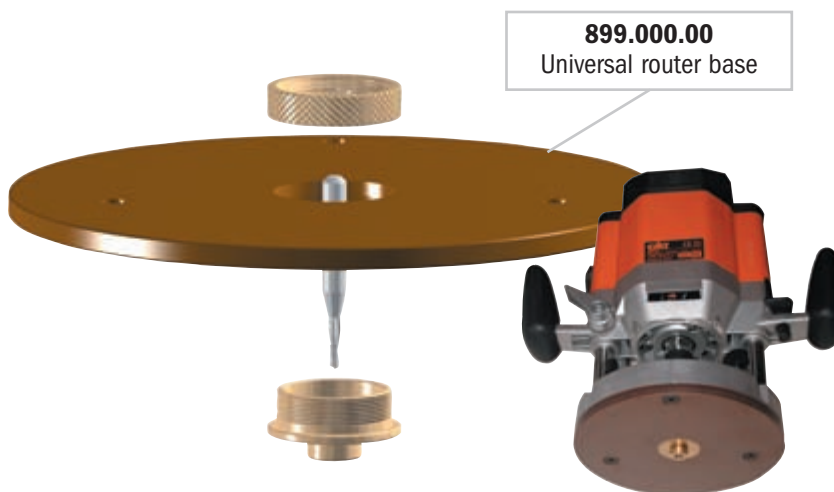

**899.000.00**  
Universal router base

DESCRIPTION		ORDER NO.
Inlay kit with 3,2mm (1/8") HWM spiral bit	Shank Ø6,35mm	<b>899.051.00</b>
Inlay kit with 3,2mm (1/8") HWM straight bit	Shank Ø6,35mm	<b>899.052.00</b>
Solid brass template guide		<b>899.001.00</b>
Universal router base		<b>899.000.00</b>
HWM spiral bit 3,2mm (1/8")	Shank Ø6,35mm	<b>192.001.11</b>
HWM straight bit 3,2mm (1/8")	Shank Ø6,35mm	<b>812.032.11</b>
HWM spiral bit 3mm	Shank Ø6mm	<b>192.630.11</b>
HWM straight bit 3mm	Shank Ø6mm	<b>712.030.11</b>

### Here's how it works:

**Make your pattern**

Make a pattern in the desired shape of your inlay out of 6,35mm (1/4") material. For best results, use Masonite or a similar smooth material, avoid square corners, and be sure the opening is wide enough to accommodate the 14,2mm (9/16") bushing.

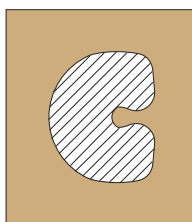

**Rout the workpiece**

Attach the brass inlay guide to your router with the snap-on bushing in place. Set the bit depth to match your inlay stock. Attach the pattern to your workpiece, and rout out the mortise for the inlay.

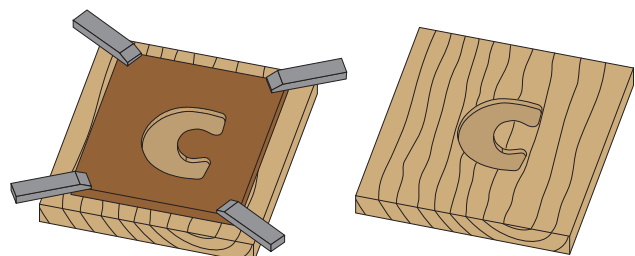

**Rout the inlay**

Temporarily attach the inlay stock to a piece of scrap with two-sided tape. Now attach your pattern to the inlay material. Take off the snap-on bushing, and very carefully rout around the opening in the pattern. Be sure the template guide stays tight to the perimeter of the pattern at all times.

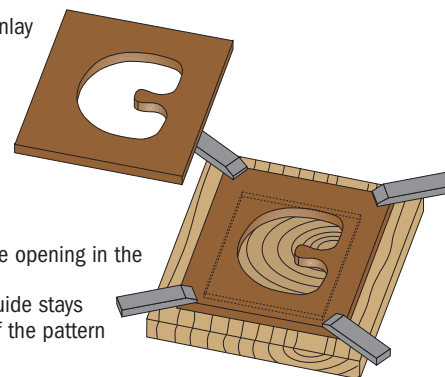

**Put it all together**

Test fit the parts, and lightly sand the inlay material if necessary. Apply adhesive, and carefully tap the inlay in place. Use a block of wood to protect the inlay stock. Sand as needed, and you're finished!

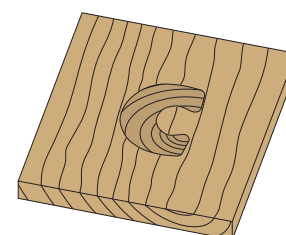

Complete detailed english instructions included with the Inlay Kit  
Spanish, French, German and Italian instructions available on [www.cmtutensili.com](http://www.cmtutensili.com)

For fast, easy and accurate cabinet & furniture construction, there's never been a tool like the **Pocket-Pro™ Joinery System**. Developed by CMT and professional cabinetmakers this new system lets you make rock-solid pocket hole joints in stock from 12,7mm (1/2") to 40mm (1-5/8") thick, with unprecedented speed and accuracy.

The heart of the Pocket-Pro™ System is our unique molded jig, which features hardened drill bushings and an interlocking 2-piece design. Simply sliding the jig up or down allows you to adjust for stock thicknesses in preset 1,6mm (1/16") increments, without test joints or measurements! If you have used other pocket hole jigs you will be familiar with many applications of the joint, **but** you will enjoy some big advantages with the Pocket-Pro. *For example:*

- Some jigs require that you add or remove various portions of the jig to join different stock thicknesses. **Not the Pocket-Pro!** You simply adjust the interlocking jig up or down for the full range of joints, from 12,7mm (1/2") to 40mm (1-5/8") thick!
- Other jigs require frequent repositioning of the Depth Stop Collar for different styles of joint. **Not the Pocket-Pro!** The vast majority of adjustments allow you to leave the Stop Collar in the same position on the drill bit!
- Plus, with the **Pocket-Pro**, you can quickly adjust the location of the pocket in relation to the end of your workpiece to create a stronger joint by using longer screws or to leave more "meat" in the joint.

Check out the Pocket-Pro Joinery System today. Easy enough for the beginner and accurate enough for the pro, the Pocket-Pro is the world's most versatile pocket hole jig.

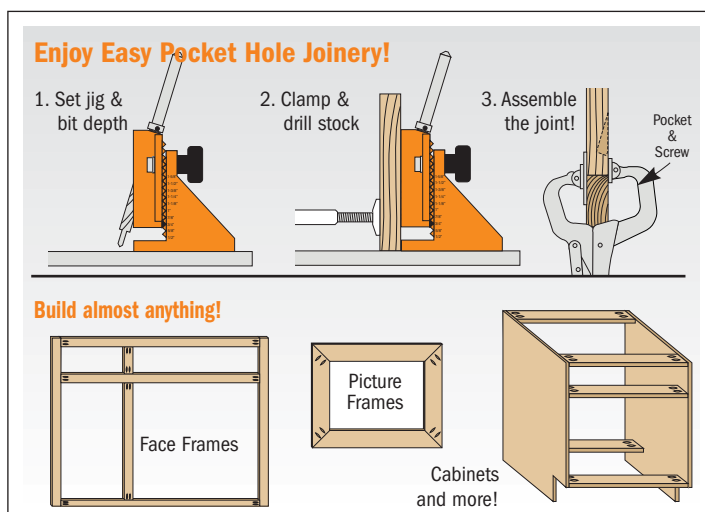

**The Pocket-Pro is now offered in two packages:**

**PPJ-002 Pocket-Pro™ Starter Set:**

Perfect for anyone who wants an economical introduction to pocket hole joinery, this set is also an ideal choice for woodworkers who want to upgrade from another jig. It includes the two-piece molded jig, toggle clamp, 9,5mm (3/8") step drill bit, stop collar, #2 driver bit and sample screws.



Jig, Toggle Clamp, Drill Bit, Stop Collar, Driver Bit & Sample Screws.

**PPJ-001 Pocket-Pro™ Deluxe Set:**

Packed in a beautiful molded case, the Deluxe system includes the molded jig, an 298mm x 374mm phenolic base (same as in our **CMT Industrio™ Routing System**), a toggle clamp, face clamp, two step drill bits, stop collar, two drivers & sample screws.



All parts fit neatly in molded case

Everything in the Starter Set Plus: Base Plate, Face Clamp & Case

POCKET-PRO PARTS AND ACCESSORIES	ORDER NO.
9,5mm (3/8") step drill bit	<b>515.001.51</b>
9,5mm (3/8") depth collar for step drill bit	<b>541.095.00</b>
Toggle clamp	<b>999.505.05</b>
Face clamp with swivel pad	<b>999.505.06</b>
#2 x 76mm (3") Square drive screwdriver bit	<b>999.505.07</b>
#2 x 152mm (6") Square drive screwdriver bit	<b>999.505.08</b>

POCKET-PRO PARTS AND ACCESSORIES	ORDER NO.
500 screws 31,7mm (fine)	<b>999.101X500</b>
500 screws 31,7mm (coarse)	<b>999.102X500</b>
500 screws 38,1mm (fine)	<b>999.103X500</b>
500 screws 38,1mm (coarse)	<b>999.104X500</b>

## 100 bits at your fingertips

When you are constantly working on projects, you always need your most used bits right on hand and safely organized. CMT gives you the perfect solution for keeping it all in sight and within reach with our 100 piece organizer. Conveniently holds any size router or drill bit by using our interchangeable bushings to fit all CMT shank diameters. See options listed below.

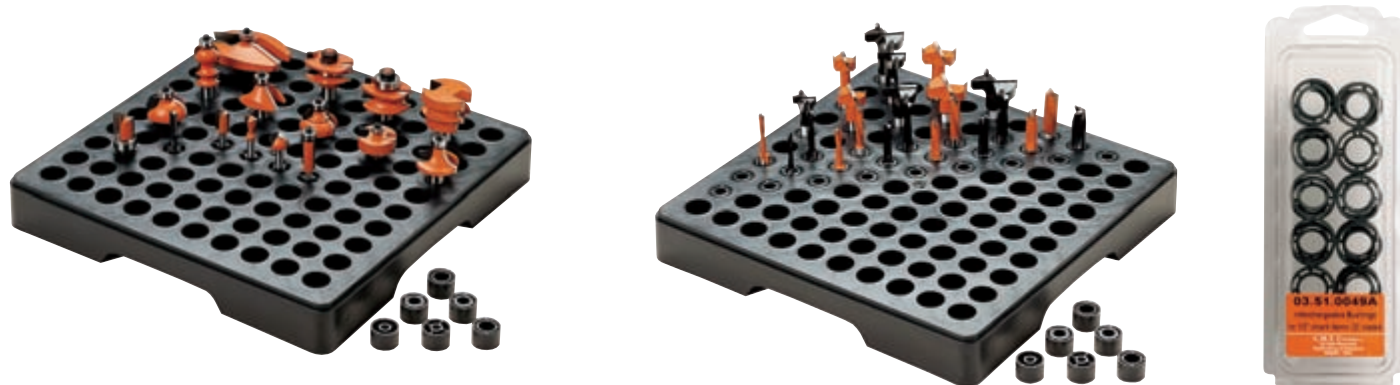

DESCRIPTION	ORDER NO.
Bit organizer (without bushings)	03.51.0106
Interchangeable bushings for shank Ø6mm (20 piece)	03.51.0046A
Interchangeable bushings for shank Ø6,35mm (20 piece)	03.51.0047A
Interchangeable bushings for shank Ø8mm (20 piece)	03.51.0048A
Interchangeable bushings for shank Ø9,5mm (20 piece)	03.51.0057A
Interchangeable bushings for shank Ø10mm (20 piece)	03.51.0058A
Interchangeable bushings for shank Ø12mm (20 piece)	03.51.0059A
Interchangeable bushings for shank Ø12,7mm (20 piece)	03.51.0049A

## Formula 2050 blade and bit cleaner

*Finally, a safe, environmentally-friendly cleaner that is more effective than all of those hazardous chemicals used to clean cutting tools.*

Saw shops know how to get the most out of cutting tools. They know that the pitch and resin that wood leaves behind greatly shortens the useful life of carbide. We had several quality saw blade sharpeners across the country test our Formula 2050. "Phenomenal" and similar words were heard over and over about the performance of Formula 2050.

Most blade and bit cleaning products work with a dissolving action. It takes some powerful and nasty chemicals to dissolve wood residues and adhesives.

Our safe and non-toxic Formula 2050 penetrates the microscopic cracks in the resin and attacks the bond between it and the carbide or steel surfaces.

The resin releases its grip and you simply wipe it off. A clean cutting surface runs cooler and works less in the cut. The excess friction of a resin-coated blade causes heat build-up and carbide breakdown.

Formula 2050 keeps your tools clean and helps you increase the life span between sharpenings and replacement. We guarantee your satisfaction with the performance of our CMT Formula 2050 Blade and Bit Cleaner.



- Removes pitch, resin and adhesive residue from all woodworking cutting tools (saw blades, router bits, drill bits, shaper cutters, planer blades, etc.).
- Completely non-toxic, non-flammable and certified biodegradable. Formula 2050 is a safe, earth-friendly product.
- Do not rinse after cleaning. Formula 2050 provides protection from rust and corrosion. Keeps your table saw top rust free too!
- Can be applied by spray bottle or used in ultrasonic cleaners and dip tanks.

★★★★★ **This product received a five-star performance rating from "Wood® Magazine"**

DESCRIPTION	ORDER NO.
0,500 lt. spray bottle (master packaging 10 bottles)	998.001.01
3,780 lt. plastic jug	998.001.03



**7/900.003**



CMT has put your an entire workshop in a box - the 26 piece super set has it all. Complete with a wide selection of the most requested routers, this super set includes straight bits, flush trim bits, dovetail bits, coves, ogees and more. Your creative potential is endless. Ideal for the master craftsman. Available in 6mm and 8mm shank diameters - see chart below for details.

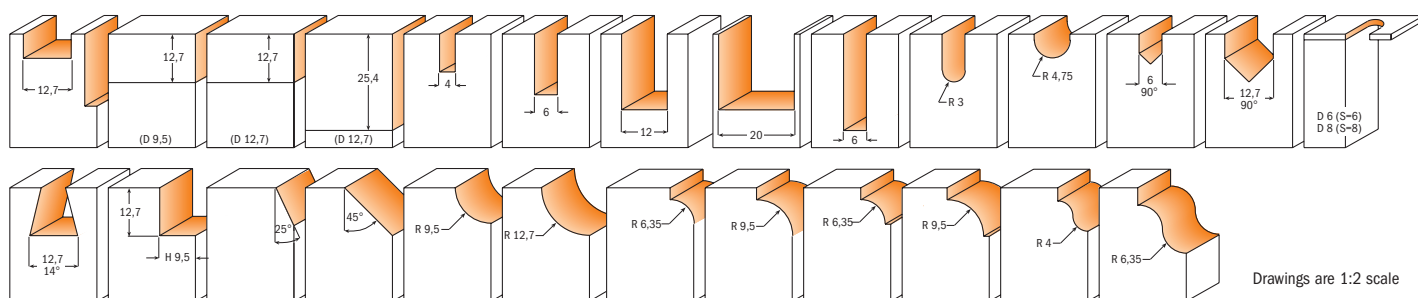

DESCRIPTION	ORDER NO.	ORDER NO.
	Shank Ø 6mm	Shank Ø 8mm
26 piece router bit set	<b>700.003.00</b>	<b>900.003.00</b>

**15 piece router bit set**

**7/8/900.001**



Our beautiful sets are the perfect companion for the CMT craftsman. The 15 piece router bit set offers a selection of both straight and profile bits, beautifully organized and ready to use. A handsome addition to any woodworker's collection; each set includes bits made of Fatigue Proof® steel and micrograin carbide; coated with orange non-stick PTFE. Can be safely stored in a hardwood snap lock case.

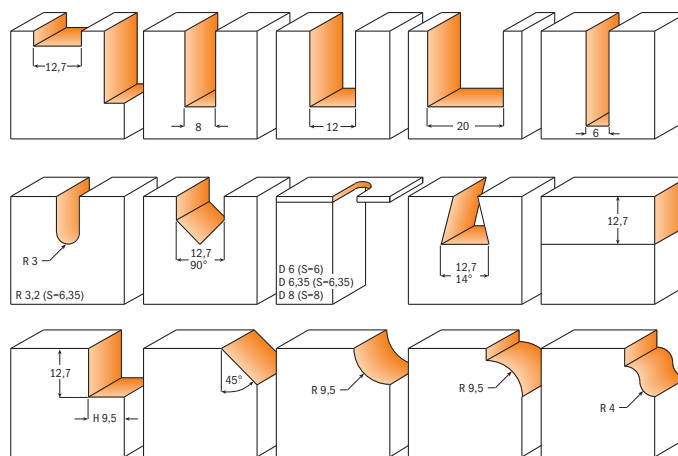

DESCRIPTION	ORDER NO.	ORDER NO.	ORDER NO.
	Shank Ø 6mm	Shank Ø 6,35mm	Shank Ø 8mm
15 piece router bit set	<b>700.001.00</b>	<b>800.001.00</b>	<b>900.001.00</b>

## 5 piece straight bit set



Our beautiful sets are the perfect companion for the CMT craftsman. We offer three 5 piece sets - choose from our complete collection of straight bits or a selection of the most popular profile router bits. Each set includes bits made of Fatigue Proof® steel and micrograin carbide; coated with orange non-stick PTFE. Safely stored in a solid plastic box suitable to fit in your display cabinet.

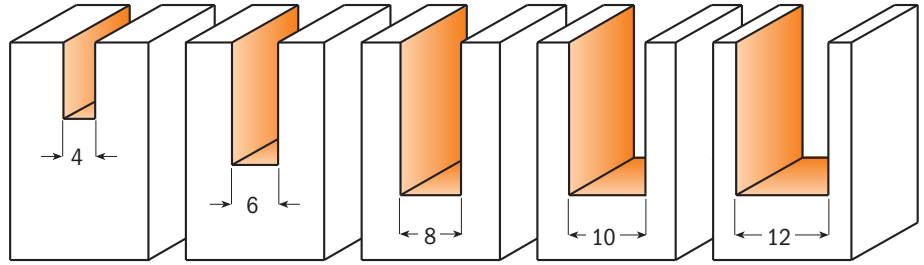

Drawings are 1:1 scale

DESCRIPTION	ORDER NO. Shank Ø 6mm	ORDER NO. Shank Ø 6,35mm	ORDER NO. Shank Ø 8mm
5 piece straight bit set	<b>700.005.01</b>	<b>800.005.01</b>	<b>900.005.01</b>

## 5 piece profile bit set

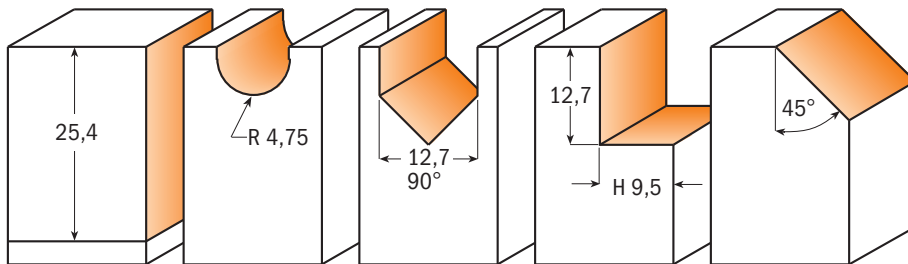

Drawings are 1:1 scale

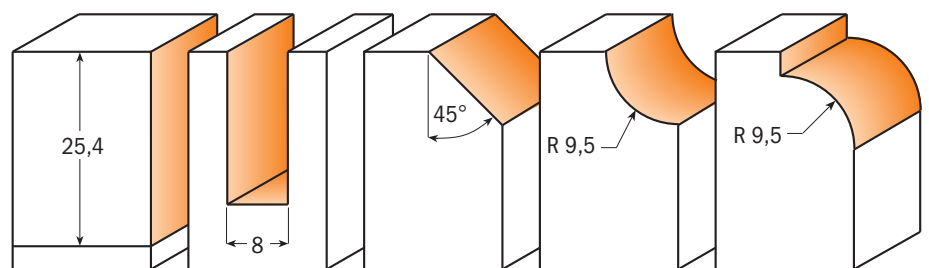

Drawings are 1:1 scale

DESCRIPTION	ORDER NO. Shank Ø 6mm	ORDER NO. Shank Ø 6,35mm	ORDER NO. Shank Ø 8mm
5 piece profile bit set	<b>700.005.02</b>		<b>900.005.02</b>
5 piece profile bit set	<b>700.005.03</b>		<b>900.005.03</b>

**600.005.01**



This beautiful set is the perfect companion for the CMT craftsman. We offer the most popular 5 bits with knives and all necessary spare knives and torx key. They are perfect to work all materials like solid wood, wood and composites, plastic and laminated with hand or cnc router.

**10 spare knives and 2 torx keys included**

Set contains		D Cutting diameter mm	I Cutting length mm	Spare knives	Spare Bearing	ORDER NO. Shank Ø 8mm
Straight router bit with knife	20x4,1x1,1	8	20	790.200.01		<b>651.080.11</b>
Straight router bit with knife	30x5,5x1,1	10	30	790.300.01		<b>651.100.11</b>
Straight router bit with knife	30x5,5x1,1	12	30	790.300.01		<b>651.120.11</b>
Straight router bit with knife	30x5,5x1,1	14	30	790.300.01		<b>651.140.11</b>
Flush trim bit with knife	30x12x1,5	19	30	790.300.00	791.007.00	<b>657.191.11</b>

**5 piece spiral bit set**

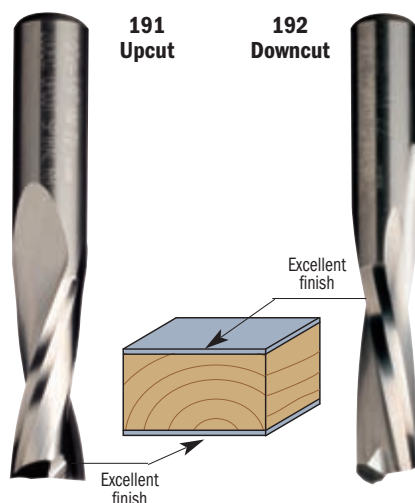

A new set of solid carbide spiral bits in super micrograin carbide of superior quality with upcut and downcut sharpening available in the following diameters: 4-6-8-10-12mm. New super micrograin formula offers extremely sharp and longer lasting cutting edges. Low spiral grind shears material with more efficient chip ejection. The tool works less, runs cooler and out performs the competition. Our new precision machinery was designed and built to CMT spec's. We now manufacture solid carbide spiral bits with the tightest tolerances in the industry. You won't find a better performance in tooling. We recommend use on all soft and hard wood, on plywood, on laminates, MDF and plastic materials, with your CNC or hand router machines due to the 8mm shank.

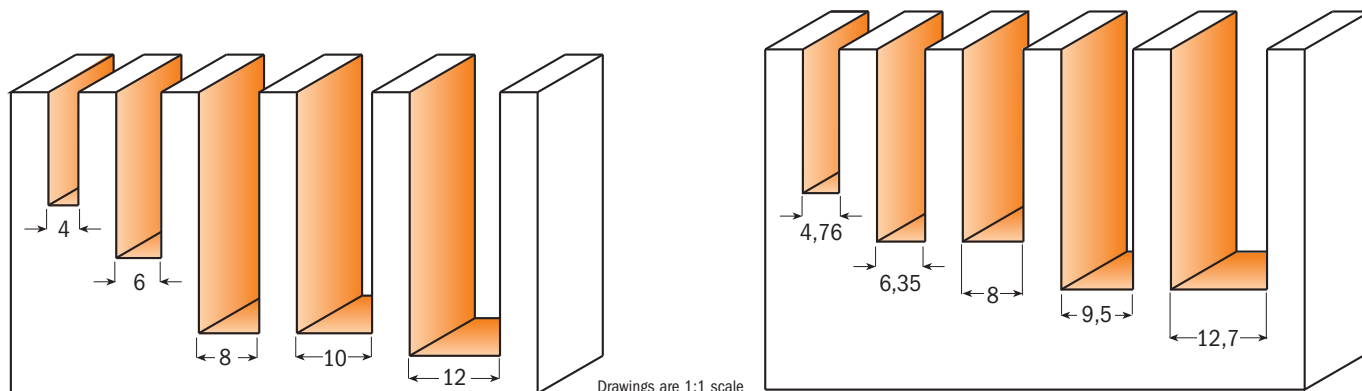

DESCRIPTION		ORDER NO. Shank Ø 8mm	ORDER NO. Shank Ø 6,35-12,7mm
5 piece upcut spiral bit set	(Ø4 - 6 - 8 - 10 - 12mm)	<b>191.000.01</b>	
5 piece downcut spiral bit set	(Ø4 - 6 - 8 - 10 - 12mm)	<b>192.000.01</b>	
5 piece upcut spiral bit set	(Ø4,76 - 6,35 - 8 - 9,5 - 12,7mm)		<b>191.000.02</b>
5 piece downcut spiral bit set	(Ø4,76 - 6,35 - 8 - 9,5 - 12,7mm)		<b>192.000.02</b>



## 8 piece dovetail and straight bit sets

**800.500/501**



Perfect for the craftsman with a creative flair. The CMT 8 piece dovetail and straight bits set has all the most frequently used bit for constructing boxes, making creative joinery and a wide range of other projects. Safely packaged in a hardwood box to give you easier organization and unlimited possibilities; these bits suit most popular jigs. Complete, economical set to fit Leigh jig systems.

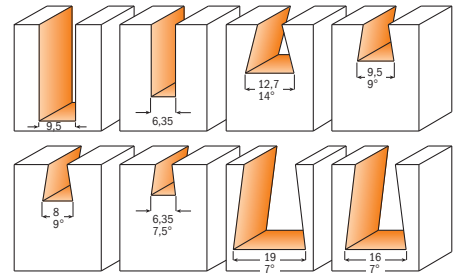

Drawings are 1:2 scale

DESCRIPTION	ORDER NO. Shank Ø 6,35mm	ORDER NO. Shank Ø 12,7mm
8 piece dovetail and straight bit set	<b>800.500.11</b>	<b>800.501.11</b>

## 13 piece dovetail and straight bit sets

**800.519**



Perfect for the craftsman with a creative flair. The CMT 13 piece dovetail and straight bit set has all the most frequently used bits for constructing boxes, making creative joinery and a wide range of other projects. Safely packaged in a hardwood box to give you easier organization and unlimited possibilities; these bits suit most popular jigs. Complete, economical set to fit Leigh jig systems.

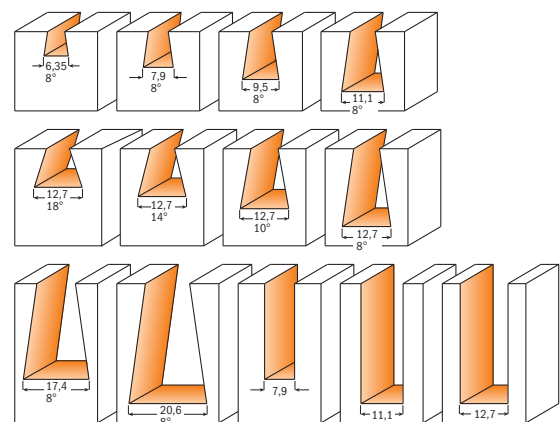

Drawings are 1:2 scale

DESCRIPTION	ORDER NO. Shank Ø 6,35-12,7mm
13 piece dovetail and straight bit set	<b>800.519.11</b>

**800.503**



These boxed sets are as handsome to look at as they are convenient to use. 12 of our most frequently used bits with 6,35mm shanks have been specifically co-ordinated so you always have exactly what you need on hand. Organized in a specially designed Italian hardwood case for safe storage when not in use.

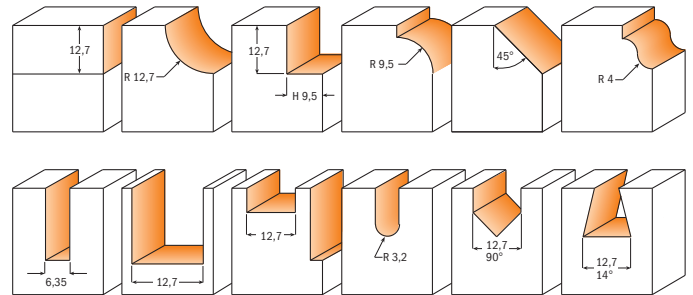

Drawings are 1:2 scale

**DESCRIPTION**

**ORDER NO.**  
Shank  
Ø 6,35mm

12 piece set with wooden case

**800.503.11**

**13 piece set with wooden case**

**800.505**



These boxed sets are as handsome to look at as they are convenient to use. 13 of our most frequently used bits with 12,7mm shanks have been specifically co-ordinated so you always have exactly what you need on hand. Organized in a specially designed Italian hardwood case for safe storage when not in use.

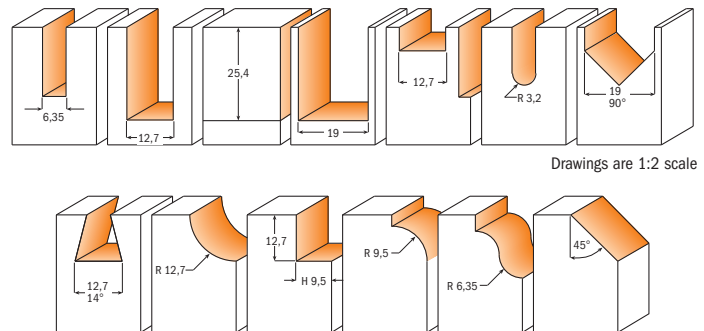

Drawings are 1:2 scale

**DESCRIPTION**

**ORDER NO.**  
Shank  
Ø 12,7mm

13 piece set with wooden case

**800.505.11**

**6 piece profile bit set with wooden case**

**800.504**

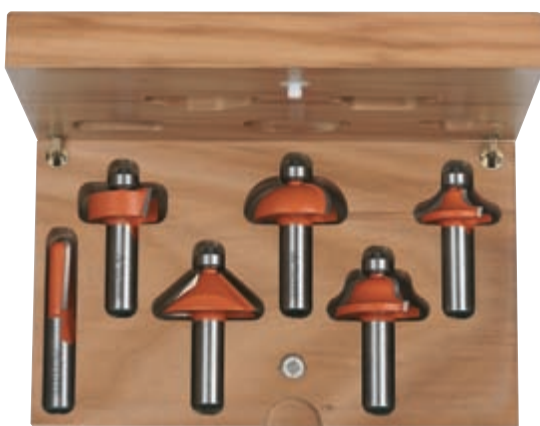

These boxed sets are as handsome to look at as they are convenient to use. 6 of our most frequently used bits with 12,7mm shanks have been specifically co-ordinated so you always have exactly what you need on hand. Organized in a specially designed Italian hardwood case for safe storage when not in use.

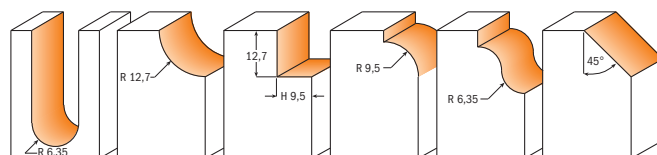

Drawings are 1:2 scale

**DESCRIPTION**

**ORDER NO.**  
Shank  
Ø 12,7mm

6 piece profile bit set

**800.504.11**

800.527



The new CMT three-piece set simplifies door construction, making it easy as 1, 2, 3!  
It is not the only advantage in fact this is a multi functional set for door makers and furniture makers building entry doors, passage doors and any furniture tenons. In fact the included tenon cutter produces a beefy 27mm long tenon. Coupled with the cope cutter, you can produce long and strong tenons with minimum set up. As an extra bonus the tenon cutter can be used for furniture making work that requires any tenon from 4,7mm to 16mm thick.

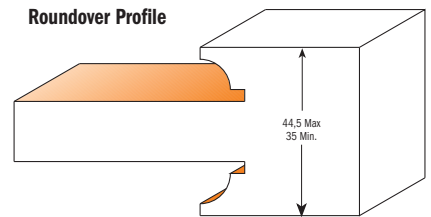
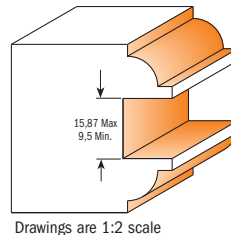

Drawings are 1:2 scale

DESCRIPTION

3 piece set with wooden case

ORDER NO.  
Shank  
Ø 12,7mm

800.527.11

Entry & Interior door construction - Easy as 1, 2, 3!

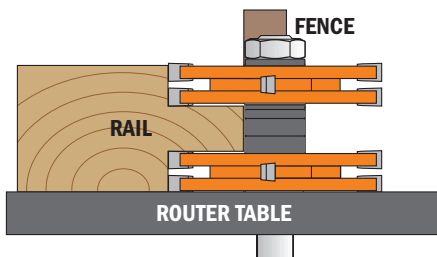

Step 1. Cut the tenon in the rails

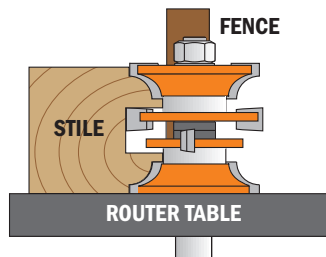

Step 2. Cut the groove and door profile in all the pieces.

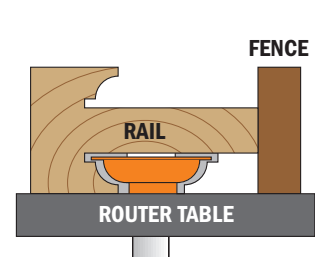

Step 3. Undercut the tenons to cope the ends of the rails.

Tenon cutting router

800.627

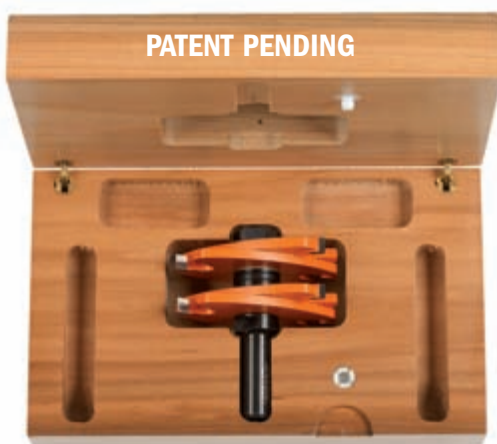

**Cut perfectly fitting tenons, every time.** If you've struggled cutting tenons that fit, here's the perfect solution for precise tenons. CMT's new tenon cutting router bit will produce perfectly fitting tenons in every board you cut, even if the boards vary slightly in thickness. Simply set the distance between the cutters using the included spacers, and you can easily cut tenons from 4,76mm to 9,5mm thick, up to 27mm long. This simple-to-use router bit takes the mystery out of achieving the excellent tenon-to-mortise fit required for high quality joinery.

**Safety Precautions:** Maximum speed: 12,000 rpm.

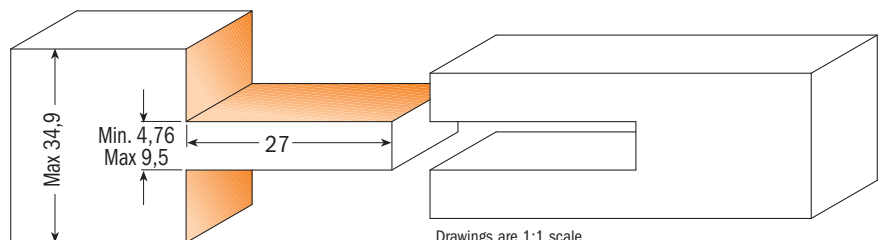

Drawings are 1:1 scale

Tenon Cutting	No. Spacer		
	6,35	3,2	1,6
4,76	1	0	0
6,35	1	0	1
8	1	1	0
9,5	1	1	1

I	D	H	ORDER NO.
Cutting length	Cutting diam.	Cutting depth	Shank
mm	mm	mm	Ø 12,7mm
34,9	75	27	800.627.11

Spare parts:

824.134.00	Ø12,7mm shank arbor	822.020.11	Slot cutter 6,35mm	541.521.00	1,6mm spacer
541.522.00	3,2mm spacer	541.523.00	6,2mm spacer	541.513.00	0,1mm spacer
541.520.00	0,3mm spacer	990.022.00	Nut for arbor, M12x1,25mm		



**8/900.525**



This three-piece set allows you to make true divided light doors for fine furniture and cabinets. The set consists of a sticking bit to cut the decorative ovolo profile on the frame edges, a cope bit which shapes the mating profile on the ends of the stock, and a rabbeting bit for cutting the recess for the glass. Because the bits have guide bearings you can also create arched or curved frames.

The unique design of the cope bit allows you to use full-length tenons to create strong, authentic mortise-and-tenon joinery. As the stock is coped, the tenon passes over the bit. The set is designed for 22,2mm wide bars such as those on a corner cupboard door.

Available in 8 and 12,7mm shanks. Instructions included.

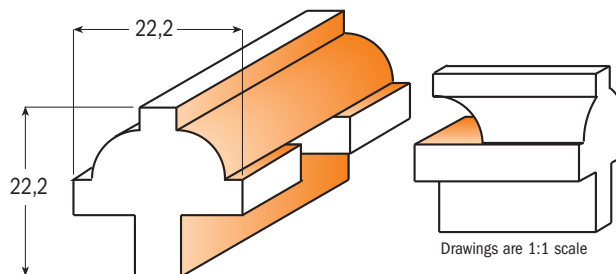

DESCRIPTION	ORDER NO.	ORDER NO.
	Shank Ø 8mm	Shank Ø 12,7mm
“Lonnie Bird” divided light door set	<b>900.025.11</b>	<b>800.525.11</b>

**The glass panel set**

**8/955.803**



Another innovative CMT product this unique stile and rail set allows you to easily produce glass panel doors utilizing a rubber panel retainer to secure the glass in a 3,2mm slot cut into the frames. This set works the same as our other stile and rail sets but leaves you with a square rabbet on the inside of your door for installing the glass panel.

Machine all piece face down.

After machining the cope and pattern cuts use the 3,2mm slot cutter to cut the groove for the rubber panel retainer. The edge of the pattern cut will ride on the guide bearing of the slot cutter bit. When you cut the slot in the rails you can cut the slot the full length of the stock. When you cut the slot in the stiles you need to set up reference points to stop and start the cuts so they are hidden from view on the top and bottom of the doors.

Available in 12 and 12,7mm shanks.

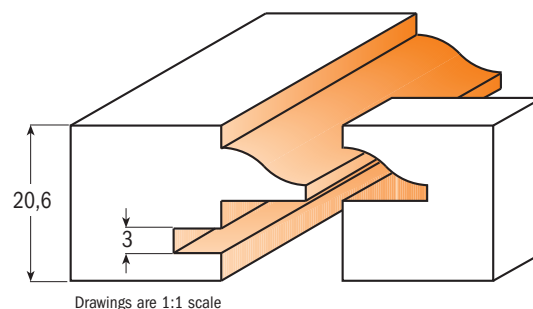
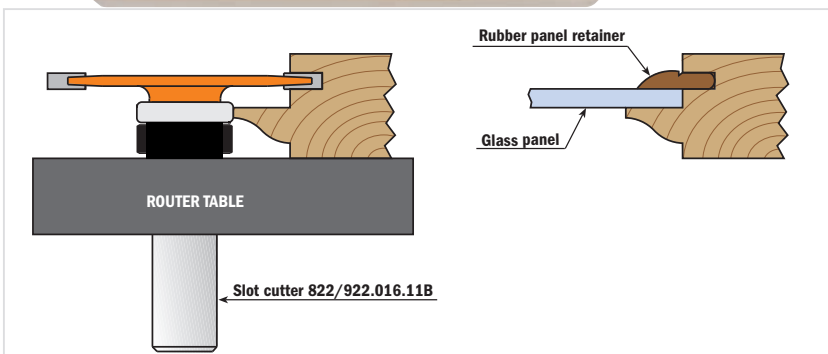

DESCRIPTION	ORDER NO.	ORDER NO.
	Shank Ø 12mm	Shank Ø 12,7mm
The glass panel set	<b>955.803.11</b>	<b>855.803.11</b>



Our sets aren't just a random selection of odds and ends packaged in a box to look nice - the CMT complete kitchen set is a professional drawer and door makers kit. We give you three sets to choose from for the profiles you prefer. Each set includes your choice of raised panel bit and rail & stile bit plus a glue joint and drawer lock bit. See illustrations below for complete profile options.

**800-900.509.11**

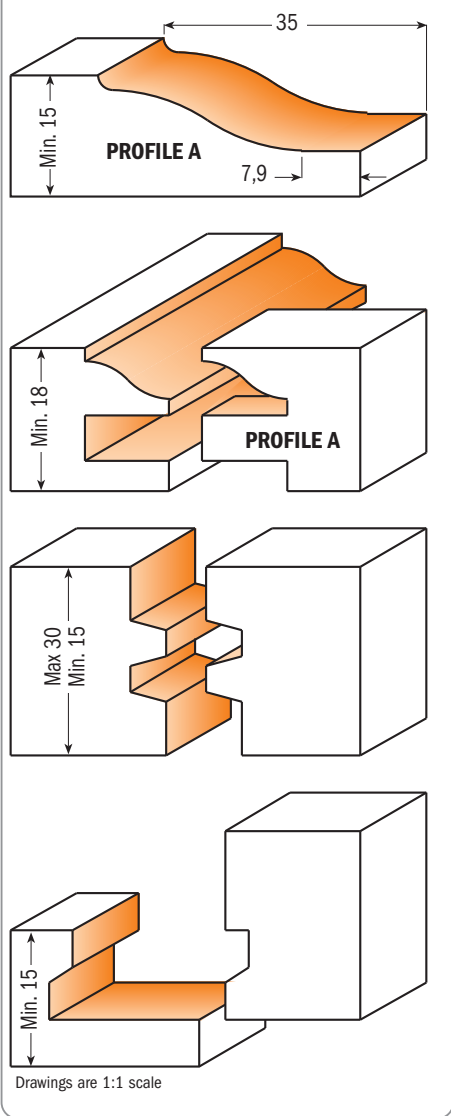

Drawings are 1:1 scale

**800-900.510.11**

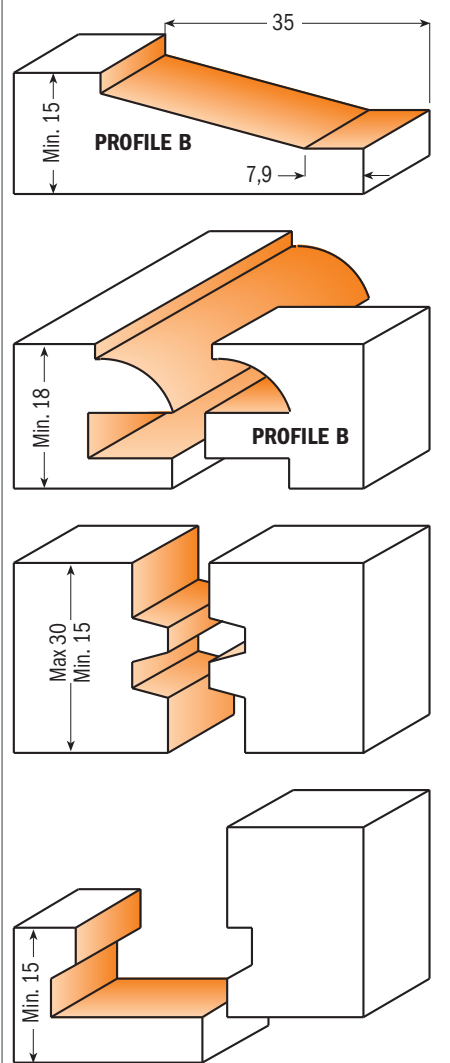

Drawings are 1:1 scale

**800-900.511.11**

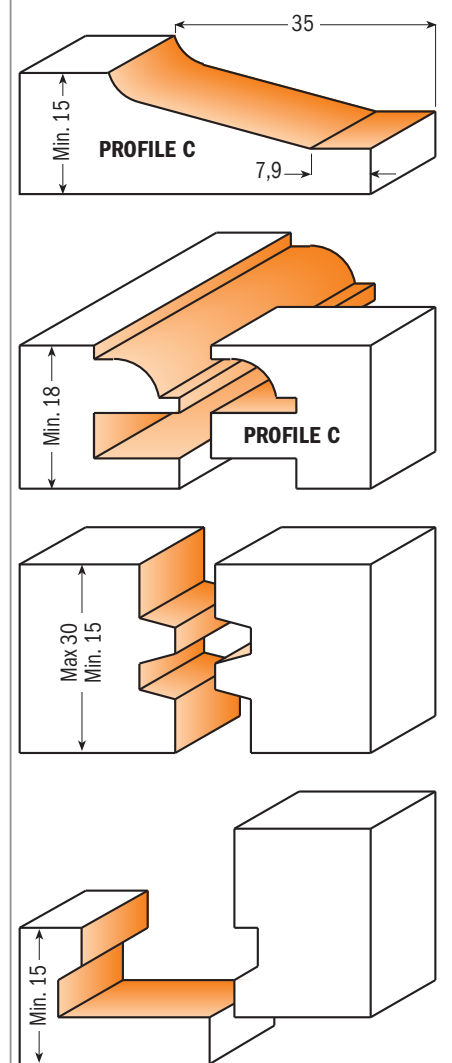

Drawings are 1:1 scale

DESCRIPTION	ORDER NO. Shank Ø 12mm	ORDER NO. Shank Ø 12,7mm
CMT's complete kitchen set - Profile A (5 pcs. HW)	<b>900.509.11</b>	<b>800.509.11</b>
CMT's complete kitchen set - Profile B (5 pcs. HW)	<b>900.510.11</b>	<b>800.510.11</b>
CMT's complete kitchen set - Profile C (5 pcs. HW)	<b>900.511.11</b>	<b>800.511.11</b>



Open some new doors with CMT. Our 3-piece kitchen set includes a Rail & Stile bit couple and a Raised Panel bit with your choice of 3 profiles to make panel door construction easy and economical. Each bit is made from bar stock steel and the highest quality tungsten carbide; and exclusively surface treated with our trademark orange non-stick PTFE coating. And it all comes safely organized in our protective hardwood case so you'll probably have the nicest looking toolbox around. See profile options below.

**800-900.513.11**

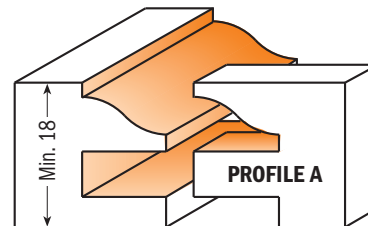
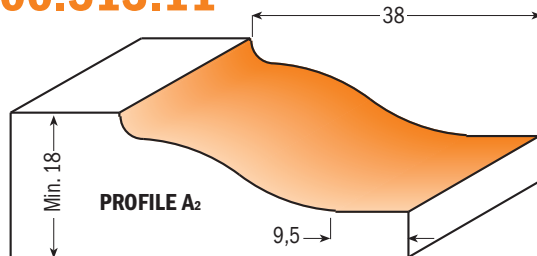

Drawings are 1:1 scale

**800-900.512.11**

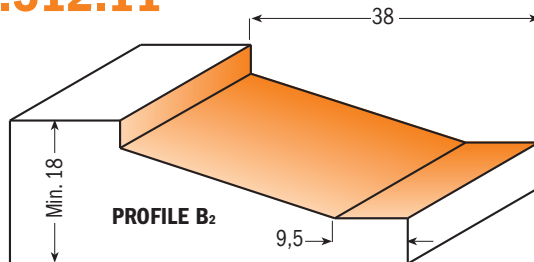

Drawings are 1:1 scale

**800-900.514.11**

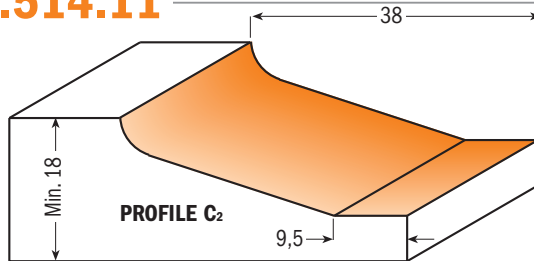

Drawings are 1:1 scale

**800-900.516.11**

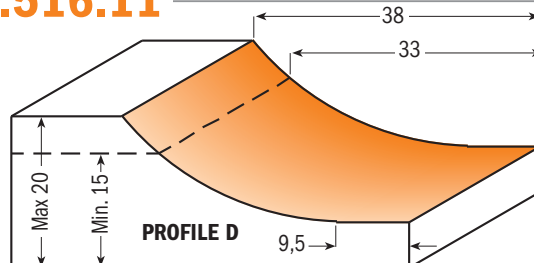

Drawings are 1:1 scale

DESCRIPTION	ORDER NO. Shank Ø 12mm	ORDER NO. Shank Ø 12,7mm
3 piece kitchen set - Profile A <sub>2</sub> HW	<b>900.513.11</b>	<b>800.513.11</b>
3 piece kitchen set - Profile B <sub>2</sub> HW	<b>900.512.11</b>	<b>800.512.11</b>
3 piece kitchen set - Profile C <sub>2</sub> HW	<b>900.514.11</b>	<b>800.514.11</b>
3 piece kitchen set - Profile D HW	<b>900.516.11</b>	<b>800.516.11</b>



**800.515 - 800.520**



Make straight and arched raised panels that rival those made with expensive machinery - all you need is your router table and a Cabinetmaking Set. Now available with Raised Panel bits in two

different profiles, this set features six router bits designed expressly for making arched raised panel doors and professional drawer fronts. The set includes:

**OGEE RAIL AND STILE SET** Two perfectly matched bits eliminate the frustration and time-consuming set-up of reversible cutters. The stile cutter also features a shear angle to produce superior cuts.

**RAISED PANEL BIT WITH BACK-CUTTER** This 88,9mm diameter bit has a back-cutter which allows milling of both the front and back of the panel in the same cut. An additional 31mm diameter bearing promotes safety by allowing you to take two shallow passes.

**SUPER-DUTY FLUSH TRIM BIT** The 19mm cutting diameter gives a superior cut with minimal chipping, even on end grain.

**OGEE DOOR EDGE BIT** A subtle cove followed by a small roundover adds an elegant touch to the door edge.

**DRAWER FRONT BIT** This unique bit makes a mini-raised panel cut on the outside edges of the drawer fronts.

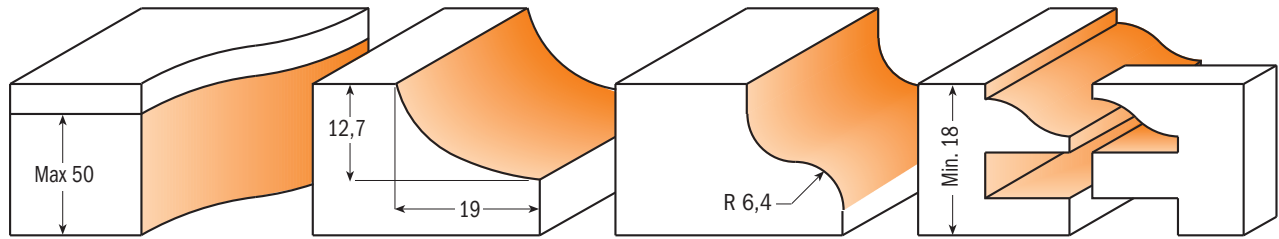

Raised panel bit included in the set 800.515.11

Raised panel bit included in the set 800.520.11

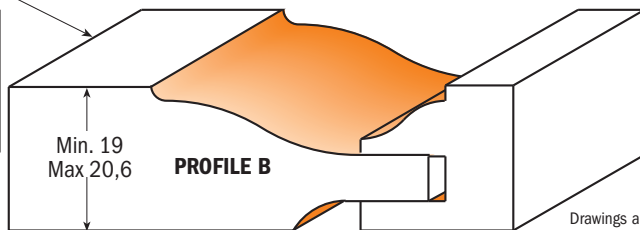
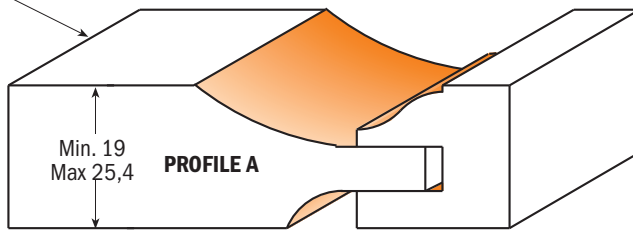

Drawings are 1:1 scale

DESCRIPTION	ORDER NO. Shank Ø 12,7mm
The Cabinetmaking set - Profile A (6 pcs. HW)	<b>800.515.11</b>
The Cabinetmaking set - Profile B (6 pcs. HW)	<b>800.520.11</b>

**8/900.517-521**



Making raised panels is easier than ever before with this new three-piece set. The ogee rail and stile bits are made to exact specifications to match perfectly. The stile cutter has a shear angle to produce superior cuts with minimal splintering. The 89mm diameter raised panel bit has a cove profile and a back-cutter which allows milling of the front and back of the panel in the same pass.

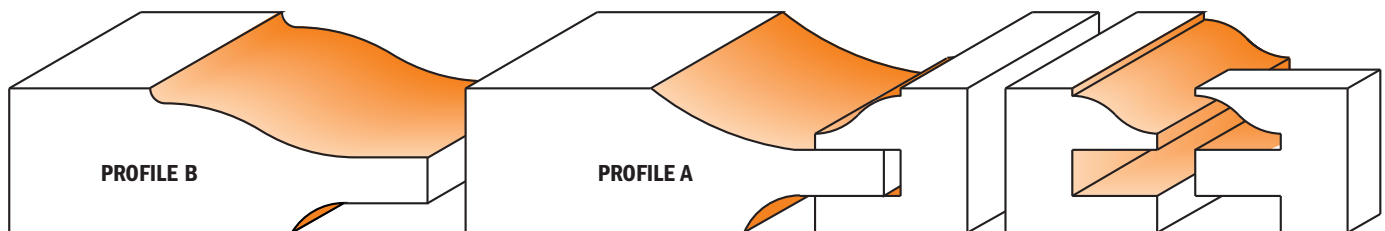

Drawings are 1:1 scale

DESCRIPTION	ORDER NO. Shank Ø 12mm	ORDER NO. Shank Ø 12,7mm
The Raised panel set - Profile A (3 pcs. HW)	<b>900.517.11</b>	<b>800.517.11</b>
The Raised panel set - Profile B (3 pcs. HW)	<b>900.521.11</b>	<b>800.521.11</b>

8/900.518-522



With any project, it's the detail that makes the difference. That is exactly why we have teamed up again with to bring another innovation to the market. The new Junior Raised Panel Set is a modification of the original cabinet door set - made on a smaller scale with enormous possibilities. The Junior Set lets you make frame and panel details as small as 70mm square in material as thin as 11mm and up to 17,5mm thick.

These delicate looking panels are only the beginning and enhance a variety of projects. Make templates and add interesting arches to your work. But don't be fooled by their appearance; they produce extremely strong joints and add integrity to any creation. Jewelry boxes, humidors, clock cases, even library panels and coffered ceilings will come alive with the beauty that frame and panel craftsmanship provides. The Junior Set includes the Raised Panel Bit with back-cutter and the matched Ogee Rail & Stile pair, packaged in a protective hardwood case.

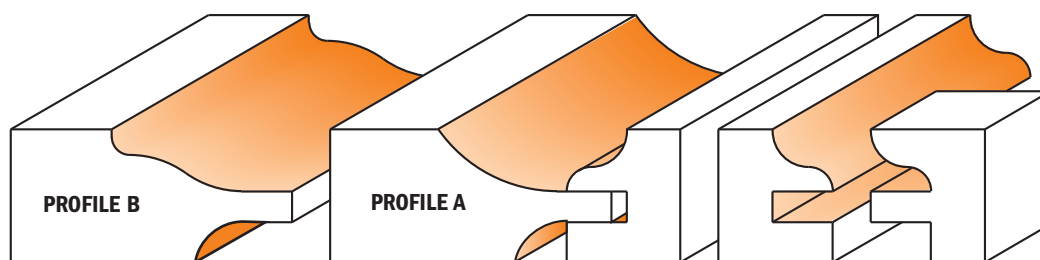

Drawings are 1:1 scale

DESCRIPTION	ORDER NO. Shank Ø 12mm	ORDER NO. Shank Ø 12,7mm
The junior raised panel set - Profile A (3 pcs. HW)	900.518.11	800.518.11
The junior raised panel set - Profile B (3 pcs. HW)	900.522.11	800.522.11

**“Lonnie Bird” small arch door set**

8/900.524



This three-piece set will produce beautiful raised panel doors with a classic, diminutive beveled profile. Designed for use in fine furniture making, this set includes two matched cope and stick bits for producing frames in 15,8mm to 19mm thick material. The stick bit shapes a decorative 4,7 mm thumbnail molding along the edge of the frame.

The panel making bit is designed for 12,7mm thick material. All bits are equipped with guide bearings for shaping curved work such as the small arched panel doors seen on secretaries and corner cabinetry. This set also produces panels for small chests and other cabinetry.

The raised panel bit alone makes a nice lid for small boxes or drawer fronts. Available in 8 and 12,7mm shanks. Instructions included.

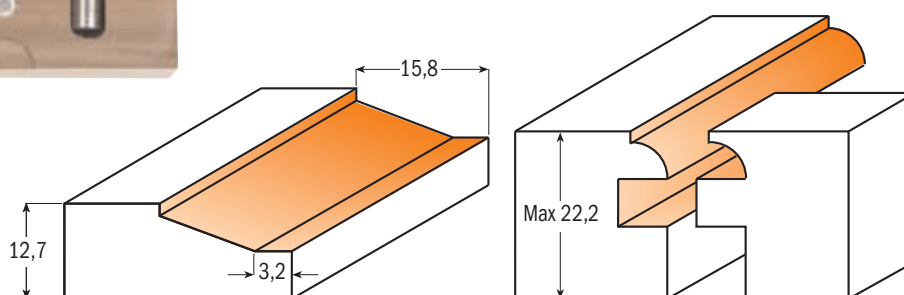

Drawings are 1:1 scale

DESCRIPTION	ORDER NO. Shank Ø 8mm	ORDER NO. Shank Ø 12,7mm
“Lonnie Bird” small arch door set (3 pcs. HW)	900.024.11	800.524.11

8/923.001



Create slots, grooves and rabbets in all materials using the adjustable CMT slot cutter set. See chart below for all applications and correct cutter combinations. Ideal for biscuit joints and milling perfect tongue and groove joints. **The set includes 4 different bearings which allow cutting depth of 7,95 - 9,55 - 12,8 and 14,3mm.**

**Safety tips:** Never use the slot cutter set without shims between the cutters. The distance between the cutters can vary from 1mm to 1,7mm. A shim must also be positioned between the ball bearing and the cutters.

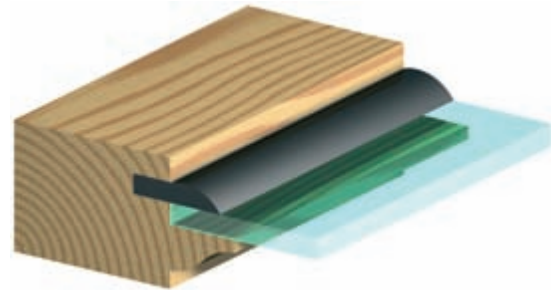

Assembly illustration

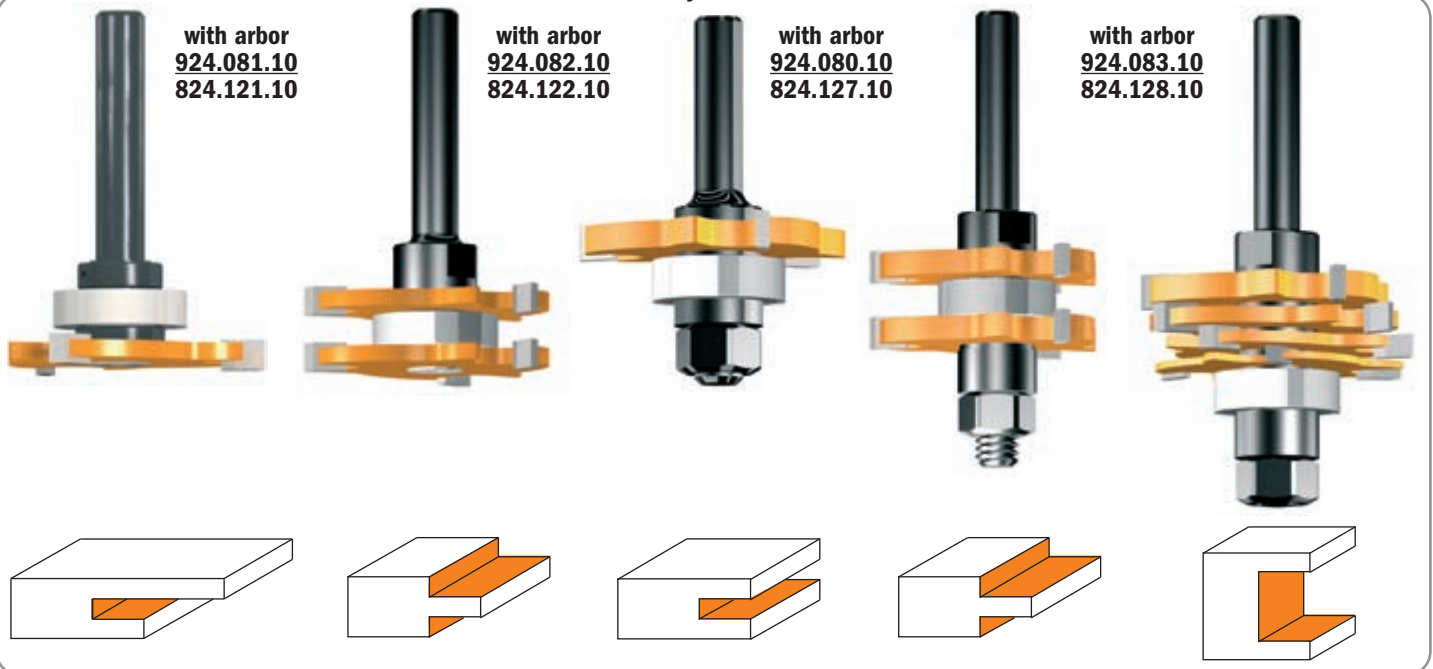

CONTENUTO DEL SET	ORDER NO. 923.001.11		ORDER NO. 823.001.11	
	Q.ty	Shank Ø 8mm	Q.ty	Shank Ø 12,7mm
Slot cutter 1,6mm (1/16")			1	822.316.11
Slot cutter 2mm	1	822.320.11		
Slot cutter 3mm with 45° bore	1	823.330.11		
Slot cutter 3,2mm (1/8") with 45° bore			1	823.332.11
Slot cutter 4mm with 45° bore	1	823.340.11	1	823.340.11
Slot cutter 4,8mm (3/16")			1	822.348.11
Slot cutter 5mm with 45° bore	3	823.350.11		
Slot cutter 6mm	1	822.360.11		
Slot cutter 6,4mm (1/4") with 45° bore			3	823.364.11
Slot cutter arbor with bearing Ø22mm	1	924.080.10	1	824.127.10
Slot cutter arbor with bearing Ø22mm	1	924.081.10	1	824.121.10
Slot cutter arbor with bearing Ø22mm	1	924.082.10	1	824.122.10
Slot cutter arbor with bearing Ø22mm long series	1	924.083.10	1	824.128.10
Ø31,7mm bearing	1	791.033.00	1	791.033.00
Ø28,5mm bearing	1	791.030.00	1	791.030.00
Ø19mm bearing	1	791.034.00	1	791.034.00
Hex key 3mm	1	991.067.00	1	991.067.00



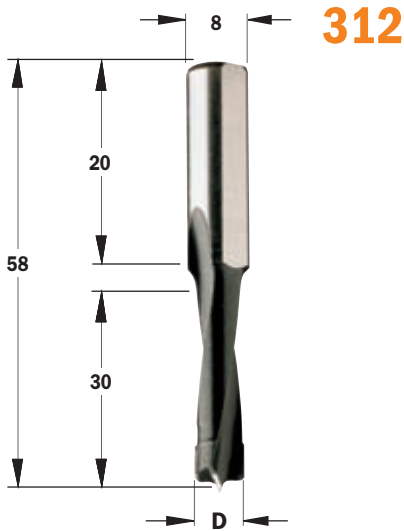

These drill bits are made with high-strength steel in order to work with high speed rotation. They are perfect to bore all materials like solid wood, wood and composites, plastic and laminated with **hand or cnc router and MAFELL® machine model DD40.**

D Cutting diameter mm			ORDER NO. Shank Ø 8mm
5			<b>312.050.11</b>
6			<b>312.060.11</b>
8			<b>312.080.11</b>
10			<b>312.100.11</b>
12			<b>312.120.11</b>
14			<b>312.140.11</b>
16			<b>312.160.11</b>

**TECHNICAL DETAILS:**

- Super strength steel
- Spiral portion coated with black PT.FE.
- HW precision balanced centre point
- 2 precision ground HW cutting edges [Z2]
- 2 spiral flute
- Right-hand rotation (RH)

**Boring bits with parallel shank**



These boring bits are made with high-strength steel in order to work with high speed rotation. They are perfect to bore all materials like solid wood, wood and composites, plastic and laminated **with hand or cnc router.**

D Cutting diameter mm	L Overall length mm	ORDER NO. Shank Ø 8mm
25	60	<b>391.250.11</b>
26	60	<b>391.260.11</b>
30	60	<b>391.300.11</b>
35	60	<b>391.350.11</b>

D Cutting diameter mm	L Overall length mm	ORDER NO. Shank Ø 9,5mm	ORDER NO. Shank Ø 12,7mm
35	66	<b>391.352.11</b>	<b>391.351.11</b>

**TECHNICAL DETAILS:**

- Super strength steel
- Spiral portion coated with black PT.FE.
- HW precision balanced centre point
- 2 precision ground HW cutting edges [Z2]
- Right-hand rotation (RH)

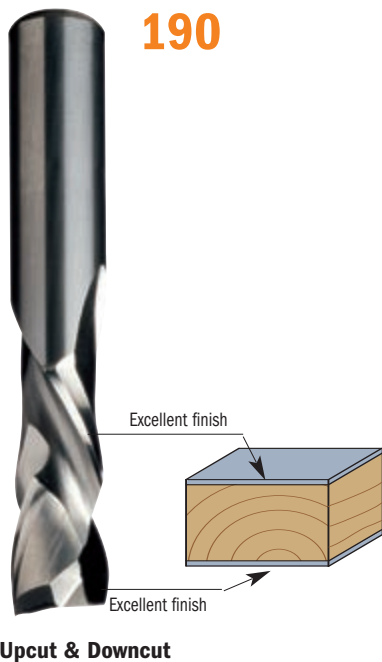

**Upcut & Downcut**

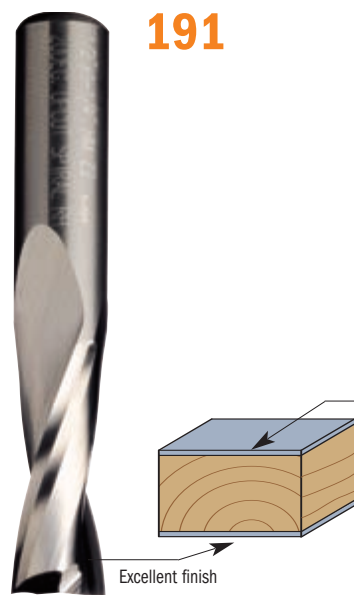

**Upcut**



**Downcut**



Due to their spiral cutting edge which stays in continuous contact with the workpiece, these bits give a smooth, chatter-free cutting action, unlike conventional bits which have intermittent contact with the workpiece. Unsurpassed for cleaner cuts in ordinary or difficult materials, softwood, hardwood, plywood, composites etc. This new range of spiral bits with 6, 8, 12mm and 6,35 and 12,7mm shanks allow them to be used with C.N.C. router and hand-routers.

**Test check yourselves the extraordinary quality-price ratio of these bits!**

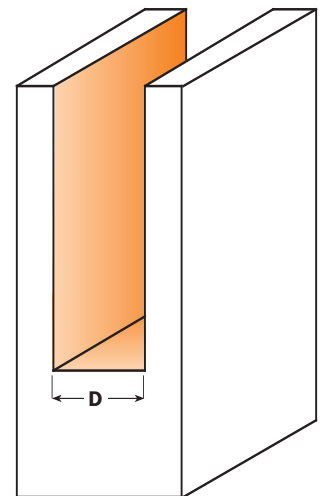

Drawing are 1:1 scale

**... Z2+2 upcut & downcut spiral**

**190**

D Cutting diameter		I Cutting length	L Overall length	ORDER NO. Shank Ø 8mm	ORDER NO. Shank Ø 9,5mm	ORDER NO. Shank Ø 10mm	ORDER NO. Shank Ø 12mm	ORDER NO. Shank Ø 12,7mm
mm	inches	mm	mm					
8		32	80	<b>190.080.11</b>				
9,53	3/8	31,75	76,2		<b>190.504.11</b>			
10		32	80			<b>190.100.11</b>		
12		42	90				<b>190.120.11</b>	
12,7	1/2	25,4	76,2					<b>190.505.11</b>
12,7	1/2	28,6	76,2					<b>190.506.11</b>
12,7	1/2	34,9	88,9					<b>190.507.11</b>
12,7	1/2	41,3	101,6					<b>190.508.11</b>

**... Z2 upcut spiral**
**191**

D Cutting diameter		I Cutting length	L Overall length	ORDER NO. Shank Ø 6mm	ORDER NO. Shank Ø 6,35mm	ORDER NO. Shank Ø 8mm	ORDER NO. Shank Ø 12mm	ORDER NO. Shank Ø 12,7mm
mm	inches	mm	mm					
3		12	60	<b>191.630.11</b>		<b>191.830.11</b>		
3,18	1/8	12,7	50,8		<b>191.001.11</b>			
3,5		12	60	<b>191.635.11</b>				
3,97	5/32	12,7	50,8		<b>191.003.11</b>			
4		15	60	<b>191.640.11</b>		<b>191.840.11</b>		
4,76	3/16	19,05	50,8		<b>191.005.11</b>			
5		17	60	<b>191.650.11</b>		<b>191.850.11</b>		
6		27	70	<b>191.060.11</b>		<b>191.860.11</b>		
6,35	1/4	19,05	50,8		<b>191.007.11</b>			
6,35	1/4	25,4	63,5		<b>191.008.11</b>			
7		32	80			<b>191.870.11</b>		
7,94	5/16	25,4	76,2					<b>191.501.11</b>
8		22	70			<b>191.080.11</b>		
8		32	80			<b>191.081.11</b>		
8		42	90			<b>191.082.11</b>		
9		32	80				<b>191.890.11</b>	
9,53	3/8	31,75	76,2					<b>191.503.11</b>
10		32	80			<b>191.800.11</b>	<b>191.900.11</b>	
10		42	90				<b>191.901.11</b>	
12		35	80			<b>191.820.11</b>	<b>191.120.11</b>	
12		42	90				<b>191.121.11</b>	
12		52	100				<b>191.122.11</b>	
12,7	1/2	31,75	76,2					<b>191.505.11</b>
12,7	1/2	38,1	88,9					<b>191.506.11</b>
12,7	1/2	50,8	101,6					<b>191.507.11</b>
<b>10 pcs. in masterpack</b>					<b>191.008.11-X10</b>			

**... Z2 downcut spiral**
**192**

D Cutting diameter		I Cutting length	L Overall length	ORDER NO. Shank Ø 6mm	ORDER NO. Shank Ø 6,35mm	ORDER NO. Shank Ø 8mm	ORDER NO. Shank Ø 12mm	ORDER NO. Shank Ø 12,7mm
mm	inches	mm	mm					
3		12	60	<b>192.630.11</b>		<b>192.830.11</b>		
3,18	1/8	12,7	50,8		<b>192.001.11</b>			
3,97	5/32	12,7	50,8		<b>192.003.11</b>			
4		15	60	<b>192.640.11</b>		<b>192.840.11</b>		
4,76	3/16	19,05	50,8		<b>192.005.11</b>			
5		17	60	<b>192.650.11</b>		<b>192.850.11</b>		
6		22	70	<b>192.060.11</b>		<b>192.860.11</b>		
6,35	1/4	19,05	50,8		<b>192.007.11</b>			
6,35	1/4	25,4	63,5		<b>192.008.11</b>			
7,94	5/16	25,4	76,2					<b>192.501.11</b>
8		22	70			<b>192.080.11</b>		
8		32	80			<b>192.081.11</b>		
8		42	90			<b>192.082.11</b>		
9,53	3/8	31,75	76,2					<b>192.503.11</b>
10		32	80			<b>192.800.11</b>	<b>192.900.11</b>	
12		35	80			<b>192.820.11</b>	<b>192.120.11</b>	
12,7	1/2	31,75	76,2					<b>192.505.11</b>
12,7	1/2	38,1	88,9					<b>192.506.11</b>
12,7	1/2	50,8	101,6					<b>192.507.11</b>





Our Plywood Groove Bits are designed specifically for routing grooves and dados for joints in plywood. That means they match the true thickness of plywood, producing tight, accurate joints. Use our 18,2mm bit for 19mm plywood, 12,3mm bit for 12,7mm plywood and our 6mm for 6,35mm ply. No gaps or sloppy joints, guaranteed. These money-saving 3-bit sets are available with 12,7mm or 6,35 shanks.

### Example shown in 12,7mm thick plywood

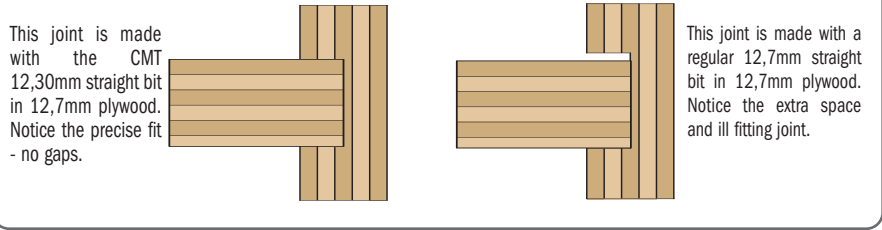

DESCRIPTION	ORDER NO. Shank Ø 6,35mm	ORDER NO. Shank Ø 12,7mm
Plywood groove set (D = Ø6 - 12,3 - 18,2mm)	<b>811.001.11</b>	<b>811.501.11</b>

# Straight bits

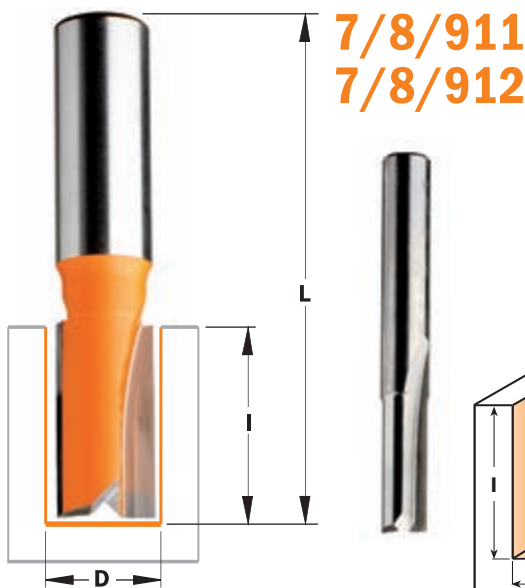

If you are looking to get the most out of your time and money through more efficient production, but want nothing less than a beautiful clean edge on your finished piece, then you definitely must include CMT straight bits in your collection. These razor-sharp, double-faced cutters perfectly synthesize the characteristics and advantages that define quality CMT products. Made of special Fatigue Proof® steel and micrograin carbide, our straight bits can withstand even the heaviest work load and still give you a smooth, precise cut every time. You also get exceptional chip ejection to allow cleaner and more constant cutting.

The surface of all CMT bits is protected with our trademark orange non-stick PTFE to help keep the bit from collecting resin, pitch and other residue.

Every bit is submitted to strict quality tests to guarantee perfect cutting tolerance, balance and concentricity. CMT bits allow production on an industrial scale using a variety of plywoods, composites and natural woods.

CMT produces 91 types of straight bits in a wide range of diameters so you can find exactly what you want.

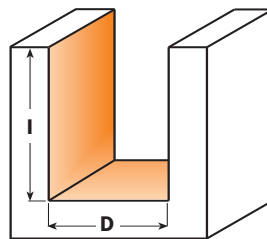

Drawing are 1:1 scale

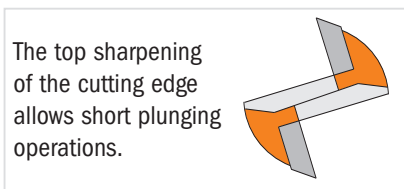

The top sharpening of the cutting edge allows short plunging operations.

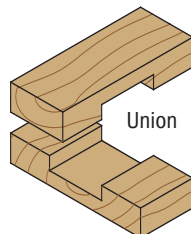

Union

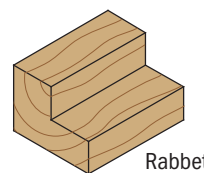

Rabbet

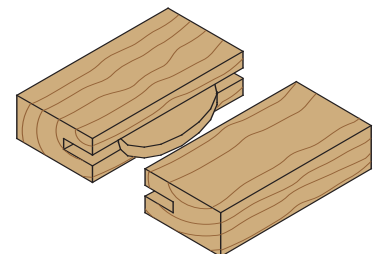

Biscuit joint using bit #7/8/911.040.11

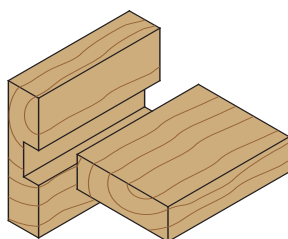

Right-angle joint

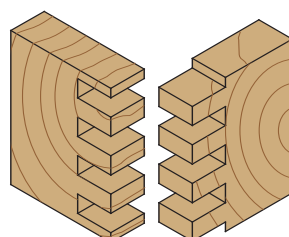

Box joint

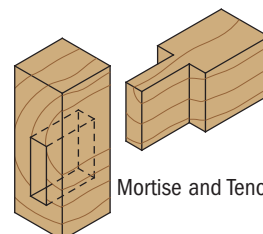

Mortise and Tenon

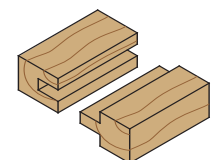

Tongue and groove joint

D Cutting diameter		I Cutting length	L Overall length	ORDER NO. Shank Ø 6mm	ORDER NO. Shank Ø 6,35mm	ORDER NO. Shank Ø 8mm	ORDER NO. Shank Ø 12mm	ORDER NO. Shank Ø 12,7mm
mm	inches	mm	mm					
• 2		4	38	<b>711.020.11</b>	<b>811.020.11</b>			
• 3		8	45	<b>711.030.11</b>	<b>811.030.11</b>	<b>911.030.11</b>		
• 3		8	58,3				<b>911.530.11</b>	
• 3,2	1/8	9,5	45		<b>811.032.11</b>			
• 4		10	58,3				<b>911.540.11</b>	
• 4	5/32	10	45	<b>711.040.11</b>	<b>811.040.11</b>	<b>911.040.11</b>		
• 4,75	3/16	12,7	50,8		<b>811.047.11</b>			
• 5		12	50,8	<b>711.050.11</b>	<b>811.050.11</b>	<b>911.050.11</b>		
• 5		12	58,3				<b>911.550.11</b>	
• 6	15/64	16	50,8	<b>711.060.11</b>	<b>811.060.11</b>	<b>911.060.11</b>		
• 6	15/64	19	60,3					<b>811.560.11</b>
• 6	15/64	19	65				<b>911.560.11</b>	
• 6,35	1/4	19	50,8		<b>811.064.11</b>			
• 6,35	1/4	19	57,2		<b>811.065.11</b>			
• 6,35	1/4	19	60,3					<b>811.564.11</b>
• 7		18	48	<b>711.070.11</b>	<b>811.070.11</b>	<b>911.070.11</b>		
• 7		18	65				<b>911.570.11</b>	
• 7,6		20	51			<b>911.076.11</b>		
• 8	5/16	20	48	<b>711.080.11</b>	<b>811.080.11</b>	<b>911.080.11</b>		
• 8	5/16	25,4	71,5		<b>811.081.11</b>			
• 8	5/16	25,4	70					<b>811.581.11</b>
9		20	48	<b>711.090.11</b>		<b>911.090.11</b>		
9,5	3/8	19	50,8		<b>811.095.11</b>			
9,5	3/8	25,4	63,5		<b>811.096.11</b>			
9,5	3/8	25,4	66,7					<b>811.595.11</b>
10		20	48	<b>711.100.11</b>	<b>811.100.11</b>	<b>911.100.11</b>		
10		25,4	63,5					<b>811.600.11</b>
11		20	48	<b>711.110.11</b>		<b>911.110.11</b>		
12		20	50	<b>711.120.11</b>	<b>811.120.11</b>	<b>911.120.11</b>		
12		25,4	63,5				<b>911.620.11</b>	<b>811.620.11</b>
12,3	31/64	25,4	57,2		<b>811.123.11</b>			
12,3	31/64	25,4	63,5					<b>811.623.11</b>
12,7	1/2	19	57,2		<b>811.127.11</b>			
12,7	1/2	25,4	66,7					<b>811.627.11</b>
12,7	1/2	31,7	82,5					<b>811.628.11</b>
13		20	57	<b>711.130.11</b>		<b>911.130.11</b>		
14		20	50	<b>711.140.11</b>	<b>811.140.11</b>	<b>911.140.11</b>		
14,2	9/16	14,2	57,2		<b>811.142.11</b>			
15		20	57,2	<b>711.150.11</b>	<b>811.150.11</b>	<b>911.150.11</b>		
15,8	5/8	19	66,7		<b>811.158.11</b>			
15,8	5/8	25,4	63,5					<b>811.660.11</b>
16		20	57,2	<b>711.160.11</b>	<b>811.160.11</b>	<b>911.160.11</b>		
16		25,4	63,5					<b>811.661.11</b>
17		20	50	<b>711.170.11</b>				
18		20	50	<b>711.180.11</b>	<b>811.180.11</b>	<b>911.180.11</b>		
18,2	23/32	25,4	57,2		<b>811.182.11</b>			
18,2	23/32	25,4	63,5					<b>811.682.11</b>
19	3/4	20	57,2	<b>711.190.11</b>	<b>811.191.11</b>	<b>911.190.11</b>		
19	3/4	25,4	63,5					<b>811.690.11</b>
20		20	50	<b>711.200.11</b>	<b>811.200.11</b>	<b>911.200.11</b>		
22		20	57,2	<b>711.220.11</b>	<b>811.220.11</b>	<b>911.220.11</b>		
24		20	50	<b>711.240.11</b>		<b>911.240.11</b>		
25		20	50	<b>711.250.11</b>		<b>911.250.11</b>		
25,4	1	19	50,8		<b>811.254.11</b>			
25,4	1	31,7	76,2					<b>811.754.11</b>
28,5	1-1/8	31,7	76,2					<b>811.785.11</b>

**10 pcs. in masterpack**
**811.065.11-X10**
**• HWM**

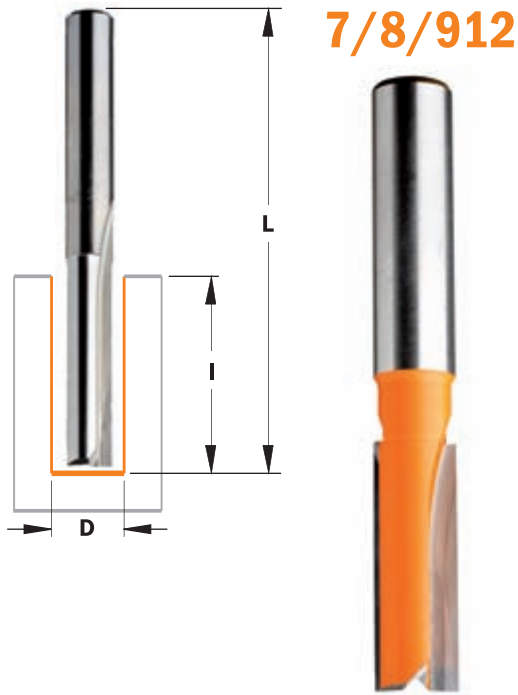

**7/8/912**



**Safety Precautions:** never use damaged or worn bits. Always work at the proper feed rate without forcing the bit. Pay particular attention when making the initial cut with a small diameter bit. For best results when working with small diameter bits, make the cut in more than one pass.

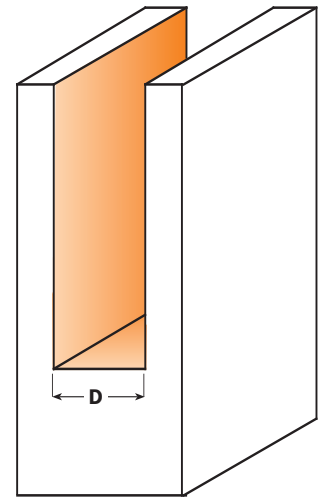

Drawing are 1:1 scale

The top sharpening of the cutting edge allows short plunging operations.

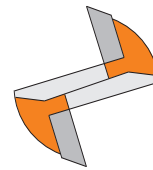

• HWM

D Cutting diameter		I Cutting length	L Overall length	ORDER NO. Shank Ø 6mm	ORDER NO. Shank Ø 6,35mm	ORDER NO. Shank Ø 8mm	ORDER NO. Shank Ø 12mm	ORDER NO. Shank Ø 12,7mm
mm	inches	mm	mm					
• 3		11	60	<b>712.030.11</b>				
• 3,2	1/8	12,7	50,8		<b>812.032.11</b>			
• 4		12	60	<b>712.040.11</b>				
• 6	15/64	25,4	60	<b>712.060.11</b>	<b>812.060.11</b>	<b>912.060.11</b>		
• 6,35	1/4	25,4	60		<b>812.064.11</b>			
• 8	5/16	31,7	60	<b>712.080.11</b>	<b>812.080.11</b>	<b>912.080.11</b>		
• 8		31,7	75				<b>912.580.11</b>	
9		31,7	75				<b>912.590.11</b>	
9,5	3/8	31,7	63,5		<b>812.095.11</b>			
9,5	3/8	31,7	73					<b>812.595.11</b>
10		31,7	60	<b>712.100.11</b>	<b>812.100.11</b>	<b>912.100.11</b>		
10		31,7	70					<b>812.600.11</b>
10		31,7	74				<b>912.600.11</b>	
11,1	7/16	31,7	82,5					<b>812.611.11</b>
12		31,7	60	<b>712.120.11</b>	<b>812.120.11</b>	<b>912.120.11</b>		
12		31,7	70					<b>812.620.11</b>
12		38,1	95				<b>912.621.11</b>	<b>812.621.11</b>
12		50,8	108				<b>912.622.11</b>	
12,7	1/2	31,7	70		<b>812.127.11</b>	<b>912.127.11</b>		
12,7	1/2	38,1	95					<b>812.627.11</b>
12,7	1/2	50,8	108					<b>812.628.11</b>
12,7	1/2	63,5	111					<b>812.629.11</b>
14		31,7	60	<b>712.140.11</b>	<b>812.140.11</b>	<b>912.140.11</b>		
14		31,7	70				<b>912.640.11</b>	
15		31,7	66	<b>712.150.11</b>	<b>812.150.11</b>	<b>912.150.11</b>		
15		31,7	70				<b>912.650.11</b>	
15,8	5/8	31,7	70		<b>812.158.11</b>			
16		31,7	66	<b>712.160.11</b>	<b>812.160.11</b>	<b>912.160.11</b>		
16		31,7	70				<b>912.660.11</b>	<b>812.660.11</b>
18		38,1	80				<b>912.681.11</b>	
19	3/4	38,1	82,5				<b>912.690.11</b>	<b>812.690.11</b>
19	3/4	50,8	92				<b>912.691.11</b>	<b>812.691.11</b>
20		38,1	80				<b>912.701.11</b>	
22		38,1	80				<b>912.721.11</b>	

10 pcs. in masterpack

**812.627.11-X10**

**812.628.11-X10**

**812.629.11-X10**

**812.690.11-X10**



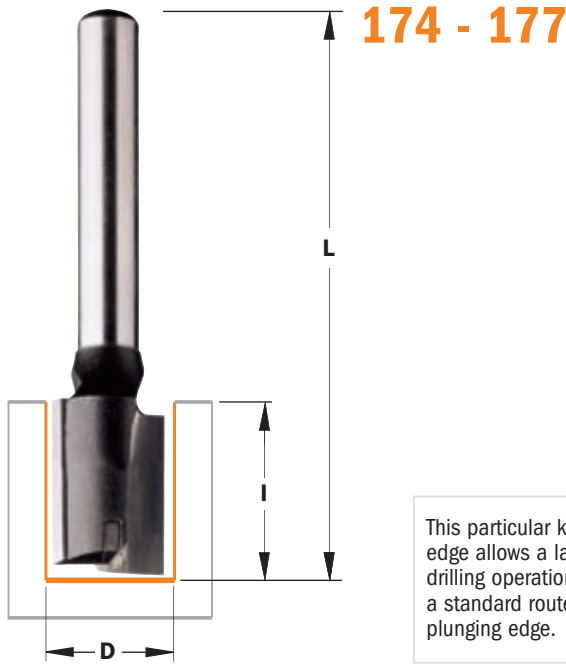

These industrial straight bits are made a kind of stainless steel specifically created to support hard work on route machines and CNC routers. Its cutting plunging edge will allow you to execute any kind of drilling and trimming jobs on soft and hard wood, wood composites and also plastic and laminated materials.

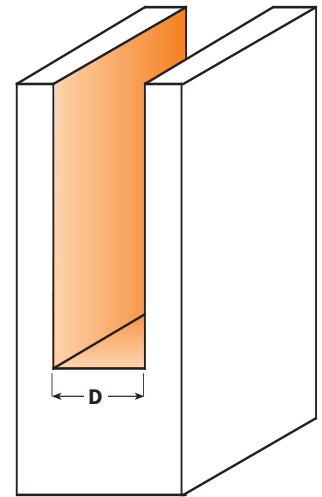

Drawing are 1:1 scale

This particular kind of cutting plunging edge allows a large duration on drilling operation comparing with a standard router bit cutting plunging edge.

**APPLICATION:** used for drilling, grooving or jointing solid wood and wood composites. Can be used on machining centres, CNC routers and hand-held routers equipped with chucks or adaptors.

D Cutting diameter mm	I Cutting length mm	L Overall length mm	ORDER NO. Shank Ø 8mm	ORDER NO. Shank Ø 12mm
• 3	10	55	<b>174.030.11</b>	
• 4	10	55	<b>174.040.11</b>	
• 5	12	55	<b>174.050.11</b>	
• 6	14	55	<b>174.060.11</b>	
• 7	20	55	<b>174.070.11</b>	
• 8	20	55	<b>174.080.11</b>	
• 9	20	55	<b>174.090.11</b>	
10	20	60	<b>174.100.11</b>	
10	35	90		<b>177.100.11</b>
10	40	90	<b>174.101.11</b>	
11	20	60	<b>174.110.11</b>	
12	20	60	<b>174.120.11</b>	
12	35	90		<b>177.120.11</b>
12	40	90	<b>174.121.11</b>	
12	50	100		<b>177.121.11</b>
13	20	60	<b>174.130.11</b>	
14	20	60	<b>174.140.11</b>	
14	35	90		<b>177.140.11</b>
14	40	90	<b>174.141.11</b>	
15	20	60	<b>174.150.11</b>	
16	20	70	<b>174.160.11</b>	
16	35	90		<b>177.160.11</b>
16	40	90	<b>174.161.11</b>	
16	60	110		<b>177.161.11</b>
18	20	70	<b>174.180.11</b>	
18	35	90		<b>177.180.11</b>
20	20	70	<b>174.200.11</b>	
20	35	90		<b>177.200.11</b>
22	20	70	<b>174.220.11</b>	
22	35	90		<b>177.220.11</b>
24	20	70	<b>174.240.11</b>	
24	35	90		<b>177.240.11</b>
26	20	70	<b>174.260.11</b>	
28	20	70	<b>174.280.11</b>	
30	20	70	<b>174.300.11</b>	
30	35	90		<b>177.300.11</b>
35	35	90		<b>177.350.11</b>

• HWM



712.030  
712.040  
812.032



191.635



711.031



Make your house more energy efficient by insulating old doors and windows. A CMT Weatherseal bit is the perfect bit to re-groove door and window frames to accommodate wind blocking inserts. Made of solid carbide for strength and endurance.

Special economical double-sided design lets you save money by offering two tips in one bit; with the same features as the one-sided weatherseal bit. Only available with a 3mm cutting diameter.

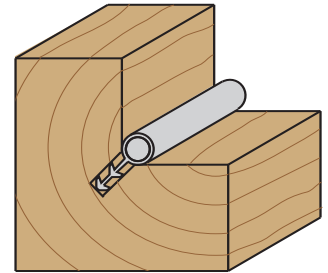
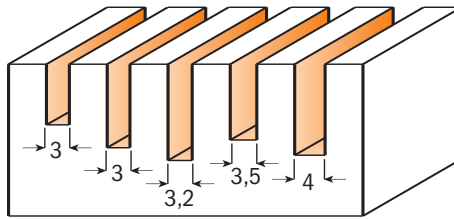

Drawing are 1:1 scale

D Cutting diameter		I Cutting length mm	L Overall length mm	ORDER NO.	ORDER NO.			
mm	inches			Shank Ø 6mm	Shank Ø 6,35mm			
3		8	70	<b>711.031.11</b>				
3		11	60	<b>712.030.11</b>				
3,2	1/8	12,7	50,8		<b>812.032.11</b>			
3,5		10	60	<b>191.635.11</b>				
4		12	60	<b>712.040.11</b>				

Weatherseal bits



**7/813.001**



Make your house more energy efficient by insulating old doors and windows. A CMT Weatherseal bit is the perfect bit to re-groove door and window frames to accommodate wind blocking inserts. Made of solid carbide for strength and endurance.

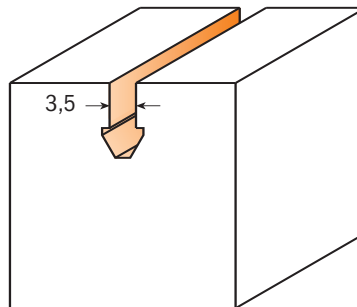

Drawing are 1:1 scale

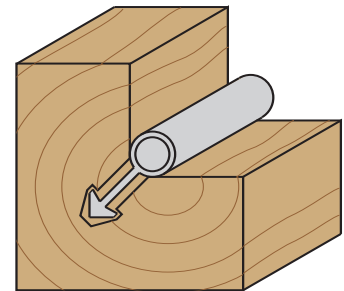

D Cutting diameter		I Cutting length mm	L Overall length mm	ORDER NO.	ORDER NO.			
mm				Shank Ø 6mm	Shank Ø 6,35mm			
3,5		8	70	<b>713.001.11</b>	<b>813.001.11</b>			



**7/8/911B**  
**7/8/912B**



Whether you are a full time professional or a part time woodworking enthusiast, discover the unlimited possibilities of template routing with a CMT pattern bit. Pair up these double fluted bits with your choice of template to produce cabinet and furniture pieces, signs, toys and any other creative project. Carbide tipped to last longer, CMT pattern bits are equipped with the bearing above the cutter letting you work with the template on top of the wood. This gives you a clear view of what you are routing so you can work confidently and accurately.

**Safety tips:** Make sure your router is in top condition. The template must be securely fastened to the work piece.

When choosing a bit, carefully consider the thickness of the template and all the implications of the cut. Opt for the shortest bit possible for the project you are working on.

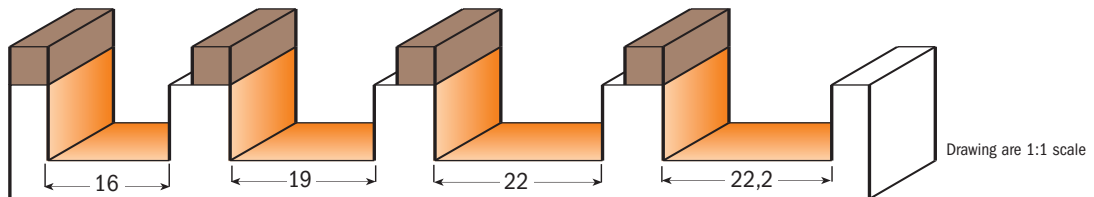
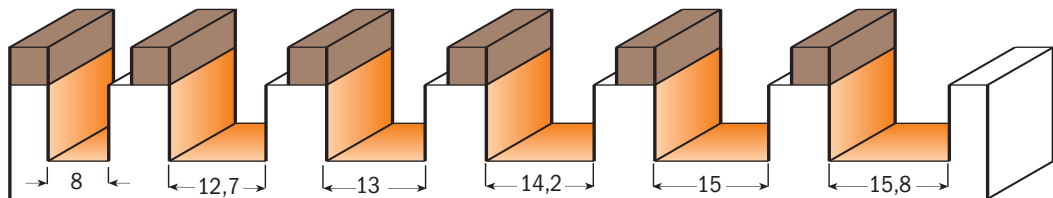
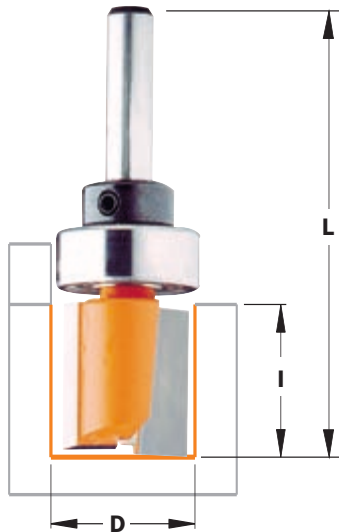

Drawing are 1:1 scale

D Cutting diameter		I Cutting length	Spare bearing	ORDER NO. Shank Ø 6mm	ORDER NO. Shank Ø 6,35mm	ORDER NO. Shank Ø 8mm	ORDER NO. Shank Ø 12mm	ORDER NO. Shank Ø 12,7mm
mm	inches	mm						
8	5/16	25,4	791.010.00		<b>811.081.11B</b>			
12,7	1/2	19	791.010.00		<b>811.127.11B</b>			
13		20	791.023.00	<b>711.130.11B</b>				
14,2	9/16	14,2	791.009.00		<b>811.142.11B</b>			
15		20	791.024.00	<b>711.150.11B</b>				
15,8	5/8	12,7	791.009.00		<b>811.159.11B</b>			
15,8	5/8	19	791.009.00		<b>811.158.11B</b>			
16		20	791.025.00			<b>911.160.11B</b>		
19	3/4	20	791.007.00	<b>711.190.11B</b>				
19	3/4	20	791.004.00		<b>811.191.11B</b>			
19	3/4	25,4	791.011.00				<b>811.690.11B</b>	
22		20	791.005.00			<b>911.220.11B</b>		
22,2	7/8	25,4	791.021.00					<b>811.222.11B*</b>
<b>long series</b>								
12,7	1/2	31,7	791.010.00		<b>812.127.11B</b>			
15		31,7	791.024.00	<b>712.150.11B</b>				
15,8	5/8	31,7	791.009.00		<b>812.158.11B</b>			
16		31,7	791.025.00			<b>912.160.11B</b>		
19	3/4	38,1	791.011.00				<b>912.690.11B</b>	<b>812.690.11B</b>
19	3/4	50,8	791.011.00				<b>912.691.11B</b>	<b>812.691.11B</b>

**Spare parts:** **541.003.00** Stop collar for Ø6mm shanks  
**541.004.00** Stop collar for Ø8mm shanks  
**541.005.00** Stop collar for Ø12mm shanks  
**799.001.00** Ø9,5/12,7mm bushings

**541.001.00** Stop collar for Ø6,35mm shanks  
**541.002.00** Stop collar for Ø12,7mm shanks  
**541.006.00** Stop collar for Ø9,5mm shanks  
**991.056.00** 1,5mm hex key

\* Shank Ø9,5mm with bushings Ø12,7mm



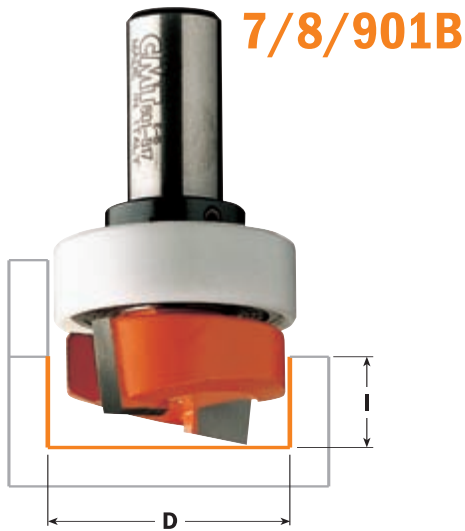

Equipped with thick carbide tips and negative shear angle design, CMT Mortising bits guarantee you a flawless performance. Mortise perfect hinges with no splintered edges or rough bottoms.

They also make an easy job of piece work in both natural wood and wood composites.

Fit most popular mortising jigs. The CMT mortising bit with top bearing guide is the perfect bit for sign making or any kind of template work.

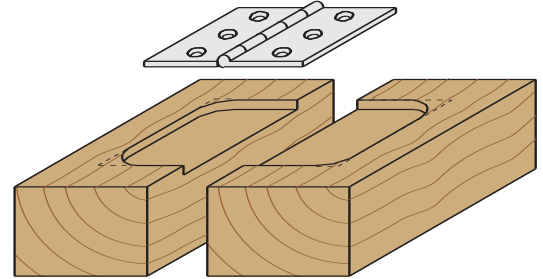

This is an example of how to use a CMT mortising bit to fit a hinge.

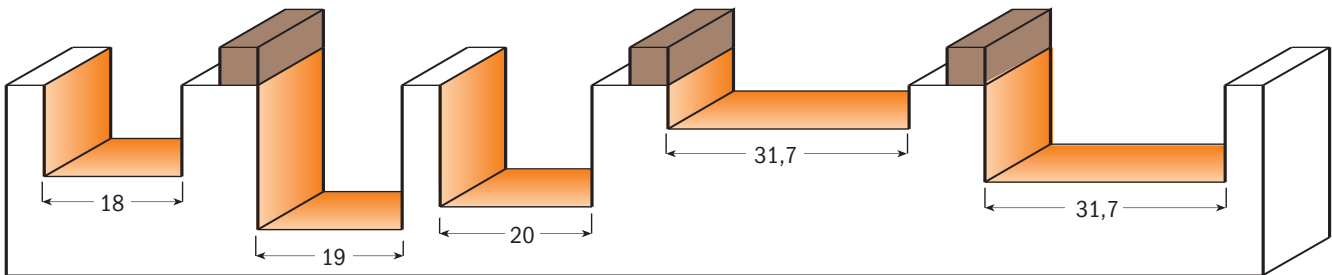
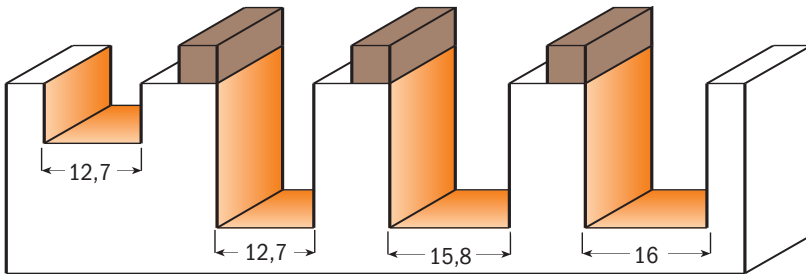

Drawing are 1:1 scale

D Cutting diameter		I Cutting length	Spare bearing	ORDER NO.	ORDER NO.	ORDER NO.	ORDER NO.	ORDER NO.
mm	inches	mm		Shank Ø 6mm	Shank Ø 6,35mm	Shank Ø 8mm	Shank Ø 12mm	Shank Ø 12,7mm
12,7	1/2	7,9			<b>801.128.11</b>			
12,7	1/2	19		<b>701.127.11</b>	<b>801.127.11</b>	<b>901.127.11</b>	<b>901.627.11</b>	<b>801.627.11</b>
15,8	5/8	19			<b>801.158.11</b>			
16		19		<b>701.160.11</b>		<b>901.160.11</b>		
18		12		<b>701.180.11</b>		<b>901.180.11</b>		
19	3/4	19		<b>701.190.11</b>	<b>801.190.11</b>	<b>901.190.11</b>		<b>801.690.11</b>
20		16		<b>701.200.11</b>		<b>901.200.11</b>		
31,7	1-1/4	5,7						<b>801.818.11</b>
31,7	1-1/4	12,7			<b>801.317.11</b>		<b>901.817.11</b>	<b>801.817.11</b>
<b>with top bearing</b>								
12,7	1/2	7,9	791.010.00		<b>801.128.11B</b>			
12,7	1/2	19	791.010.00		<b>801.127.11B</b>			
15,8	5/8	19	791.009.00		<b>801.158.11B</b>			
16		19	791.025.00			<b>901.160.11B</b>		
19	3/4	19	791.007.00	<b>701.190.11B</b>				
19	3/4	19	791.004.00		<b>801.190.11B</b>			
31,7	1-1/4	5,7	791.015.00					<b>801.818.11B</b>
31,7	1-1/4	12,7	791.015.00					<b>801.817.11B</b>

**Spare parts:** **541.003.00** Stop collar for Ø6mm shanks  
**541.004.00** Stop collar for Ø8mm shanks  
**991.056.00** 1,5mm hex key

**541.001.00** Stop collar for Ø6,35mm shanks  
**541.002.00** Stop collar for Ø12,7mm shanks

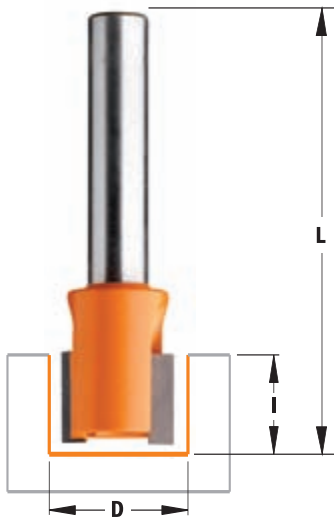

7/902



CMT hinge recesser bits are ideal for shallow lateral routing cuts such as recessing hinges.

**Shop Tips:** Corners will require final trimming square with a hand chisel or a corner chisel.

The special construction allows good chip clearance and plunging.

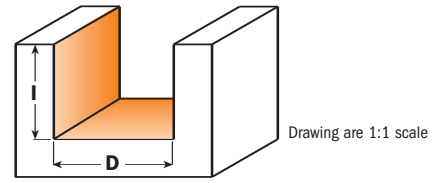

Drawing are 1:1 scale

Ideal for recessing hinges cuts

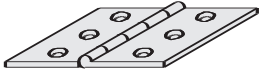

D Cutting diameter mm	I Cutting length mm	L Overall length mm	ORDER NO. Shank Ø 6mm	ORDER NO. Shank Ø 8mm
12	12,7	57	702.120.11	902.120.11
13	12,7	57	702.130.11	902.130.11
14	12,7	57	702.140.11	902.140.11
15	12,7	57	702.150.11	902.150.11
16	12,7	57	702.160.11	902.160.11
20	12,7	57	702.200.11	902.200.11
22	12,7	57	702.220.11	902.220.11
24	12,7	57	702.240.11	902.240.11
25	12,7	57	702.250.11	902.250.11

Dado & Planer bits



852B



Constructed with thick carbide tips and downward shear angle design, CMT Mortising Bits give you flawless performance. The negative shear angle of the cutting edges pushes the wood fibers down as they cut, allowing you to rout perfect hinge mortises with no splintered edges or rough bottoms. They also make an easy job of piece work in both natural wood and wood composites. We offer bits to fit most popular mortising jigs.



852

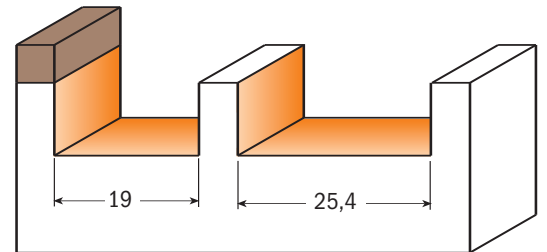

Drawing are 1:1 scale

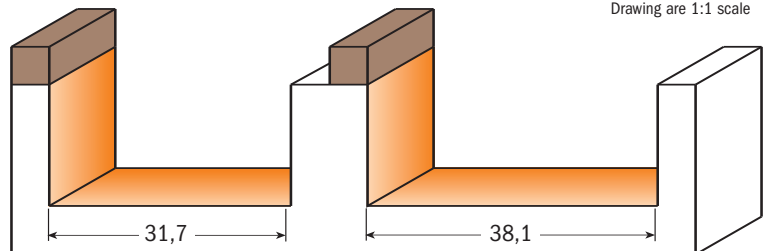

D Cutting diameter mm	inches	I Cutting length mm	Spare bearing	ORDER NO. Shank Ø 6,35mm	Spare bearing	ORDER NO. Shank Ø 12,7mm
19	3/4	9,5		852.001.11		852.501.11
25,4	1	9,5				852.502.11
31,7	1-1/4	15,8				852.503.11
38,1	1-1/2	15,8				852.504.11
<b>with top bearing</b>						
19	3/4	9,5	791.004.00	852.001.11B	791.011.00	852.501.11B
31,7	1-1/4	15,8	791.015.00			852.503.11B
38,1	1-1/2	15,8	791.020.00			852.504.11B

Spare parts: 541.001.00 Stop collar for Ø6,35mm shanks

541.002.00 Stop collar for Ø12,7mm shanks

991.056.00 1,5mm hex key

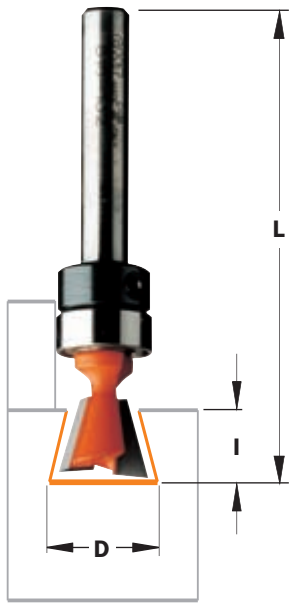

**7/818B**



**7/8/918**



The beautifully crafted dovetail joint is a classic that appeals to both professionals and novices alike. Admired for its attractiveness in box and exposed joint projects, the dovetail is remarkably strong and functional. CMT dovetail bits are available in 25 different sizes so you can stretch your creativity to the limit. See the illustrations on the next page for dovetail joinery possibilities.

CMT dovetail bits are designed to fit all popular jigs including Leigh, Keller, JoinTECH and Omnijig systems. You are sure to find the bit you are looking for in our vast selection of cutting sizes and angles. Check the overall length of the bit before placing an order to be sure you get the size you need - CMT makes bits specifically to fit on jigs and routers that require a longer shank length.

**Shop Tips:** Two passes are recommended when routing dovetails with a template. Check that the dovetails have been cut through completely and smoothly before removing the workpiece. For even easier routing and less stress on your dovetail bit, run the first pass with a straight bit.

Use a dovetail on your router table equipped with a fence to achieve difficult chamfer angles.

**Safety Tips:** If a dovetail bit jams while working, adjust the position of the bit in the collet and make sure the cutting depth is correct. Do not lift the router out of the template.

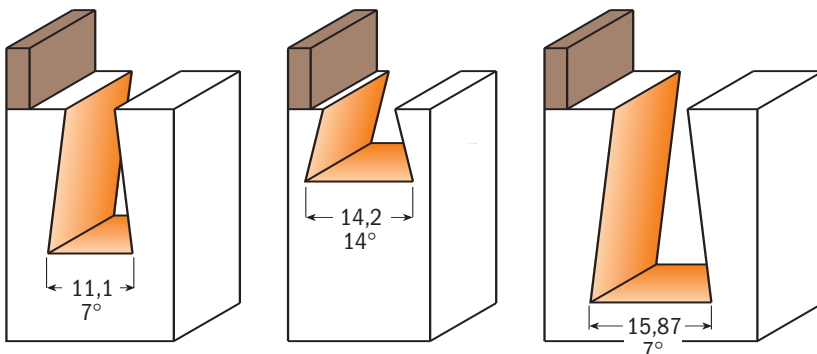
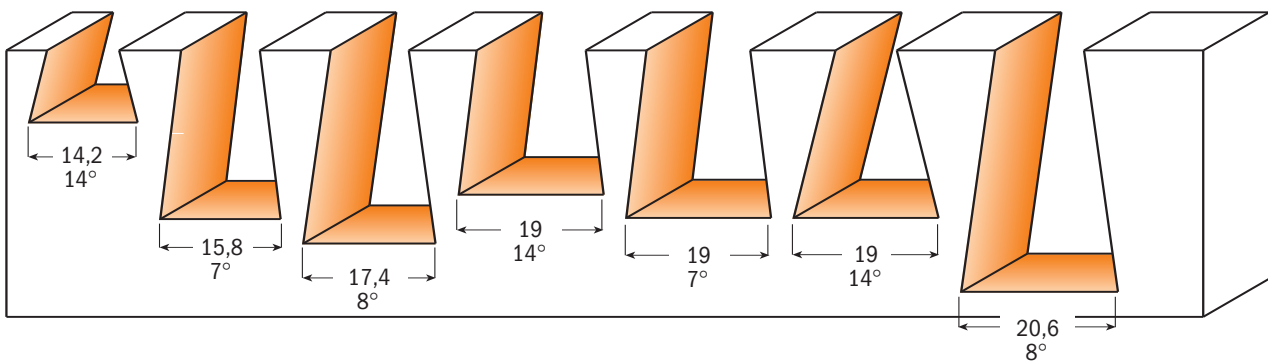
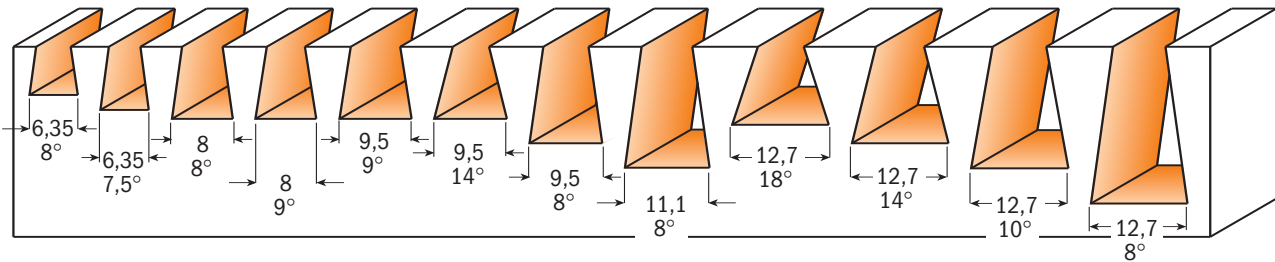

Drawing are 1:1 scale

Manufacturer/Model	ORDER NO.
CMT-Enlock1	718.098.11B - 818.098.11B
	718.127.11B - 818.128.11B
CMT300	718.127.11 - 818.128.11
	918.127.11 - 818.628.11
Hoffmann W1	718.053.11 - 818.053.11
W2	718.079.11 - 818.079.11
W3	718.093.11 - 818.093.11



**7/8/918 - 7/818B**

Here are a few of the beautiful dovetail joints you can produce using CMT bits

Through dovetail

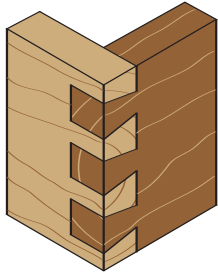

Half-blind dovetail

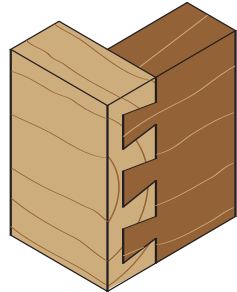

Variably-spaced dovetail

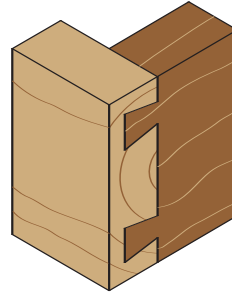

Sliding dovetail

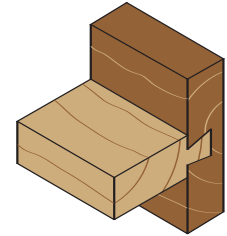

D Cutting diameter mm inches	I Cutting length mm	L Overall length mm	A Cutting angle	ORDER NO. Shank Ø 6mm	ORDER NO. Shank Ø 6,35mm	ORDER NO. Shank Ø 8mm	ORDER NO. Shank Ø 12mm	ORDER NO. Shank Ø 12,7mm
•5,3	4	43	17°	<b>718.053.11</b>	<b>818.053.11</b>			
•6	8,3	60	7,5°	<b>718.060.11</b>				
•6,35 1/4	6,35	50,8	8°		<b>818.065.11</b>			
•6,35 1/4	8,3	63,5	7,5°		<b>818.064.11</b>			<b>818.564.11</b>
•7,9	6	43	18°	<b>718.079.11</b>	<b>818.079.11</b>			
•8 5/16	9,5	54	8°		<b>818.081.11</b>			
•8 5/16	9,5	52,5	9°		<b>818.080.11</b>			
•8 5/16	9,5	63,5	9°					<b>818.580.11</b>
•9,3	7,3	43	19°	<b>718.093.11</b>	<b>818.093.11</b>			
•9,5 3/8	9,5	52,5	9°	<b>718.095.11</b>	<b>818.096.11</b>	<b>918.095.11</b>		
•9,5 3/8	9,5	63,5	9°					<b>818.596.11</b>
•9,5 3/8	9,5	60,3	14°		<b>818.098.11</b>			
•9,5 3/8	12,7	60,3	8°		<b>818.097.11</b>			
11,1 7/16	15,9	60,3	8°		<b>818.111.11</b>			
12,7 1/2	10,3	60,3	18°		<b>818.132.11</b>			
12,7 1/2	12,7	52,4	14°	<b>718.127.11</b>	<b>818.128.11</b>	<b>918.127.11</b>		
12,7 1/2	12,7	63,5	14°					<b>818.628.11</b>
12,7 1/2	12,7	62	14°		<b>818.130.11</b>			
12,7 1/2	16	60,3	10°		<b>818.133.11</b>			
12,7 1/2	20,6	69,8	8°		<b>818.129.11</b>	<b>918.129.11</b>		
13,5 17/32	19,05	61,5	7°					<b>818.635.11</b>
14,2 9/16	9,5	50,8	14°		<b>818.142.11</b>			
16 5/8	22	60,3	7°	<b>718.158.11</b>	<b>818.158.11</b>	<b>918.158.11</b>		
16 5/8	22	66,7	7°				<b>918.658.11</b>	<b>818.658.11</b>
17,4 11/16	25,4	77,6	8°					<b>818.674.11</b>
19 3/4	19	77,6	14°					<b>818.691.11</b>
19 3/4	22	60,3	7°	<b>718.190.11</b>	<b>818.190.11</b>	<b>918.190.11</b>		
19 3/4	22	66,7	7°				<b>918.690.11</b>	<b>818.690.11</b>
19 3/4	22	60,3	14°		<b>818.191.11</b>			
20,6 13/16	31,7	84,1	8°					<b>818.706.11</b>
<b>with top bearing</b>								
8,73 11/32	10,3	58	7°		<b>818.087.11B</b>			
•9,5 3/8	9,5	60,3	14°	<b>718.098.11B</b>	<b>818.098.11B</b>			
11,1 7/16	19	66,7	7°		<b>818.113.11B</b>			
12,7 1/2	12,7	52,4	14°	<b>718.127.11B</b>	<b>818.128.11B</b>			
14,2 9/16	9,5	50,8	14°		<b>818.142.11B</b>			
<b>with top bearing (shank Ø9,5mm)</b>								
16 5/8	25,4	68,3	7°		<b>818.159.11B</b>			

**Spare parts:** **791.009.00** Ø6,35/15,8mm bearing  
**541.001.00** Stop collar for Ø6,35mm shanks  
**791.010.03** Ø12,7mm bearing and stop collar kit

**791.010.00** Ø6,35/12,7mm bearing  
**541.006.00** Stop collar for Ø9,5mm shanks

**791.021.00** Ø9,5/22mm bearing  
**991.056.00** 1,5mm hex key

• HWM

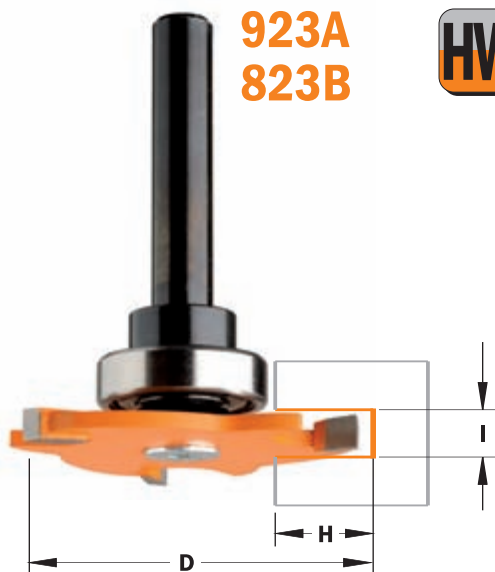

**923A**  
**823B**



The possible uses of this bit are almost : you can rout grooves and rabbets, T or dovetail joints on wood panels.

Each bit has three carbide tipped cutters and has an orange coloured PTFE coating, it features anti-kickback design too.

The 22mm bearing is included for a cutting depth of 12,8mm.

The bit and the slot cutter are available also separately.

I Cutting length mm inches	D Cutting diameter mm	H Cutting depth mm	ORDER NO. Shank Ø 8mm	ORDER NO. Shank Ø 12,7mm
3	47,6	12,8	<b>923.330.11A</b>	
3,2 1/8	47,6	12,8		<b>823.332.11B</b>
4 5/32	47,6	12,8	<b>923.340.11A</b>	<b>823.340.11B</b>
5	47,6	12,8	<b>923.350.11A</b>	
6,4 1/4	47,6	12,8		<b>823.364.11B</b>

## Slot cutter arbors



with stop collar



**8/924**



These three wing carbide tipped slot cutters feature anti-kickback three wing blade design and CMT's trademark orange PTFE Industrial Coating. All cutters feature an 8mm bore that fits CMT's arbors (items 7/8/924).

I Cutting length mm inches	D Cutting diameter mm	F Bore diameter mm	ORDER NO.
3	47,6	8	<b>823.330.11</b>
3,2 1/8	47,6	8	<b>823.332.11</b>
4 5/32	47,6	8	<b>823.340.11</b>
5	47,6	8	<b>823.350.11</b>
6,4 1/4	47,6	8	<b>823.364.11</b>

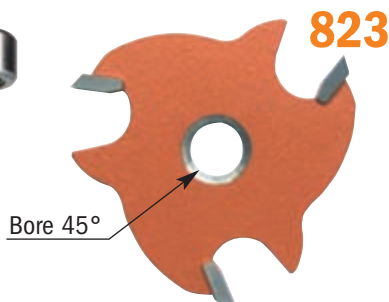

**823**

Bore 45°

### Assembly illustration

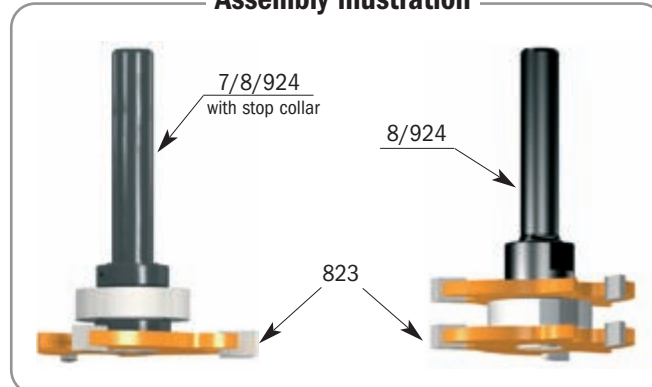

DESCRIPTION	ORDER NO. Shank Ø 6mm	ORDER NO. Shank Ø 6,35mm	ORDER NO. Shank Ø 8mm	ORDER NO. Shank Ø 12,7mm
Slot cutter arbor without bearing (with stop collar)	<b>724.061.00</b>	<b>824.061.00</b>	<b>924.081.00</b>	<b>824.121.00</b>
Slot cutter arbor with bearing (with stop collar)	<b>724.061.10</b>	<b>824.061.10</b>	<b>924.081.10</b>	<b>824.121.10</b>
Slot cutter arbor without bearing			<b>924.082.00</b>	<b>824.122.00</b>
Slot cutter arbor with bearing			<b>924.082.10</b>	<b>824.122.10</b>

**Spare parts:** **791.012.00** Ø8-22mm bearing  
**791.013.00** Ø12,7-22mm bearing  
**541.515.00** 0,1mm spacer  
**541.518.00** 1mm spacer

**541.001.00** Stop collar for Ø6,35mm shanks  
**541.003.00** Stop collar for Ø6mm shanks  
**541.516.00** 0,3mm spacer  
**990.055.00** Vite TSPEI M5x12mm

**541.002.00** Stop collar for Ø12,7mm shanks  
**541.004.00** Stop collar for Ø8mm shanks  
**541.517.00** 0,5mm spacer

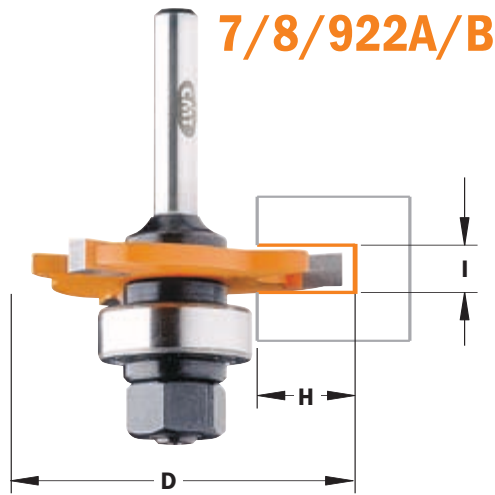

**7/8/922A/B**



Uses for the CMT three wing slot cutter are almost infinite. Cut slots and grooves for splines, biscuits, T-molding or tongue and groove joints.

Every cutter features anti-kickback design, micrograin carbide tips and orange CMT trademark non-stick PTFE coating.

CMT slot cutters are available as a blade only or with your choice of a 6, 8, 12, 6,35 or 12,7mm diameter arbor which includes a 22mm diameter bearing for a cutting depth of up to 12,7mm .

**Note:** For biscuit joints, use l=4mm slot cutter.

I Cutting length	mm inches	D Cutting diameter	mm	H Cutting depth	mm	ORDER NO.	ORDER NO.	ORDER NO.	ORDER NO.	ORDER NO.
						Shank Ø 6mm	Shank Ø 6,35mm	Shank Ø 8mm	Shank Ø 12mm	Shank Ø 12,7mm
1,5		47,6		12,8		<b>722.315.11A</b>		<b>922.315.11A</b>	<b>922.315.11B</b>	
1,6	1/16	47,6		12,8			<b>822.316.11A</b>			<b>822.316.11B</b>
2	5/64	47,6		12,8		<b>722.320.11A</b>	<b>822.320.11A</b>	<b>922.320.11A</b>	<b>922.320.11B</b>	<b>822.320.11B</b>
2,4	3/32	47,6		12,8			<b>822.324.11A</b>			<b>822.324.11B</b>
2,5		47,6		12,8		<b>722.325.11A</b>		<b>922.325.11A</b>	<b>922.325.11B</b>	
3		47,6		12,8		<b>722.330.11A</b>		<b>922.330.11A</b>	<b>922.330.11B</b>	
3,2	1/8	47,6		12,8			<b>822.332.11A</b>			<b>822.332.11B</b>
3,5		47,6		12,8		<b>722.335.11A</b>		<b>922.335.11A</b>	<b>922.335.11B</b>	
4	5/32	47,6		12,8		<b>722.340.11A</b>	<b>822.340.11A</b>	<b>922.340.11A</b>	<b>922.340.11B</b>	<b>822.340.11B</b>
4,8	3/16	47,6		12,8			<b>822.348.11A</b>			<b>822.348.11B</b>
5		47,6		12,8		<b>722.350.11A</b>		<b>922.350.11A</b>	<b>922.350.11B</b>	
6	15/64	47,6		12,8		<b>722.360.11A</b>	<b>822.360.11A</b>	<b>922.360.11A</b>	<b>922.360.11B</b>	<b>822.360.11B</b>
6,4	1/4	47,6		12,8			<b>822.364.11A</b>			<b>822.364.11B</b>

These three wing carbide tipped Slot Cutters feature anti-kickback three wing blade design and CMT's trademark orange P.T.F.E. Industrial Coating. All cutters feature an 8mm bore that fits CMT's arbors (items 7/8/924).

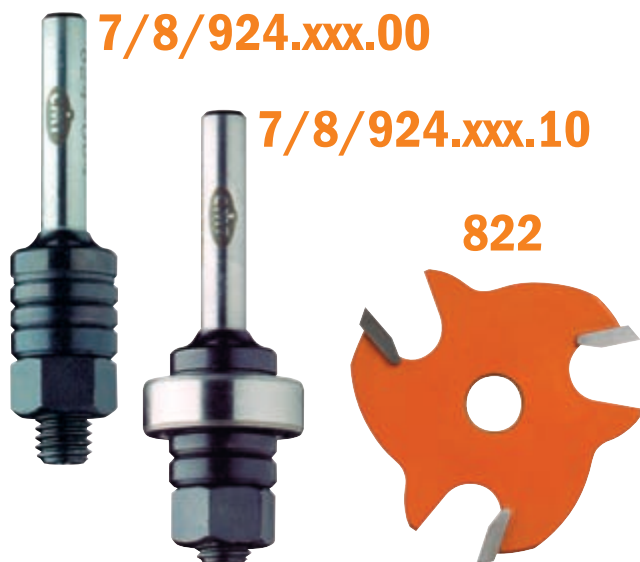

I Cutting length	mm inches	D Cutting diameter	mm	F Bore diameter	mm	ORDER NO.
1,5		47,6		8		<b>822.315.11</b>
1,6	1/16	47,6		8		<b>822.316.11</b>
1,8		47,6		8		<b>822.318.11</b>
2	5/64	47,6		8		<b>822.320.11</b>
2,2		47,6		8		<b>822.322.11</b>
2,4	3/32	47,6		8		<b>822.324.11</b>
2,5		47,6		8		<b>822.325.11</b>
2,8		47,6		8		<b>822.328.11</b>
3		47,6		8		<b>822.330.11</b>
3,2	1/8	47,6		8		<b>822.332.11</b>
3,5		47,6		8		<b>822.335.11</b>
4	5/32	47,6		8		<b>822.340.11</b>
4,8	3/16	47,6		8		<b>822.348.11</b>
5		47,6		8		<b>822.350.11</b>
6	15/64	47,6		8		<b>822.360.11</b>
6,4	1/4	47,6		8		<b>822.364.11</b>

DESCRIPTION	ORDER NO. Shank Ø 6mm	ORDER NO. Shank Ø 6,35mm	ORDER NO. Shank Ø 8mm	ORDER NO. Shank Ø 12mm	ORDER NO. Shank Ø 12,7mm
Slot cutter arbor without bearing	<b>724.060.00</b>	<b>824.064.00</b>	<b>924.080.00</b>	<b>924.120.00</b>	<b>824.127.00</b>
Slot cutter arbor with bearing	<b>724.060.10</b>	<b>824.064.10</b>	<b>924.080.10</b>	<b>924.120.10</b>	<b>824.127.10</b>
Slot cutter arbor without bearing, long series			<b>924.083.00</b>		
Slot cutter arbor with bearing, long series			<b>924.083.10</b>		

**Spare parts:** **791.005.00** Spare bearing Ø22mm  
**541.518.00** 1mm spacer

**541.501.00** 4mm spacer  
**990.020.00** Dado M8

**541.500.00** 3mm spacer



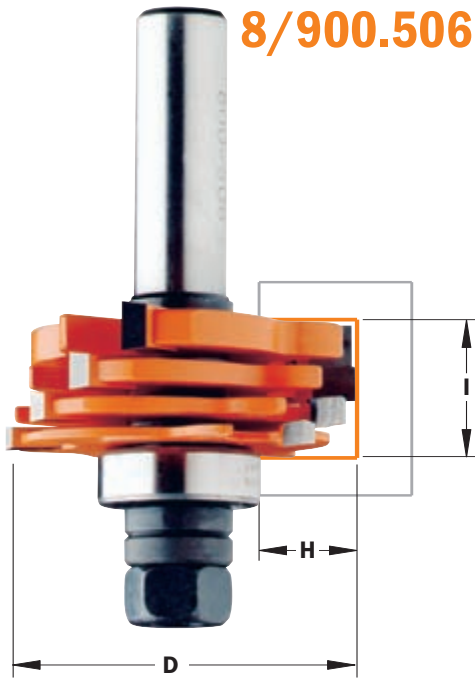

**8/900.506**



Create slots, grooves and rabbets in materials from 3,2mm to 18mm in depth by using the adjustable CMT Three Wing slot cutter set. See chart below for details on spacing and correct cutter combinations. Ideal for biscuit joints and milling perfect tongue and groove joints. This set includes:

- 4 carbide tipped cutters 3,2mm, 4mm, 4,8mm, 6,4mm
- 1 arbor 12mm or 12,7mm
- 1 ball bearing (22mm) for 12,7mm cut
- 17 shims: (8x0,1mm - 4x0,5mm - 3x1mm and 2x4mm)

**Safety tips:** Never use the slot cutter set without shims between the cutters. The distance between the cutters can vary from 1mm to 1,7mm. A shim must also be positioned between the ball bearing and the cutters.

**Shop tips:** The bearings kit **791.711.00** allows to make 6,35 and 9,5mm cutting depth.

**Note:** The carbide edges of the cutters should never touch; arrange the shims as illustrated below. Use only the thicknesses provided in the set. Be sure all cutters are assembled in the proper right rotational direction below. Looking down the arbor the cutters will turn clockwise.

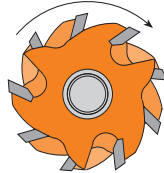

Cutter combination	Cutting height	
	mm	mm
A	3,2	
B	4	
C	4,8	
D	6,4	
A + B	6,4	a 7,1
A + C	7,2	a 7,9
A + D	8,8	a 9,5
B + C	8	a 8,7
B + D	9,6	a 10,3
C + D	10,4	a 11,1
A + B + C	10,4	a 11,8
A + B + D	11,9	a 13,3
A + C + D	12,7	a 14,1
B + C + D	13,5	a 14,9
A + B + C + D	15,9	a 18

Use shims to adjust cut width: MIN.1mm - MAX 1,7mm

I	D	H	Spare bearing	ORDER NO.	ORDER NO.
Cutting length	Cutting diameter	Cutting depth		Shank	Shank
mm	mm	mm		Ø 12mm	Ø 12,7mm
3,2-18	47,6	12,8	791.005.00	<b>900.506.11</b>	<b>800.506.11</b>

- Spare parts:**
- 824.128.00** Ø12,7mm arbor with shims
  - 924.128.00** Ø12mm arbor with shims
  - 791.711.00** Kit of two bearing 28,5mm and 34,9mm for slot cutter
  - 541.517.00** 0,5mm spacer
  - 791.005.00** Spare bearing Ø22mm
  - 541.515.00** 0,1mm spacer
  - 541.518.00** 1mm spacer
  - 990.020.00** Dado M8

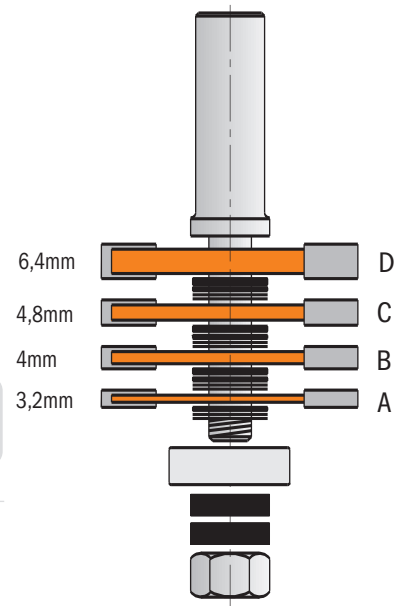

## Tongue and groove set



Make tongue and groove joints without the complicated process of taking apart and reassembling bits. The new CMT tongue and groove set gives you one bit to groove the slot and a separate bit to mill the tongue. Or use your imagination and put them to work individually on other projects. Makes tongue and groove cuts in wood up to 19mm thick.

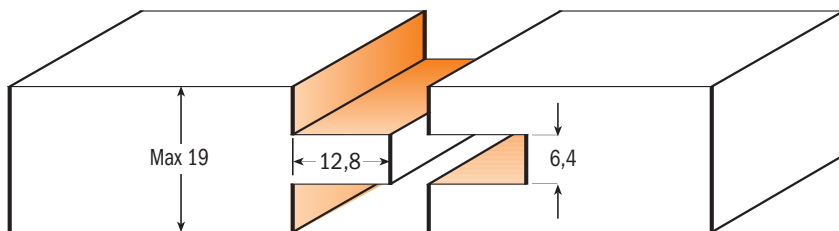

Drawing are 1:1 scale

I	D	H	Spare bearing	ORDER NO.	ORDER NO.
Cutting length	Cutting diameter	Cutting depth		Shank	Shank
mm	mm	mm		Ø 12mm	Ø 12,7mm
19	47,6	12,8	791.005.00	<b>900.626.11</b>	<b>800.626.11</b>

- Spare parts:**
- 824.131.00** Ø12,7mm arbor with shims
  - 791.005.00** Spare bearing Ø22mm
  - 541.517.00** 0,5mm spacer
  - 924.131.00** Ø12mm arbor with shims
  - 541.515.00** 0,1mm spacer
  - 541.518.00** 1mm spacer
  - 822.364.11** Slot cutter 6,4mm spacer
  - 541.516.00** 0,3mm spacer
  - 990.020.00** Dado M8



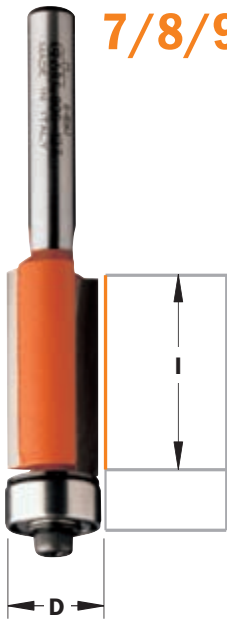

**7/8/906**



To trim even the most difficult projects, we have designed a series of truly indispensable bits. Our CMT flush trim bits are available in a wide range of sizes that are sure to satisfy any woodworking need. Use these carbide faced bits for precision work on laminates or for quick template work with an excellent finish.

**Shop Tips:** These bits are excellent for making through mortise. Use a straight bit (#711.130.11) to groove the area to make the through mortise. With a drill bit (#517.130.31) bore a hole through the wood at one end of the groove. Turn the workpiece over to finish the mortise. Use a flush trim bit with a cutting length slightly longer than the fillet, following the groove made on the opposite side of the workpiece with the ball bearing guide.

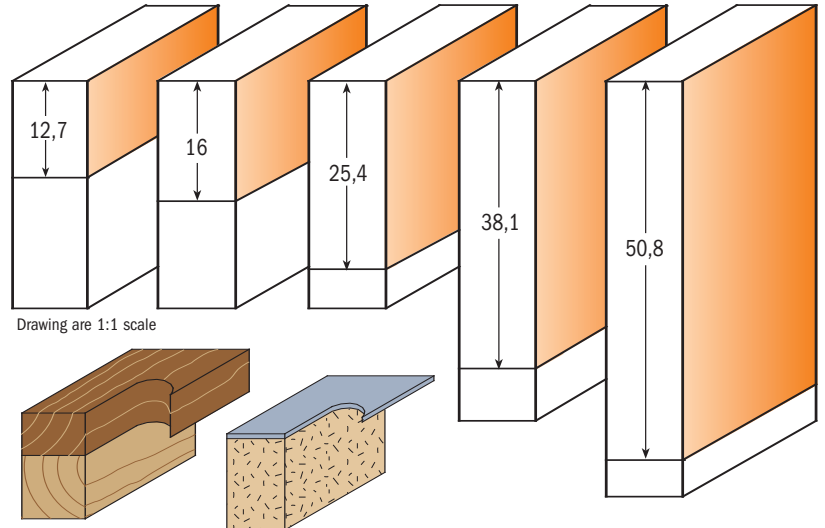

Drawing are 1:1 scale

• **HWM**

I Cutting length		D Cutting diameter	Spare bearing	ORDER NO.	ORDER NO.	ORDER NO.	ORDER NO.	ORDER NO.
mm	inches	mm		Shank Ø 6mm	Shank Ø 6,35mm	Shank Ø 8mm	Shank Ø 12mm	Shank Ø 12,7mm
•25,4	1	6,35	791.035.00		<b>806.064.11</b>			
12,7	1/2	9,5	791.002.00	<b>706.096.11</b>	<b>806.096.11</b>	<b>906.096.11</b>		
12,7	1/2	12,7	791.003.00	<b>706.128.11</b>	<b>806.128.11</b>	<b>906.128.11</b>	<b>906.628.11</b>	<b>806.628.11</b>
16		19	791.007.00	<b>706.190.11</b>		<b>906.190.11</b>		
25,4	1	9,5	791.002.00	<b>706.095.11</b>	<b>806.095.11</b>	<b>906.095.11</b>		
25,4	1	12,7	791.003.00	<b>706.127.11</b>	<b>806.127.11</b>	<b>906.127.11</b>	<b>906.627.11</b>	<b>806.627.11</b>
38,1	1-1/2	12,7	791.003.00				<b>906.629.11</b>	<b>806.629.11</b>
50,8	2	12,7	791.003.00				<b>906.630.11</b>	<b>806.630.11</b>
<b>10 pcs. in masterpack</b>					<b>806.095.11-X10</b>			
					<b>806.096.11-X10</b>			
					<b>806.127.11-X10</b>			<b>806.627.11-X10</b>
					<b>806.128.11-X10</b>			<b>806.628.11-X10</b>
								<b>806.629.11-X10</b>

Spare parts: **990.422.00** Ø9,5mm shield

**990.423.00** Ø12,7mm shield

**990.058.00** 1/8W screw

**991.057.00** 3/32" hex key



**Flush trim bit set**



Indispensable in any shop. The new 3-piece Trim bit set gives you the option to trim laminates or do template work in one convenient set. Individual bits are listed below.

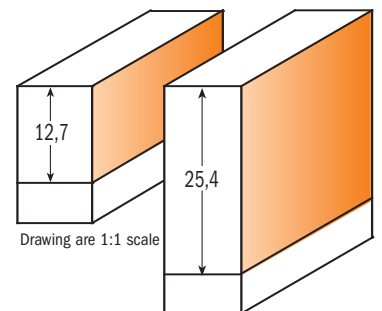

Drawing are 1:1 scale

DESCRIPTION	ORDER NO.
Flush trim bit set (D=9,5-19mm)	Shank Ø 6,35mm <b>806.001.11</b>



7/8/906



These new super duty bits represent the finest of the extensive line of CMT flush trim bits with ball bearing guides. A negative shear angle cutting edge and 3/4" cutting diameter set CMT flush trim bits apart from standard bits. Work quickly and safely to get a superior finish with absolute minimal chipping.

**Safety Tip:** Dust and chips from laminate materials are hazardous to your health and safety. Always wear a dust mask and eye protection when doing router work.

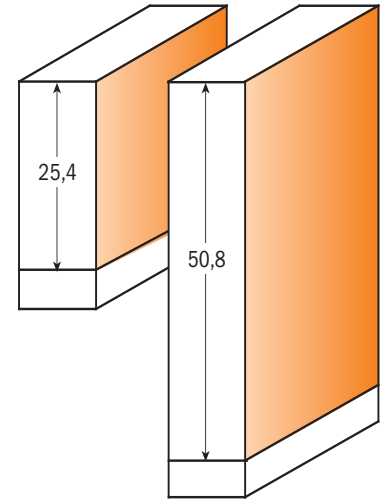
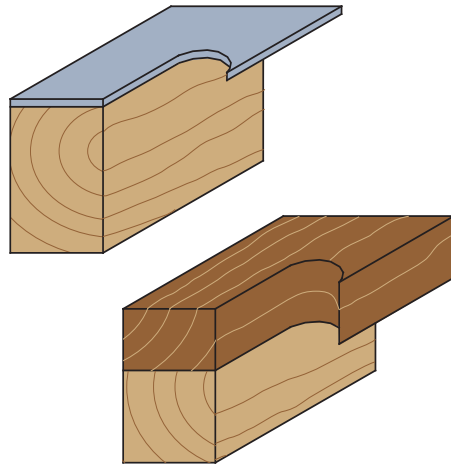

Drawings are 1:1 scale

I Cutting length		D Cutting diameter	Spare bearing	ORDER NO.	ORDER NO.	ORDER NO.	ORDER NO.	ORDER NO.
mm	inches	mm		Shank Ø 6mm	Shank Ø 6,35mm	Shank Ø 8mm	Shank Ø 12mm	Shank Ø 12,7mm
25,4	1	19	791.004.00	<b>706.191.11</b>	<b>806.191.11</b>	<b>906.191.11</b>	<b>906.691.11</b>	<b>806.691.11</b>
38,1	1-1/2	19	791.004.00				<b>906.692.11</b>	<b>806.692.11</b>
50,8	2	19	791.004.00				<b>906.690.11</b>	<b>806.690.11</b>

Spare parts: **990.058.00** 1/8W screw

**991.057.00** 3/32" hex key

**541.550.00** Shield for screw 3,25mm

DP Flush trim bits for laminates

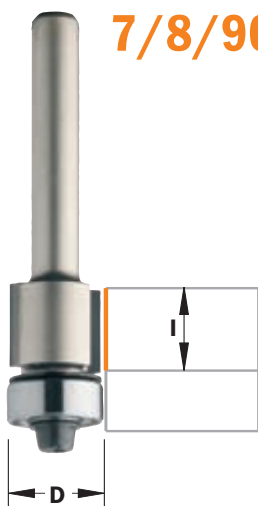

7/8/906



These new super duty DP (polycrystalline diamond) bits represent the ultimate in the extensive line of CMT flush trim bits.

Investing in CMT DP flush trim will save the cabinet manufacturer time and money as they last at least 20x's longer than conventional carbide tipped flush trim bits.

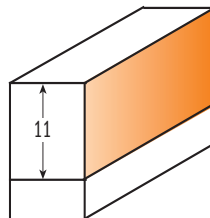

Drawings are 1:1 scale

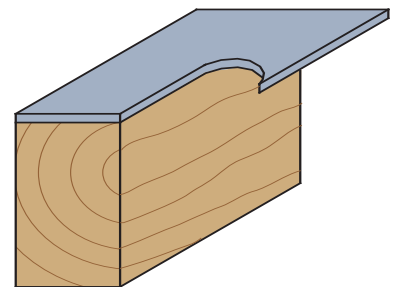

I Cutting length		D Cutting diameter	Spare bearing	ORDER NO.	ORDER NO.	ORDER NO.		
mm	inches	mm		Shank Ø 6mm	Shank Ø 6,35mm	Shank Ø 8mm		
11	7/16	12,7	791.003.00	<b>706.128.61</b>	<b>806.128.61</b>	<b>906.128.61</b>		

Spare parts: **990.423.00** Ø12,7mm shield  
**791.003.00** Spare bearing Ø12,7mm

**990.058.00** 1/8W screw  
**991.057.00** 3/32" hex key

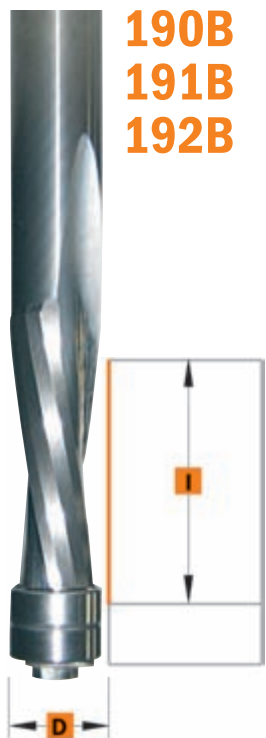

**190B**  
**191B**  
**192B**



The new line of CMT solid carbide spiral flush trim bits are manufactured with a special super-micrograin formulation that has increased hardness with a higher transverse rupture point.

Combined with the low helix cutting angle, the new CMT solid carbide spiral flush trim bits with bearings allow the cabinet maker to shear wood and wood products cleanly while providing more efficient chip ejection than standard flush trim bits. In a production setting, these new bits will run cooler and the edge will stay sharper longer which translates into increased productivity for your shop.

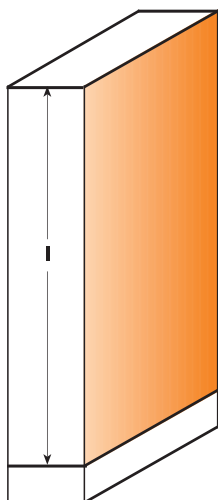

Drawings are 1:1 scale

S=D Cutting diameter mm inches	I Cutting length mm	L Overall length mm	ORDER NO. Shank Ø 12mm	ORDER NO. Shank Ø 12,7mm
<b>Z2+2 Upcut &amp; Downcut spiral bit</b>				
12,7 1/2	42	114	<b>190.127.11B</b>	<b>190.508.11B</b>
<b>Z2 Upcut spiral bit</b>				
12,7 1/2	31,7	89		<b>191.505.11B</b>
12,7 1/2	50,8	114	<b>191.127.11B</b>	<b>191.507.11B</b>
<b>Z2 Downcut spiral bit</b>				
12,7 1/2	31,7	89		<b>192.505.11B</b>
12,7 1/2	50,8	114	<b>192.127.11B</b>	<b>192.507.11B</b>

Spare parts: **791.010.00** Spare bearing Ø12,7mm

**541.301.00** 6mm seeger UNI 7435-6

**3in1 Flush trim bit for laminates**

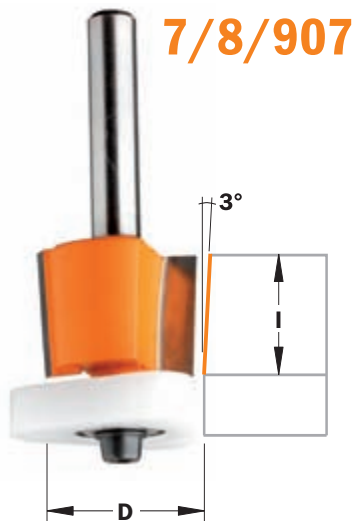

**7/8/907**



**3in1** New flush trim bits with Delrin® Triangular bearings is your best partner for laminate trimming. Infact it solves 3 of the most common problems that occur in flush trimming in cabinet shops:

- 1) The freezing of the bearings from glue; infact the Delrin® with his anti-stick properties greatly reduces the likelihood of bearing failure.
- 2) The extended guide surface of the new Delrin® bearing will perfectly match the work surface without scratching like the steel bearing and garantees the maximum stability.
- 3) The shear angle cutting edge reduces the need for filing.

**3in1** bit is ideal on plastic laminates as well as aluminium laminate!

Patent pending

- Extended guide surface
- Non freezing
- Non scratch surface

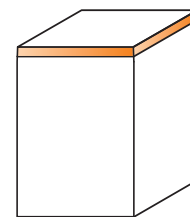
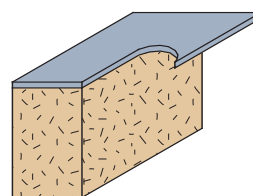

Drawings are 1:1 scale

**Perfect trimming with the conical edges!**

Thanks to the innovating conical edges of this bit you will always get perfect cuts even after resharpening. In fact the most popular problem you have with the standard flush trim bits is the undersize diameter after resharpening which leaves the mark on the material; now with the new CMT construction you could resharpen up to six times without any problem. Just remember to adjust your bit up or down as for the illustration.

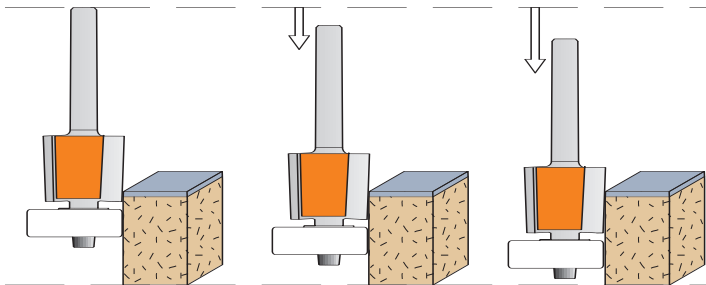

I Cutting length mm inches	D Cutting diameter mm	Spare bearing	ORDER NO. Shank Ø 6mm	ORDER NO. Shank Ø 6,35mm	ORDER NO. Shank Ø 8mm	ORDER NO. Shank Ø 12,7mm
12,7 1/2	12,7	791.042.00	<b>707.128.11</b>	<b>807.128.11</b>	<b>907.128.11</b>	
15,87 5/8	19	791.043.00	<b>707.190.11</b>	<b>807.190.11</b>	<b>907.190.11</b>	<b>807.690.11</b>

Spare parts: **791.042.00** Ø12,7mm triangular bearing

**791.043.00** Ø19mm triangular bearing

**990.058.00** 1/8W screw

**991.057.00** 3/32" hex key



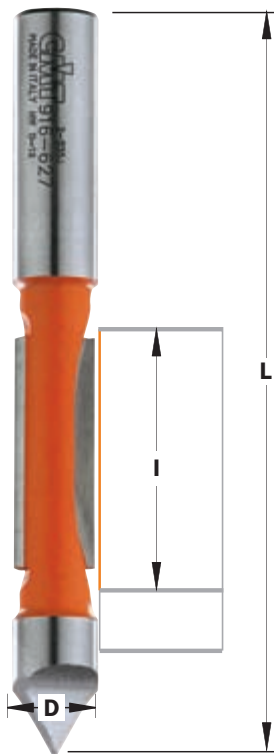

7/8/916



716.061

How much time do you end up spending making openings in paneling, drywall, siding, doors or windows? With the CMT panel pilot bit, the job just got quicker. The point plunges smoothly and easily and the carbide edges cut clean and fast. All of this adds up to accurate cuts in less time and with less effort - great for trimming formica, veneer and other laminates.

**Safety Tips:** Always use extra caution when working near electrical outlets and boxes - always disconnect the current. Make sure the bit does not go so deep as to cut the wires.

A unique and time saving bit, the CMT Double Panel Pilot Bit is perfect for making openings and slots in veneers and laminates. The lower portion of the cutting edge is located under the bearing and allows you to cut on both sides of the material. Durable carbide tipped cutters are spaced 12mm apart and each cutter can work in stock up to 18mm thick.

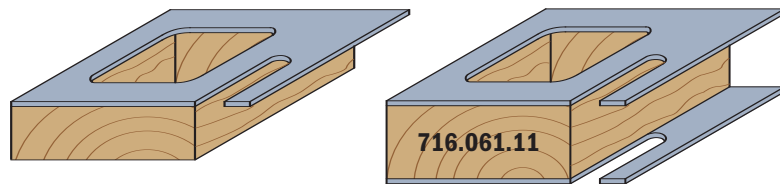

• HWM

D Cutting diameter mm inches	I Cutting length mm	L Overall length mm	Z No. of teeth	ORDER NO. Shank Ø 6mm	ORDER NO. Shank Ø 6,35mm	ORDER NO. Shank Ø 8mm	ORDER NO. Shank Ø 12mm	ORDER NO. Shank Ø 12,7mm
6	19	64	1	716.060.11				
•6	19	60	1	716.060.21				
•6	18+18	70	1+1	716.061.11				
6,35 1/4	19	64	1		816.064.11			
8	19	64	1			916.080.11		
9,53 3/8	25,4	78	2		816.095.11			
12,7 1/2	31,7	102	2				916.627.11	816.627.11
<b>10 pcs. in masterpack</b>								<b>816.627.11-X10</b>

Flush and V-Groove bits

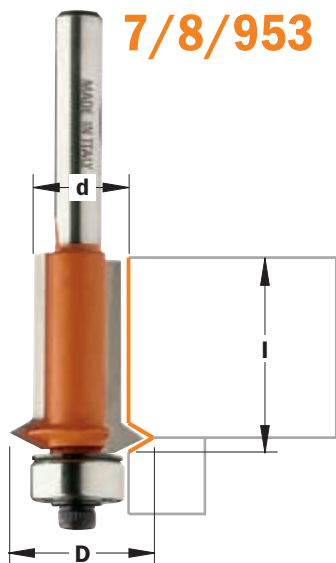

7/8/953



An absolutely indispensable bit for making cabinets. CMT Flush and V-Groove bits allow you to make cabinet front frames in 25mm stock that fit perfectly with the sides. The added V-cutter feature makes a decorative groove along the hinge joint to hide the seam.

**Shop Tip:** For best results, leave less than 3mm overhang on cabinet front frames for easier routing.

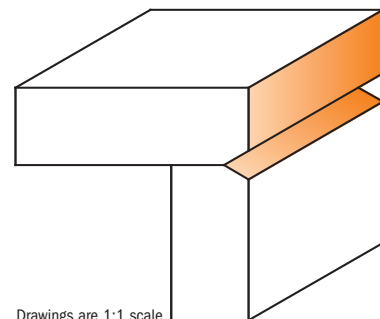

Drawings are 1:1 scale

d Cutting diameter mm inches	D Overall cutting diameter mm	I Cutting length mm	ORDER NO. Shank Ø 6mm	ORDER NO. Shank Ø 6,35mm	ORDER NO. Shank Ø 8mm	ORDER NO. Shank Ø 12mm	ORDER NO. Shank Ø 12,7mm
12,7 1/2	19	25,4	753.001.11	853.001.11	953.001.11	953.501.11	853.501.11
<b>Spare parts:</b>			990.423.00 Ø12,7mm shield	791.003.00 Spare bearing Ø12,7mm	990.058.00 1/8W screw	991.057.00 3/32" hex key	



Work to your highest standards with the CMT combination trimmer bit. Now you can cut, trim and bevel all laminates without having to change bits. Get great results in straight or angle cuts in both hard and soft woods. CMT Combination bits are available in three popular sizes, each with carbide-faced cutting edges to efficiently execute bevel or straight edges. NOTE: must be used with edge guide, separate bearing guide or fence.

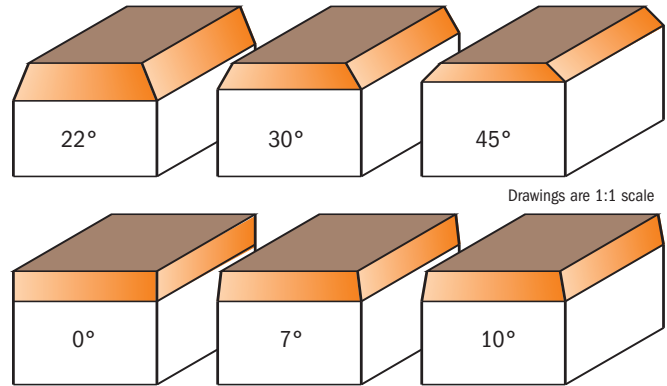

• HWM

A Cutting angle	D Cutting diameter mm	I Cutting length mm	ORDER NO. Shank Ø 6mm	ORDER NO. Shank Ø 6,35mm	ORDER NO. Shank Ø 8mm
0° - 22°	12	12,7	<b>721.022.11</b>	<b>821.022.11</b>	
0° - 30°	12	12,7	<b>721.030.11</b>	<b>821.030.11</b>	<b>921.030.11</b>
0° - 45°	12	12,7	<b>721.045.11</b>	<b>821.045.11</b>	
• 0°	6,35	9,5		<b>842.095.11</b>	
• 7°	6,35	6,35		<b>843.063.11</b>	
• 0° - 10°	6,35	9,5		<b>843.064.11</b>	
<b>10 pcs. in masterpack</b>				<b>842.095.11-X50</b>	
				<b>843.063.11-X50</b>	

**Combination flush and bevel trim bits**

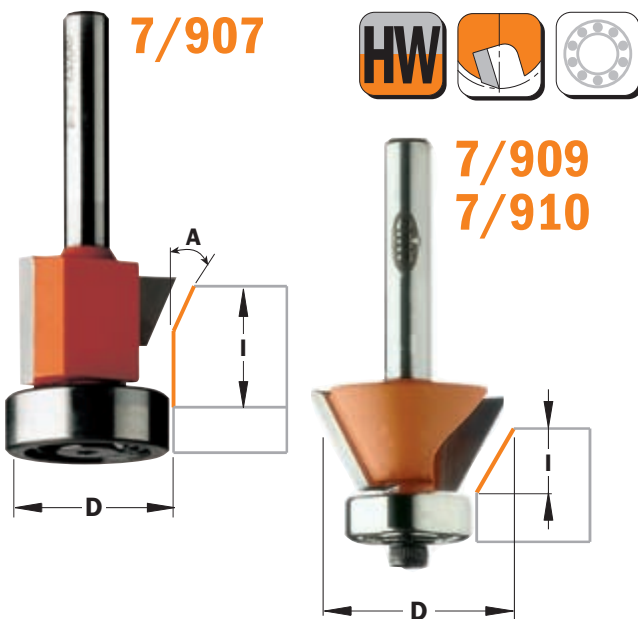

Using CMT Combination Flush and Bevel Trim Bits is the easiest and most precise way to put finishes on laminates. To achieve a variety of angles no changing is necessary; simply position the bit at the lowest cutting depth for perfect right angle cuts, or increase the height to create rounded off edges for angles up to 25°. Includes ball bearing guide for easy template work.

CMT Bevel and Chamfer bits are ideal for putting a superior finish on laminates. These high quality bits have two flutes for smoother cutting and protective bearings so as not to damage the workpiece. The cutting depth of the bit can be varied to obtain precise borders and rounded edges on both soft and hard woods. Perfect for making rounded edges on table legs and other easily damaged areas on furniture pieces.

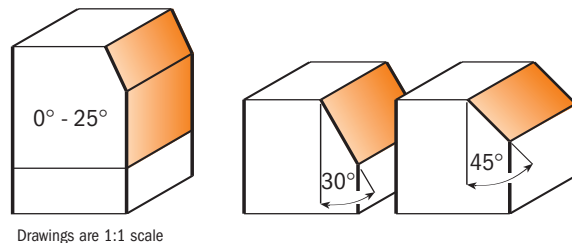

A Cutting angle	D Cutting diameter mm	I Cutting length mm	Spare bearing	ORDER NO. Shank Ø 6mm	ORDER NO. Shank Ø 8mm
0° - 25°	19 - 24,5	15	791.007.00	<b>707.210.11</b>	<b>907.210.11</b>
30°	26	8,5	791.018.00	<b>709.260.11</b>	<b>909.260.11</b>
45°	27	5,5	791.018.00	<b>710.260.11</b>	<b>910.260.11</b>

Spare parts: **990.423.00** Ø12,7mm shield **990.058.00** 1/8W screw **991.062.00** 2,5mm hex key  
**990.004.00** M4 screw **991.057.00** 3/32" hex key

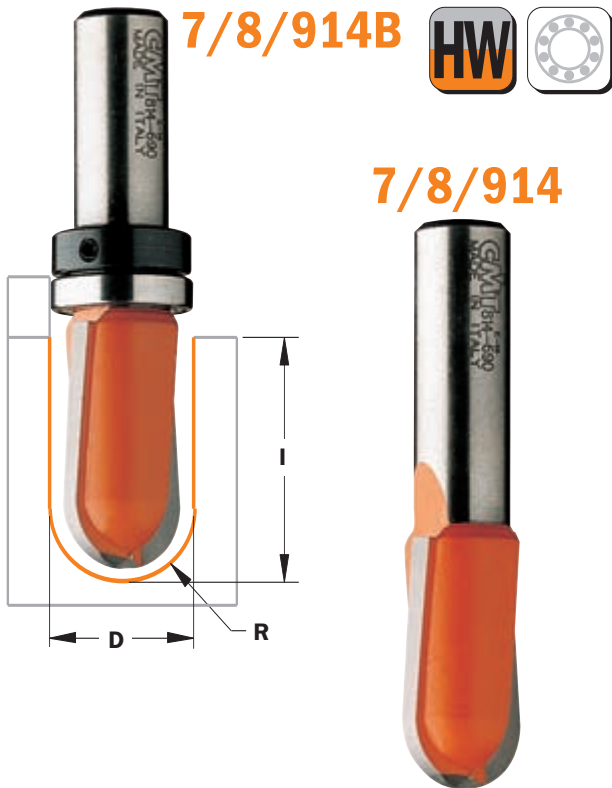

Personalize your doors, drawer fronts, panels or any surface you choose with your own signature motif. CMT round nose bits in solid carbide or with carbide tipped flutes let you create engraving in any wood or wood product. We offer a complete selection of diameters and cutting depths so you can achieve the effects you want. Mounted on your router table, you can work materials up to 31,7mm in depth. For even more elaborate decorations, we also offer top bearing bits - use your own template with one of these bits to produce truly unique doors and drawer fronts. A favourite item for professional sign makers, craft makers and hobbyists.

**Shop Tips:** More than one pass is recommended when making cove edges. To prevent splintering, begin with a shallow initial pass and deepen gradually.

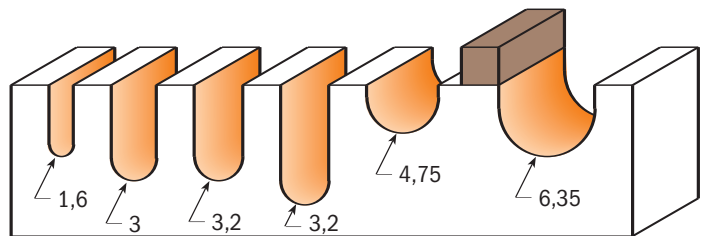

Drawings are 1:1 scale

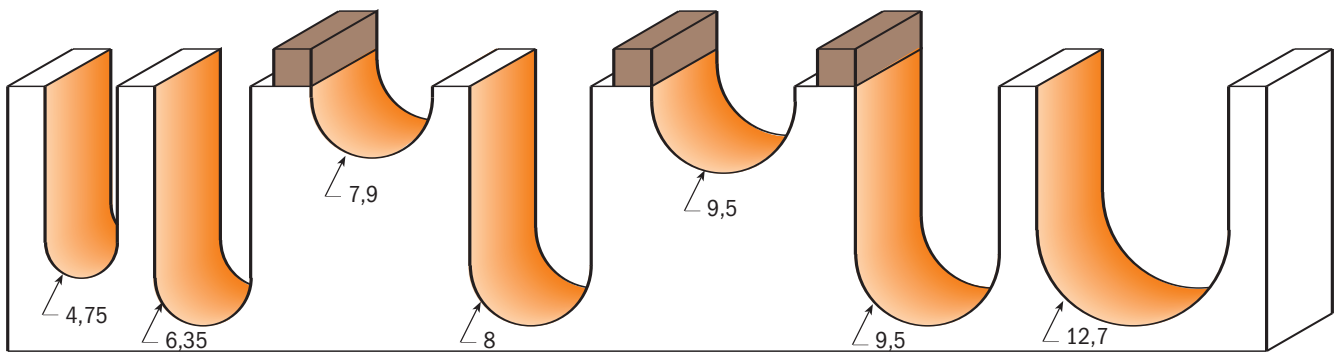

R Radius		D Cutting diameter	I Cutting length	ORDER NO. Shank Ø 6mm	ORDER NO. Shank Ø 6,35mm	ORDER NO. Shank Ø 8mm	ORDER NO. Shank Ø 12mm	ORDER NO. Shank Ø 12,7mm
mm	inches	mm	mm					
• 1,6	1/16	3,2	9,5	<b>714.032.11</b>	<b>814.032.11</b>	<b>914.032.11</b>		
• 3		6	12,7	<b>714.060.11</b>		<b>914.060.11</b>		
• 3,2	1/8	6,4	12,7		<b>814.064.11</b>			
• 3,2	1/8	6,4	15,9					<b>814.564.11</b>
4,75	3/16	9,5	6,4	<b>714.095.11</b>	<b>814.095.11</b>	<b>914.095.11</b>		
4,75	3/16	9,5	25,4					<b>814.595.11</b>
6,35	1/4	12,7	9,5	<b>714.127.11</b>	<b>814.127.11</b>	<b>914.127.11</b>		
6,35	1/4	12,7	31,7				<b>914.627.11</b>	<b>814.627.11</b>
7,9	5/16	15,8	9,5	<b>714.160.11</b>	<b>814.160.11</b>	<b>914.160.11</b>		
7,9	5/16	15,8	31,7					<b>814.660.11</b>
9,5	3/8	19	11,5	<b>714.190.11</b>	<b>814.190.11</b>	<b>914.190.11</b>		
9,5	3/8	19	31,7				<b>914.690.11</b>	<b>814.690.11</b>
12,7	1/2	25,4	31,7				<b>914.754.11</b>	<b>814.754.11</b>
16	5/8	31,7	18,5				<b>914.817.11</b>	<b>814.817.11</b>
<b>with top bearing</b>								
6,35	1/4	12,7	9,5		<b>814.127.11B</b>			
7,9	5/16	15,8	9,5		<b>814.160.11B</b>	<b>914.160.11B</b>		
9,5	3/8	19	11,5	<b>714.190.11B</b>	<b>814.190.11B</b>			
9,5	3/8	19	31,7					<b>814.690.11B</b>

<b>Spare parts:</b>	<b>791.010.00</b> Ø12,7mm bearing	<b>791.004.00</b> Ø19mm bearing with Ø6,35mm bore	<b>541.004.00</b> Stop collar for Ø8mm shanks
	<b>791.009.00</b> Ø15,8mm bearing with Ø6,35mm bore	<b>791.011.00</b> Ø19mm bearing with Ø12,7mm bore	<b>541.002.00</b> Stop collar for Ø12,7mm shanks
	<b>791.025.00</b> Ø16mm bearing with Ø8mm bore	<b>541.003.00</b> Stop collar for Ø6mm shanks	<b>991.056.00</b> 1,5mm hex key
	<b>791.007.00</b> Ø19mm bearing with Ø6mm bore	<b>541.001.00</b> Stop collar for Ø6,35mm shanks	

• HWM



Each of these sets include 3 of the most widely used CMT Round Nose bits. These solid carbide or carbide tipped bits are perfect for sign making, engraving, or adding flutes and veins to doors or drawer fronts. Available in 6,35mm and 12,7mm shanks.

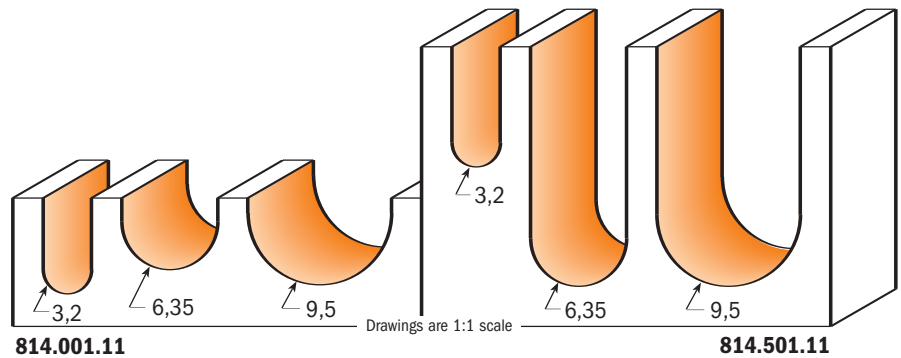

814.001.11

814.501.11

DESCRIPTION	ORDER NO.	ORDER NO.
	Shank Ø 6,35mm	Shank Ø 12,7mm
Round nose set	814.001.11	814.501.11

**Keyhole and T-Slot bits**

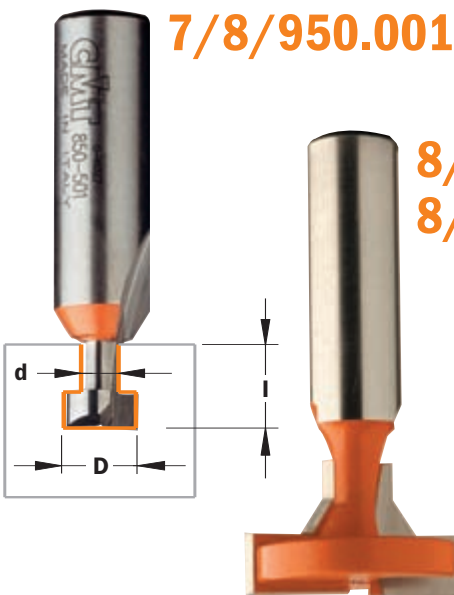

With the CMT keyhole bit you can make holes that keep your frames, plaques or any wall hanging perfectly straight and attached to the wall.

The bit bores an entry hole in the wood, then proceeds to cut a 4,8mm hole and finishes by boring a larger opening under the surface. The perfect way to securely mount wall hangings on screws and nails.

**Safety Tips:** Be sure the workpiece is securely fastened to the router table or work bench.

**Shop Tips:** Recommended for use with a plunge router.

8/950.601-602  
8/950.603

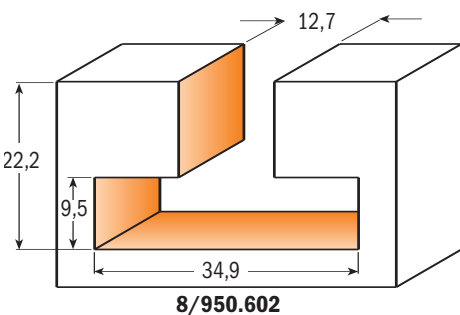
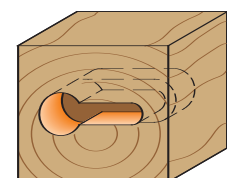
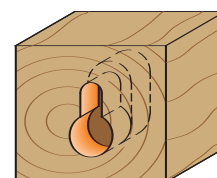
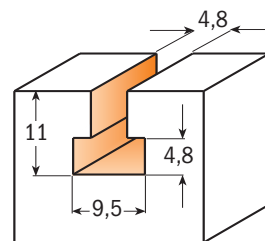

8/950.602

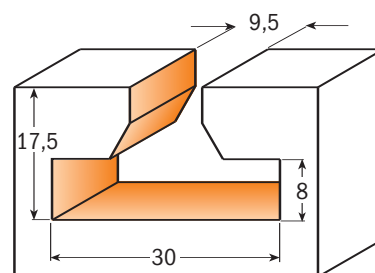

8/950.601

Drawings are 1:1 scale

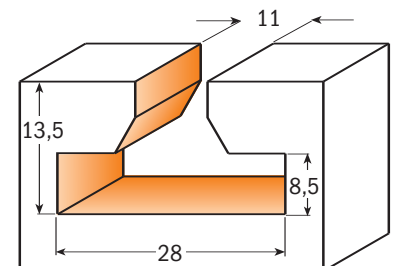

8/950.603

D Cutting diameter	d Small cutting diam.	l Cutting length	ORDER NO. Shank Ø 6mm	ORDER NO. Shank Ø 6,35mm	ORDER NO. Shank Ø 8mm	ORDER NO. Shank Ø 12mm	ORDER NO. Shank Ø 12,7mm
9,5 3/8	4,8	11	750.001.11	850.001.11	950.001.11	950.501.11	850.501.11
28	11	13,5				950.603.11	850.603.11
30	9,5	17,5				950.601.11	850.601.11
34,9 1-3/8	12,7	22,2				950.602.11	850.602.11



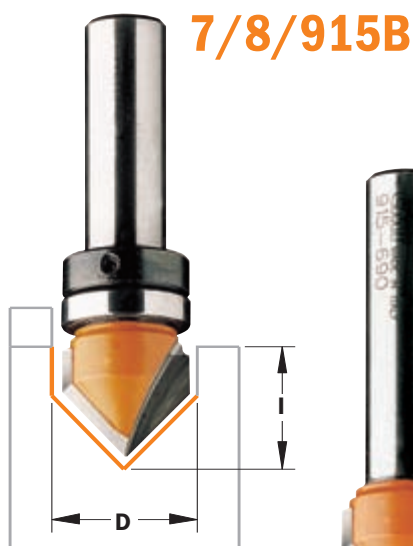

These double cutting edge CMT bits offer you an almost endless range of woodworking possibilities. Make clean, perfect incisions in panels or drawer fronts; chamfer edges or engrave beautiful lettering. In addition, CMT has versatile top bearing bits that let you follow whatever template you choose (see series 715B-815B-915B).

Like all CMT bits, they are made of super strength Fatigue Proof® steel with carbide-tipped cutting edges and are coated with our trademark orange PTFE non-stick coating.

These bits are ideal for routing sings, or almost any project that is suitable for accurate template routing.

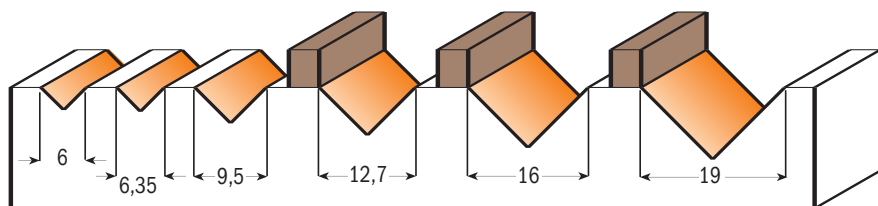

Drawings are 1:1 scale

• HWM

D Cutting diameter		I Cutting length	A Cutting angle	ORDER NO. Shank Ø 6mm	ORDER NO. Shank Ø 6,35mm	ORDER NO. Shank Ø 8mm	ORDER NO. Shank Ø 12mm	ORDER NO. Shank Ø 12,7mm
• 6		8	90°	<b>715.060.11</b>		<b>915.060.11</b>		
• 6,35	1/4	8	90°		<b>815.064.11</b>			
9,5	3/8	12,7	90°	<b>715.095.11</b>	<b>815.095.11</b>	<b>915.095.11</b>		
12,7	1/2	12,7	90°	<b>715.127.11</b>	<b>815.127.11</b>	<b>915.127.11</b>		
16	5/8	12,7	90°			<b>915.160.11</b>	<b>915.660.11</b>	<b>815.660.11</b>
19	3/4	16	90°	<b>715.190.11</b>			<b>915.690.11</b>	<b>815.690.11</b>
<b>with top bearing</b>								
12,7	1/2	12,7	90°		<b>815.127.11B</b>			
16	5/8	12,7	90°			<b>915.160.11B</b>		
19	3/4	16	90°	<b>715.190.11B</b>				<b>815.690.11B</b>

Spare parts: **791.010.00** Ø12,7mm bearing  
**791.025.00** Ø16mm bearing  
**791.007.00** Ø19mm bearing with Ø6mm bore

**791.011.00** Ø19mm bearing with Ø12,7mm bore  
**541.003.00** Stop collar for Ø6mm shanks  
**541.001.00** Stop collar for Ø6,35mm shanks

**541.004.00** Stop collar for Ø8mm shanks  
**541.002.00** Stop collar for Ø12,7mm shanks  
**991.056.00** 1,5mm hex key

## V-Grooving bits (90°) for plasterboard



These double cutting edge CMT bits have been especially designed for routing and jointing 90° plasterboard panels but offer you many woodworking possibilities too; in fact make clean, perfect incisions in panels or drawer fronts; chamfer edges or engrave beautiful lettering. Like all CMT bits, they are made of super strength Fatigue Proof® steel with carbide-tipped cutting edges and are coated with our trademark orange PTFE non-stick coating.

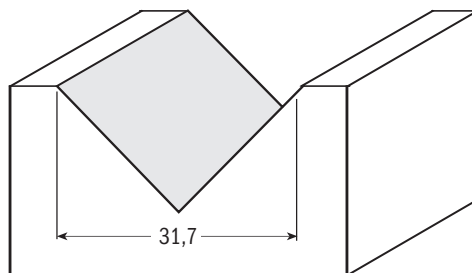

PLASTERBOARD PANEL

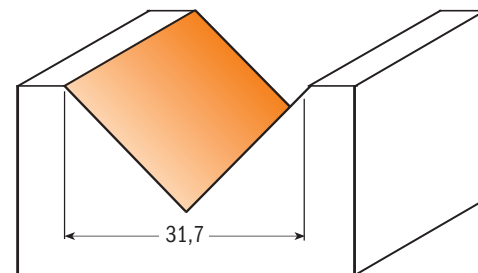

Drawings are 1:1 scale

D Cutting diameter		I Cutting length	A Cutting angle	ORDER NO. Shank Ø 8mm	ORDER NO. Shank Ø 12mm	ORDER NO. Shank Ø 12,7mm
31,7	1-1/4	16	90°	<b>915.317.11</b>	<b>915.817.11</b>	<b>815.817.11</b>

**7/8/958**

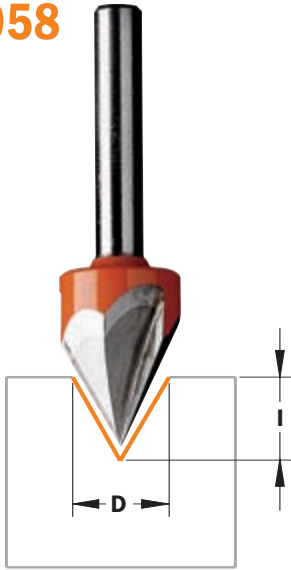

This new bit lets you make delicate grooves and incisions with laser precision. Make one of a kind effects with single run 30° bevel edges. Three super sharp cutting edges and this perfectly balanced bit allow you to work with superior accuracy with no risk of burning. Raise the bit and produce a delicate fine point incision, or work the whole 12,7mm diameter to render bold highlighted lettering. Super strong steel shank and micrograin carbide cutting edges guarantee long lasting performance.

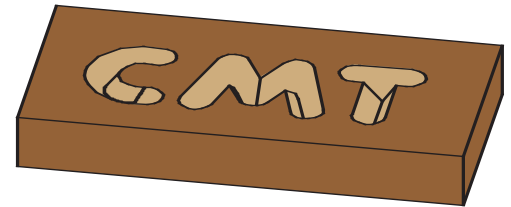
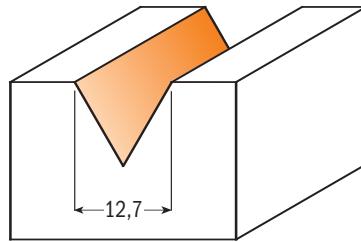

Drawings are 1:1 scale

D Cutting diameter		I Cutting length	A Cutting angle	ORDER NO. Shank Ø 6mm	ORDER NO. Shank Ø 6,35mm	ORDER NO. Shank Ø 8mm	ORDER NO. Shank Ø 12,7mm
12,7	1/2	11	60°	<b>758.001.11</b>	<b>858.001.11</b>	<b>958.001.11</b>	<b>858.501.11</b>

**Screw slot bits**



**813.601**  
**913.101**



Any large panel or table top should be secured in a way that allows it to expand or contract without splitting. These screw-slot bits let you create screw slots so that panels can be held in place but are able to slide back and forth without splitting the wood or breaking the screw securing them.

Both have 12mm or 12,7mm shanks and the codes 913.201.11 and 813.701.11 are for countersink screws, while the codes 913.101.11 and 813.601.11 are for counterbored screws.

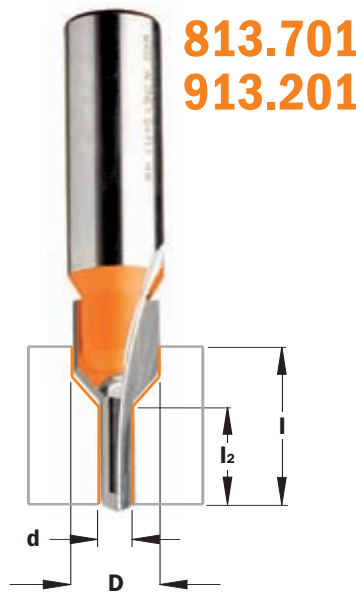
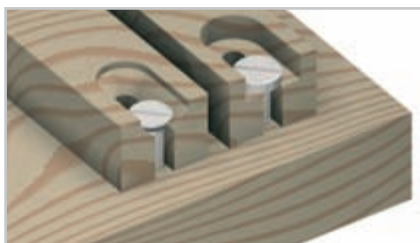
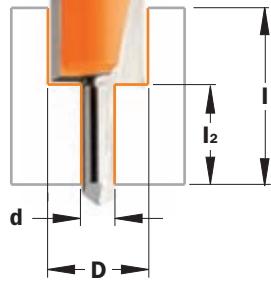

**813.701**  
**913.201**

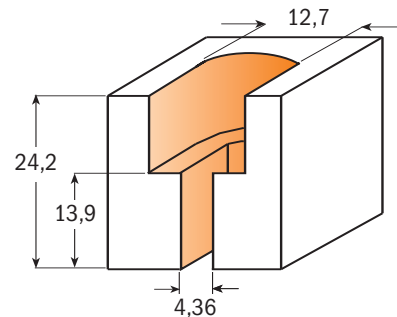

**813.601**  
**913.101**

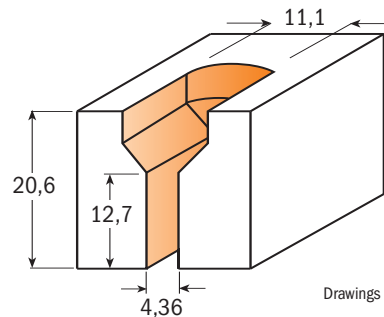

**813.701**  
**913.201**

Drawings are 1:1 scale

D Cutting diameter		d Small cutting diameter	I Cutting length	I <sub>2</sub> Cutting length	ORDER NO. Shank Ø 8mm	ORDER NO. Shank Ø 12,7mm
11,1	7/16	4,36	20,6	12,7	<b>913.201.11</b>	<b>813.701.11</b>
12,7	1/2	4,36	24,2	13,9	<b>913.101.11</b>	<b>813.601.11</b>



**8/949B**



The ideal bit for routing signs. CMT has designed a bit with a 60° curved profile, a 3,2mm (1/8") radius and a flattened bottom to make relief letter-making easy and accurate.

This exclusive design allows you to efficiently level off the area around the base of the letter and bevel the letter edges to eliminate aggravating splintering. Try our 60° lettering bit with top bearing guide to get even more precise decorative effects.



**7/8/949**

Drawings are 1:1 scale

D Cutting diameter mm inches	I Cutting length mm	A Cutting angle	Spare bearing	ORDER NO. Shank Ø 6mm	ORDER NO. Shank Ø 6,35mm	ORDER NO. Shank Ø 12mm	ORDER NO. Shank Ø 12,7mm
25,4 1	19	60°		<b>749.001.11</b>	<b>849.001.11</b>		
28	19	60°				<b>949.502.11</b>	
28,5 1-1/8	19	60°					<b>849.501.11</b>
<b>with top bearing</b>							
28	19	60°	791.026.00			<b>949.502.11B</b>	
28,5 1-1/8	19	60°	791.027.00				<b>849.501.11B</b>

**Spare parts:** 791.026.00 Ø28mm bearing  
791.027.00 Ø28,5mm bearing

541.005.00 Stop collar for Ø12mm shanks  
541.002.00 Stop collar for Ø12,7mm shanks

991.056.00 1,5mm hex key

## Bowl and tray bits

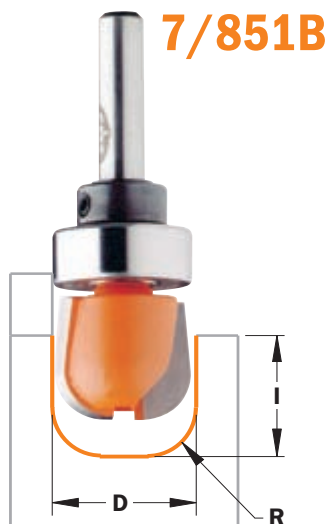

**7/851B**



This CMT bit is ideal for making bowls, trays, boxes, cutting boards or any other specialty or craft item. The round corner of the bit shapes the inner radius while the sides and bottom create the smooth flat surfaces. Makes pattern work quick and easy. For best results on jobs where accuracy is a priority we recommend using our top bearing bowl and tray bits shown at bottom of page. Bowl and Tray bits with top bearings are great for pattern work. Use them to create raised sign lettering, trays and many other items.



**7/8/951**

Drawings are 1:1 scale

D Cutting diameter mm inches	I Cutting length mm	R Radius mm	ORDER NO. Shank Ø 6mm	ORDER NO. Shank Ø 6,35mm	ORDER NO. Shank Ø 8mm	ORDER NO. Shank Ø 12mm	ORDER NO. Shank Ø 12,7mm
11,1 7/16	12,7	3,2		<b>851.001.11</b>			
19 3/4	16	6,4	<b>751.002.11</b>	<b>851.002.11</b>	<b>951.002.11</b>	<b>951.501.11</b>	<b>851.501.11</b>
31,7 1-1/4	16	6,4				<b>951.502.11</b>	<b>851.502.11</b>
<b>with top bearing</b>							
19 3/4	16	6,4	<b>751.002.11B</b>	<b>851.002.11B</b>			<b>851.501.11B</b>
31,7 1-1/4	16	6,4					<b>851.502.11B</b>

**Spare parts:** 791.007.00 Ø19mm bearing with Ø6mm bore  
791.004.00 Ø19mm bearing with Ø6,35mm bore  
791.011.00 Ø19mm bearing with Ø12,7mm bore

791.015.00 Ø31,7mm bearing  
541.003.00 Stop collar for Ø6mm shanks  
541.001.00 Stop collar for Ø6,35mm shanks

541.002.00 Stop collar for Ø12,7mm shanks  
991.056.00 1,5mm hex key

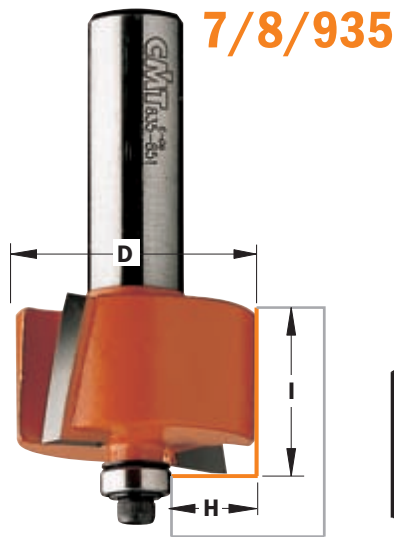

CMT carbide-faced rabbeting bits are fast and accurate - you can quickly produce inset doors and drawer fronts, make strong rabbet joints, mill perfect tongue and groove joints or any number of other jobs that before were time consuming and difficult. You can even re-groove old window frames to fit insulated glass panes with the extra long CMT 19mm (3/4") rabbeting bit. Other possibilities are illustrated below and on the following pages. Look at our slot cutters and round over bits for ideas on how to put extra finishing touches on all your grooving and rabbeting projects.

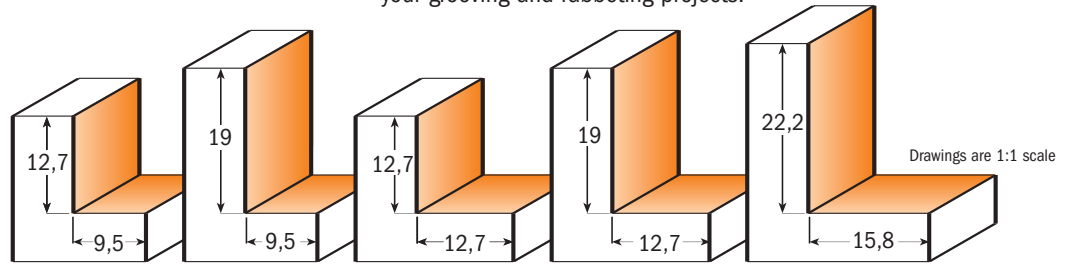

H Cutting depth		D Cutting diameter	I Cutting length	ORDER NO. Shank Ø 6mm	ORDER NO. Shank Ø 6,35mm	ORDER NO. Shank Ø 8mm	ORDER NO. Shank Ø 12mm	ORDER NO. Shank Ø 12,7mm
mm	inches	mm	mm					
9,5	3/8	31,7	12,7	<b>735.317.11</b>	<b>835.317.11</b>	<b>935.317.11</b>	<b>935.817.11</b>	<b>835.817.11</b>
9,5	3/8	31,7	19	<b>735.318.11</b>		<b>935.318.11</b>		
12,7	1/2	34,9	12,7	<b>735.350.11</b>	<b>835.350.11</b>	<b>935.350.11</b>	<b>935.850.11</b>	<b>835.850.11</b>
12,7	1/2	34,9	19				<b>935.851.11</b>	<b>835.851.11</b>
16	5/8	50,8	22				<b>935.990.11</b>	<b>835.990.11</b>

**Spare parts:** **791.002.00** Ø9,5mm bearing  
**791.003.00** Ø12,7mm bearing  
**791.010.00** Ø6,35-Ø12,7mm bearing (8/935.990.11)

**799.503.00** Bushings 19,05mm (8/935.990.11)  
**541.514.00** 2mm spacer (8/935.990.11)  
**990.422.00** Ø9,5mm shield  
**990.423.00** Ø12,7mm shield  
**990.058.00** 1/8W screw  
**991.057.00** 3/32" hex key

**Rabbeting sets**



CMT rabbeting sets allow you to make a limitless number of cuts by adjusting the cutting height on your router and changing the bearing on the bit.

**BE SURE** to keep the black bearing washer right side up to correspond with the bearing rotation when re-assembling the bearing. Improper re-assembly can cause the screw to come loose. Each set comes complete with one rabbeting bit and six interchangeable ball bearing guides.

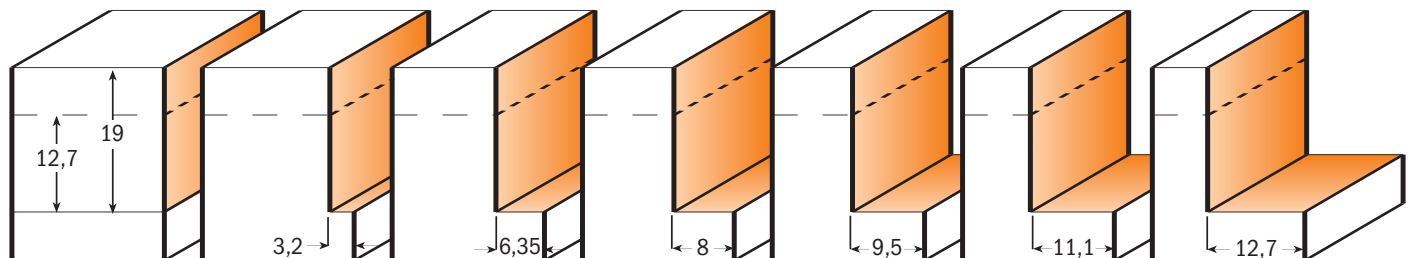

H Cutting depth		D Cutting diameter	I Cutting length	ORDER NO. Shank Ø 6mm	ORDER NO. Shank Ø 6,35mm	ORDER NO. Shank Ø 8mm	ORDER NO. Shank Ø 12mm	ORDER NO. Shank Ø 12,7mm
mm	inches	mm	mm					
0-12,7	0-1/2	34,9	12,7	<b>735.001.11</b>	<b>835.001.11</b>	<b>935.001.11</b>	<b>935.501.11</b>	<b>835.501.11</b>
0-12,7	0-1/2	34,9	19				<b>935.502.11</b>	<b>835.502.11</b>



**8/935.503**



Your choice of "The Grand Rabbet" by CMT is an investment that shows your commitment to quality. This CMT product will deliver years of reliable service under normal use. For safe and trouble-free results please observe the following instructions and safety precautions.

The complete kit (item code 835-935.503.11), will enable you to produce 17 different rabbet sizes including rabbets for under-size plywood applications. For rabbet sizes over 12,7mm (1/2"), make the cuts in several shallow passes until the desired depth is achieved.

Available in 12 and 12,7mm shanks.

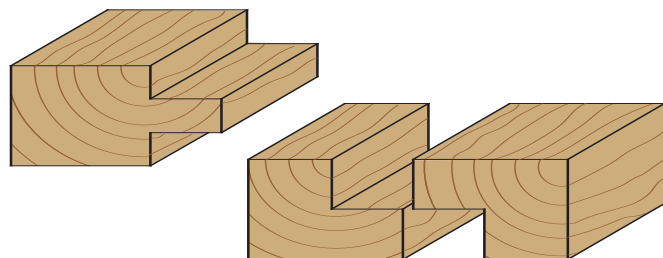

**8/935-990**

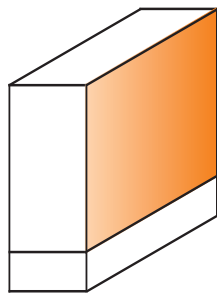

Flush trim with collar  
799.517.00

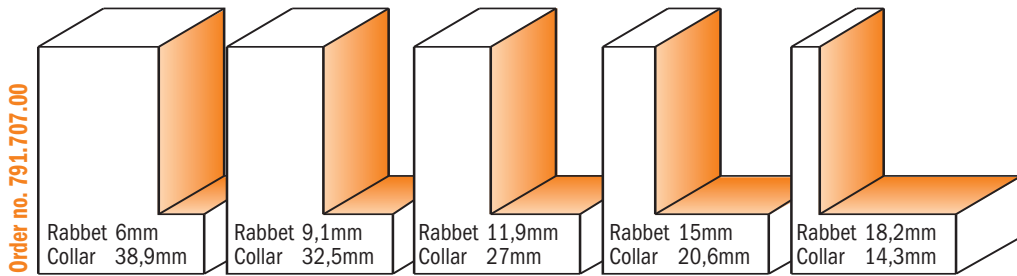
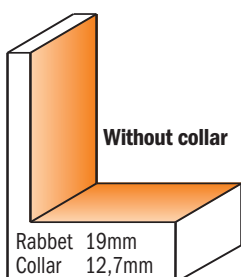
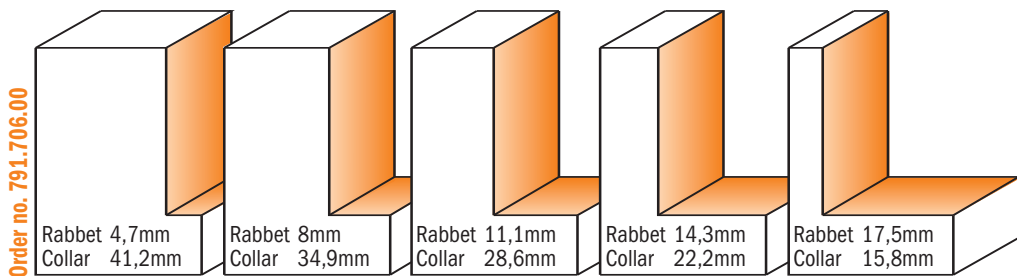
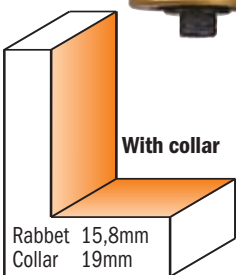
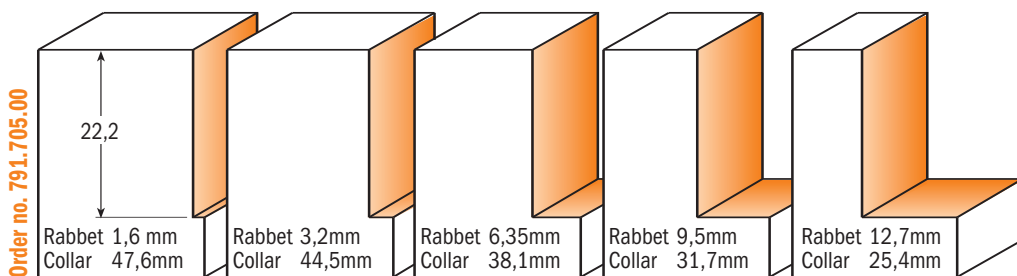

Drawings are 1:1 scale

DESCRIPTION	ORDER NO. Shank Ø 12mm	ORDER NO. Shank Ø 12,7mm
The CMT grand rabbet set	<b>935.503.11</b>	<b>835.503.11</b>
<b>SET CONTAINS:</b> The grand rabbet (bit only) Ø19mm	<b>935.990.11</b>	<b>835.990.11</b>
5 pcs. collar set (1,6 - 3,2 - 6,35 - 9,5 - 12,7mm rabbets)		<b>791.705.00</b>
5 pcs. collar set (4,7 - 8 - 11,1 - 14,3 - 17,5mm rabbets)		<b>791.706.00</b>
5 pcs. collar set (6 - 9,1 - 11,9 - 15 - 18,2mm rabbets)		<b>791.707.00</b>
Kit with screws, shields and keys		<b>990.452.00</b>

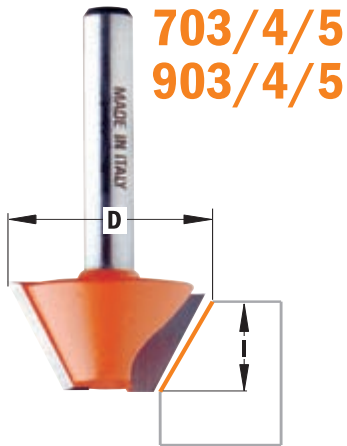

From a gently beveled edge to decorative chamfers in a variety of materials, CMT offers smooth results.

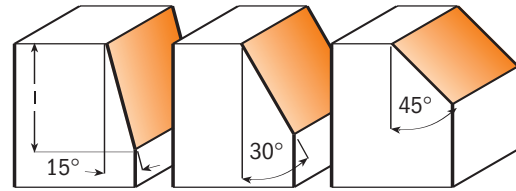

Drawings are 1:1 scale

A Cutting angle	D Cutting diameter mm	I Cutting length mm	L Cutting length mm	ORDER NO. Shank Ø 6mm	ORDER NO. Shank Ø 8mm
15°	24	14	46	<b>703.240.11</b>	<b>903.240.11</b>
30°	26	12,7	44,5	<b>704.240.11</b>	<b>904.240.11</b>
45°	25	8	41	<b>705.240.11</b>	<b>905.240.11</b>

**Bevel cutters for Corian®**



**8/966.5**



Special angled Delrin® sleeve on the bearing of the CMT bevel cutter lets you work without leaving marks on the workpiece. Trims and shapes all wood and wood materials. Perfect for kitchen and bathroom counter top work.

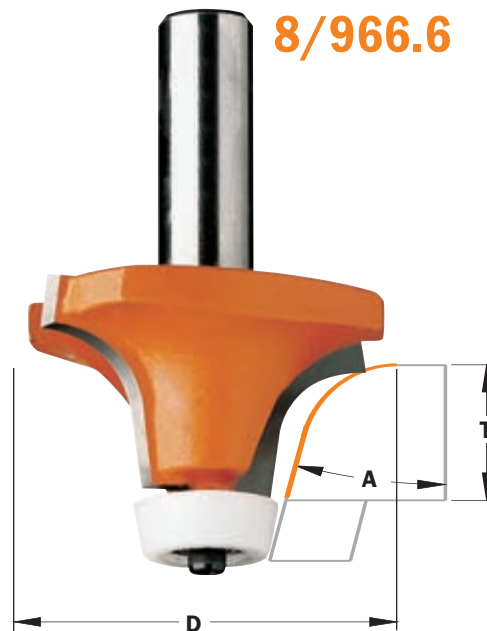

**8/966.6**

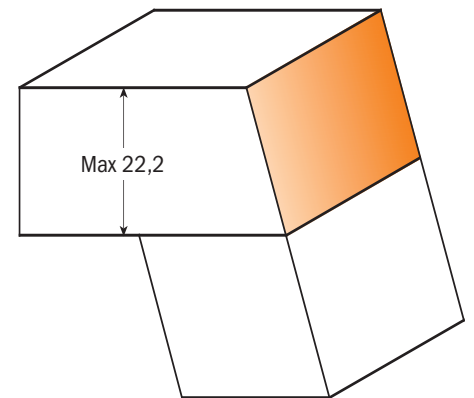

Drawings are 1:1 scale

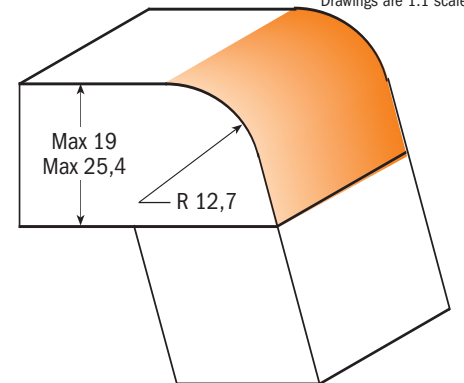

A Cutting angle	D Cutting diameter mm inches	I Cutting length mm	T Max stock thickness mm	R Radius mm	ORDER NO. Shank Ø 12mm	ORDER NO. Shank Ø 12,7mm
15°	31,7 1-1/4	22,2			<b>966.501.11</b>	<b>866.501.11</b>
15°	50,8 2	25,4	19	12,7	<b>966.601.11</b>	<b>866.601.11</b>
15°	50,8 2	31,75	25,4	12,7	<b>966.602.11</b>	<b>866.602.11</b>

Spare parts: **791.041.00** Ø19mm bearing

**990.058.00** 1/8W screw

**991.057.00** 3/32" hex key

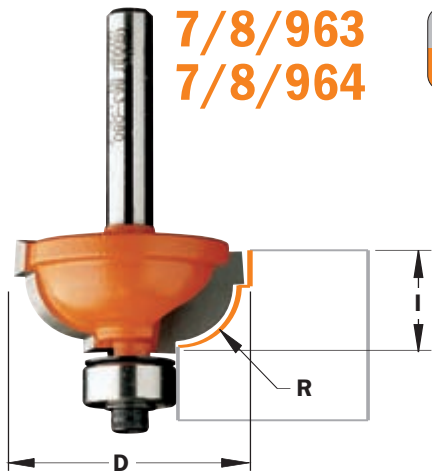

7/8/963  
7/8/964



The Cavetto bit cuts a beautiful, traditional profile, or use just a portion of the bit to cut a more simple, clean cove edge. Adds a special touch to furniture pieces. Makes a traditional cove profile with top and bottom fillet grooves in all woods and wood composites.

**Important:** Always assemble the black bearing heat shield with the raised side up when changing the bearing. Improper assembly will cause the screw to come loose and the bearing to fall off when routing.

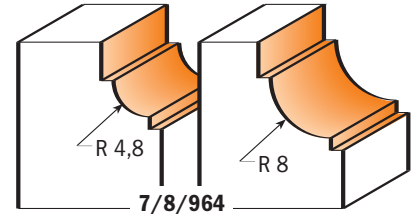
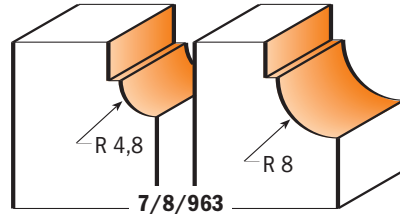

R Radius	D Cutting diameter	I Cutting length	ORDER NO.		ORDER NO.		ORDER NO.	
			Shank Ø 6mm	Shank Ø 6,35mm	Shank Ø 8mm	Shank Ø 12mm	Shank Ø 12,7mm	
4,8 3/16	25,4	11,5	763.048.11	863.048.11	963.048.11	963.548.11	863.548.11	
8 5/16	31,7	14,3	763.080.11	863.080.11	963.080.11	963.580.11	863.580.11	
4,8 3/16	25,4	11,5	764.048.11	864.048.11	964.048.11	964.548.11	864.548.11	
8 5/16	31,7	14,3	764.080.11	864.080.11	964.080.11	964.580.11	864.580.11	

**Spare parts:** 990.422.00 Ø9,5mm shield  
791.002.00 Ø9,5mm bearing

990.423.00 Ø12,7mm shield  
791.003.00 Ø12,7mm bearing

990.058.00 1/8W screw  
991.057.00 3/32" hex key

## Ovolo bits

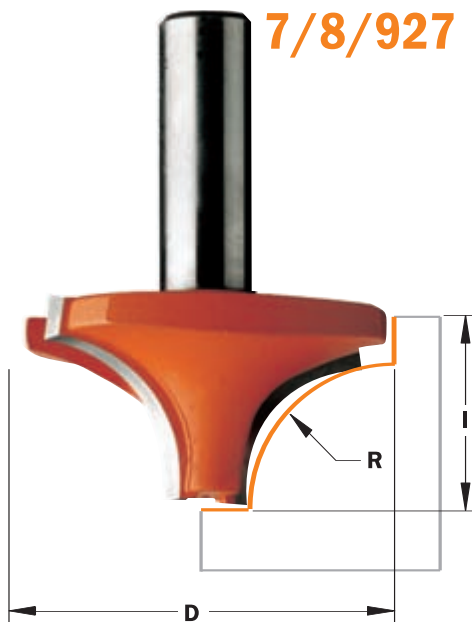

7/8/927



CMT put the work capacity of several different bits all into one. The perfect bit for furniture makers, the CMT ovolo allows you to make beautiful beadwork, edgework and veins. Use these bits on automated router systems or with a fence to produce a wide variety of single and double bead profiles and roundovers like those illustrated below by simply adjusting the height or depth of the cut.

**Safety tips:** Pay particular attention to never rush the job when using a large profile bit. Mill pieces with a fence mounted on the work table to insure maximum protection.

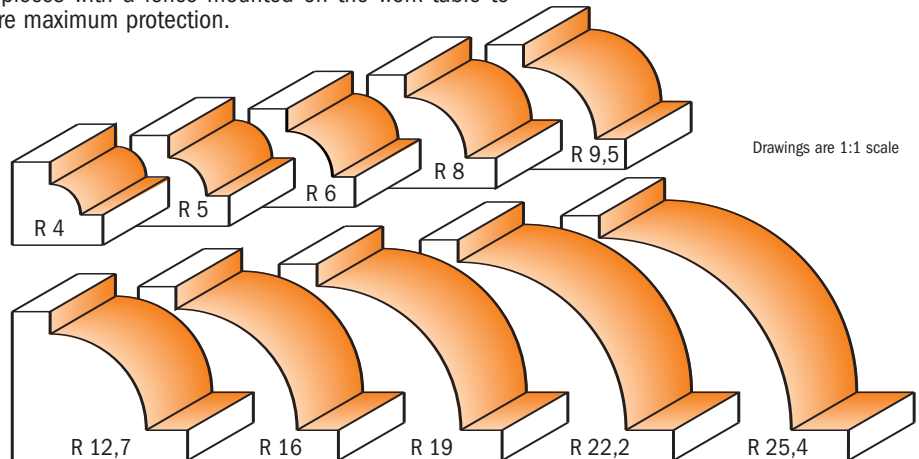

Drawings are 1:1 scale

R Radius	D Cutting diameter	I Cutting length	ORDER NO.		ORDER NO.		ORDER NO.	
			Shank Ø 6mm	Shank Ø 6,35mm	Shank Ø 8mm	Shank Ø 12mm	Shank Ø 12,7mm	
4	19	12	727.040.11		927.040.11			
5 3/16	21	12	727.050.11	827.050.11	927.050.11			
6 15/64	23	12	727.060.11	827.060.11	927.060.11		827.560.11	
8	28,6	12,7	727.080.11		927.080.11			
9,5 3/8	31,7	14	727.095.11	827.095.11	927.095.11	927.595.11	827.595.11	
12,7 1/2	38,1	19		827.127.11		927.627.11	827.627.11	
16 5/8	44,5	22,2				927.660.11	827.660.11	
19 3/4	50,8	25,4				927.690.11	827.690.11	
22,2 7/8	57,1	28,5				927.722.11	827.722.11	
25,4 1	63,5	33,3				927.754.11	827.754.11	

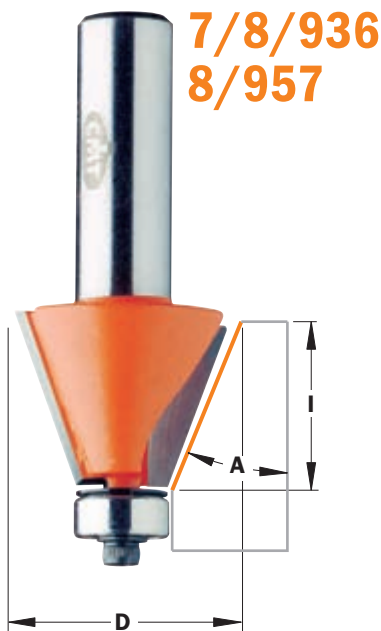

**7/8/936**  
**8/957**



CMT Chamfer bits cut clean, accurate bevels and chamfers that are great for edge work or to make perfectly aligned multi-sided containers, boxes and other decorative projects. See illustration below for examples. Can be used to work larger scale projects such as beams and columns with excellent results.

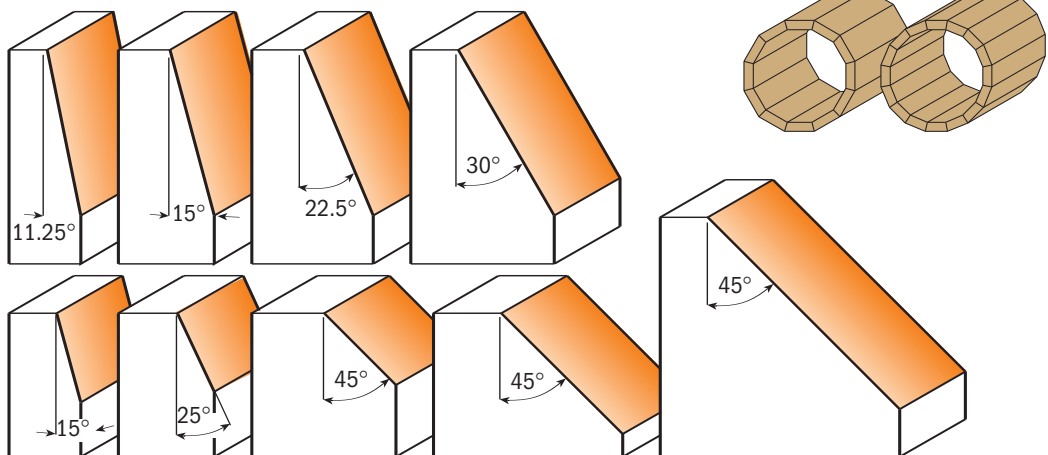

Drawings are 1:1 scale

A Cutting angle	D Cutting diameter		I Cutting length mm	ORDER NO.	ORDER NO.	ORDER NO.	ORDER NO.	ORDER NO.
	mm	inches		Shank Ø 6mm	Shank Ø 6,35mm	Shank Ø 8mm	Shank Ø 12mm	Shank Ø 12,7mm
15°	19	3/4	11,5	<b>736.130.11</b>	<b>836.130.11</b>	<b>936.130.11</b>		
25°	22,2	7/8	10	<b>736.190.11</b>	<b>836.190.11</b>	<b>936.190.11</b>		
45°	31,7	1-1/4	9,5	<b>736.280.11</b>	<b>836.280.11</b>	<b>936.280.11</b>		
45°	45	1-3/4	18	<b>736.420.11</b>	<b>836.420.11</b>	<b>936.420.11</b>	<b>936.920.11</b>	<b>836.920.11</b>
45°	65	2-9/16	26				<b>936.950.11</b>	<b>836.950.11</b>
11,25°	21,5	7/8	22				<b>957.504.11</b>	<b>857.504.11</b>
15°	24,5	1	22				<b>957.503.11</b>	<b>857.503.11</b>
22,5°	31	1-1/4	22				<b>957.502.11</b>	<b>857.502.11</b>
30°	38,5	1-1/2	22				<b>957.501.11</b>	<b>857.501.11</b>

**Spare parts:** 990.423.00 Ø12,7mm shield      791.003.00 Ø12,7mm bearing      990.058.00 1/8W screw      991.057.00 3/32" hex key



**Chamfer set**



Build beautiful planters, boxes and other multi-sided pieces with this handy set. Why cut imperfect angles on your table saw when it's so much easier and accurate to use the CMT Chamfer set? Our solution to accurate polygon construction includes 5 anti-kickback, carbide tipped bits in the most popular angles - 11-1/4°, 15°, 22-1/2°, 30° and 45°. No polygon project is too difficult. Available with 12,7mm shank.

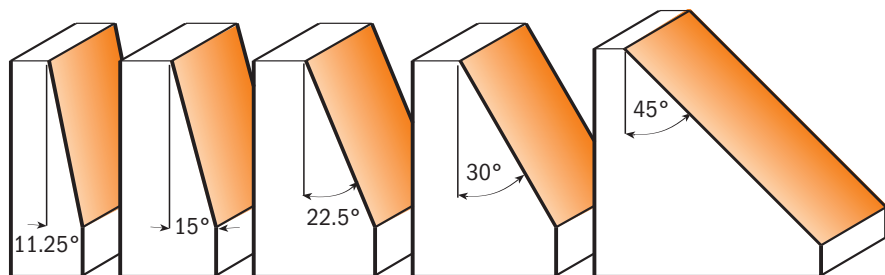

Drawings are 1:1 scale

DESCRIPTION	ORDER NO. Shank Ø 12,7mm
Chamfer set	<b>836.501.11</b>



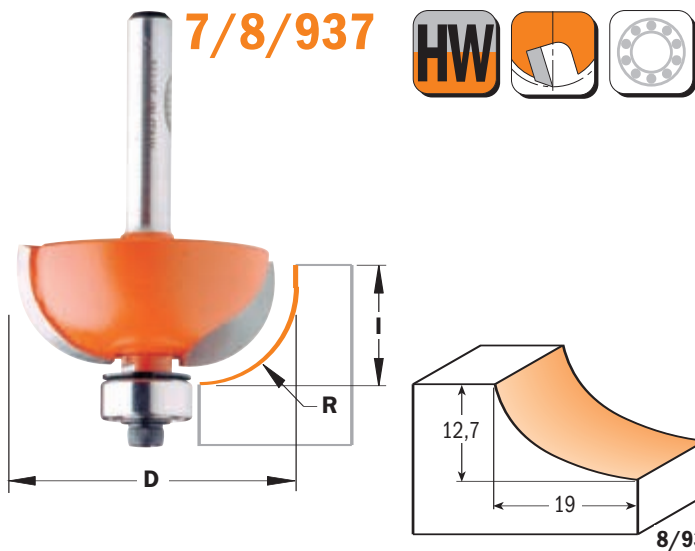

You can make furniture, doors, and drawer fronts that go from simple to elegant by giving them a final touch with a CMT cove bit. Put them together with a CMT roundover bit and construct perfectly fitting rule joints that are ideal for drop leaf counter and table tops. These bits are made of Fatigue Proof® steel and have carbide-tipped cutting edges, anti-kickback design and CMT trademark bright orange PTFE non-stick coating.

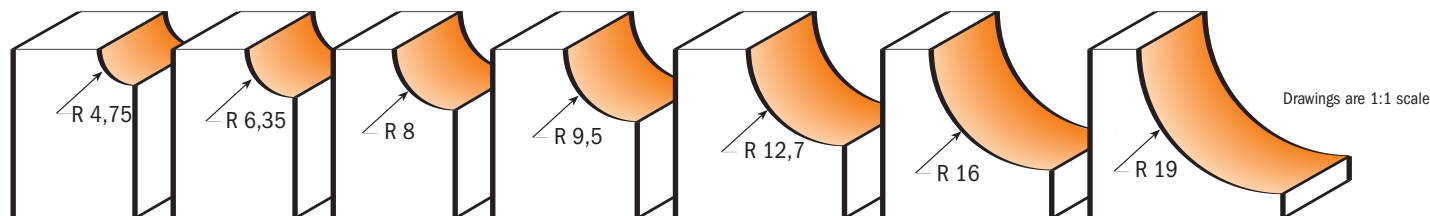
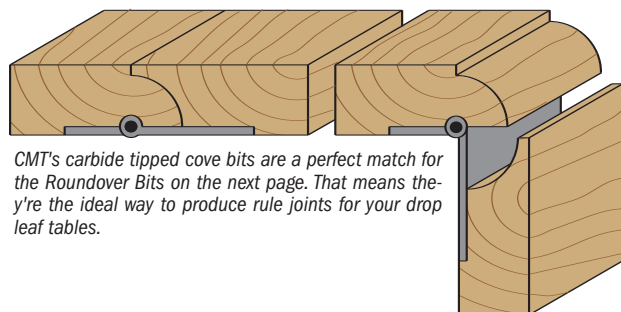

R Radius	D Cutting diameter	I Cutting length	ORDER NO.		ORDER NO.		ORDER NO.	
			Shank Ø 6mm	Shank Ø 6,35mm	Shank Ø 8mm	Shank Ø 12mm	Shank Ø 12,7mm	
4,75	22,2	12,7	737.190.11	837.190.11	937.190.11	937.690.11	837.690.11	
6,35	25,4	12,7	737.222.11	837.222.11	937.222.11	937.722.11	837.722.11	
8	28,7	12,7	737.254.11	837.254.11	937.254.11	937.754.11	837.754.11	
9,5	31,7	12,7	737.286.11	837.286.11	937.286.11	937.786.11	837.786.11	
12,7	38,1	15,5	737.350.11	837.350.11	937.350.11	937.850.11	837.850.11	
16	44,5	18,5				937.950.11	837.950.11	
19	50,8	22,2				937.951.11	837.951.11	
	50,8	12,7				937.955.11	837.955.11	

Spare parts: 990.423.00 Ø12,7mm shield      791.003.00 Ø12,7mm bearing      990.058.00 1/8W screw      991.057.00 3/32" hex key

## Cove bit set



See simple furniture, doors and drawer fronts transform into elegant pieces by giving them a final touch with a CMT Cove Bit. Pair them up with CMT Roundover Bits and make beautiful rule joints to create drop leaf counter and table tops. Anti-kickback design and thick carbide tips for long lasting performance. Available with a 12,7mm or 6,35mm shank. Cove radii are 6,35mm, 9,5mm and 12,7mm.

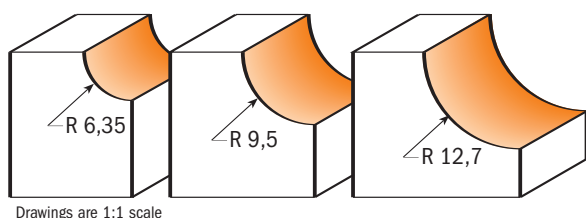

DESCRIPTION	ORDER NO. Shank Ø 6,35mm	ORDER NO. Shank Ø 12,7mm
Cove bit set	837.001.11	837.501.11

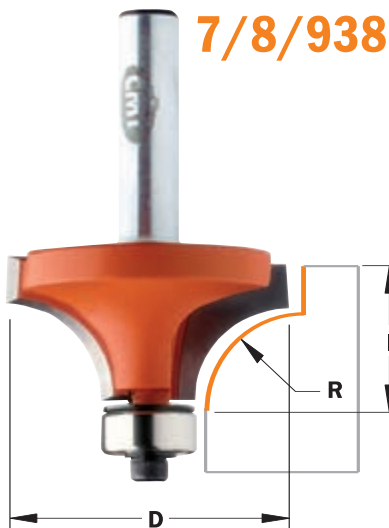

The smaller bearing on the CMT Beading bits makes a delicate inset at the base of the cut, giving you the advantage of an extra decorative option.

Simply change the bearing on your roundover bit to create a bead profile.

BE SURE to keep the black bearing washer right side up to correspond with the bearing rotation when reassembling the bearing. Improper reassembly can cause the bit to unscrew.

All CMT roundover bits have a 12,7mm bearing diameter with the exception of the radius 28,6mm and 31,7mm bits which have a 19mm bearing diameter. You have 13 different radii to choose from, the majority having 5 shank diameter options. All bits are made of Fatigue Proof® steel and have carbide-tipped cutting edges.

**Shop Tips:** The CMT 1.6mm radius roundover bit is excellent for finishing laminates. Virtually eliminates the filing required when using conventional trim bits.

**Safety Tips:** Use caution when working with large diameter bits and make more than one pass to gradually remove stock. Pay particular attention when routing small pieces; and always rout on a router table equipped with a fence.

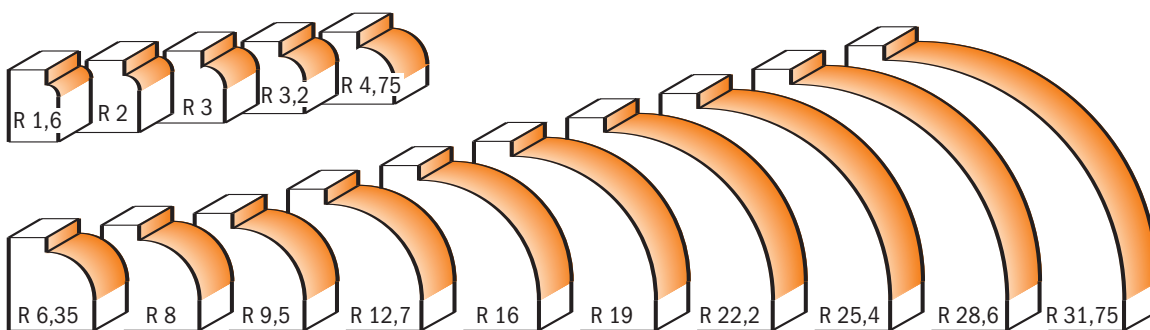

Drawings are 1:1 scale

R Radius	D Cutting diameter	I Cutting length	ORDER NO.				
			Shank Ø 6mm	Shank Ø 6,35mm	Shank Ø 8mm	Shank Ø 12mm	Shank Ø 12,7mm
1,6	15,9	12,7	738.160.11	838.160.11	938.160.11		
2	16,7	12,7	738.167.11		938.167.11		
3	18,7	12,7	738.187.11		938.187.11		
3,2	19,1	12,7	738.190.11	838.190.11	938.190.11		
4,75	22,2	12,7	738.222.11	838.222.11	938.222.11		
6,35	25,4	12,7	738.254.11	838.254.11	938.254.11	938.754.11	838.754.11
8	28,6	12,7	738.285.11	838.285.11	938.285.11		
9,5	31,7	14	738.317.11	838.317.11	938.317.11	938.817.11	838.817.11
12,7	38,1	19	738.380.11	838.380.11	938.380.11	938.880.11	838.880.11
16	44,5	22		838.445.11	938.445.11	938.945.11	838.945.11
19	50,8	25,4				938.990.11	838.990.11
22,2	57,1	28,5				938.991.11	838.991.11
25,4	63,5	33,3				938.992.11*	838.992.11*
28,6	76,2	38,1				938.993.11*	838.993.11*
31,75	82,5	44,4				938.994.11*	838.994.11*
38,1	88,9	44,4				938.996.11*	838.996.11*

**Spare parts:** 990.423.00 Ø12,7mm shield  
541.550.00 Ø9mm spacer

791.003.00 Ø12,7mm bearing  
791.004.00 Ø19mm bearing

990.058.00 1/8W screw

991.057.00 3/32" hex key

\* Use only on router table

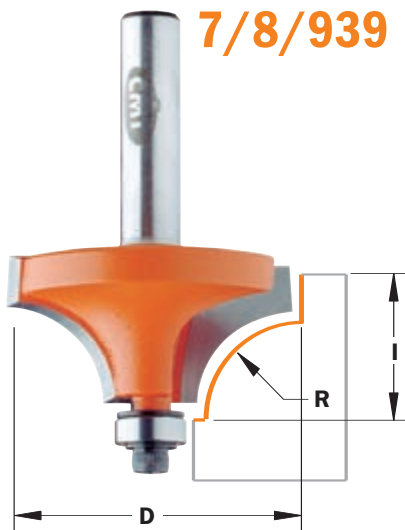

Beading bits are similar to the roundover profile, but a smaller bearing produces a delicate inset at the base of the cut, giving you an extra decorative option.

For a beading profile (code 7/8/939) simply change the bearing (**791.002.00**) on your roundover bits (code 7/8/938).

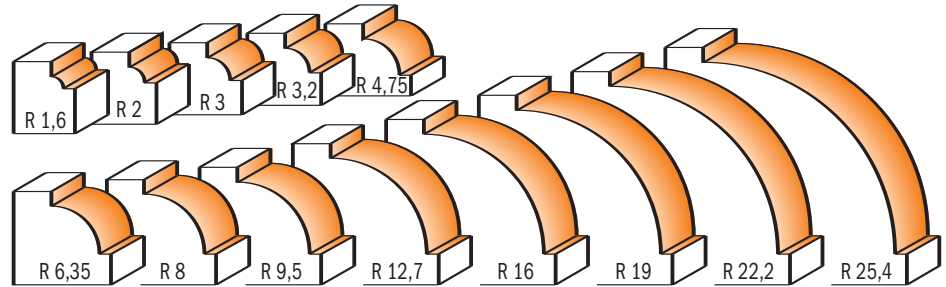

Drawings are 1:1 scale

R Radius	D Cutting diameter	I Cutting length	ORDER NO.	ORDER NO.	ORDER NO.	ORDER NO.	ORDER NO.
			Shank Ø 6mm	Shank Ø 6,35mm	Shank Ø 8mm	Shank Ø 12mm	Shank Ø 12,7mm
1,6	15,9	12,7	<b>739.160.11</b>	<b>839.160.11</b>	<b>939.160.11</b>		
2	16,7	12,7			<b>939.167.11</b>		
3	18,7	12,7			<b>939.187.11</b>		
3,2	19,1	12,7	<b>739.190.11</b>	<b>839.190.11</b>	<b>939.190.11</b>		
4,75	22,2	12,7	<b>739.222.11</b>	<b>839.222.11</b>	<b>939.222.11</b>		
6,35	25,4	12,7	<b>739.254.11</b>	<b>839.254.11</b>	<b>939.254.11</b>	<b>939.754.11</b>	<b>839.754.11</b>
8	28,6	12,7	<b>739.285.11</b>	<b>839.285.11</b>	<b>939.285.11</b>		
9,5	31,7	14	<b>739.317.11</b>	<b>839.317.11</b>	<b>939.317.11</b>	<b>939.817.11</b>	<b>839.817.11</b>
12,7	38,1	19	<b>739.380.11</b>	<b>839.380.11</b>	<b>939.380.11</b>	<b>939.880.11</b>	<b>839.880.11</b>
16	44,5	22		<b>839.445.11</b>	<b>939.445.11</b>	<b>939.945.11</b>	<b>839.945.11</b>
19	50,8	25,4				<b>939.990.11</b>	<b>839.990.11</b>
22,2	57,1	28,5				<b>939.991.11</b>	<b>839.991.11</b>
25,4	63,5	33,3				<b>939.992.11 *</b>	<b>839.992.11 *</b>

Spare parts: **990.422.00** Ø9,5mm shield

**791.002.00** Ø9,5mm bearing

**990.058.00** 1/8W screw

**991.057.00** 3/32" hex key

\* Use only on router table

## Roundover set



CMT's Roundover Sets give you the maximum flexibility for all of your projects by putting the most requested diameters in one package. Available in 12,7mm and 6,35mm shanks. Roundover radii are 6,35mm, 9,5mm and 12,7mm. These versatile bits are always in demand - the simple clean lines of a smooth roundover edge can be used in a wide variety of applications from picture frames to table and counter tops.

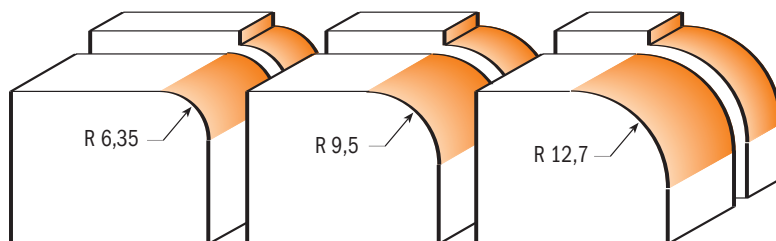

Drawings are 1:1 scale



DESCRIPTION	ORDER NO. Shank Ø 6,35mm	ORDER NO. Shank Ø 12,7mm
Roundover set	<b>838.001.11</b>	<b>838.501.11</b>



7/8/954



CMT bull nose bits give you beautifully finished edges on stair treads, window sills and shelves in one clean cut.

For an added touch, try using a cutter with a bead diameter wider than the stock thickness. CMT bull nose bits have bead diameters that range from 6,35mm (1/4") to 25,4mm (1") and all bits have carbide-tipped cutting edges, anti-kickback design and the trademark orange PTFE non-stick coating.

**Safety tips:** Must be used on a router table equipped with a fence. Do not remove the work piece while the bit is still rotating.

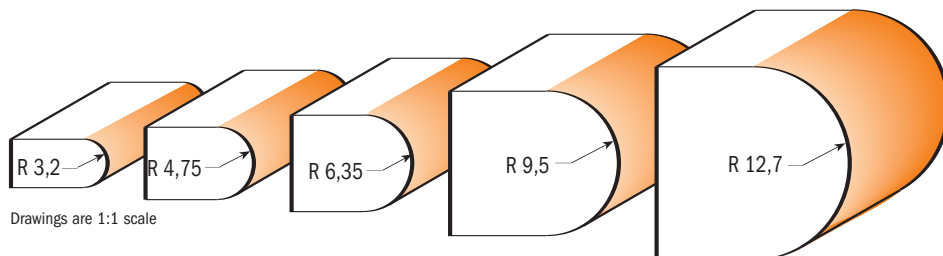

Drawings are 1:1 scale

R Radius mm	D Cutting diameter mm	B Profile height mm	I Cutting length mm	ORDER NO. Shank Ø 6mm	ORDER NO. Shank Ø 6,35mm	ORDER NO. Shank Ø 8mm	ORDER NO. Shank Ø 12mm	ORDER NO. Shank Ø 12,7mm
3,2	22,2	6,56	19	754.002.11	854.002.11	954.002.11	954.502.11	854.502.11
4,75	25,4	9,85	22	754.003.11	854.003.11	954.003.11	954.503.11	854.503.11
6,35	28,6	13,15	25,5	754.004.11	854.004.11	954.004.11	954.504.11	854.504.11
9,5	34,9	19,71	35				954.507.11	854.507.11
12,7	44,5	26,30	41				954.509.11	854.509.11

### Corner beading bits

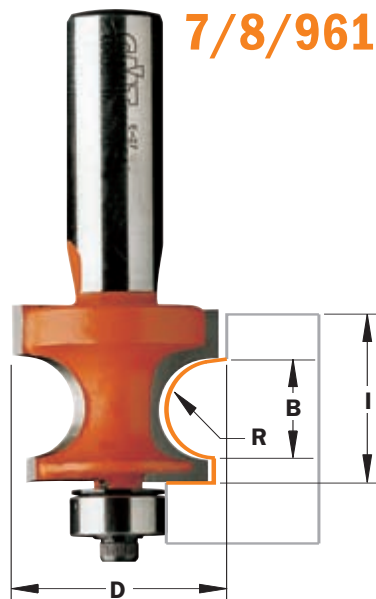

7/8/961



Mill beautiful traditional beads and edge beads or turn old beads into new molding with the new CMT corner beading bits with bearings. Carbide-tipped cutting edges and non-stick coated with our trademark orange PTFE, these bits give you excellent results on corner beads. You will want to run the bead twice to form a complete corner bead.

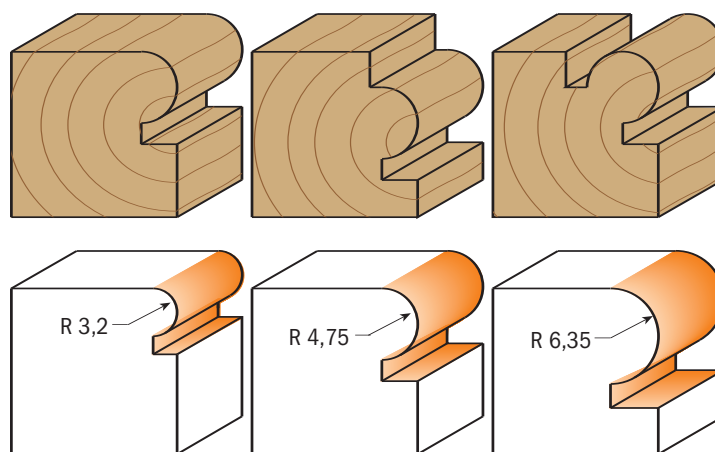

Drawings are 1:1 scale

R Radius mm	D Cutting diameter mm	B Profile height mm	I Cutting length mm	ORDER NO. Shank Ø 6mm	ORDER NO. Shank Ø 6,35mm	ORDER NO. Shank Ø 8mm	ORDER NO. Shank Ø 12mm	ORDER NO. Shank Ø 12,7mm
3,2	22,2	6,50	15	761.032.11	861.032.11	961.032.11	961.532.11	861.532.11
4,75	25,4	9,68	18,6	761.048.11	861.048.11	961.048.11	961.548.11	861.548.11
6,35	28,6	12,86	22,2	761.064.11	861.064.11	961.064.11	961.564.11	861.564.11

Spare parts: 990.423.00 Ø12,7mm shield

791.003.00 Ø12,7mm bearing

990.058.00 1/8W screw

991.057.00 3/32" hex key



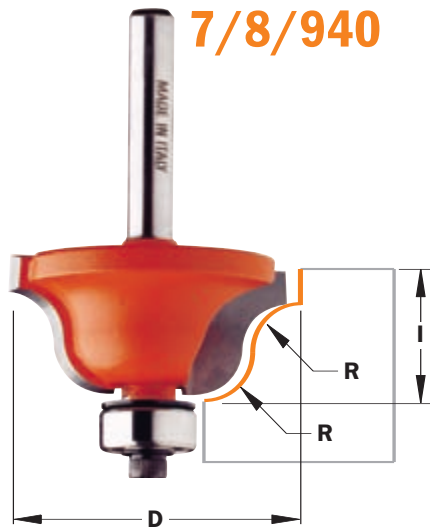

The roman ogee may be the most popular edge treatment in wood-working, and it is certainly one of the most beautiful. The CMT Roman Ogee bit brings all of the great CMT features to this tool, producing a perfect rendition of a classic design.

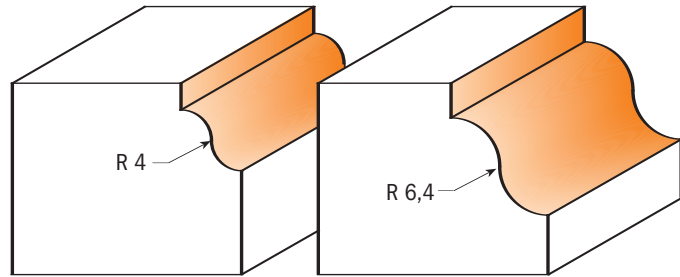

Drawings are 1:1 scale

R Radius		D Cutting diameter	I Cutting length	ORDER NO. Shank Ø 6mm	ORDER NO. Shank Ø 6,35mm	ORDER NO. Shank Ø 8mm	ORDER NO. Shank Ø 12mm	ORDER NO. Shank Ø 12,7mm
mm	inches	mm	mm					
4	5/32	28,7	11,5	<b>740.270.11</b>	<b>840.270.11</b>	<b>940.270.11</b>	<b>940.770.11</b>	<b>840.770.11</b>
6,4	1/4	38,1	17,3	<b>740.350.11</b>	<b>840.350.11</b>	<b>940.350.11</b>	<b>940.850.11</b>	<b>840.850.11</b>

**Spare parts:** 990.423.00 Ø12,7mm shield      791.003.00 Ø12,7mm bearing      990.058.00 1/8W screw      991.057.00 3/32" hex key

# Classical ogee bits

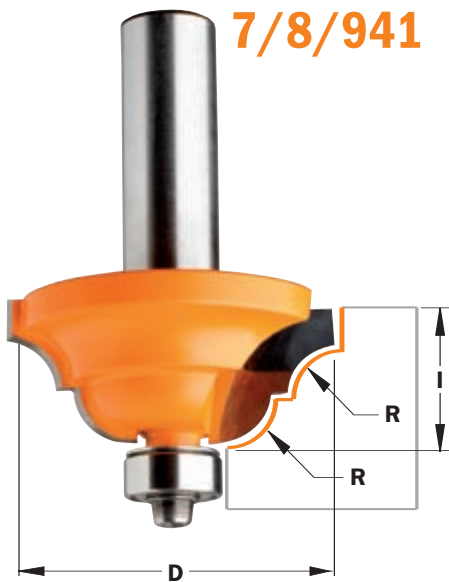

This bit takes the roman ogee a step further, with a horizontal bead to add more interest to the shape.

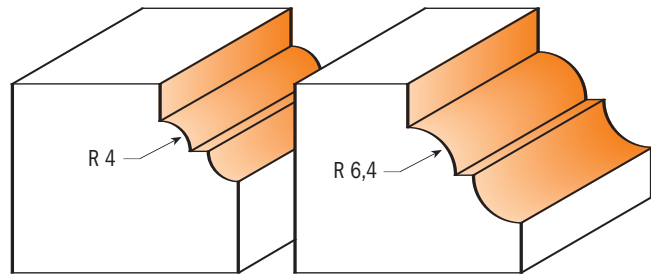

Drawings are 1:1 scale

R Radius		D Cutting diameter	I Cutting length	ORDER NO. Shank Ø 6mm	ORDER NO. Shank Ø 6,35mm	ORDER NO. Shank Ø 8mm	ORDER NO. Shank Ø 12mm	ORDER NO. Shank Ø 12,7mm
mm	inches	mm	mm					
4	5/32	33,4	13	<b>741.285.11</b>	<b>841.285.11</b>	<b>941.285.11</b>	<b>941.785.11</b>	<b>841.785.11</b>
6,4	1/4	42,8	18,5	<b>741.380.11</b>	<b>841.380.11</b>	<b>941.380.11</b>	<b>941.880.11</b>	<b>841.880.11</b>

**Spare parts:** 990.423.00 Ø12,7mm shield      791.003.00 Ø12,7mm bearing      990.058.00 1/8W screw      991.057.00 3/32" hex key

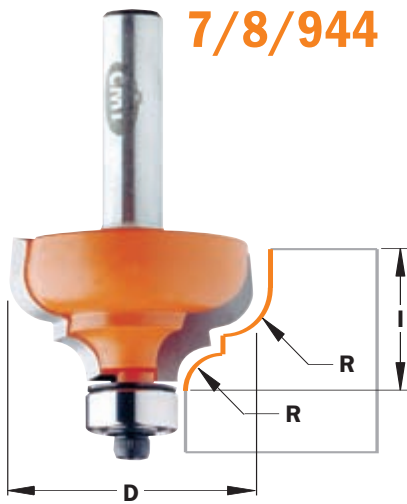

CMT's Classical Ogee Bits feature an inverted ogee profile, with the concave edge adjacent to the upper surface of the workpiece. Then we add a vertical bead to separate the curves, creating an eye-catching shape.

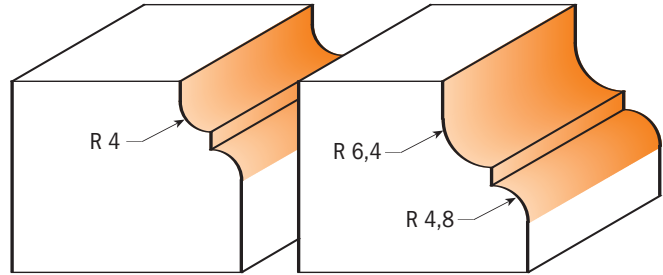

Drawings are 1:1 scale

R Radius	D Cutting diameter	I Cutting length	ORDER NO. Shank Ø 6mm	ORDER NO. Shank Ø 6,35mm	ORDER NO. Shank Ø 8mm	ORDER NO. Shank Ø 12mm	ORDER NO. Shank Ø 12,7mm
4 mm / 5/32 inches	28,7 mm	13 mm	<b>744.287.11</b>	<b>844.287.11</b>	<b>944.287.11</b>	<b>944.787.11</b>	<b>844.787.11</b>
6,4 - 4,8 mm / 1/4-3/16 inches	35 mm	18,5 mm	<b>744.350.11</b>	<b>844.350.11</b>	<b>944.350.11</b>	<b>944.850.11</b>	<b>844.850.11</b>

**Spare parts:** 990.423.00 Ø12,7mm shield      791.003.00 Ø12,7mm bearing      990.058.00 1/8W screw      991.057.00 3/32" hex key

**Classical ogee bits**

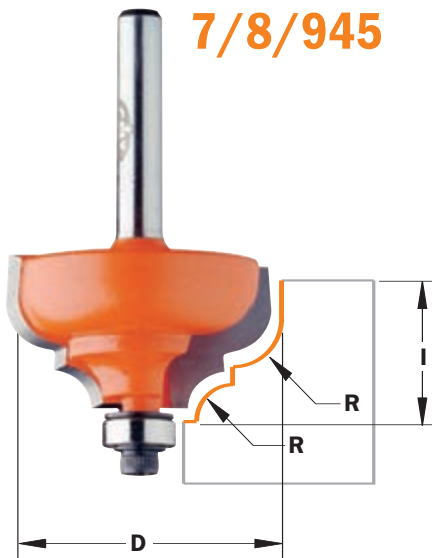

These bits add yet another detail to the ogee design of the bits above. To further define the edge, this profile includes a horizontal bead along the bottom of the cut.

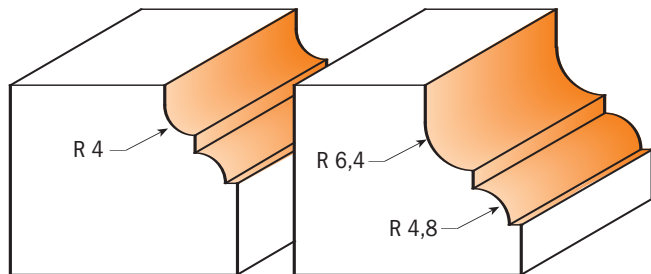

Drawings are 1:1 scale

R Radius	D Cutting diameter	I Cutting length	ORDER NO. Shank Ø 6mm	ORDER NO. Shank Ø 6,35mm	ORDER NO. Shank Ø 8mm	ORDER NO. Shank Ø 12mm	ORDER NO. Shank Ø 12,7mm
4 mm / 5/32 inches	28,7 mm	13 mm	<b>745.287.11</b>	<b>845.287.11</b>	<b>945.287.11</b>	<b>945.787.11</b>	<b>845.787.11</b>
6,4 - 4,8 mm / 1/4-3/16 inches	35 mm	18,5 mm	<b>745.350.11</b>	<b>845.350.11</b>	<b>945.350.11</b>	<b>945.850.11</b>	<b>845.850.11</b>

**Spare parts:** 990.422.00 Ø9,5mm shield      791.002.00 Ø9,5mm bearing      990.058.00 1/8W screw      991.057.00 3/32" hex key

7/8/946



Give your shop a full range of options with a complete assortment of CMT Ogee bits. All CMT bits feature micrograin carbide edges, high-strength European steel and our trademark orange coating.

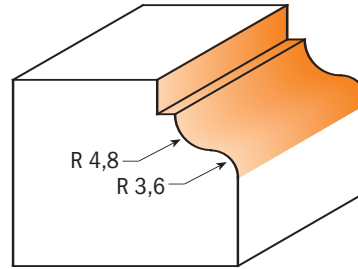
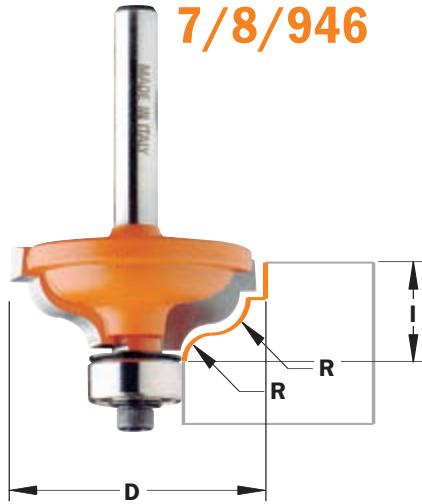

Drawings are 1:1 scale

R Radius		D Cutting diameter	I Cutting length	ORDER NO. Shank Ø 6mm	ORDER NO. Shank Ø 6,35mm	ORDER NO. Shank Ø 8mm	ORDER NO. Shank Ø 12mm	ORDER NO. Shank Ø 12,7mm
mm	inches	mm	mm					
4,8 - 3,6	3/16-9/64	34,2	13	<b>746.325.11</b>	<b>846.325.11</b>	<b>946.325.11</b>	<b>946.825.11</b>	<b>846.825.11</b>
<b>Spare parts:</b>		<b>990.423.00</b> Ø12,7mm shield	<b>791.003.00</b> Ø12,7mm bearing		<b>990.058.00</b> 1/8W screw		<b>991.057.00</b> 3/32" hex key	

Ogee with fillet bits

7/8/947



For a more-detailed version of the beautiful profile above, this bit adds an inset bead along the lower edge of the cut.

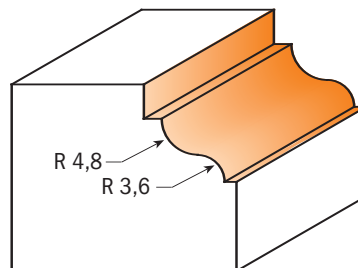
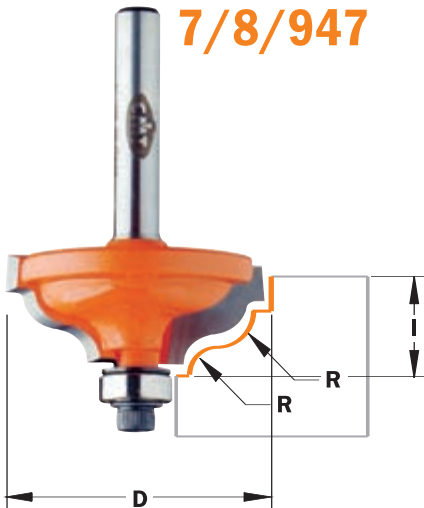

Drawings are 1:1 scale

R Radius		D Cutting diameter	I Cutting length	ORDER NO. Shank Ø 6mm	ORDER NO. Shank Ø 6,35mm	ORDER NO. Shank Ø 8mm	ORDER NO. Shank Ø 12mm	ORDER NO. Shank Ø 12,7mm
mm	inches	mm	mm					
4,8 - 3,6	3/16-9/64	34,2	13	<b>747.325.11</b>	<b>847.325.11</b>	<b>947.325.11</b>	<b>947.825.11</b>	<b>847.825.11</b>
<b>Spare parts:</b>		<b>990.422.00</b> Ø9,5mm shield	<b>791.002.00</b> Ø9,5mm bearing		<b>990.058.00</b> 1/8W screw		<b>991.057.00</b> 3/32" hex key	

7/8/959



These profiles are the mirror image of the traditional roman ogee. They add a sharp defining detail to the edges of cabinets and furniture before rolling into a smooth convex shape.

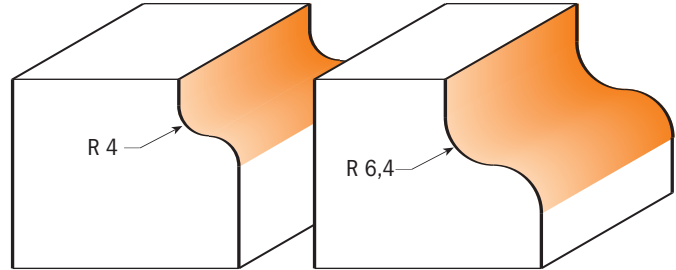
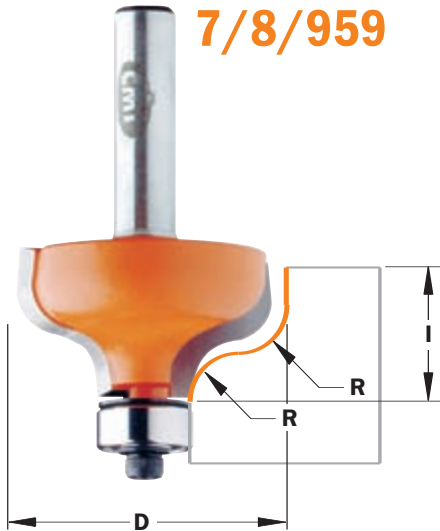

Drawings are 1:1 scale

R Radius		D Cutting diameter	I Cutting length	ORDER NO. Shank Ø 6mm	ORDER NO. Shank Ø 6,35mm	ORDER NO. Shank Ø 8mm	ORDER NO. Shank Ø 12mm	ORDER NO. Shank Ø 12,7mm
mm	inches	mm	mm					
4	5/32	28,7	13	<b>759.040.11</b>	<b>859.040.11</b>	<b>959.040.11</b>	<b>959.540.11</b>	<b>859.540.11</b>
6,4	1/4	38,1	18	<b>759.064.11</b>	<b>859.064.11</b>	<b>959.064.11</b>	<b>959.564.11</b>	<b>859.564.11</b>

Spare parts: 990.423.00 Ø12,7mm shield      791.003.00 Ø12,7mm bearing      990.058.00 1/8W screw      991.057.00 3/32" hex key

7/8/960



These tools are identical to the 859 series above, with the addition of an inset bead along the lower edge.

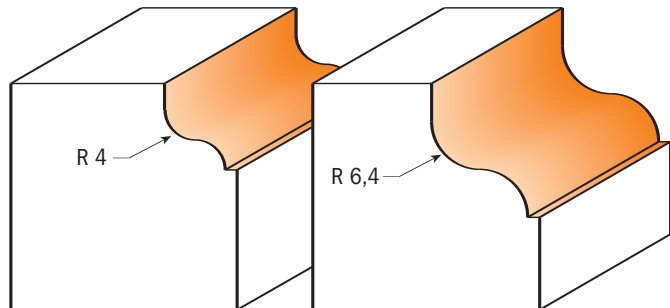
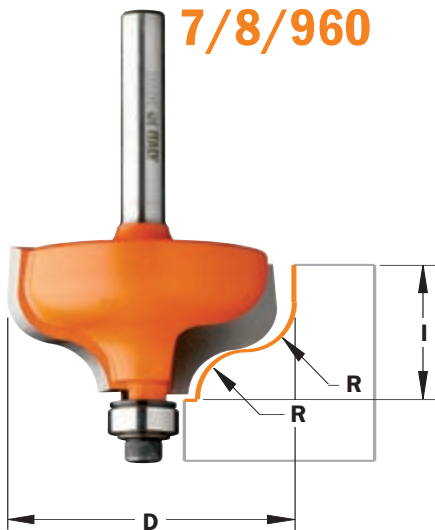

Drawings are 1:1 scale

R Radius		D Cutting diameter	I Cutting length	ORDER NO. Shank Ø 6mm	ORDER NO. Shank Ø 6,35mm	ORDER NO. Shank Ø 8mm	ORDER NO. Shank Ø 12mm	ORDER NO. Shank Ø 12,7mm
mm	inches	mm	mm					
4	5/32	28,7	13	<b>760.040.11</b>	<b>860.040.11</b>	<b>960.040.11</b>	<b>960.540.11</b>	<b>860.540.11</b>
6,4	1/4	38,1	18	<b>760.064.11</b>	<b>860.064.11</b>	<b>960.064.11</b>	<b>960.564.11</b>	<b>860.564.11</b>

Spare parts: 990.422.00 Ø9,5mm shield      791.002.00 Ø9,5mm bearing      990.058.00 1/8W screw      991.057.00 3/32" hex key





**8/967.5B**



CMT's new Molding bits designed by Lonnie Bird allows you to shape elegant moldings with your tablesaw and router table. Unlike commercially available crown molding, molding made with these bits are easy to install and creates a finished appearance. After shaping the cove, you can use the special router bits with inverted profiles to create various edge treatments and complete the molding.

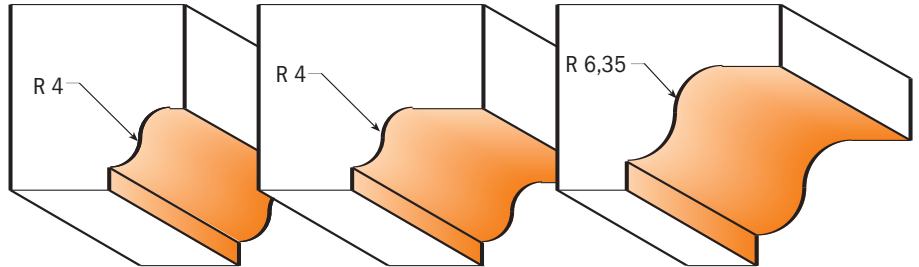

Drawings are 1:1 scale

R Radius		D Cutting diameter mm	I Cutting length mm	ORDER NO. Shank Ø 8mm	ORDER NO. Shank Ø 12mm	ORDER NO. Shank Ø 12,7mm
mm	inches					
4	5/32	39,5	11,5	<b>967.001.11B</b>	<b>967.501.11B</b>	<b>867.501.11B</b>
4	5/32	54	11,5		<b>967.502.11B</b>	<b>867.502.11B</b>
6,35	1/4	60,5	17,3		<b>967.503.11B</b>	<b>867.503.11B</b>

Spare parts: **791.011.00** Ø19mm bearing

**541.002.00** Stop collar for Ø12,7mm shanks

**991.056.00** 1,5mm hex key

# Molding bits "Lonnie Bird"

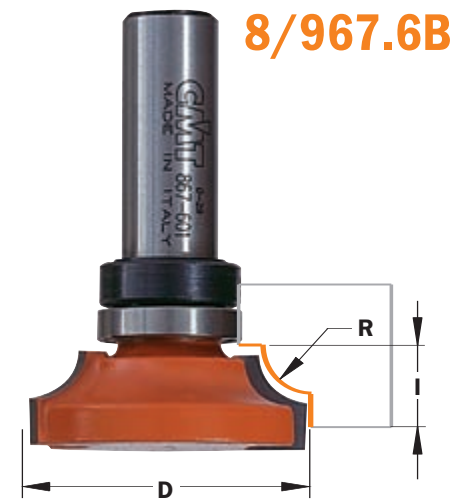

**8/967.6B**



CMT's new Molding bits designed by Lonnie Bird allows you to shape elegant moldings with your tablesaw and router table. Unlike commercially available crown molding, molding made with these bits are easy to install and creates a finished appearance. After shaping the cove, you can use the special router bits with inverted profiles to create various edge treatments and complete the molding.

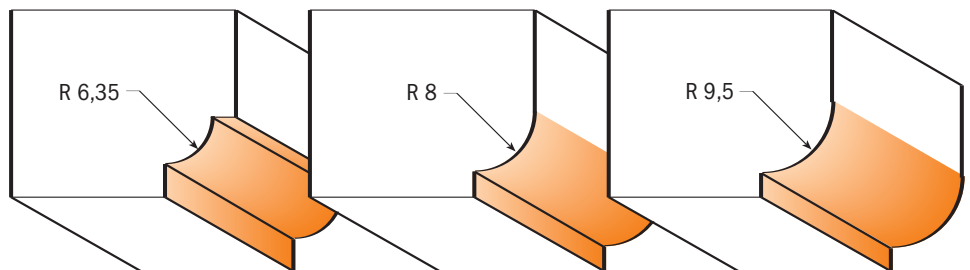

Drawings are 1:1 scale

R Radius		D Cutting diameter mm	I Cutting length mm	ORDER NO. Shank Ø 8mm	ORDER NO. Shank Ø 12mm	ORDER NO. Shank Ø 12,7mm
mm	inches					
6,35	5/32	38	12,5	<b>967.101.11B</b>	<b>967.601.11B</b>	<b>867.601.11B</b>
8	5/16	35	13,2	<b>967.102.11B</b>	<b>967.602.11B</b>	<b>867.602.11B</b>
9,5	3/8	38	14,5	<b>967.103.11B</b>	<b>967.603.11B</b>	<b>867.603.11B</b>

Spare parts: **791.011.00** Ø19mm bearing

**541.002.00** Stop collar for Ø12,7mm shanks

**991.056.00** 1,5mm hex key

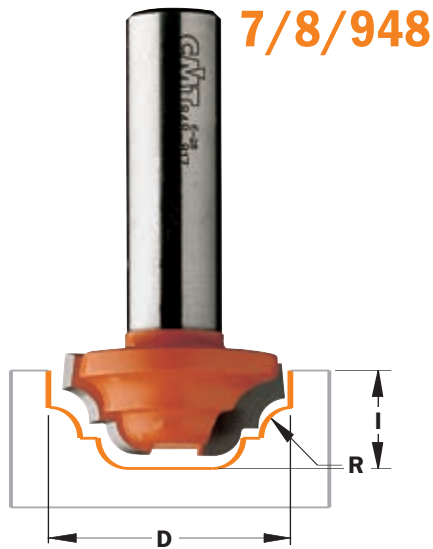

You will never run out of ideas with this creative bit. Add a classic touch to any edge or highlight door fronts and panels with decorative layered effects. For even more options, try the CMT plunge ogee with bearing guide for pattern following.

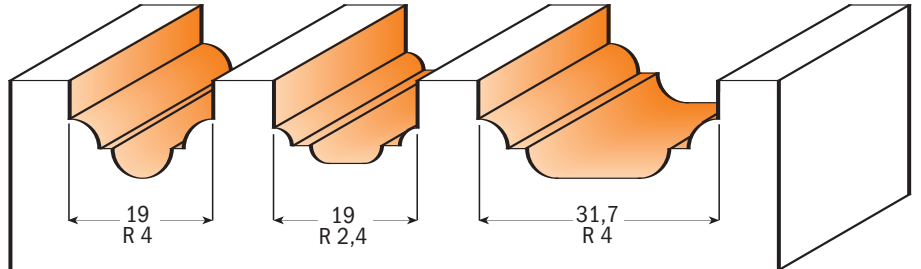

Drawings are 1:1 scale

D Cutting diameter mm inches	R Radius mm	I Cutting length mm	ORDER NO. Shank Ø 6mm	ORDER NO. Shank Ø 6,35mm	ORDER NO. Shank Ø 8mm	ORDER NO. Shank Ø 12mm	ORDER NO. Shank Ø 12,7mm
19 3/4	4	13	<b>748.190.11</b>	<b>848.190.11</b>	<b>948.190.11</b>		
19 3/4	2,4	12	<b>748.191.11</b>	<b>848.191.11</b>	<b>948.191.11</b>		
31,7 1-1/4	4	13			<b>948.317.11</b>	<b>948.817.11</b>	<b>848.817.11</b>

**Plunge ogee bits**

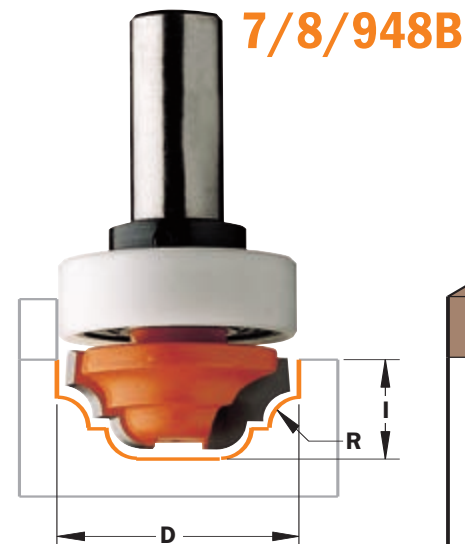

For even more ogee profile options from CMT, there is the plunge ogee equipped with a double-protection ball bearing attached to the shank. Excellent for achieving accurate decorative work and guaranteed to give a longer lasting performance.

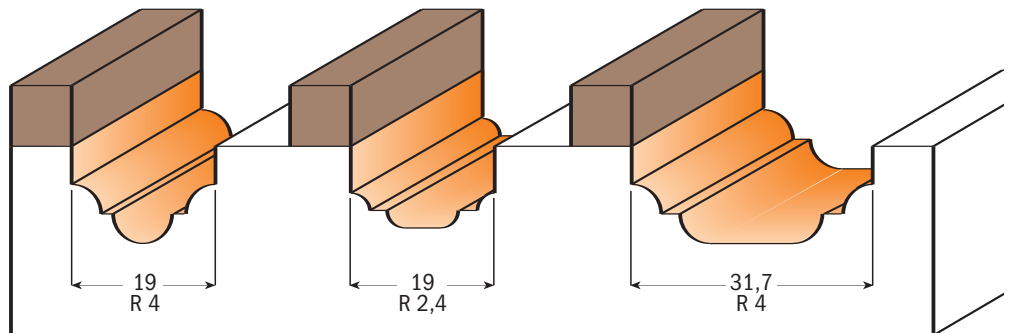

Drawings are 1:1 scale

D Cutting diameter mm inches	R Radius mm	I Cutting length mm	ORDER NO. Shank Ø 6mm	ORDER NO. Shank Ø 6,35mm	ORDER NO. Shank Ø 8mm	ORDER NO. Shank Ø 12mm	ORDER NO. Shank Ø 12,7mm
19 3/4	4	13	<b>748.190.11B</b>	<b>848.190.11B</b>			
19 3/4	2,4	12	<b>748.191.11B</b>	<b>848.191.11B</b>			
31,7 1-1/4	4	13			<b>948.317.11B</b>	<b>948.817.11B</b>	<b>848.817.11B</b>

**Spare parts:** **791.007.00** Ø19mm bearing with Ø6mm bore  
**791.004.00** Ø19mm bearing with Ø6,35mm bore  
**791.015.00** Ø31,7mm bearing

**541.003.00** Stop collar for Ø6mm shanks  
**541.001.00** Stop collar for Ø6,35mm shanks  
**541.005.00** Stop collar for Ø12mm shanks

**541.002.00** Stop collar for Ø12,7mm shanks  
**991.056.00** 1,5mm hex key

**7/8/965.001**



This new CMT ogee bit makes a subtle decorative edge, perfect for enhancing doors and drawer fronts. Carbide-tipped to ensure a clean, sharp cut. This new CMT bead bit produces a classic single or double edged bead. Ideal for creating a marked decorative effect on panel, door and drawer work.

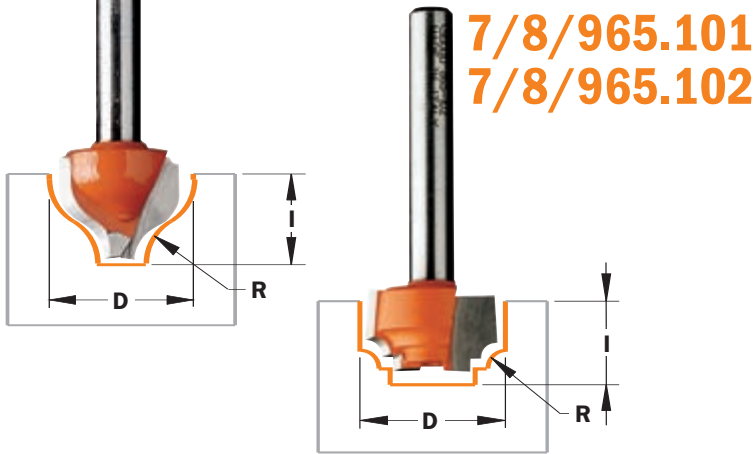

**7/965.402**

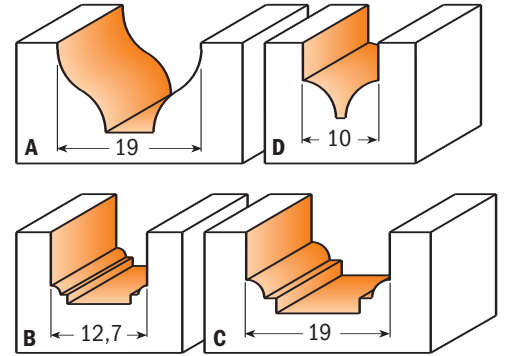

Drawings are 1:1 scale

D Cutting diameter mm	R Radius mm	I Cutting length mm	Profile	ORDER NO. Shank Ø 6mm	ORDER NO. Shank Ø 6,35mm	ORDER NO. Shank Ø 8mm	ORDER NO. Shank Ø 12mm	ORDER NO. Shank Ø 12,7mm
19	6,4	11	A	765.001.11	865.001.11	965.001.11	965.501.11	865.501.11
12,7	1,2	12,7	B	765.101.11	865.101.11	965.101.11		
19	2,4	11	C	765.102.11	865.102.11	965.102.11		
10	5	10	D	765.402.11	865.402.11	965.402.11		

Classical bead bits

**7/865.201B**  
**965.202B**



This new CMT classic panel ogee with ball bearing guide gives you even more decorative possibilities for panel and edge work. The bit design gives you a wide flat bottom cut and the longer shank allows for deeper detailing.

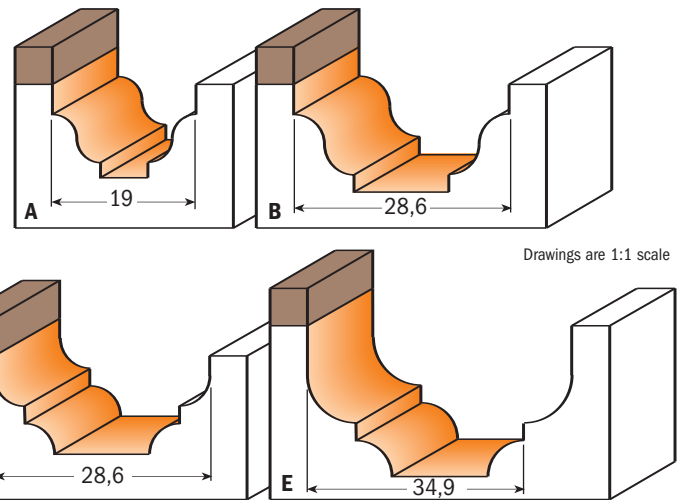
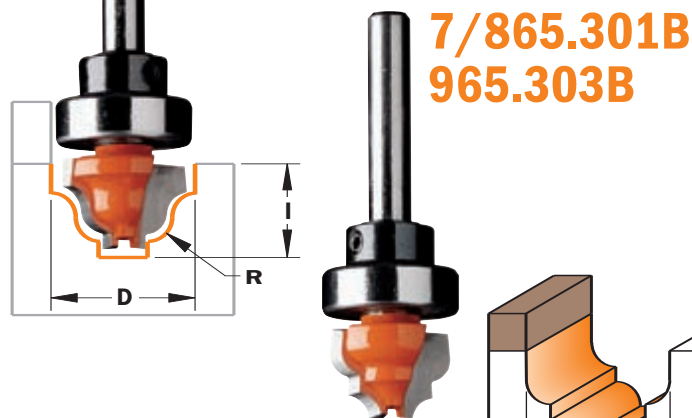

Drawings are 1:1 scale

D Cutting diameter mm	R Radius mm	I Cutting length mm	Profile	ORDER NO. Shank Ø 6mm	ORDER NO. Shank Ø 6,35mm	ORDER NO. Shank Ø 8mm	ORDER NO. Shank Ø 12mm	ORDER NO. Shank Ø 12,7mm
19	3,2	12,3	A	765.201.11B	865.201.11B			
28,6	4	14,3	B			965.202.11B	965.702.11B	865.702.11B
19	3,2	12,3	C	765.301.11B	865.301.11B			
28,6	4	13,3	D			965.302.11B	965.802.11B	865.802.11B
34,9	4,76 - 6,35	18,5	E			965.303.11B		865.803.11B

**Spare parts:** 791.007.00 Ø19mm bearing with Ø6mm bore  
791.004.00 Ø19mm bearing with Ø6,35mm bore  
791.027.00 Ø28,6mm bearing

791.031.00 Ø34,9mm bearing  
541.003.00 Stop collar for Ø6mm shanks  
541.001.00 Stop collar for Ø6,35mm shanks

541.005.00 Stop collar for Ø12mm shanks  
541.002.00 Stop collar for Ø12,7mm shanks  
991.056.00 1,5mm hex key

Why waste time searching for a particular style of frame molding when you can just as quickly and easily make your own. With the wide range of decorative possibilities offered by CMT molding bits, you can always create the edge profile you want, anywhere you want and any time you want. These CMT bits are made to last a lifetime - carbide-tipped cutters and solid bar stock steel shanks can withstand serious use and the baked-on non-stick PTFE coating makes sure you continuously get clean, smooth-running cuts. Our anti-kickback feature helps guarantee you work more safely when using these wide profile bits.



8/955.902

**Shop Tips:** Multiple pass operations require advance planning. To avoid making a mistake that could render it impossible to finish the job, carefully consider the entire cutting sequence before you begin.

**Safety Tips:** All large diameter bits such as these should be used with caution and on router tables equipped with a fence. For best results, 2-1/4 HP routers are recommended. Routers as low-powered as 1-1/2 HP can be used if limited to shorter, shallower runs. When possible, reduce the RPMs of the router for operations requiring the use of these bits.

8/955.901

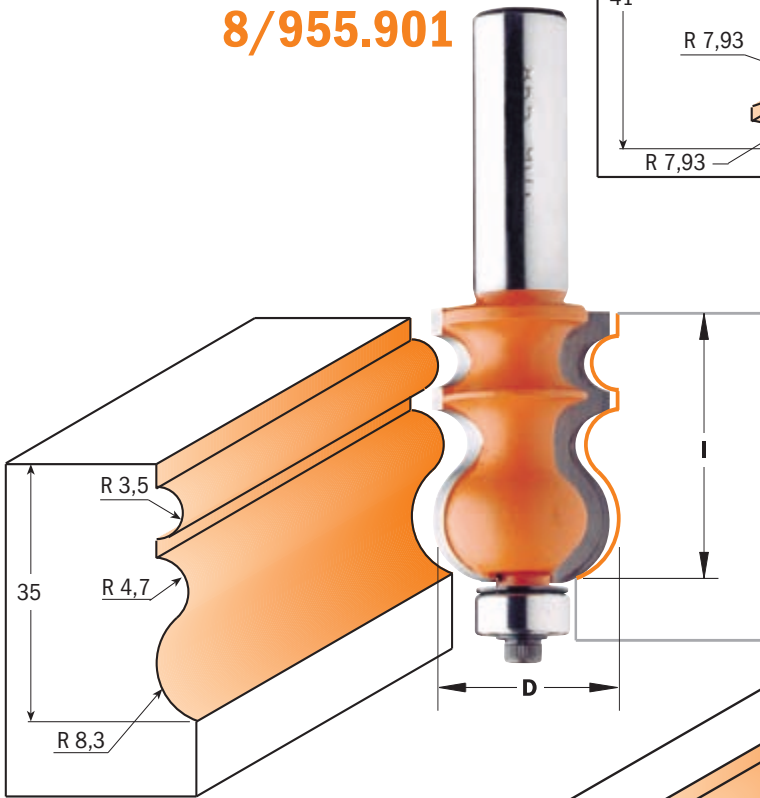
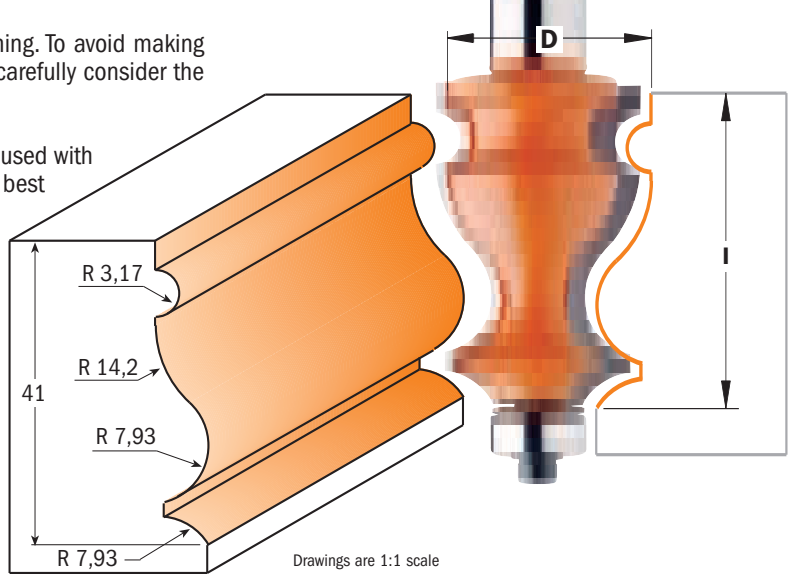

8/956.501

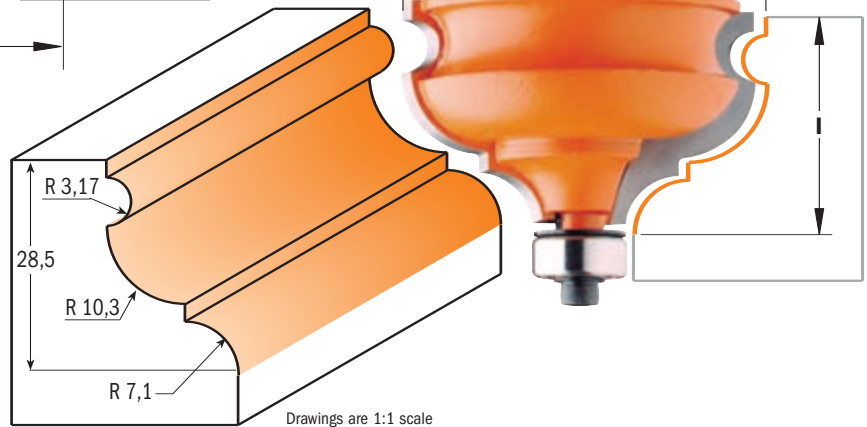

D Cutting diameter		I Cutting length	ORDER NO. Shank Ø 12mm	ORDER NO. Shank Ø 12,7mm
mm	inches	mm		
23,8	15/16	35	955.901.11	855.901.11
27	1-1/16	41	955.902.11	855.902.11
47,5	1-7/8	28,5	956.501.11	856.501.11

Spare parts: 990.423.00 Ø12,7mm shield

791.003.00 Ø12,7mm bearing

990.058.00 1/8W screw

991.057.00 3/32" hex key



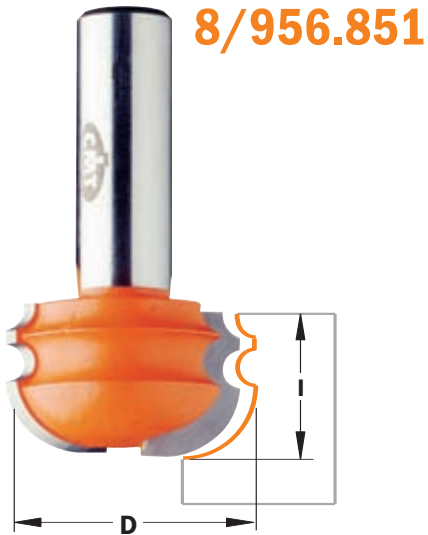

If the standard selection of molding and mill work you find in today's lumber shops isn't satisfactory to your woodworking tastes, then look to CMT's molding system instead. With these bits, you can make dozens of elaborate profiles by combining two or more passes. Avoid the average and create your own moldings. Some initial suggestions are illustrated below.

**Safety tips:** Use these bits with a fence. The profiles shown below are milled from heavy stock then refined to the desired shape.

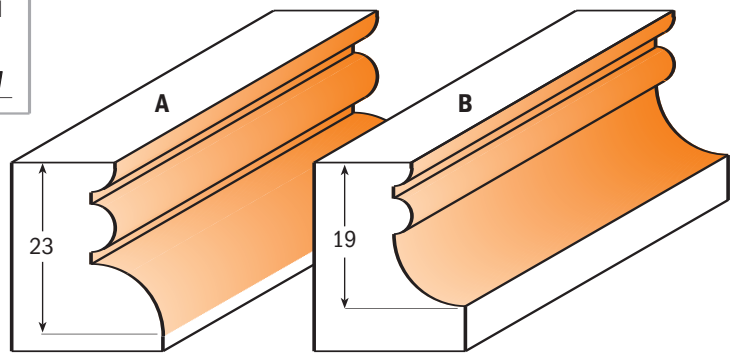
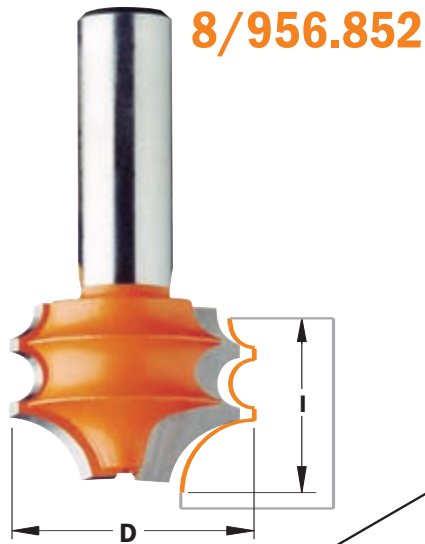

Drawings are 1:1 scale

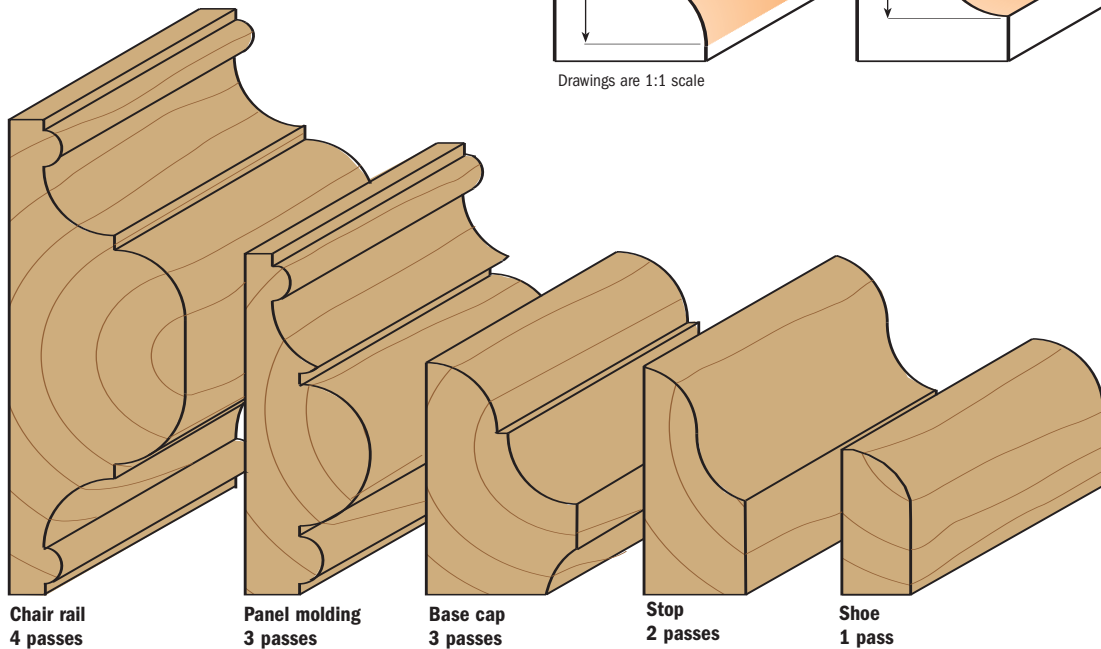

Profile	D Cutting diameter		I Cutting length mm	ORDER NO. Shank Ø 12mm	ORDER NO. Shank Ø 12,7mm
	mm	inches			
A	31,7	1-1/4	23	<b>956.852.11</b>	<b>856.852.11</b>
B	31,7	1-1/4	19	<b>956.851.11</b>	<b>856.851.11</b>

**8/956.8**



There is no limit to the profiles you can create with CMT multiprofile bits. Simply adjust the height of the bit to create classic profiles in a single pass. Or make several passes to create more complex and decorative effects. The super-strength steel body of the CMT multiprofile stands up to hours of cutting and micrograin carbide tips stay sharp longer for a guaranteed superior performance. Features baked-on non-stick PTFE coating and anti-kickback design. Use on tables equipped with a fence.

**Safety tips:** To make small molding as shown below, cut the profile from very wide stock. Remove the excess material and work on the bigger piece to give you easier control. Keep hands far from the bit when working.

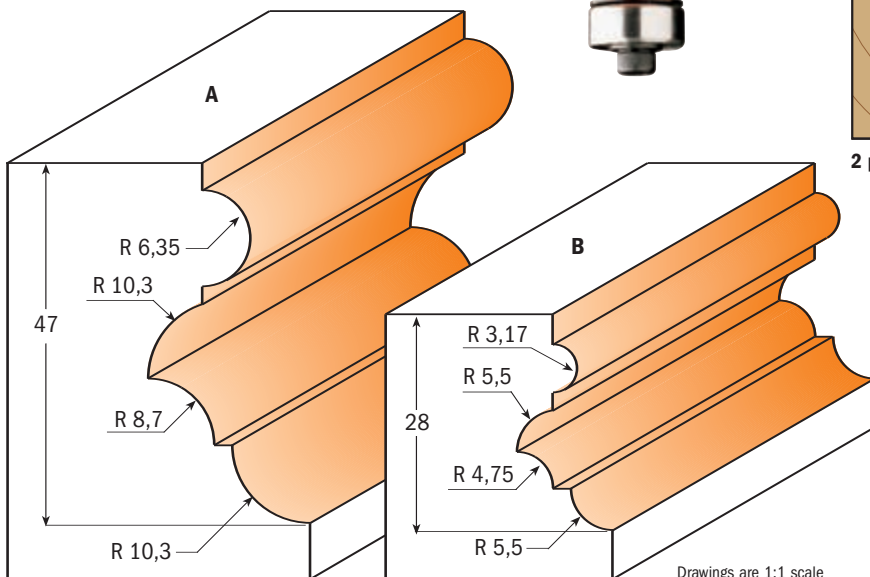
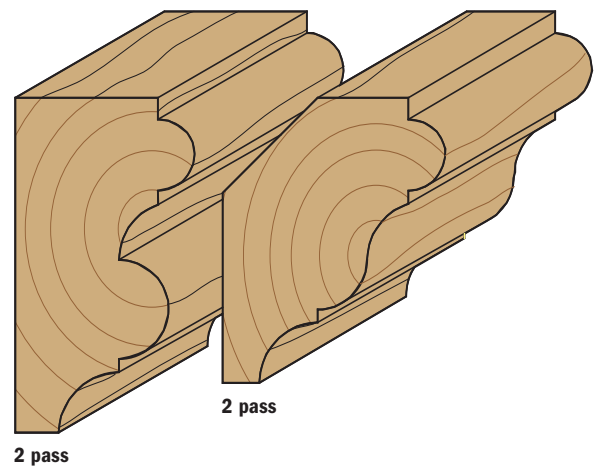
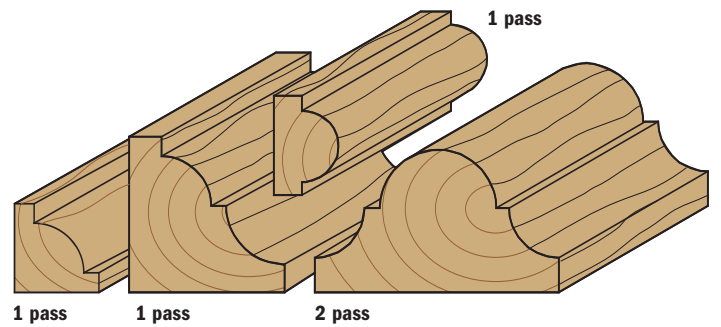

Drawings are 1:1 scale

Profile	D Cutting diameter		I Cutting length			ORDER NO. Shank Ø 12mm	ORDER NO. Shank Ø 12,7mm
A	55,6	2-3/16	47			<b>956.802.11</b>	<b>856.802.11</b>
B	38,1	1-1/2	28			<b>956.801.11</b>	<b>856.801.11</b>

**Spare parts:** 990.423.00 Ø12,7mm shield      791.003.00 Ø12,7mm bearing      990.058.00 1/8W screw      991.057.00 3/32" hex key



8/956.701



Your investment will be well repaid with the variety of decorative profiles you can achieve with these CMT bits. Our table edge bits give perfectly smooth well-proportioned curves to dining and coffee table edges. CMT hand rail bits with a 30° bevel edge and a 3,2mm bead allow you to make beautiful and functional hand rails that add an understated touch of class to any architectural setting.

**Safety tips:** These wide profile bits remove large amounts of material when cutting and create a great quantity of saw dust. We suggest using a vacuum on your router table to make the job easier and keep the work area safe.

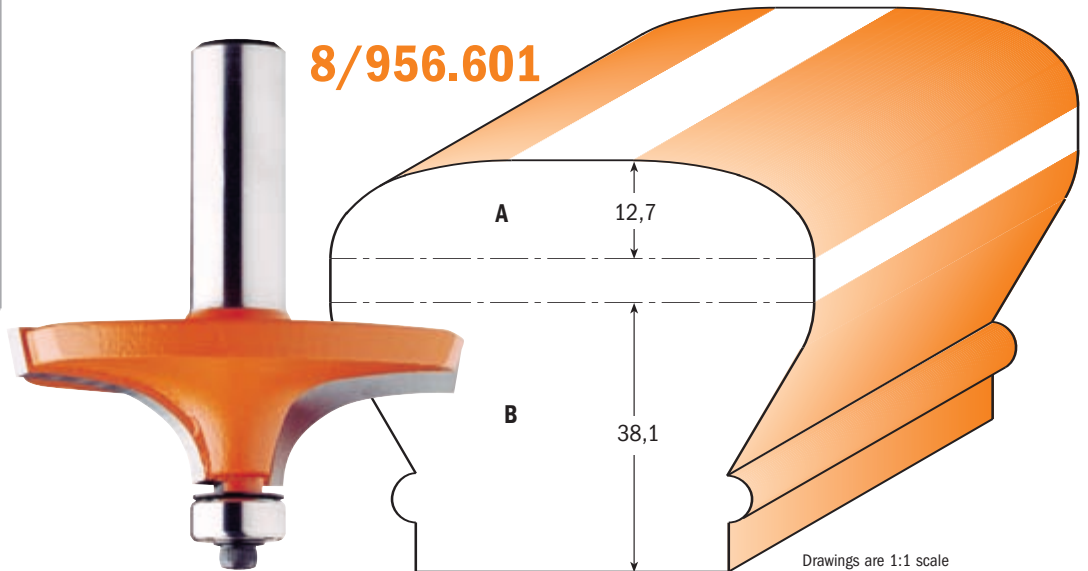

8/956.601

Drawings are 1:1 scale

Profile	D Cutting diameter		I Cutting length	ORDER NO.	ORDER NO.
	mm	inches			
A	63,5	2-1/2	19	956.601.11	856.601.11
B	35	1-3/8	38	956.701.11	856.701.11

Spare parts: 990.423.00 Ø12,7mm shield      791.003.00 Ø12,7mm bearing      990.058.00 1/8W screw      991.057.00 3/32" hex key

Flute & bead set



8/955.701



This perfectly mated CMT set is the ideal way to make canoe slats and hot tubs. Durable carbide facing stays sharp even after cutting great quantities of stock and the anti-kickback design feature ensures your safety when working.

For fluting and beading 6,35mm slats for a curved glue-up as shown below, use both the flute and the bead bits in the set.

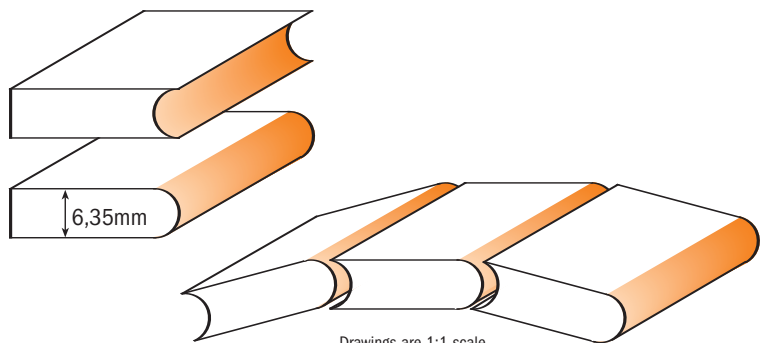

Drawings are 1:1 scale

R Radius	D Cutting diameter		ORDER NO.	ORDER NO.
	mm	inches		
3,2	1/8	38	955.701.11	855.701.11

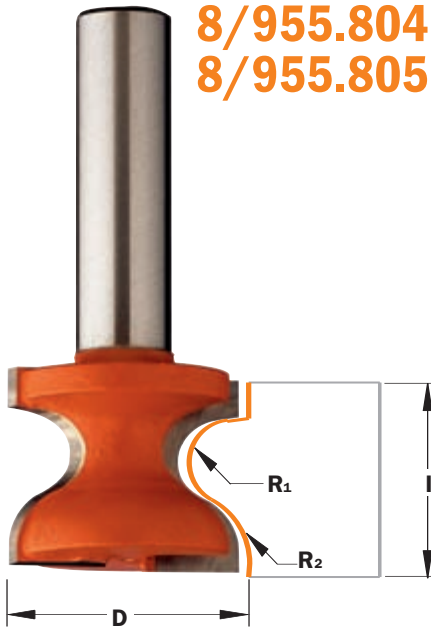

These profiles were originally intended for shaping the edges of window sills. Now these bits are also used for creating finger pulls on the edges of doors and drawers. This profile is available in a small and large version for 15,8mm to 19mm or 25,4mm to 28,7 mm material thicknesses. Recommended for router table use only.

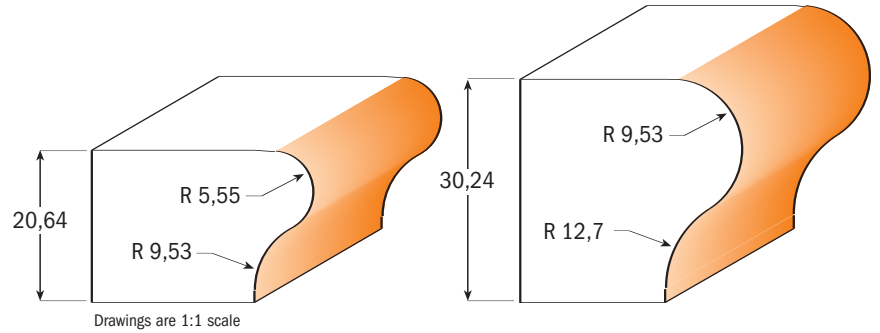

R <sub>1</sub> Radius		R <sub>2</sub> Radius		D Cutting diameter	I Cutting length	ORDER NO. Shank Ø 12mm	ORDER NO. Shank Ø 12,7mm
mm	inches	mm	inches				
5,5	7/32	9,5	3/8	31,7	25,4	<b>955.804.11</b>	<b>855.804.11</b>
9,5	3/8	12,7	1/2	38,1	35	<b>955.805.11</b>	<b>855.805.11</b>

**Window sill and finger pull bits**

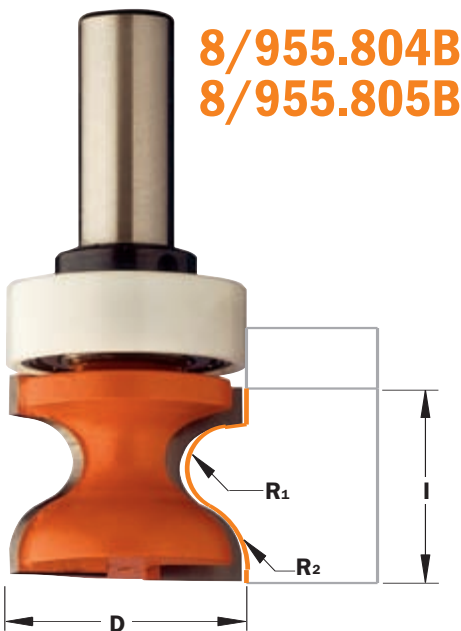

These profiles were originally intended for shaping the edges of window sills. Now these bits are also used for creating finger pulls on the edges of doors and drawers. This profile is available in a small and large version for 15,8mm to 19mm or 25,4mm to 28,7mm material thicknesses. These bits are available with top bearings for curved template work or without bearings for straight cuts against a fence. Recommended for router table use only.

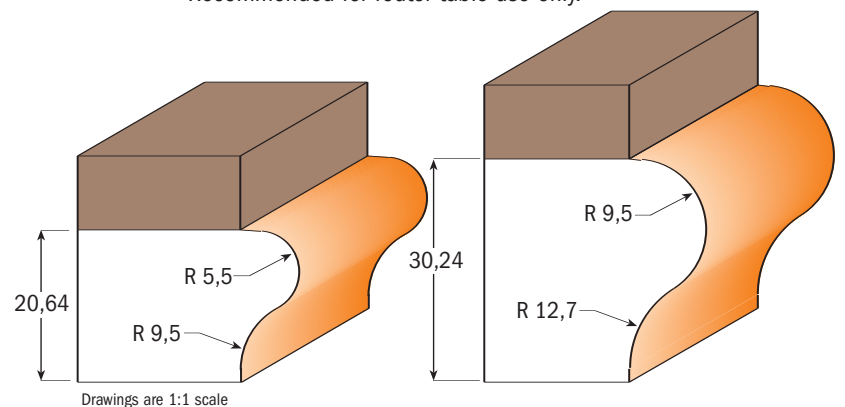

R <sub>1</sub> Radius		R <sub>2</sub> Radius		D Cutting diameter	I Cutting length	ORDER NO. Shank Ø 12mm	ORDER NO. Shank Ø 12,7mm
mm	inches	mm	inches				
5,5	7/32	9,5	3/8	31,7	25,4	<b>955.804.11B</b>	<b>855.804.11B</b>
9,5	3/8	12,7	1/2	38,1	35	<b>955.805.11B</b>	<b>855.805.11B</b>

**Spare parts:** 791.015.00 Ø31,7mm bearing  
541.002.00 Stop collar for Ø12,7mm shanks

791.020.00 Ø38,1mm bearing  
991.056.00 1,5mm hex key

541.005.00 Stop collar for Ø12mm shanks



8/955.501



The most unique and important characteristic of this CMT bit is its capacity to produce an almost indestructible glue joint quickly and without error. Ideal for routing wide dimension panels, doors and furniture pieces. By accurately centering the bit to the wood, the upper and lower vertical cutting edges of the bit will cut equal proportions. Simply run one edge of the panel, turn the panel over, and then run the opposite edge - you will produce perfectly harmonized reverse cuts that match up to make flawless joints.

**Shop tips:** When glueing, apply enough pressure to securely seal the joint. Insufficient pressure results in a weak joint and excessive pressure will distort the wood.

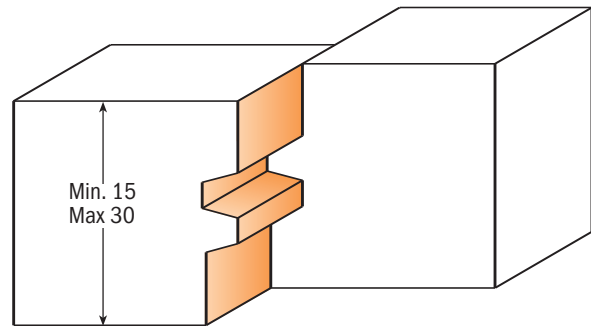

Drawings are 1:1 scale

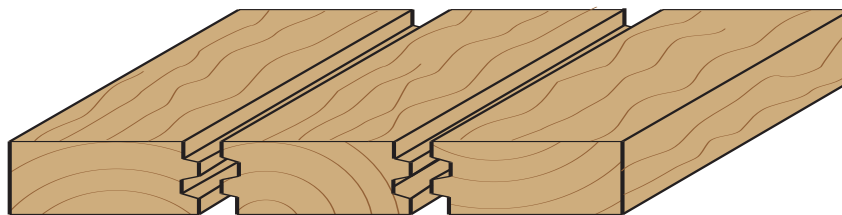

In this example we have used a 19mm board

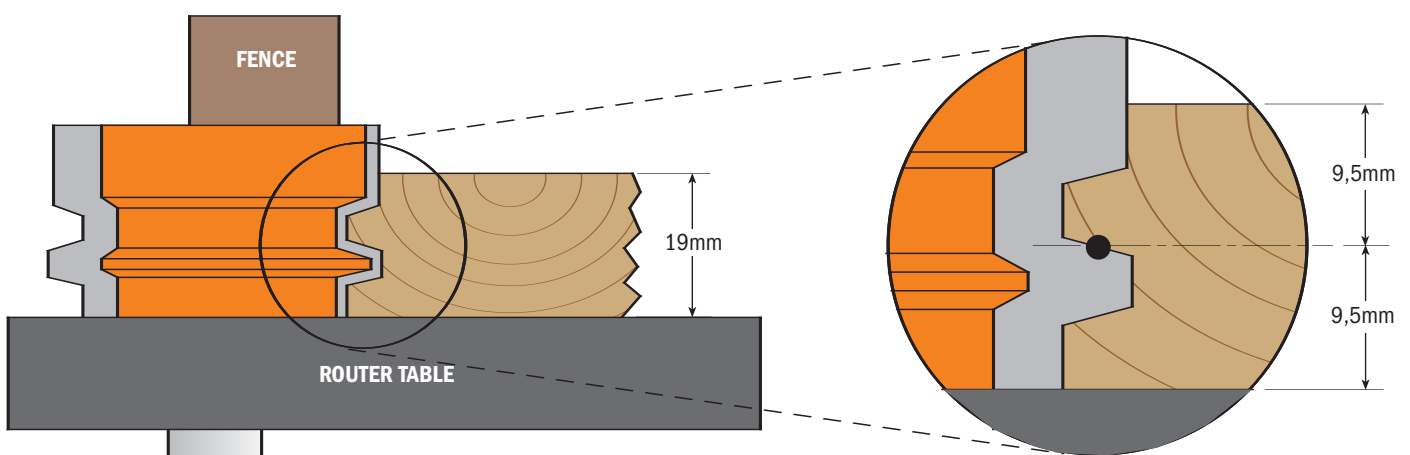

To accurately centre the wood to the bit: Adjust the bit according to the thickness of the wood you are cutting. Line up the cut edge of the wood to the centre point of the bit as illustrated in the enlarged drawing. The upper and lower vertical cutting edges of the bit are in proportion and at an equal distance from the centre point of the bit. Run one cut edge of the wood, turn the piece over and run the other edge for exact reverse cuts that match up perfectly. Assemble the reverse cut pairs together for beautiful, strong joints.

D Cutting diameter		I Cutting length	ORDER NO. Shank	ORDER NO. Shank
mm	inches	mm	Ø 12mm	Ø 12,7mm
44,4	1-3/4	32	955.501.11	855.501.11

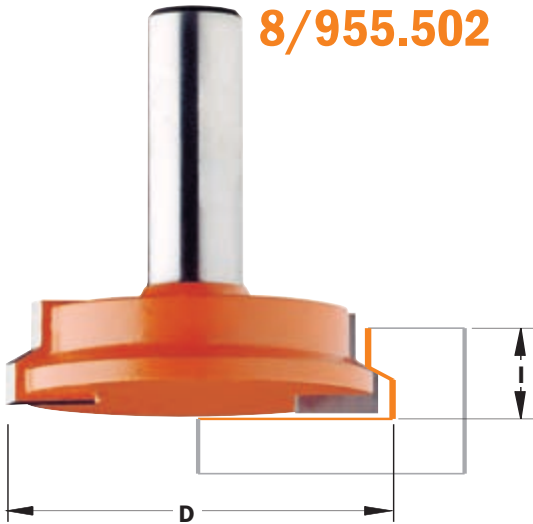

The key to success when constructing quality drawers is in the quality of the drawer lock bit you use. With CMT drawer lock bits you can make strong, perfectly fitting joints quickly and easily. As illustrated below, mill the drawer front with the inside face-down on the work table. Mill the sides of the drawer with the inside face placed vertical to the bit and fence, and perpendicular to the table. These bits are to be used on router tables only and are not to be used on hand-held routers.

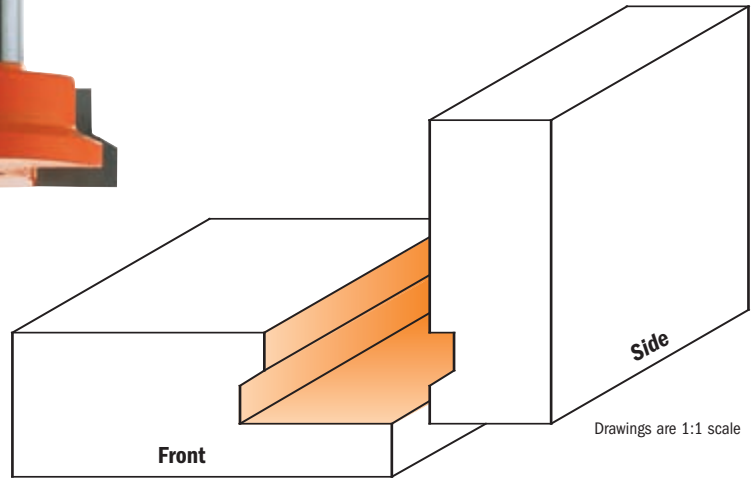

Drawings are 1:1 scale

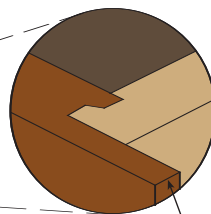
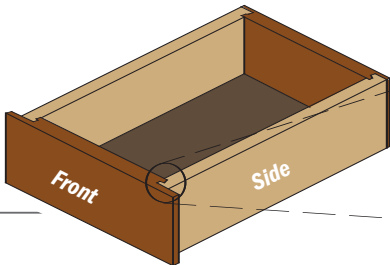

Overhang for drawer stop

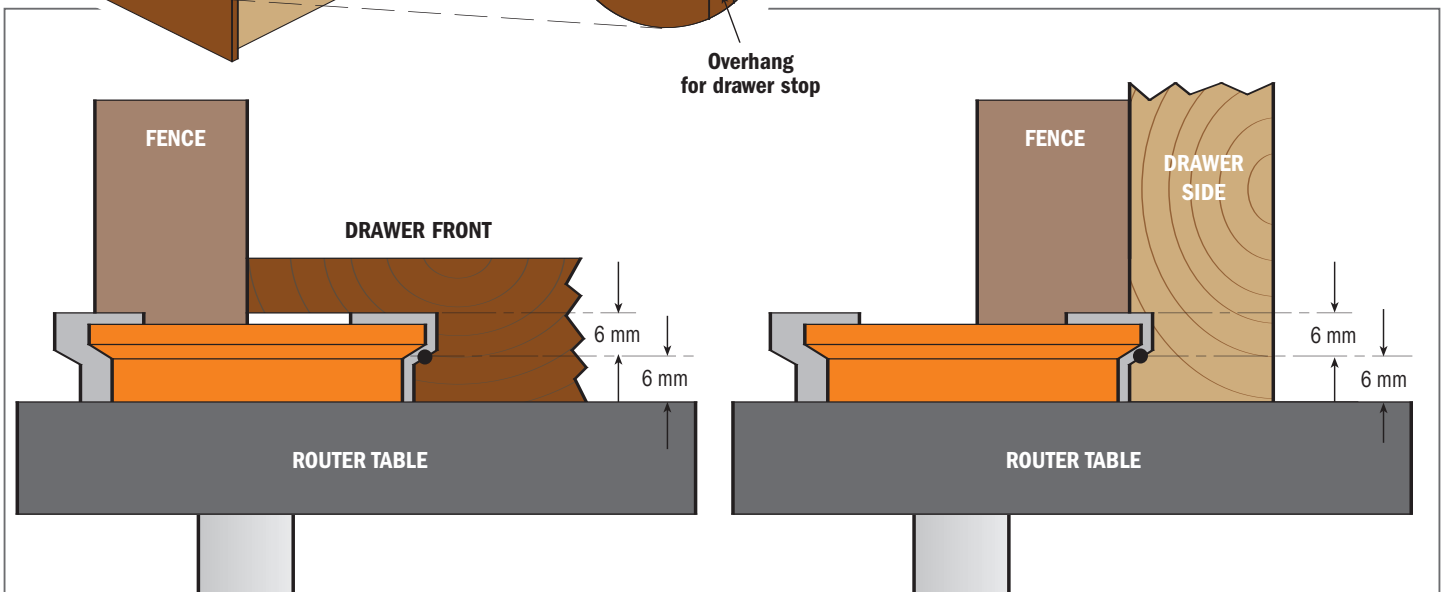

D	I	ORDER NO.	ORDER NO.	ORDER NO.	ORDER NO.	ORDER NO.
Cutting diameter	Cutting length	Shank	Shank	Shank	Shank	Shank
mm	mm	Ø 6mm	Ø 6,35mm	Ø 8mm	Ø 12mm	Ø 12,7mm
31,7	12,7	755.002.11	855.002.11	955.002.11		
50,8	12,7				955.502.11	855.502.11



8/955.503



CMT lock miter bits are ideal for milling miter joints in 28,5mm stock. The quick and easy way to accurately create boxes, stretcher bars, frames and any assortment of right angle or parallel joint projects.

To produce perfectly fitting miter joints, lay one piece with the inside face-down on the work table and the wood centred to the bit. Mill as shown in step 1 of the illustration below. Mill the second piece with the inside face placed vertical to the bit and fence, as shown in step 2.

To mill sturdy parallel glue joints follow step 1 shown in the illustration with the inside face of the workpiece laid flat on the table and centred to the bit. To make the second part, lay the workpiece flat on the table and centred to the bit. Mill with the inside face-up.

8/955.504

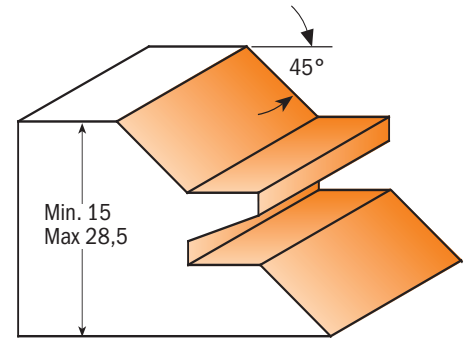
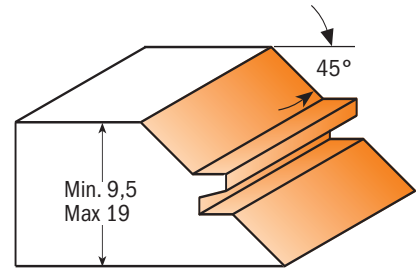
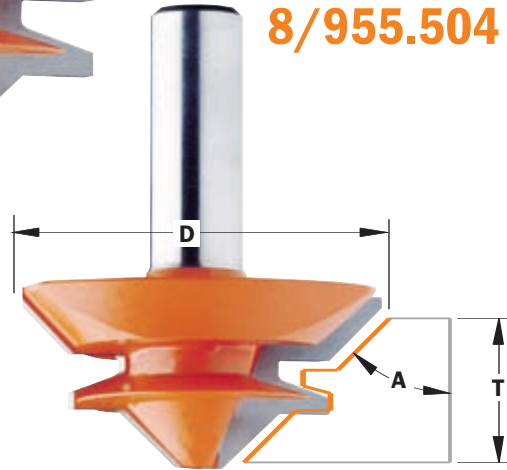

Drawings are 1:1 scale

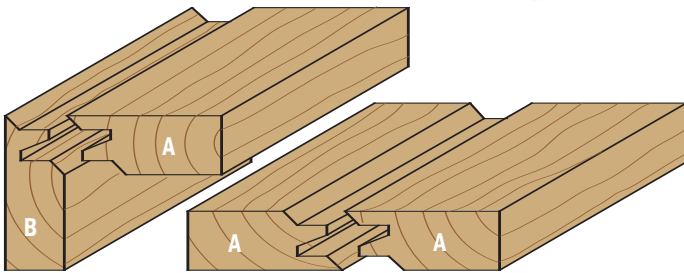

For miter and parallel glue joints using 19mm board

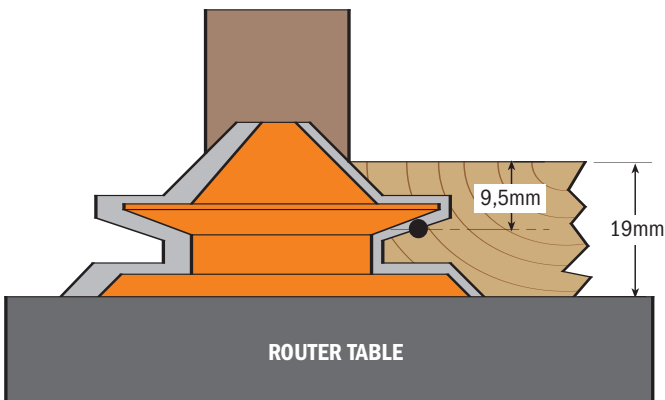

**Nr. 1:** Rout one piece with the inside face flat on the router table. Be sure the cut is centred to the stock.

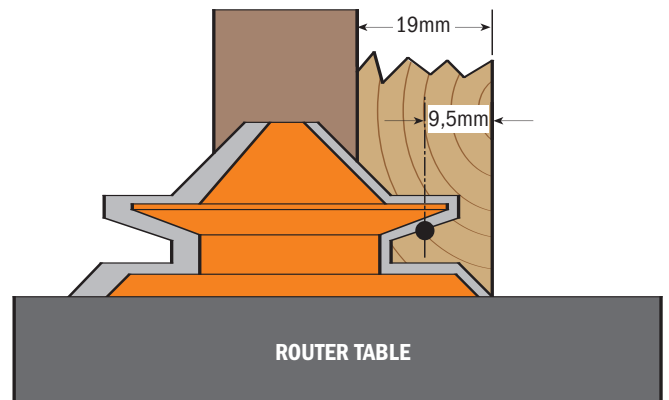

**Nr. 2:** Rout the second piece with the inside face vertical to the fence.

D	I	A	T	ORDER NO.	ORDER NO.
Cutting diameter	Cutting length	Cutting angle	Maximum joint thickness	Shank	Shank
mm	mm		mm	Ø 12mm	Ø 12,7mm
70	31,7	45°	15 ÷ 28,5	955.503.11	855.503.11
50,8	22,2	45°	9,5 ÷ 19	955.504.11	855.504.11



Now you don't have to fight with those awkward clamps on your 22,5° projects. Use this pair of bits to produce octagonal shaped boxes and popular corner cabinetry like corner cabinets for kitchens, entertainment centres, kitchen islands and corner hutches. This 22,5° Lock Miter set provides a strong tight joint when you want to join wood at 45° angles.

Biscuits and splines are time-consuming to make and difficult to clamp. CMT's matched pair of cutters makes set-up easy. Height adjustment is not critical with this matched pair; simply adjust your fence so the top edge of the work piece intersects the angle of the bit where it meets the fence.

After your joints are machined they can be glued and assembled and simply clamped by using strapping tape.

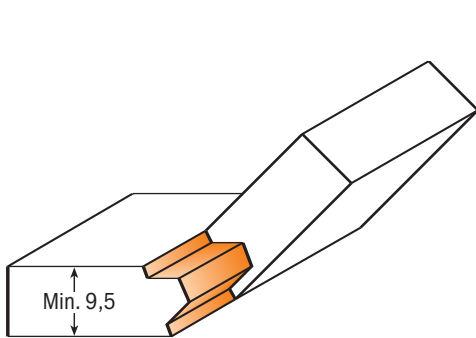
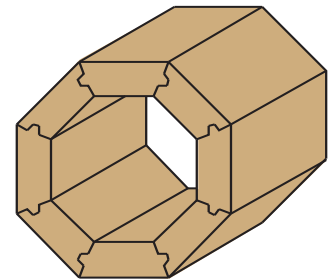
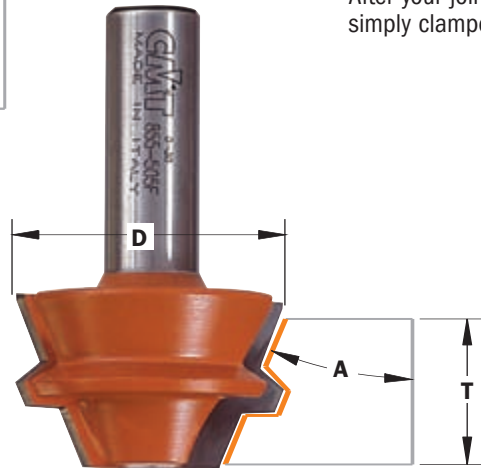

Drawings are 1:1 scale

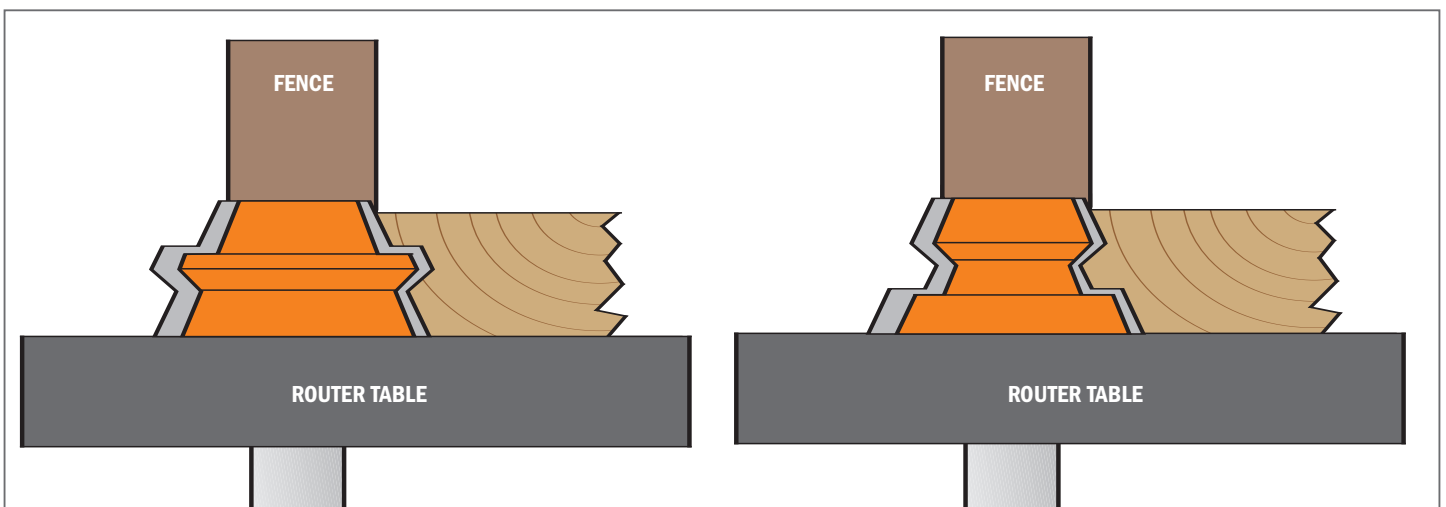
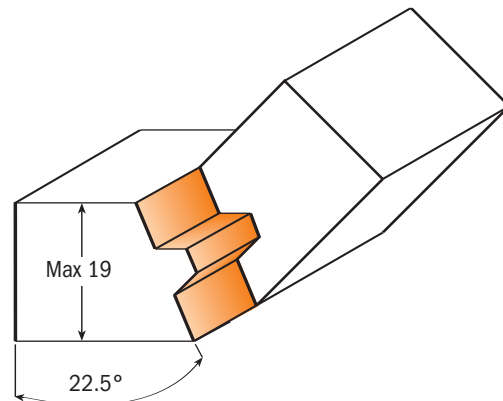

D	I	A	T	ORDER NO.	ORDER NO.
Cutting diameter	Cutting length	Cutting angle	Maximum joint thickness	Shank	Shank
mm	mm		mm	Ø 8mm	Ø 12,7mm
37,3	22,2	22.5°	9,5 ÷ 19	955.005.11	855.505.11
1-15/32					



**8/900.616**



This router allows you to carry out accurate and functional finger joints in a much easier way. Without any adjustment you will be able to work woods with different thicknesses as indicated in the drawing. The bearing allows you to reach a 9,5mm cutting depth. For further cutting depths you need to use a fence.

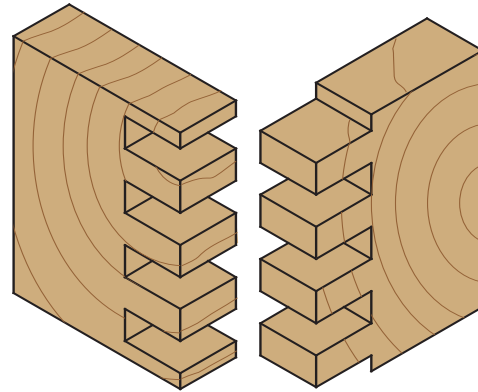
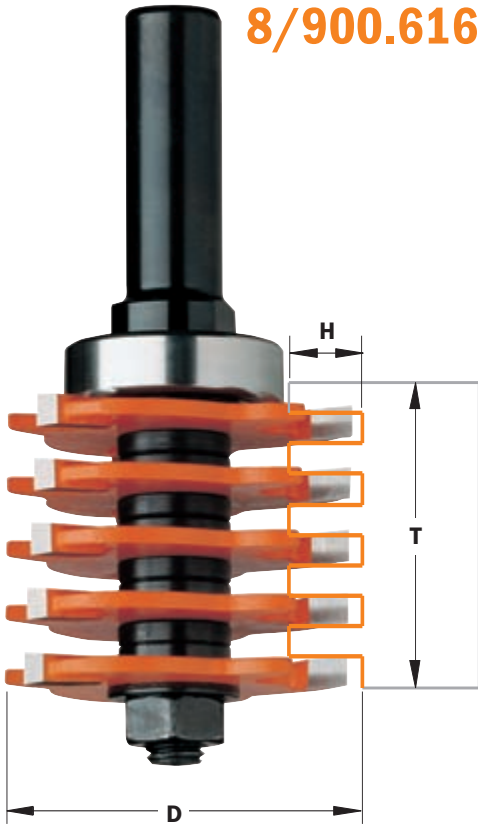

Box joint

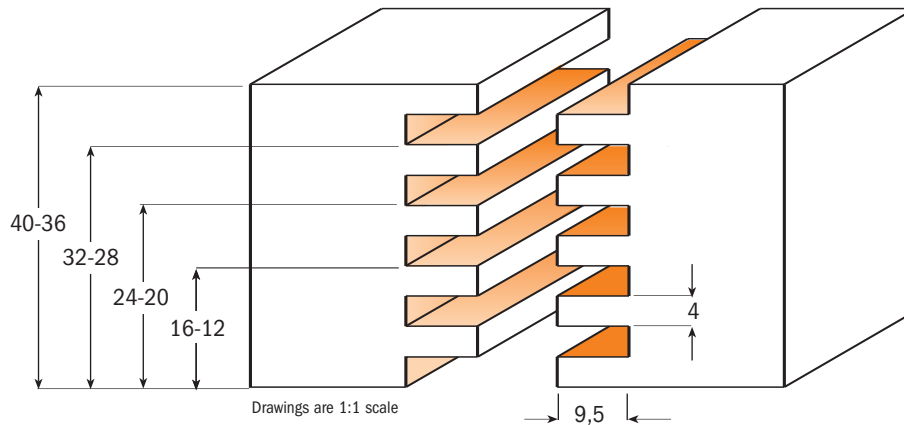

T Maximum joint thickness		D Cutting diameter	H Cutting depth	Spare bearing	ORDER NO. Shank Ø 12mm	ORDER NO. Shank Ø 12,7mm
mm	inches	mm	mm			
12 - 40	1/2 - 1-1/2	47,6	9,5	791.027.00	<b>900.616.11</b>	<b>800.616.11</b>

**Spare parts:** **824.130.00** Ø12,7mm arbor with shims  
**791.020.00** Ø38,1mm bearing (for depth 4,76mm)  
**791.027.00** Ø28,5mm bearing (for depth 9,5mm)  
**541.519.00** 5,8mm spacer  
**990.459.00** Kit with spacers

**924.130.00** Ø12mm arbor with shims  
**791.029.00** Ø34,9mm bearing (for depth 6,35mm)  
**791.011.00** Ø19mm bearing (for depth 14,3mm)  
**990.403.00** 1,6mm washer

**822.340.11** Slot cutter 4mm spacer  
**791.015.00** Ø31,7mm bearing (for depth 8mm)  
**541.515.00** 0,1mm spacer  
**990.020.00** Dado M8

8/900.606



This versatile CMT finger joint bit lets you make one of the most incredibly strong side-to-side or end-to-end joints in all wood and wood composites.

The tightness of the accurately cut joint and the maximum glue surface create a joint that is actually stronger than an unworked piece of wood.

CMT's professional finger joint features two flute design, carbide teeth and six removable cutters so you can make joints in a wide range of stock thicknesses, from 12,7mm to 36mm. Ideal for molding manufacturers and furniture makers.

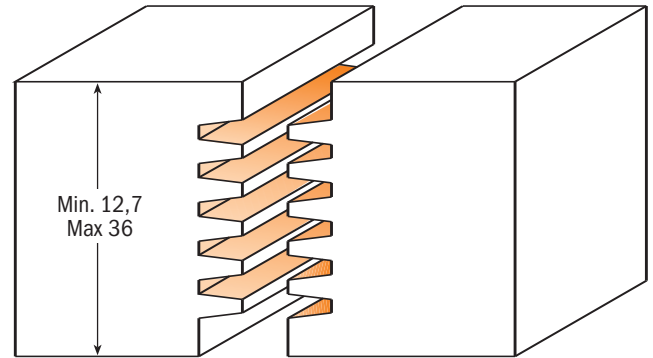
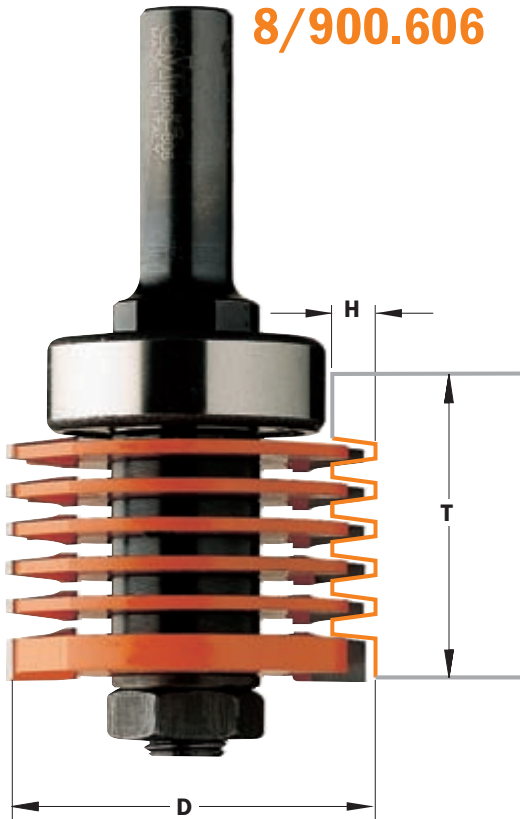

Drawings are 1:1 scale

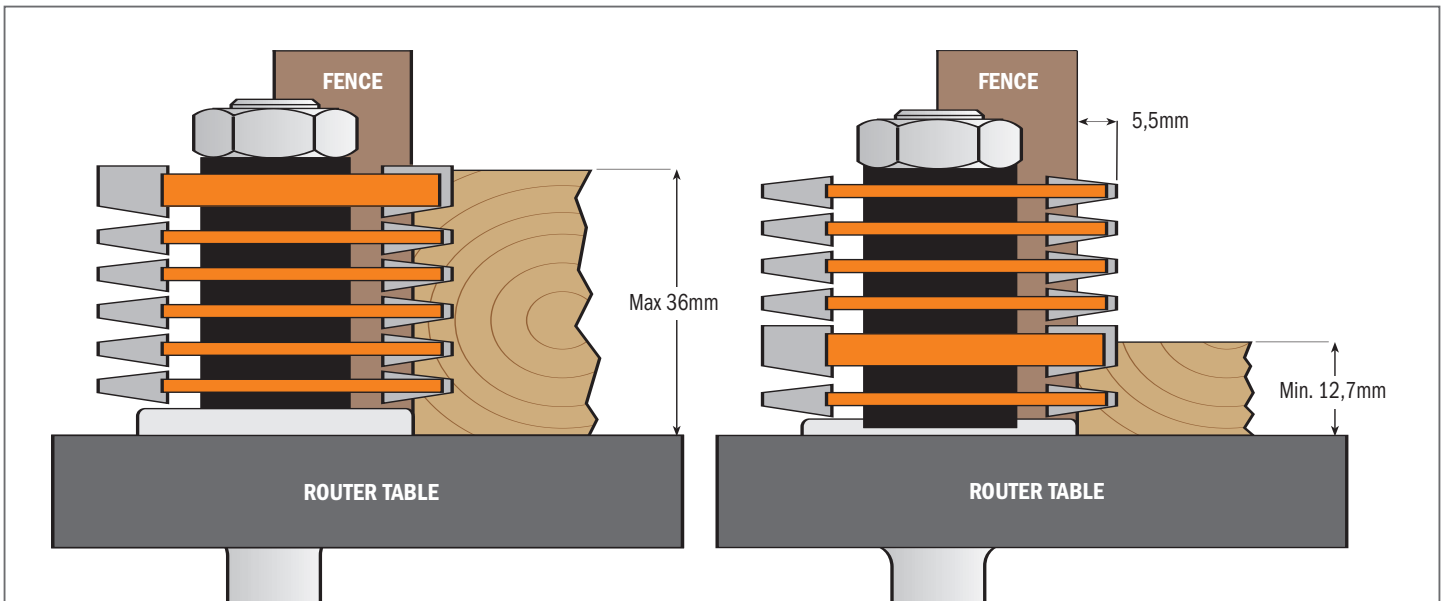

T Maximum joint thickness mm inches	D Cutting diameter mm	H Cutting depth mm	Spare bearing	ORDER NO. Shank Ø 12mm	ORDER NO. Shank Ø 12,7mm
12,7 - 36 1/2 - 1-3/8	47,6	5,5	791.028.00	<b>900.606.11</b>	<b>800.606.11</b>

**Spare parts:** **924.129.00** Ø12mm arbor with shims  
**822.006.11** Slot cutter 5,5mm spacer  
**541.512.00** 2mm spacer  
**990.458.00** Kit with spacer

**824.129.00** Ø12,7mm arbor with shims  
**791.028.00** Ø37mm bearing  
**541.513.00** 0,1mm spacer

**822.005.11** Slot cutter 1,85mm spacer  
**541.511.00** 3mm spacer  
**990.022.00** Nut for arbor M12x1,25

**8/955.506**



If the standard selection of molding and mill work you find in today's lumber shops isn't satisfactory to your woodworking tastes, then look to CMT's molding system instead. With these bits, you can make dozens of elaborate profiles by combining two or more passes. Avoid the average and create your own moldings. Some initial suggestions are illustrated below.

**Safety tips:** Use these bits with a fence. The profiles shown below are milled from heavy stock then refined to the desired shape.

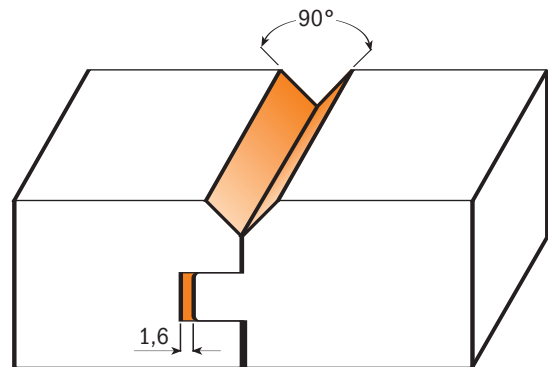
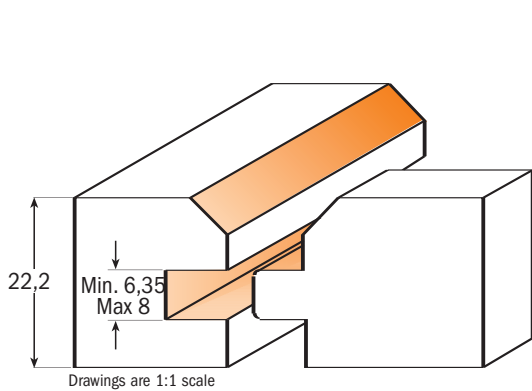
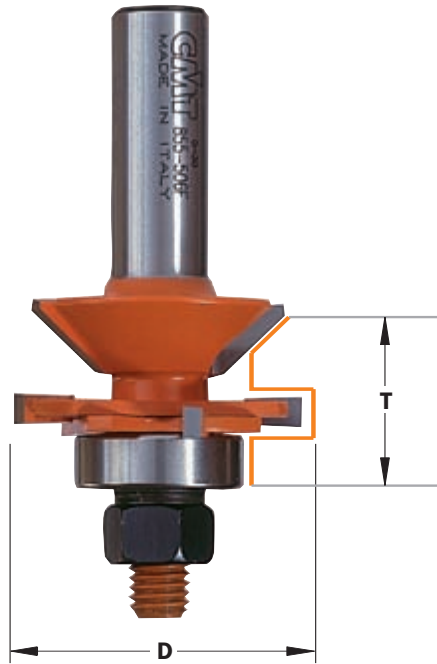

D Cutting diameter		T Maximum joint thickness	ORDER NO. Shank Ø 12mm	ORDER NO. Shank Ø 12,7mm
44,4	1-3/4	19 ÷ 25,4	<b>955.506.11</b>	<b>855.506.11</b>

**Spare parts:** **822.013.11** Slot cutter 8mm spacer  
**791.005.00** Ø22mm bearing  
**541.517.00** 0,5mm spacer

**822.014.11** Slot cutter 4mm spacer  
**541.515.00** 0,1mm spacer  
**990.020.00** Nut for arbor M8

**791.011.00** Ø19mm bearing  
**541.516.00** 0,3mm spacer

8/955.601



Why interrupt the subtle linearity of an all-wood drawer front or cabinet door with a metal knob or handle? Use a CMT finger pull bit and make a harmonious wooden handle. Choose your preference - a template profile made directly in the wood or a European-style hardwood pull as illustrated below.

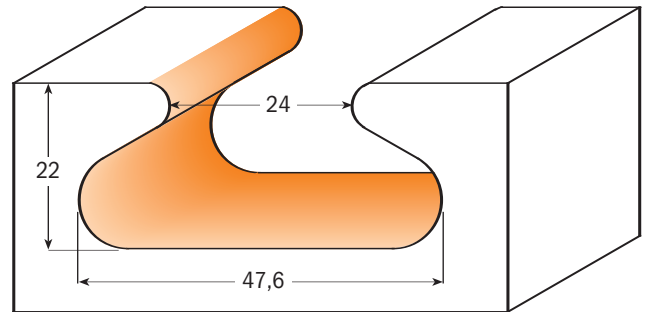
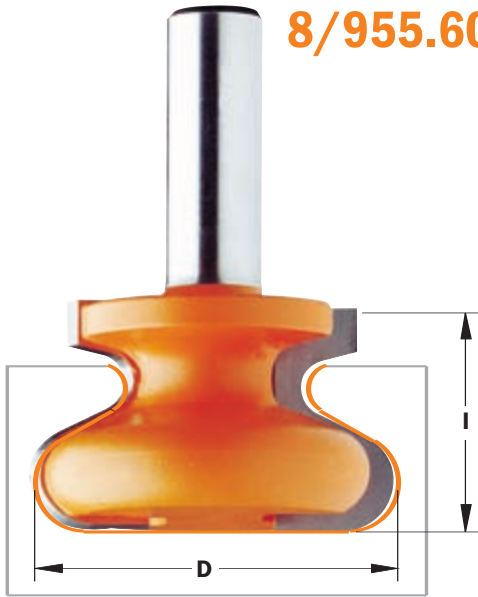

Drawings are 1:1 scale

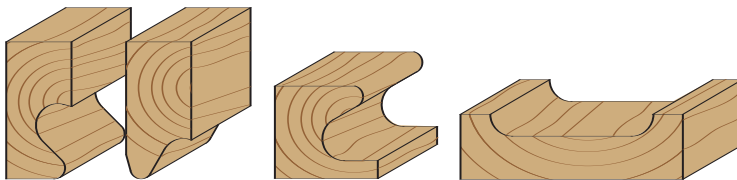

D Cutting diameter		I Cutting length		ORDER NO.	ORDER NO.
mm	inches	mm		Shank Ø 12mm	Shank Ø 12,7mm
47,6	1-7/8	28,5		955.601.11	855.601.11

**For our example we used - CMT Finger Pull bit (item 855.601.11), CMT Slot Cutter (item 822.360.11), 40mm hardwood stock**

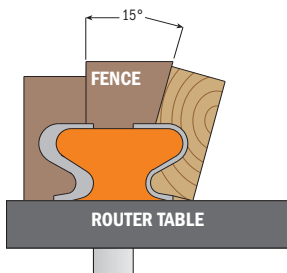

**STEP 1:** assemble the CMT Finger Pull Bit to your router table and set up the fence at 15° to the bit, as illustrated above. Mill the stock using push blocks, being careful not to over-feed. Always use caution when removing large quantities of stock as in this cut.

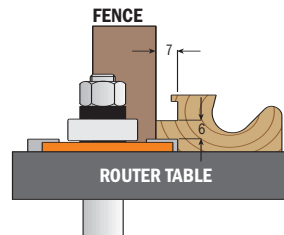

**STEP 4:** keeping the fence in the 7mm position, lower the bit to groove a 6mm tongue, as shown.

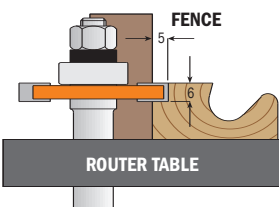

**STEP 2:** assemble the 6mm CMT Slot Cutter to the router table and line up the bit to the top face of the milled handle pull piece. Adjust the fence to make a 5mm depth groove as in the illustration. This is the initial cut in the lip that will be visible on the face of the door.

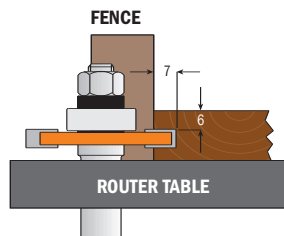

**STEP 5:** to rout the groove for the tongue in the edge of the door, keep the fence in the 7mm position. Adjust the slot cutter 6mm down from the front face of the door and groove as shown in the illustration.

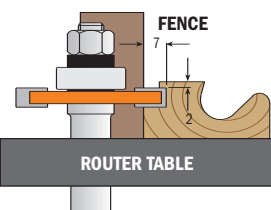

**STEP 3:** lower the bit 2mm and adjust the fence to make a groove 7mm deep. This forms the lip that overlaps the cut edge of the front face of the door, making the hand pull joint secure and more attractive.





**8/955.801**



CMT designed this set so you can create window sashes that are as beautiful as they are functional. As an additional feature, the CMT window sash set will also mill perfectly joining 35mm rail and stile parts for custom made doors. Like all CMT quality bits, this set includes our anti-kickback design feature and our trademark non-stick orange coating. Made of Fatigue Proof® steel with carbide-faced cutting edges for longer life. Each set contains one 38mm bit and one 35mm bit designed for cutting 35mm stock.

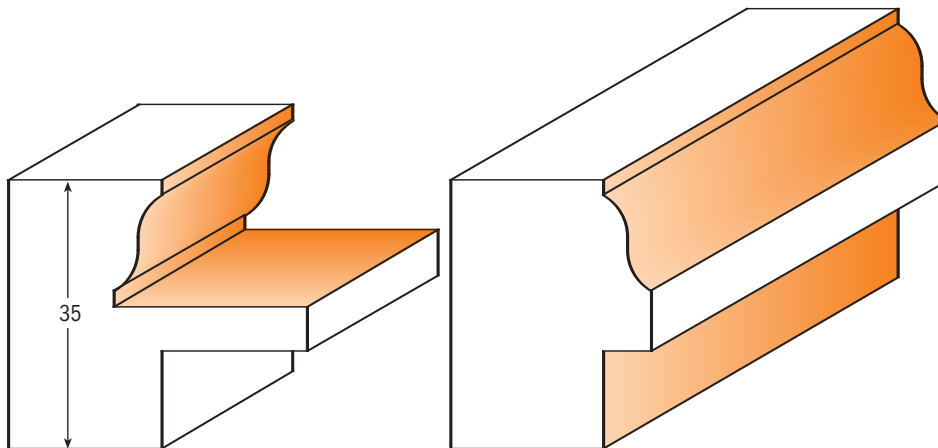
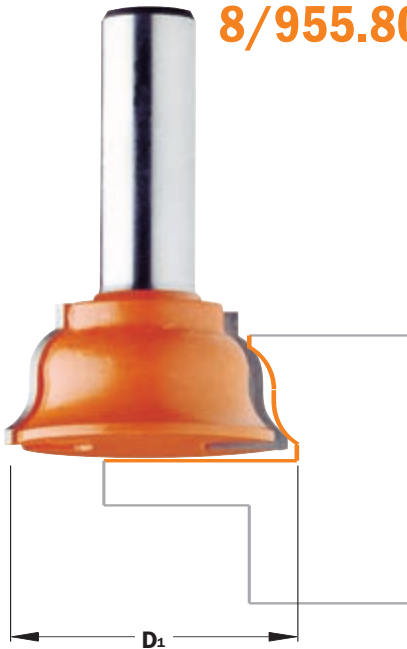

Drawings are 1:1 scale

D1		D2		Spare bearing	ORDER NO.	ORDER NO.
Cutting diameter	Cutting diameter	Cutting diameter	Cutting diameter			
mm	inches	mm	inches		Shank Ø 12mm	Shank Ø 12,7mm
38	1-1/2	35	1-3/8	791.012.00	<b>955.801.11</b>	<b>855.801.11</b>

**Spare parts:** **822.004.11** Slot cutter 14mm spacer  
**541.518.00** 1mm spacer

**791.012.00** Ø22mm bearing

**990.020.00** Nut for arbor M8

**Your CMT set makes it easy!**

In our step-by-step example for window sash construction, we used the following:

- CMT Window Sash Set (item #855.801.11)
- stiles cut 35mm thick
- rails cut 35mm thick
- scrap stock

The CMT Window Sash Set was designed ideally for the construction of windows in 35mm stock, however variations as narrow as 28mm can be used. Stock thicker than 35mm exceeds the milling range of the cutter. Remember to adjust your measurements and cutting depths according to the wood thickness you use. We suggest making a trial joint in scrap stock according to the following steps before milling all of the cope and stick profiles.

**STEP 1 - Measurements and making the tenons**

The ideal thickness of the stiles when using the CMT sash set is 35mm. The desired width of the stiles will determine the length you need to make your tenons, while the length of the stile will represent the desired full height of the sash. When cutting the rails to length, make sure to add the length of the two tenons to the overall length of the rail. The length of the tenons should be at least half the width of the stile. Mill 16mm measuring from the front face of the stock using a table saw, radial saw or router as shown in illustration 1. This measurement remains invariable since it is calculated to the height of the CMT sash routers. The width of the tenon is 6mm. Rotate the stock and mill the other side. For our example, the second milling will be 13mm but this measurement will vary if you are using thinner stock.

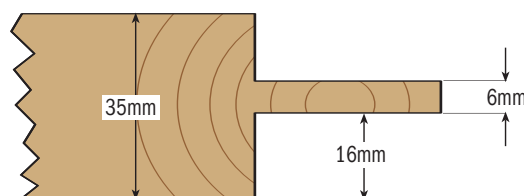

**STEP 2 - Making the cope profile on rails, sash bar and muntins**

To make the cope profile, place the rail face front down on the router table with the tenon flush to the bit as shown in illustration 2. Adjust the fence so the bit mills 6,35mm deeper than the tenon. To mill the sash bar and the muntins (cross bars), position front face down on the router table and mill without changing the height of the bit.

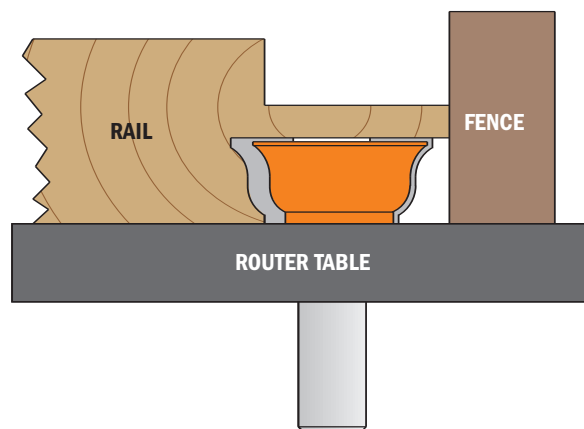

**STEP 3 - Making the stick profile on rails, stile, sash bar and muntins**

To mill the stick profile along the inside edges of all sash parts, place the already milled cope profile front face down on the router table and adjust the sash bit so that the lower edge of the top cutter will exactly touch the upper edge of the tenon as shown in illustration 3. With the rail still face down on the table, turn it so the inside edge of the rail is touching the bit and mill the stick profile. Mill the inside edges of the stiles and mill both edges of the front face of the sash bar and muntins. To cut the slots for the tenons, measure 16mm from the front face of the stiles and rout with a table saw.

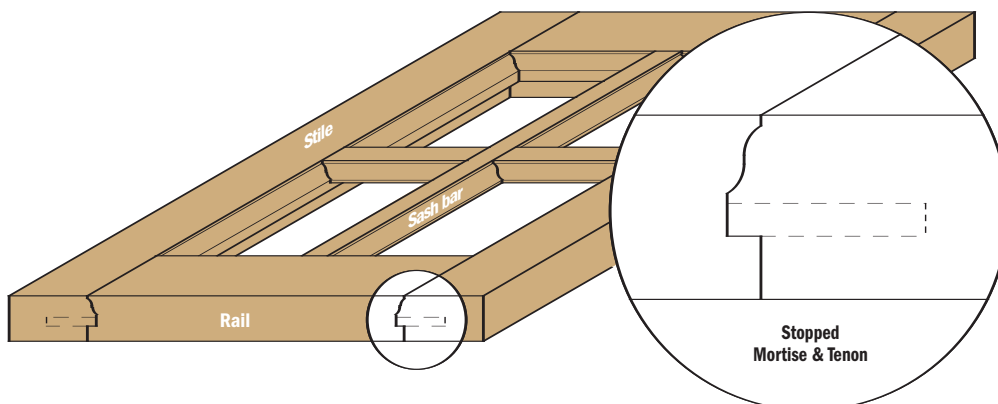
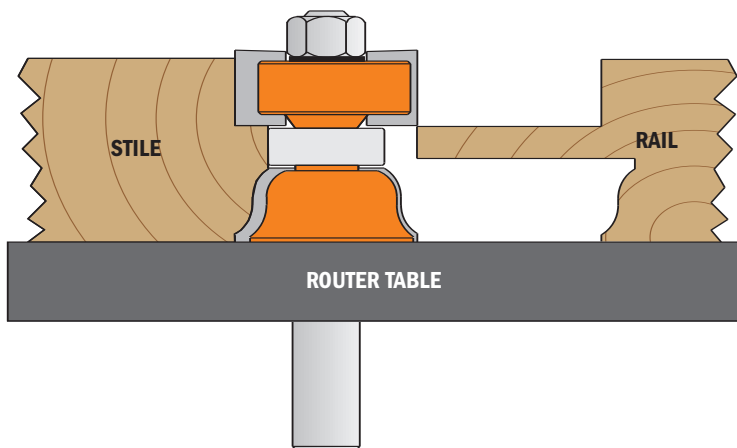

8/990.6



Mill raised panel doors and drawer fronts easily and economically just by putting a CMT vertical raised panel bit in your router\* and a sturdy 90° fence on your router table. Meticulously studied, designed and crafted using the highest technology available, these bits are perfected down to the smallest detail. And just like any true craftsman, we are as proud of our work as you are of yours. Choose any of the three vertical profile designs for the style you want.

\* Recommended for use on routers with a minimum speed of 2-1/4 HP. Routers as low-powered as 1-1/2 HP can be used but we suggest limiting their use to shorter, shallower runs.

**Safety Tips:** The template must be at least 150mm and clamps should be used whenever possible. Three to five passes are recommended to safely and accurately obtain the profile you desire.

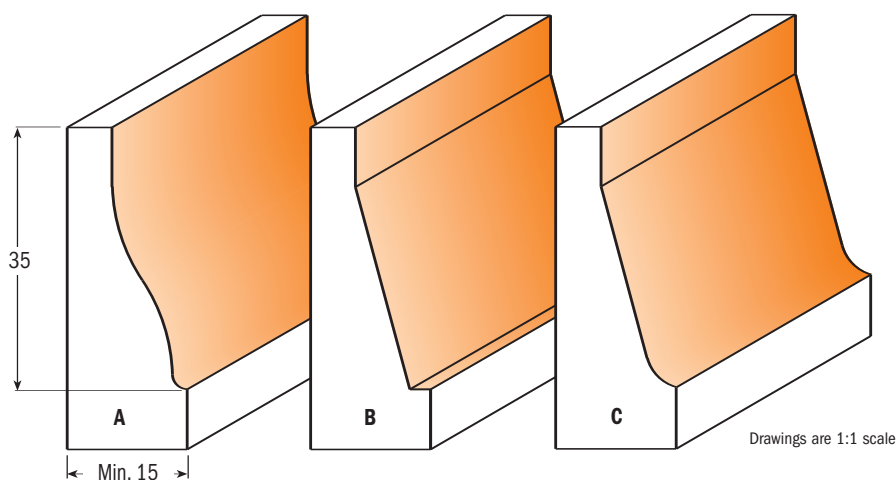
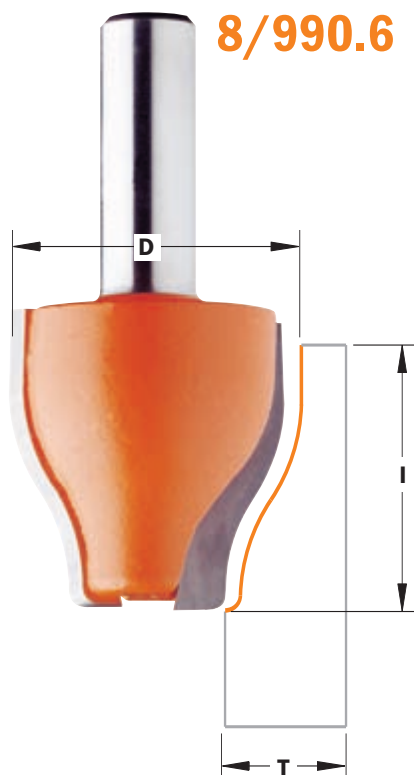

Drawings are 1:1 scale

Profile	D Cutting diameter		I Cutting length mm	T Max stock thickness mm		ORDER NO.	ORDER NO.
	mm	inches				Shank Ø 12mm	Shank Ø 12,7mm
A	38	1-1/2	38	15 ÷ 18		990.601.11	890.601.11
B	38	1-1/2	38	15 ÷ 18		990.602.11	890.602.11
C	38	1-1/2	38	15 ÷ 18		990.603.11	890.603.11

**8/990**



This 89mm diameter bit has a back-cutter which allows milling of both the front and back of the panel in the same cut. An additional 31,7mm diameter bearing promotes safety by allowing you to take two shallow passes.

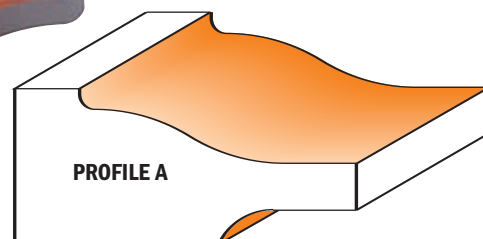
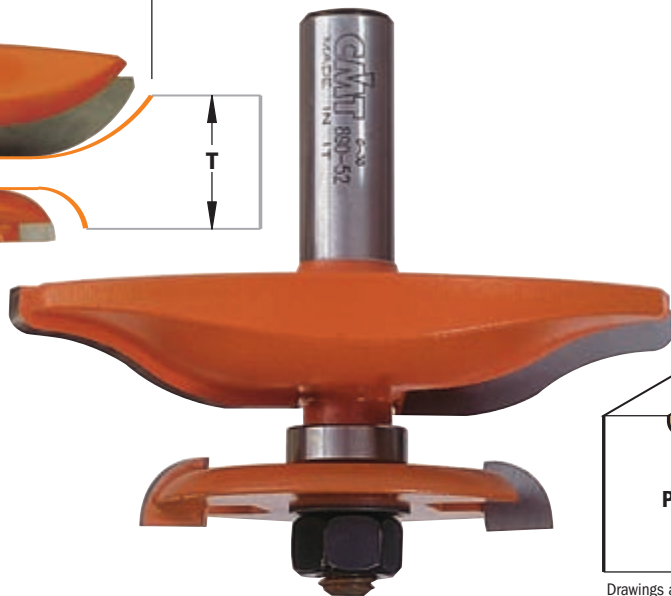
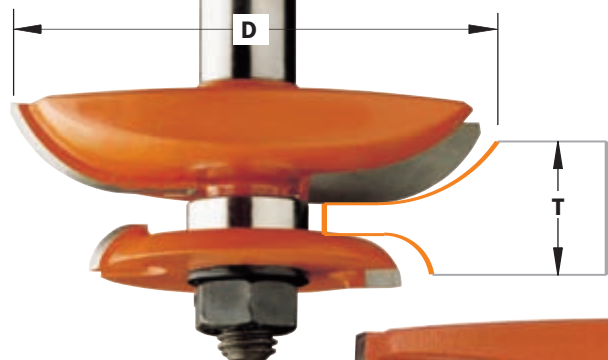

Drawings are 1:1 scale

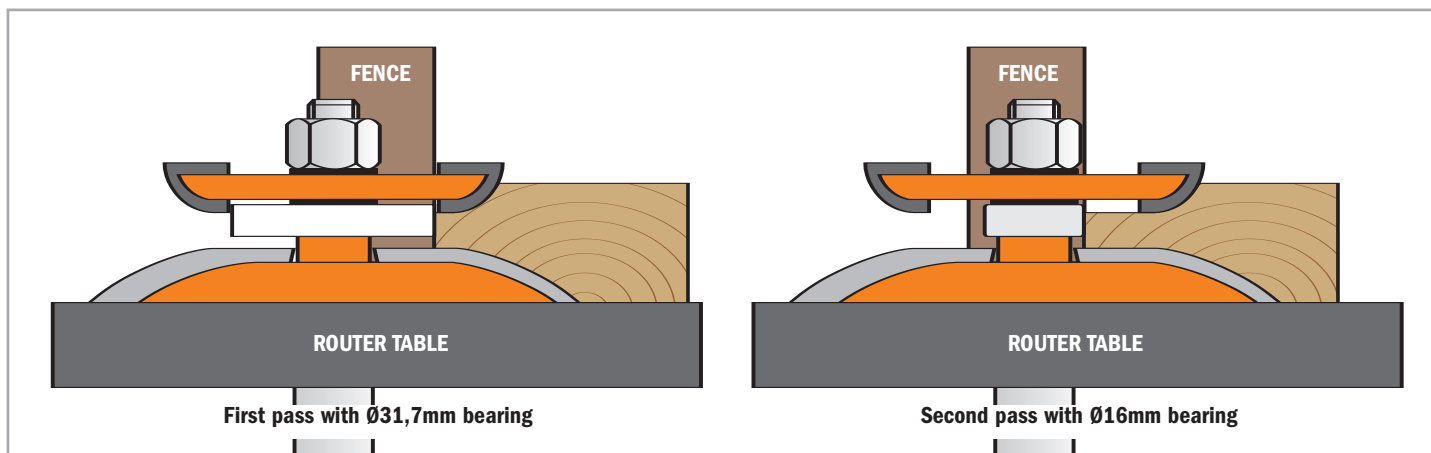
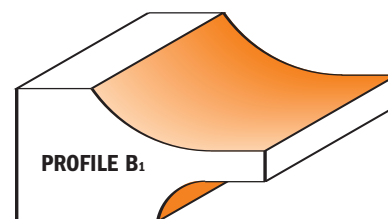
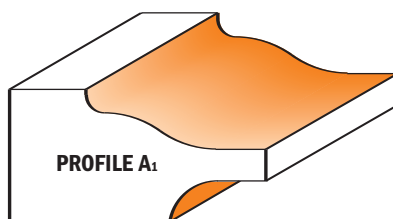
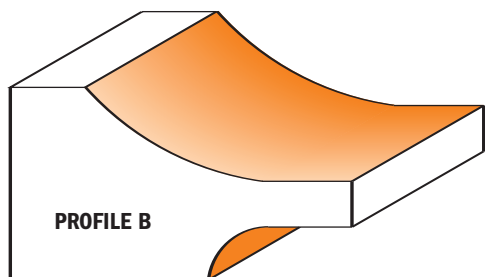

Profile	D Cutting diameter		T Max stock thickness		ORDER NO. Shank Ø 12mm	ORDER NO. Shank Ø 12,7mm
	mm	inches	min.	max		
A	89	3-1/2	19	20,6	<b>990.524.11</b>	<b>890.524.11</b>
B	89	3-1/2	19	25,4	<b>990.527.11</b>	<b>890.527.11</b>
A1	63,5	2-1/2	11,1	17,5	<b>990.534.11</b>	<b>890.534.11</b>
B1	63,5	2-1/2	11,1	17,5	<b>990.537.11</b>	<b>890.537.11</b>

**Spare parts:** **822.007.11** Slot cutter 8mm spacer  
**791.033.00** Ø31,7mm bearing  
**541.518.00** 1,0mm spacer  
**990.407.00** Spring

**822.010.11** Slot cutter 6,35mm spacer  
**541.515.00** 0,1mm spacer  
**990.020.00** Nut for arbor M8, thread

**791.025.00** Ø16mm bearing  
**541.516.00** 0,3mm spacer



8/990.5



We offer you the traditional approach to panel construction with the CMT raised panel bit. Make classic raised panel doors as shown in the profiles below. These raised panel bits have carbide-faced cutting edges and are equipped with our anti-kickback design and orange non-stick coating to further increase your safety when working with larger diameter bits.

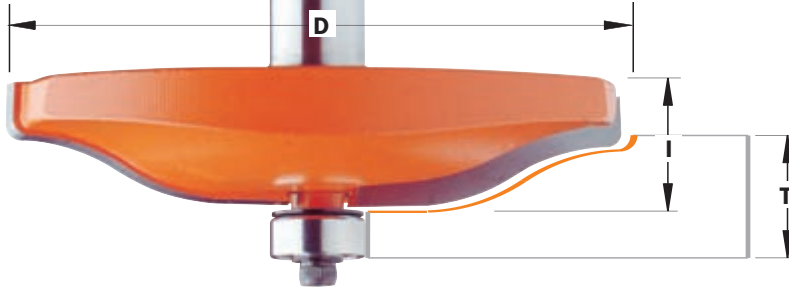

**Safety Tips:** Horizontally employed bits should be used at a lower speed, between 10,000 and 12,000 RPMs. Three to five passes are recommended to safely and accurately obtain the profile you desire. To be used on jigs with at least 2-1/4 HP.

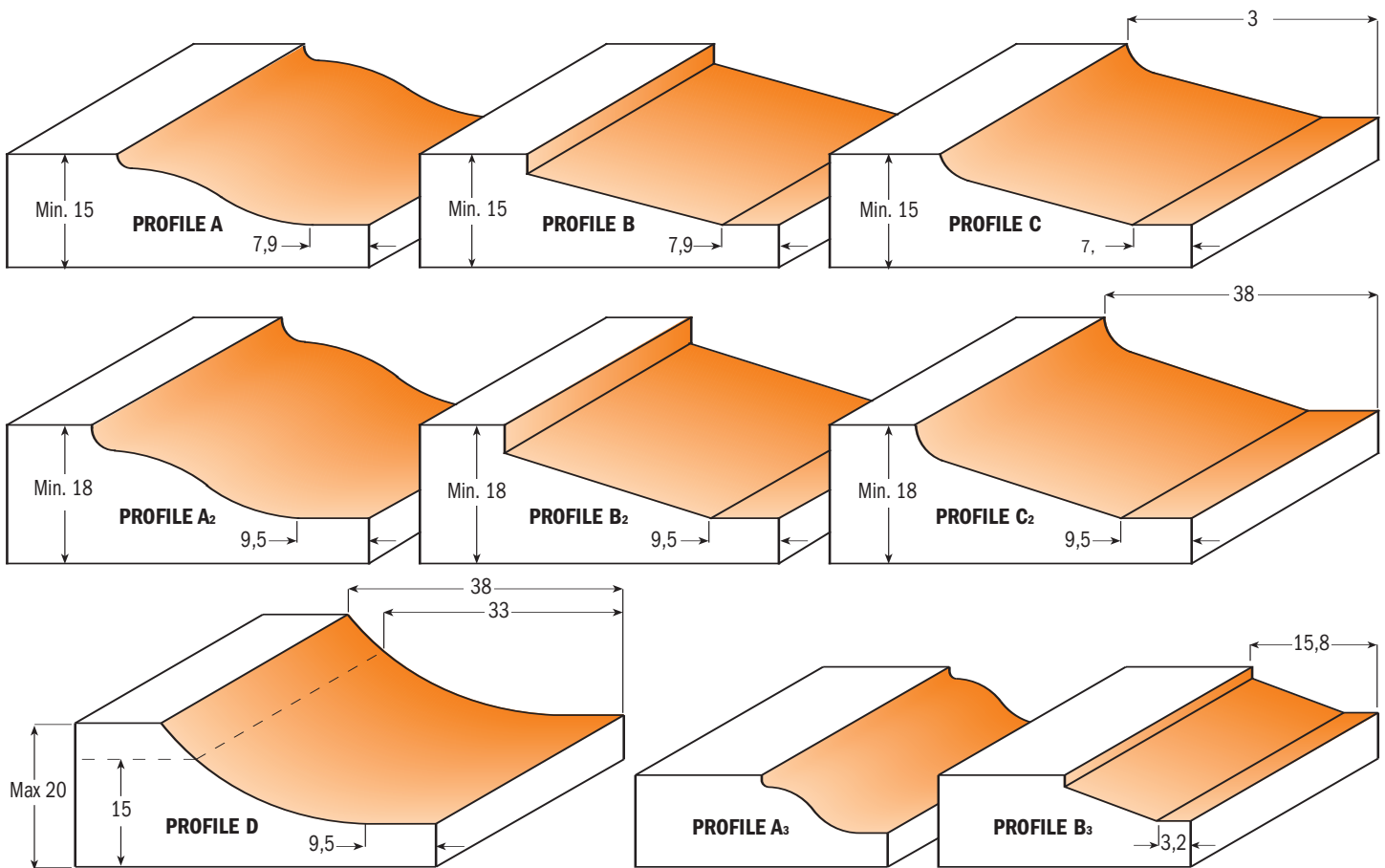

Drawings are 1:1 scale

Profile	D Cutting diameter		I Cutting length mm	T Max stock thickness mm	ORDER NO. Shank Ø 8mm	ORDER NO. Shank Ø 12mm	ORDER NO. Shank Ø 12,7mm
	mm	inches					
A	82,5	3-1/4	15	15 ÷ 18		990.501.11	890.501.11
B	82,5	3-1/4	15	15 ÷ 18		990.502.11	890.502.11
C	82,5	3-1/4	15	15 ÷ 18		990.503.11	890.503.11
A <sub>2</sub>	89	3-1/2	15	18 ÷ 20		990.504.11	890.504.11
B <sub>2</sub>	89	3-1/2	15	18 ÷ 20		990.505.11	890.505.11
C <sub>2</sub>	89	3-1/2	15	18 ÷ 20		990.506.11	890.506.11
D	89	3-1/2	15	15 ÷ 20		990.507.11	890.507.11
A <sub>3</sub>	47,6	1-7/8	9,5	12,7 ÷ 15	990.011.11		
B <sub>3</sub>	47,6	1-7/8	9,5	12,7 ÷ 15	990.012.11		890.512.11

Spare parts: 791.003.00 Ø12,7mm bearing

990.423.00 Ø12,7mm shield

990.058.00 1/8W screw

991.057.00 3/32" hex key

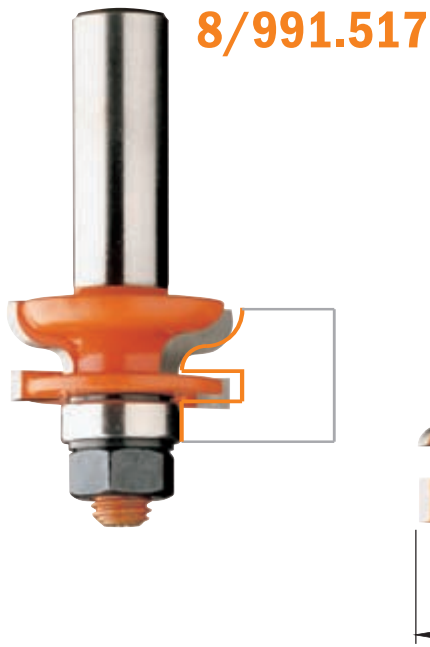

These bits are designed for those special projects that require a smaller panel door. Use these bits with stock from 11,1mm to 17,4mm thick, and build doors as small as 70mm.

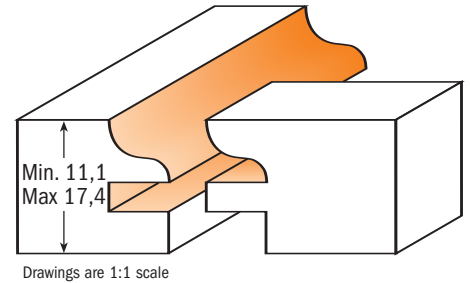

D Cutting diameter		T Max stock thickness	ORDER NO. Shank Ø 12mm	ORDER NO. Shank Ø 12,7mm
mm	inches	mm		
31,75	1-1/4	11 ÷ 17,5	<b>991.517.11</b>	<b>891.517.11</b>

**Spare parts:** **822.008.11** Slot cutter 4mm spacer  
**541.515.00** 0,1mm spacer  
**990.020.00** Nut for arbor M8, thread

**822.009.11** Slot cutter 6mm spacer  
**541.516.00** 0,3mm spacer

**791.025.00** Ø16mm bearing  
**541.518.00** 1,0mm spacer

**“Lonnie Bird’s” rail and stile set**

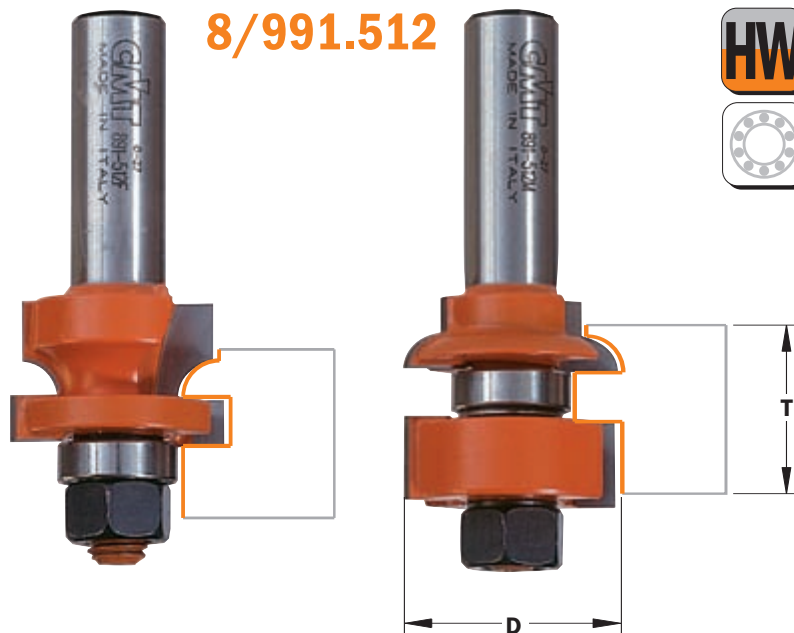

Designed for fine furniture construction, these bits mill a delicate 4,75mm thumbnail profile in stock from 15,8mm to 20,6mm.

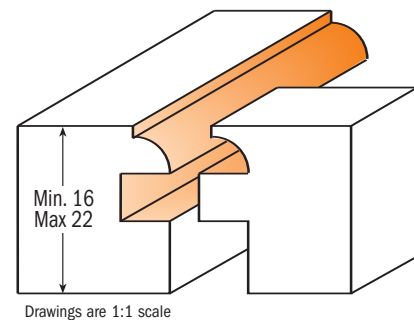

D Cutting diameter		T Max stock thickness	ORDER NO. Shank Ø 8mm	ORDER NO. Shank Ø 12,7mm
mm	inches	mm		
28,7	1-1/8	16 ÷ 22	<b>991.012.11</b>	<b>891.512.11</b>

**Spare parts:** **822.011.11** Slot cutter 6,35mm spacer  
**541.515.00** 0,1mm spacer  
**990.020.00** Nut for arbor M8, thread thread

**822.012.11** Slot cutter 10,8mm spacer  
**541.516.00** 0,3mm spacer

**791.025.00** Ø16mm bearing  
**541.518.00** 1,0mm spacer

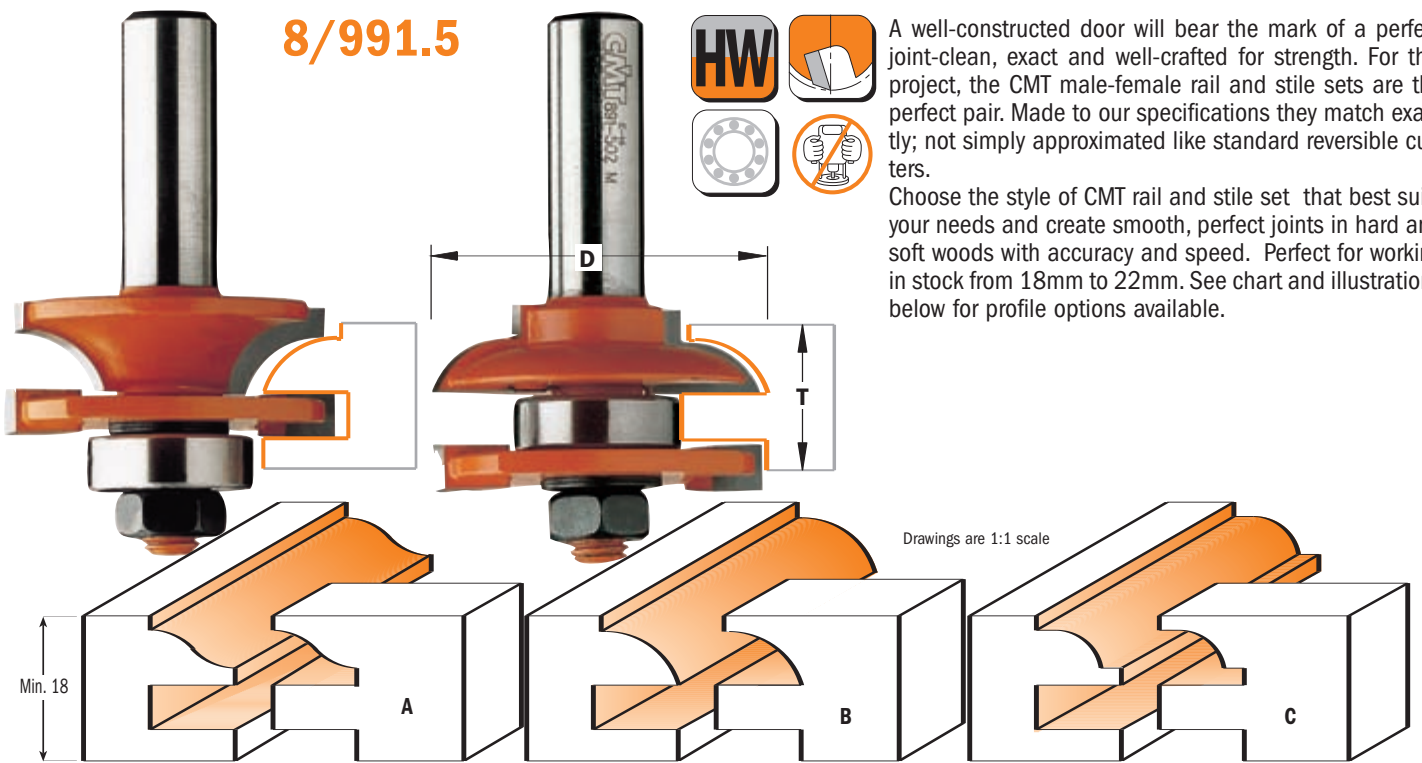

A well-constructed door will bear the mark of a perfect joint-clean, exact and well-crafted for strength. For this project, the CMT male-female rail and stile sets are the perfect pair. Made to our specifications they match exactly; not simply approximated like standard reversible cutters.

Choose the style of CMT rail and stile set that best suits your needs and create smooth, perfect joints in hard and soft woods with accuracy and speed. Perfect for working in stock from 18mm to 22mm. See chart and illustrations below for profile options available.

Profile	D Cutting diameter		T Max stock thickness	ORDER NO. Shank Ø 12mm	ORDER NO. Shank Ø 12,7mm
	mm	inches			
A	44,4	1-3/4	18 ÷ 22	<b>991.501.11</b>	<b>891.501.11</b>
B	44,4	1-3/4	18 ÷ 22	<b>991.502.11</b>	<b>891.502.11</b>
C	44,4	1-3/4	18 ÷ 22	<b>991.503.11</b>	<b>891.503.11</b>

**Spare parts:** **822.003.11** Slot cutter 6mm spacer      **541.515.00** 0,1mm spacer      **541.517.00** 0,5mm spacer  
**791.012.00** Ø22mm bearing      **541.516.00** 0,3mm spacer      **990.020.00** Nut for arbor M8, thread

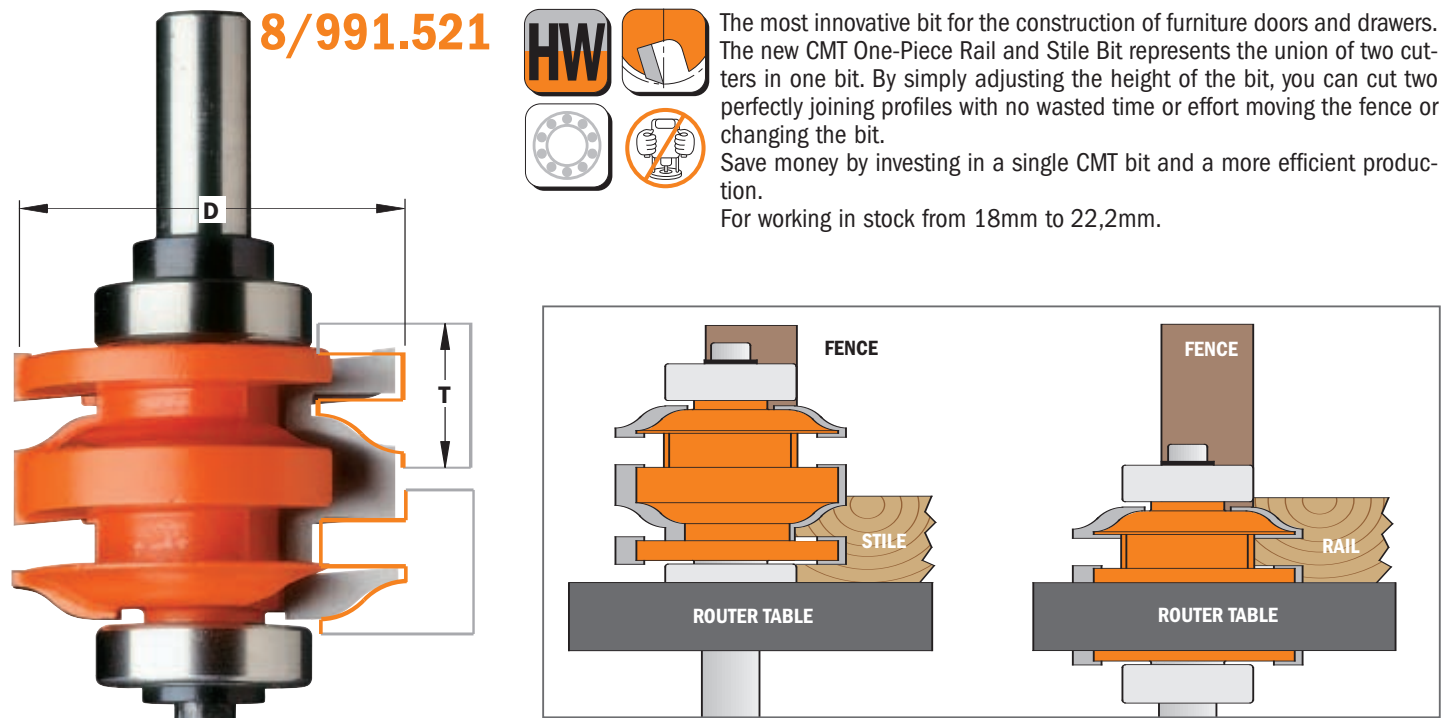

The most innovative bit for the construction of furniture doors and drawers. The new CMT One-Piece Rail and Stile Bit represents the union of two cutters in one bit. By simply adjusting the height of the bit, you can cut two perfectly joining profiles with no wasted time or effort moving the fence or changing the bit.

Save money by investing in a single CMT bit and a more efficient production.

For working in stock from 18mm to 22,2mm.

Profile	D Cutting diameter		T Max stock thickness	ORDER NO. Shank Ø 12mm	ORDER NO. Shank Ø 12,7mm
	mm	inches			
A	50,8	2	18 ÷ 22	<b>991.521.11</b>	<b>891.521.11</b>

**Spare parts:** **791.027.00** Ø28,6mm bearing      **541.002.00** Stop collar for Ø12,7mm shanks      **541.551.00** Shield for screw M5  
**541.005.00** Stop collar for Ø12mm shanks      **990.010.00** Screw M5      **991.056.00** 1,5mm hex key

In our step-by-step example of panel door construction, we used the following:

- CMT Rail & Stile set (item #891.502.11)
- CMT Reverse Glue Joint (item #855.501.11)
- pre-cut to length stiles - 19mm thick x 57mm wide
- pre-cut to length rails - 19mm thick x 57mm wide
- panel - 16mm thick
- scrap stock

The CMT Rail & Stile set was designed ideally for the construction of panel doors from 19mm thick stock, however any variation of size up to 22mm thick can be used. Remember to adjust your measurements and cutting depths according to the wood thickness you use.

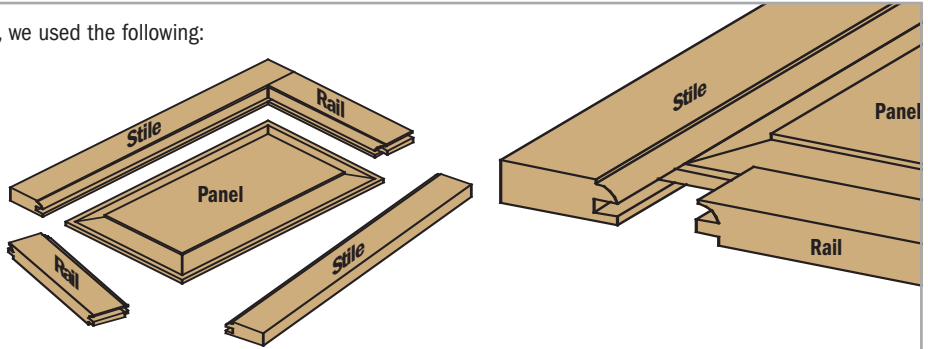

**ILLUSTRATION A**

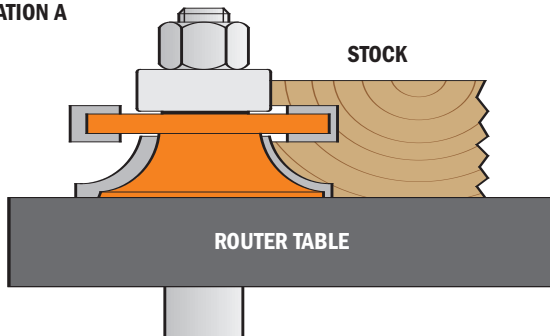

**ILLUSTRATION B**

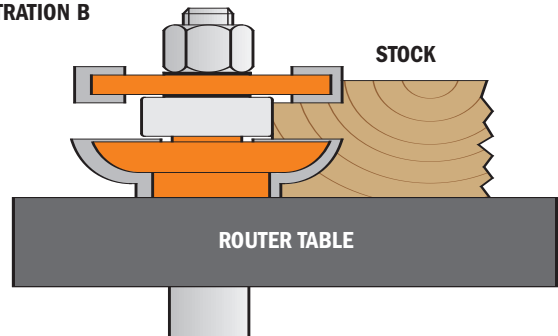

**MILLING THE RAILS AND STILES**

First make trial cuts of the cope profile (rail) and the stick profile (stile) in scrap stock and check the accuracy of the joint. This is extremely important when working at maximum thickness (22mm). Make sure your stock is flat and cut straight with square edges. Using the CMT Stile Bit shown in illustration A, place the stock front face-down on the router table and mill the stick profile in the stile and rail pieces. To mill the rails, use the CMT Rail Bit shown in illustration B, position the rails face-down on the router table and mill the cope profile in the ends. If you are milling cope and stick profiles before cutting the rails and stiles to length, be sure to make the proper calculations before cutting the rails. The stiles are the same length as the door. The rails must be calculated by the following equation (CMT standard tenon length is 22mm):

(total door width - sum of stile widths) + sum of 2 tenons = total rail length  
 therefore, using our example measurements listed above, for a 300mm cabinet door:  
 300 - 111 + 11 = 200mm

**GLUEING UP PANELS**

If the panel requires a width greater than the width of your stock, you will need to edge glue stock for the central floating panel. This is simply accomplished using the CMT Reverse Glue Joint bit. For making a two panel glue joint, place the first panel front face down on the router table and accurately centre the wood to the bit: Adjust the bit according to the thickness of the wood you are cutting by lining up the cut edge of the wood to the centre point of the bit as illustrated in illustration B and mill the cut edge of the wood. Place the second panel front face up and repeat the milling process. This assures you will have the best side of your stock as a front face. If a third panel is required, mill one cut edge of the piece as instructed above, turn the piece over and run the other edge. Assemble the reverse cut pairs together for beautiful, strong joints that match up perfectly.

**MILLING THE FLOATING PANEL**

Make trial cuts in scrap stock to create a tongue that fits snugly into the groove in the stile without forcing it. To cut your panel to size be sure to make the proper calculations, taking into account the length of the tongue. The CMT Raised Panel Bit in our example has a standard tongue length of 8mm (The New CMT Raised Panel Bit profile has a 9,5mm tongue).

Use the following equation:  
 (Total door length - Sum of Stile widths) + Sum of 2 Tongues = Overall Panel Length

Therefore, using our example measurements listed above for a 600mm long cabinet door: (600 - 116) + 16mm = 510mm

And accordingly:

(Total door width - Sum of Stile widths) + Sum of 2 Tongues = Overall Panel Width.

Once the panel has been cut to proper dimensions, position the panel front face side down on the router table tongue as shown in illustration C and use the CMT Raised Panel Bit to mill the tongue. ATTENTION: this bit is capable of removing large amounts of stock. To safely and effectively produce the profile you want, we suggest making several shallow passes. It can be dangerous to try to mill the entire profile in a single run.

**ILLUSTRATION C**

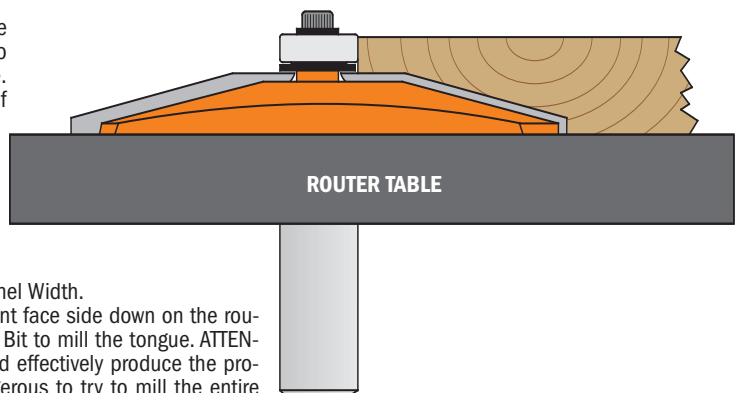
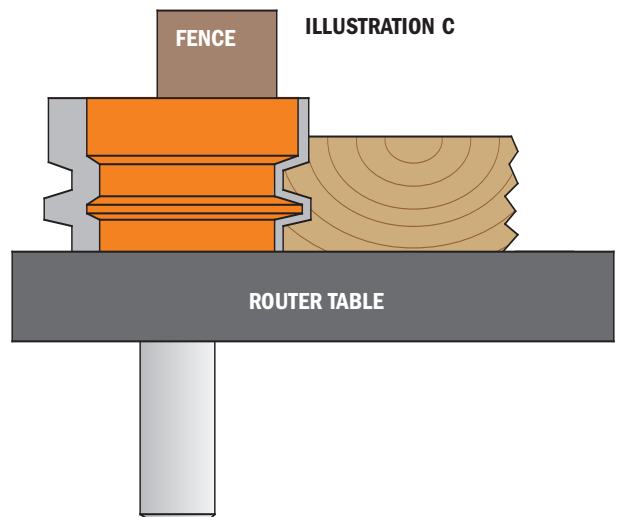



**791**

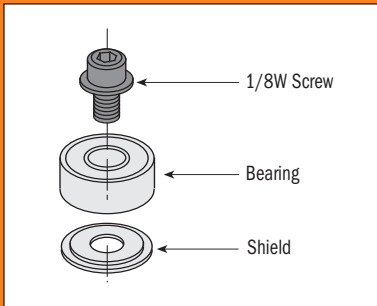

**Be Sure:** to keep the black washer right side up to correspond with the bearing rotation during reassembly.

**\* 10° Delrin® conical bearing**



**\*\*Delrin® triangular bearing**

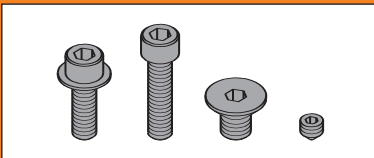
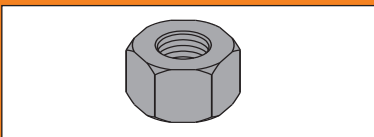
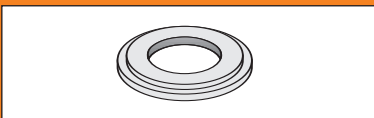

**Bearing**

D Cutting diameter		d Small diameter		Thickness mm	ORDER NO.
mm	inches	mm	inches		
6,35	1/4	3,2	1/8	3,2	791.035.00
9,5	3/8	4,76	3/16	3,2	791.002.00
12,7	1/2	4,76	3/16	5	791.003.00
12,7	1/2	6,35	1/4	4,8	791.010.00
13		5		4	791.022.00
13		6		5	791.023.00
15		6		5	791.024.00
15,8	5/8	4,76	3/16	5	791.018.00
15,8	5/8	6,35	1/4	5	791.009.00
16		5		5	791.006.00
16		8		5	791.025.00
19	3/4	4,76	3/16	7,5	791.019.00
19		6		6	791.007.00
19	3/4	6,35	1/4	7	791.004.00
19		8		6	791.034.00
19	3/4	12,7	1/2	4	791.011.00
22		8		6	791.012.00
22		8		7	791.005.00
22,2	7/8	4,76	3/16	7,5	791.017.00
22,2	7/8	9,52	3/8	7	791.021.00
22,2	7/8	12,7	1/2	7	791.013.00
24		8		8	791.036.00
28		12		8	791.026.00
28,5	1-1/8	4,76	3/16	8,4	791.014.00
28,5	1-1/8	8		8,5	791.030.00
28,5	1-1/8	12,7	1/2	8	791.027.00
31,7	1-1/4	8		5	791.033.00
31,7	1-1/4	12,7	1/2	10	791.015.00
34,9	1-3/8	4,76	3/16	11,5	791.016.00
34,9	1-3/8	8		11,6	791.031.00
34,9	1-3/8	12,7	1/2	11	791.029.00
37		12		12	791.028.00
38,1	1-1/2	12,7	1/2	13,3	791.020.00
19	3/4	4,76	3/16	6,8	791.041.00*
12,7	1/2	4,76	3/16	5,8	791.042.00**
19	3/4	4,76	3/16	7	791.043.00**

**Shield for bearing**

**990.422/423**

DESCRIPTION	ORDER NO.
Ø9,5mm shield	990.422.00
Ø12,7mm shield	990.423.00

**Nut for arbor**

Nut for arbor M8, thread	990.020.00
Nut for arbor M12x1,25 thread	990.022.00

**Screw for bearing**

**990**

DESCRIPTION	ORDER NO.
Screw 1/8W x 3/8"	990.058.00
Screw 1/8W x 1/2"	990.059.00
Screw TSPEI M4x6	990.004.00
Screw TSPEI M3x3 (for 541 stop collar)	990.005.00
Screw TSPEI M5x12 (for 823)	990.055.00

**Hex key for bearing screws**

**991**

DESCRIPTION	ORDER NO.
3/32" hex key (for 1/8W screw)	991.057.00
2,5mm hex key (for M4 screw)	991.062.00
1,5mm hex key (for M3 screw)	991.056.00

**Stop collar for top bearing bits**
**541**

DESCRIPTION	ORDER NO.
Stop collar for Ø6mm	541.003.00
Stop collar for Ø6,35mm	541.001.00
Stop collar for Ø8mm	541.004.00
Stop collar for Ø9,5mm	541.006.00
Stop collar for Ø12mm	541.005.00
Stop collar for Ø12,7mm	541.002.00

**Shield for assembly**
**541**

d Ø small mm	D Ø large mm	Thickness mm	ORDER NO.	d Ø small mm	D Ø large mm	Thickness mm	ORDER NO.
3,25	9	1,6	541.550.00	8	14,7	5,8	541.519.00
3,25	15,8	2	541.552.00	12	20	2	541.512.00
5,2	15,8	2,5	541.551.00	12	20	3	541.511.00
6,4	9,52	2,2	541.514.00	12	21	0,1	541.513.00
8	14	0,1	541.515.00	12	21	0,3	541.520.00
8	14	0,3	541.516.00	12	21	1,59	541.521.00
8	14	0,5	541.517.00	12	21	3,18	541.522.00
8	14	1	541.518.00	12	21	6,16	541.523.00
8	14,7	3	541.500.00	12	21	1	541.524.00
8	14,7	4	541.501.00	12	21	0,5	541.525.00

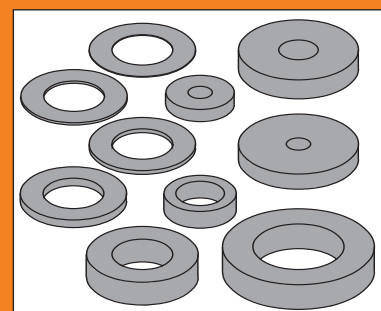
**Bushings**
**799**

d Inside diameter mm	D Outside diameter mm	L Overall length mm	ORDER NO.
6	8	25	799.060.00
6	9,5	25	799.160.00
6	12	25	799.260.00
6,35	8	25	799.064.00
6,35	9,5	25	799.164.00
6,35	12,7	25	799.264.00
8	9,5	25	799.180.00
8	10	25	799.280.00
8	12	25	799.380.00
8	12,7	25	799.480.00
9,5	12,7	25	799.001.00
10	12	25	799.100.00
13	16	45	799.130.00

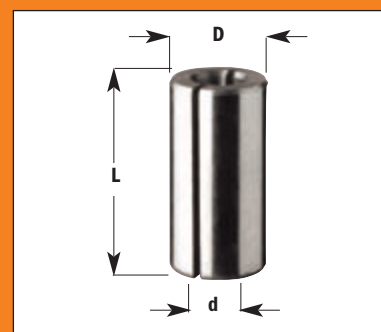

**Collet for CMT, DeWalt, Felisatti, Fein, Metabo hand-router**
**796.8**

D <sub>3</sub> For shank diameter mm	ORDER NO.
6	796.860.00
6,35	796.864.00
8	796.880.00
9,5	796.895.00
10	796.900.00
12	796.920.00
12,7	796.927.00

**Collet for Freud/Casals hand-router**
**796.780**

D <sub>3</sub> For shank diameter mm	ORDER NO.
8	796.780.00

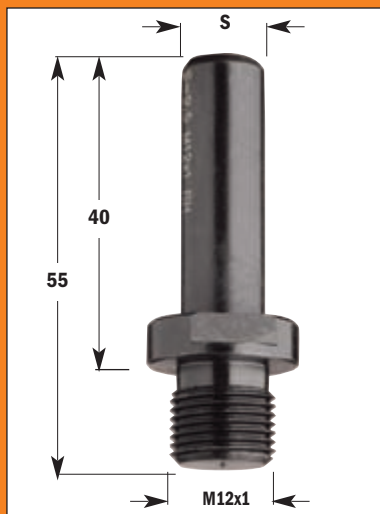



**Arbor**

**797**

S Shank diameter mm		ORDER NO.
10		797.100.00
12		797.120.00
12,7		797.127.00

**TECHNICAL DETAILS:**

- Super strength steel
- Precision machined for accuracy.

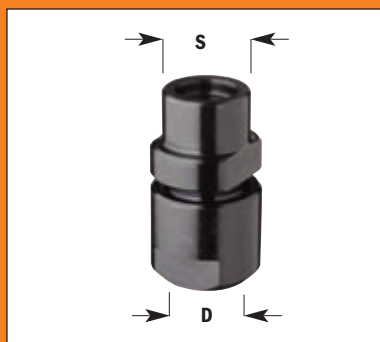

**Collet chucks**

**796**

S Shank diameter	D For shank diameter mm	ORDER NO.
M10	6 - 6,35 - 8 - 9,5	796.100.00
M12x1	6 - 6,35 - 8 - 9,5	796.000.00
M12x1	10 - 12 - 12,7	796.121.00

**TECHNICAL DETAILS:**

- Super strength steel
- Precision machined for accuracy.

**Collet non included.**

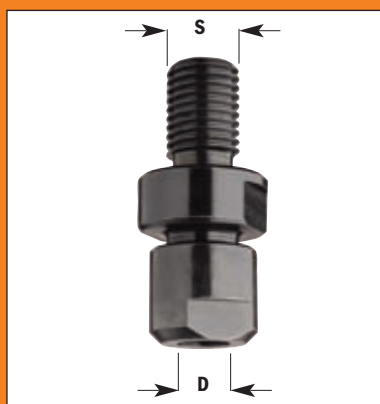

**Collet chucks**

**796**

S Shank diameter	D For shank diameter mm	ORDER NO.
M14x2	6 - 6,35 - 8 - 9,5	796.140.00
M14x2	10 - 12 - 12,7	796.141.00
M16x2	6 - 6,35 - 8 - 9,5	796.160.00
M16x2	10 - 12 - 12,7	796.161.00

**TECHNICAL DETAILS:**

- Super strength steel
- Precision machined for accuracy.

**Collet non included.**



**Collet 796**

**796.500/600**

D <sub>3</sub> For shank diameter mm	ORDER NO.
6	796.560.00
6,35	796.564.00
8	796.580.00
9,5	796.595.00
10	796.600.00
12	796.620.00
12,7	796.627.00

**Router collet extension**
**796.001**

S Shank diameter mm	D For bit diameter mm	ORDER NO.
12	12	796.002.00
12,7	12,7	796.001.00

**TECHNICAL DETAILS:**

- Super strength steel
- Precision machined for accuracy.

**Collet included**

**Arbors**
**798**

S Shank diameter	S <sub>1</sub> Shank diameter	ORDER NO.
M10	M10	798.101.00
M10	M12x1	798.102.00
M12x1	M10	798.121.00
M12x1	M12x1	798.122.00

**TECHNICAL DETAILS:**

- Super strength steel
- Precision machined for accuracy.

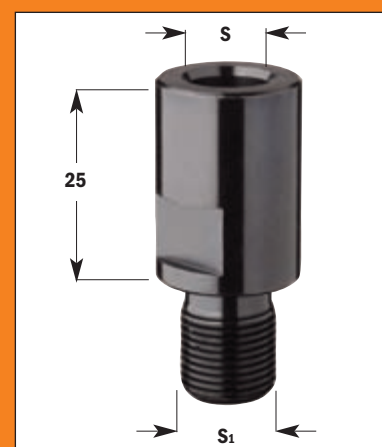

**Collet chuck "ER20"**
**796**

S Shank diameter	D For bit diameter mm	ORDER NO.
M12x1,75	6 ~ 12,7	796.122.00
M14x2	6 ~ 12,7	796.142.00
M16x2	6 ~ 12,7	796.162.00

**Spare parts:** 992.483.01 Clamping nut

**TECHNICAL DETAILS:**

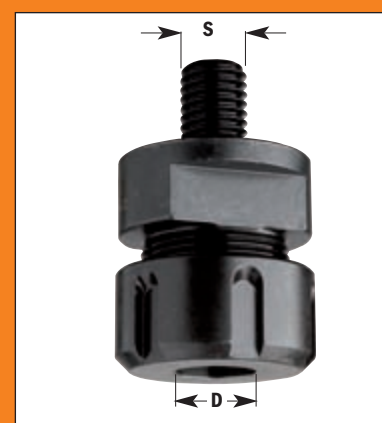
- Super strength steel
- Precision machined for accuracy.

**Collet non included**

**Precision collet "ER20" for item 796.122/142/162**
**184**

D <sub>3</sub> For bit diameter mm	ORDER NO.
3	184.030.20
6	184.060.20
6,35	184.064.20
8	184.080.20
10	184.100.20
12	184.120.20
12,7	184.127.20







# Router bits with replaceable knives



Straight router bits with knives 116



Straight router bits with knives 117



Pattern bits with knives 117



Straight router bits with knives 118



Flush trim bits with knives 119



Chamfer bits with knives 120



Chamfer bits with knives 120



Rabbeting bits with knives 120



Roundover bits with knives 122





**651**  
**652**



Straight router bit with one replaceable miniknive and fixing wedge. Radial and axial groove for better positioning and security of axial knife moving. For finishing and routing, plunge cutting and grooving in boards materials (laminated DTD, MDF) and hard wood.  
For use on portable Routers or CNC machining centers.

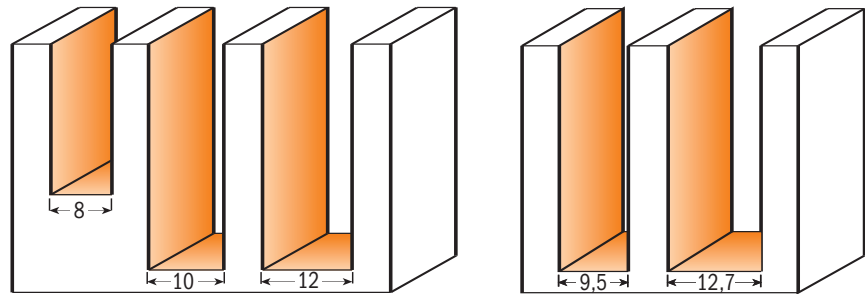

Drawings are 1:1 scale

D Cutting diameter		I Cutting length	L Overall length	Spare knives	ORDER NO. Shank Ø 6,35mm	ORDER NO. Shank Ø 8mm	ORDER NO. Shank Ø 12mm	ORDER NO. Shank Ø 12,7mm
mm	inches	mm	mm					
8	5/16	20	60	790.200.01	<b>651.079.11</b>	<b>651.080.11</b>		
8	5/16	20	69,5	790.200.01			<b>651.081.11</b>	
8	5/16	20	70,7	790.200.01				<b>651.681.11</b>
9,5	3/8	30	70,1	790.300.01	<b>651.095.11</b>			
9,5	3/8	30	80,1	790.300.01				<b>651.695.11</b>
10		30	70,1	790.300.01		<b>651.100.11</b>		
10		30	80,1	790.300.01			<b>651.101.11</b>	<b>651.701.11</b>
12		30	70,1	790.300.01		<b>651.120.11</b>		
12		30	80,1	790.300.01			<b>651.121.11</b>	<b>651.721.11</b>
12		50	102,7	790.500.01		<b>652.121.11</b>		<b>652.621.11</b>
12,7	1/2	30	70,1	790.300.01	<b>651.127.11</b>			
12,7	1/2	30	80,1	790.300.01				<b>651.727.11</b>
12,7	1/2	50	102,7	790.500.01				<b>652.628.11</b>
14		30	73,1	790.300.01		<b>651.140.11</b>		

**Spare parts:** **790.200.01** Knives 20 x 4,1 x 1,1      **790.300.01** Knives 30 x 5,5 x 1,1      **990.071.00** Torx screw M2,5x5  
**651.999.01** Wedge for knives Ø8mm      **651.999.02** Wedge for knives Ø9,5-10-12-12,7mm      **991.063.00** Torx key T8  
**790.500.01** Knives 50 x 5,5 x 1,1      **651.999.03** Wedge for knives Ø12-12,7mm

## Pattern bits with knives



**652B**



Straight trimmer bits with one replaceable knife fixed by Torx screw. For specialist application requiring low down-time and economy. Pattern bit type 652B is equipped with the top bearing for use template. For routing, trimming and grooving in boards materials (laminated chipboards, worktops panels, MDF).  
For use on portable Routers.

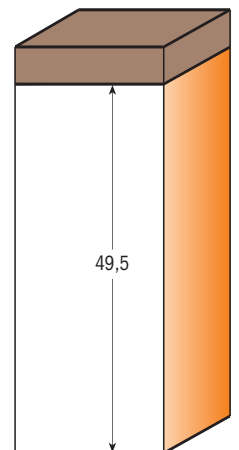

Drawings are 1:1 scale

D Cutting diameter		I Cutting length	L Overall length	Spare knives	Spare bearing	ORDER NO. Shank Ø 12mm	ORDER NO. Shank Ø 12,7mm
mm	inches	mm	mm				
19	3/4	49,5	100,3	790.495.12	791.011.00	<b>652.690.11B</b>	<b>652.691.11B</b>

**Spare parts:** **790.495.12** Knives 49,5 x 12 x 1,5      **991.061.00** Torx key T15      **541.002.00** Stop collar for Ø12,7mm  
**990.072.00** Torx screw M3,5x3,5      **791.011.00** Ø19mm bearing      **991.056.00** 1,5 mm hex key





**652**



Straight trimmer bits with one replaceable knife fixed by Torx screw. For specialist application requiring low down-time and economy. The knives 29,5x9x1,5mm give 40mm length of cut when taking a series of passes. For routing, trimming and grooving in boards materials (laminated chipboards, worktops panels, MDF). For use on portable Routers.

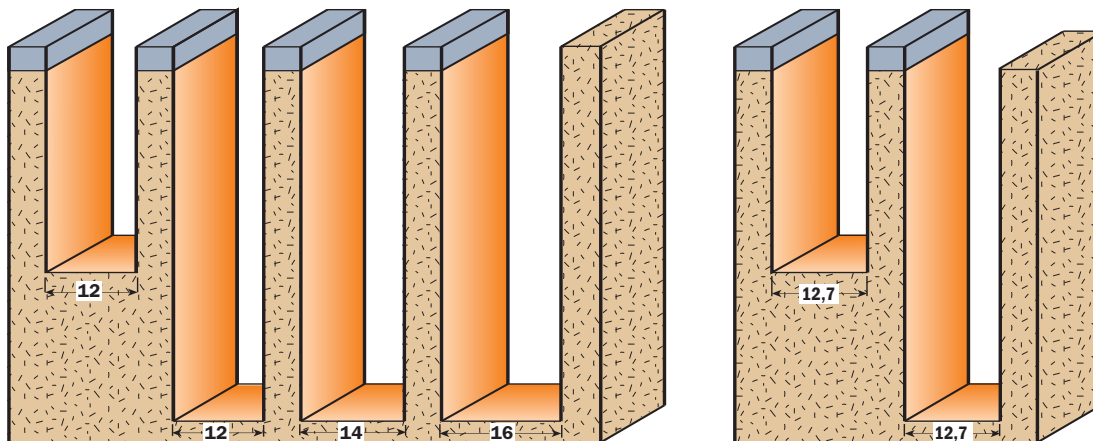

Drawings are 1:1 scale

D Cutting diameter mm inches	I Cutting length mm	L Overall length mm	Spare knives	ORDER NO. Shank Ø 8mm	ORDER NO. Shank Ø 12mm	ORDER NO. Shank Ø 12,7mm
12	29,5	79,3	790.295.09	<b>652.120.11</b>		
12,7 1/2	29,5	89,3	790.295.09			<b>652.627.11</b>
14	50	95,7	790.500.09		<b>652.141.11</b>	
16	50	95,7	790.500.09		<b>652.161.11</b>	

**Spare parts:** **790.295.09** Knives 29,5 x 9 x 1,5  
**790.500.09** Knives 50 x 9 x 1,5 (new construction with 3 bore)

**990.072.00** Torx screw M3,5x3,5  
**991.061.00** Torx key T15

**Pattern bits with knives**



**656**



Pattern bit type 656 is equipped with the bearing above the cutter for use template. For finishing, routing and grooving in boards materials (laminated chipboards, MDF) and hard wood. For use on portable Routers or CNC machining centers.

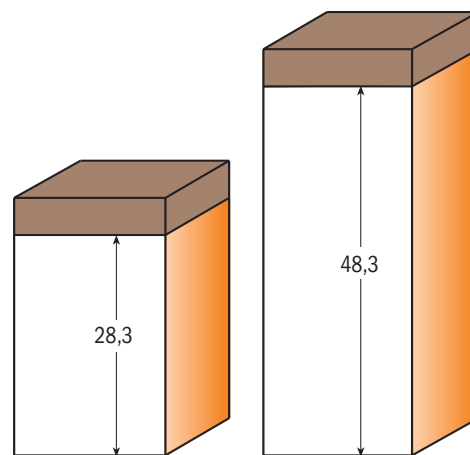

Drawings are 1:1 scale

D Cutting diameter mm inches	I Cutting length mm	L Overall length mm	Spare knives	ORDER NO. Shank Ø 8mm	ORDER NO. Shank Ø 12mm	ORDER NO. Shank Ø 12,7mm
19 3/4	28,3	68,5	790.283.12	<b>656.190.11</b>		
19 3/4	28,3	79,5	790.283.12			<b>656.691.11</b>
19 3/4	48,3	99,8	790.483.12		<b>656.692.11</b>	<b>656.693.11</b>

**Spare parts:** **790.283.12** Knives 28,3 x 12 x 1,5  
**790.483.12** Knives 48,3 x 12 x 1,5  
**990.075.00** Torx screw M4x6  
**991.061.00** Torx key T15  
**791.034.00** Ø8 - 19mm bearing

**541.004.00** Stop collar for Ø8mm  
**791.011.00** Ø19mm bearing  
**541.002.00** Stop collar for Ø12,7mm  
**991.056.00** 1,5mm hex key





654



Straight router bit with two replaceable knives fixed by special Torx screws. The blade is sharpened on the top with 3° angle for better plunging operation.



655

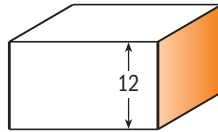

Drawings are 1:1 scale

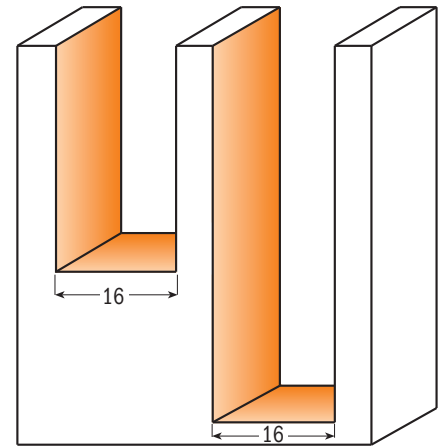

Drawings are 1:1 scale

D Cutting diameter mm inches	I Cutting length mm	L Overall length mm	Spare knives	ORDER NO. Shank Ø 8mm	ORDER NO. Shank Ø 12mm	ORDER NO. Shank Ø 12,7mm	ORDER NO. Shank Ø 20mm
16	29,5	76,3	790.295.12	<b>654.160.11</b>			
16	29,5	86,3	790.295.12		<b>654.161.11</b>	<b>654.661.11</b>	
16	49,5	104,8	790.495.12		<b>654.162.11</b>		<b>654.662.11</b>
19 3/4	12	45	790.120.00	<b>655.190.11</b>			

**Spare parts:** **790.120.00** Knives 12 x 12 x 1,5  
**790.295.12** Knives 29,5 x 12 x 1,5

**790.495.12** Knives 49,5 x 12 x 1,5  
**990.073.00** Torx screw M3,5x5

**990.075.00** Torx screw M4x6  
**991.061.00** Torx key T15

## Straight router bits with knives for laminated



653



Straight router bit with one replaceable plunging knife and one side knife fixed by special Torx screws. The body is precise balanced. For finishing and routing, plunge cutting and grooving in boards materials (laminated chipboards, MDF) and hard wood. For use on portable Routers or CNC machining centers.

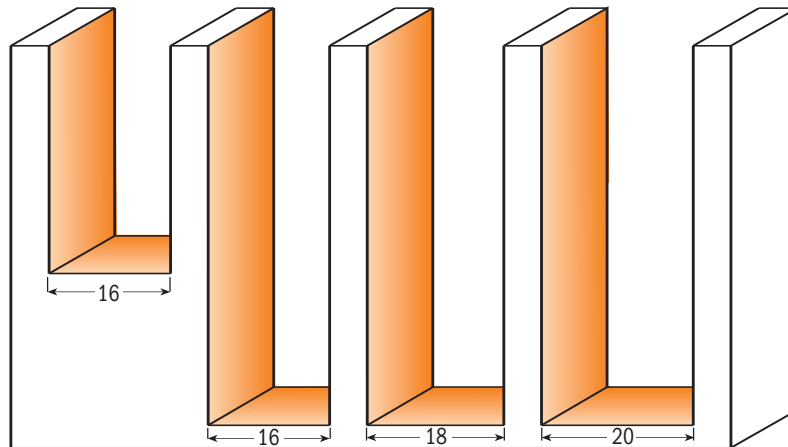

Drawings are 1:1 scale

D Cutting diameter mm	I Cutting length mm	L Overall length mm	Spare knives		ORDER NO. Shank Ø 8mm	ORDER NO. Shank Ø 12mm	ORDER NO. Shank Ø 12,7mm	ORDER NO. Shank Ø 20mm
			side	top				
15,8	28,3	91,5	790.283.12	790.075.00			<b>653.158.11</b>	
15,8	48,3	111,5	790.483.12	790.075.00			<b>653.159.11</b>	
16	28,3	81,5	790.283.12	790.075.00	<b>653.160.11</b>			
16	28,3	91,5	790.283.12	790.075.00		<b>653.161.11</b>		<b>653.661.11</b>
16	48,3	111,5	790.483.12	790.075.00		<b>653.162.11</b>		<b>653.662.11</b>
18	48,3	111,5	790.483.12	790.075.00				<b>653.681.11</b>
20	48,3	111,5	790.483.12	790.096.00				<b>653.701.11</b>

**Spare parts:** **790.075.00** Knives 7,5 x 12 x 1,5  
**790.096.00** Knives 9,6 x 12 x 1,5  
**790.283.12** Knives 28,3 x 12 x 1,5

**790.483.12** Knives 48,3 x 12 x 1,5  
**990.072.00** Torx screw M3,5x3,5  
**990.074.00** Torx screw M4x3,5

**990.075.00** Torx screw M4x6  
**991.061.00** Torx key T15



**657**



Flush trim bits with two replaceable knives fixed by special Torx screws. The blades are 2 or 4 sided sharpened and gives three extra new edges.

Guided flush trim bits type 657 are equipped with the ball bearing guides.

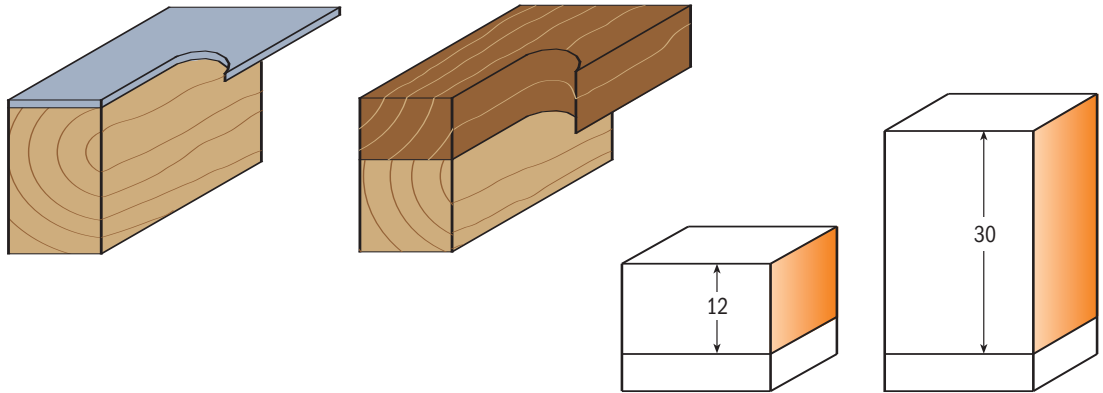

Drawings are 1:1 scale

D Cutting diameter mm inches	I Cutting length mm	L Overall length mm	Spare knives	Spare bearing	ORDER NO. Shank Ø 6,35mm	ORDER NO. Shank Ø 8mm	ORDER NO. Shank Ø 12,7mm
19 3/4	12	55	790.120.00	791.007.00	<b>657.192.11</b>	<b>657.190.11</b>	
19 3/4	30	74	790.300.00	791.007.00		<b>657.191.11</b>	
19 3/4	30	96	790.300.00	791.007.00			<b>657.692.11</b>

**Spare parts:** **790.120.00** Knives 12 x 12 x 1,5 **991.061.00** Torx key T15 **990.052.00** Torx screw TCEI M4x6  
**790.300.00** Knives 30 x 12 x 1,5 **791.007.00** Ø6 - 19mm bearing **991.062.00** 2,5mm hex key  
**990.075.00** Torx screw M4x6 **990.410.00** Shield 4.2/9 for screw M4

**Flush trim bits with knives**



**657**



Flush trim bits with two replaceable knives fixed by special Torx screws. The blades are 2 or 4 sided sharpened and gives three extra new edges.

Guided flush trim bits type 657 are equipped with the double bearing guides.

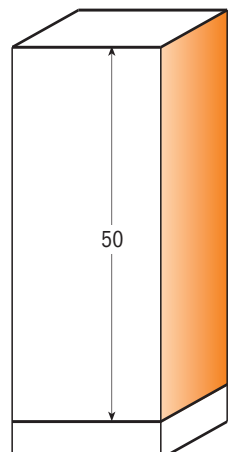
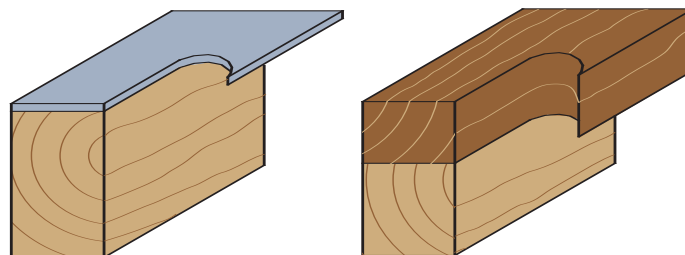

Drawings are 1:1 scale

D Cutting diameter mm inches	I Cutting length mm	L Overall length mm	Spare knives	Spare bearing	ORDER NO. Shank Ø 12mm	ORDER NO. Shank Ø 12,7mm
19 3/4	50	112	790.500.00	791.007.00	<b>657.991.11</b>	<b>657.992.11</b>

**Spare parts:** **790.500.00** Knives 50 x 12 x 1,5 **990.410.00** Shield 4.2/9 for screw M4  
**990.075.00** Torx screw M4x6 **990.052.00** Torx screw TCEI M4x6  
**991.061.00** Torx key T15 **991.062.00** 2,5mm hex key  
**791.007.00** Ø6 - 19mm bearing



Bevel and Chamfer trim bits with two replaceable knives fixed by special Torx screws. The knives are 4 sided sharpened and gives three extra new edges. Guided bevel and chamfer trim bits type 659 are equipped with the ball bearing guides. Type 658 is unguided. For specialist applications requiring economy of replaceable tips. For precision work on laminates, MDF or for quick rounded edges in hard wood. For use on portable Routers or CNC machining centers.

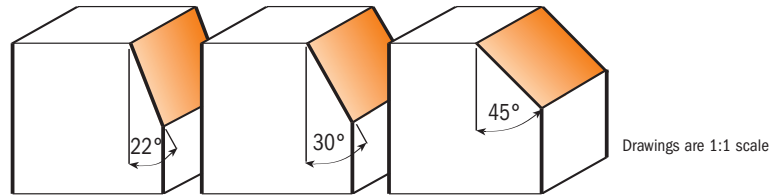

A Angolo di taglio	D Diam. di taglio mm	I Cutting length mm	L Overall length mm	Spare knives	Spare bearing	ORDER NO. Shank Ø 6,35mm	ORDER NO. Shank Ø 8mm	ORDER NO. Shank Ø 12,7mm
45°	29	12	53	790.120.00			<b>658.045.11</b>	
22°	25	12	64	790.120.00	791.006.00	<b>659.023.11</b>	<b>659.022.11</b>	
30°	28	12	65	790.120.00	791.006.00	<b>659.031.11</b>	<b>659.030.11</b>	
45°	29	12	60	790.120.00	791.022.00	<b>659.046.11</b>	<b>659.045.11</b>	
45°	29	12	70	790.120.00	791.022.00			<b>659.646.11</b>

**Spare parts:** **790.120.00** Knives 12 x 12 x 1,5  
**990.075.00** Torx screw M4x6  
**991.061.00** Torx key T15

**791.022.00** Ø5 - 13mm bearing  
**791.006.00** Ø5 - 16mm bearing  
**990.400.00** Shield 3.2/7 for screw M3

**990.051.00** Torx screw TCEI M3x6  
**991.062.00** 2,5mm hex key

# Rabbeting bits with knives



Rabbeting bits with two replaceable knives fixed by special Torx screws. The blades are 4 sided sharpened and gives high economy of your work with board materials.

Rabbeting bits are equipped with the ball bearing guides for rabbeting width H= 9,5mm. Optionals you can choose bearings for rabbeting width 12,7 - 11,1 - 8 - 6,3 - 3,2 - 0mm. For chipboards, hard wood or MDF. For use on portable Routers.

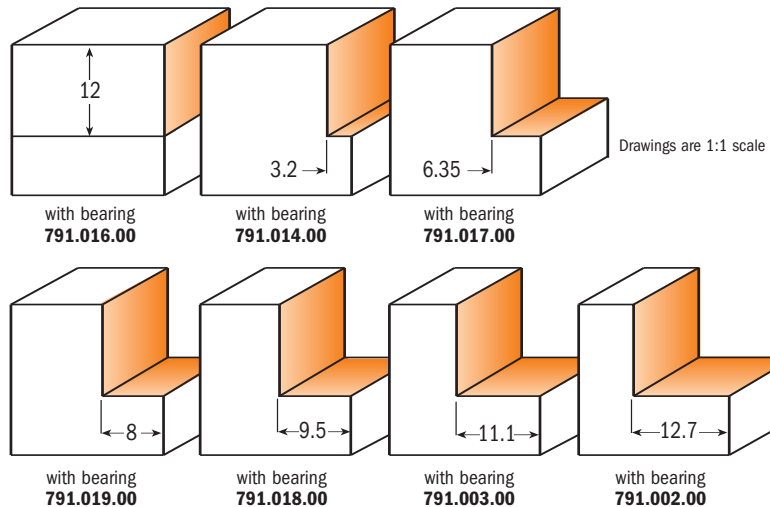

H Cutting depth mm inches	D Cutting diameter mm	I Cutting length mm	L Overall length mm	Spare knives	Spare bearing	ORDER NO. Shank Ø 6,35mm	ORDER NO. Shank Ø 8mm	ORDER NO. er Ø 12,7mm
9,5 3/8	34,9	12	53	790.120.00	791.018.00	<b>660.351.11</b>	<b>660.350.11</b>	
9,5 3/8	34,9	12	63	790.120.00	791.018.00			<b>660.851.11</b>

**Spare parts:** **790.120.00** Knives 12 x 12 x 1,5  
**990.075.00** Torx screw M4x6  
**991.061.00** Torx key T15

**990.400.00** Shield Ø3.2/Ø7 for screw M3  
**541.552.00** Shield Ø3.25/Ø15.8 for screw M3  
**990.051.00** Torx screw TCEI M3x6

**990.053.00** Torx screw TCEI M3x10  
**990.054.00** Torx screw TCEI M3x16  
**991.062.00** 2,5mm hex key



660.9



Your choice of "The Grand Rabbet" by CMT is an investment that shows your commitment to quality.

This CMT product will deliver years of reliable service under normal use. The collar sets (791.705.00-791.706.00-791.707.00) will enable you to produce 17 different rabbet sizes including rabbets for under-size plywood applications.

For rabbet sizes over 12,7mm (1/2"), make the cuts in several shallow passes until the desired depth is achieved. Available in 12 and 12,7mm shanks.

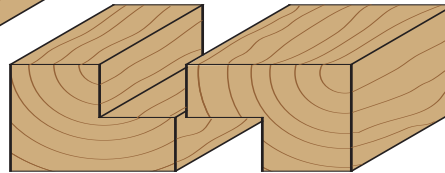
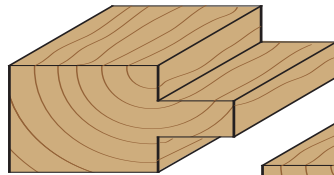

Optional

Order no. 799.517.00

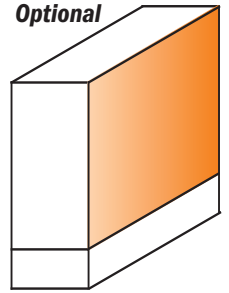

Optional

Order no. 791.705.00

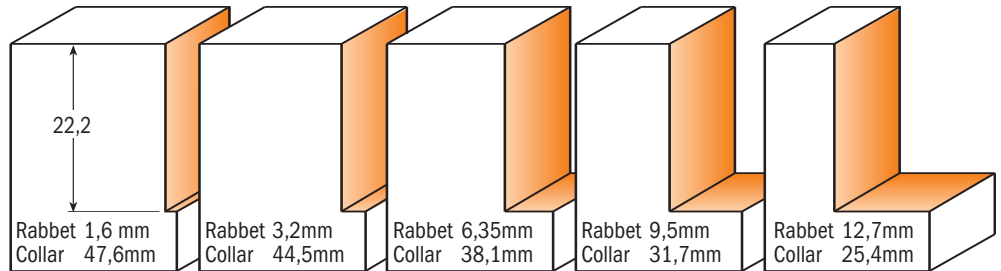

Optional

Order no. 791.706.00

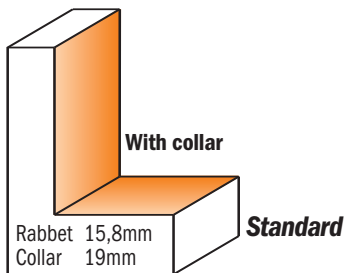
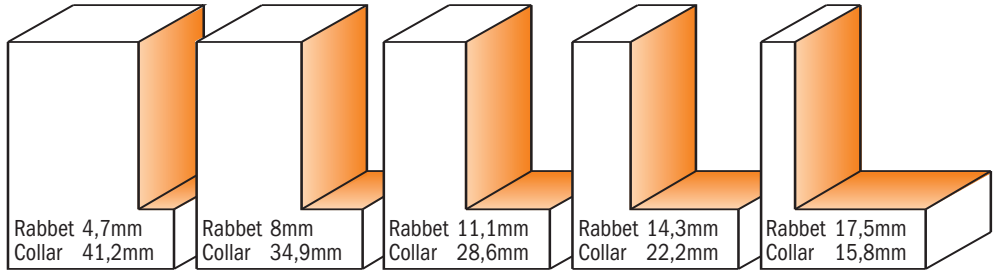

Optional

Order no. 791.707.00

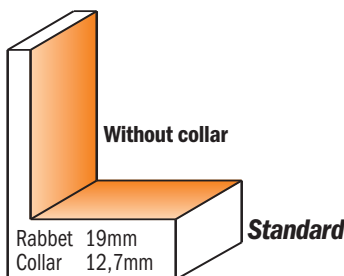
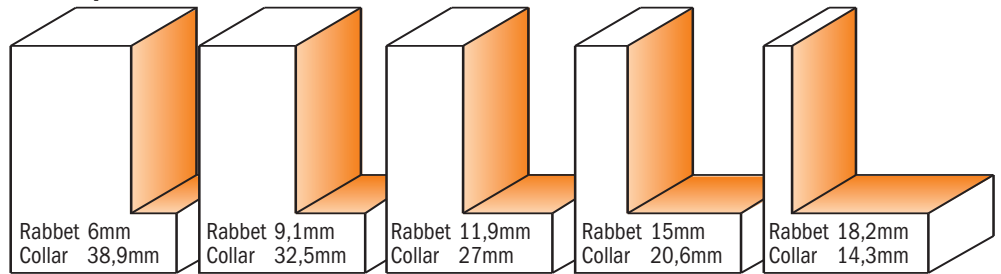

Drawings are 1:1 scale

H Cutting depth mm inches	D Cutting diameter mm	I Cutting length mm	L Overall length mm	Spare knives	Spare bearing	ORDER NO. Shank Ø 12mm	ORDER NO. Shank Ø 12,7mm
16 5/8	50,8	28,3	87,3	790.283.12	791.010.00	660.990.11	660.991.11

**Spare parts:** 790.283.12 Knives 28,3 x 12 x 1,5      791.010.00 Spare bearing Ø6,35 - 12,7mm  
 990.075.00 Torx screw M4x6      541.514.00 Stop collar for Ø6,4mm  
 991.061.00 Torx key T15      799.503.00 Bushings Ø19,05mm  
 990.410.00 Shield Ø4,2/Ø9 for screw M4  
 990.052.00 Torx screw TCEI M4x6  
 991.062.00 2,5mm hex key

**OPTIONAL:** 791.517.00 Collar for flush trim  
 791.705.00 5 pcs. collar set (1,6-3,2 - 6,35 - 9,5 - 12,7mm rabbets)  
 791.706.00 5 pcs. collar set (4,7 - 8 - 11,1 - 14,3 - 17,5mm rabbets)  
 791.707.00 5 pcs. collar set (6 - 9,1 - 11,9 - 15 - 18,2mm rabbets)





Roundover bits with two replaceable knives fixed by special Torx screws. The blades are 2 sided profiled and give high economy of your work with laminates. Roundover bits type are equipped with the ball bearing guides. For precision work on laminates. Radius R2 or R3 is for rounded 2mm or 3mm ABS edges. Radius R5 is for quick rounded edges in hard wood or MDF. For use on portable Routers.

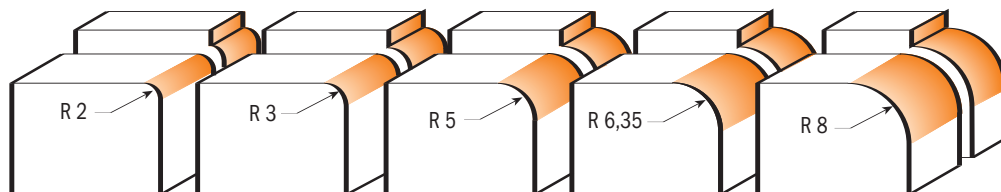

Drawings are 1:1 scale

R Raggio mm	inches	D Cutting diameter mm	I Cutting length mm	L Overall length mm	Spare knives	Spare bearing	ORDER NO. Shank Ø 6,35mm	ORDER NO. Shank Ø 8mm	ORDER NO. Shank Ø 12,7mm
2	1/16	22,8	19,5	63	790.020.00	791.007.00	<b>661.021.11</b>	<b>661.020.11</b>	
3	1/8	24,6	19,5	63	790.030.00	791.007.00	<b>661.031.11</b>	<b>661.030.11</b>	
5	3/19	28,6	19,5	63	790.050.00	791.007.00	<b>661.051.11</b>	<b>661.050.11</b>	
6,35	1/4	29	24	67	790.064.00	791.006.00	<b>661.064.11</b>	<b>661.063.11</b>	
8	5/15	32	24	67	790.080.00	791.006.00		<b>661.080.11</b>	
8	5/15	32	24	77	790.080.00	791.006.00			<b>661.581.11</b>

**Spare parts:**  
**790.020.00** Knives R2 (19,5 x 9 x 1,5)  
**790.030.00** Knives R3 (19,5 x 9 x 1,5)  
**790.050.00** Knives R5 (19,5 x 9 x 1,5)  
**790.064.00** Knives R6,35 (24 x 12 x 1,5)  
**790.080.00** Knives R8 (24 x 12 x 1,5)

**990.076.00** Torx screw M4x4 for Knives  
**991.061.00** Torx key T15  
**791.007.00** Ø6 - 19mm bearing  
**990.410.00** Shield 4.2/9 for screw M4  
**990.052.00** Torx screw TCEI M4x6

**791.006.00** Ø5 - 16mm bearing  
**990.400.00** Shield for screw M3  
**990.051.00** Torx screw TCEI M3x6  
**991.062.00** 2,5mm hex key

## Spare parts & Accessories

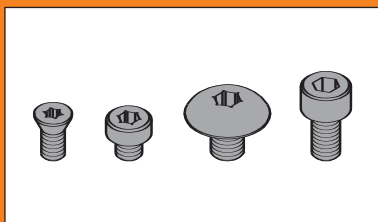

### Screw for knives and bearing

**990**

DESCRIPTION	ORDER NO.
Torx screw M2,5x5,5	<b>990.071.00</b>
Torx screw M3,5x3,5	<b>990.072.00</b>
Torx screw M3,5x5	<b>990.073.00</b>
Torx screw M4x3,5	<b>990.074.00</b>
Torx screw M4x6	<b>990.075.00</b>
Torx screw TCEI M3x6	<b>990.051.00</b>
Torx screw TCEI M4x6	<b>990.052.00</b>
Torx screw STEI M3x3 (for 541 stop collar)	<b>990.005.00</b>

### Key for knives and bearing screws

**991**

DESCRIPTION	ORDER NO.
Torx key T8	<b>991.063.00</b>
Torx key T15	<b>991.061.00</b>
2,5mm hex key	<b>991.062.00</b>
1,5mm hex key (for stop collar)	<b>991.056.00</b>



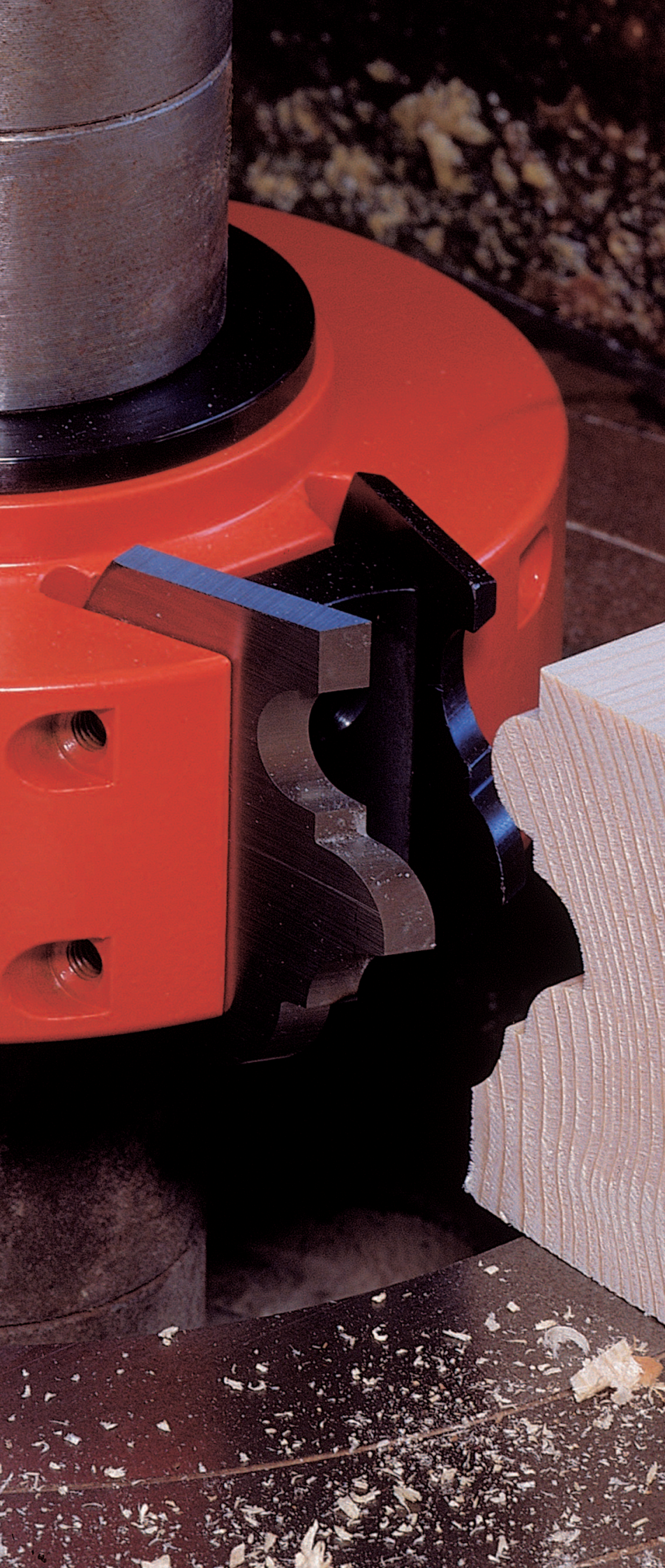

## Cutter heads & knives



Rabbeting cutter head

124



Multiradius roundover

128



Professional raised panel

134



Rabbeting cutter head

138



Multiprofile set with limitors

139



Multiprofile set without limitors

140



Knives and limitors 40-50mm 141~149

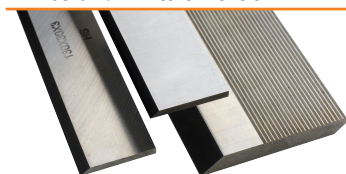

Planer and Jointer knives

151~152

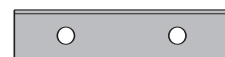

HWM Reversible knives

154~155



694.100



These cutter heads have been designed for:

- rebating from top and from bottom;
- jointing
- grooving

in your spindle moulder machines, double-end tenoner and edging machines.

Perfect in all materials, but a better result is achieved using chipboard and MDF, wood composites, plastic materials and laminates.

Improved design with shear angle.

**Technical details:**

- Hard aluminium alloy body with high resistance to tensile and yield stress
- 2 universal HWM straight knives 50x12x1,5mm [Z2]
- 4 universal HWM scoring knives 14x14x2mm [V4]
- Tools for manual feed MAN
- Pins for the automatic positioning of the knives

- Supplied in a solid plastic box

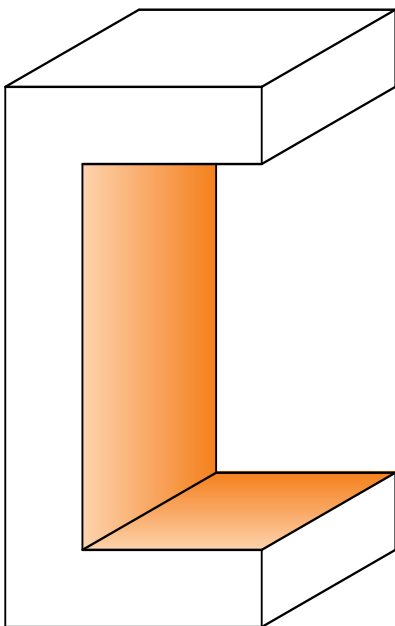

Drawings are 1:1 scale

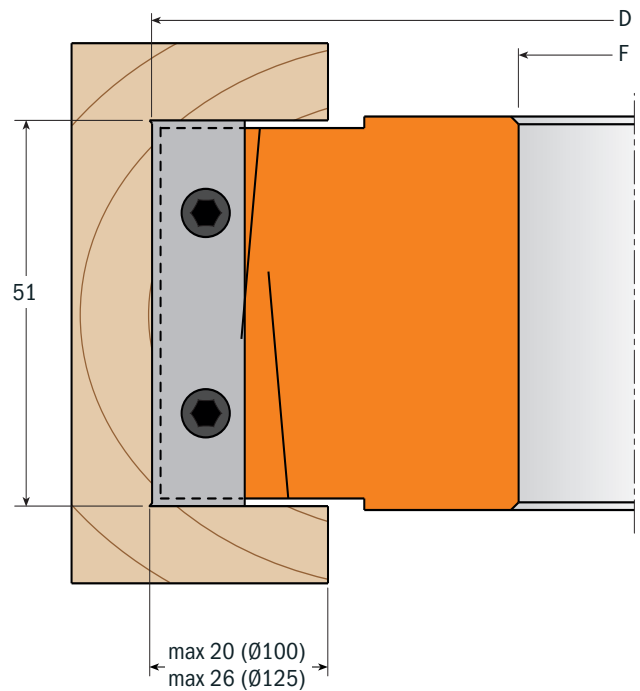

D Cutting diameter mm	F Bore diameter mm	Z No. of teeth	RPM min. - max	ORDER NO.
100	19,05	2+4	7500~12500	<b>694.100.19</b>
100	30	2+4	7500~12500	<b>694.100.30</b>
100	31,75	2+4	7500~12500	<b>694.100.31</b>
100	35	2+4	7500~12500	<b>694.100.35</b>
125	40	2+4	6100~10000	<b>694.125.40</b>
125	50	2+4	6100~10000	<b>694.125.50</b>

- Spare parts:**
- 790.500.00** HWM Knives 50x12x1,5 mm
  - 790.140.00** HWM Knives 14x14x2mm
  - 695.999.46** Wedge for knives 46x11x9,5mm
  - 990.064.00** Screw M8x16
  - 990.080.00** Screw Torx M5x6,5

**694.001**



These cutter heads are the ideal tools to create precision slots and grooves in materials from 4 to 15mm in depth by using the CMT 3 piece adjustable grooving set. This set includes:

- 2 cutter heads type (A) Z4 + V4
- 1 cutter head type (B) Z2
- 12 spacer rings from 0,1 to 2mm

To be used in your spindle moulder machines, double-end tenoners and shapers machines.

Perfect grooving in all materials, but ideal on solid woods, plywood and laminated panels.

**Technical details:**

- Super-strength steel body
- 2 HWM Knives 7,65x12x1,5mm [Z2]
- 4 HWM Knives 18x18x1,5mm [Z4]
- 4 HWM Knives 14x14x1,2mm [V4]

- Tools for manual feed MAN
- Pins for the automatic positioning of the knives
- **Supplied in a solid plastic box**

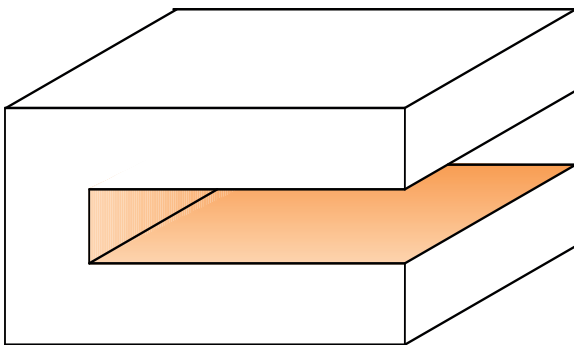
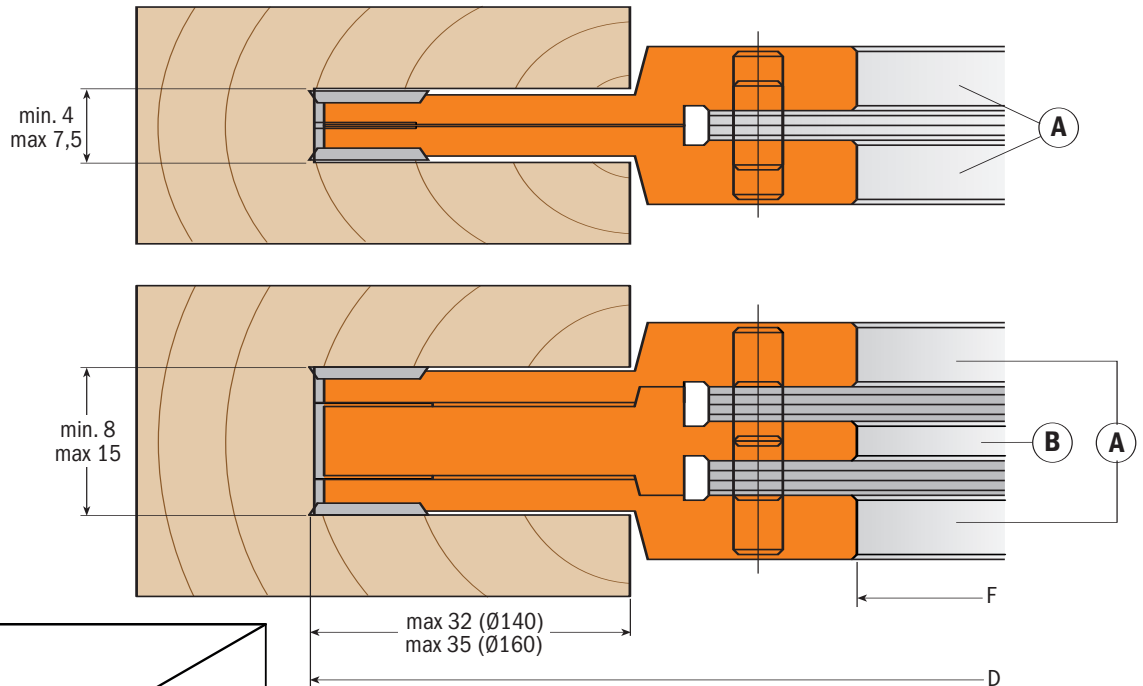

Drawings are 1:1 scale

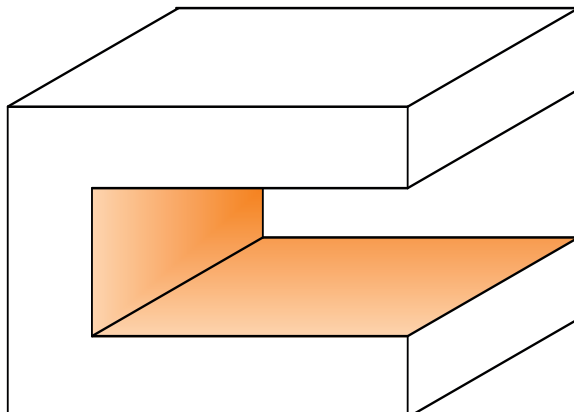

D Cutting diameter mm	F Bore diameter mm	Z No. of teeth	RPM min. - max	ORDER NO. Steel body
140	30	4+4	5500~9500	<b>694.001.30</b>
140	31,75	4+4	5500~9500	<b>694.001.31</b>
140	35	4+4	5500~9500	<b>694.001.35</b>
160	40	4+4	4800~8300	<b>694.001.40</b>
160	50	4+4	4800~8300	<b>694.001.50</b>

**Spare parts:**

**For cutter heads (A)**

- 790.181.00** HWM Knives 18x18x1,95mm
- 990.079.00** Screw Torx M4x3,2
- 695.996.02** Threaded ring M4 (Ø12x1,7mm)
- S790.140.10** HWM Knives 14x14x1,2mm
- 695.996.01** Threaded ring M4 (Ø10x1,6mm)

**For cutter heads (B)**

- 790.076.00** HWM Knives 7,65x12x1,5mm
- 695.999.07** Wedge for knives 7x11x9,5mm
- 990.063.00** Screw M5x18



694.002



CMT Chamfer cutter heads cut clean, accurate bevels, chamfers and joints that are great for edge work. To be used in your spindle moulder machines, double-end tenoners and shapers machines. Perfect in all materials, but ideal on solid woods, panel materials veneered and plastic coated.

**Technical details:**

- Hard aluminium alloy body with high resistance to tensile and yield stress
- 2 HWM Knives 50x12x1,5mm [Z2]
- Tools for manual feed MAN
- Pins for the automatic positioning of the knives

**Supplied in a solid plastic box**

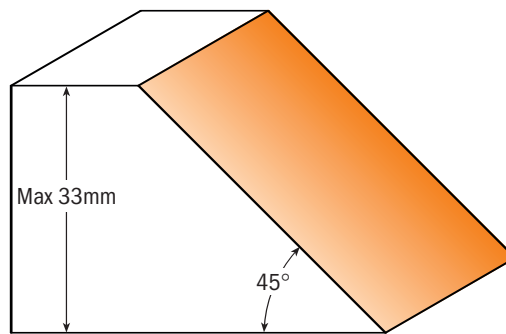
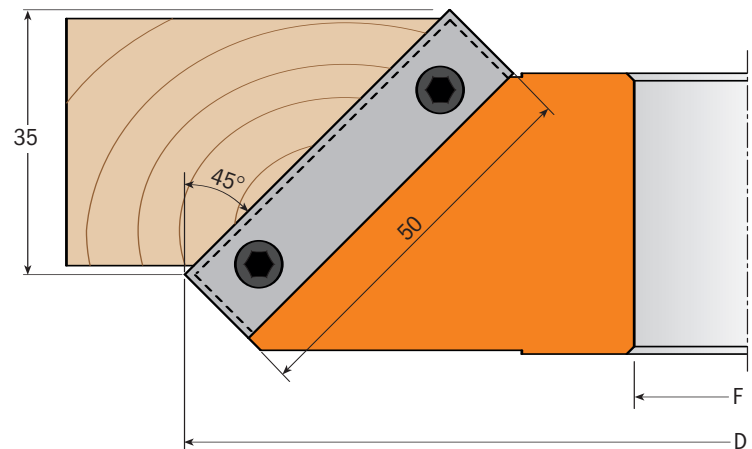
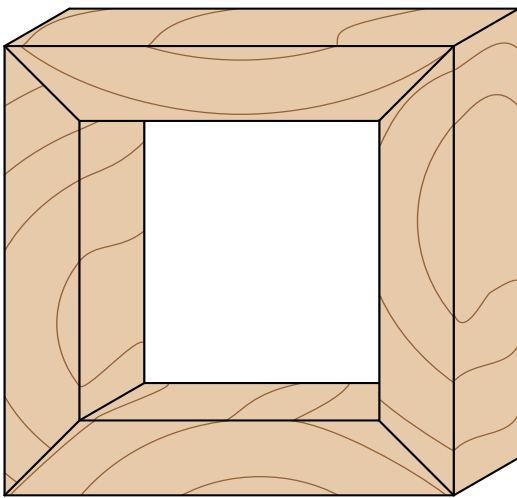

Drawings are 1:1 scale

D Cutting diameter mm	F Bore diameter mm	Z No. of teeth	RPM min. - max	ORDER NO.
150	30	2	5100~8800	<b>694.002.30</b>
150	31,75	2	5100~8800	<b>694.002.31</b>
150	35	2	5100~8800	<b>694.002.35</b>
150	40	2	5100~8800	<b>694.002.40</b>
160	50	2	4800~8300	<b>694.002.50</b>

**Spare parts:** **790.500.00** HWM Knives 50x12x1,5  
**695.999.41** Wedge for knives 41x11x9,5mm  
**990.086.00** Screw M8x20

**694.005**



Innovative design for simply assembly and use with enormous possibilities. In fact the CMT adjustable rounding and chamfering set is made by two pieces which are very easy to set up in your spindle moulder machine allowing you to profile in solid wood and man-made boards (with or without coating). It support five different knives that enable you to roundover both top and bottom edges in just one pass with radius 2, 3, 4, 5 and 6 mm and 45° chamfering in a wide range of stock thickness, from 18mm to 50mm. The improved design with shear angle guarantees a perfect finishing! To be used in your spindle moulder machines, double-end tenoners



**Technical details:**

- Hard aluminium alloy body with high resistance to tensile and yield stress
- One Pair of HWM Top Knives radius 4mm and 45° chamfer (20x20,5x2mm) [Z2]
- One Pair of HWM Bottom Knives radius 4mm and 45° chamfer (20x20,5x2mm) [Z2]
- Two HWM Knives 50x12x1,5mm
- Set of 21 spacer rings from 0,1 to 3mm
- Tools for manual feed MAN
- Pins for the automatic positioning of the knives

**Supplied in a solid plastic box**

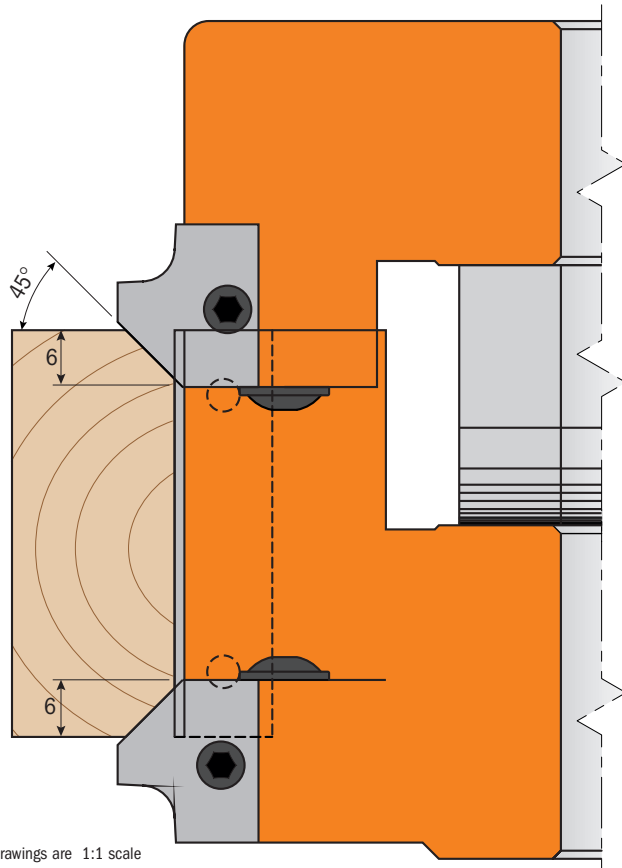
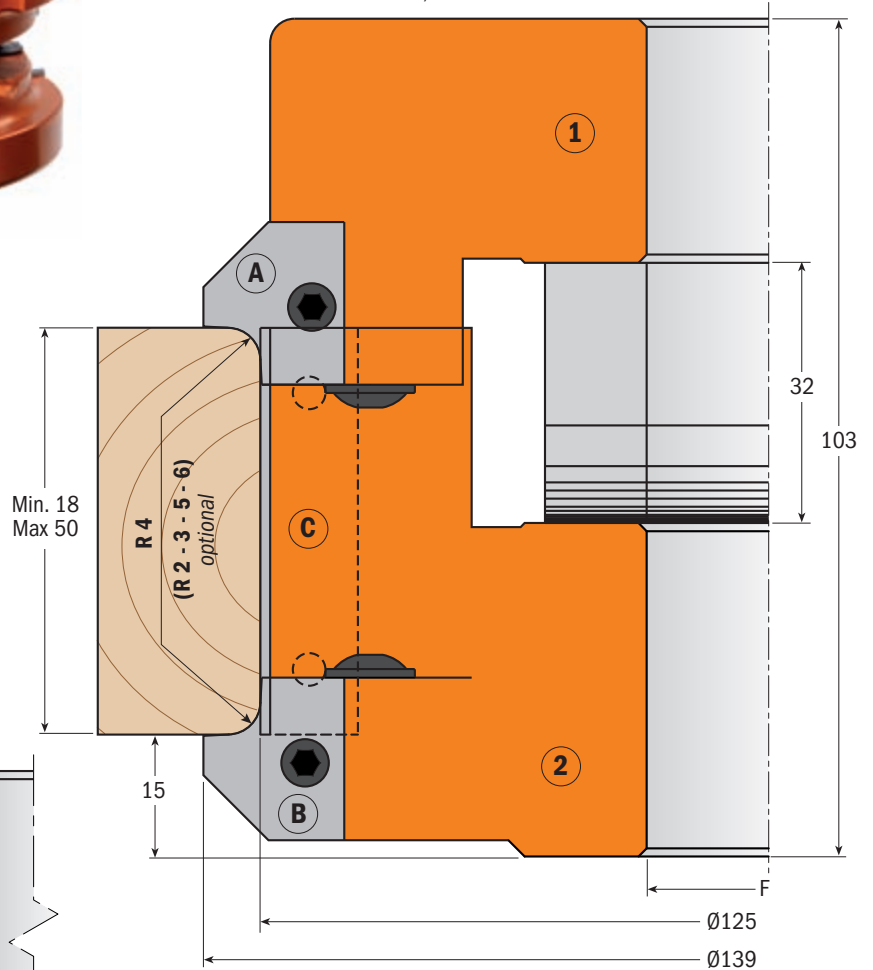

Drawings are 1:1 scale

D Cutting diameter mm	F Bore diameter mm	Z No. of teeth	RPM min. - max	ORDER NO.
139	30	2+2	5500~9400	<b>694.005.30</b>
139	31,75	2+2	5500~9400	<b>694.005.31</b>
139	35	2+2	5500~9400	<b>694.005.35</b>
139	40	2+2	5500~9400	<b>694.005.40</b>
139	50	2+2	5500~9400	<b>694.005.50</b>

**Spare parts:**

- 695.005.A2** Pair of knives for roundover/chamfer (top) R=2+45°
- 695.005.A3** Pair of knives for roundover/chamfer (top) R=3+45°
- 695.005.A4** Pair of knives for roundover/chamfer (top) R=4+45°
- 695.005.A5** Pair of knives for roundover/chamfer (top) R=5+45°
- 695.005.A6** Pair of knives for roundover/chamfer (top) R=6+45°
- 695.005.B2** Pair of knives for roundover/chamfer (bottom) R=2+45°
- 695.005.B3** Pair of knives for roundover/chamfer (bottom) R=3+45°
- 695.005.B4** Pair of knives for roundover/chamfer (bottom) R=4+45°
- 695.005.B5** Pair of knives for roundover/chamfer (bottom) R=5+45°
- 695.005.B6** Pair of knives for roundover/chamfer (bottom) R=6+45°
- 695.999.17** Wedge for knives 17x11x9,5mm
- 990.086.00** Screw M8x20
- 790.500.00** Knives 50x12x1,5mm
- 695.999.46** Wedge for knives 46x11x9,5mm
- 990.086.00** Screw M8x20

694.003



Innovative cutter heads supporting three different knives making six radius roundover profiles.

The standard cutter heads is delivered with knives radius 5 and 10 mm; two more knives sets are available to make radius 4-8mm and 3-6mm.

To be used in your spindle moulder machines, double-end tenoners and shapers machines.

Perfect in all materials, but ideal on solid woods and panel materials.

**Technical details:**

- Hard aluminium alloy body with high resistance to tensile and yield stress
- 2 HWM Knives Radius 5/10mm (25x24,8x2mm) [Z2]
- Tools for manual feed MAN
- Pins for the automatic positioning of the knives

Supplied in a solid plastic box

STANDARD

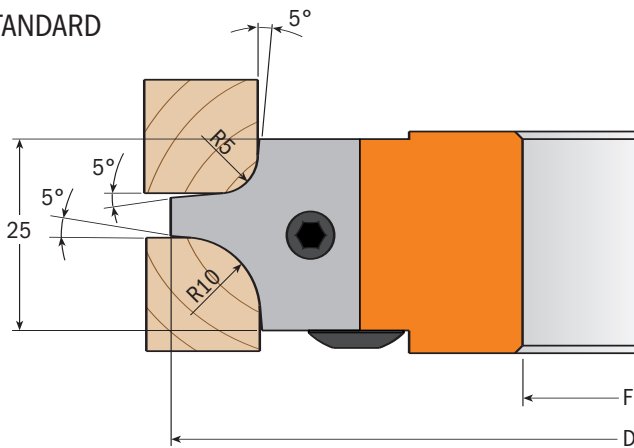

OPTIONAL

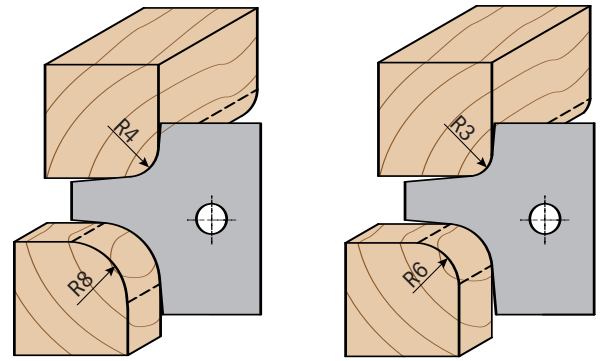

Drawings are 1:1 scale

D Cutting diameter mm	F Bore diameter mm	Z No. of teeth	RPM min. - max	ORDER NO.
113	30	2	6700~11000	<b>694.003.30</b>
113	31,75	2	6700~11000	<b>694.003.31</b>
113	35	2	6700~11000	<b>694.003.35</b>
128	40	2	5900~9700	<b>694.003.40</b>
128	50	2	5900~9700	<b>694.003.50</b>

- Spare parts:**
- 695.003.05** Pair of profiled knives R=5/10mm (25x24,8x2mm)
  - 695.003.04** Pair of profiled knives R=4/8mm (25x24,8x2mm)
  - 695.003.03** Pair of profiled knives R=3/6mm (25x24,8x2mm)
  - 695.999.22** Wedge for knives 22x11x9,5mm
  - 990.086.00** Screw M8x20

**694.004**



Innovative cutter heads supporting two different knives making four radius roundover profiles.

The standard cutter head is delivered with knives radius 15 and 20 mm; one more knives set is available to make radius 12-18mm.

To be used in your spindle moulder machines, double-end tenoners and shapers machines.

Perfect in all materials, but ideal on solid woods and panel materials.

**Technical details:**

- Hard aluminium alloy body with high resistance to tensile and yield stress
- 2 HWM Knives Radius 15/20mm (45x34,5x2mm) [Z2]
- Tools for manual feed MAN
- Pins for the automatic positioning of the knives

**Supplied in a solid plastic box**

STANDARD

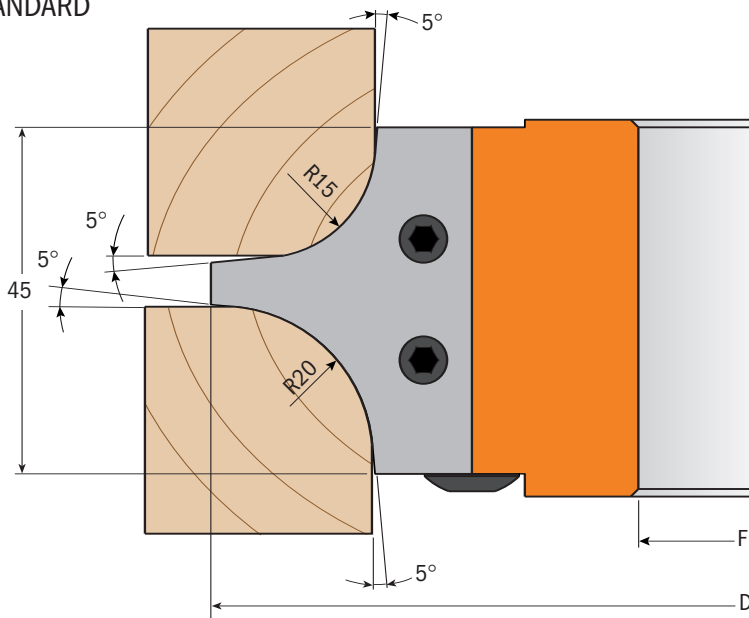

OPTIONAL

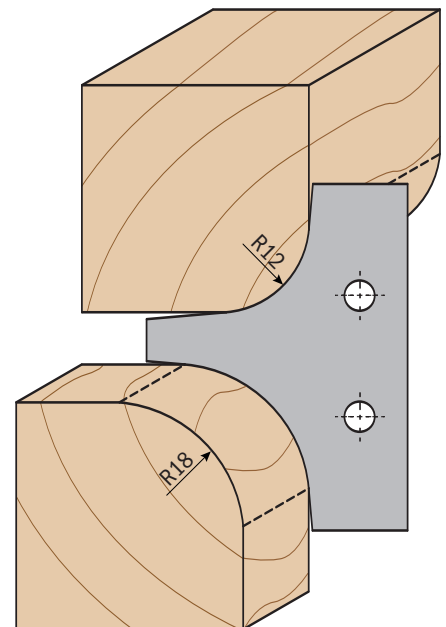

Drawings are 1:1 scale

D Cutting diameter mm	F Bore diameter mm	Z No. of teeth	RPM min. - max	ORDER NO.
132	30	2	5700~9500	<b>694.004.30</b>
132	31,75	2	5700~9500	<b>694.004.31</b>
132	35	2	5700~9500	<b>694.004.35</b>
147	40	2	5100~8500	<b>694.004.40</b>
147	50	2	5100~8500	<b>694.004.50</b>

- Spare parts:**
- 695.004.15** Pair of profiled knives R=15/20mm (45x34,5x2mm)
  - 695.004.12** Pair of profiled knives R=12/18mm (45x34,5x2mm)
  - 695.999.42** Wedge for knives 42x11x9,5mm
  - 990.086.00** Screw M8x20



694.007



This cutter head is the perfect tool to make furniture, doors, and drawer fronts that go from simple to elegant by giving them a final touch with a CMT cove bit. Use together with roundover profile and construct perfectly fitting rule joints that are ideal for drop leaf counter and table tops.

It supports three different knives making roundover and cove profiles radius 10, 12 and 15mm.

To be used in your spindle moulder machines, double-end tenoners and shapers machines.

Perfect in all materials, but ideal on solid woods and panel materials.



**Technical details:**

- Hard aluminium alloy body with high resistance to tensile and yield stress
- 2 HWM Knives Radius 10mm (34,8x29,3x2mm) [Z2]
- Tools for manual feed MAN
- Pins for the automatic positioning of the knives

Supplied in a solid plastic box

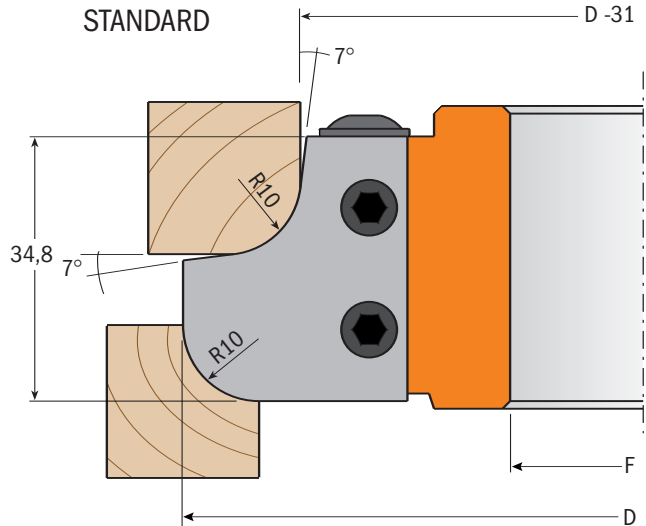

OPTIONAL

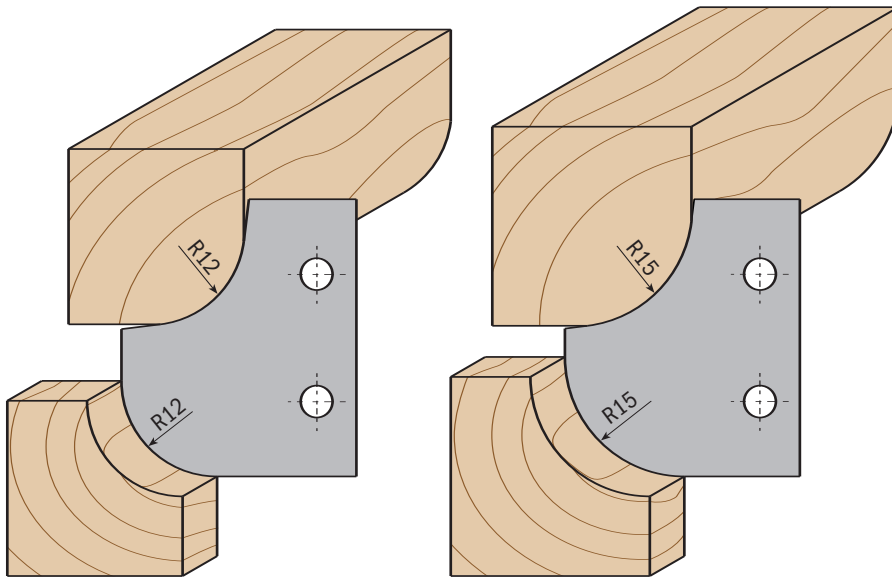

D Cutting diameter mm	F Bore diameter mm	Z No. of teeth	RPM min. - max	ORDER NO.
121	30	2	6300~10500	<b>694.007.30</b>
121	31,75	2	6300~10500	<b>694.007.31</b>
121	35	2	6300~10500	<b>694.007.35</b>
136	40	2	5600~9300	<b>694.007.40</b>
136	50	2	5600~9300	<b>694.007.50</b>

- Spare parts:**
- 695.007.10** Pair of knives roundover/cove R=10mm (34,8x29,3x2mm)
  - 695.007.12** Pair of knives roundover/cove R=12mm (34,8x29,3x2mm)
  - 695.007.15** Pair of knives roundover/cove R=15mm (34,8x29,3x2mm)
  - 695.999.31** Wedge for knives 31x11x9,5mm
  - 990.086.00** Screw M8x20mm

**694.008**



The professional CMT finger joint cutter head lets you make one of the most incredibly strong side-to-side joints in all wood and wood composites.

The tightness of the accurately cut joint and the maximum glue surface create a joint that is actually stronger than an unworked piece of wood, in stock with max thickness of 47mm. Ideal for molding manufacturers and furniture makers.

To be used in your spindle moulder machines, double-end tenoners and shapers machines.

Perfect in all materials, but ideal on solid woods and panel materials.

**Technical details:**

- Hard aluminium alloy body with high resistance to tensile and yield stress
- 2 HWM Knives 49,6x11,9x1,5mm [Z2]
- Tools for manual feed MAN
- Pins for the automatic positioning of the knives

**Supplied in a solid plastic box**

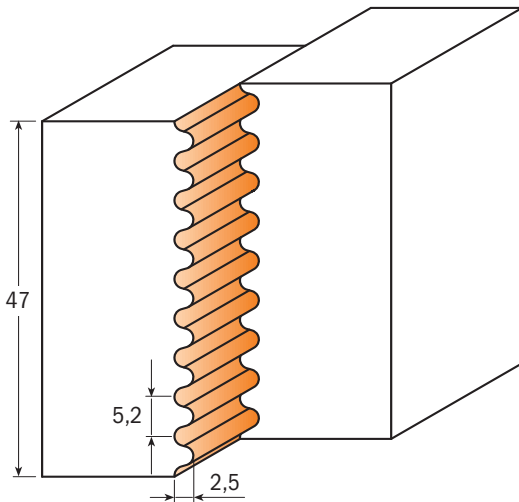

Drawings are 1:1 scale

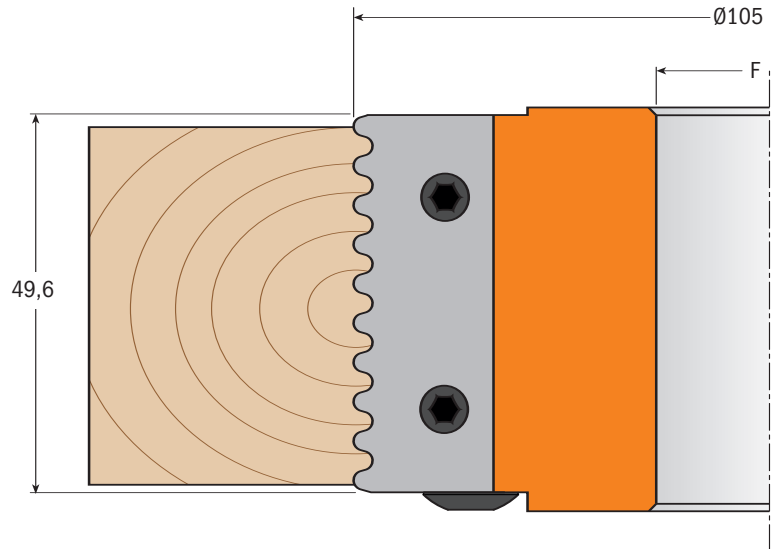

D Cutting diameter mm	F Bore diameter mm	Z No. of teeth	RPM min. - max	ORDER NO.
105	30	2	7300~11500	<b>694.008.30</b>
105	31,75	2	7300~11500	<b>694.008.31</b>
105	35	2	7300~11500	<b>694.008.35</b>
105	40	2	7300~11500	<b>694.008.40</b>
105	50	2	7300~11500	<b>694.008.50</b>

- Spare parts:**
- 695.008.01** Pair of knives for finger joint 49,6x11,9x1,5mm
  - 695.999.49** Wedge for knives 49x11x9,5mm
  - 990.066.00** Screw M6x16

694.009



The most unique and important feature of this CMT cutter head is its capacity to produce an almost indestructible glue joint quickly and without error. Ideal for shaping wide dimension panels, doors and furniture pieces. By accurately centering the cutter head to the wood, the upper and lower vertical cutting edges will cut equal proportions. Simply run one edge of the panel, turn the panel over, and then run the opposite edge - you will produce perfectly harmonized reverse cuts that match up to make flawless joints. To be used in your spindle moulder and shaper machines. Perfect in all materials, but ideal on solid woods and panel materials.

**Technical details:**

- Hard aluminium alloy body with high resistance to tensile and yield stress
- 2 HWM Knives 40x18x2mm [Z2]
- Tools for manual feed MAN
- Pins for the automatic positioning of the knives

**Supplied in a solid plastic box**

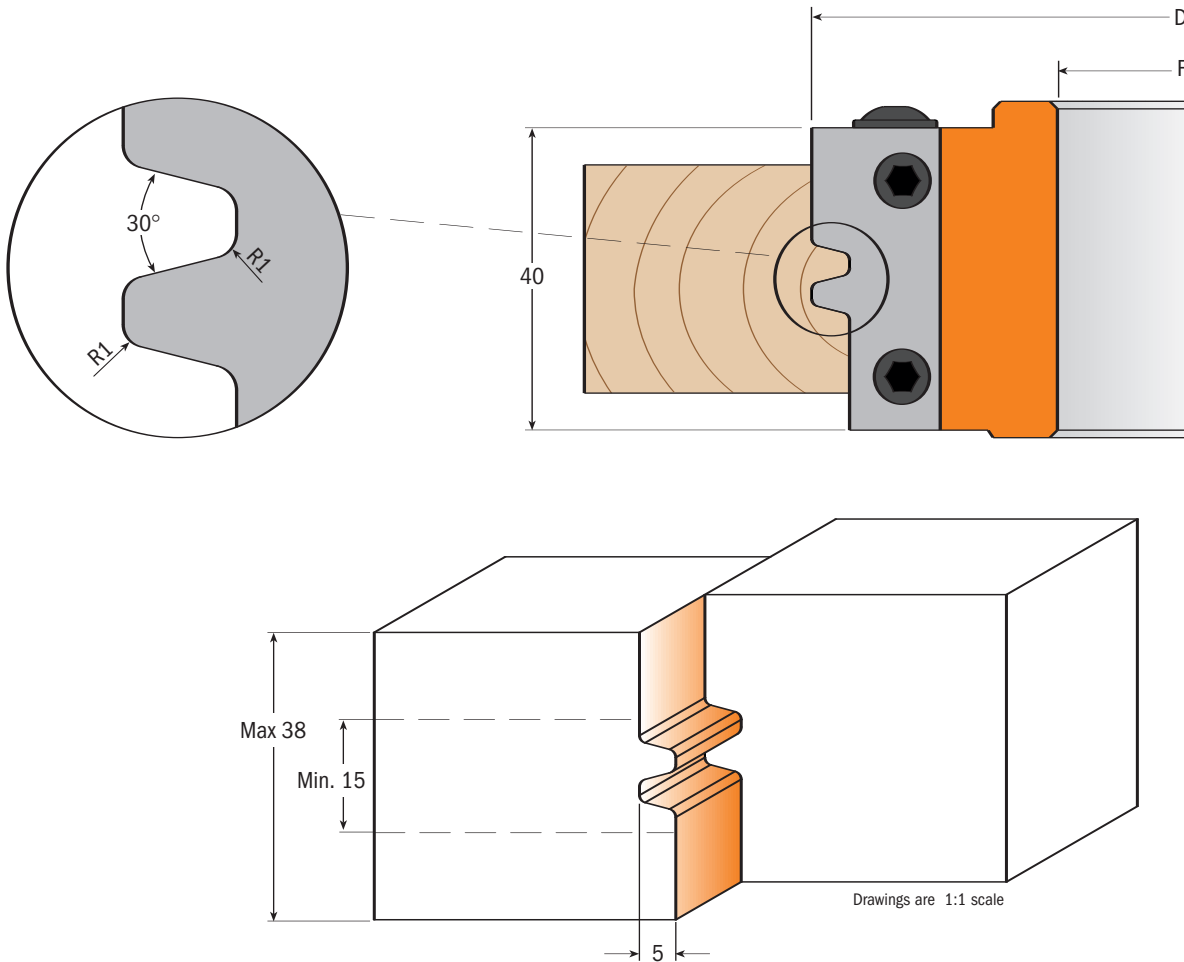

D Cutting diameter mm	F Bore diameter mm	Z No. of teeth	RPM min. - max	ORDER NO.
100	30	2	7500~12500	<b>694.009.30</b>
100	31,75	2	7500~12500	<b>694.009.31</b>
100	35	2	7500~12500	<b>694.009.35</b>
120	40	2	6400~10500	<b>694.009.40</b>
120	50	2	6400~10500	<b>694.009.50</b>

**Spare parts:**  
**695.009.01** Pair of knives for glue joint 40x18x2mm  
**695.999.38** Wedge for knives 38x11x9,5  
**990.086.00** Screw M8x20

**694.011**



CMT lock miter cutter heads bits are ideal for milling miter joints in max 29mm stock. The quick and easy way to accurately create boxes, stretcher bars, frames and any assortment of right angle or parallel joint projects.

To produce perfectly fitting 45° miter joints in two steps: first with the workpiece in horizontal position and then with the workpiece in vertical position.

To mill sturdy parallel glue joints in two steps: first with the workpiece in horizontal position with the inside face-down and then with the inside face-up. To be used in your spindle moulder and shaper machines. Perfect in all materials, but ideal on solid woods and panel materials.

**Technical details:**

- Hard aluminium alloy body with high resistance to tensile and yield stress
- 2 HWM Knives 43x23x2mm [Z2]
- Tools for manual feed MAN
- Pins for the automatic positioning of the knives

**Supplied in a solid plastic box**

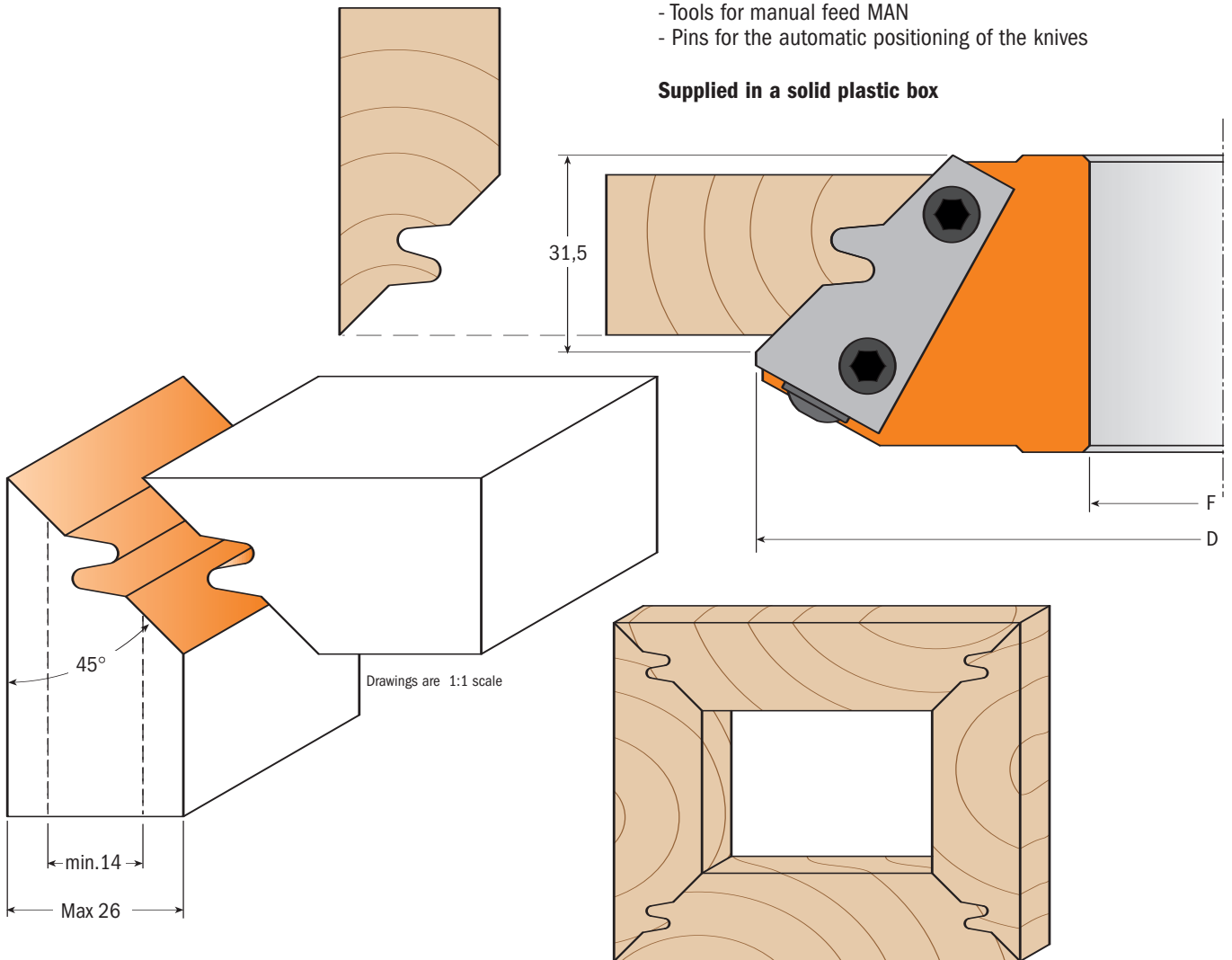

D Cutting diameter mm	F Bore diameter mm	Z No. of teeth	RPM min. - max	ORDER NO.
140	30	2	5500~9500	<b>694.011.30</b>
140	31,75	2	5500~9500	<b>694.011.31</b>
140	35	2	5500~9500	<b>694.011.35</b>
140	40	2	5500~9500	<b>694.011.40</b>
150	50	2	5100~8800	<b>694.011.50</b>

**Spare parts:** **695.011.01** Pair of knives for lock miter 43x23x2mm  
**695.999.42** Wedge for knives 42x11x9,5mm  
**990.086.00** Screw M8x20



694.013



We offer you the traditional approach to panel construction with the CMT raised panel cutter head. Make your classic raised panels on furniture, interior and cabinet doors in solid wood and wooden boards, obtaining three different profiles adjusting the cutting depth.

Multiple passes are recommended to safely and accurately obtain the perfect finishing. To be used in your spindle moulders. Perfect in all materials, but ideal on solid woods and panel materials.

**Technical details:**

- Hard aluminium alloy body with high resistance to tensile and yield stress
- 2 HWM Knives type (A) 19,8x11,9x1,5mm [Z2]
- 2 HWM Knives type (B) 60x11,9x1,5mm [Z2]
- Tools for manual feed MAN
- Pins for the automatic positioning of the knives

**Supplied in a solid plastic box**

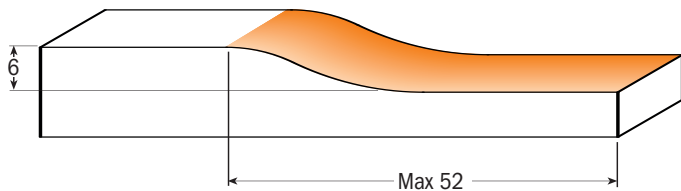
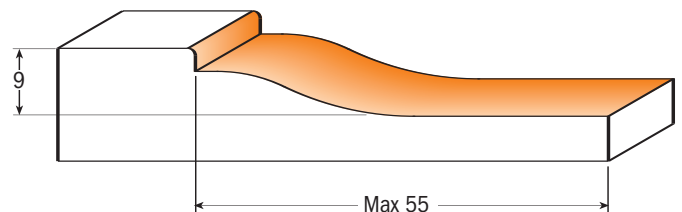
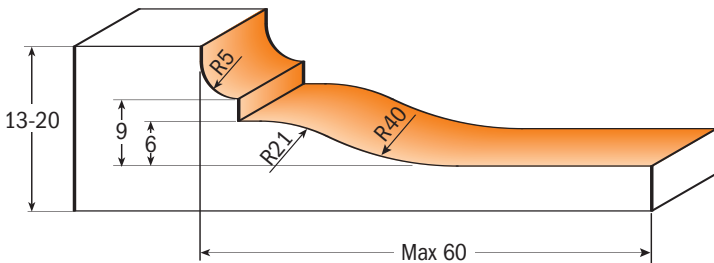
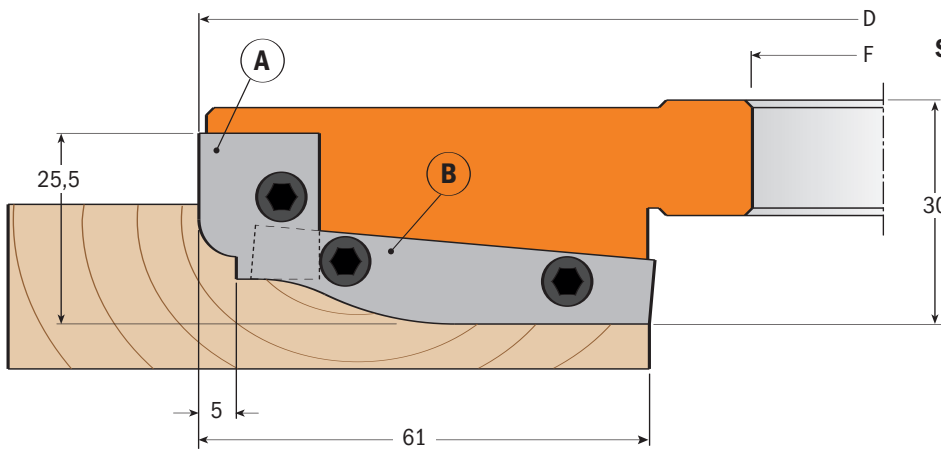

Drawings are 1:1 scale

D Cutting diameter mm	F Bore diameter mm	Z No. of teeth	RPM min. - max	ORDER NO.
183	30	2+2	4100~7000	<b>694.013.30</b>
183	31,75	2+2	4100~7000	<b>694.013.31</b>
183	35	2+2	4100~7000	<b>694.013.35</b>
200	40	2+2	3800~6400	<b>694.013.40</b>
200	50	2+2	3800~6400	<b>694.013.50</b>

- Spare parts:**
- 695.013.A1** Pair of knives type (A) 19,8x11,9x1,5mm
  - 695.013.A2** Pair of knives type (B) 60x11,9x1,5mm
  - 695.999.16** Wedge for knives type (A) 16x11x9,5mm
  - 695.999.53** Wedge for knives type (B) 53x11x9,5mm
  - 990.085.00** Screw M6x25

**694.014**



This cutter head represents the union of two cutters in one tool and it is the ideal toolheads for the construction of furniture doors and drawers. By simply adjusting the height of the head, you can cut two perfectly joining profiles with no wasted time or effort moving the fence or changing the tool. Save money by investing in a single CMT cutter head and a more efficient production. To be used in your spindle moulders. Perfect for solid woods and panel materials in min. 22mm - max 25mm stock.

**Technical details:**

- Hard aluminium alloy body with high resistance to tensile and yield stress
- 2 HWM Knives type (A) 40x24,5x2mm [Z2]
- Tools for manual feed MAN
- Pins for the automatic positioning of the knives

**Supplied in a solid plastic box**

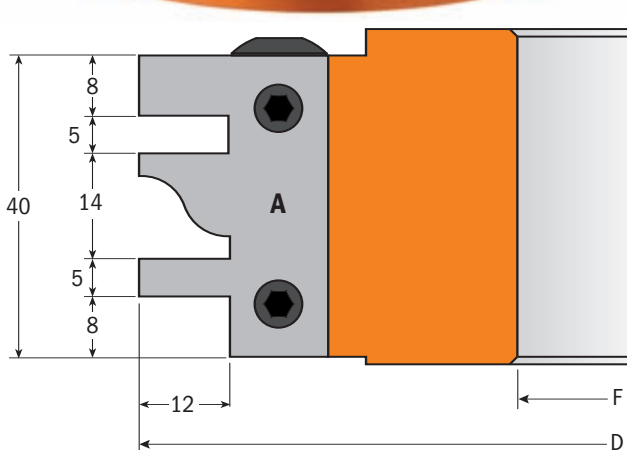
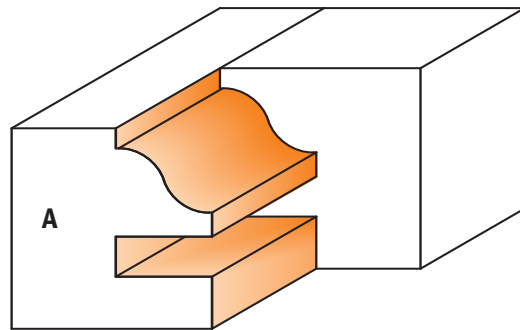

**OPTIONAL**

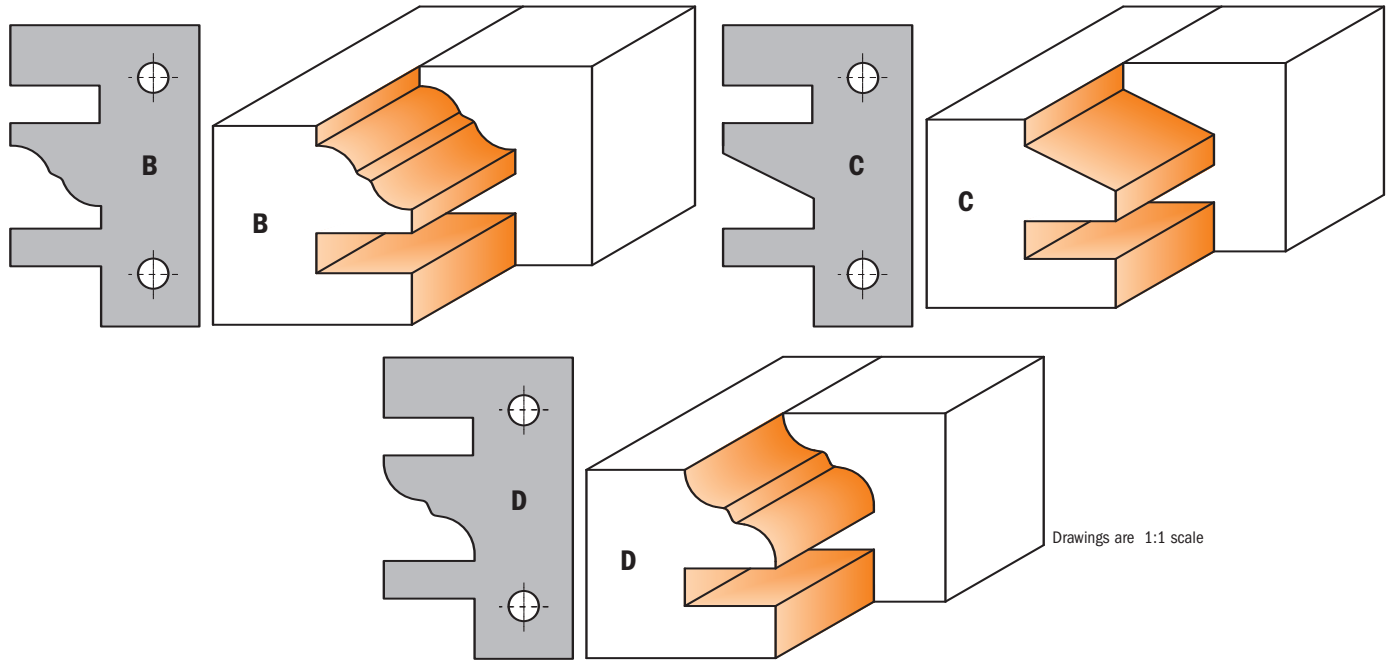

Drawings are 1:1 scale

D Cutting diameter mm	F Bore diameter mm	Z No. of teeth	RPM min. - max	ORDER NO.
120	30	2	6400~10500	<b>694.014.30</b>
120	31,75	2	6400~10500	<b>694.014.31</b>
120	35	2	6400~10500	<b>694.014.35</b>
120	40	2	6400~10500	<b>694.014.40</b>
130	50	2	5900~9700	<b>694.014.50</b>

- Spare parts:**
- 695.014A** Pair of knives type (A) 40x24,5x2mm
  - 695.014B** Pair of knives type (B) 40x24,5x2mm
  - 695.014C** Pair of knives type (C) 40x24,5x2mm
  - 695.014D** Pair of knives type (D) 40x24,5x2mm
  - 695.999.39** Wedge for knives 39x11x9,5mm
  - 990.085.00** Screw M6x25

694.015



The set has been designed to produce furniture and room doors in soft and hard wood. It offers the versatility to mount five different knives producing the most popular classical profiles.

The adjustable groover included in the set can also be used individually for carrying out 8 to 15mm thick adjustable grooves. To be used in your spindle moulders.

Perfect for solid woods and panel materials in max 48mm stock.

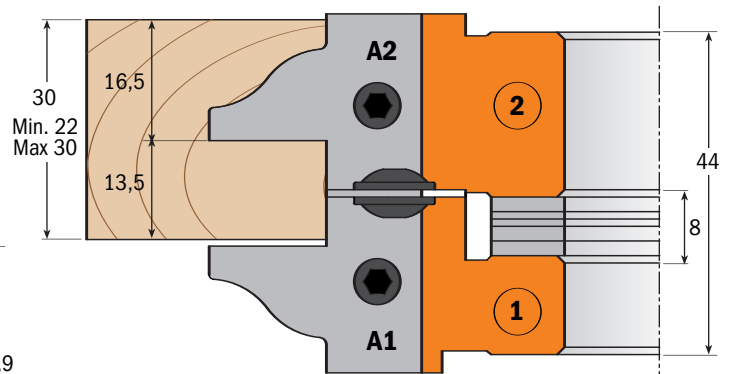
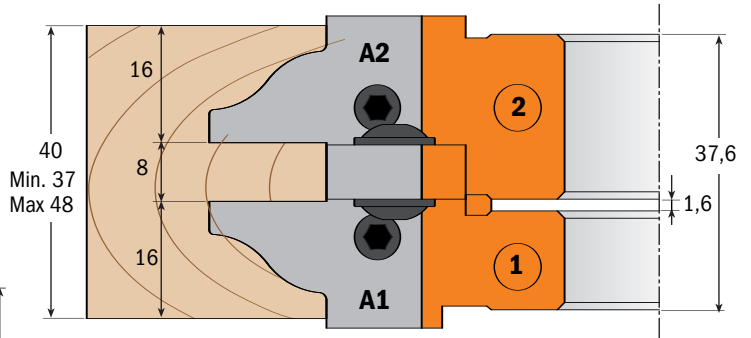
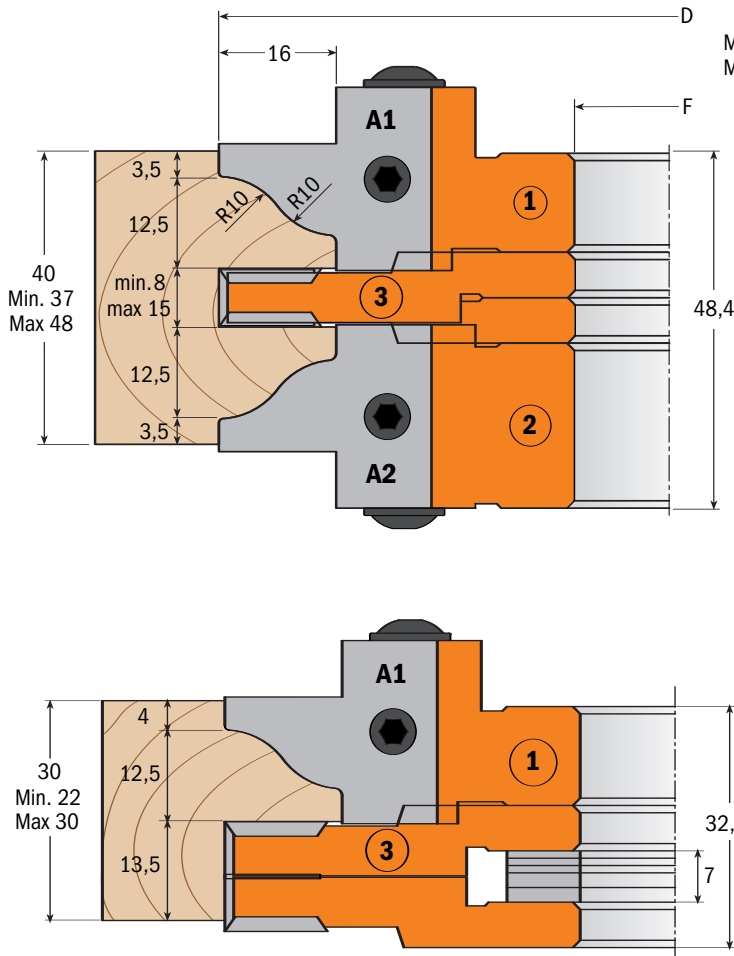

D Cutting diameter mm	F Bore diameter mm	Z+V No. of teeth	RPM min. - max	ORDER NO.
132	30	2+2	5700~9500	<b>694.015.30</b>
132	31,75	2+2	5700~9500	<b>694.015.31</b>
132	35	2+2	5700~9500	<b>694.015.35</b>
147	40	2+2	5100~8500	<b>694.015.40</b>
147	50	2+2	5100~8500	<b>694.015.50</b>

**Spare parts: Head type (1)**

<b>695.015.A1</b>	HWM pair of knives A1 25x29,8x2mm	<b>695.015.D2</b>	HWM pair of knives D2 25x29,8x2mm
<b>695.015.B1</b>	HWM pair of knives B1 25x29,8x2mm	<b>695.015.E2</b>	HWM pair of knives E2 25x29,8x2mm
<b>695.015.C1</b>	HWM pair of knives C1 25x29,8x2mm	<b>695.999.24</b>	Wedge for knives 23x11x9,5mm
<b>695.015.D1</b>	HWM pair of knives D1 25x29,8x2mm	<b>990.084.00</b>	Screw M6x20
<b>695.015.E1</b>	HWM pair of knives E1 25x29,8x2mm		
<b>695.999.23</b>	Wedge for knives 23x11x9,5mm	<b>Head type (3)</b>	
<b>990.084.00</b>	Screw M6x20	<b>790.076.00</b>	Knives 7,65x12x1,5mm

**Head type (2)**

<b>695.015.A2</b>	HWM pair of knives A2 25x29,8x2mm
<b>695.015.B2</b>	HWM pair of knives B2 25x29,8x2mm
<b>695.015.C2</b>	HWM pair of knives C2 25x29,8x2mm

<b>695.999.07</b>	Wedge for knives 6,8x11x9,5mm
<b>990.063.00</b>	Screw M5x18
<b>790.140.00</b>	Knives 14x14x2mm
<b>990.080.00</b>	Screw M5x6,5

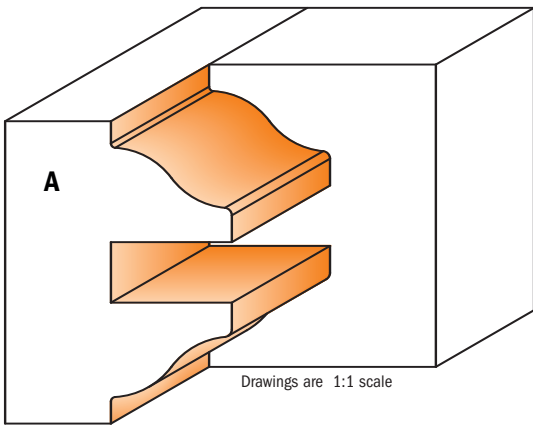

Drawings are 1:1 scale

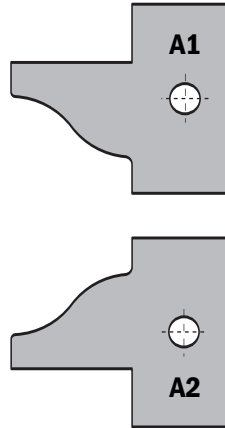

**Technical details:**

- Hard aluminium alloy body with high resistance to tensile and yield stress for type (1 & 2)
- Super-strength steel body for heads type (3)
- 2 HWM Knives type (A1) 25x29,8x2mm [Z2]
- 2 HWM Knives type (A2) 25x29,8x2mm [Z2]
- 2 HWM Knives 7,65x12x1,5mm [Z2]
- 4 HWM Knives 14x14x1,2mm [V4]
- 12 spacer rings from 0,1 to 3 mm for heads type (1 & 2)
- 12 spacer rings from 0,1 to 2 mm for heads type (3)
- Tools for manual feed MAN
- Pins for the automatic positioning of the knives

**Supplied in a solid plastic box**

**OPTIONAL**

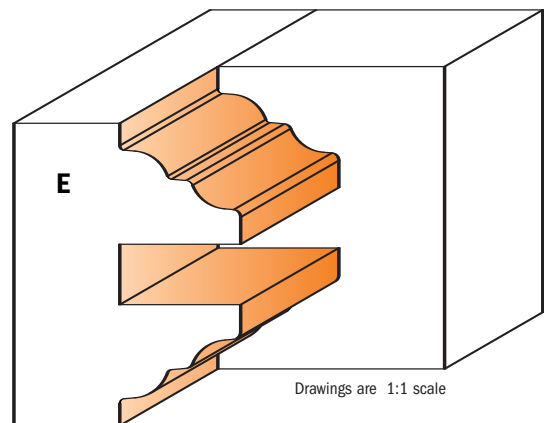
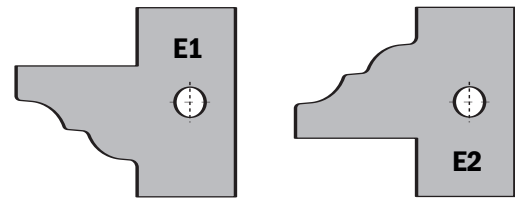
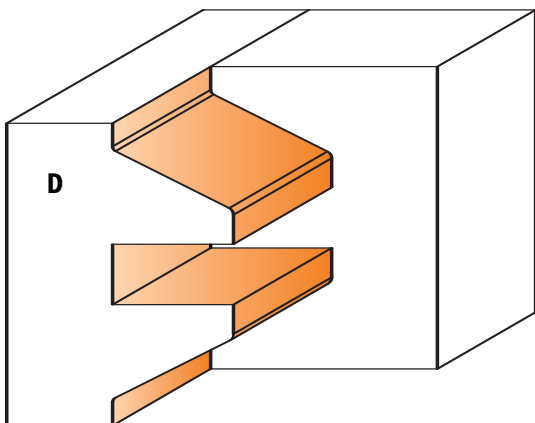
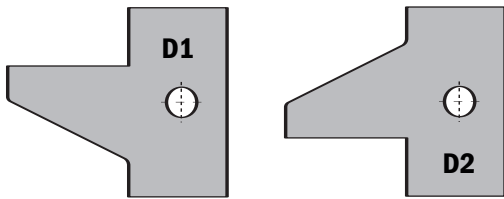
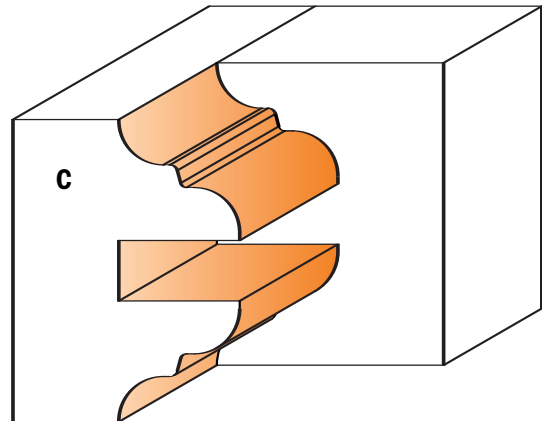
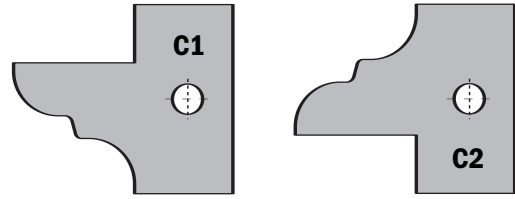
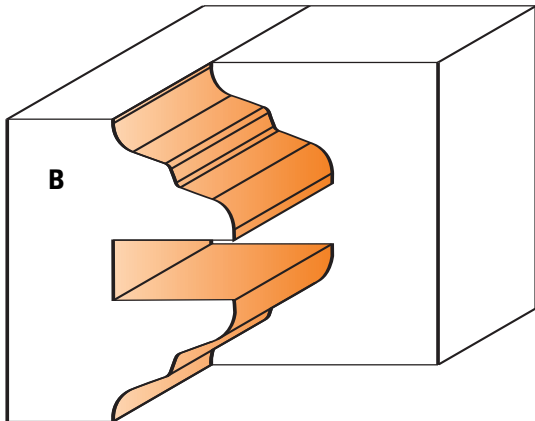
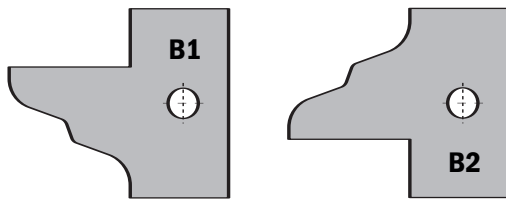

Drawings are 1:1 scale





**692**



CMT cutter heads guarantee a perfect execution for all of your projects. To use on all types of moulder and spindle moulder machines.

**Technical details:**

- Cutter head in hard aluminium alloy with high resistance to tensile and yield stress without limitors
- Pair of universal straight knives
- Tools for mechanical feed MEC
- Pins for the automatic positioning of the knives and the limitors
- Possibility to use knives with a height of 40mm or 50mm (order no. 690)

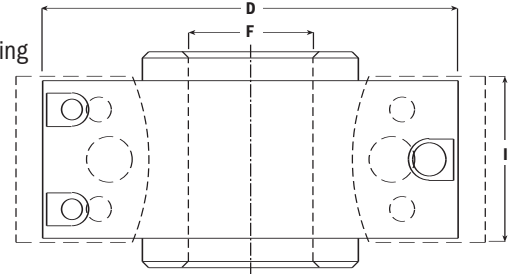

**- Solid plastic box to fit up to 12 couples of knives or limitors**

\* For safety reasons we recommend the use of knives with a 40mm height only.

DESCRIPTION	D Cutting diameter mm	I Cutting length mm	F Bore diameter mm	RPM min. - max	ORDER NO. Steel body	ORDER NO. Alu body
Cutter head	78	40	19,05	7000~9000		<b>692.078.19*</b>
Cutter head	78	40	30	7000~9000		<b>692.078.30*</b>
Cutter head	100	40-50	25,4	5800~9000		<b>692.100.26</b>
Cutter head	100	40-50	30	5800~9000	<b>692.101.30</b>	<b>692.100.30</b>
Cutter head	100	40-50	31,75	5800~9000		<b>692.100.31</b>
Cutter head	100	40-50	35	5800~9000	<b>692.101.35</b>	<b>692.100.35</b>
Cutter head	120	40-50	50	5100~7900	<b>692.121.50</b>	<b>692.120.50</b>

**Spare parts:** 692.999.01 Wedge for knives for code 692 Alu

692.999.02 Wedge for knives for code 692 Steel

# Cutter heads with limitors



**693**



CMT cutter heads guarantee a perfect execution for all of your projects. To use on all types of moulder and spindle moulder machines.

**Technical characteristics:**

- Cutter head in hard aluminium alloy with high resistance to tensile and yield stress with limitors
- Pair of universal straight knives and limitors
- Tools for manual feed MAN
- Pins for the automatic positioning of the knives and the limitors
- Possibility to use knives with a height of 40mm or 50mm (order no. 690) and limitors (order no. 691)
- Built according to the European Normative EN 847-1

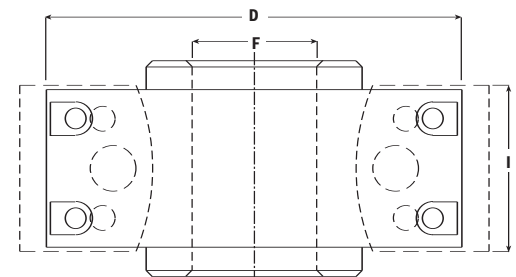

**- Solid plastic box to fit up to 12 couples of knives or limitors**

DESCRIPTION	D Cutting diameter mm	I Cutting length mm	F Bore diameter mm	RPM min. - max	ORDER NO. Steel body	ORDER NO. Alu body
Cutter head with limitors	78	40	30	7000~9000	<b>693.078.30</b>	
Cutter head with limitors	100	40-50	30	5800~9000	<b>693.101.30</b>	<b>693.100.30</b>
Cutter head with limitors	100	40-50	31,75	5800~9000		<b>693.100.31</b>
Cutter head with limitors	100	40-50	35	5800~9000	<b>693.101.35</b>	<b>693.100.35</b>
Cutter head with limitors	120	40-50	50	5100~7900	<b>693.121.50</b>	<b>693.120.50</b>

**Spare parts:** 693.999.01 Wedge for knives for code 693 Alu

693.999.02 Wedge for knives for code 693 Steel

**692**



CMT has selected 13 profiles for the professional woodworker. The set in fact is designed to make joints and frames, and contains 3 essential profiles for the production of kitchen doors. CMT's special construction of the cutter head allows the use of knives with a height of either 40mm or 50mm. We have stored them in a solid plastic box to protect the tools from **accidental** breakage.

**The set includes:**

- 1 cutter head in hard aluminium alloy with pins for the automatic positioning of the knives
- 13 pairs of knives with a cutting height of 40mm (see illustration below).

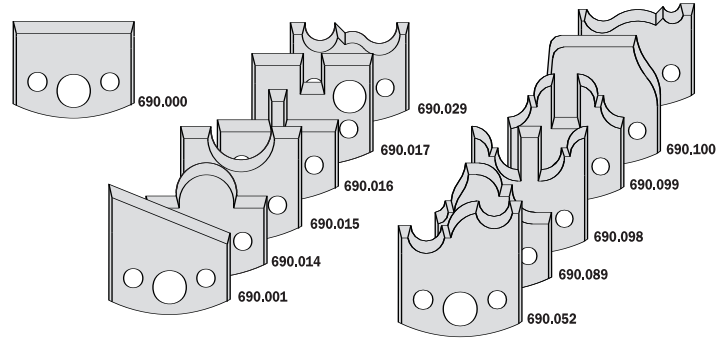

DESCRIPTION	D Cutting diameter mm	I Cutting length mm	F Bore diameter mm inches		RPM min. - max	ORDER NO.
13 piece multiprofile set without limitors of 40mm	78	40	19,05	3/4	7000~9000	<b>692.013.09</b>
13 piece multiprofile set without limitors of 40mm	78	40	30		7000~9000	<b>692.013.01</b>
13 piece multiprofile set without limitors of 40mm	100	40	25,4	1	5800~9000	<b>692.013.10</b>
13 piece multiprofile set without limitors of 40mm	100	40	30		5800~9000	<b>692.013.02</b>
13 piece multiprofile set without limitors of 40mm	100	40	31,75	1-1/4	5800~9000	<b>692.013.11</b>
13 piece multiprofile set without limitors of 40mm	100	40	35		5800~9000	<b>692.013.03</b>
13 piece multiprofile set without limitors of 40mm	120	40	50		5100~7900	<b>692.013.04</b>



CMT has selected 13 profiles for the professional woodworker. The set in fact is designed to make joints and frames, multiprofiles, moldings and chamfers. CMT's special construction of the cutter head allows the use of knives with a height of either 40mm or 50mm. We have stored them in a solid plastic box to protect the tools from accidental breakage.

**The set includes:**

- 1 cutter head in hard aluminium alloy with pins for the automatic positioning of the knives
- 13 pairs of knives with a cutting height of 40mm (see illustration below).

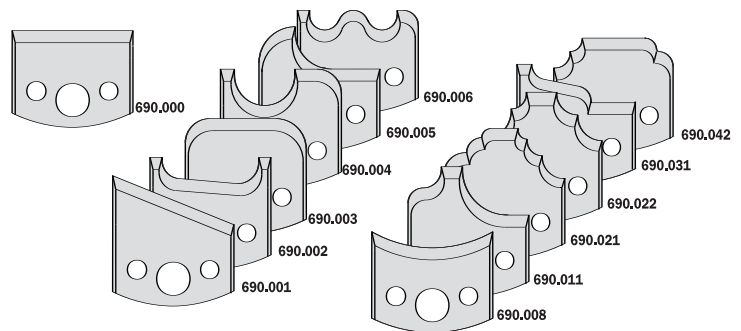

DESCRIPTION	D Cutting diameter mm	I Cutting length mm	F Bore diameter mm inches		RPM min. - max	ORDER NO.
13 piece multiprofile set without limitors of 40mm	78	40	19,05	3/4	7000~9000	<b>692.013.12</b>
13 piece multiprofile set without limitors of 40mm	78	40	30		7000~9000	<b>692.013.05</b>
13 piece multiprofile set without limitors of 40mm	100	40	25,4	1	5800~9000	<b>692.013.13</b>
13 piece multiprofile set without limitors of 40mm	100	40	30		5800~9000	<b>692.013.06</b>
13 piece multiprofile set without limitors of 40mm	100	40	31,75	1-1/4	5800~9000	<b>692.013.14</b>
13 piece multiprofile set without limitors of 40mm	100	40	35		5800~9000	<b>692.013.07</b>
13 piece multiprofile set without limitors of 40mm	120	40	50		5100~7900	<b>692.013.08</b>

693



CMT has selected 7 profiles for the professional woodworker. The set in fact is designed to make kitchen doors with a horizontal profile, and contains two pairs of cutters for male and female joints.

CMT's special construction of the cutter head allows the use of knives with a height of either 40mm or 50mm. The cutter head has safety limitors and it is built according to the European normative EN 847-1.

We have packaged them in a solid plastic box to protect the tools from accidental breakage.

**The set includes:**

1 cutter head in hard aluminium alloy with straight knife and limitor and with pins for the automatic positioning of the knives

7 pairs of knives with 40mm of cutting height as seen in illustration below.

7 pairs of relative limitors.

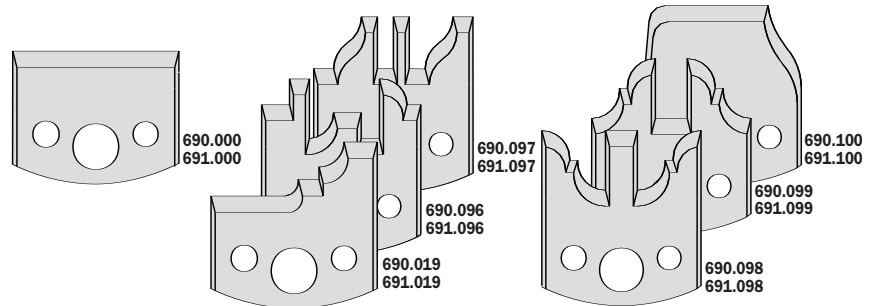

DESCRIPTION	D Cutting diameter mm	I Cutting length mm	F Bore diameter mm	RPM min. - max	ORDER NO.
7 piece kitchen set with limitors of 40mm	100	40	30	5800~9000	<b>693.013.01</b>
7 piece kitchen set with limitors of 40mm	100	40	35	5800~9000	<b>693.013.02</b>
7 piece kitchen set with limitors of 40mm	120	40	50	5100~7900	<b>693.013.03</b>



CMT has selected 7 profiles for the professional woodworker. The set in fact is designed to make joints, frames and chamfers.

CMT's special construction of the cutter head allows the use of knives with a height of either 40mm or 50mm.

The cutter head has safety limitors and it is built according to the European normative EN 847-1. We have packaged them in a solid plastic box to protect the tools from accidental breakage.

**The set includes:**

1 cutter head in hard aluminium alloy with straight knife and limitor and with pins for the automatic positioning of the knives

7 pairs of knives with 40mm of cutting height as seen in illustration below.

7 pairs of relative limitors.

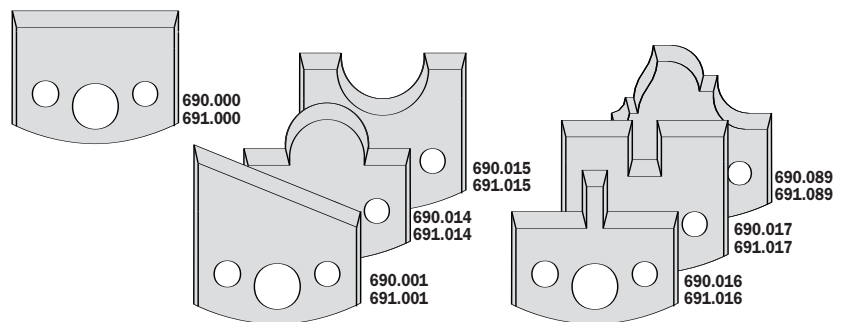

DESCRIPTION	D Cutting diameter mm	I Cutting length mm	F Bore diameter mm	RPM min. - max	ORDER NO.
7 piece kitchen set with limitors of 40mm	100	40	30	5800~9000	<b>693.013.04</b>
7 piece kitchen set with limitors of 40mm	100	40	35	5800~9000	<b>693.013.05</b>
7 piece kitchen set with limitors of 40mm	120	40	50	5100~7900	<b>693.013.06</b>



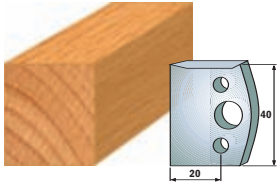

Pair of knives **690.000**  
Pair of limitors **691.000**

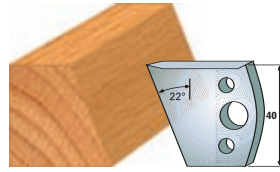

Pair of knives **690.001**  
Pair of limitors **691.001**

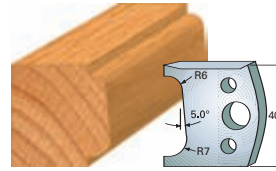

Pair of knives **690.002**  
Pair of limitors **691.002**

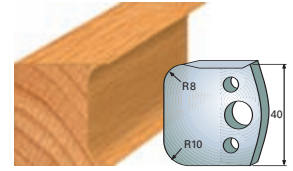

Pair of knives **690.003**  
Pair of limitors **691.003**

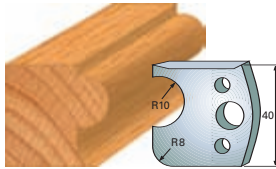

Pair of knives **690.004**  
Pair of limitors **691.004**

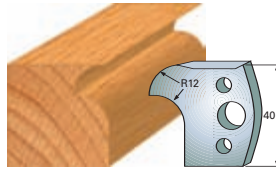

Pair of knives **690.005**  
Pair of limitors **691.005**

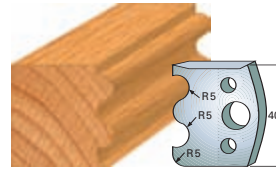

Pair of knives **690.006**  
Pair of limitors **691.006**

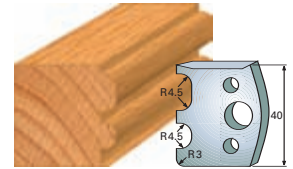

Pair of knives **690.007**  
Pair of limitors **691.007**

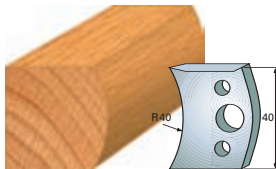

Pair of knives **690.008**  
Pair of limitors **691.008**

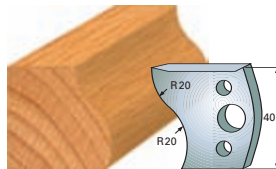

Pair of knives **690.009**  
Pair of limitors **691.009**



Pair of knives **690.010**  
Pair of limitors **691.010**

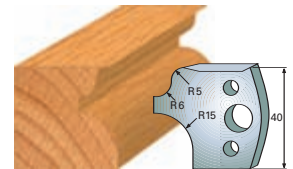

Pair of knives **690.011**  
Pair of limitors **691.011**

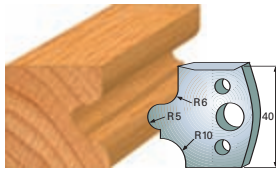

Pair of knives **690.012**  
Pair of limitors **691.012**

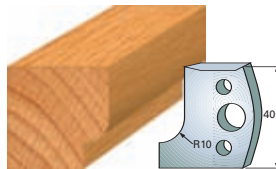

Pair of knives **690.013**  
Pair of limitors **691.013**

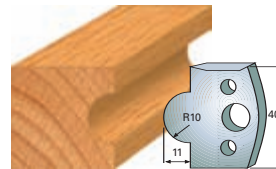

Pair of knives **690.014**  
Pair of limitors **691.014**

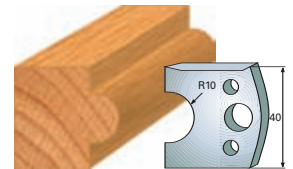

Pair of knives **690.015**  
Pair of limitors **691.015**

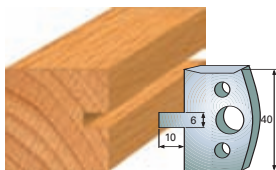

Pair of knives **690.016**  
Pair of limitors **691.016**

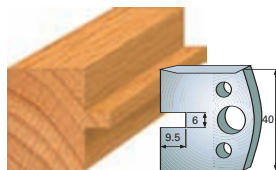

Pair of knives **690.017**  
Pair of limitors **691.017**

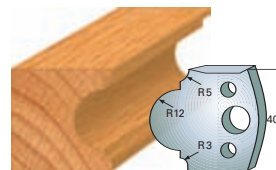

Pair of knives **690.018**  
Pair of limitors **691.018**

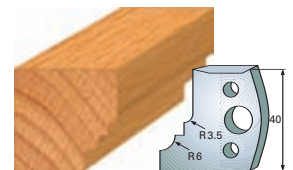

Pair of knives **690.019**  
Pair of limitors **691.019**

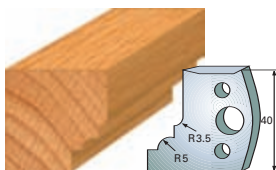

Pair of knives **690.020**  
Pair of limitors **691.020**

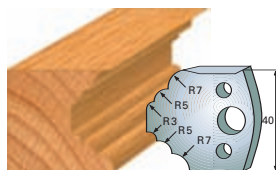

Pair of knives **690.021**  
Pair of limitors **691.021**

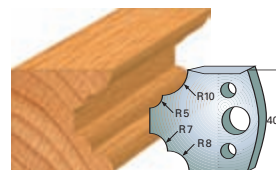

Pair of knives **690.022**  
Pair of limitors **691.022**

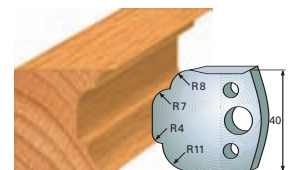

Pair of knives **690.023**  
Pair of limitors **691.023**

Note: all knives and limitors only available in pairs

Drawings are 1:3 scale

Dimensions in mm.



**Profile knives and limitors**  
Cutting length=40mm Thickness=4mm

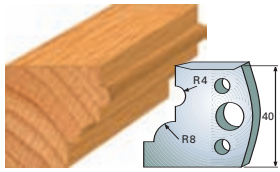

Pair of knives **690.024**  
Pair of limitors **691.024**

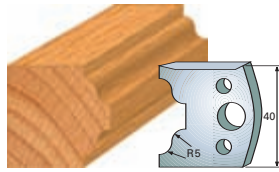

Pair of knives **690.025**  
Pair of limitors **691.025**

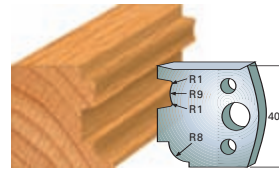

Pair of knives **690.026**  
Pair of limitors **691.026**

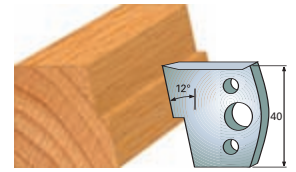

Pair of knives **690.027**  
Pair of limitors **691.027**

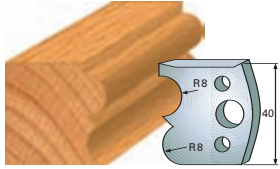

Pair of knives **690.028**  
Pair of limitors **691.028**

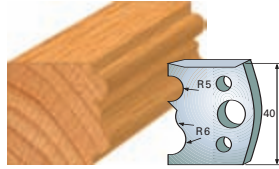

Pair of knives **690.029**  
Pair of limitors **691.029**

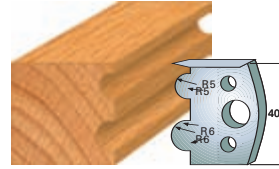

Pair of knives **690.030**  
Pair of limitors **691.030**

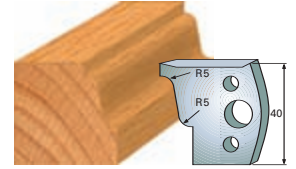

Pair of knives **690.031**  
Pair of limitors **691.031**

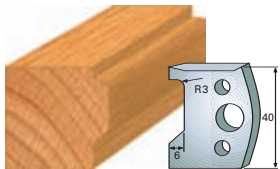

Pair of knives **690.032**  
Pair of limitors **691.032**

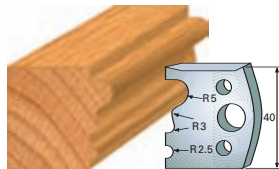

Pair of knives **690.033**  
Pair of limitors **691.033**

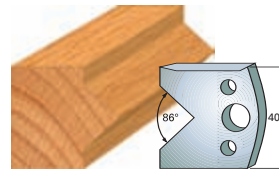

Pair of knives **690.034**  
Pair of limitors **691.034**

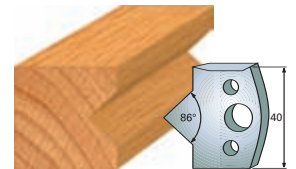

Pair of knives **690.035**  
Pair of limitors **691.035**

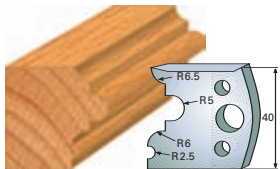

Pair of knives **690.036**  
Pair of limitors **691.036**

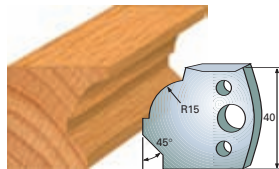

Pair of knives **690.037**  
Pair of limitors **691.037**

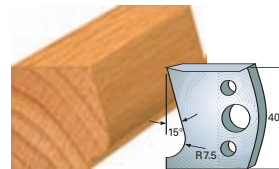

Pair of knives **690.038**  
Pair of limitors **691.038**

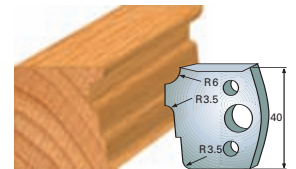

Pair of knives **690.039**  
Pair of limitors **691.039**

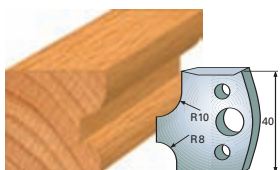

Pair of knives **690.040**  
Pair of limitors **691.040**

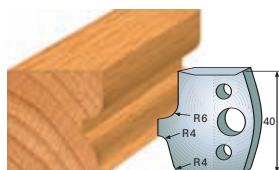

Pair of knives **690.041**  
Pair of limitors **691.041**

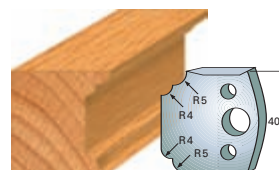

Pair of knives **690.042**  
Pair of limitors **691.042**

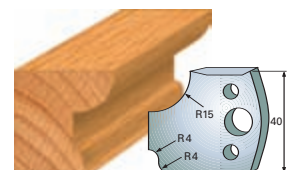

Pair of knives **690.043**  
Pair of limitors **691.043**

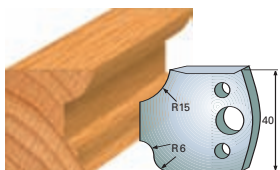

Pair of knives **690.044**  
Pair of limitors **691.044**

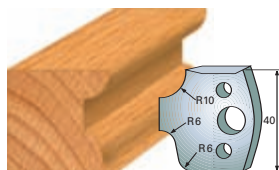

Pair of knives **690.045**  
Pair of limitors **691.045**

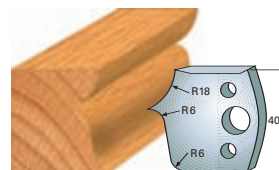

Pair of knives **690.046**  
Pair of limitors **691.046**

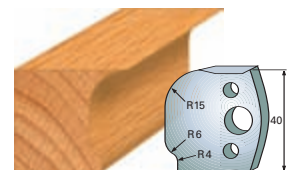

Pair of knives **690.047**  
Pair of limitors **691.047**

Note: all knives and limitors only available in pairs

Drawings are 1:3 scale

Dimensions in mm.

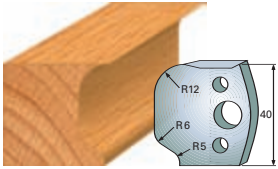

Pair of knives **690.048**  
Pair of limitors **691.048**

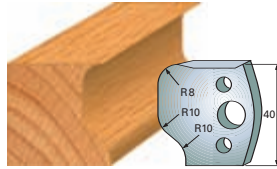

Pair of knives **690.049**  
Pair of limitors **691.049**

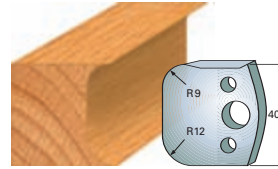

Pair of knives **690.050**  
Pair of limitors **691.050**

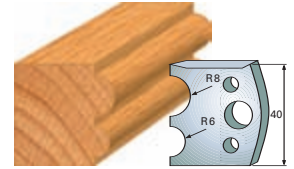

Pair of knives **690.051**  
Pair of limitors **691.051**

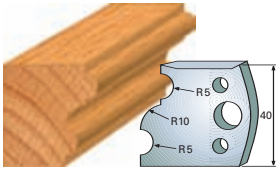

Pair of knives **690.052**  
Pair of limitors **691.052**

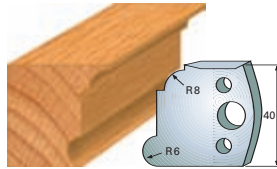

Pair of knives **690.053**  
Pair of limitors **691.053**

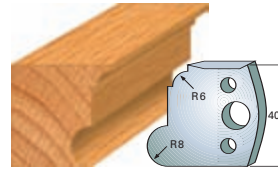

Pair of knives **690.054**  
Pair of limitors **691.054**

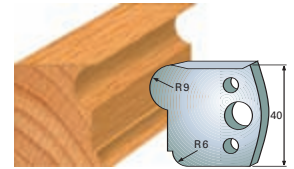

Pair of knives **690.055**  
Pair of limitors **691.055**

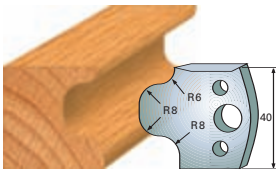

Pair of knives **690.056**  
Pair of limitors **691.056**

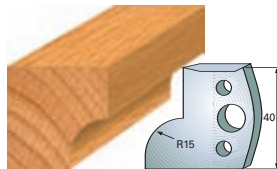

Pair of knives **690.057**  
Pair of limitors **691.057**

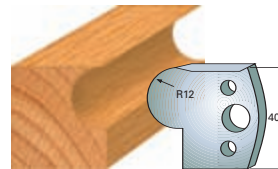

Pair of knives **690.058**  
Pair of limitors **691.058**

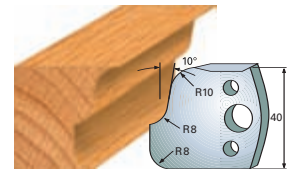

Pair of knives **690.059**  
Pair of limitors **691.059**

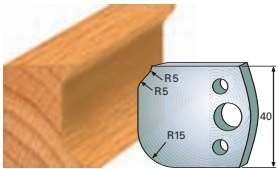

Pair of knives **690.060**  
Pair of limitors **691.060**

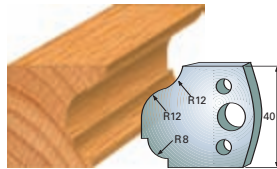

Pair of knives **690.061**  
Pair of limitors **691.061**

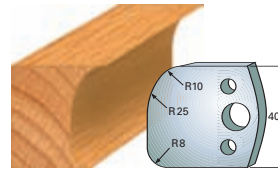

Pair of knives **690.062**  
Pair of limitors **691.062**

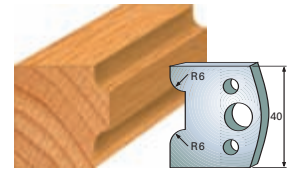

Pair of knives **690.063**  
Pair of limitors **691.063**

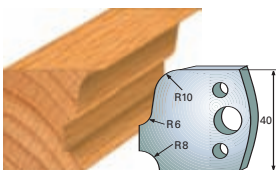

Pair of knives **690.064**  
Pair of limitors **691.064**

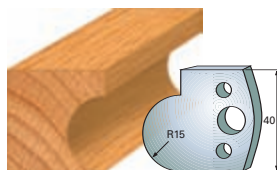

Pair of knives **690.065**  
Pair of limitors **691.065**

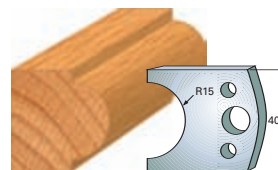

Pair of knives **690.066**  
Pair of limitors **691.066**

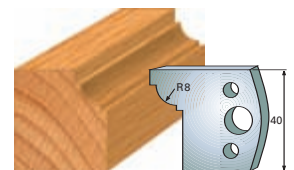

Pair of knives **690.067**  
Pair of limitors **691.067**

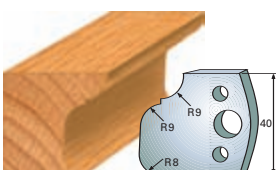

Pair of knives **690.068**  
Pair of limitors **691.068**

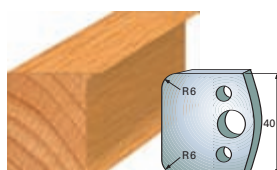

Pair of knives **690.069**  
Pair of limitors **691.069**

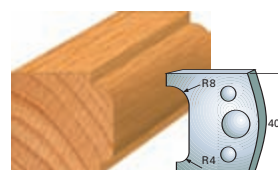

Pair of knives **690.070**  
Pair of limitors **691.070**

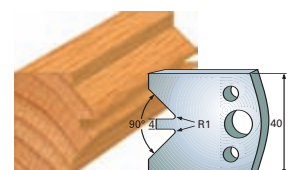

Pair of knives **690.071**  
Pair of limitors **691.071**

Note: all knives and limitors only available in pairs

Drawings are 1:3 scale

Dimensions in mm.



# Profile knives and limitors

Cutting length=40mm Thickness=4mm

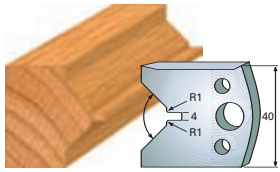

Pair of knives **690.072**  
Pair of limitors **691.072**

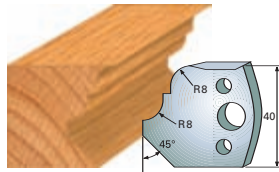

Pair of knives **690.073**  
Pair of limitors **691.073**

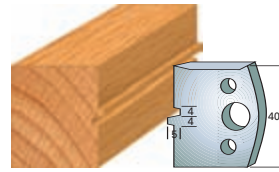

Pair of knives **690.074**  
Pair of limitors **691.074**

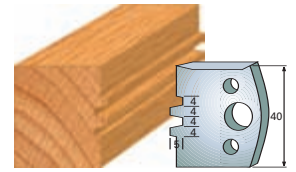

Pair of knives **690.075**  
Pair of limitors **691.075**

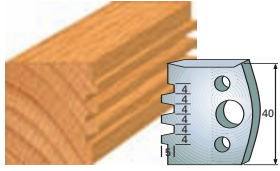

Pair of knives **690.076**  
Pair of limitors **691.076**

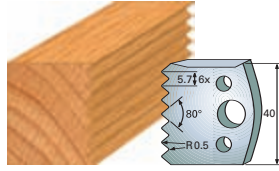

Pair of knives **690.077**  
Pair of limitors **691.077**

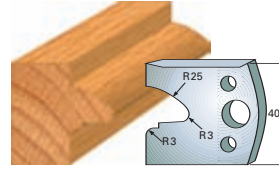

Pair of knives **690.078**  
Pair of limitors **691.078**

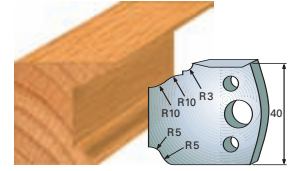

Pair of knives **690.079**  
Pair of limitors **691.079**

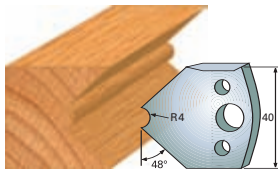

Pair of knives **690.080**  
Pair of limitors **691.080**

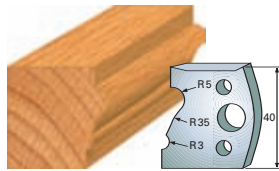

Pair of knives **690.081**  
Pair of limitors **691.081**

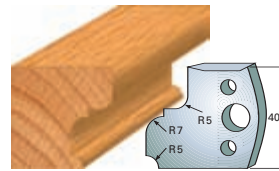

Pair of knives **690.082**  
Pair of limitors **691.082**

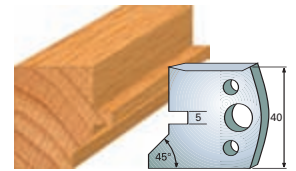

Pair of knives **690.083**  
Pair of limitors **691.083**

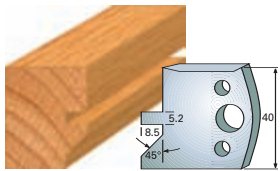

Pair of knives **690.084**  
Pair of limitors **691.084**

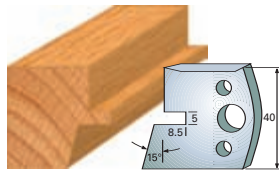

Pair of knives **690.085**  
Pair of limitors **691.085**

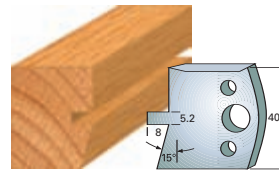

Pair of knives **690.086**  
Pair of limitors **691.086**

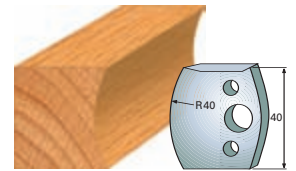

Pair of knives **690.087**  
Pair of limitors **691.087**

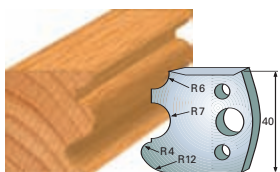

Pair of knives **690.088**  
Pair of limitors **691.088**

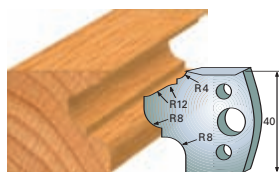

Pair of knives **690.089**  
Pair of limitors **691.089**

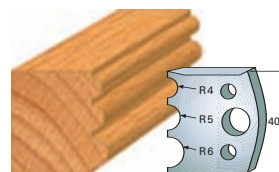

Pair of knives **690.090**  
Pair of limitors **691.090**

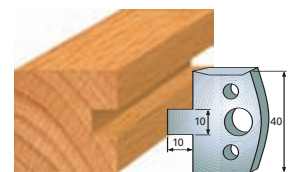

Pair of knives **690.091**  
Pair of limitors **691.091**

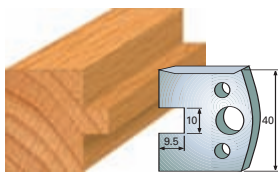

Pair of knives **690.092**  
Pair of limitors **691.092**

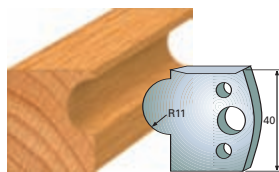

Pair of knives **690.093**  
Pair of limitors **691.093**

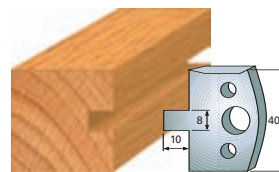

Pair of knives **690.094**  
Pair of limitors **691.094**

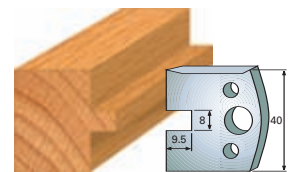

Pair of knives **690.095**  
Pair of limitors **691.095**

Note: all knives and limitors only available in pairs

Drawings are 1:3 scale

Dimensions in mm.

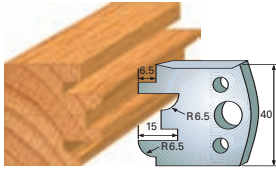

Pair of knives **690.096**  
Pair of limitors **691.096**

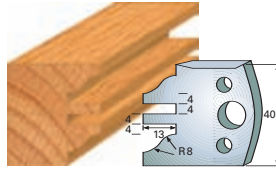

Pair of knives **690.097**  
Pair of limitors **691.097**

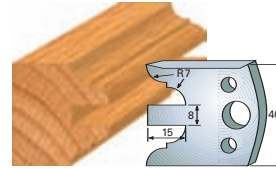

Pair of knives **690.098**  
Pair of limitors **691.098**

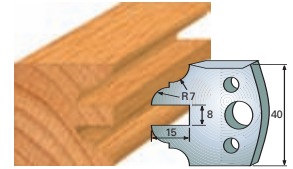

Pair of knives **690.099**  
Pair of limitors **691.099**

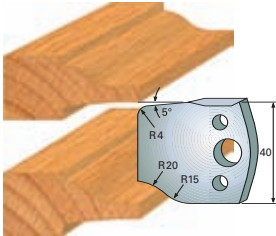

Pair of knives **690.100**  
Pair of limitors **691.100**

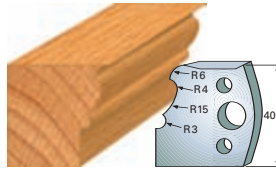

Pair of knives **690.101**  
Pair of limitors **691.101**

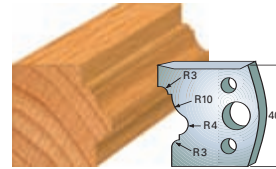

Pair of knives **690.102**  
Pair of limitors **691.102**

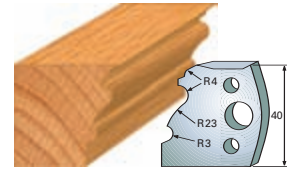

Pair of knives **690.103**  
Pair of limitors **691.103**

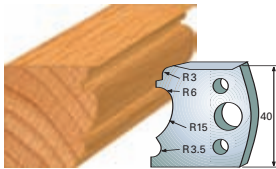

Pair of knives **690.104**  
Pair of limitors **691.104**

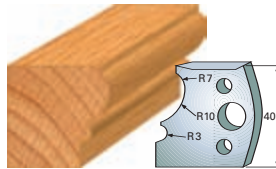

Pair of knives **690.105**  
Pair of limitors **691.105**

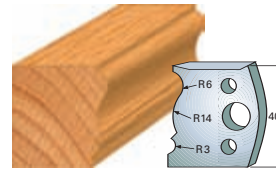

Pair of knives **690.106**  
Pair of limitors **691.106**

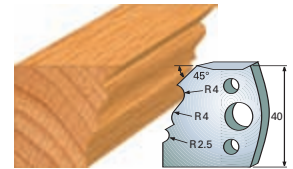

Pair of knives **690.107**  
Pair of limitors **691.107**

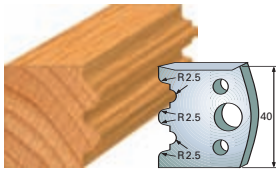

Pair of knives **690.108**  
Pair of limitors **691.108**

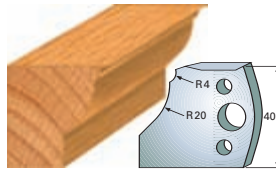

Pair of knives **690.109**  
Pair of limitors **691.109**

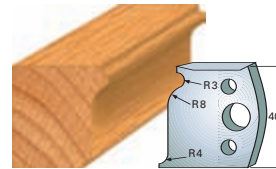

Pair of knives **690.110**  
Pair of limitors **691.110**

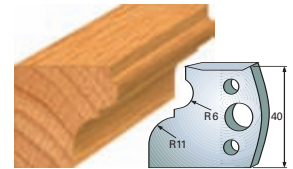

Pair of knives **690.111**  
Pair of limitors **691.111**

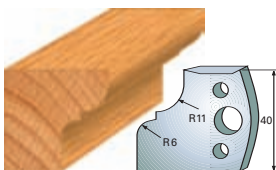

Pair of knives **690.112**  
Pair of limitors **691.112**

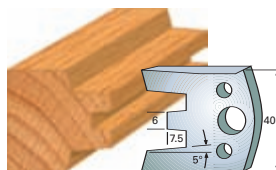

Pair of knives **690.113**  
Pair of limitors **691.113**

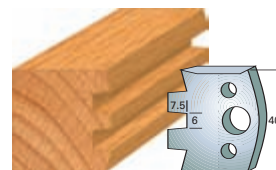

Pair of knives **690.114**  
Pair of limitors **691.114**

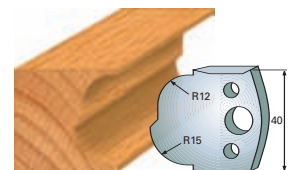

Pair of knives **690.115**  
Pair of limitors **691.115**

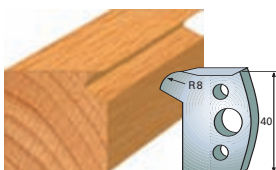

Pair of knives **690.116**  
Pair of limitors **691.116**

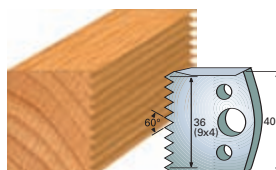

Pair of knives **690.117**  
Pair of limitors **691.117**

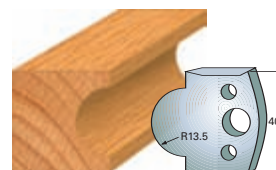

Pair of knives **690.118**  
Pair of limitors **691.118**

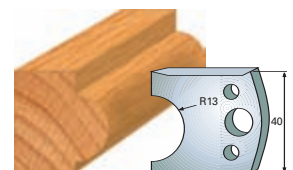

Pair of knives **690.119**  
Pair of limitors **691.119**

Note: all knives and limitors only available in pairs

Drawings are 1:3 scale

Dimensions in mm.



**Profile knives and limitors**  
Cutting length=40mm Thickness=4mm

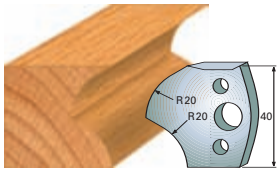

Pair of knives **690.120**  
Pair of limitors **691.120**

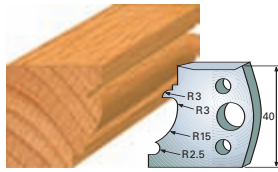

Pair of knives **690.121**  
Pair of limitors **691.121**

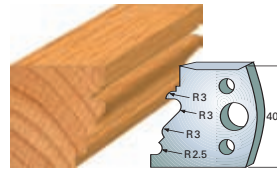

Pair of knives **690.122**  
Pair of limitors **691.122**

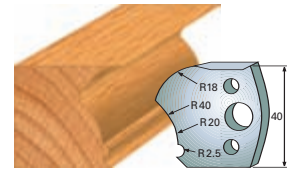

Pair of knives **690.123**  
Pair of limitors **691.123**

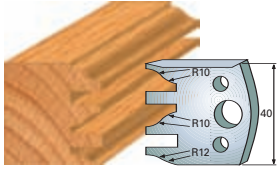

Pair of knives **690.124**  
Pair of limitors **691.124**

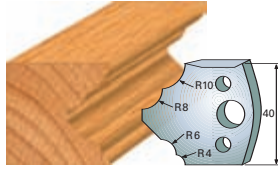

Pair of knives **690.125**  
Pair of limitors **691.125**

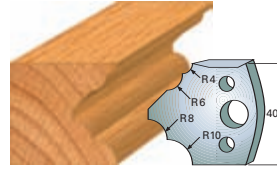

Pair of knives **690.126**  
Pair of limitors **691.126**

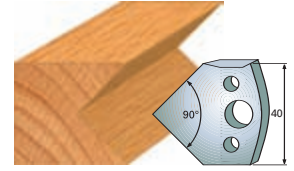

Pair of knives **690.127**  
Pair of limitors **691.127**

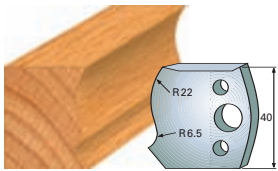

Pair of knives **690.128**  
Pair of limitors **691.128**

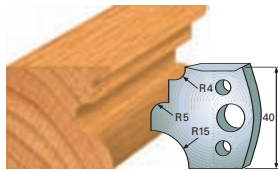

Pair of knives **690.129**  
Pair of limitors **691.129**

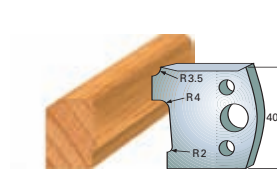

Pair of knives **690.130**  
Pair of limitors **691.130**

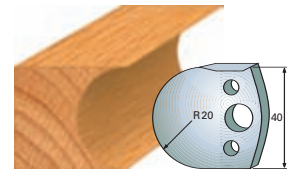

Pair of knives **690.131**  
Pair of limitors **691.131**

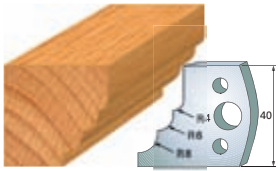

Pair of knives **690.132**  
Pair of limitors **691.132**

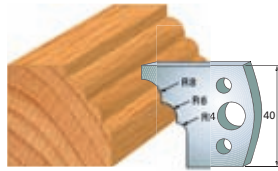

Pair of knives **690.133**  
Pair of limitors **691.133**

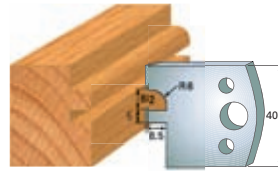

Pair of knives **690.134**  
Pair of limitors **691.134**

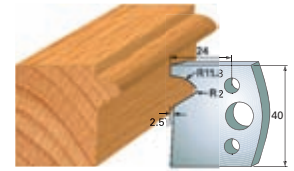

Pair of knives **690.135**  
Pair of limitors **691.135**

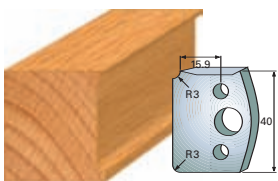

Pair of knives **690.170**  
Pair of limitors **691.170**

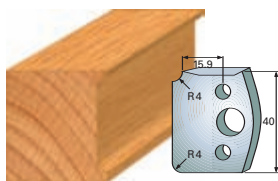

Pair of knives **690.171**  
Pair of limitors **691.171**

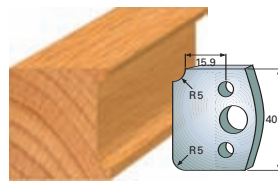

Pair of knives **690.172**  
Pair of limitors **691.172**

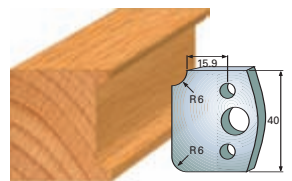

Pair of knives **690.173**  
Pair of limitors **691.173**

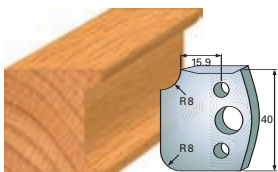

Pair of knives **690.174**  
Pair of limitors **691.174**

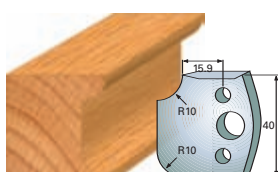

Pair of knives **690.175**  
Pair of limitors **691.175**

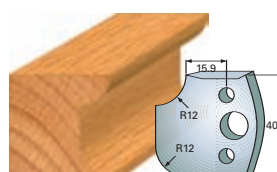

Pair of knives **690.176**  
Pair of limitors **691.176**

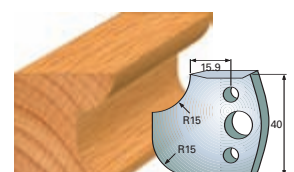

Pair of knives **690.177**  
Pair of limitors **691.177**

Note: all knives and limitors only available in pairs

Drawings are 1:3 scale

Dimensions in mm.

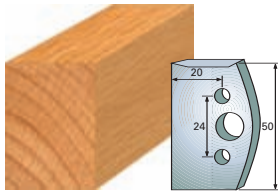

Pair of knives **690.500**  
Pair of limitors **691.500**

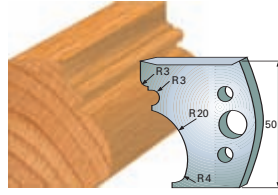

Pair of knives **690.501**  
Pair of limitors **691.501**

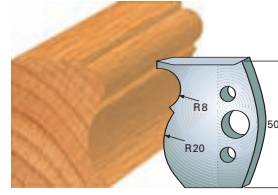

Pair of knives **690.502**  
Pair of limitors **691.502**

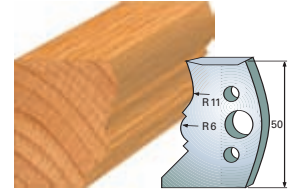

Pair of knives **690.503**  
Pair of limitors **691.503**

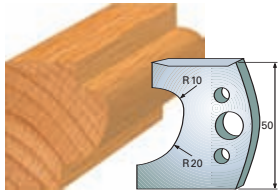

Pair of knives **690.504**  
Pair of limitors **691.504**

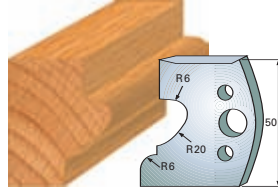

Pair of knives **690.505**  
Pair of limitors **691.505**

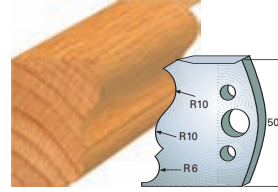

Pair of knives **690.506**  
Pair of limitors **691.506**

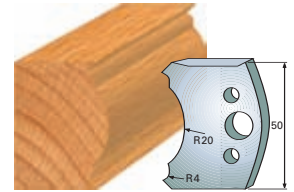

Pair of knives **690.507**  
Pair of limitors **691.507**

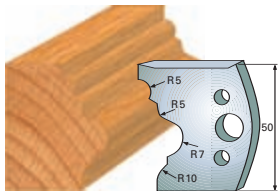

Pair of knives **690.508**  
Pair of limitors **691.508**

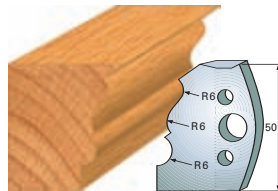

Pair of knives **690.509**  
Pair of limitors **691.509**

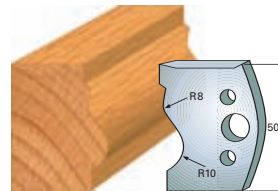

Pair of knives **690.510**  
Pair of limitors **691.510**

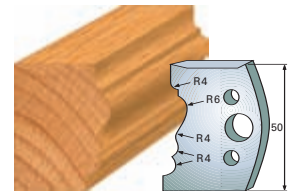

Pair of knives **690.511**  
Pair of limitors **691.511**

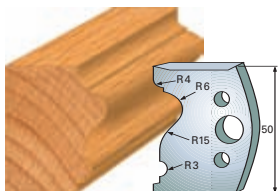

Pair of knives **690.512**  
Pair of limitors **691.512**

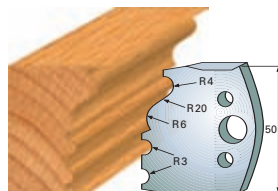

Pair of knives **690.513**  
Pair of limitors **691.513**

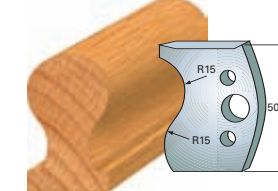

Pair of knives **690.514**  
Pair of limitors **691.514**

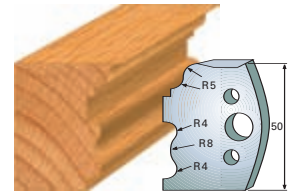

Pair of knives **690.515**  
Pair of limitors **691.515**

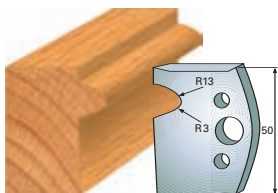

Pair of knives **690.516**  
Pair of limitors **691.516**

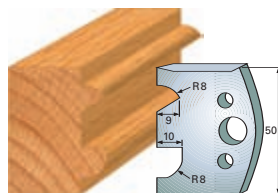

Pair of knives **690.517**  
Pair of limitors **691.517**

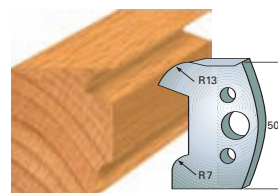

Pair of knives **690.518**  
Pair of limitors **691.518**

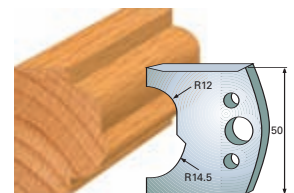

Pair of knives **690.519**  
Pair of limitors **691.519**

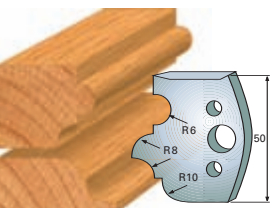

Pair of knives **690.520**  
Pair of limitors **691.520**

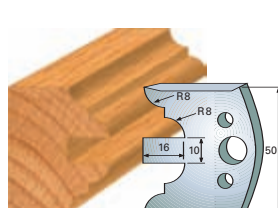

Pair of knives **690.522**  
Pair of limitors **691.522**

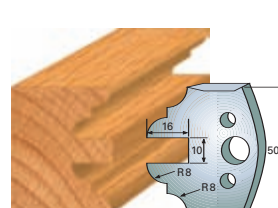

Pair of knives **690.523**  
Pair of limitors **691.523**

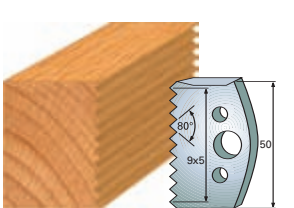

Pair of knives **690.524**  
Pair of limitors **691.524**

Note: all knives and limitors only available in pairs

Drawings are 1:3 scale

Dimensions in mm.



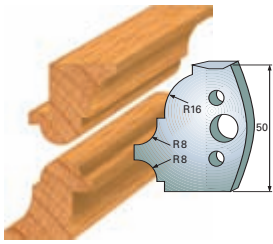

Pair of knives **690.541**  
Pair of limiters **691.541**

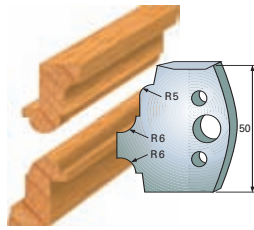

Pair of knives **690.542**  
Pair of limiters **691.542**

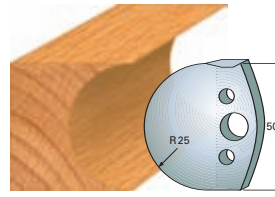

Pair of knives **690.543**  
Pair of limiters **691.543**

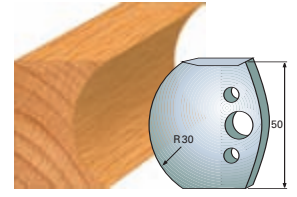

Pair of knives **690.544**  
Pair of limiters **691.544**

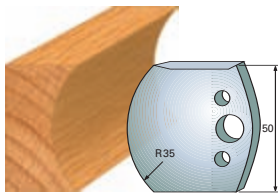

Pair of knives **690.545**  
Pair of limiters **691.545**

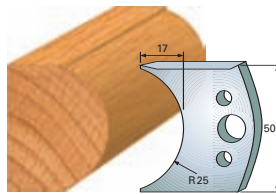

Pair of knives **690.546**  
Pair of limiters **691.546**

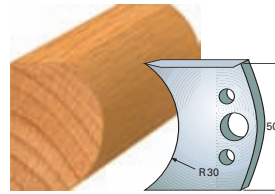

Pair of knives **690.547**  
Pair of limiters **691.547**

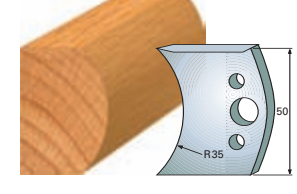

Pair of knives **690.548**  
Pair of limiters **691.548**

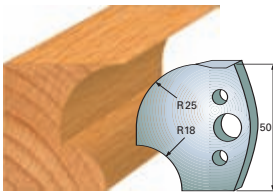

Pair of knives **690.549**  
Pair of limiters **691.549**

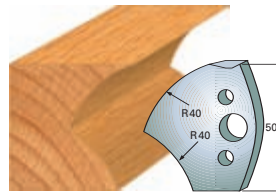

Pair of knives **690.550**  
Pair of limiters **691.550**

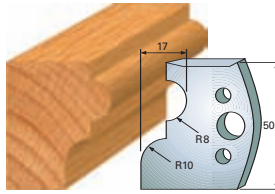

Pair of knives **690.551**  
Pair of limiters **691.551**

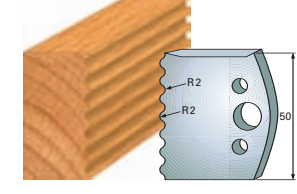

Pair of knives **690.552**  
Pair of limiters **691.552**

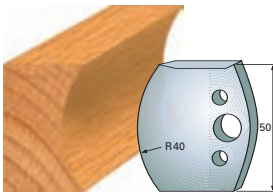

Pair of knives **690.553**  
Pair of limiters **691.553**

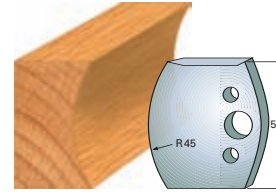

Pair of knives **690.554**  
Pair of limiters **691.554**

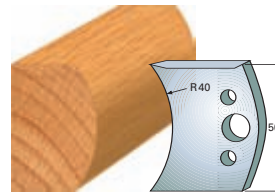

Pair of knives **690.555**  
Pair of limiters **691.555**

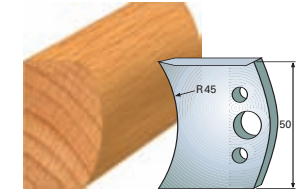

Pair of knives **690.556**  
Pair of limiters **691.556**

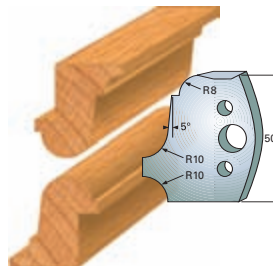

Pair of knives **690.557**  
Pair of limiters **691.557**

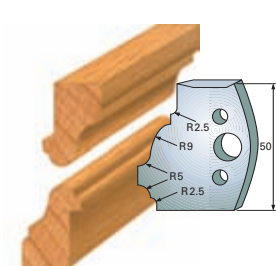

Pair of knives **690.558**  
Pair of limiters **691.558**

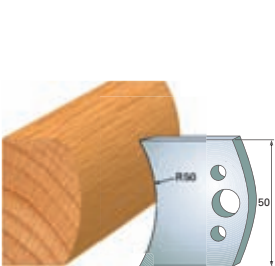

Pair of knives **690.559**  
Pair of limiters **691.559**

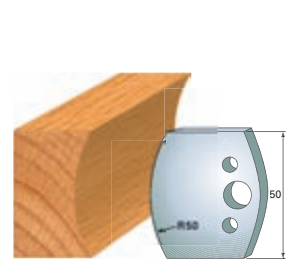

Pair of knives **690.560**  
Pair of limiters **691.560**



Pair of knives **690.561**  
Pair of limiters **691.561**

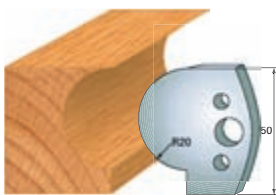

Pair of knives **690.562**  
Pair of limiters **691.562**

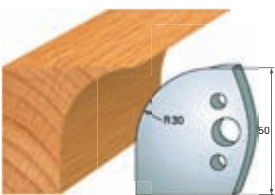

Pair of knives **690.563**  
Pair of limiters **691.563**



Pair of knives **690.564**  
Pair of limiters **691.564**

Note: all knives and limiters only available in pairs

Drawings are 1:3 scale

Dimensions in mm.

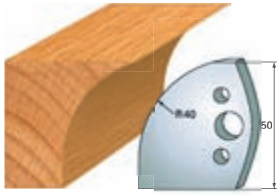

Pair of knives **690.565**  
Pair of limitors **691.565**

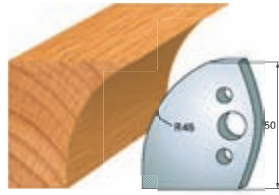

Pair of knives **690.566**  
Pair of limitors **691.566**



Pair of knives **690.567**  
Pair of limitors **691.567**

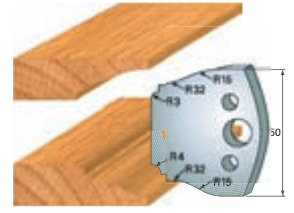

Pair of knives **690.568**  
Pair of limitors **691.568**

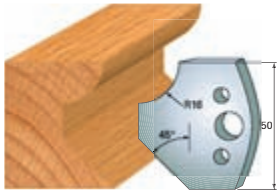

Pair of knives **690.569**  
Pair of limitors **691.569**

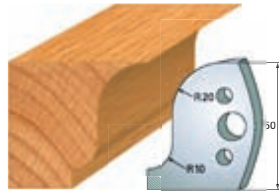

Pair of knives **690.570**  
Pair of limitors **691.570**

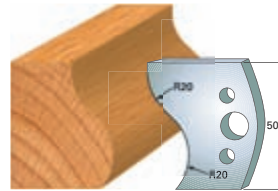

Pair of knives **690.571**  
Pair of limitors **691.571**

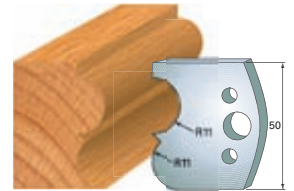

Pair of knives **690.572**  
Pair of limitors **691.572**

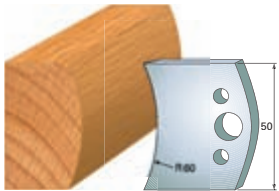

Pair of knives **690.573**  
Pair of limitors **691.573**

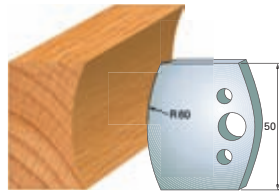

Pair of knives **690.574**  
Pair of limitors **691.574**

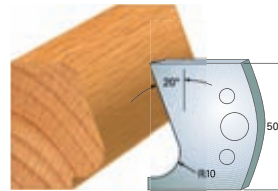

Pair of knives **690.575**  
Pair of limitors **691.575**

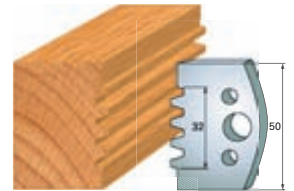

Pair of knives **690.576**  
Pair of limitors **691.576**

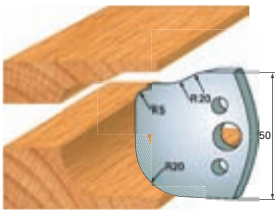

Pair of knives **690.577**  
Pair of limitors **691.577**

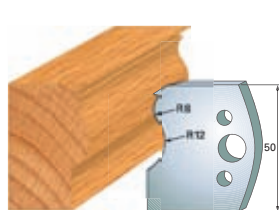

Pair of knives **690.578**  
Pair of limitors **691.578**

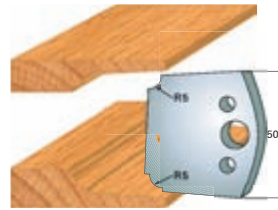

Pair of knives **690.579**  
Pair of limitors **691.579**

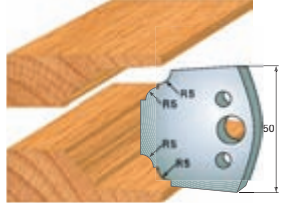

Pair of knives **690.580**  
Pair of limitors **691.580**

Note: all knives and limitors only available in pairs

Drawings are 1:3 scale

Dimensions in mm.

**Knives and limitors (long series)**

DESCRIPTION	LB Adjusting length mm	I Cutting length mm	ORDER NO.
Pair of knives	24	40	<b>690.192</b>
Pair of limitors	24	40	<b>691.192</b>

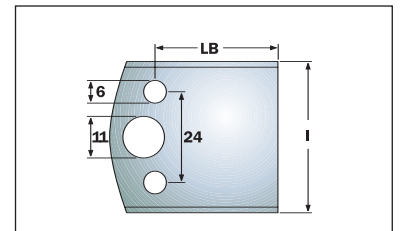

**Blank knives and limitors (to be sharpened)**

DESCRIPTION	LB Adjusting length mm	I Cutting length mm	ORDER NO.
Pair of blank knives	32,5	40	<b>690.193</b>
Pair of blank knives	34	50	<b>690.599</b>
Pair of blank limitors	32,5	40	<b>691.193</b>
Pair of blank limitors	34	50	<b>691.599</b>

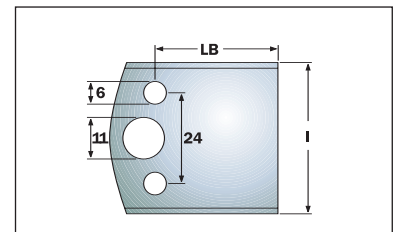





Pair of bore reducer 50-40mm	<b>699.050.40</b>
Pair of bore reducer 50-35mm	<b>699.050.35</b>
Pair of bore reducer 50-30mm	<b>699.050.30</b>
Pair of bore reducer 35-31,75mm	<b>699.035.31</b>
Pair of bore reducer 35-30mm	<b>699.035.30</b>
Pair of bore reducer 31,75-30mm	<b>699.031.30</b>
Pair of bore reducer 31,75-25,4mm	<b>699.031.26</b>
Pair of bore reducer 31,75-19,05mm	<b>699.031.19</b>
Pair of bore reducer 30-25,4mm	<b>699.030.26</b>
Pair of bore reducer 30-19,05mm	<b>699.030.19</b>
Pair of bore reducer 25,4-19,05mm	<b>699.026.19</b>
Pair of bore reducer 19,05-12,7mm	<b>699.019.13</b>

**To be used in pair only**

## Safety

- ALWAYS** thoroughly check all cutters for damage and flaws before using.
- ALWAYS** wear safety glasses and ear protection when using power tools.
- ALWAYS** thoroughly read the owners manual and manufacturer's instructions before working with tools.
- ALWAYS** use guards that were supplied with your shaper.
- ALWAYS** use a fence with your shaper. Do not make freehand cuts.
- ALWAYS** use pusher blocks, especially when working with small or narrow pieces.
- ALWAYS** unplug your shaper before cleaning or adjusting the tool, or before making cutter or knife changes.
- ALWAYS** be sure the spindle nut is tight before plugging in the shaper.
- ALWAYS** check that knives are properly and securely installed in the cutterhead when using interchangeable-knife systems.
- ALWAYS** keep your tools sharpened, clean and stored in a safe place to avoid breakage and accidents and to extend the life of your bits and blades.
- ALWAYS** feed the work against the rotation of the knives.
- ALWAYS** be sure your workpiece is completely supported, before and after the cut.
- NEVER** remove guards or any other safety devices from your shaper.
- NEVER** use dull or damaged knives.
- NEVER** force the cut or overload the shaper.
- NEVER** change cutters or knives or make adjustments with the shaper plugged in.
- NEVER** make adjustments to the shaper while the cutter is turning.

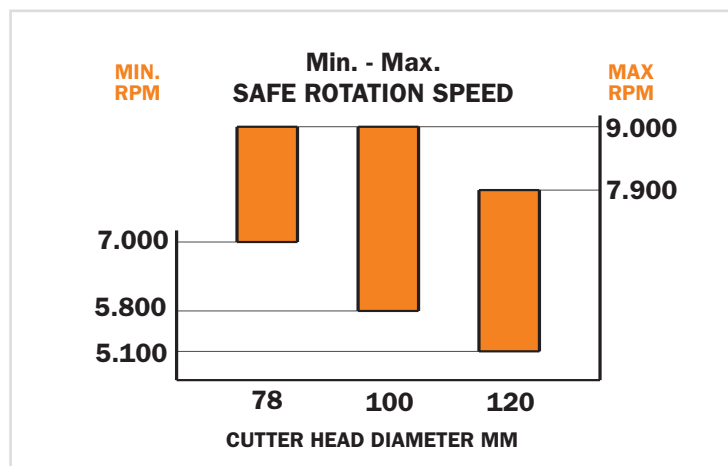

**793**

Sizes L H K mm	Material	Nr. pair of knives per set	ORDER NO. HWM
40 x 50 x 8	HS 6%W	4	<b>793.040.50</b>
40 x 60 x 8	HS 6%W	4	<b>793.040.60</b>
40 x 70 x 8	HS 6%W	4	<b>793.040.70</b>
60 x 50 x 8	HS 6%W	4	<b>793.060.50</b>
60 x 60 x 8	HS 6%W	4	<b>793.060.60</b>
60 x 70 x 8	HS 6%W	4	<b>793.060.70</b>
80 x 50 x 8	HS 6%W	4	<b>793.080.50</b>
80 x 60 x 8	HS 6%W	4	<b>793.080.60</b>
80 x 70 x 8	HS 6%W	4	<b>793.080.70</b>
100 x 50 x 8	HS 6%W	4	<b>793.100.50</b>
100 x 60 x 8	HS 6%W	4	<b>793.100.60</b>
100 x 70 x 8	HS 6%W	4	<b>793.100.70</b>
120 x 50 x 8	HS 6%W	4	<b>793.120.50</b>
120 x 60 x 8	HS 6%W	4	<b>793.120.60</b>
120 x 70 x 8	HS 6%W	4	<b>793.120.70</b>
130 x 60 x 8	HS 6%W	4	<b>793.130.60</b>
130 x 70 x 8	HS 6%W	4	<b>793.130.70</b>
650 x 40 x 8	HS 6%W	4	<b>793.650.40</b>
650 x 50 x 8	HS 6%W	4	<b>793.650.50</b>
650 x 60 x 8	HS 6%W	4	<b>793.650.60</b>
650 x 70 x 8	HS 6%W	4	<b>793.650.70</b>

**REMARK:** special dimensions available on request.

**TECHNICAL DETAILS:**

Corrugated back moulder knives for profile cutterheads with precision serration, angle 60°, pitch 1,6mm.

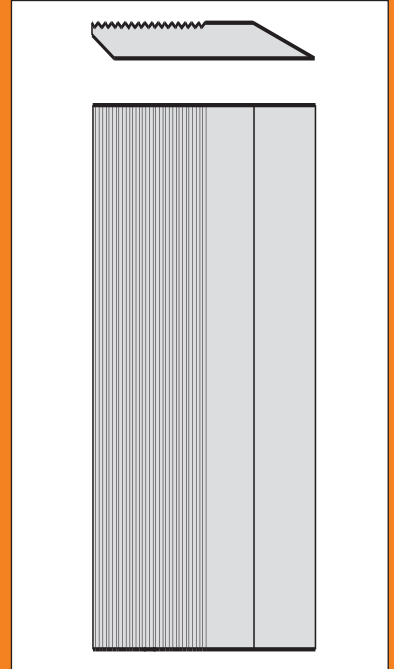
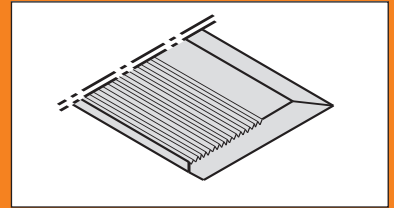
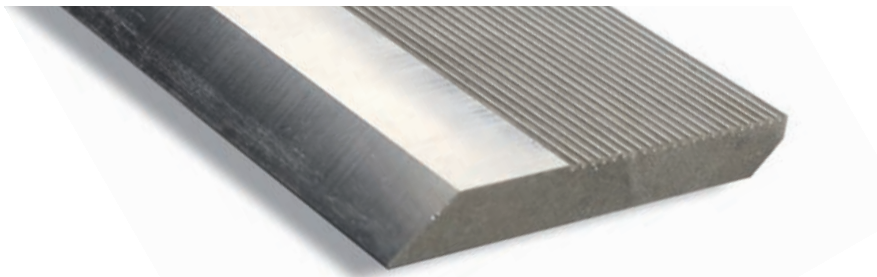

IN QUADROPACK PACKAGING

MATERIAL	HS 6% W
Dry Softwood	1
Wet Softwood	1
Dry Hardwood	1
Wet Hardwood	m
1 Suitable	

**Magnetic knife setting jigs**

The best knives won't perform well unless they are properly installed and aligned. The built-in magnets grip both the planer head and the knives while you use the integral adjustments to get the knives in perfect position.

**CMT792**

- 1. MAGNETIZED CERAMIC STOP**
  - 2. JOINTS WITH MAGNETIZED CONNECTORS**
  - 3. PRECISION DEPTH STOP**
- Set supplied in a wooden box with 2 setters and gauges tickness 0,8 - 1 - 1,2mm.

**3 possibilities of setting up**

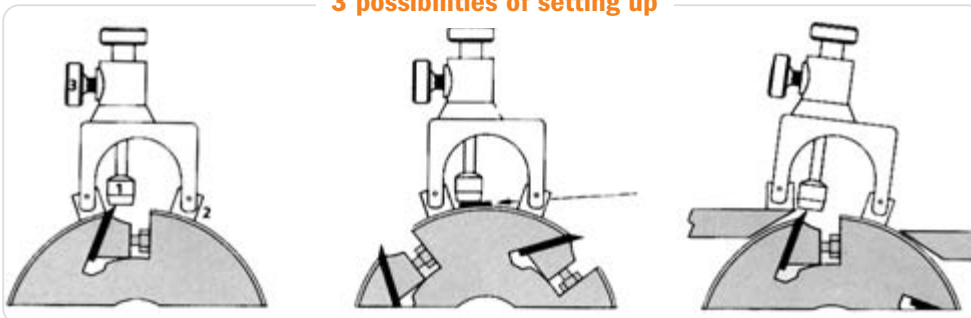

Positioning onto the toolholder body with marking onto the original knife.

Positioning onto the toolholder body setting with one of the supplied gauges.

Positioning directly onto the machine table and the toolholder body.



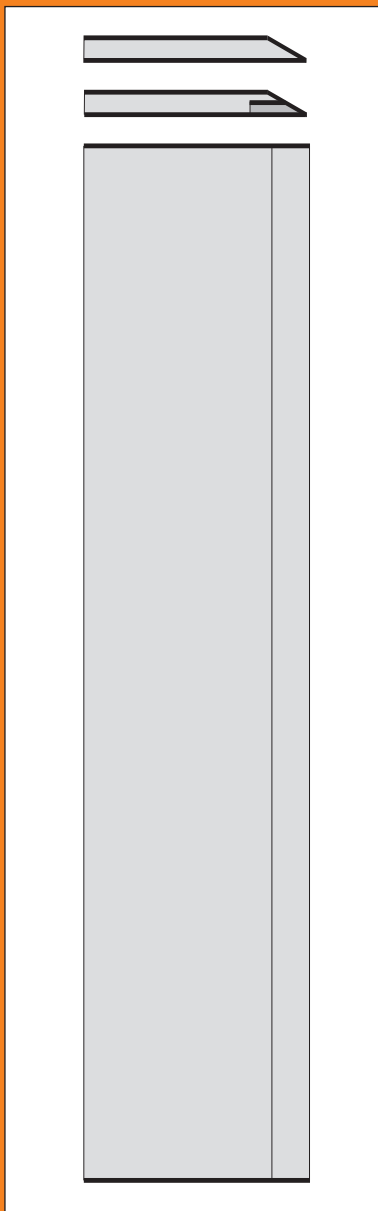
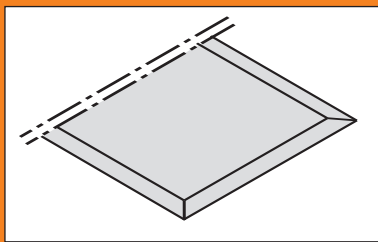

IN QUADROPACK PACKAGING

MATERIAL	6%W	18%W	HW
Dry Softwood	1	1	
Wet Softwood	1	m	
Dry Hardwood	m	1	1
Wet Hardwood	m	1	m
Chipboard			m
MDF			m
Glulam		m	1

1 Suitable

Sizes L H K mm	Knives per set	ORDER NO. HS 6%W	ORDER NO. HS 18%W	ORDER NO. HW
120 x 30 x 3	2		792.120.30	
130 x 30 x 3	2	792.131.30	792.130.30	792.132.30
150 x 30 x 3	2		792.150.30	
180 x 30 x 3	2	792.181.30	792.180.30	792.182.30
200 x 30 x 3	2	792.201.30	792.200.30	
210 x 30 x 3	2	792.211.30	792.210.30	
230 x 30 x 3	2	792.231.30	792.230.30	792.232.30
250 x 30 x 3	2	792.251.30	792.250.30	792.252.30
260 x 30 x 3	2	792.261.30	792.260.30	792.262.30
300 x 30 x 3	2	792.301.30	792.300.30	792.302.30
310 x 30 x 3	2	792.311.30	792.310.30	792.312.30
350 x 30 x 3	2	792.351.30	792.350.30	792.352.30
400 x 30 x 3	2	792.401.30	792.400.30	792.402.30
410 x 30 x 3	2	792.411.30	792.410.30	792.412.30
430 x 30 x 3	2	792.431.30	792.430.30	792.432.30
450 x 30 x 3	2	792.451.30	792.450.30	792.452.30
500 x 30 x 3	2	792.501.30	792.500.30	792.502.30
510 x 30 x 3	2	792.511.30	792.510.30	792.512.30
520 x 30 x 3	2	792.521.30	792.520.30	792.522.30
530 x 30 x 3	2	792.531.30	792.530.30	792.532.30
600 x 30 x 3	2	792.601.30	792.600.30	792.602.30
610 x 30 x 3	2	792.611.30	792.610.30	792.612.30
630 x 30 x 3	2	792.631.30	792.630.30	792.632.30
640 x 30 x 3	2		792.640.30	
710 x 30 x 3	2		792.710.30	
810 x 30 x 3	2	792.811.30	792.810.30	792.812.30
1070 x 30 x 3	2	792.998.30	792.997.30	792.999.30
300 x 35 x 3	2		792.300.35	
310 x 35 x 3	2	792.311.35		
350 x 35 x 3	2	792.351.35	792.350.35	
400 x 35 x 3	2	792.401.35	792.400.35	
410 x 35 x 3	2	792.411.35	792.410.35	
430 x 35 x 3	2		792.430.35	
450 x 35 x 3	2	792.451.35	792.450.35	
500 x 35 x 3	2	792.501.35	792.500.35	
510 x 35 x 3	2	792.511.35	792.510.35	
520 x 35 x 3	2	792.521.35	792.520.35	
530 x 35 x 3	2	792.531.35	792.530.35	
550 x 35 x 3	2	792.551.35		
600 x 35 x 3	2	792.601.35	792.600.35	
610 x 35 x 3	2	792.611.35	792.610.35	
630 x 35 x 3	2	792.631.35	792.630.35	
650 x 35 x 3	2	792.651.35		
710 x 35 x 3	2		792.710.35	
810 x 35 x 3	2	792.811.35	792.810.35	
820 x 35 x 3	2	792.821.35		
1070 x 35 x 3	2	792.998.35	792.997.35	

REMARK: special dimensions available on request.

The mirror finish on the HW knives produce cutting edge that is both razor sharp yet extremely durable.

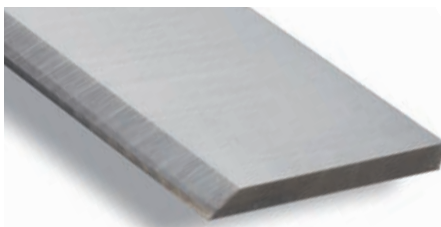

**Reversible knives for portable planers**

**790**

Sizes L H K mm			Machine	Model machine	ORDER NO. HWM
56,0 x 5,5 x 1,1			Adler		790.560.00
60,0 x 5,5 x 1,1			Wegoma		790.600.01
75,5 x 5,5 x 1,1			Aeg	HTH75	790.755.00
			Black & Decker	DN75, 750SR, 600K	
			Bosch	0590, P400, 1590,1591	
			Festo	REP75	
			Haffner	FH222	
			Holz-Her	2223, 2286, 2320	
			Kress	Jet-Star 6701, 6702	
			Mafell	HU75	
			Metabo	6375	
			Scheer	MH75/3, MH80	
			Skil	98H	
78,0 x 5,5 x 1,1			Virutex		790.780.00 790.780*
80,5 x 5,9 x 1,2			Elu	MFF40, MFF80, MFF81, MFF81EK, PF161	790.805.00
80,5 x 5,5 x 1,1			Elu	MFF80	790.805.01
			Aeg		790.805*
			Bosch		
			Haffner		
82,0 x 5,5 x 1,1			Aeg	EH82, EH825, EH822, EH450, EH700, EH82-1, H500, H750, EH700R	790.820.00 790.820*
			Black & Decker	DN76	
			Bosch	PHO 100/150, PHO 200/300 4387, PHO 2-82/3-82, Gustav, H00882	
			Casals	CE82	
			DeWalt	DW678, DW678EK, DW680	
			Elu	HH15, HH40, HH40K, HH40EK	
			Fein	HS2151	
			Felisatti	TP282	
			Haffner	FH224	
			Hitachi	F20, F20A, FP20A, P20V, P20SA	
			Holz-Her	2321, 2322	
			Legna	R82, G82	
			Mafell	EHU82, MHU82	
			Makita	1001, 1100, 1125B, 1900B, 1901, 1923B, 1923H, 1923HO	
			Metabo	4382, 8382, 0882, 0883, E0983	
			Perless	HHB82B	
			Peugeot	RA400, 82RAC, RA82CS, BR82 BRA1-82, BRA3-82, RA1082CA	
			Ryobi	L1323-A	
			Skil	H92, H94, H95, H96, H97 1506, 1510	
			Stayer	980B	
82,7 x 5,5 x 1,1			Black & Decker	DN710, DN712, DN730, DN71-02, DN71-03, BD711	790.827.00
92,0 x 5,5 x 1,1			Aeg	450	790.920.00
			Hitachi	F30A, FU30	
			Ryobi	L120N, L150N, L1205N, L1323	
102,0 x 5,5 x 1,1			Aeg	HB750, EH102, HBE800	790.992.00

**TECHNICAL DETAILS:**

- Order no. ISO: . . . . . K40
- Hardness (HV10): . . . . . 1.400
- Transverse rupture strength (N/mm<sup>2</sup>): . 2.600

**APPLICATION:**

- Soft wood . . . . . Good
- Hard wood . . . . . Suitable
- Plywood . . . . . Suitable

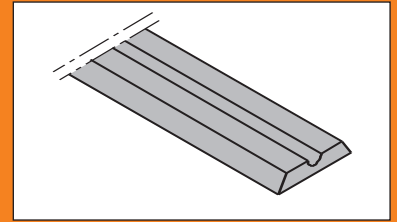

10-PCS. CASE

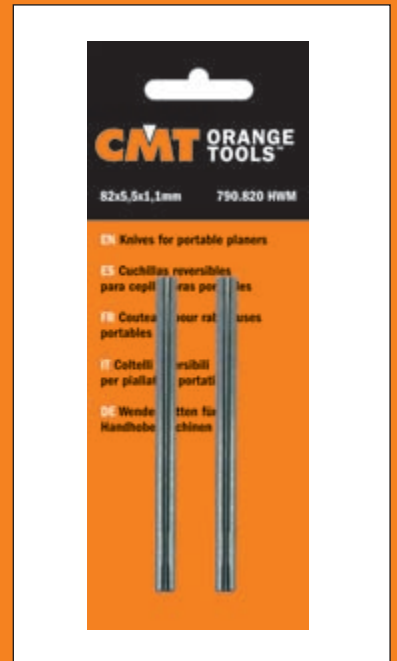

\*2-PCS. BLISTER CASE



10-PCS. CASE



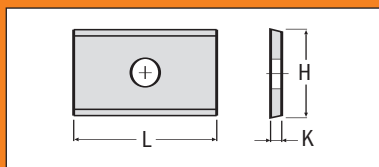

Standard reversible knives 2 cutting edges 35°

790

Sizes mm L H K	ORDER NO.			
	HC	MG	SMG	UMG
7,5 x 12 x 1,5	790.075.00			
7,65 x 12 x 1,5	790.076.00			
9,6 x 12 x 1,5	790.096.00			
15 x 12 x 1,5	790.150.00			
20 x 12 x 1,5	790.200.00	790.200.02	790.200.03	

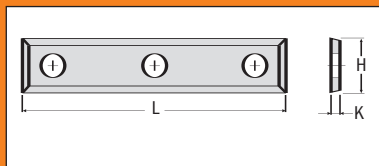

Standard reversible knives 2 cutting edges 35°

790

Sizes mm L H K	ORDER NO.			
	HC	MG	SMG	UMG
25 x 12 x 1,5	790.250.00			
30 x 12 x 1,5	790.300.00	790.300.02	790.300.03	790.300.04
40 x 12 x 1,5	790.400.00	790.400.02	790.400.03	
50 x 12 x 1,5	790.500.00	790.500.02	790.500.03	790.500.04
60 x 12 x 1,5	790.600.00		790.600.03	

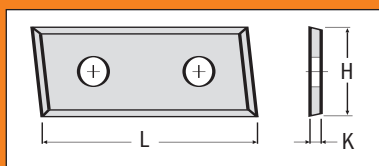

Standard reversible knives 4 cutting edges 35°

790

Sizes mm L H K	ORDER NO.			
	HC	MG	SMG	UMG
28,3 x 12 x 1,5	790.283.12			
48,3 x 12 x 1,5	790.483.12			

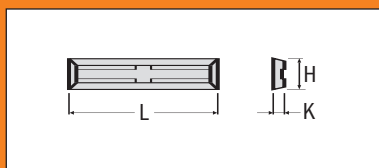

Standard reversible knives 4 cutting edges 35°

790

Sizes mm L H K	ORDER NO.			
	HC	MG	SMG	UMG
20 x 4,1 x 1,1	790.200.01			
30 x 5,5 x 1,1	790.300.01			
50 x 5,5 x 1,1	790.500.01			

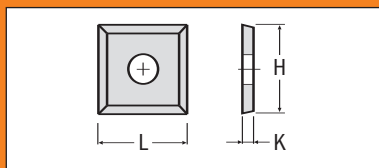

Standard reversible knives 4 cutting edges 35°

790

Sizes mm L H K	ORDER NO.			
	HC	MG	SMG	UMG
12 x 12 x 1,5	790.120.00	790.120.02	790.120.03	
14 x 14 x 1,2	790.140.10			
14 x 14 x 2	790.140.00	790.140.02	790.140.03	

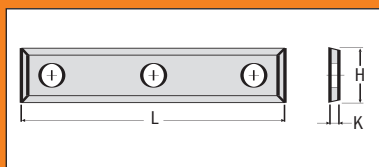

Standard reversible knives 4 cutting edges 35°

790

Sizes mm L H K	ORDER NO.			
	HC	MG	SMG	UMG
50 x 9 x 1,5	790.500.09			

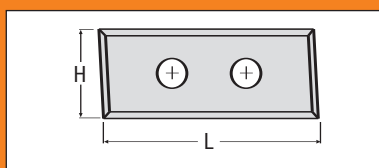

Standard reversible knives 4 cutting edges 35°

790

Sizes mm L H K	ORDER NO.			
	HC	MG	SMG	UMG
29,5 x 9 x 1,5	790.295.09			
29,5 x 12 x 1,5	790.295.12			
49,5 x 9 x 1,5	790.495.09			
49,5 x 12 x 1,5	790.495.12			

**Special reversible knives 2 cutting edges 35°**

**790**

Sizes mm L H K	ORDER NO.			
	HC	MG	SMG	UMG
20 x 12 x 1,5	790.201.00			
30 x 12 x 1,5	790.301.00			
50 x 12 x 1,5	790.501.00			

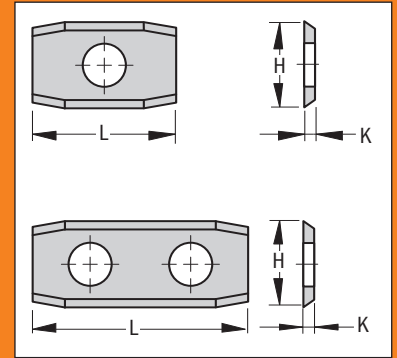

**Standard reversible knives 4 cutting edges 35°**

**790**

Sizes mm L H K	ORDER NO.			
	HC	MG	SMG	UMG
18 x 18 x 2	790.181.00			
18 x 18 x 2,5	790.182.00			

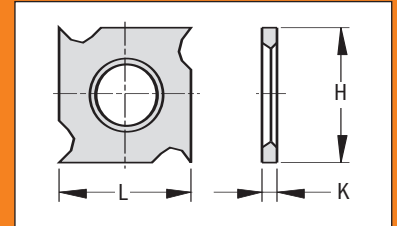

**Standard reversible knives 35°**

**790**

Sizes mm L H K	ORDER NO.			
	HC	MG	SMG	UMG
22 x 19 x 2	790.220.02			

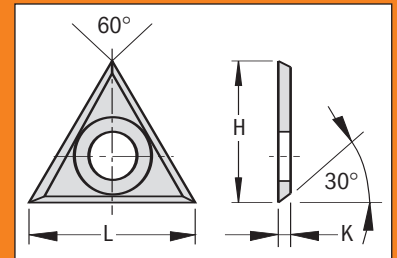

**Edge rounding reversible knives 35°**

**790**

Sizes mm L H K	ORDER NO.			
	HC	MG	SMG	UMG
R 1,5 16 x 22 x 5	790.161.00			
R 2 16 x 22 x 5	790.162.00			
R 3 16 x 22 x 5	790.163.00			
45° 16 x 22 x 5	790.160.00			

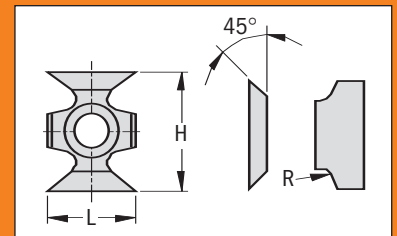

**Profiled rounding reversible knives 4 cutting edges 35°**

**790**

Sizes mm L H K	ORDER NO.			
	HC	MG	SMG	UMG
R 2 19,5 x 9 x 1,5	790.020.00			
R 3 19,5 x 9 x 1,5	790.030.00			
R 5 19,5 x 9 x 1,5	790.050.00			
R 6,4 24 x 12 x 1,5	790.064.00			
R 8 24 x 12 x 1,5	790.080.00			

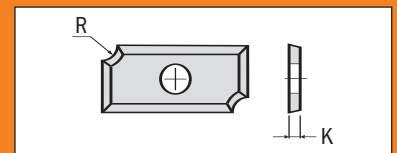

**TECHNICAL DETAILS:**

All knives supplied in 10 pcs. case.

- HC** Hardness (HV10): 1.760 - Transverse rupture strength (N/mm²): 2.100
- MG** Hardness (HV10): 1.680 - Transverse rupture strength (N/mm²): 3.700
- SMG** Hardness (HV10): 2.300 - Transverse rupture strength (N/mm²): 3.500
- UMG** Hardness (HV10): 2.550 - Transverse rupture strength (N/mm²): 3.200

MATERIAL	HC	MG	SMG	UMG
Dry Softwood	1			
Wet Softwood	1			
Dry Hardwood	1	1		
Wet Hardwood	1	1		
Chipboard		1	1	1
MDF		1	1	1
HDF			1	1







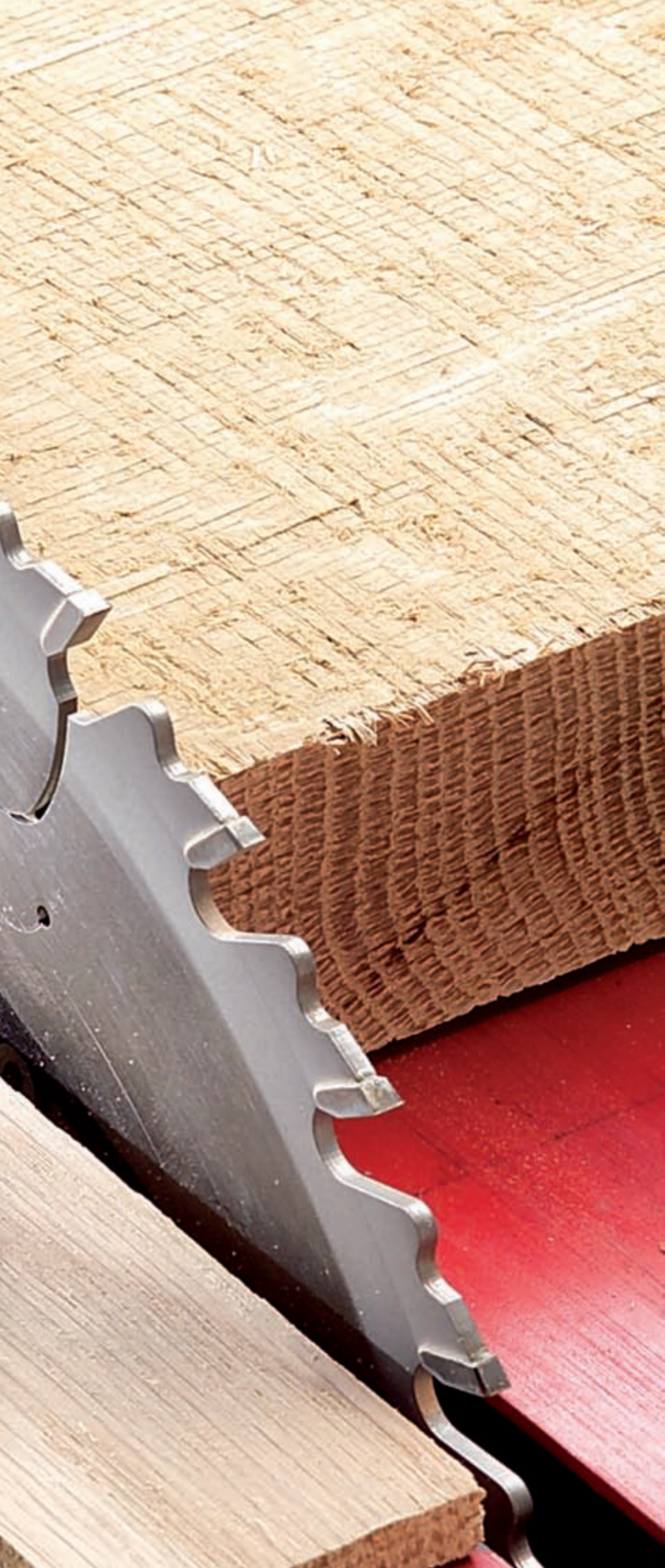

## Saw blades



Multi-rip saw blade with/without rakers 160



Saw blade for building contractor 161



Ripping and crosscut 162



Fine cut off saw blade for melamine 164



Scoring 167



Laminated and chipboard 169



Non-ferrous, alu and PVC 171



Ultra industrial thin-kerf "ULTRA ITK" 174



For portable machines 177



- ALWAYS** thoroughly check all blades for damage and flaws before using. Do not use blades with missing or damaged teeth.
- ALWAYS** wear safety glasses and ear protection when using power tools.
- ALWAYS** thoroughly read the owners manual and manufacturer's instructions before working with tools.
- ALWAYS** use a fence and splitter when using the table saw. Do not make freehand cuts.
- ALWAYS** use pusher blocks or a pusher stick, especially when working with small or narrow pieces.
- ALWAYS** unplug your saw before cleaning or adjusting the tool, or before making blade changes.
- ALWAYS** keep your tools sharpened, clean and stored in a safe place to avoid breakage and accidents and to extend the life of your bits and blades.
- ALWAYS** feed the work against the rotation of the blade on table saws.
- ALWAYS** be sure your workpiece is completely supported, before and after the cut.
- NEVER** remove guards from radial arm saws and miter saws.
- NEVER** remove the splitter or anti-kickback devices from table saws.
- NEVER** use dull or damaged blades.
- NEVER** use blades with missing or chipped teeth.
- NEVER** force the cut or overload the saw.
- NEVER** change blades with the saw plugged in.
- NEVER** make adjustments to any saw while the blade is turning.

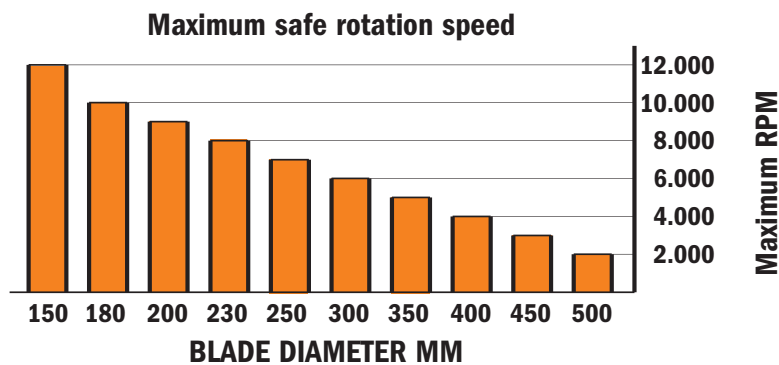

## Legenda

- $\alpha$  = Hook angle
- ATB** = Alternate top bevel grind
- $\beta$  = Type of grind
- COMBI3** = Pin-Hole 2/7/42 + 2/9/46 + 2/10/60
- D** = Blade diameter
- d** = Small cutting diameter
- F** = Bore diameter
- FTG** = Flat top grind
- HDF** = Hollow ground teeth
- K** = Kerf thickness
- mm** = Millimeters
- P** = Plate thickness
- PTFE** = Non-stick industrial coating, black and orange
- TCG** = Triple chip grind (trapezoidal)
- V** = Spurs
- Z** = Number of teeth



Tungsten carbide tipped



Anti-kickback design



Low noise



Cardboard box for saw blades



Plastic carry case for saw blades

280



A new saw blade with alternate teeth and special rakers for ripping cuts in solid wood, dry and wet. The tungsten carbide rakers prevent the sides of the wood from making contact with the steel plate. Ideal for use on square cut machine (multi or single blade) and single or double spindle circular saw machines.

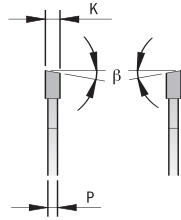
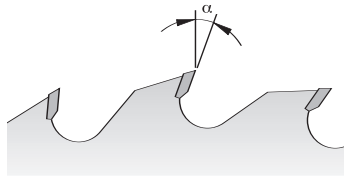

**TECHNICAL DETAILS OF CARBIDE TEETH:**

- Teeth height mm: 10
- Order no. ISO: K20
- Hardness (HV10): 1.640
- Transverse rupture strength (N/mm<sup>2</sup>): 2.200

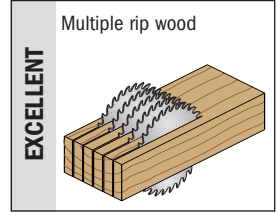

D Blade diameter mm	F Bore diameter mm	Key way mm	Z No. of teeth	K Kerf thickness mm	P Plate thickness mm	α Hook angle	β Type of grind	ORDER NO.
180	40		21+3	2,5	1,8	20°	FLAT	<b>280.021.07S</b>
200	40		21+3	2,5	1,8	20°	FLAT	<b>280.021.08S</b>
250	70	21 x 5	20+4	2,7	1,8	20°	5° ATB	<b>280.020.10V</b>
250	80	13 x 5	20+4	2,7	1,8	20°	5° ATB	<b>280.020.10W</b>
300	70	21 x 5	24+4	2,7	1,8	20°	5° ATB	<b>280.024.12V</b>
300	80	13 x 5	24+4	2,7	1,8	20°	5° ATB	<b>280.024.12W</b>

new

**Thick Kerf multi-rip saw blades with rakers**  
industrial line

277



A new saw blade with alternate teeth and special rakers for ripping cuts in solid wood, dry and wet with humidity rate over 10%. And with a high resin content. The tungsten carbide rakers prevent the sides of the wood from making contact with the steel plate. Ideal for use on sawmills on square cut machine (multi or single blade) and single or double spindle circular saw machines.

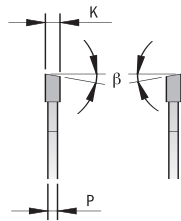
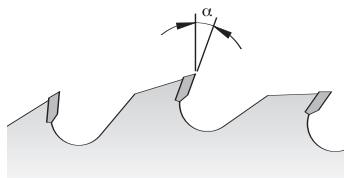

**TECHNICAL DETAILS OF CARBIDE TEETH:**

- Order no. ISO: K20
- Hardness (HV10): 1.640
- Transverse rupture strength (N/mm<sup>2</sup>): 2.200

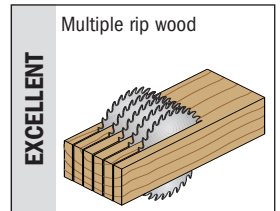

D Blade diameter mm	F Bore diameter mm	Key way mm	Z No. of teeth	K Kerf thickness mm	P Plate thickness mm	α Hook angle	β Type of grind	ORDER NO.
300	30		24+4	4,0	2,8	18°	10° ATB	<b>277.024.12M</b>
300	70	21 x 5	24+4	4,0	2,8	18°	10° ATB	<b>277.024.12V</b>
300	80	13 x 5	24+4	4,0	2,8	18°	10° ATB	<b>277.024.12W</b>
350	30		24+6	4,2	2,8	18°	10° ATB	<b>277.024.14M</b>
350	70	21 x 5	24+6	4,2	2,8	18°	10° ATB	<b>277.024.14V</b>



**279**



A new saw blade with alternate teeth and special rakers for ripping cuts in solid wood, dry and wet. The tungsten carbide rakers prevent the sides of the wood from making contact with the steel plate. Ideal for use on square cut machine (multi or single blade) and single or double spindle circular saw machines.

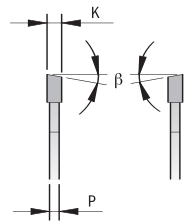
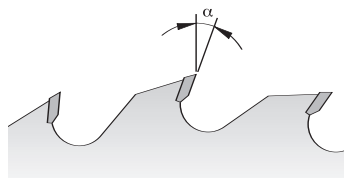

**TECHNICAL DETAILS OF CARBIDE TEETH:**

- Teeth height mm: 10
- Order no. ISO: K20
- Hardness (HV10): 1.640
- Transverse rupture strength (N/mm<sup>2</sup>): 2.200

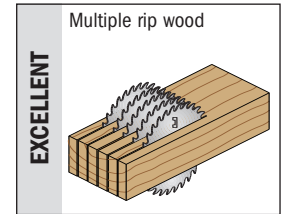

D Blade diameter mm	F Bore diameter mm	Key way mm	Z No. of teeth	K Kerf thickness mm	P Plate thickness mm	α Hook angle	β Type of grind	ORDER NO.
250	30		20+4	3,2	2,2	20°	5° ATB	<b>279.020.10M</b>
250	70	21 x 5	20+4	3,2	2,2	20°	5° ATB	<b>279.020.10V</b>
250	80	13 x 5	20+4	3,2	2,2	20°	5° ATB	<b>279.020.10W</b>
300	30		24+4	3,2	2,2	20°	5° ATB	<b>279.024.12M</b>
300	60	21 x 5	24+4	3,2	2,2	20°	5° ATB	<b>279.024.12U</b>
300	70	21 x 5	24+4	3,2	2,2	20°	5° ATB	<b>279.024.12V</b>
300	80	13 x 5	24+4	3,2	2,2	20°	5° ATB	<b>279.024.12W</b>
350	30		28+4	3,5	2,5	20°	5° ATB	<b>279.028.14M</b>
350	60	21 x 5	28+4	3,5	2,5	20°	5° ATB	<b>279.028.14U</b>
350	70	21 x 5	28+4	3,5	2,5	20°	5° ATB	<b>279.028.14V</b>
350	80	14 x 5	28+4	3,5	2,5	20°	5° ATB	<b>279.028.14W</b>
400	30		28+6	4	2,8	20°	5° ATB	<b>279.028.16M</b>
400	70	21 x 5	28+6	4	2,8	20°	5° ATB	<b>279.028.16V</b>

**Multi-rip saw blades**  
industrial line



**278**



A new saw blade with alternate teeth and special steel body for ripping cuts in solid wood, dry and wet. The special steel body prevent vibrations and grant perfect cuts of the wood. Ideal for use on square cut machine (multi or single blade) and single or double spindle circular saw machines.

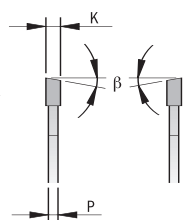
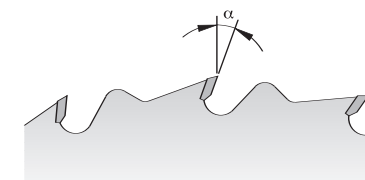

**TECHNICAL DETAILS OF CARBIDE TEETH:**

- Teeth height mm: 10
- Order no. ISO: K20
- Hardness (HV10): 1.640
- Transverse rupture strength (N/mm<sup>2</sup>): 2.200

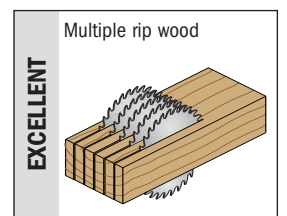

D Blade diameter mm	F Bore diameter mm	Key way mm	Z No. of teeth	K Kerf thickness mm	P Plate thickness mm	α Hook angle	β Type of grind	ORDER NO.
300	30		28	3,2	2,2	20°	5° ATB	<b>278.028.12M</b>
300	70	21x5	28	3,2	2,2	20°	5° ATB	<b>278.028.12V</b>
350	30		36	3,5	2,5	20°	5° ATB	<b>278.036.14M</b>
350	70	21x5	36	3,5	2,5	20°	5° ATB	<b>278.036.14V</b>



**286**



The 5° alternate sharpening and the special carbide, make the CMT building contractors blades ideal for cuts in soft wood with nails, screws and concrete. Perfect for your miter and table saws, manual feeding with low feed rate force.

Equipped with pin holes suitable for the most popular machines.

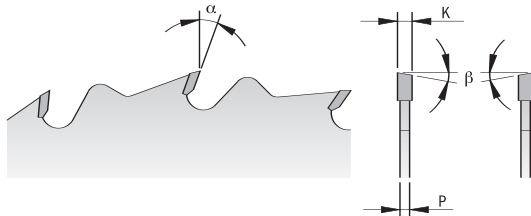
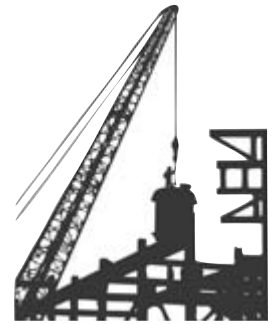

**TECHNICAL DETAILS OF CARBIDE TEETH:**

- Teeth height mm: 6~10
- Order no. ISO: K20
- Hardness (HV10): 1.550
- Transverse rupture strength (N/mm<sup>2</sup>): 2.600

**EXCELLENT**

Soft wood with nails, screw, concrete, etc.

D Blade diameter mm	F Bore diameter mm	Pin hole 	Z No. of teeth	K Kerf thickness mm	P Plate thickness mm	α Hook angle	β Type of grind	ORDER NO.
250	30	COMBI3	16	2,8	1,8	15°	5° ATB	<b>286.016.10M</b>
300	30	COMBI3	20	2,8	1,8	15°	5° ATB	<b>286.020.12M</b>
315	30	COMBI3	24	3,2	2,2	15°	5° ATB	<b>286.024.13M</b>
350	30	COMBI3	24	3,2	2,2	15°	5° ATB	<b>286.024.14M</b>
400	30	COMBI3	28	3,2	2,2	15°	5° ATB	<b>286.028.16M</b>
450	30	2/10/60	32	3,8	2,8	15°	5° ATB	<b>286.032.18M</b>
500	30	2/10/60	36	3,8	2,8	15°	5° ATB	<b>286.036.20M</b>
550	30	2/10/60	40	4	3	15°	5° ATB	<b>286.040.22M</b>
600	30	2/10/60	40	4	3	15°	5° ATB	<b>286.040.24M</b>

**Shop tips:**

Use our reduction rings from 30 to 25mm order no. 299.225.00 (for saw blades Ø250-300-315)  
Use our reduction rings from 30 to 25mm order no. 299.228.00 (for saw blades Ø350 and more)

**Ripping saw blades**  
*industrial line*



**285-290**  
**293**



Alternate top bevel ground teeth, a low number of teeth and a 20° hook angle make the CMT rip blade ideal for glue line rips in hard and soft woods. Ideal for automatic and manual feeding with low feed rate force. Equipped with pin holes suitable for the most popular machines.

**TECHNICAL DETAILS OF CARBIDE TEETH:**

- Teeth height mm: 8~10
- Order no. ISO: K10
- Hardness (HV10): 1.765
- Transverse rupture strength (N/mm<sup>2</sup>): 2.150

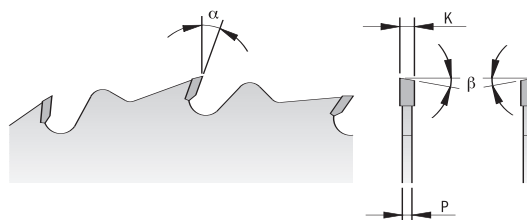

**EXCELLENT**

Rip wood

\* Non-low noise

D Blade diameter mm	F Bore diameter mm	Pin hole 	Z No. of teeth	K Kerf thickness mm	P Plate thickness mm	α Hook angle	β Type of grind	ORDER NO.
250*	30	COMBI3	24	2,8	1,8	20°	10° ATB	<b>290.250.24M</b>
270*	30	2/7/42	28	2,8	1,8	15°	10° ATB	<b>290.270.28M</b>
300	30	COMBI3	24	3,2	2,2	20°	10° ATB	<b>293.024.12M</b>
305	30	2/10/60	28	2,8	1,8	20°	10° ATB	<b>293.028.22M</b>
315*	30	COMBI3	28	3,2	2,2	20°	10° ATB	<b>293.028.12M</b>
350	30	COMBI3	28	3,5	2,5	20°	10° ATB	<b>293.028.14M</b>
400	30	COMBI3	36	3,5	2,5	20°	10° ATB	<b>285.036.16M</b>
450	30	2/10/60	36	3,8	2,8	20°	10° ATB	<b>285.036.18M</b>





**285-291**  
**294**



Get the speed and efficiency you need with its 15° or 20° hook angle and medium number of teeth. Whether ripping or cross cutting you can work a wide range of materials, like soft, hard woods and plywood, with accuracy and efficiency. Equipped with pin holes suitable for most popular machines. A must for professional woodworkers.

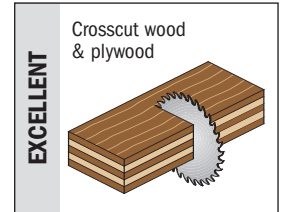
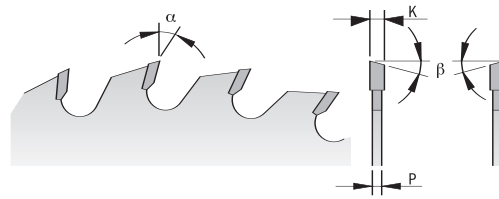

**TECHNICAL DETAILS OF CARBIDE TEETH:**

- Teeth height mm: 8~10
- Order no. ISO: K10
- Hardness (HV10): 1.765
- Transverse rupture strength (N/mm<sup>2</sup>): 2.150

D Blade diameter mm	F Bore diameter mm	Pin hole 	Z No. of teeth	K Kerf thickness mm	P Plate thickness mm	α Hook angle	β Type of grind	ORDER NO.
200*	30	2/10/60 + 2/7/42	36	3,2	2,2	15°	10° ATB	<b>285.036.08M</b>
250	20	COMBI3	40	3,2	2,2	15°	10° ATB	<b>285.040.10H</b>
250	30	COMBI3	40	3,2	2,2	15°	10° ATB	<b>285.040.10M</b>
250*	35		40	3,2	2,2	15°	10° ATB	<b>285.040.10R</b>
260	30	2/10/60 + 2/7/42	48	3,2	2,2	15°	10° ATB	<b>285.048.11M</b>
270	30	2/7/42	42	2,8	1,8	15°	15° ATB	<b>291.270.42M</b>
275	20		42	3,2	2,2	15°	10° ATB	<b>285.042.11H</b>
300	20	COMBI3	48	3,2	2,2	15°	10° ATB	<b>285.048.12H</b>
300	30	COMBI3	48	3,2	2,2	15°	10° ATB	<b>285.048.12M</b>
300*	35		48	3,2	2,2	15°	10° ATB	<b>285.048.12R</b>
315*	30	2/10/60 + 2/7/42	36	3,2	1,8	15°	10° ATB	<b>285.036.13M</b>
350	30	COMBI3	54	3,5	2,5	15°	10° ATB	<b>285.054.14M</b>
350*	35		54	3,5	2,5	15°	10° ATB	<b>285.054.14R</b>
400	30	COMBI3	48	3,5	2,5	20°	10° ATB	<b>285.048.16M</b>



**285-294**



THE all-around cut off blade for hardwood, softwood, plywood, chipboard and MDF. The alternate top bevel teeth, 10° or 15° hook angle and high tooth count make this blade perfect for use on all your professional machines. With the ultimate fishhook expansion design your blade runs smoother and works more efficiently.

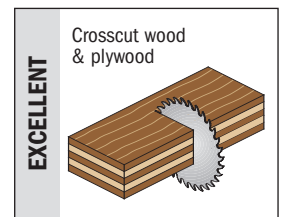
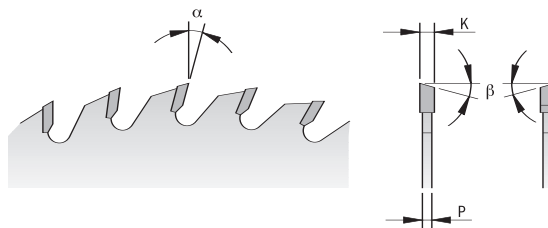

**TECHNICAL DETAILS OF CARBIDE TEETH:**

- Teeth height mm: 10
- Order no. ISO: K01
- Hardness (HV10): 1.840
- Transverse rupture strength (N/mm<sup>2</sup>): 2.050

\* Non-low noise

D Blade diameter mm	F Bore diameter mm	Pin hole 	Z No. of teeth	K Kerf thickness mm	P Plate thickness mm	α Hook angle	β Type of grind	ORDER NO.
200*	30	2/10/60 + 2/7/42	48	3,2	2,2	15°	15° ATB	<b>285.048.08M</b>
250	30	COMBI3	48	3,2	2,2	15°	10° ATB	<b>285.048.10M</b>
250	30	COMBI3	60	3,2	2,2	10°	15° ATB	<b>285.060.10M</b>
250*	35		60	3,2	2,2	10°	15° ATB	<b>285.060.10R</b>
260	30	2/10/60 + 2/7/42	60	3,2	2,2	10°	15° ATB	<b>285.060.11M</b>
280*	30	2/10/60 + 2/7/42	64	2,8	1,8	10°	15° ATB	<b>295.064.11M</b>
300	30	COMBI3	60	3,2	2,2	15°	10° ATB	<b>285.060.12M</b>
300	30	COMBI3	72	3,2	2,2	10°	15° ATB	<b>285.072.12M</b>
300*	35		72	3,2	2,2	10°	15° ATB	<b>285.072.12R</b>
305*	30	2/10/60 + 2/7/42	54	2,8	1,8	-5° Neg.	15° ATB	<b>294.054.22M</b>
315*	30	COMBI3	54	3,2	1,8	15°	10° ATB	<b>294.054.12M</b>
350	30	COMBI3	72	3,5	2,5	15°	10° ATB	<b>285.072.14M</b>
350	30	COMBI3	84	3,5	2,5	10°	15° ATB	<b>285.084.14M</b>
350*	35		84	3,5	2,5	10°	15° ATB	<b>285.084.14R</b>
400*	30	COMBI3	60	3,5	2,5	10°	15° ATB	<b>285.060.16M</b>
450*	30	2/10/60	66	3,8	2,8	10°	15° ATB	<b>285.066.18M</b>
500*	30	2/10/60	72	3,8	2,8	10°	15° ATB	<b>285.072.20M</b>



285



Designed to guarantee high performance on the most popular industrial machines, these blades are ideal for cutting all types of materials such as hard and soft woods, plywood, chipboard and MDF. The alternate grind, the expansion slots made by laser, as well as the high number of teeth, make these blades a tool of sure success for a perfect finish on your project.

**TECHNICAL DETAILS OF CARBIDE TEETH:**

- Teeth height mm: 8
- Order no. ISO: K01F
- Hardness (HV10): 1.950
- Transverse rupture strength (N/mm<sup>2</sup>): 2.300

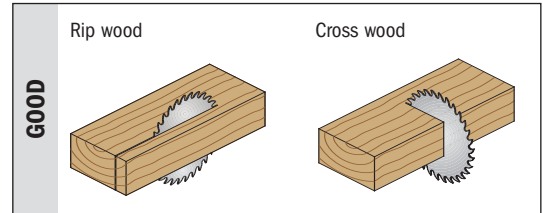
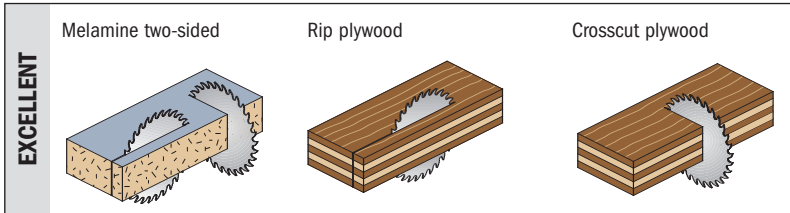
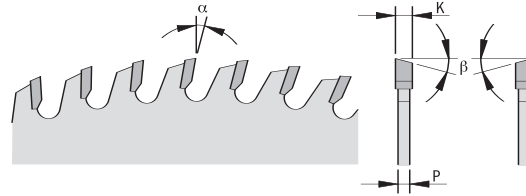

D Blade diameter mm	F Bore diameter mm	Pin hole	Z No. of teeth	K Kerf thickness mm	P Plate thickness mm	$\alpha$ Hook angle	$\beta$ Type of grind	ORDER NO.
150	30	2/7/42	48	3,2	2,2	5°	15° ATB	285.048.06M
180	30	2/7/42	56	3,2	2,2	5°	15° ATB	285.056.07M
200	30	2/10/60 + 2/7/42	64	3,2	2,2	5°	15° ATB	285.064.08M
250	30	COMBI3	80	3,2	2,2	5°	15° ATB	285.080.10M
250	35		80	3,2	2,2	5°	15° ATB	285.080.10R
300	30	COMBI3	96	3,2	2,2	5°	15° ATB	285.096.12M
300	35		96	3,2	2,2	5°	15° ATB	285.096.12R
305	30	2/10/60 + 2/7/42	72	3,2	2,2	10°	15° ATB	285.072.22M
315	30	2/10/60 + 2/7/42	72	3,2	2,2	15°	15° ATB	285.072.13M
350	30	COMBI3	108	3,5	2,5	5°	15° ATB	285.108.14M
350	35		108	3,5	2,5	5°	15° ATB	285.108.14R
400	30	COMBI3	96	3,5	2,5	10°	15° ATB	285.096.16M
400	30	2/10/60 + 2/7/42	120	3,5	2,5	10°	15° ATB	285.120.16M

new

**Super finishing saw blade for frames cut**  
XTreme line



285



Designed to guarantee high performance for an excellent and clean cut of wooden frame. Good finish even cross cutting at 45°. Improved design with double side grind and P.T.F.E. non-stick coating.

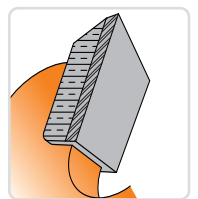

**XTreme Performance!**

**TECHNICAL DETAILS OF CARBIDE TEETH:**

- Teeth height mm: 8
- Order no. ISO: K01F
- Hardness (HV10): 1.950
- Transverse rupture strength (N/mm<sup>2</sup>): 2.300

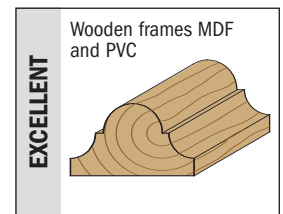
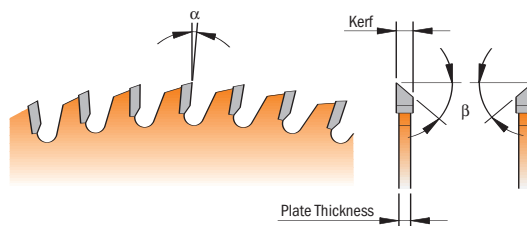

D Blade diameter mm	F Bore diameter mm	Pin hole	Z No. of teeth	K Kerf thickness mm	P Plate thickness mm	$\alpha$ Hook angle	$\beta$ Type of grind	ORDER NO.
250	30	COMBI3	80	3,0	2,5	10°	20° ATB	285.580.10M
300	30	COMBI3	96	3,0	2,5	10°	20° ATB	285.596.12M

Orange PTFE coated blades: a great choice for the shop that keeps its blades running all day, every day. With their heavy-gauge plate, these blades have the stamina for saws with lots of power.



**283**



The ultimate in finish blades! CMT puts a 40° top tooth angle on its blades to provide flawless finishing on single and double laminates, melamine, hard and soft wood - this means absolutely minimal chipping on double faced material! The use of melamine and fine cut off is excellent on large miter saws for complex angle cuts where accuracy is a must.

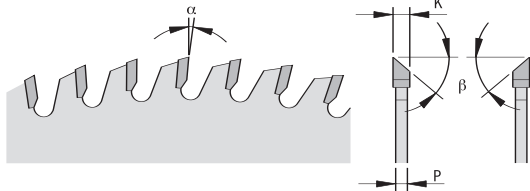

**TECHNICAL DETAILS OF CARBIDE TEETH:**

- Teeth height mm: 8
- Order no. ISO: K01F
- Hardness (HV10): 1.950
- Transverse rupture strength (N/mm<sup>2</sup>): 2.300

<b>EXCELLENT</b>	Cross wood	Crosscut plywood	Melamine two-sided
<b>GOOD</b>	Rip wood	Rip plywood	

D Blade diameter mm	F Bore diameter mm	Pin hole 	Z No. of teeth	K Kerf thickness mm	P Plate thickness mm	α Hook angle	β Type of grind	ORDER NO.
220*	30	2/7/42	64	3,2	2,2	-5°	40° ATB	<b>283.064.09M</b>
250	30	COMBI3	80	3,2	2,2	-2°	40° ATB	<b>283.080.10M</b>
300	30	COMBI3	96	3,2	2,2	2°	40° ATB	<b>283.096.12M</b>
350	30	COMBI3	108	3,5	2,5	5°	40° ATB	<b>283.108.14M</b>

\* Non-low noise

**Fine cut off saw blades for melamine two-sided**  
XTreme line



**210**



The ultimate in finish blade! CMT puts a 40° top tooth angle on its blades to provide flawless finishing on single and double laminates, melamine, hard and soft wood - this means absolutely minimal chipping on double faced material! The use of melamine and fine cut off is excellent on large miter saws for complex angle cuts where accuracy is a must.

**XTreme Performance!**

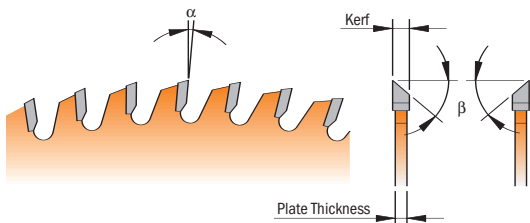

**TECHNICAL DETAILS OF CARBIDE TEETH:**

- Teeth height mm: 8
- Order no. ISO: K01F
- Hardness (HV10): 1.950
- Transverse rupture strength (N/mm<sup>2</sup>): 2.300

<b>EXCELLENT</b>	Cross wood	Plywood	Melamine two-sided

D Blade diameter mm	F Bore diameter mm	Z No. of teeth	K Kerf thickness mm	P Plate thickness mm	α Hook angle	β Type of grind	ORDER NO.
250	30	80	3,2	2,2	5°	40° ATB	<b>210.080.10M</b>
300	30	96	3,2	2,2	5°	40° ATB	<b>210.096.12M</b>

Orange PTFE coated blades: a great choice for the shop that keeps its blades running all day, every day. With their heavy-gauge plate, these blades have the stamina for saws with lots of power.



**281**



A new blade with trapezoidal tooth and special expansion slot cuts which will allow you to make a good crosscut on all kinds of wood and plywood.  
Very good performance guaranteed on laminates, chipboard and 2-sided melamine (using scoring blades).

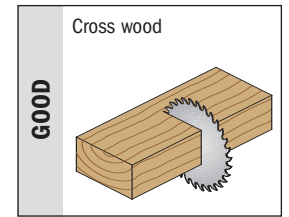
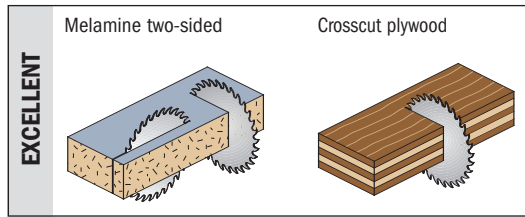

**TECHNICAL DETAILS OF CARBIDE TEETH:**

- Teeth height mm: 8
- Order no. ISO: K01F
- Hardness (HV10): 1.950
- Transverse rupture strength (N/mm<sup>2</sup>): 2.300

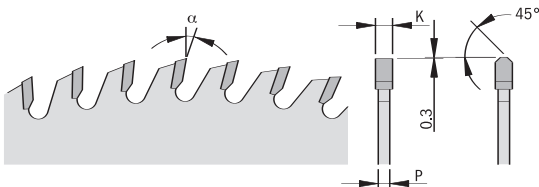
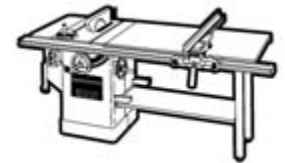

D Blade diameter mm	F Bore diameter mm	Pin hole 	Z No. of teeth	K Kerf thickness mm	P Plate thickness mm	α Hook angle	β Type of grind	ORDER NO.
<b>new</b> 160**	20	4/7/32 45°	40	2,4	1,6	10°	TCG	<b>281.160.40H</b>
200*	30	2/7/42	64	3,2	2,2	10°	TCG	<b>281.064.08M</b>
220*	30	2/7/42	64	3,2	2,2	10°	TCG	<b>281.064.09M</b>
250	30	COMBI3	60	3,2	2,2	10°	TCG	<b>281.060.10M</b>
250	30	COMBI3	80	3,2	2,2	10°	TCG	<b>281.080.10M</b>
300	30	COMBI3	72	3,2	2,2	10°	TCG	<b>281.072.12M</b>
300	30	COMBI3	96	3,2	2,2	10°	TCG	<b>281.096.12M</b>
<b>new</b> 350	30	COMBI3	84	3,5	2,5	10°	TCG	<b>281.084.14M</b>
350	30	COMBI3	108	3,5	2,5	10°	TCG	<b>281.108.14M</b>

\* Non-low noise - \*\* Suitable for Virutex machines

**new**

**Fine cut off saw blades for melamine**  
XTreme line



**281**



A new blade with trapezoidal tooth and special expansion slot cuts which will allow you to make a good crosscut on all kinds of wood and plywood.  
Very good performance guaranteed on laminates, chipboard and 2-sided melamine (using scoring blades).

**XTreme Performance!**

**TECHNICAL DETAILS OF CARBIDE TEETH:**

- Teeth height mm: 8
- Order no. ISO: K01F
- Hardness (HV10): 1.950
- Transverse rupture strength (N/mm<sup>2</sup>): 2.300

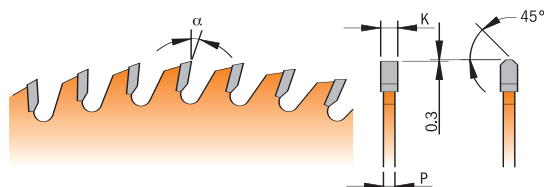
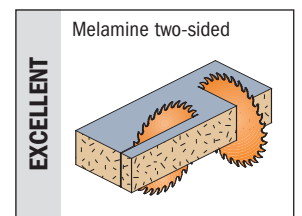

D Blade diameter mm	F Bore diameter mm	Pin hole 	Z No. of teeth	K Kerf thickness mm	P Plate thickness mm	α Hook angle	β Type of grind	ORDER NO.
250	30	COMBI3	80	3,2	2,2	10°	TCG	<b>281.580.10M</b>
300	30	COMBI3	96	3,2	2,2	10°	TCG	<b>281.596.12M</b>
350	30	COMBI3	108	3,5	2,5	10°	TCG	<b>281.608.14M</b>

Orange PTFE coated blades: a great choice for the shop that keeps its blades running all day, every day. With their heavy-gauge plate, these blades have the stamina for saws with lots of power.





281



This new Multi-Purpose blade with trapezoidal tooth and special expansion slots, allow you to make a good crosscut on all kinds of wood and plywood.  
Good performance is guaranteed on laminates and chipboard making the ideal Multi-Purpose blade.

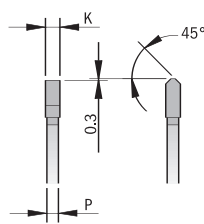
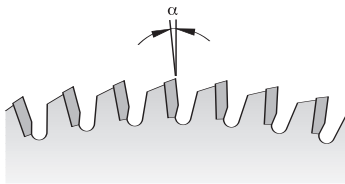
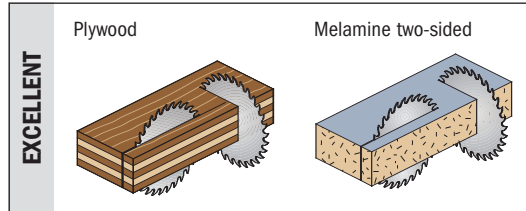

**TECHNICAL DETAILS OF CARBIDE TEETH:**

- Teeth height mm: 10
- Order no. ISO: K01F
- Hardness (HV10): 1.950
- Transverse rupture strength (N/mm<sup>2</sup>): 2.300



D Blade diameter mm	F Bore diameter mm	Pin hole 	Z No. of teeth	K Kerf thickness mm	P Plate thickness mm	α Hook angle	β Type of grind	ORDER NO.
250	30	COMBI3	60	3,2	2,2	-6°	TCG	<b>281.061.10M</b>
300	30	COMBI3	72	3,2	2,2	-6°	TCG	<b>281.073.12M</b>

Fine cut off saw blades for melamine two-sided  
industrial line



287



The new standard saw blades with hollow ground tooth to provide flawless finishing on single and double sided laminated panels and PVC coated panels.  
**Use on table or wall saw (like Striebig and Holz-Her) without the need of the scoring blade.**

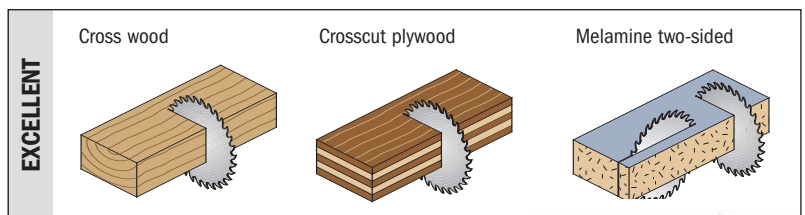

**TECHNICAL DETAILS OF CARBIDE TEETH:**

- Teeth height mm: 8
- Order no. ISO: K01F
- Hardness (HV10): 1.950
- Transverse rupture strength (N/mm<sup>2</sup>): 2.300

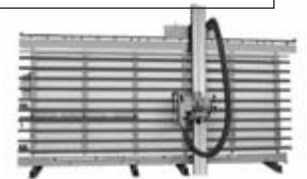
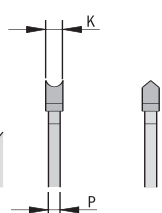
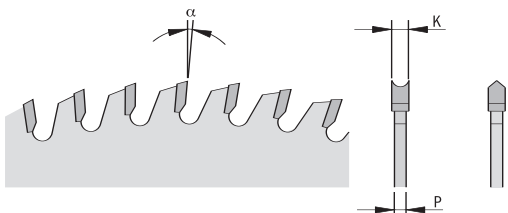

D Blade diameter mm	F Bore diameter mm	Pin hole 	Z No. of teeth	K Kerf thickness mm	P Plate thickness mm	α Hook angle	β Type of grind	ORDER NO.
220	30	2/7/42	42	3,2	2,2	10°	HDF	<b>287.042.09M</b>
250	30	COMBI3	48	3,2	2,2	10°	HDF	<b>287.048.10M</b>
303	30	COMBI3	60	3,2	2,2	10°	HDF	<b>287.060.12M</b>



The scoring blades are essential tools for the cutting industry for melamine and laminated materials. CMT produces 2 types: a conical grind tooth and an adjustable flat tooth with shields. The conical scoring blade will allow you to make different thickness cuts by increasing or decreasing the cutting height.

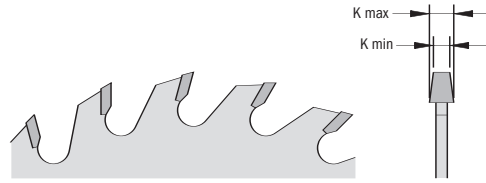

**TECHNICAL DETAILS OF CARBIDE TEETH:**

- Teeth height mm: 8~10
- Order no. ISO: K01F
- Hardness (HV10): 1.950
- Transverse rupture strength (N/mm<sup>2</sup>): 2.300

D Blade diameter mm	F Bore diameter mm	Pin hole 	Z No. of teeth	K Kerf thickness mm		$\beta$ Type of grind	ORDER NO.
100	20		20	3,1-4		CONICAL	<b>288.100.20H</b>
100	22		20	3,1-4		CONICAL	<b>288.100.20K</b>
120	20		24	3,1-4		CONICAL	<b>288.120.24H</b>
120	22		24	3,1-4		CONICAL	<b>288.120.24K</b>
125	20		24	3,1-4		CONICAL	<b>288.125.24H</b>
125	20		24	4,3-5,5		CONICAL	<b>288.125.24H2</b>
125	22		24	3,1-4		CONICAL	<b>288.125.24K</b>
125	45		24	4,3-5,5		CONICAL	<b>288.125.24Q</b>
140	16	1/6/33	24	3,1-4		CONICAL	<b>Y288.140.24E</b>
150	45		36	4,3-5,5		CONICAL	<b>288.150.36Q</b>
160	45	3/11/70	36	4,3-5,5		CONICAL	<b>288.160.36Q</b>
160	55	3/7/66	36	4,3-5,5		CONICAL	<b>288.160.360</b>
160	55	3/7/66	36	4,7-6,0		CONICAL	<b>Y288.160.3602</b>
180	20		36	4,3-5,5		CONICAL	<b>Y288.180.36H</b>
180	30		36	4,3-5,5		CONICAL	<b>288.180.36M</b>
180	45		36	4,7-6,0		CONICAL	<b>288.180.36Q</b>
180	55		36	5,0-6,2		CONICAL	<b>288.180.360</b>
180	50	3/12,5/80	44	4,3-5,5		CONICAL	<b>288.180.44T</b>
200	20		36	4,3-5,5		CONICAL	<b>288.200.36H</b>
200	45		36	4,7-6,0		CONICAL	<b>288.200.36Q</b>
200	65	2/9/110	36	4,3-5,5		CONICAL	<b>288.200.36J</b>
215	50	3/15/80	42	4,3-5,5		CONICAL	<b>288.215.42T</b>
300	50	3/15/80	48	4,3-5,5		CONICAL	<b>288.300.48T</b>
300	65	2/9/110	72	4,3-5,5		CONICAL	<b>288.300.72J</b>

**Adjustable scoring blades**  
industrial line



The flat adjustable scoring blade will allow you to make different thickness cuts by increasing or decreasing number of the shields.

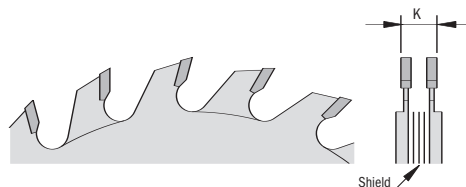

**TECHNICAL DETAILS OF CARBIDE TEETH:**

- Teeth height mm: 7
- Order no. ISO: K01F
- Hardness (HV10): 1.950
- Transverse rupture strength (N/mm<sup>2</sup>): 2.300

D Blade diameter mm	F Bore diameter mm		Z No. of teeth	K Kerf thickness mm		$\beta$ Type of grind	ORDER NO.
80	20		10+10	2,8-3,6		FLAT	<b>289.080.20H</b>
100	20		10+10	2,8-3,6		FLAT	<b>289.100.20H</b>
100	22		10+10	2,8-3,6		FLAT	<b>289.100.20K</b>
120	20		12+12	2,8-3,6		FLAT	<b>289.120.24H</b>
120	22		12+12	2,8-3,6		FLAT	<b>289.120.24K</b>
125	20		12+12	2,8-3,6		FLAT	<b>289.125.24H</b>
125	22		12+12	2,8-3,6		FLAT	<b>289.125.24K</b>

D mm	F mm		Z	K mm	β	ORDER NO. PANEL SIZING SAW BLADE	MACCHINE	D mm	F mm	Z	K mm	ORDER NO. CONICAL SCORING BLADE
<b>ALTENDORF</b>												
300	30	2+2	96	3,2	TCG	<b>281.096.12M</b>	F45, WA80	120	22	24	3,1-4,0	<b>288.120.24K</b>
<b>ANTHON</b>												
400	60	2	72	4,4	TCG	<b>282.072.16U</b>	LN90, LNA100, PORTA100	180	20	36	4,3-5,5	<b>Y288.180.36H</b>
500	60	2	72	4,8	TCG	<b>282.072.20U</b>	PORTA150, LNB150					
<b>CASADEI</b>												
300	30		60	4,4	TCG	<b>282.060.12M</b>	MX, CX, SX, SV	125	20	24	4,3-5,5	<b>288.125.24H2</b>
350	30	4	72	4,4	TCG	<b>282.072.14M</b>	MX, CX, SX, SV	125	20	24	4,3-5,5	<b>288.125.24H2</b>
<b>GABBIANI</b>												
300	80	4+2+2	60	4,4	TCG	<b>282.060.12W</b>	GMS	160	55	36	4,3-5,5	<b>288.160.360</b>
350	80	4+2+2	72	4,4	TCG	<b>282.072.14W</b>	GMS 10-30-40-50	160	55	36	4,3-5,5	<b>288.160.360</b>
400	80	4+2+2	72	4,4	TCG	<b>282.072.16W</b>	GMS 10-30-40-50	160	55	36	4,3-5,5	<b>288.160.360</b>
500	80	4+2+2	72	4,8	TCG	<b>Y282.072.20W</b>		160	55	36	4,7-6,0	<b>Y288.160.3602</b>
<b>GIBEN</b>												
300	75	4	60	4,4	TCG	<b>282.060.12X</b>	FASTMATIC	125	45	24	4,3-5,5	<b>288.125.24Q</b>
350	75	4	72	4,4	TCG	<b>282.072.14X</b>	MK, GAMMA N, ST, SE, TREND, MK2	125	45	24	4,3-5,5	<b>288.125.24Q</b>
400	75	4	72	4,4	TCG	<b>282.072.16X</b>	G2000	125	45	24	4,3-5,5	<b>288.125.24Q</b>
400	75	4	72	4,4	TCG	<b>282.072.16X</b>	PRIMASTIC 101	160	45	36	4,3-5,5	<b>288.160.36Q</b>
400	75	4	72	4,4	TCG	<b>282.072.16X</b>	PRIMASTIC 201	215	50	42	4,3-5,5	<b>288.215.42T</b>
430	75	4	72	4,4	TCG	<b>282.072.17X</b>	PRIMASTIC 201	300	50	48	4,3-5,5	<b>288.300.48T</b>
550	100		72	5,2	TCG	<b>282.072.22A</b>	FASTMATIC	180	55	36	5,0-6,2	<b>288.180.360</b>
<b>HÖFER</b>												
300	30		60	4,4	TCG	<b>282.060.12M</b>	PS	180	20	36	4,3-5,5	<b>Y288.180.36H</b>
350	30	4+2+2	72	4,4	TCG	<b>282.072.14M</b>	PM	200	20	36	4,3-5,5	<b>288.200.36H</b>
400	30		72	4,4	TCG	<b>282.072.16M</b>	PM	200	20	36	4,3-5,5	<b>288.200.36H</b>
<b>HOLZMA</b>												
380	60		72	4,8	TCG	<b>282.072.15U</b>	HPP 81, HPL 81, 91	200	45	36	4,7-6,0	<b>288.200.36Q</b>
450	60		72	4,8	TCG	<b>282.072.18U</b>	HPP 11	180	45	36	4,7-6,0	<b>288.180.36Q</b>
500	60	2	72	4,8	TCG	<b>282.072.20U</b>	TYP 22	200	45	36	4,7-6,0	<b>288.200.36Q</b>
<b>HOMAG</b>												
300	75	4	60	4,4	TCG	<b>282.060.12X</b>	CH03	125	45	24	4,3-5,5	<b>288.125.24Q</b>
300	75	4	60	4,4	TCG	<b>282.060.12X</b>	CH04, CH06/10	150	45	36	4,3-5,5	<b>288.150.36Q</b>
400	75	4	72	4,4	TCG	<b>282.072.16X</b>	CH12	150	45	36	4,3-5,5	<b>288.150.36Q</b>
<b>MAYER</b>												
300	30		60	4,4	TCG	<b>282.060.12M</b>		125	45	24	4,3-5,5	<b>288.125.24Q</b>
350	30	4	72	4,4	TCG	<b>282.072.14M</b>		125	45	24	4,3-5,5	<b>288.125.24Q</b>
400	30		72	4,4	TCG	<b>282.072.16M</b>		125	45	24	4,3-5,5	<b>288.125.24Q</b>
<b>PANHANS</b>												
250	30		60	3,2	TCG	<b>281.060.10M</b>	EURO 5, EURO 5 SFV	125	20	24	3,1-4	<b>288.125.24K</b>
300	30		60	4,4	TCG	<b>282.060.12M</b>	693/SH/SO	125	20	24	4,3-5,5	<b>288.125.24H2</b>
300	30		60	4,4	TCG	<b>282.060.12M</b>	EURO10 / SF, 693/SH70	180	30	36	4,3-5,5	<b>288.180.36M</b>
350	30	4	72	4,4	TCG	<b>282.072.14M</b>	EURO30SF, 693/SH90	180	30	36	4,3-5,5	<b>288.180.36M</b>
400	30		72	4,4	TCG	<b>282.072.14M</b>	693/SH110	180	30	36	4,3-5,5	<b>288.180.36M</b>
<b>SCHELLING</b>												
350	30	4	72	4,4	TCG	<b>282.072.14M</b>	FI, FM	200	20	36	4,3-5,5	<b>288.200.36H</b>
400	30		72	4,4	TCG	<b>282.072.16M</b>	FW/AW, AK	200	20	36	4,3-5,5	<b>288.200.36H</b>
<b>SCHWEBEDISSEN</b>												
450	80	2+4	72	4,8	TCG	<b>282.072.18W2</b>	S50, S50 CNC					
<b>SCHEER</b>												
250	30	2	60	3,2	TCG	<b>281.060.10M</b>	FM	140	16	24	3,1-4	<b>Y288.140.24E</b>
<b>SCM</b>												
350	30	4	72	4,4	TCG	<b>282.072.14M</b>	Z15, Z32, Z45	160	55	36	4,3-5,5	<b>288.160.360</b>
<b>SELCO</b>												
400	80	2+4	72	4,4	TCG	<b>282.072.16W2</b>	WN 200, WNT 200	200	65	36	4,3-5,5	<b>288.200.36J</b>
430	80	2+4	72	4,4	TCG	<b>282.072.17W2</b>	WN 200, WNT 200	300	65	72	4,3-5,5	<b>288.300.72J</b>
450	80	2+4	72	4,8	TCG	<b>282.072.18W2</b>	WN 200, WNT 200	200	65	36	4,3-5,5	<b>288.200.36J</b>
<b>STETON</b>												
300	30		60	4,4	TCG	<b>282.060.12M</b>	SPLENDIDA	120	30	24	4,3-5,5	<b>Y288.120.24M</b>
400	60	2	72	4,4	TCG	<b>282.072.16U</b>	S2000	180	30	36	4,3-5,5	<b>288.180.36M</b>
500	60	2	72	4,8	TCG	<b>282.072.20U</b>	CENTURY	180	30	36	4,7-6,0	<b>288.180.36M</b>



A new blade with trapezoidal tooth and special expansion slot cuts which will allow you to make a good crosscut on all kinds of wood and plywood.  
Very good performance guaranteed on laminates, chipboard and 2-sided melamine (using scoring blades).

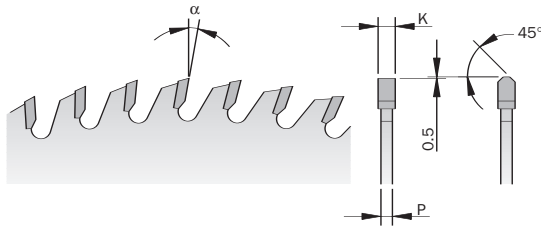

**TECHNICAL DETAILS OF CARBIDE TEETH:**

- Teeth height mm: 8~10
- Order no. ISO: K01F
- Hardness (HV10): 1.950
- Transverse rupture strength (N/mm<sup>2</sup>): 2.300

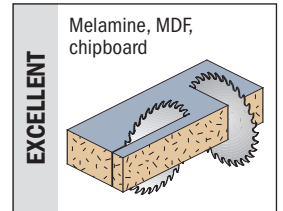

D Cutting diam. mm	F Ø bore mm	Pin hole 	Z No. of teeth	K Kerf thickness mm	P Plate thickness mm	α Hook angle	β Type of grind	ORDER NO.
250	30	COMBI3	60	3,2	2,2	10°	TCG	<b>281.060.10M</b>
250	30	COMBI3	80	3,2	2,2	10°	TCG	<b>281.080.10M</b>
300	30		60	4,4	3,2	16°	TCG	<b>282.060.12M</b>
300	30	COMBI3	72	3,2	2,2	10°	TCG	<b>281.072.12M</b>
300	30	COMBI3	96	3,2	2,2	10°	TCG	<b>281.096.12M</b>
300	75		60	4,4	3,2	16°	TCG	<b>282.060.12X</b>
300	80	4/9/100+2/14/110+2/7/110	60	4,4	3,2	16°	TCG	<b>282.060.12W</b>
350	30	4/9/100	72	4,4	3,2	16°	TCG	<b>282.072.14M</b>
350	30	2/10/60 + 2/7/42	108	3,5	2,5	10°	TCG	<b>281.108.14M</b>
350	50	3/12,5/80	72	4,4	3,2	16°	TCG	<b>282.072.14T</b>
350	75	4/15/105	72	4,4	3,2	16°	TCG	<b>282.072.14X</b>
350	80	4/9/100+2/14/110+2/7/110	72	4,4	3,2	16°	TCG	<b>282.072.14W</b>
380	60		72	4,8	3,5	16°	TCG	<b>282.072.15U</b>
400	30		72	4,4	3,2	16°	TCG	<b>282.072.16M</b>
400	60	2/11/85	72	4,4	3,2	16°	TCG	<b>282.072.16U</b>
400	75	4/15/105	72	4,4	3,2	16°	TCG	<b>282.072.16X</b>
400	80	2/9/130 + 4/19/120	72	4,4	3,2	16°	TCG	<b>282.072.16W2</b>
400	80	4/9/100+2/14/110+2/7/110	72	4,4	3,2	16°	TCG	<b>282.072.16W</b>
430	75	4/15/105	72	4,4	3,2	16°	TCG	<b>282.072.17X</b>
430	80	2/9/130 + 4/19/120	72	4,4	3,2	16°	TCG	<b>282.072.17W2</b>
450	60		72	4,8	3,5	16°	TCG	<b>282.072.18U</b>
450	80	2/9/130 + 4/19/120	72	4,8	3,5	16°	TCG	<b>282.072.18W2</b>
500	60	2/11/85	72	4,8	3,5	16°	TCG	<b>282.072.20U</b>
500	80	4/9/100+2/14/110+2/7/110	72	4,8	3,5	16°	TCG	<b>Y282.072.20W</b>
550	100		72	5,2	3,5	16°	TCG	<b>282.072.22A</b>

**Pin holes samples for panel sizing saw blades**

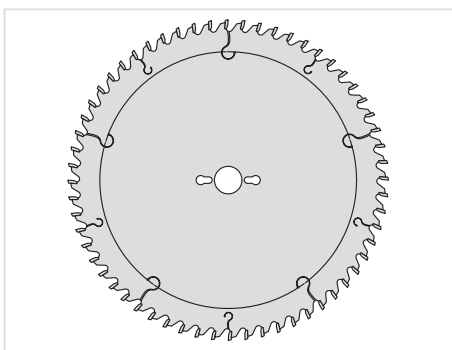

Saw blade with 2+2 pin holes  
(2/10/60 + 2/7/42)  
positioned at 180°

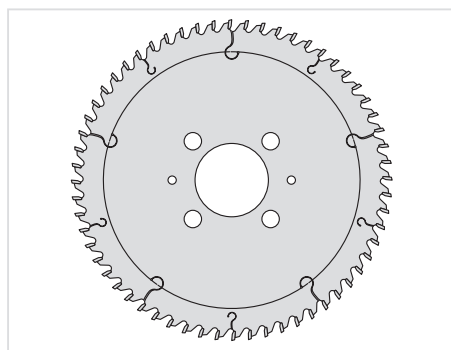

Saw blade with 2+4 pin holes  
(2/9/130 + 4/19/120)  
positioned at 180° and 90°

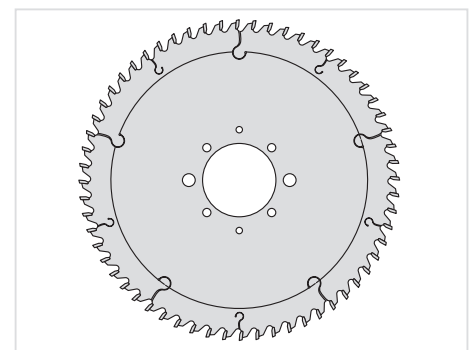

Saw blade with 4+2+2 pin holes  
(4/9/100 + 2/14/110 + 2/7/110)  
positioned at 90° and 180°





**284**



CMT blade designers and technicians present the Non-Ferrous Metal Saw Blade with the high quality performance you expect from CMT. Key features include high impact strength teeth made from special formulation carbide, a triple chip tooth configuration for longevity and a close tooth-to-body ratio which gives better support to the tooth. The positive hook angle provides controlled cutting for a smooth finish, without collapsing channel or storm window frames. Special gullet design allows for efficient chip evacuation.

**The CMT Non-Ferrous Metal Blade is ideal for industrial machines with the work piece properly clamped during cutting.**

**NOTE:** We highly recommend using a liquid lubricant. Wax stick for lubrication NOT RECOMMENDED.

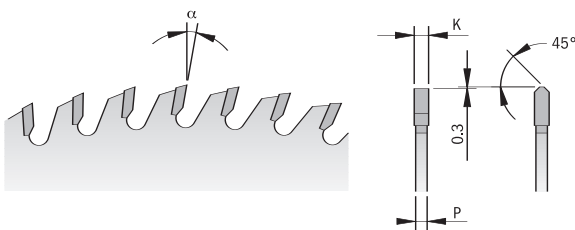

**TECHNICAL DETAILS OF CARBIDE TEETH:**

- Teeth height mm: 8
- Order no. ISO: K10
- Hardness (HV10): 1.765
- Transverse rupture strength (N/mm<sup>2</sup>): 2.150

**EXCELLENT** For all non-ferrous metals and PVC

**Saw blades for industrial machines. Positive hook angle**

D Blade diameter mm	F Bore diameter mm	Pin hole 	Z No. of teeth	K Kerf thickness mm	P Plate thickness mm	α Hook angle	β Type of grind	ORDER NO.
250	32	2/12/64	80	3,2	2,5	5° Pos.	TCG	<b>284.080.10P</b>
300	32	2/12/64	96	3,2	2,5	5° Pos.	TCG	<b>284.096.12P</b>
350	32	2/12/64	92	3,2	2,5	5° Pos.	TCG	<b>284.092.14P</b>
350	32	2/12/64	108	3,2	2,5	5° Pos.	TCG	<b>284.108.14P</b>
400	32	2/12/64	96	3,8	3,2	5° Pos.	TCG	<b>284.096.16P</b>
420	32	2/12/64	96	3,8	3,2	5° Pos.	TCG	<b>284.096.17P</b>
450	32	2/12/64	108	3,8	3,2	5° Pos.	TCG	<b>284.108.18P</b>
500	32	2/12/64	120	4	3,2	5° Pos.	TCG	<b>284.120.20P</b>

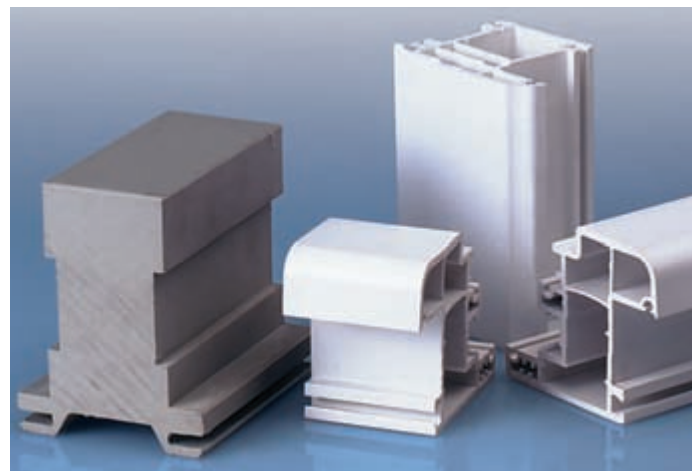
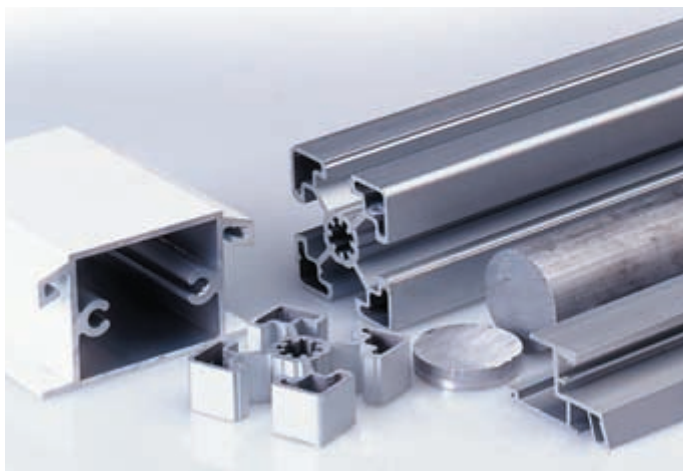



**296-297**



CMT blade designers and technicians present the Non-Ferrous Metal Saw Blade with the high quality performance you expect from CMT. Key features include high impact

strength teeth made from special formulation carbide, a triple chip tooth configuration for longevity and a close tooth-to-body ratio which gives better support to the tooth. The  $-6^\circ$  hook angle provides controlled cutting for a smooth finish, without collapsing channel or storm window frames. Special gullet design allows for efficient chip evacuation.

**The CMT Non-Ferrous Metal Blade is ideal for miter, radial and table saws and gives an optimum performance cutting aluminium, brass, non-ferrous metals, melamine and laminate.**

**NOTE:** We highly recommend using a liquid lubricant. Wax stick for lubrication NOT RECOMMENDED.

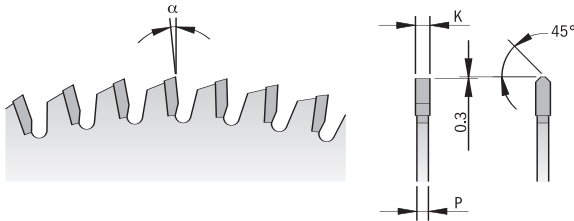

**TECHNICAL DETAILS OF CARBIDE TEETH:**

- Teeth height serie 296mm: 6
- Teeth height serie 297mm: 8
- Order no. ISO: K10
- Hardness (HV10): 1.765
- Transverse rupture strength (N/mm<sup>2</sup>): 2.150

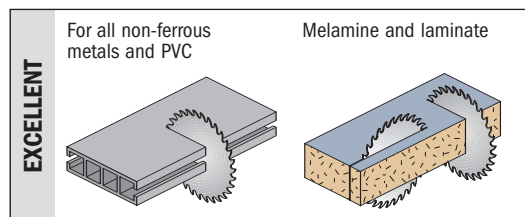

**Saw blades for portable machines. Negative hook angle**

D Blade diameter mm	F Bore diameter mm	Pin hole 	Z No. of teeth	K Kerf thickness mm	P Plate thickness mm	$\alpha$ Hook angle	$\beta$ Type of grind	ORDER NO.
160*	20	2/6/32	40	2,8	2,2	$-6^\circ$ Neg.	TCG	<b>296.160.40H</b>
160*	20	2/6/32	56	2,8	2,2	$-6^\circ$ Neg.	TCG	<b>296.160.56H</b>
180*	20	2/6/32	40	2,8	2,2	$-6^\circ$ Neg.	TCG	<b>296.180.40H</b>
190*	30	2/7/42	40	2,8	2,2	$-6^\circ$ Neg.	TCG	<b>296.190.40M</b>
190*	30	2/7/42	64	2,8	2,2	$-6^\circ$ Neg.	TCG	<b>296.190.64M</b>
190*	20 (Festool® FF)	Key 5/7/2,5	64	2,8	2,2	$-6^\circ$ Neg.	TCG	<b>296.190.64FF</b>
200*	30	COMBI3	48	2,8	2,2	$-6^\circ$ Neg.	TCG	<b>296.200.48M</b>
210*	30	2/7/42	48	2,8	2,2	$-6^\circ$ Neg.	TCG	<b>296.210.48M</b>
210*	30	2/7/42	64	2,8	2,2	$-6^\circ$ Neg.	TCG	<b>296.210.64M</b>
225*	30	2/7/42	64	2,8	2,2	$-6^\circ$ Neg.	TCG	<b>296.225.64M</b>
230*	30	2/7/42	48	2,8	2,2	$-6^\circ$ Neg.	TCG	<b>296.230.48M</b>
235*	30	2/7/42	48	2,8	2,2	$-6^\circ$ Neg.	TCG	<b>296.235.48M</b>

Remarks: supplied in plastic carry case

**Saw blades to fit on trim- and mitre saws, table saws and combined joinery machines. Negative hook angle**

D Blade diameter mm	F Bore diameter mm	Pin hole 	Z No. of teeth	K Kerf thickness mm	P Plate thickness mm	$\alpha$ Hook angle	$\beta$ Type of grind	ORDER NO.
216*	30		64	2,8	2,5	$-6^\circ$ Neg.	TCG	<b>297.064.09M</b>
250	30	COMBI3	80	3,2	2,5	$-6^\circ$ Neg.	TCG	<b>297.080.10M</b>
250	32	2/12/64	80	3,2	2,5	$-6^\circ$ Neg.	TCG	<b>297.080.10P</b>
260	30	2/10/60 + 2/7/42	80	3,2	2,5	$-6^\circ$ Neg.	TCG	<b>297.080.11M</b>
280	30	2/10/60 + 2/7/42	64	3,2	2,5	$-6^\circ$ Neg.	TCG	<b>297.064.11M</b>
300	30	COMBI3	96	3,2	2,5	$-6^\circ$ Neg.	TCG	<b>297.096.12M</b>
300	32	2/12/64	96	3,2	2,5	$-6^\circ$ Neg.	TCG	<b>297.096.12P</b>
305	30	2/10/60 + 2/7/42	96	3,2	2,5	$-6^\circ$ Neg.	TCG	<b>297.096.13M</b>
315	30	2/10/60 + 2/7/42	96	3,2	2,5	$-6^\circ$ Neg.	TCG	<b>297.096.23M</b>
350	30	COMBI3	108	3,2	2,5	$-6^\circ$ Neg.	TCG	<b>297.108.14M</b>
350	32	4/12/64	108	3,2	2,5	$-6^\circ$ Neg.	TCG	<b>297.108.14P</b>
400	32	4/12/64	108	3,8	3,2	$-6^\circ$ Neg.	TCG	<b>297.108.16P</b>
450	32	2/12/64	108	3,8	3,2	$-6^\circ$ Neg.	TCG	<b>297.108.18P</b>
500	32	2/12/64	120	4,0	3,2	$-6^\circ$ Neg.	TCG	<b>297.120.20P</b>

\* Non-low noise



226



Perfect "dry" cut on all universal metal chop saws, especially Jepson machines. Excellent cut quality!

The special teeth ground with the latest finest micrograin carbide provide a longer life of the blade. The ideal saw blades for all types of materials:

- **metals:** soft and stainless steel, cast and profiled iron, pipes, sheet in metal, brass and aluminium;
- **compound materials:** profiles and sandwich panels for aluminium doors and windows, sandwich panels with PVC surface;
- **PVC materials:** plexiglas, corean, hard and soft PVC;
- **wood:** any kind of soft and hard wood, chip-board panels, melamine, wood board with nails and stone.

**Remark:** Please pay attention to the under-mentioned maximum RPM.

Blade diameter	RPM Max
136	10900
160-165	9000
184-190	8000
210-235	6400
254	5900
305	4900
355	4200

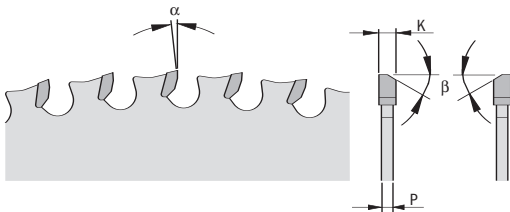

**EXCELLENT**

For iron, steel, PVC, compound materials, melamine and wood

**TECHNICAL DETAILS OF CARBIDE TEETH:**

- Teeth height mm: 5
- Order no. ISO: K30
- Hardness (HV10): 1.520
- Transverse rupture strength (N/mm<sup>2</sup>): 2.300

D Blade diameter		F Bore diameter		Z No. of teeth	K Kerf thickness	P Plate thickness	α Hook angle	β Type of grind	ORDER NO.
mm	inches	mm	inches		mm	mm			
136,5	5-3/8	10		30	1,5	1,2	0°	TCG	<b>226.030.05</b>
160		20		30	2,0	1,6	0°	TCG	<b>226.030.06H</b>
165	6-1/2	15,87	5/8	36	1,5	1,2	0°	TCG	<b>226.036.06</b>
165	6-1/2	20		36	1,5	1,2	0°	TCG	<b>226.036.06H</b>
184	7-1/4	15,87	5/8<>	48	2,0	1,6	0°	TCG	<b>226.048.07</b>
190		30		40	2,0	1,6	0°	TCG	<b>226.040.07M</b>
210	8-1/4	15,87	5/8<>	48	2,2	1,8	0°	TCG	<b>226.048.08</b>
210		30		48	2,2	1,8	0°	TCG	<b>226.048.08M</b>
235		30		48	2,2	1,8	0°	TCG	<b>226.048.09M</b>
254	10	15,87	5/8	60	2,2	1,8	0°	8° FWF	<b>226.060.10</b>
254	10	30		60	2,2	1,8	0°	8° FWF	<b>226.060.10M</b>
305	12	25,4	1	60	2,2	1,8	0°	8° FWF	<b>226.060.12</b>
305	12	25,4	1	80	2,2	1,8	0°	8° FWF	<b>226.080.12</b>
305	12	30		80	2,2	1,8	0°	8° FWF	<b>226.080.12M</b>
355	14	25,4	1	80	2,2	1,8	0°	8° FWF	<b>226.080.14</b>
355	14	25,4	1	90	2,2	1,8	0°	8° FWF	<b>226.090.14</b>
355	14	30		90	2,2	1,8	0°	8° FWF	<b>226.090.14M</b>

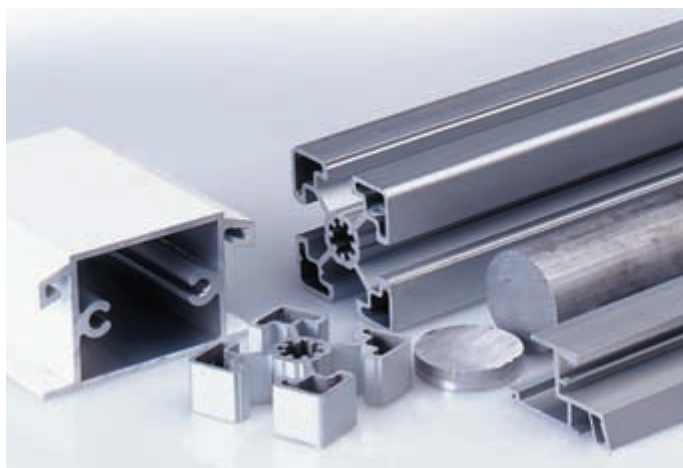



223



CMT has produced an innovative modified triple chip grind (MTCG) combined with a specialized micrograin carbide formulation for swirl free cuts in solid surface materials. This blade is ideal for solid surface materials that include: **DuPont Corian®**, **Wilsonart Gibraltar®**, **SSV Fountainhead®** and **Varicor®**. This blade is also ideal for cutting thick plastic for a melt free smooth finish.

**Safety Precautions:** Not recommended for use on miter saws.

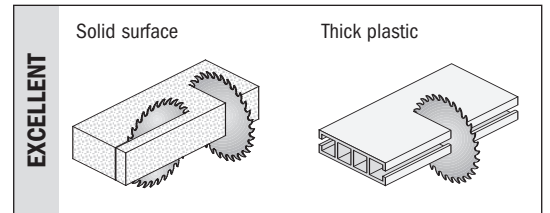
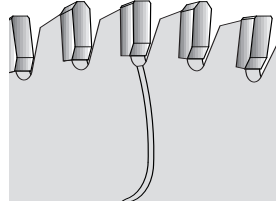
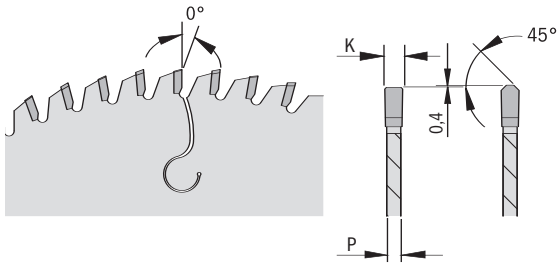

D Blade diameter mm	F Bore diameter mm	Z No. of teeth	K Kerf thickness mm	P Plate thickness mm	$\alpha$ Hook angle	$\beta$ Type of grind	ORDER NO.
250	30	72	3,2	2,5	0°	MTCG	223.072.10M
300	30	84	3,2	2,5	0°	MTCG	223.084.12M



222



This innovative industrial saw blade employs a special modified alternate top bevel grind (MATB) and a unique micro grain carbide formulation that allows it to cut plastics and plexiglass without melting! The blade gives excellent results in thin plastic, plexiglass, vinyl, plywood and laminated flooring and good results in thick plastic and laminates.

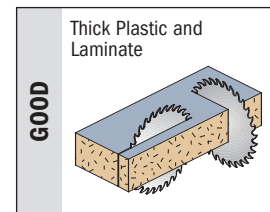
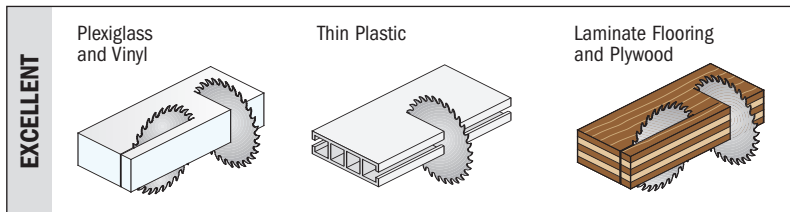
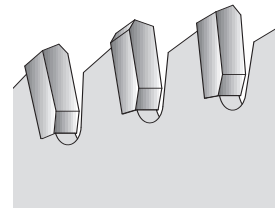
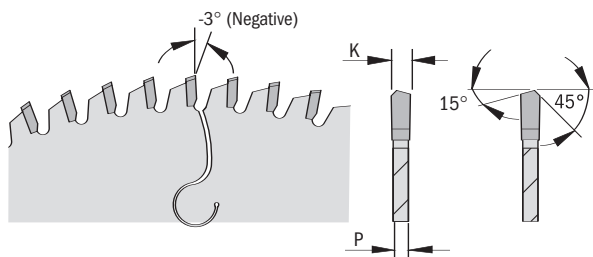

D Blade diameter mm	F Bore diameter mm	Z No. of teeth	K Kerf thickness mm	P Plate thickness mm	$\alpha$ Hook angle	$\beta$ Type of grind	ORDER NO.
250	30	80	2,8	2,2	-3°	MATB	222.080.10M
300	30	96	2,8	2,2	-3°	MATB	222.096.12M



CMT's Industrial Thin Kerf blades feature quality, durability and value that are setting new standards in saw blade technology. In fact, these blades offer a combination of price and quality that simply can't be matched anywhere.

Manufactured using breakthrough design features, the latest computer-controlled equipment and the world's finest steel and carbide, ITK blades offer all the advantages of a thin kerf blade, plus the quality that has made CMT a respected name throughout the world. Try ITK and see for yourself. From design to materials to production to packaging, the new standard of cutting performance is as simple as ITK.



## ITK Blades Feature:

- Anti-kickback design
- Ultra Thin Kerf
- Laser Cut Arbor and Plate
- High Quality Steel
- Tri-Metal Brazing
- Finest Micrograin Carbide
- Low Noise

## Ultra Thin Kerf rip and crosscut blades



271



Ultra ITK Rip & Crosscut Blades allow you to produce excellent finish cuts anywhere you can carry your portable saw: in the shop, on the job site, or wherever quality cuts are critical.

With a combination of flat and alternate top bevel teeth, new thin kerf design, Micrograin Carbide Teeth, Anti-Kickback Design, Tri-Metal Brazing, these blades deliver high performance with a minimum of stock removal, meaning there's less stress on the blade and your saw. **The best solution for your cordless circular saw machines!**

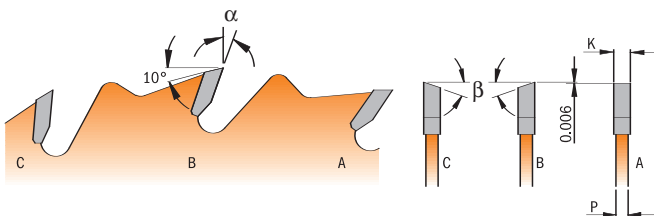
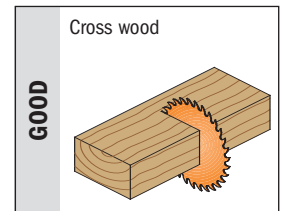
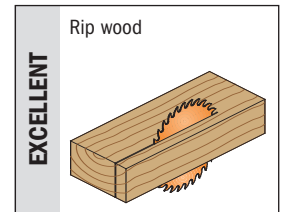

### TECHNICAL DETAILS OF CARBIDE TEETH:

- Teeth height mm: 5~6
- Order no. ISO: K20
- Hardness (HV10): 1.550
- Transverse rupture strength (N/mm<sup>2</sup>): 2.300

D Blade diameter mm	F Bore diameter mm	Z No. of teeth	K Kerf thickness mm	P Plate thickness mm	$\alpha$ Hook angle	$\beta$ Type of grind	ORDER NO.
130	16	12	1,3	0,8	25°	1 FTG+2/20° ATB	271.130.12E
136	10	18	1,5	1,0	20°	1 FTG+2/20° ATB	271.136.18D
150	20	18	1,3	0,8	20°	1 FTG+2/20° ATB	271.150.18H
160	16	18	1,3	0,8	20°	1 FTG+2/20° ATB	271.160.18E
160	20	18	1,3	0,8	20°	1 FTG+2/20° ATB	271.160.18H
165	16	18	1,3	0,8	20°	1 FTG+2/20° ATB	271.165.18
new 165	20	24	1,3	0,8	20°	1 FTG+2/20° ATB	271.165.24H
184	16	24	1,3	0,8	20°	1 FTG+2/20° ATB	271.184.24E
184	20	24	1,3	0,8	20°	1 FTG+2/20° ATB	271.184.24H
184	30	24	1,3	0,8	20°	1 FTG+2/20° ATB	271.184.24M
190	30	24	1,5	1,0	20°	1 FTG+2/20° ATB	271.190.24M
200	30	36	1,7	1,2	20°	1 FTG+2/15° ATB	271.200.36M
216	30	36	1,7	1,2	20°	1 FTG+2/15° ATB	271.216.36M
235	25	36	1,7	1,2	20°	1 FTG+2/15° ATB	271.235.36L
235	30	36	1,7	1,2	20°	1 FTG+2/15° ATB	271.235.36M
250	30	24	1,7	1,2	20°	1 FTG+2/15° ATB	271.250.24M
250	30	42	1,7	1,2	20°	1 FTG+2/15° ATB	271.250.42M
300	30	45	2,4	1,8	20°	1 FTG+2/15° ATB	271.300.45M



272



CMT's Ultra ITK Fine Compound Miter Blade are the ideal choice for extra-clean cuts and good all-around performance on table saws and miter saws. Thanks to our new thin kerf design, they remove a smaller cross-section of stock on each cut, reducing drag on your saw and material waste. Offered in 250 and 300mm diameters with a pattern of one flat-top and two 15° ATB teeth, these blades deliver excellent crosscuts in wood or plywood, beautiful plywood rips, and even do a nice job on the occasional rip in hard or soft wood. And when you choose an Ultra ITK blade, you also receive CMT's Anti-Kickback Design, Tri-Metal Brazing and Laser Cut Arbors, plus laser-marked safety instructions and illustrated resharpening information.

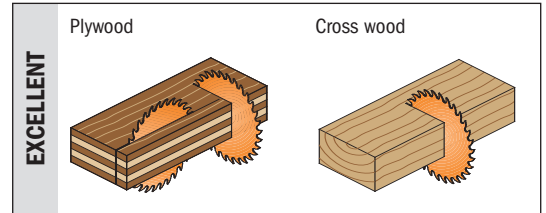

**TECHNICAL DETAILS OF CARBIDE TEETH:**

- Teeth height mm: 5~8
- Order no. ISO: K01
- Hardness (HV10): 1.840
- Transverse rupture strength (N/mm²): 2.050

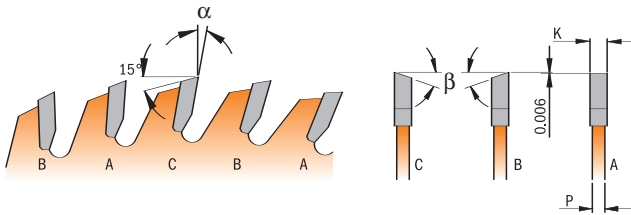

D Blade diameter mm	F Bore diameter mm	Z No. of teeth	K Kerf thickness mm	P Plate thickness mm	α Hook angle	β Type of grind	ORDER NO.
136	10	36	1,3	0,8	20°	1 FTG+2/15° ATB	<b>272.136.36D</b>
165	16	36	1,3	0,8	20°	1 FTG+2/20° ATB	<b>272.165.36</b>
165	20	36	1,3	0,8	20°	1 FTG+2/20° ATB	<b>272.165.36H</b>
184	30	42	1,3	0,8	20°	1 FTG+2/20° ATB	<b>272.184.42M</b>
250	30	60	1,7	1,2	20°	1 FTG+2/15° ATB	<b>272.250.60M</b>
300	30	72	2,4	1,8	20°	1 FTG+2/15° ATB	<b>272.300.72M</b>



**Ultra Thin Kerf fine finish blades**



273



Need the best possible cuts in 2-sided laminates? Need to crosscut expensive veneer plywood with the absolute minimum waste? Need to make your cuts with speed, efficiency and the least possible demand on your table saw or radial arm saw? Then you need CMT's remarkable new Ultra ITK Fine Finish Blades with alternate top bevel teeth with a razor-sharp 40° angle, a precision design that delivers incredibly clean cuts, even in two-sided melamine. Of course, tooth design is only one part of the cutting equation. You also need a balanced plate with laser cut arbors and slots to ensure true, vibration-free rotation, micrograin carbide teeth, shock-resistant tri-metal brazing, and CMT's Ultra ITK blades deliver all that and more!

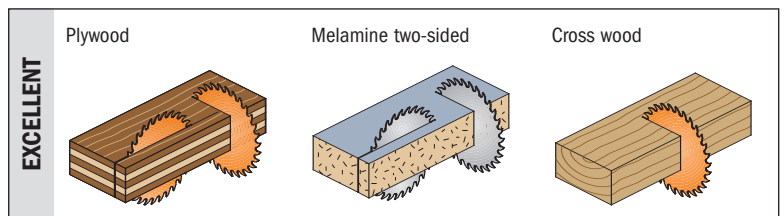

**TECHNICAL DETAILS OF CARBIDE TEETH:**

- Teeth height mm: 7~8
- Order no. ISO: K01F
- Hardness (HV10): 1.950
- Transverse rupture strength (N/mm²): 2.300

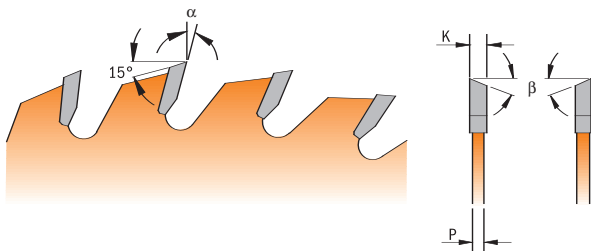

D Blade diameter mm	F Bore diameter mm	Z No. of teeth	K Kerf thickness mm	P Plate thickness mm	α Hook angle	β Type of grind	ORDER NO.
250	30	80	1,7	1,2	15°	40° ATB	<b>273.250.80M</b>
300	30	96	2,4	1,8	15°	40° ATB	<b>273.300.96M</b>



290



Alternate top bevel ground teeth, a low number of teeth and a 20° hook angle make the CMT rip blade ideal for glue line rips in hard and soft woods. Ideal for automatic and manual feeding with low feed rate force. Equipped with pin holes suitable for the most popular machines.

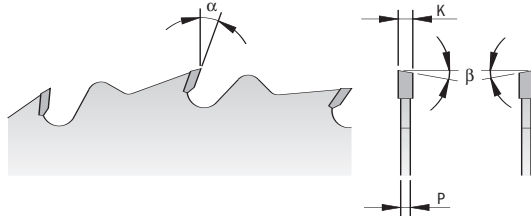

**TECHNICAL DETAILS OF CARBIDE TEETH:**

- Teeth height mm: 6~8
- Order no. ISO: K10
- Hardness (HV10): 1.765
- Transverse rupture strength (N/mm²): 2.150

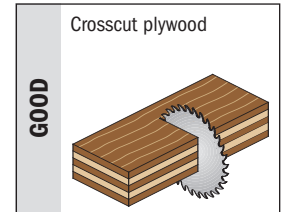
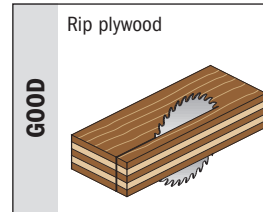
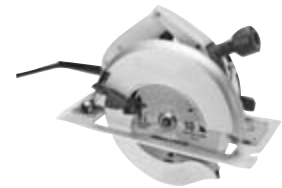
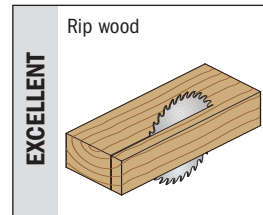

D Blade diameter mm	F Bore diameter mm	Pin hole 	Z No. of teeth	K Kerf thickness mm	P Plate thickness mm	α Hook angle	β Type of grind	ORDER NO.
150	20		12	2,4	1,4	20°	10° ATB	290.150.12H
160	16		12	2,6	1,6	20°	10° ATB	290.160.12E
160	20	2/6/32	12	2,6	1,6	20°	10° ATB	290.160.12H
180	30	2/7/42	12	2,6	1,6	20°	10° ATB	290.180.12M
190	16	2/6/32	12	2,6	1,6	20°	10° ATB	290.190.12E
190	20	2/6/32	12	2,6	1,6	20°	10° ATB	290.190.12H
190	30	2/7/42	12	2,6	1,6	20°	10° ATB	290.190.12M
200	30	2/7/42	24	2,8	1,8	20°	10° ATB	290.200.24M
210	25		24	2,8	1,8	20°	10° ATB	290.210.24L
210	30	2/7/42	24	2,8	1,8	20°	10° ATB	290.210.24M
216	30		24	2,8	1,8	-5° Neg.	15° ATB	290.216.24M
220	30	2/7/42	24	2,8	1,8	20°	10° ATB	290.220.24M
230	30	2/7/42	24	2,8	1,8	20°	10° ATB	290.230.24M
235	25		24	2,8	1,8	20°	10° ATB	290.235.24L
235	30	2/7/42	24	2,8	1,8	20°	10° ATB	290.235.24M
240	30	2/7/42	24	2,8	1,8	20°	10° ATB	290.240.24M
250	30	COMBI3	24	2,8	1,8	20°	10° ATB	290.250.24M
270	30	2/7/42	28	2,8	1,8	20°	10° ATB	290.270.28M

Garden trimmer saw blades



298



Saw blade especially designed to cut bushes and small trees with your hedge trimmers.

**Please always wear safety glasses and ear protection.**

**Please always use the safety guard provided with your machine.**

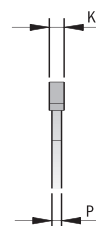
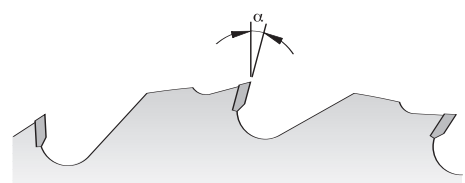

**TECHNICAL DETAILS OF CARBIDE TEETH:**

- Teeth height mm: 6
- Order no. ISO: special
- Hardness (HV10): 1.550
- Transverse rupture strength (N/mm²): 2.600



D Blade diameter mm	F Bore diameter mm	RPM max	Z No. of teeth	K Kerf thickness mm	P Plate thickness mm	α Hook angle	β Type of grind	ORDER NO.
250	20	12.000	20	2,2	1,8	25°	ATB	298.250.20H
250	25,4	12.000	20	2,2	1,8	25°	ATB	298.250.20



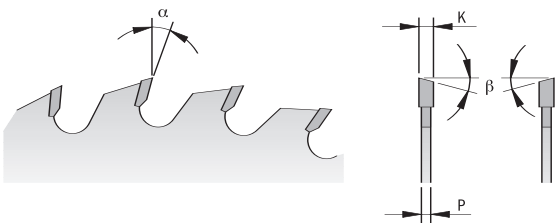

Get the speed and efficiency you need with its 15° or 20° hook angle and medium number of teeth. Whether ripping or cross cutting you can work a wide range of materials, like soft and hard woods, plywood and melamine, with accuracy and efficiency. Equipped with pin holes suitable for most popular machines. A must for professional woodworkers.

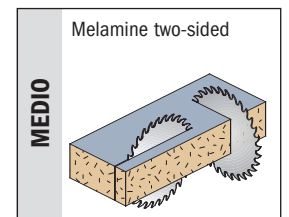
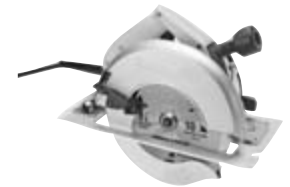
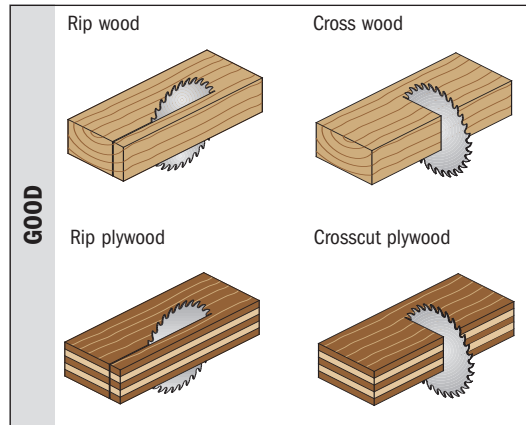

**TECHNICAL DETAILS OF CARBIDE TEETH:**

- Teeth height mm: 6~8
- Order no. ISO: K10
- Hardness (HV10): 1.765
- Transverse rupture strength (N/mm<sup>2</sup>): 2.150



D Blade diameter mm	F Bore diameter mm	Pin hole 	Z No. of teeth	K Kerf thickness mm	P Plate thickness mm	α Hook angle	β Type of grind	ORDER NO.
125	20		20	2,4	1,4	15°	15° ATB	<b>291.125.20H</b>
130	20		20	2,4	1,4	15°	15° ATB	<b>291.130.20H</b>
140	20		20	2,4	1,4	15°	15° ATB	<b>291.140.20H</b>
150	16		24	2,4	1,4	15°	15° ATB	<b>291.150.24E</b>
150	20		24	2,4	1,4	15°	15° ATB	<b>291.150.24H</b>
160	16		24	2,6	1,6	15°	15° ATB	<b>291.160.24E</b>
160	20	2/6/32	24	2,6	1,6	15°	15° ATB	<b>291.160.24H</b>
160	30	2/7/42	24	2,6	1,6	15°	15° ATB	<b>291.160.24M</b>
165	20	2/6/32	24	2,6	1,6	15°	15° ATB	<b>291.165.24H</b>
165	30	2/7/42	24	2,6	1,6	15°	15° ATB	<b>291.165.24M</b>
170	30	2/7/42	24	2,6	1,6	20°	10° ATB	<b>291.170.24M</b>
180	20	2/6/32	24	2,6	1,6	20°	10° ATB	<b>291.180.24H</b>
180	30	2/7/42	24	2,6	1,6	20°	10° ATB	<b>291.180.24M</b>
184	16		24	2,6	1,6	20°	10° ATB	<b>291.184.24E</b>
184	30		24	2,6	1,6	20°	10° ATB	<b>291.184.24M</b>
190	16	2/6/32	24	2,6	1,6	20°	10° ATB	<b>291.190.24E</b>
190	20	2/6/32	24	2,6	1,6	20°	10° ATB	<b>291.190.24H</b>
190	30	2/7/42	24	2,6	1,6	20°	10° ATB	<b>291.190.24M</b>
190	20 (Festool® FF)	Key 5/7/2,5	32	2,6	1,6	10°	10° ATB	<b>291.190.32FF</b>
200	30	2/7/42	36	2,8	1,8	15°	15° ATB	<b>291.200.36M</b>
210	25		36	2,8	1,8	15°	15° ATB	<b>291.210.36L</b>
210	30	2/7/42	36	2,8	1,8	15°	15° ATB	<b>291.210.36M</b>
216	30		48	2,8	1,8	-5° Neg.	15° ATB	<b>291.216.48M</b>
220	30	2/7/42	36	2,8	1,8	15°	15° ATB	<b>291.220.36M</b>
225	30	2/7/42	36	2,8	1,8	20°	15° ATB	<b>291.225.36M</b>
230	30	2/7/42	36	2,8	1,8	15°	15° ATB	<b>291.230.36M</b>
235	25		36	2,8	1,8	15°	15° ATB	<b>291.235.36L</b>
235	30	2/7/42	36	2,8	1,8	15°	15° ATB	<b>291.235.36M</b>
240	30	2/7/42	36	2,8	1,8	15°	15° ATB	<b>291.240.36M</b>
250	20	COMBI3	40	3,2	2,2	15°	10° ATB	<b>285.040.10H</b>
250	30	COMBI3	40	3,2	2,2	15°	10° ATB	<b>285.040.10M</b>
260	30	2/10/60 + 2/7/42	48	3,2	2,2	15°	10° ATB	<b>285.048.11M</b>
270	30	2/7/42	42	2,8	1,8	15°	15° ATB	<b>291.270.42M</b>





**292**



THE all-around cut off blade for hardwood, softwood, plywood, chipboard and MDF. The alternate top bevel teeth, 10 or 15° hook angle and high tooth count make this blade perfect for use on all your professional machines. With the ultimate fishhook expansion design your blade runs smoother and works more efficiently.

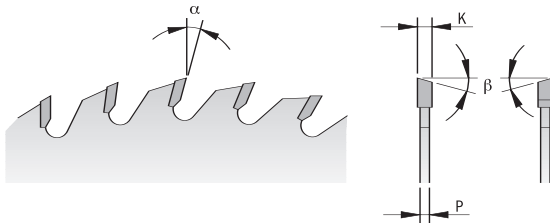

**TECHNICAL DETAILS OF CARBIDE TEETH:**

- Teeth height mm: 6~8
- Order no. ISO: K10
- Hardness (HV10): 1.765
- Transverse rupture strength (N/mm<sup>2</sup>): 2.150

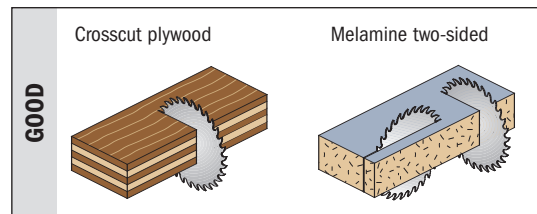
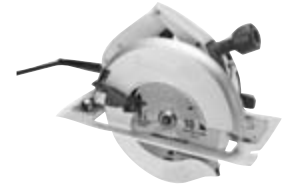
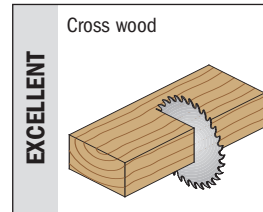

D Blade diameter mm	F Bore diameter mm	Pin hole 	Z No. of teeth	K Kerf thickness mm	P Plate thickness mm	α Hook angle	β Type of grind	ORDER NO.
150	20		40	2,4	1,4	15°	15° ATB	<b>292.150.40H</b>
160	16		40	2,6	1,6	10°	15° ATB	<b>292.160.40E</b>
160	20	2/6/32	40	2,6	1,6	10°	15° ATB	<b>292.160.40H</b>
160*	20	4/7/32 (45°)	40	2,4	1,6	10°	TCG	<b>281.160.40H</b>
160	30	2/7/42	40	2,6	1,6	10°	15° ATB	<b>292.160.40M</b>
160	20	2/7/42	56	2,6	1,6	15°	15° ATB	<b>292.160.56H</b>
165	20	2/6/32	40	2,6	1,6	10°	15° ATB	<b>292.165.40H</b>
165	30	2/7/42	40	2,6	1,6	15°	15° ATB	<b>292.165.40M</b>
170	30	2/7/42	40	2,6	1,6	15°	15° ATB	<b>292.170.40M</b>
180	20	2/6/32	40	2,6	1,6	15°	15° ATB	<b>292.180.40H</b>
180	30	2/7/42	40	2,6	1,6	15°	15° ATB	<b>292.180.40M</b>
184	16		40	2,6	1,6	15°	15° ATB	<b>292.184.40E</b>
184	30		40	2,6	1,6	15°	15° ATB	<b>292.184.40M</b>
190	16	2/6/32	40	2,6	1,6	15°	15° ATB	<b>292.190.40E</b>
190	20	2/6/32	40	2,6	1,6	15°	15° ATB	<b>292.190.40H</b>
190	30	2/7/42	40	2,6	1,6	15°	15° ATB	<b>292.190.40M</b>
190	30	2/7/42	64	2,6	1,6	15°	15° ATB	<b>292.190.64M</b>
190	20 (Festool® FF)	Key 5/7/2,5	48	2,4	1,6	10°	15° ATB	<b>292.190.48FF</b>
200	30	2/7/42	48	2,8	1,8	15°	15° ATB	<b>292.200.48M</b>
210	25		48	2,8	1,8	15°	15° ATB	<b>292.210.48L</b>
210	30	2/7/42	48	2,8	1,8	15°	15° ATB	<b>292.210.48M</b>
210	30	2/7/42	64	2,8	1,8	15°	15° ATB	<b>292.210.64M</b>
216	30		64	2,8	1,8	-5° Neg.	15° ATB	<b>292.216.64M</b>
220	30	2/7/42	48	2,8	1,8	15°	15° ATB	<b>292.220.48M</b>
225	30	2/7/42	48	2,8	1,8	10°	15° ATB	<b>292.225.48M</b>
230	30	2/7/42	48	2,8	1,8	15°	15° ATB	<b>292.230.48M</b>
230	30	2/7/42+2/10/60	64	2,8	1,87	15°	15° ATB	<b>292.230.64M</b>
235	25		48	2,8	1,8	15°	15° ATB	<b>292.235.48L</b>
235	30	2/7/42	48	2,8	1,8	15°	15° ATB	<b>292.235.48M</b>
240	30	2/7/42	48	2,8	1,8	15°	15° ATB	<b>292.240.48M</b>
250	30	COMBI3	60	3,2	2,2	10°	15° ATB	<b>285.060.10M</b>
260	30	2/10/60 + 2/7/42	60	3,2	2,2	10°	15° ATB	<b>285.060.11M</b>

\* Suitable for Virutex machine



**236**



Saw blades for ultra-hard materials now available in several diameter for miter saws and portable saws. Hardiplank® and Hardipanel® are becoming a household name with the building contractor. Cutting these materials efficiently while keeping the dust to a minimum has been a challenge for tooling manufacturers. The CMT solution for the cutting of Hardiplank® and Hardipanel® has been a four tooth polycrystalline diamond blade for the use on hand held circular saws. The ideal saw blade for all type of ultra-hard materials like: Hardiplank® and Hardipanel®, Chipboard, MDF, Corian, Duroplast, Formica, Thermoplast, Trespa and Plasterboard.

**EXCELLENT**

Hardiplank® e Hardipanel®, Chipboard, MDF, Corian, Duroplast, Formica, Thermoplast, Trespa and Plasterboard.

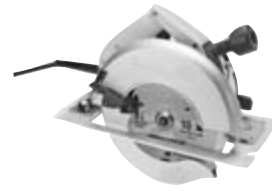
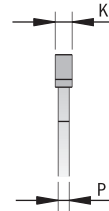

\* Non-low noise

D Blade diameter		F Bore diameter		Z No. of teeth	K Kerf thickness	P Plate thickness	α Hook angle	β Type of grind	ORDER NO.
mm	inches	mm	inches		mm	mm			
160		20		4	2,2	1,6	12°	FLAT	<b>236.160.04H</b>
180		20		4	2,2	1,6	12°	FLAT	<b>236.180.04H</b>
184,5	7-1/4	15,87	5/8<>	4	2,2	1,6	12°	FLAT	<b>236.004.07</b>
190		30		4	2,2	1,6	12°	FLAT	<b>236.190.04M</b>
230		30		4	2,2	1,6	12°	FLAT	<b>236.230.04M</b>
254*	10	15,87	5/8	6	2,2	1,6	12°	FLAT	<b>236.006.10</b>
305*	12	25,4	1	8	2,2	1,6	12°	FLAT	<b>236.008.12</b>

**Ultra Thin Kerf saw blades**

for cordless saws



**271**  
**272**  
**226**



Ultra ITK Rip, Crosscut and Metal Blades allow you to produce excellent finish cuts anywhere you can carry your cordless saws: in the shop, on the job site, or wherever quality cuts are critical.

With a combination of flat and alternate top bevel teeth, new thin kerf design, Micrograin Carbide Teeth, Anti-Kickback Design, Tri-Metal Brazing, these blades deliver high performance with a minimum of stock removal, meaning there's less stress on the blade and your saw.

**The best solution for your cordless circular saw machines!**

**"ULTRA ITK" INDUSTRIAL THIN KERF**

**271-272**

**226**

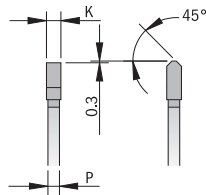
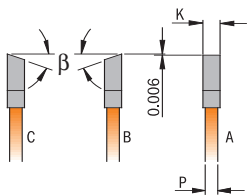

**EXCELLENT**

Rip wood (series 271)

**EXCELLENT**

Cross wood (series 272)

**EXCELLENT**

Metals and PVC (series 226)

D	F		Z	K	P	α	β	ORDER NO.
Blade diameter	Bore diameter		No. of teeth	Kerf thickness	Plate thickness	Hook angle	Type of grind	
mm	mm	inches		mm	mm			
<b>Ripping and crosscutting cordless saw blades</b>								
136	5-3/8	10	18	1,5	1,0	20°	1FTG+2/20° ATB	<b>271.136.18D</b>
165	6-1/2	16 5/8	18	1,3	0,8	20°	1FTG+2/20° ATB	<b>271.165.18</b>
<b>new</b> 165	6-1/2	20	24	1,3	0,8	20°	1FTG+2/20° ATB	<b>271.165.24H</b>
184	7-1/4	16 5/8	24	1,3	0,8	20°	1FTG+2/20° ATB	<b>271.184.24E</b>
<b>Fine cut cordless saw blades</b>								
136	5-3/8	10	36	1,3	0,8	20°	1FTG+2/15° ATB	<b>272.136.36D</b>
165	6-1/2	16 5/8	36	1,3	0,8	20°	1FTG+2/20° ATB	<b>272.165.36</b>
<b>new</b> 165	6-1/2	20	36	1,3	0,8	20°	1FTG+2/20° ATB	<b>272.165.36H</b>
<b>Metal, PVC and compound materials cordless saw blades</b>								
136,5	5-3/8	10	30	1,5	1,2	0°	TCG	<b>226.030.05</b>
165	6-1/2	16 5/8	36	1,5	1,2	0°	TCG	<b>226.036.06</b>



240



Special saw blades with reinforced plate for grooves cuts on soft and hard wood, MDF and chipboard.



The new design allows multiple grooves using different kerf thickness

**TECHNICAL DETAILS OF CARBIDE TEETH:**

- Teeth height mm: 10
- Order no. ISO: K01
- Hardness (HV10): 1.840
- Transverse rupture strength (N/mm<sup>2</sup>): 2.050

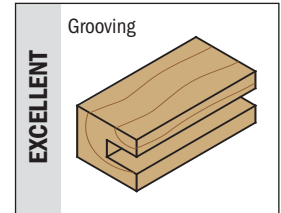
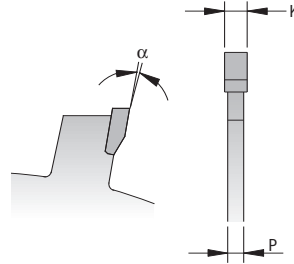

D Blade diameter mm	F Bore diameter mm	Z No. of teeth	K Kerf thickness mm	P Plate thickness mm	α Hook angle	β Type of grind	ORDER NO.
150	30	12	2	1,4	15°	FLAT	240.020.06M
150	35	12	2	1,4	15°	FLAT	240.020.06R
150	30	12	3	2,0	15°	FLAT	240.030.06M
150	35	12	3	2,0	15°	FLAT	240.030.06R
150	30	12	4	3,0	15°	FLAT	240.040.06M
150	35	12	4	3,0	15°	FLAT	240.040.06R
150	30	12	5	3,0	15°	FLAT	240.050.06M
150	35	12	5	3,0	15°	FLAT	240.050.06R
150	30	12	6	3,0	15°	FLAT	240.060.06M
150	35	12	6	3,0	15°	FLAT	240.060.06R
180	30	18	3	2,0	15°	FLAT	240.030.07M
180	35	18	3	2,0	15°	FLAT	240.030.07R
180	30	18	4	3,0	15°	FLAT	240.040.07M
180	35	18	4	3,0	15°	FLAT	240.040.07R
180	30	18	5	3,0	15°	FLAT	240.050.07M
180	35	18	5	3,0	15°	FLAT	240.050.07R
180	30	18	6	3,0	15°	FLAT	240.060.07M
180	35	18	6	3,0	15°	FLAT	240.060.07R



**240.004.04**



The new CMT Mini-Spot saw blade are ideal to do any type of small repairing on solid wood. Resin, knots and other wood flaws are not a problem any more: with this product and using original patches the cut points will be covered up perfectly.

After repairing the patches will be practically invisible because the wood and patches grains will be in the same direction.

To use with Lamello or other machines.

D Blade diameter mm	F Bore diameter mm	Z No. of teeth	K Kerf thickness mm	P Plate thickness mm	α Hook angle	ORDER NO.
100	22	4	8	6	18°	<b>240.004.04</b>

**Biscuits joiner blades**

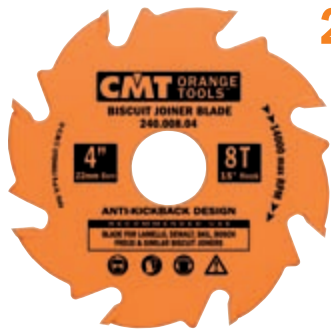

**240/241**

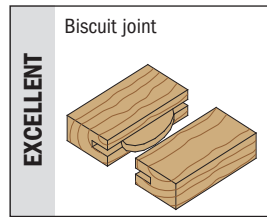

The 100mm CMT Biscuit Joiner blades with trademark orange PTFE Industrial coating make biscuit joining quick and easy. High-grade German steel and 8 micrograin carbide tipped teeth guarantee years of use. Fits Lamello, DeWalt, Porter-Cable, Skil, Bosch, Freud and other popular biscuit joiners models.

D Blade diameter mm	F Bore diameter mm	Z No. of teeth	K Kerf thickness mm	P Plate thickness mm	α Hook angle	β Type of grind	ORDER NO.
100	22	6	3,96	3	15°	15°ATB	<b>240.006.04</b>
100	22	8	3,96	3	15°	15°ATB	<b>240.008.04</b>
100*	22	8	3,96	3	15°	15°ATB	<b>241.008.04</b>

\* For Virutex, Porter-Cable machines





**"ULTRA ITK" INDUSTRIAL THIN KERF**

**250**  
**251**



Take the finest industrial quality blade right to the job site with CMT's new ITK Framing / Decking blades. Offered in 184mm (7-1/4") diameters with 24 micro-grain carbide teeth and Finish blades with teeth.

They feature a combination of one flat-top tooth followed by a pair of alternating top bevel teeth - the ideal combination for accurate, efficient cuts with hand-held saws. Those teeth are ground from a special carbide that stands up well to the occasional nail or other imperfection you encounter in harsh construction environments. CMT's thin kerf blades put far less load on your saw than conventional blades, delivering faster cuts and longer life for the blade and saw. Every ITK blade includes all of our latest design features, including Anti-Kickback Design, Tri-Metal Brazing, and Laser Cut Arbors and Plates.

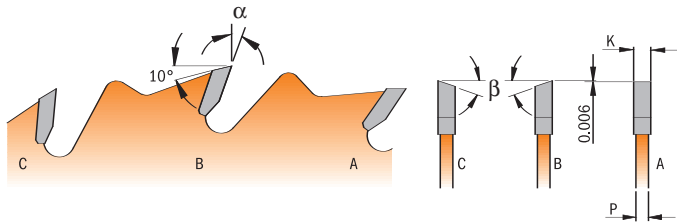

<b>EXCELLENT</b>	Rip wood (series 250)	Cross wood (series 251)



\*10 pcs.

D Blade diameter		F Bore diameter		Z No. of teeth	K Kerf thickness	P Plate thickness	α Hook angle	β Type of grind	ORDER NO.
mm	inches	mm	inches		mm	mm			
184	7-1/4	15,87	5/8 <>	24	1,9	1,2	20°	1FTG+2/20° ATB	<b>250.024.07</b>
184	7-1/4	15,87	5/8 <>	24	1,9	1,2	20°	1FTG+2/20° ATB	<b>250.024.07-X10*</b>
184	7-1/4	15,87	5/8 <>	40	1,9	1,2	20°	1FTG+4/20° ATB	<b>251.040.07</b>
184	7-1/4	15,87	5/8 <>	40	1,9	1,2	20°	1FTG+4/20° ATB	<b>251.040.07-X10*</b>

**Precision dado**

**new**



**230**



CMT thoroughly researched the shortcomings of "standard" dado sets and learned what cabinet makers required most from an "ideal" dado. The result was the superior CMT precision dado, designed with the following features:

- Anti-kickback design to reduce the possibility of overfeeding that can occur when cutting mass material.
- Splinter resistant cuts in veneer plywood, melamine and hard and soft woods;
- Shim sets included for cuts between 6,35mm (1/4") and 23mm (29/32").

**Set includes:**

			Shims set contains No. Shim Width 3 0.1 mm 2 0.2 mm 1 0.3 mm 1 0.5 mm
<b>2 BLADES</b>	<b>SHIM SET</b>	<b>5 CARBIDE TIPPED TWO TOOTH CHIPPERS</b>	



Splinter resistant cuts in all woods, plywoods and wood composites.

Precise cuts for accurate fitting dado-groove joints

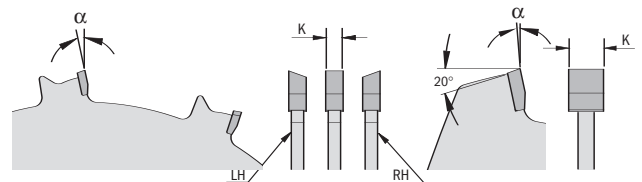
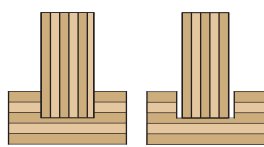

D Blade diameter		F Bore diameter		Z No. of teeth	K Kerf thickness	α Hook angle	β Type of grind	ORDER NO.
mm	inches	mm	inches		mm			
150	6	15,87	5/8	20	3,2	-5°	FTG+ATB	<b>230.520.06</b>
200	8	15,87	5/8	12	3,2	-12°	FTG+ATB	<b>230.012.08</b>
200	8	15,87	5/8	24	3,2	-5°	FTG+ATB	<b>230.524.08</b>
200	8	30		24	3,2	-5°	FTG+ATB	<b>230.524.08M</b>



**299.11**



Before starting a saw project, balance your CMT blade in your table saw with the CMT Balance Blade & Sanding Disk in your table saw and line it up with a square for accuracy. Remove the balance blade and mount your saw blade for true and precise cuts.

Or use the balance blade & sanding disk a sander by attaching a self-stick sandpaper disk to the balance blade and installing it in your table saw.

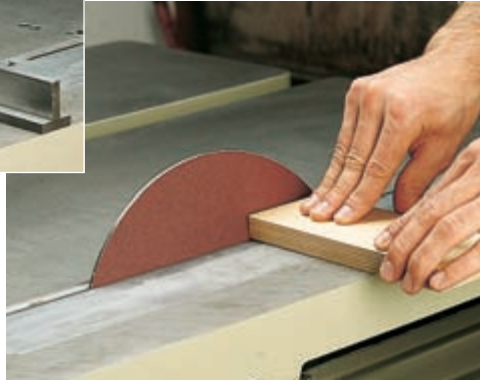

D Blade diameter		F Bore diameter		ORDER NO.
mm	inches	mm	inches	
200	8	15,87	5/8	<b>299.111.00</b>
200	8	30		<b>299.111.00M</b>
250	10	15,87	5/8	<b>299.112.00</b>
250	10	30		<b>299.112.00M</b>

**Saw blades stabilizer**



**299.10**



The CMT blade stabilizer virtually eliminates rim vibration to make cleaner, straighter cuts and extend the life of your CMT saw blade. It also helps to eliminate distracting noise caused by vibration during cutting.

NOTE: for use on stationary saws only.  
Each order includes 2 stabilizer.

Description	D Blade diameter		F Bore diameter		ORDER NO.
	mm	inches	mm	inches	
Stabilizer (2 pcs.) for Ø200mm	75	3	15,87	5/8	<b>299.101.00</b>
Stabilizer (2 pcs.) for Ø200mm	75	3	30		<b>299.101.00M</b>
Stabilizer (2 pcs.) for Ø250mm	125	5	15,87	5/8	<b>299.102.00</b>
Stabilizer (2 pcs.) for Ø250mm	125	5	30		<b>299.102.00M</b>

**Reduction rings for saw blades**

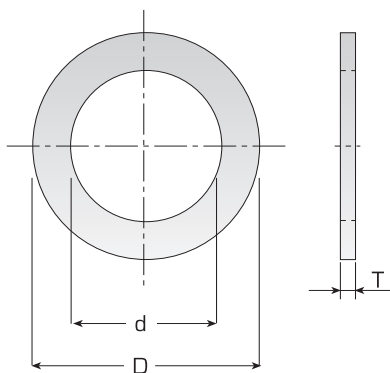

**299**

D Blade diameter	d Small diameter	T Thickness	ORDER NO.
mm	mm	mm	
20	12,7	1,2	<b>299.221.00</b>
20	16	1,2	<b>299.222.00</b>
25,4	19,05	1,4	<b>299.213.00</b>
25,4	20	1,4	<b>299.214.00</b>
25,4	22	1,4	<b>299.215.00</b>
30	15,87	1,4	<b>299.211.00</b>
30	16	1,4	<b>299.223.00</b>
30	16	2,0	<b>299.226.00</b>
30	18	1,4	<b>299.232.00</b>
30	20	1,4	<b>299.224.00</b>
30	22	1,4	<b>299.231.00</b>
30	20	2,0	<b>299.227.00</b>
30	25	1,4	<b>299.225.00</b>
30	25	2,0	<b>299.228.00</b>
30	25,4	2,0	<b>299.212.00</b>
32	30	2,0	<b>299.229.00</b>
35	30	2,0	<b>299.230.00</b>
35	32	2,0	<b>299.233.00</b>

MACHINE	Blade diam. mm	Bore diam. mm	RIPPING ORDER NO.	UNIVERSAL ORDER NO.	FINE CUT OFF ORDER NO.
<b>AEG</b>					
HK125A, HK125B	125	20		291.125.20H	
TKS42	130	20		291.130.20H	
HK40	140	20		291.140.20H	
HK45A, HK46S, HK52, HK737, HK46N, HKS52, AHK52, HKS46	150	20	290.150.12H	291.150.24H	292.150.40H
K55, K55E, K160, HK55	160	20	290.160.12H	291.160.24H	292.160.40H
HK190, HK65, HK66, HKS65, HKS66, HKSE66, K66,	190	30	290.190.12M	291.190.24M	292.190.40M
HK201	200	30	290.200.24M	291.200.36M	292.200.48M
HK75, HKS75	210	30	290.210.24M	291.210.36M	292.210.48M
HKS85, HKS35	230	30	290.230.24M	291.230.36M	292.230.48M
HK240	240	30	290.240.24M	291.240.36M	292.240.48M
<b>ATLAS COPCO</b>					
TKS42	130	20		291.130.20H	
K55S, K55SE	160	20	290.160.12H	291.160.24H	292.160.40H
K66S, K66SE	190	30	290.190.12M	291.190.24M	292.190.40M
HKS75	210	30	290.210.24M	291.210.36M	292.210.48M
HKS85	230	30	290.230.24M	291.230.36M	292.230.48M
<b>BLACK &amp; DECKER</b>					
BD855, KS855, U336, U975, U976	160	16	290.160.12E	291.160.24E	292.160.40E
SEC718, BD865E, KS865, P37-03, P37-05, DN229, DN59, DN820, HD1000, HD2062, SR300, SR362E, HD100, BD229	184	16	290.180.12E	291.184.24E	292.184.40E
DN800, SEC818, DN810, SR700, BD800	210	30	290.210.24M	291.210.36M	292.210.48M
P39-02, SEC918	235	30	290.235.24M	291.235.36M	292.235.48M
<b>BOSCH</b>					
1551, 1559	140	20		291.140.20H	
GKS12V, PKS46, S1, S33, GKS46	150	16		291.150.24E	
GKS54, PKS54	160	16	290.160.12E	291.160.24E	292.160.40E
GKS55, 1552, 1556, 1563	170	30		291.170.24M	292.170.40M
1550, 1557, 1560	180	30	290.180.12M	291.180.24M	292.180.40M
P30, P300, PKS65	190	16	290.190.12E	291.190.24E	292.190.40E
PKS66, GKS65, GKS66, GKS68, 0051, 1564, 1553	190	30	290.190.12M	291.190.24M	292.190.40M
1561	200	30	290.200.24M	291.200.36M	292.200.48M
1554, 1558, 1565, GKS75S	210	30	290.210.24M	291.210.36M	292.210.48M
0052, 1562, 1566					
GKS85S	230	30	290.230.24M	291.230.36M	292.230.48M
1555	240	30	290.240.24M	291.240.36M	292.240.48M
<b>CASALS</b>					
BSC150, VSC50	150	20	290.150.12H	291.150.24H	292.150.40H
SC210, VSC70	210	30	290.210.24M	291.210.36M	292.210.48M
SC230	230	30	290.230.24M	291.230.36M	292.230.48M

MACHINE	Blade diam. mm	Bore diam. mm	RIPPING ORDER NO.	UNIVERSAL ORDER NO.	FINE CUT OFF ORDER NO.
<b>DeWALT</b>					
DW351	150	20	290.150.12H	291.150.24H	292.150.40H
DW62	184	30	290.180.12M	291.184.24M	292.184.40M
DW65, DW365	190	30	290.190.12M	291.190.24M	292.190.40M
DW700, DW701, DW707	216	30	290.216.24M	291.216.48M	292.216.64M
DW383	235	30	290.235.24M	291.235.36M	292.235.48M
DW86	240	30	290.240.24M	291.240.36M	292.240.48M
DW250, DW252, DW320, 1251, 1501, 1503, DW710, DW125, DW150, DW720, DW742	250	30	290.250.24M	285.040.10M	285.060.10M
<b>ELEKTRA-BECKUM</b>					
KS250, KGS250, GKS300	250	30	290.250.24M	285.040.10M	285.060.10M
<b>ELU</b>					
MH151	150	20	290.150.12H	291.150.24H	292.150.40H
MH155, MH55	170	30		291.170.24M	292.170.40M
MH65	180	30	290.180.12M	291.180.24M	292.180.40M
MH165, 265	190	30	290.190.12M	291.190.24M	292.190.40M
MH182, MH30, MH82	210	30	290.210.24M	291.210.36M	292.210.48M
PS174, PS274	216	30	290.216.24M	291.216.48M	292.216.64M
MH85	240	30	290.240.24M	291.240.36M	292.240.48M
TKS171, 170, 171 172, 173	250	30	290.250.24M	285.040.10M	285.060.10M
<b>FEIN</b>					
SSK646	150	20	290.150.12H	291.150.24H	292.150.40H
SSK660	160	20	290.160.12H	291.160.24H	292.160.40H
SSK661	210	30	290.210.24M	291.210.36M	292.210.48M
<b>FELISATTI</b>					
TP751	150	20	290.150.12H	291.150.24H	292.150.40H
TP765, TP766	190	30	290.190.12M	291.190.24M	292.190.40M
<b>FESTO</b>					
AUF35, S4	125	20		291.125.20H	
ATF55, AP55	160	20	290.160.12H	291.160.24H	292.160.40H
AU50, AUP50, AAU	160	30		291.160.24M	292.160.40M
AT5E, AUT42S, AU42S, AXT50LA, AXT55	170	30		291.170.24M	292.170.40M
AU55S, AU60P, AU60S, AUT60S	180	30	290.180.12M	291.180.24M	292.180.40M
AD65, AU65S, AXP65, AP68E, AUT65S	200	30	290.200.24M	291.200.36M	292.200.48M
AU77S	220	30	290.220.24M	291.220.36M	292.220.48M
AXP85, AP88E, AP85E	240	30	290.240.24M	291.240.36M	292.240.48M
AD85-1, AE85	250	30	290.250.24M	285.040.10M	285.060.10M
<b>FLOTTJET</b>					
1011, 2011, 3011	250	30	290.250.24M	285.040.10M	285.060.10M
<b>FREUD</b>					
FCS184	184	30	290.180.12M	291.184.24M	292.184.40M
FTR250T	250	30	290.250.24M	285.040.10M	285.060.10M
<b>HAFFNER</b>					
KSU105	125	20		291.125.20H	
KSU50	160	20	290.160.12H	291.160.24H	292.160.40H
KSU110	170	30		291.170.24M	292.170.40M
KSU60	180	20		291.180.24H	292.180.40H

MACHINE	Blade diam. mm	Bore diam. mm	RIPPING ORDER NO.	UNIVERSAL ORDER NO.	FINE CUT OFF ORDER NO.
<b>HAFFNER</b>					
KSU113	180	30	290.180.12M	291.180.24M	292.180.40M
AKS	200	30	290.200.24M	291.200.36M	292.200.48M
KS75	210	30	290.210.24M	291.210.36M	292.210.48M
KL177, KL178, KSU118	220	30	290.220.24M	291.220.36M	292.220.48M
KL176, KS85, KSU85, SP187	235	30	290.235.24M	291.235.36M	292.235.48M
SP196, SP197, AKS, SP189, TGS161, TGS162					
TGS163, GS165, GS166, GS1, 2W, 2D, SP195, TGS198, GS150	250	30	290.250.24M	285.040.10M	285.060.10M
<b>HITACHI</b>					
C5Y	125	20		291.125.20H	
C5, FC5, FC5SA	150	20	290.150.12H	291.150.24H	292.150.40H
C6DA, FC6DA	160	20	290.160.12H	291.160.24H	292.160.40H
C6SA, PSU6	170	30		291.170.24M	292.170.40M
FC7SA, PSM-7, PSU-7	190	30	290.190.12M	291.190.24M	292.190.40M
C8U, C8FA, PSM-8, PSU-8	210	30	290.210.24M	291.210.36M	292.210.48M
C8FC	216	30	290.216.24M	291.216.48M	292.216.64M
C9U, PSM9, PSU9	235	30	290.235.24M	291.235.36M	292.235.48M
<b>HOLZ-HER</b>					
Derby, Mosquito, 2110, 2111, 2171	130	20		291.130.20H	
2260, 2270	140	20		291.140.20H	
2103, 2104, 2105, 2106, 2107, 2108, HKU50/264	160	20	290.160.12H	291.160.24H	292.160.40H
1563, 2115, 2266, 2271, 2281	170	30		291.170.24M	292.170.40M
HKU55, 2112, 2272, 2291	180	30	290.180.12M	291.180.24M	292.180.40M
2114, 2116, 2117, 2119, 2126, 2269, 2282	190	30	290.190.12M	291.190.24M	292.190.40M
HK201, 2113, 2292, 2555	200	30	290.200.24M	291.200.36M	292.200.48M
PKS267, 2267, 2284	210	30	290.210.24M	291.210.36M	292.210.48M
HKU75, 2274, 2279	220	30	290.220.24M	291.220.36M	292.220.48M
2118, 2120, 2171, 2293, 2294	230	30	290.230.24M	291.230.36M	292.230.48M
HKD65, 2268	240	30	290.240.24M	291.240.36M	292.240.48M
<b>KITY</b>					
0618	200	30	290.200.24M	291.200.36M	292.200.48M
<b>KRESS</b>					
CHKS 6055 /6050	160	20	290.160.12H	291.160.24H	292.160.40H
CHKS 6060 /1600	190	20	290.190.12H	291.190.24H	292.190.40H
<b>MAFELL</b>					
SF32, X40, XE40	125	20		291.125.20H	
MKS55, MS55, PS52, B55, FU50, X55, XE55, A55	160	20	290.160.12H	291.160.24H	292.160.40H
KS320	160	30		291.160.24M	292.160.40M
MKS65, MS65	190	30	290.190.12M	291.190.24M	292.190.40M

MACHINE	Blade diam. mm	Bore diam. mm	RIPPING ORDER NO.	UNIVERSAL ORDER NO.	FINE CUT OFF ORDER NO.
B65, X72	200	30	290.200.24M	291.200.36M	292.200.48M
HKS75, MS75	210	30	290.210.24M	291.210.36M	292.210.48M
B82	240	30	290.240.24M	291.240.36M	292.240.48M
MKS85, MS85, Erika 85	250	30	290.250.24M	285.040.10M	285.060.10M
<b>MAKITA</b>					
5600B	150	20	290.150.12H	291.150.24H	292.150.40H
5600NB, 5600RDW	160	20	290.160.12H	291.160.24H	292.160.40H
5800B, 5801B	180	20		291.180.24H	292.180.40H
5800BR	190	20	290.190.12H	291.190.24H	292.190.40H
5703R	190	30	290.190.12M	291.190.24M	292.190.40M
SR2100, LS0810	210	25	290.210.24L	291.210.36L	292.210.48L
SR2300, 5900B-R	235	25	290.235.24L	291.235.36L	292.235.48L
5903R	235	30	290.235.24M	291.235.36M	292.235.48M
<b>METABO</b>					
BTkO, KS0846S, KS0852S, 4341S, 61+2, KS52S, KS0946S	150	20	290.150.12H	291.150.24H	292.150.40H
BTk1, KS1155S	160	20	290.160.12H	291.160.24H	292.160.40H
6317S	180	20		291.180.24H	292.180.40H
KS4345S, 5348, KS4346S, KS65S, KS1468, KSE1668					
KS1266S	190	20	290.190.12H	291.190.24H	292.190.40H
KSE1678 KGS1670	210	30	290.210.24M	291.210.36M	292.210.48M
6322-S	220	30	290.220.24M	291.220.36M	292.220.48M
KS6323, KS1785S	240	30	290.240.24M	291.240.36M	292.240.48M
TK168S, TK1685, TK1688, TKU1633, TKU1693	250	30	290.250.24M	285.040.10M	285.060.10M
<b>PERLES</b>					
KS 50	150	20	290.150.12H	291.150.24H	292.150.40H
KS 70	210	30	290.210.24M	291.210.36M	292.210.48M
<b>RYOBI</b>					
MS 50	150	16		291.150.24E	
MS45, MS45E	150	20	290.150.12H	291.150.24H	292.150.40H
FM, W5502C	160	16	290.160.12E	291.160.24E	292.160.40E
MS 55	160	20	290.160.12H	291.160.24H	292.160.40H
MS 65	190	30	290.190.12M	291.190.24M	292.190.40M
MS 70	200	30	290.200.24M	291.200.36M	292.200.48M
MS 85, MS 80	220	30	290.220.24M	291.220.36M	292.220.48M
MS 85	230	30	290.230.24M	291.230.36M	292.230.48M
FM10A, 3100, 4200	240	30	290.240.24M	291.240.36M	292.240.48M
<b>SKIL</b>					
5246S	150	16		291.150.24E	
1850, 1850 H	150	20	290.150.12H	291.150.24H	292.150.40H
416, 534, 536, 552	160	16	290.160.12E	291.160.24E	292.160.40E
77, 537, 553, BIH, 559, 574, 857, 1865	184	16		291.184.24E	292.184.40E
1865, 5266, 5366, 5466	190	16	290.190.12E	291.190.24E	292.190.40E
1965, 5566, 5666	190	30	290.190.12M	291.190.24M	292.190.40M
1524H, 1873H	210	30	290.210.24L	291.210.36L	292.210.48L
1525, 1886, 1985, 1986	235	30	290.235.24M	291.235.36M	292.235.48M
<b>STAYER</b>					
Profiline, CP 46	140	20		291.140.20H	
CP 50	150	20	290.150.12H	291.150.24H	292.150.40H
SLL250, SCE250, CP66	250	30	290.250.24M	285.040.10M	285.060.10M



D Blade diam. mm	F Bore diam. mm	Application	Z No. of teeth	K Kerf thick. mm	P Plate thick. mm	α Hook angle	β Type of grind	ORDER NO.	Page
100	20	Panel sizing	10+10	2,8-3,6			FLAT	289.100.20H	167
100	22	Panel sizing	10+10	2,8-3,6			FLAT	289.100.20K	167
100	20	Panel sizing	20	3,1-4			CONICAL	288.100.20H	167
100	22	Panel sizing	20	3,1-4			CONICAL	288.100.20K	167
100	22	Grooving	4	8	6	18°		240.004.04	181
100	22	Grooving	6	3,96	2,8	15°	15° ATB	240.006.04	181
100	22	Grooving	8	3,96	2,8	15°	15° ATB	240.008.04	181
100	22	Grooving	8	3,96	3,1	15°	15° ATB	241.008.04	181
120	20	Panel sizing	12+12	2,8-3,6			FLAT	289.120.24H	167
120	22	Panel sizing	12+12	2,8-3,6			FLAT	289.120.24K	167
120	20	Panel sizing	24	3,1-4			CONICAL	288.120.24H	167
120	22	Panel sizing	24	3,1-4			CONICAL	288.120.24K	167
125	20	Panel sizing	12+12	2,8-3,6			FLAT	289.125.24H	167
125	22	Panel sizing	12+12	2,8-3,6			FLAT	289.125.24K	167
125	20	Portables machines	20	2,4	1,4	15°	15° ATB	291.125.20H	177
125	20	Panel sizing	24	3,1-4			CONICAL	288.125.24H	167
125	20	Panel sizing	24	4,3-5,5			CONICAL	288.125.24H2	167
125	22	Panel sizing	24	3,1-4			CONICAL	288.125.24K	167
125	45	Panel sizing	24	4,3-5,5			CONICAL	288.125.24Q	167
130	16	Portables machines	12	1,3	0,8	25°	1 FTG+2/20° ATB	271.130.12E	174
130	20	Portables machines	20	2,4	1,4	15°	15° ATB	291.130.20H	177
136	10	Portables machines	18	1,5	1	20°	1 FTG+2/20° ATB	271.136.18D	174
136	10	Portables machines	18	1,5	1	20°	1FTG+2/20° ATB	271.136.18D	179
136	10	Metal	30	1,5	1,2	0°	TCG	226.030.05	172
136	10	Metal	30	1,5	1,2	0°	TCG	226.030.05	179
136	10	Portables machines	36	1,3	0,8	20°	1 FTG+2/15° ATB	272.136.36D	175
136	10	Portables machines	36	1,3	0,8	20°	1FTG+2/15° ATB	272.136.36D	179
140	20	Portables machines	20	2,4	1,4	15°	15° ATB	291.140.20H	177
140	16	Panel sizing	24	3,1-4			CONICAL	Y288.140.24E	167
150	20	Portables machines	12	2,4	1,4	20°	10° ATB	290.150.12H	176
150	30	Grooving	12	2	1,4	15°	FLAT	240.020.06M	180
150	30	Grooving	12	3	2	15°	FLAT	240.030.06M	180
150	30	Grooving	12	4	3	15°	FLAT	240.040.06M	180
150	30	Grooving	12	5	3	15°	FLAT	240.050.06M	180
150	30	Grooving	12	6	3	15°	FLAT	240.060.06M	180
150	35	Grooving	12	2	1,4	15°	FLAT	240.020.06R	180
150	35	Grooving	12	3	2	15°	FLAT	240.030.06R	180
150	35	Grooving	12	4	3	15°	FLAT	240.040.06R	180
150	35	Grooving	12	5	3	15°	FLAT	240.050.06R	180
150	35	Grooving	12	6	3	15°	FLAT	240.060.06R	180
150	20	Portables machines	18	1,3	0,8	20°	1 FTG+2/20° ATB	271.150.18H	179
150	15,87	Grooving	20	3,2		-5°	FTG+ATB	230.520.06	182
150	16	Portables machines	24	2,4	1,4	15°	15° ATB	291.150.24E	177
150	20	Portables machines	24	2,4	1,4	15°	15° ATB	291.150.24H	177
150	45	Panel sizing	36	4,3-5,5			CONICAL	288.150.36Q	167
150	20	Portables machines	40	2,4	1,4	15°	15° ATB	292.150.40H	178
150	30	Wood	48	3,2	2,2	5°	15° ATB	285.048.06M	163
160	16	Portables machines	12	2,6	1,6	20°	10° ATB	290.160.12E	176
160	20	Portables machines	12	2,6	1,6	20°	10° ATB	290.160.12H	176
160	16	Portables machines	18	1,3	0,8	20°	1 FTG+2/20° ATB	271.160.18E	174
160	20	Portables machines	18	1,3	0,8	20°	1 FTG+2/20° ATB	271.160.18H	174
160	16	Portables machines	24	2,6	1,6	15°	15° ATB	291.160.24E	177
160	20	Portables machines	24	2,6	1,6	15°	15° ATB	291.160.24H	177
160	30	Portables machines	24	2,6	1,6	15°	15° ATB	291.160.24M	177
160	20	Metal	30	2	1,6	0°	TCG	226.030.06H	172
160	45	Panel sizing	36	4,3-5,5			CONICAL	288.160.36Q	167
160	55	Panel sizing	36	4,3-5,5			CONICAL	288.160.360	167
160	55	Panel sizing	36	4,7-6,0			CONICAL	Y288.160.3602	167
160	20	Abrasive materials	4	2,2	1,6	12°	FLAT	236.160.04H	179
160	16	Portables machines	40	2,6	1,6	10°	15° ATB	292.160.40E	178
160	20	Portables machines	40	2,4	1,6	10°	TCG	281.160.40H	165
160	20	Aluminium	40	2,8	2,2	-6° Neg.	TCG	296.160.40H	171
160	20	Portables machines	40	2,6	1,6	10°	15° ATB	292.160.40H	178
160	20	Wood Composites	40	2,4	1,6	10°	TCG	281.160.40H	178
160	30	Portables machines	40	2,6	1,6	10°	15° ATB	292.160.40M	178
160	20	Aluminium	56	2,8	2,2	-6° Neg.	TCG	296.160.56H	171
160	20	Portables machines	56	2,6	1,6	15°	15° ATB	292.160.56H	178
165	16	Portables machines	18	1,3	0,8	20°	1 FTG+2/20° ATB	271.165.18	174
165	16	Portables machines	18	1,3	0,8	20°	1FTG+2/20° ATB	271.165.18	179
165	20	Portables machines	24	2,6	1,6	15°	15° ATB	291.165.24H	177
165	20	Portables machines	24	1,3	0,8	20°	1FTG+2/20° ATB	271.165.24H	174
165	20	Portables machines	24	1,3	0,8	20°	1FTG+2/20° ATB	271.165.24H	179
165	30	Portables machines	24	2,6	1,6	15°	15° ATB	291.165.24M	177
165	15,87	Metal	36	1,5	1,2	0°	TCG	226.036.06	172
165	16	Portables machines	36	1,3	0,8	20°	1 FTG+2/20° ATB	272.165.36	175
165	16	Portables machines	36	1,3	0,8	20°	1FTG+2/20° ATB	272.165.36	179
165	16	Metal	36	1,5	1,2	0°	TCG	226.036.06	179
165	20	Metal	36	1,5	1,2	0°	TCG	226.036.06H	172

D Blade diam. mm	F Bore diam. mm	Application	Z No. of teeth	K Kerf thick. mm	P Plate thick. mm	α Hook angle	β Type of grind	ORDER NO.	Page
165	20	Portables machines	36	1,3	0,8	20°	1FTG+2/20° ATB	272.165.36H	175
165	20	Portables machines	36	1,3	0,8	20°	1FTG+2/20° ATB	272.165.36H	179
165	20	Portables machines	40	2,6	1,6	10°	15° ATB	292.165.40H	178
165	30	Portables machines	40	2,6	1,6	15°	15° ATB	292.165.40M	178
170	30	Portables machines	24	2,6	1,6	20°	10° ATB	291.170.24M	177
170	30	Portables machines	40	2,6	1,6	15°	15° ATB	292.170.40M	178
180	20	Panel sizing	10+10	2,8-3,6			FLAT	289.080.20H	167
180	30	Portables machines	12	2,6	1,6	20°	10° ATB	290.180.12M	176
180	30	Grooving	18	3	2	15°	FLAT	240.030.07M	180
180	30	Grooving	18	4	3	15°	FLAT	240.040.07M	180
180	30	Grooving	18	5	3	15°	FLAT	240.050.07M	180
180	30	Grooving	18	6	3	15°	FLAT	240.060.07M	180
180	35	Grooving	18	3	2	15°	FLAT	240.030.07R	180
180	35	Grooving	18	4	3	15°	FLAT	240.040.07R	180
180	35	Grooving	18	5	3	15°	FLAT	240.050.07R	180
180	35	Grooving	18	6	3	15°	FLAT	240.060.07R	180
180	40	Multirip	21+3	2,5	1,8	20°	FLAT	280.021.07S	159
180	20	Portables machines	24	2,6	1,6	20°	10° ATB	291.180.24H	177
180	30	Portables machines	24	2,6	1,6	20°	10° ATB	291.180.24M	177
180	20	Panel sizing	36	4,3-5,5			CONICAL	Y288.180.36H	167
180	20	Panel sizing	36	4,3-5,5			CONICAL	288.180.36H	167
180	30	Panel sizing	36	4,3-5,5			CONICAL	288.180.36M	167
180	45	Panel sizing	36	4,7-6,0			CONICAL	288.180.36Q	167
180	55	Panel sizing	36	5,0-6,2			CONICAL	288.180.36Q	167
180	20	Abrasive materials	4	2,2	1,6	12°	FLAT	236.180.04H	179
180	20	Aluminium	40	2,8	2,2	-6° Neg.	TCG	296.180.40H	171
180	20	Portables machines	40	2,6	1,6	15°	15° ATB	292.180.40H	178
180	30	Portables machines	40	2,6	1,6	15°	15° ATB	292.180.40M	178
180	50	Panel sizing	44	4,3-5,5			CONICAL	288.180.44T	167
180	30	Wood	56	3,2	2,2	5°	15° ATB	285.056.07M	163
184	15,87	Portables machines	24	1,9	1,2	20°	1FTG+2/20° ATB	250.024.07	182
184	15,87	Portables machines	24	1,9	1,2	20°	1FTG+2/20° ATB	250.024.07-X10	182
184	16	Portables machines	24	2,6	1,6	20°	10° ATB	291.184.24E	177
184	16	Portables machines	24	1,3	0,8	20°	1 FTG+2/20° ATB	271.184.24E	174
184	16	Portables machines	24	1,3	0,8	20°	1FTG+2/20° ATB	271.184.24E	179
184	20	Portables machines	24	1,3	0,8	20°	1 FTG+2/20° ATB	271.184.24H	174
184	30	Portables machines	24	2,6	1,6	20°	10° ATB	291.184.24M	177
184	30	Portables machines	24	1,3	0,8	20°	1 FTG+2/20° ATB	271.184.24M	174
184	15,87	Abrasive materials	4	2,2	1,6	12°	FLAT	236.004.07	179
184	15,87	Portables machines	40	1,9	1,2	20°	1FTG+4/20° ATB	251.040.07	182
184	15,87	Portables machines	40	1,9	1,2	20°	1FTG+4/20° ATB	251.040.07-X10	182
184	16	Portables machines	40	2,6	1,6	15°	15° ATB	292.184.40E	178
184	30	Portables machines	40	2,6	1,6	15°	15° ATB	292.184.40M	178
184	30	Portables machines	42	1,3	0,8	20°	1 FTG+2/20° ATB	272.184.42M	175
184	15,87	Metal	48	2	1,6	0°	TCG	226.048.07	172
190	16	Portables machines	12	2,6	1,6	20°	10° ATB	290.190.12E	176
190	20	Portables machines	12	2,6	1,6	20°	10° ATB	290.190.12H	176
190	30	Portables machines	12	2,6	1,6	20°	10° ATB	290.190.12M	176
190	16	Portables machines	24	2,6	1,6	20°	10° ATB	291.190.24E	177
190	20	Portables machines	24	2,6	1,6	20°	10° ATB	291.190.24H	177
190	30	Portables machines	24	2,6	1,6	20°	10° ATB	291.190.24M	177
190	30	Portables machines	24	1,5	1	20°	1 FTG+2/20° ATB	271.190.24M	174
190	Festool® FF	Portables machines	32	2,6	1,6	10°	10° ATB	291.190.32FF	177
190	30	Abrasive materials	4	2,2	1,6	12°	FLAT	236.190.04M	179
190	16	Portables machines	40	2,6	1,6	15°	15° ATB	292.190.40E	178
190	20	Portables machines	40	2,6	1,6	15°	15° ATB	292.190.40H	178
190	30	Aluminium	40	2,8	2,2	-6° Neg.	TCG	296.190.40M	171
190	30	Portables machines	40	2,6	1,6	15°	15° ATB	292.190.40M	178
190	30	Metal	40	2	1,6	0°	TCG	226.040.07M	172
190	Festool® FF	Portables machines	48	2,4	1,6	10°	15° ATB	292.190.48FF	178
190	30	Aluminium	64	2,8	2,2	-6° Neg.	TCG	296.190.64M	171
190	30	Portables machines	64	2,6	1,6	15°	15° ATB	292.190.64M	178
190	Festool® FF	Aluminium	64	2,8	2,2	-6° Neg.	TCG	296.190.64FF	171
200	15,87	Grooving	12	3,2		-12°	FTG+ATB	230.012.08	182
200	40	Multirip	21+3	2,5	1,8	20°	FLAT	280.021.08S	159
200	15,87	Grooving	24	3,2		-5°	FTG+ATB	230.524.08	182
200	30	Portables machines	24	2,8	1,8	20°	10° ATB	290.200.24M	176
200	30	Grooving	24	3,2		-5°	FTG+ATB	230.524.08M	182
200	20	Panel sizing	36	4,3-5,5			CONICAL	288.200.36H	167
200	30	Wood	36	3,2	2,2	15°	10° ATB	285.036.08M	162
200	30	Portables machines	36	1,7	1,2	20°	1 FTG+2/15° ATB	271.200.36M	174
200	30	Portables machines	36	2,8	1,8	15°	15° ATB	291.200.36M	177
200	45	Panel sizing	36	4,7-6,0			CONICAL	288.200.36Q	167
200	65	Panel sizing	36	4,3-5,5			CONICAL	288.200.36J	167
200	30	Wood	48	3,2	2,2	15°	15° ATB	285.048.08M	162
200	30	Aluminium	48	2,8	2,2	-6° Neg.	TCG	296.200.48M	171
200	30	Portables machines	48	2,8	1,8	15°	15° ATB	292.200.48M	178
200	30	Wood	64	3,2	2,2	5°	15° ATB	285.064.08M	163

D Blade diam. mm	F Bore diam. mm	Application	Z No. of teeth	K Kerf thick. mm	P Plate thick. mm	α Hook angle	β Type of grind	ORDER NO.	Page
200	30	Wood Composites	64	3,2	2,2	10°	TCG	281.064.08M	165
210	25	Portables machines	24	2,8	1,8	20°	10° ATB	290.210.24L	176
210	30	Portables machines	24	2,8	1,8	20°	10° ATB	290.210.24M	176
210	25	Portables machines	36	2,8	1,8	15°	15° ATB	291.210.36L	177
210	30	Portables machines	36	2,8	1,8	15°	15° ATB	291.210.36M	177
210	15,87	Metal	48	2,2	1,8	0°	TCG	226.048.08	172
210	25	Portables machines	48	2,8	1,8	15°	15° ATB	292.210.48L	178
210	30	Aluminium	48	2,8	2,2	-6° Neg.	TCG	296.210.48M	171
210	30	Portables machines	48	2,8	1,8	15°	15° ATB	292.210.48M	178
210	30	Metal	48	2,2	1,8	0°	TCG	226.048.08M	172
210	30	Aluminium	64	2,8	2,2	-6° Neg.	TCG	296.210.64M	171
210	30	Portables machines	64	2,8	1,8	15°	15° ATB	292.210.64M	178
215	50	Panel sizing	42	4,3-5,5			CONICAL	288.215.42T	167
216	30	Portables machines	24	2,8	1,8	-5° Neg.	15° ATB	290.216.24M	176
216	30	Portables machines	36	1,7	1,2	20°	1 FTG+2/15° ATB	271.216.36M	174
216	30	Portables machines	48	2,8	1,8	-5° Neg.	15° ATB	291.216.48M	177
216	30	Aluminium	64	2,8	2,5	-6° Neg.	TCG	297.064.09M	171
216	30	Portables machines	64	2,8	1,8	-5° Neg.	15° ATB	292.216.64M	178
220	30	Portables machines	24	2,8	1,8	20°	10° ATB	290.220.24M	176
220	30	Portables machines	36	2,8	1,8	15°	15° ATB	291.220.36M	177
220	30	Wood Composites	42	3,2	2,2	10°	HDF	287.042.09M	166
220	30	Portables machines	48	2,8	1,8	15°	15° ATB	292.220.48M	178
220	30	Wood Composites	64	3,2	2,2	-5°	40° ATB	283.064.09M	164
220	30	Wood Composites	64	3,2	2,2	10°	TCG	281.064.09M	165
225	30	Portables machines	36	2,8	1,8	20°	15° ATB	291.225.36M	177
225	30	Portables machines	48	2,8	1,8	10°	15° ATB	292.225.48M	178
225	30	Aluminium	64	2,8	2,2	-6° Neg.	TCG	296.225.64M	171
230	30	Portables machines	24	2,8	1,8	20°	10° ATB	290.230.24M	176
230	30	Portables machines	36	2,8	1,8	15°	15° ATB	291.230.36M	177
230	30	Abrasive materials	4	2,2	1,6	12°	FLAT	236.230.04M	179
230	30	Aluminium	48	2,8	2,2	-6° Neg.	TCG	296.230.48M	171
230	30	Portables machines	48	2,8	1,8	15°	15° ATB	292.230.48M	178
230	30	Portables machines	64	2,8	1,87	15°	15° ATB	292.230.64M	178
235	25	Portables machines	24	2,8	1,8	20°	10° ATB	290.235.24L	176
235	30	Portables machines	24	2,8	1,8	20°	10° ATB	290.235.24M	176
235	25	Portables machines	36	2,8	1,8	15°	15° ATB	291.235.36L	177
235	25	Portables machines	36	1,7	1,2	20°	1 FTG+2/15° ATB	271.235.36L	174
235	30	Portables machines	36	2,8	1,8	15°	15° ATB	291.235.36M	177
235	30	Portables machines	36	1,7	1,2	20°	1 FTG+2/15° ATB	271.235.36M	174
235	25	Portables machines	48	2,8	1,8	15°	15° ATB	292.235.48L	178
235	30	Aluminium	48	2,8	2,2	-6° Neg.	TCG	296.235.48M	171
235	30	Portables machines	48	2,8	1,8	15°	15° ATB	292.235.48M	178
235	30	Metal	48	2,2	1,8	0°	TCG	226.048.09M	172
240	30	Portables machines	24	2,8	1,8	20°	10° ATB	290.240.24M	176
240	30	Portables machines	36	2,8	1,8	15°	15° ATB	291.240.36M	177
240	30	Portables machines	48	2,8	1,8	15°	15° ATB	292.240.48M	178
250	30	Construction	16	2,8	1,8	15°	5° ATB	286.016.10M	161
250	20	Garden	20	2,2	1,8	25°	ATB	298.250.20H	176
250	25,4	Garden	20	2,2	1,8	25°	ATB	298.250.20	176
250	30	Multirip	20+4	3,2	2,2	20°	5° ATB	279.020.10M	160
250	70	Multirip	20+4	2,7	1,8	20°	5° ATB	280.020.10V	159
250	70	Multirip	20+4	3,2	2,2	20°	5° ATB	279.020.10V	160
250	80	Multirip	20+4	2,7	1,8	20°	5° ATB	280.020.10W	159
250	80	Multirip	20+4	3,2	2,2	20°	5° ATB	279.020.10W	160
250	30	Wood	24	2,8	1,8	20°	10° ATB	290.250.24M	161
250	30	Portables machines	24	2,8	1,8	20°	10° ATB	290.250.24M	176
250	30	Portables machines	24	1,7	1,2	20°	1 FTG+2/15° ATB	271.250.24M	174
250	20	Wood	40	3,2	2,2	15°	10° ATB	285.040.10H	162
250	20	Wood	40	3,2	2,2	15°	10° ATB	285.040.10H	177
250	30	Wood	40	3,2	2,2	15°	10° ATB	285.040.10M	162
250	30	Wood	40	3,2	2,2	15°	10° ATB	285.040.10M	177
250	35	Wood	40	3,2	2,2	15°	10° ATB	285.040.10R	162
250	30	Portables machines	42	1,7	1,2	20°	1 FTG+2/15° ATB	271.250.42M	174
250	30	Wood	48	3,2	2,2	15°	10° ATB	285.048.10M	162
250	30	Wood Composites	48	3,2	2,2	10°	HDF	287.048.10M	166
250	30	Wood	60	3,2	2,2	10°	15° ATB	285.060.10M	162
250	30	Wood Composites	60	3,2	2,2	10°	TCG	281.060.10M	165
250	30	Wood Composites	60	3,2	2,2	-6°	TCG	281.061.10M	166
250	30	Wood Composites	60	3,2	2,2	10°	TCG	281.060.10M	169
250	30	Wood	60	3,2	2,2	10°	15° ATB	285.060.10M	178
250	30	Portables machines	60	1,7	1,2	20°	1 FTG+2/15° ATB	272.250.60M	175
250	35	Wood	60	3,2	2,2	10°	15° ATB	285.060.10R	162
250	30	Solid surface	72	3,2	2,5	0°	MTCG	223.072.10M	173
250	30	Wood	80	3,2	2,2	5°	15° ATB	285.080.10M	163
250	30	Wood	80	3	2,5	10°	20° ATB	285.580.10M	163
250	30	Wood Composites	80	3,2	2,2	-2°	40° ATB	283.080.10M	164
250	30	Wood Composites	80	3,2	2,2	5°	40° ATB	210.080.10M	164
250	30	Wood Composites	80	3,2	2,2	10°	TCG	281.080.10M	165

D Blade diam. mm	F Bore diam. mm	Application	Z No. of teeth	K Kerf thick. mm	P Plate thick. mm	α Hook angle	β Type of grind	ORDER NO.	Page
250	30	Wood Composites	80	3,2	2,2	10°	TCG	281.580.10M	165
250	30	Wood Composites	80	3,2	2,2	10°	TCG	281.080.10M	169
250	30	Aluminium	80	3,2	2,5	-6° Neg.	TCG	297.080.10M	171
250	30	Plexiglass & plastic	80	2,8	2,2	-3°	MATB	222.080.10M	173
250	30	Portables machines	80	1,7	1,2	15°	40°_ATB	273.250.80M	175
250	32	Aluminium	80	3,2	2,5	5° Pos.	TCG	284.080.10P	170
250	32	Aluminium	80	3,2	2,5	-6° Neg.	TCG	297.080.10P	171
250	35	Wood	80	3,2	2,2	5°	15° ATB	285.080.10R	163
254	15,87	Abrasive materials	6	2,2	1,6	12°	FLAT	236.006.10	179
254	15,87	Metal	60	2,2	1,8	0°	8° FWF	226.060.10	172
254	30	Metal	60	2,2	1,8	0°	8° FWF	226.060.10M	172
260	30	Wood	48	3,2	2,2	15°	10° ATB	285.048.11M	162
260	30	Wood	48	3,2	2,2	15°	10° ATB	285.048.11M	177
260	30	Wood	60	3,2	2,2	10°	15° ATB	285.060.11M	162
260	30	Wood	60	3,2	2,2	10°	15° ATB	285.060.11M	178
260	30	Aluminium	80	3,2	2,5	-6° Neg.	TCG	297.080.11M	171
270	30	Wood	28	2,8	1,8	15°	10° ATB	290.270.28M	161
270	30	Portables machines	28	2,8	1,8	20°	10°_ATB	290.270.28M	176
270	30	Portables machines	42	2,8	1,8	15°	15° ATB	291.270.42M	162
270	30	Portables machines	42	2,8	1,8	15°	15° ATB	291.270.42M	177
275	20	Wood	42	3,2	2,2	15°	10° ATB	285.042.11H	162
280	30	Wood	64	2,8	1,8	10°	15° ATB	295.064.11M	162
280	30	Aluminium	64	3,2	2,5	-6° Neg.	TCG	297.064.11M	171
300	30	Construction	20	2,8	1,8	15°	5° ATB	286.020.12M	161
300	30	Wood	24	3,2	2,2	20°	10° ATB	293.024.12M	161
300	30	Multirip	24+4	3,2	2,2	20°	5° ATB	279.024.12M	160
300	60	Multirip	24+4	3,2	2,2	20°	5°_ATB	279.024.12U	160
300	70	Multirip	24+4	2,7	1,8	20°	5° ATB	280.024.12V	159
300	70	Multirip	24+4	3,2	2,2	20°	5° ATB	279.024.12V	160
300	80	Multirip	24+4	2,7	1,8	20°	5° ATB	280.024.12W	159
300	80	Multirip	24+4	3,2	2,2	20°	5°_ATB	279.024.12W	160
300	30	Multirip	24+4	4	2,8	18°	10°_ATB	277.024.12M	159
300	70	Multirip	24+4	4	2,8	18°	10°_ATB	277.024.12V	159
300	80	Multirip	24+4	4	2,8	18°	10°_ATB	277.024.12W	159
300	30	Multirip	28	3,2	2,2	20°	5° ATB	278.028.12M	160
300	70	Multirip	28	3,2	2,2	20°	5° ATB	278.028.12V	160
300	30	Portables machines	45	2,4	1,8	20°	1 FTG+2/15°_ATB	271.300.45M	174
300	20	Wood	48	3,2	2,2	15°	10° ATB	285.048.12H	162
300	30	Wood	48	3,2	2,2	15°	10° ATB	285.048.12M	162
300	35	Wood	48	3,2	2,2	15°	10° ATB	285.048.12R	162
300	50	Panel sizing	48	4,3-5,5			CONICAL	288.300.48T	167
300	30	Wood	60	3,2	2,2	15°	10° ATB	285.060.12M	162
300	30	Panel sizing	60	4,4	3,2	16°	TCG	282.060.12M	169
300	75	Panel sizing	60	4,4	3,2	16°	TCG	282.060.12X	169
300	80	Panel sizing	60	4,4	3,2	16°	TCG	282.060.12W	169
300	30	Wood	72	3,2	2,2	10°	15° ATB	285.072.12M	162
300	30	Wood Composites	72	3,2	2,2	10°	TCG	281.072.12M	165
300	30	Wood Composites	72	3,2	2,2	-6°	TCG	281.073.12M	166
300	30	Wood Composites	72	3,2	2,2	10°	TCG	281.072.12M	169
300	30	Portables machines	72	2,4	1,8	20°	1 FTG+2/15°_ATB	272.300.72M	175
300	35	Wood	72	3,2	2,2	10°	15° ATB	285.072.12R	162
300	65	Panel sizing	72	4,3-5,5			CONICAL	288.300.72J	167
300	30	Solid surface	84	3,2	2,5	0°	MTCG	223.084.12M	173
300	30	Wood	96	3,2	2,2	5°	15° ATB	285.096.12M	163
300	30	Wood	96	3	2,5	10°	20° ATB	285.596.12M	163
300	30	Wood Composites	96	3,2	2,2	2°	40° ATB	283.096.12M	164
300	30	Wood Composites	96	3,2	2,2	5°	40° ATB	210.096.12M	164
300	30	Wood Composites	96	3,2	2,2	10°	TCG	281.096.12M	165
300	30	Wood Composites	96	3,2	2,2	10°	TCG	281.596.12M	165
300	30	Wood Composites	96	3,2	2,2	10°	TCG	281.096.12M	169
300	30	Aluminium	96	3,2	2,5	-6° Neg.	TCG	297.096.12M	171
300	30	Plexiglass & plastic	96	2,8	2,2	-3°	MATB	222.096.12M	173
300	30	Portables machines	96	2,4	1,8	15°	40°_ATB	273.300.96M	175
300	32	Aluminium	96	3,2	2,5	5° Pos.	TCG	284.096.12P	170
300	32	Aluminium	96	3,2	2,5	-6° Neg.	TCG	297.096.12P	171
300	35	Wood	96	3,2	2,2	5°	15° ATB	285.096.12R	163
303	30	Wood Composites	60	3,2	2,2	10°	HDF	287.060.12M	166
305	30	Wood	28	2,8	1,8	20°	10° ATB	293.028.22M	161
305	30	Wood	54	2,8	1,8	-5° Neg.	15° ATB	294.054.22M	162
305	25,4	Metal	60	2,2	1,8	0°	8° FWF	226.060.12	172
305	30	Wood	72	3,2	2,2	5°	15° ATB	285.072.22M	163
305	25,4	Abrasive materials	8	2,2	1,6	12°	FLAT	236.008.12	179
305	25,4	Metal	80	2,2	1,8	0°	8° FWF	226.080.12	172
305	30	Metal	80	2,2	1,8	0°	8° FWF	226.080.12M	172
305	30	Aluminium	96	3,2	2,5	-6° Neg.	TCG	297.096.13M	171
315	30	Construction	24	3,2	2,2	15°	5° ATB	286.024.13M	161
315	30	Wood	28	3,2	2,2	20°	10° ATB	293.028.12M	161
315	30	Wood	36	3,2	1,8	15°	10° ATB	285.036.13M	162



D Blade diam. mm	F Bore diam. mm	Application	Z No. of teeth	K Kerf thick. mm	P Plate thick. mm	α Hook angle	β Type of grind	ORDER NO.	Page
315	30	Wood	54	3,2	1,8	15°	10° ATB	294.054.12M	162
315	30	Wood	72	3,2	2,2	5°	15° ATB	285.072.13M	163
315	30	Aluminium	96	3,2	2,5	-6° Neg.	TCG	297.096.23M	171
350	30	Wood	108	3,5	2,5	5°	15° ATB	285.108.14M	163
350	30	Wood Composites	108	3,5	2,5	5°	40° ATB	283.108.14M	164
350	30	Wood Composites	108	3,5	2,5	10°	TCG	281.108.14M	165
350	30	Wood Composites	108	3,5	2,5	10°	TCG	281.608.14M	165
350	30	Wood Composites	108	3,5	2,5	10°	TCG	281.108.14M	169
350	30	Aluminium	108	3,2	2,5	-6° Neg.	TCG	297.108.14M	171
350	32	Aluminium	108	3,2	2,5	5° Pos.	TCG	284.108.14P	170
350	32	Aluminium	108	3,2	2,5	-6° Neg.	TCG	297.108.14P	171
350	35	Wood	108	3,5	2,5	5°	15° ATB	285.108.14R	163
350	30	Construction	24	3,2	2,2	15°	5° ATB	286.024.14M	161
350	30	Multirip	24+6	4,2	2,8	18°	10° ATB	277.024.14M	159
350	70	Multirip	24+6	4,2	2,8	18°	10° ATB	277.024.14V	159
350	30	Wood	28	3,5	2,5	20°	10° ATB	293.028.14M	161
350	30	Multirip	28+4	3,5	2,5	20°	5° ATB	279.028.14M	160
350	60	Multirip	28+4	3,5	2,5	20°	5° ATB	279.028.14U	160
350	70	Multirip	28+4	3,5	2,5	20°	5° ATB	279.028.14V	160
350	80	Multirip	28+4	3,5	2,5	20°	5° ATB	279.028.14W	160
350	30	Multirip	36	3,5	2,5	20°	5° ATB	278.036.14M	160
350	70	Multirip	36	3,5	2,5	20°	5° ATB	278.036.14V	160
350	30	Wood	54	3,5	2,5	15°	10° ATB	285.054.14M	162
350	35	Wood	54	3,5	2,5	15°	10° ATB	285.054.14R	162
350	30	Wood	72	3,5	2,5	15°	10° ATB	285.072.14M	162
350	30	Panel sizing	72	4,4	3,2	16°	TCG	282.072.14M	169
350	50	Panel sizing	72	4,4	3,2	16°	TCG	282.072.14T	169
350	75	Panel sizing	72	4,4	3,2	16°	TCG	282.072.14X	169
350	80	Panel sizing	72	4,4	3,2	16°	TCG	282.072.14W	169
350	30	Wood	84	3,5	2,5	10°	15° ATB	285.084.14M	162
350	35	Wood	84	3,5	2,5	10°	15° ATB	285.084.14R	162
350	32	Aluminium	92	3,2	2,5	5° Pos.	TCG	284.092.14P	170
355	25,4	Metal	80	2,2	1,8	0°	8° FWF	226.080.14	172
355	25,4	Metal	90	2,2	1,8	0°	8° FWF	226.090.14	172
355	30	Metal	90	2,2	1,8	0°	8° FWF	226.090.14M	172
380	60	Panel sizing	72	4,8	3,5	16°	TCG	282.072.15U	169
400	32	Aluminium	108	3,8	3,2	-6° Neg.	TCG	297.108.16P	171
400	30	Wood	120	3,5	2,5	10°	15° ATB	285.120.16M	163
400	30	Construction	28	3,2	2,2	15°	5° ATB	286.028.16M	161
400	30	Multirip	28+6	4	2,8	20°	5° ATB	279.028.16M	160
400	70	Multirip	28+6	4	2,8	20°	5° ATB	279.028.16V	160
400	30	Wood	36	3,5	2,5	20°	10° ATB	285.036.16M	161
400	30	Wood	48	3,5	2,5	20°	10° ATB	285.048.16M	162
400	30	Wood	60	3,5	2,5	10°	15° ATB	285.060.16M	162
400	30	Panel sizing	72	4,4	3,2	16°	TCG	282.072.16M	169
400	60	Panel sizing	72	4,4	3,2	16°	TCG	282.072.16U	169
400	75	Panel sizing	72	4,4	3,2	16°	TCG	282.072.16X	169
400	80	Panel sizing	72	4,4	3,2	16°	TCG	282.072.16W2	169
400	80	Panel sizing	72	4,4	3,2	16°	TCG	282.072.16W	169
400	30	Wood	96	3,5	2,5	5°	15° ATB	285.096.16M	163
400	32	Aluminium	96	3,8	3,2	5° Pos.	TCG	284.096.16P	170
420	32	Aluminium	96	3,8	3,2	5° Pos.	TCG	284.096.17P	170
430	75	Panel sizing	72	4,4	3,2	16°	TCG	282.072.17X	169
430	80	Panel sizing	72	4,4	3,2	16°	TCG	282.072.17W2	169
450	32	Aluminium	108	3,8	3,2	5° Pos.	TCG	284.108.18P	170
450	32	Aluminium	108	3,8	3,2	-6° Neg.	TCG	297.108.18P	171
450	30	Construction	32	3,8	2,8	15°	5° ATB	286.032.18M	161
450	30	Wood	36	3,8	2,8	20°	10° ATB	285.036.18M	161
450	30	Wood	66	3,8	2,8	10°	15° ATB	285.066.18M	162
450	60	Panel sizing	72	4,8	3,5	16°	TCG	282.072.18U	169
450	80	Panel sizing	72	4,8	3,5	16°	TCG	282.072.18W2	169
500	32	Aluminium	120	4	3,2	5° Pos.	TCG	284.120.20P	170
500	32	Aluminium	120	4	3,2	-6° Neg.	TCG	297.120.20P	171
500	30	Construction	36	3,8	2,8	15°	5° ATB	286.036.20M	161
500	30	Wood	72	3,8	2,8	10°	15° ATB	285.072.20M	162
500	60	Panel sizing	72	4,8	3,5	16°	TCG	282.072.20U	169
500	80	Panel sizing	72	4,8	3,5	16°	TCG	Y282.072.20W	169
550	30	Construction	40	4	3	15°	5° ATB	286.040.22M	161
550	100	Panel sizing	72	5,2	3,5	16°	TCG	282.072.22A	169
600	30	Construction	40	4	3	15°	5° ATB	286.040.24M	161



## Boring bits



Adaptors 192



Interchangeable boring bits 193



Boring bits 194



Plug cutters 198



Forstner bits 200



Brad point bits 202



Router bits for Domino® 205



Countersinks 207



Dovetail cutters 208

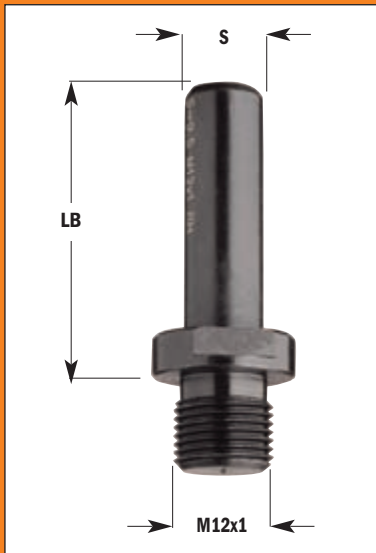

...with parallel shank for interchangeable bits

**509-532-533**

S Shank diameter mm	LB Adjusting length mm	ORDER NO. Right-hand rotation	ORDER NO. Left-hand rotation
8x30	35	<b>532.080.01</b>	
9,5x30	35	<b>532.095.01</b>	
10x50	60	<b>533.100.01</b>	<b>533.100.02</b>
12x30	35	<b>532.120.01</b>	
13x50	100	<b>509.130.01</b>	<b>509.130.02</b>
16x50	100	<b>509.160.01</b>	<b>509.160.02</b>

Used for assembly of the following parts: 501 HW

**TECHNICAL DETAILS:**

- Super strength steel
- Parallel shank with driving flat and adjustable screw length.

**APPLICATION:** used on boring machines with adaptor chucks.

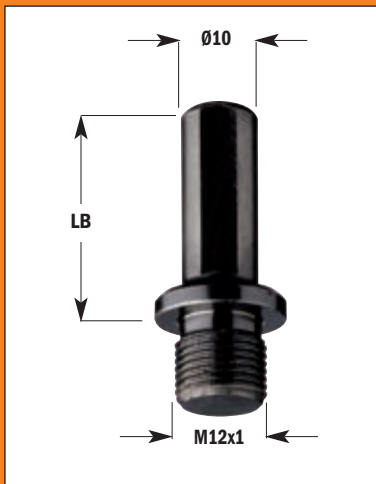

...with parallel shank for quick change drills

**511**

S Shank diameter mm	LB Adjusting length mm	ORDER NO. Right-hand rotation	ORDER NO. Left-hand rotation
10x20 (with driving flat & screws)	27	<b>511.270.01</b>	<b>511.270.02</b>
10x35 (with driving flat & screws)	40	<b>511.400.01</b>	<b>511.400.02</b>

Used for assembly of the following parts: 501 HW

**TECHNICAL DETAILS:**

- Super strength steel
- Parallel shank with driving flat and adjustable screw length.

**APPLICATION:** used on boring machines with adaptor chucks.



...with threaded shank for interchangeable bits

**506**

S Shank diameter	LB Adjusting length mm	ORDER NO. Right-hand rotation	ORDER NO. Left-hand rotation
M10/11x4	15	<b>506.150.01</b>	<b>506.150.02</b>
M10/11x4	25	<b>506.250.01</b>	<b>506.250.02</b>
M10/11x4	35	<b>506.350.01</b>	<b>506.350.02</b>

Used for assembly of the following parts: 501 HW

**TECHNICAL DETAILS:**

- Super strength steel
- Parallel shank with driving flat and adjustable screw length.

**APPLICATION:** used on boring machines with adaptor chucks.

...with threaded shank for interchangeable bits

**503**

S Shank diameter	LB Adjusting length mm	ORDER NO. Right-hand rotation	ORDER NO. Left-hand rotation
M10/30°	25	503.250.01	503.250.02
M10/30°	35	503.350.01	503.350.02
M10/30°	45	503.450.01	503.450.02

Used for assembly of the following parts: 501 HW

**TECHNICAL DETAILS:**

- Super strength steel
- Parallel shank with driving flat and adjustable screw length

**APPLICATION:** used on boring machines with adaptor chucks.



...with taper shank for interchangeable bits

**534**

S Shank diameter	ORDER NO. Right-hand rotation
MK2/Ø20x14Fx1"	534.020.01
MK2/M30x1,5	534.030.01

Used for assembly of the following parts: 501 HW

**TECHNICAL DETAILS:**

- Super strength steel

**APPLICATION:** used on CNC machines or hand-held routers equipped with adaptor chucks.

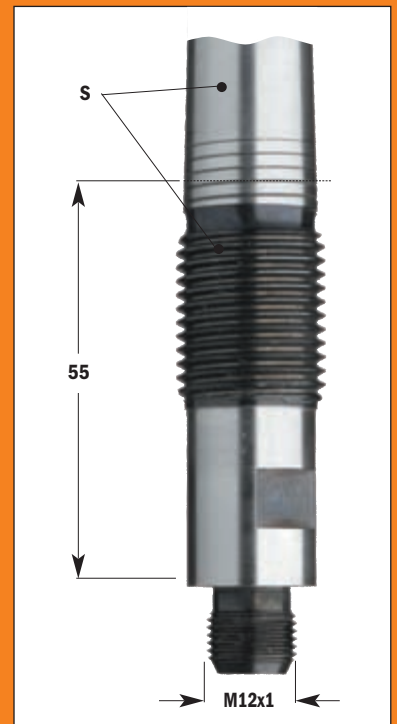

Interchangeable boring bits with threaded shank  
Shank M12x1

**501 HW**

D Cutting diameter mm	L Overall length mm	ORDER NO. Right-hand rotation	ORDER NO. Left-hand rotation
20	30	501.200.11	501.200.12
22	30	501.220.11	501.220.12
24	30	501.240.11	501.240.12
25	30	501.250.11	501.250.12
26	30	501.260.11	501.260.12
30	30	501.300.11	501.300.12
32	30	501.320.11	501.320.12
34	30	501.340.11	501.340.12
35	30	501.350.11	501.350.12
36	30	501.360.11	501.360.12
38	30	501.380.11	501.380.12
40	30	501.400.11	501.400.12
45	30	501.450.11	501.450.12
50	30	501.500.11	501.500.12
55	30	501.550.11	501.550.12
60	30	501.600.11	501.600.12

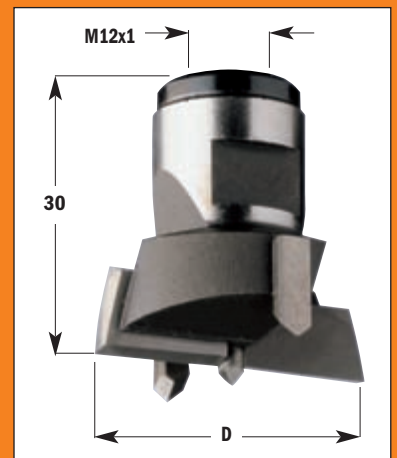



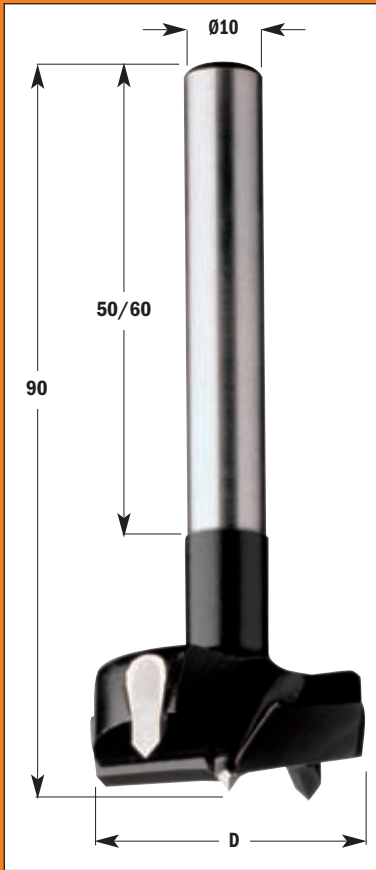

Shank Ø10x50/60mm

**512** HW

D Cutting diameter mm	L Overall length mm	ORDER NO. Right-hand rotation
14	90	512.140.11
15	90	512.150.11
16	90	512.160.11
<b>new</b> 17	90	512.170.11
18	90	512.180.11
<b>new</b> 19	90	512.190.11
20	90	512.200.11
<b>new</b> 21	90	512.210.11
22	90	512.220.11
23	90	512.230.11
24	90	512.240.11
25	90	512.250.11
26	90	512.260.11
<b>new</b> 27	90	512.270.11
28	90	512.280.11
<b>new</b> 29	90	512.290.11
30	90	512.300.11
<b>new</b> 31	90	512.310.11
32	90	512.320.11
<b>new</b> 33	90	512.330.11
34	90	512.340.11
35	90	512.350.11
38	90	512.380.11
40	90	512.400.11
45*	90	512.450.11
48*	90	512.480.11
50*	90	512.500.11
<b>new</b> 55*	90	512.550.11
<b>new</b> 58*	90	512.580.11
<b>new</b> 60*	90	512.600.11

\* Shank 10x50 mm

5 piece boring bit set for hinges

**512**



The perfect set for hinge work and other related applications. Machined from special high speed steel with micro-grain carbide tips, these bits are available in diameters of 15, 20, 25, 30 and 35mm.

Safely packaged in a solid plastic box with glass front for easy storage and inventory.

**TECHNICAL DETAILS:**

- Super strength steel
- HW precision balanced centre point
- 2 precision ground HW cutting edges (Z2)
- 2 HW negatively ground spurs

**APPLICATION:** used for drilling blind holes in solid wood, wood composites and plastic laminate materials. Ideal for hinges.

DESCRIPTION	ORDER NO. Right-hand rotation
...Shank Ø10mm - Overall length 90mm (Ø15-20-25-30-35mm)	<b>512.001.01</b>

Shank Ø10x30mm

**512 SP**

D Cutting diameter mm	L Overall length mm	ORDER NO. Right-hand rotation
8	90	512.081.31
10	90	512.101.31
12	90	512.121.31
15	90	512.151.31
16	90	512.161.31
18	90	512.181.31
20	90	512.201.31
22	90	512.221.31
24	90	512.241.31
25	90	512.251.31
26	90	512.261.31
28	90	512.281.31
30	90	512.301.31
32	90	512.321.31
35	90	512.351.31
38	90	512.381.31
40	90	512.401.31

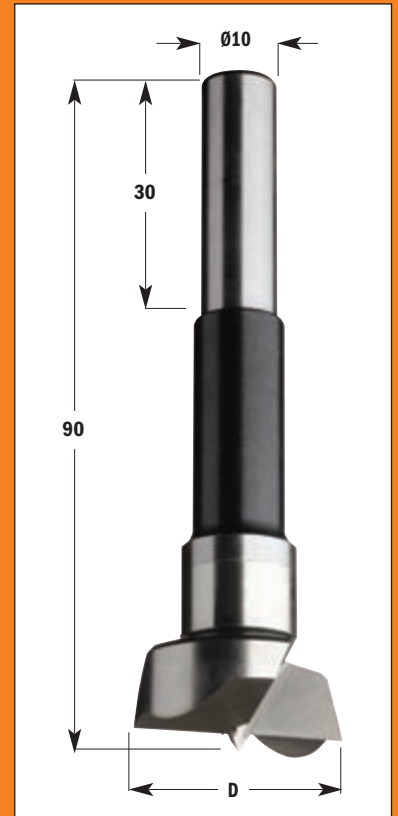

**5 piece boring bit set for hinges**

**512**



**SP**

The perfect set for hinge work and other related applications. Machined from special high speed steel these bits are available in diameters of 15, 20, 25, 30 and 35mm. Precision ground and sharpened with round shanks. Safely packaged in a solid plastic box with glass front for easy storage and inventory.

**TECHNICAL DETAILS:**

- SP steel
- Precision balanced centre point
- 2 spurs (V2)
- 2 precision ground cutting edges (Z2)
- Long lasting cutter performance

**APPLICATION:** used for drilling blind holes in softwood. Ideal for hinges.

DESCRIPTION	ORDER NO. Right-hand rotation
...Shank Ø10mm - Overall length 90mm (Ø15-20-25-30-35mm)	<b>512.001.00</b>



## 391 HW

D Cutting diameter mm	L Overall length mm	ORDER NO. Shank Ø 8mm	ORDER NO. Shank Ø 9,5mm	ORDER NO. Shank Ø 12,7mm
25	60	<b>391.250.11</b>		
26	60	<b>391.260.11</b>		
30	60	<b>391.300.11</b>		
35	60	<b>391.350.11</b>		
35	66		<b>391.352.11</b>	<b>391.351.11</b>

### TECHNICAL DETAILS:

- Super strength steel
- HW precision balanced centre point
- 2 precision ground HW cutting edges (Z2)
- Right-hand rotation (RH)

**APPLICATION:** used for drilling blind holes in solid wood, wood composites and plastic laminate materials. Ideal for hinges.

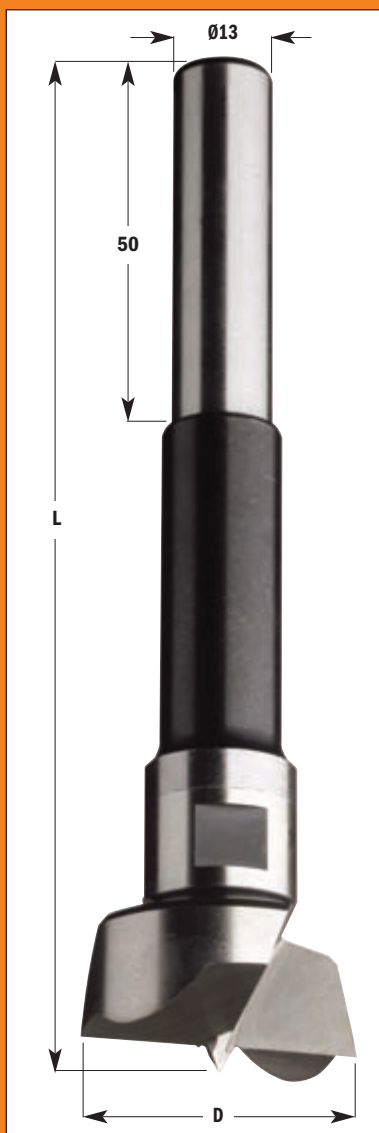

## 513 HL

D Cutting diameter mm	S Shank diameter mm	L Overall length mm	ORDER NO. Right-hand rotation
10	13	120	<b>513.100.31</b>
12	13	120	<b>513.120.31</b>
14	13	120	<b>513.140.31</b>
15	13	120	<b>513.150.31</b>
16	13	120	<b>513.160.31</b>
18	13	120	<b>513.180.31</b>
20	13	120	<b>513.200.31</b>
22	13	125	<b>513.220.31</b>
25	13	125	<b>513.250.31</b>
28	13	130	<b>513.280.31</b>
30	13	130	<b>513.300.31</b>
35	13	130	<b>513.350.31</b>
38	13	130	<b>513.380.31</b>

### TECHNICAL DETAILS:

- SP steel
- Precision balanced centre point
- 2 spurs (V2)
- 2 precision ground cutting edges (Z2)
- Long lasting cutter performance

**APPLICATION:** used for drilling blind holes in softwood. Ideal for hinges.

**513 HW**

D Cutting diameter mm	S Shank diameter mm	L Overall length mm	ORDER NO. Right-hand rotation
15	13	120	513.150.11
16	13	120	513.160.11
18	13	120	513.180.11
20	13	120	513.200.11
22	13	125	513.220.11
25	13	125	513.250.11
26	13	125	513.260.11
28	13	130	513.280.11
30	13	130	513.300.11
35	13	130	513.350.11
40	13	130	513.400.11
45	13	130	513.450.11
50	13	130	513.500.11
55	13	140	513.550.11
60	13	140	513.600.11

**TECHNICAL DETAILS:**

- Super strength steel
- HW precision balanced centre point
- 2 precision ground HW cutting edges (Z2)
- 2 HW negatively ground spurs

**APPLICATION:** used for drilling blind holes in solid wood, wood composites and plastic laminated materials. Ideal for hinges.

**514 HW**

D Cutting diameter mm	S Shank diameter mm	L Overall length mm	ORDER NO. Right-hand rotation
15	16	120	514.150.11
16	16	120	514.160.11
18	16	120	514.180.11
20	16	120	514.200.11
22	16	125	514.220.11
25	16	125	514.250.11
26	16	125	514.260.11
28	16	130	514.280.11
30	16	130	514.300.11
32	16	130	514.320.11
35	16	130	514.350.11
40	16	130	514.400.11
45	16	130	514.450.11
50	16	130	514.500.11
55	16	140	514.550.11
60	16	140	514.600.11

**TECHNICAL DETAILS:**

- Super strength steel
- HW precision balanced centre point
- 2 precision ground HW cutting edges (Z2)
- 2 HW negatively ground spurs

**APPLICATION:** used for drilling blind holes in solid wood, wood composites and plastic laminated materials. Ideal for hinges.

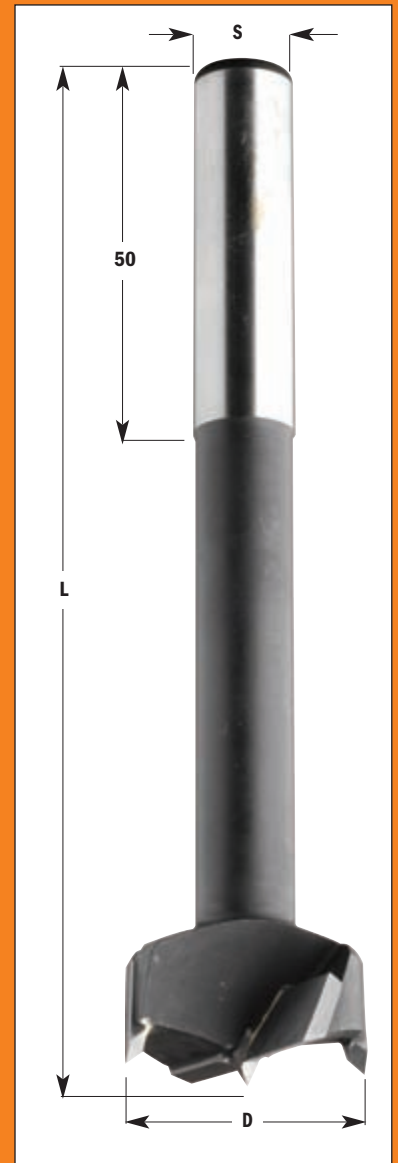





**529 SP**

d Small diameter mm	D Cutting diameter mm	S Shank diameter mm	L Overall length mm	Z Number of teeth	ORDER NO. Right-hand rotation
8	18	13	140	4	<b>529.080.31</b>
10	20	13	140	4	<b>529.100.31</b>
12	24	13	140	4	<b>529.120.31</b>
14	26	13	140	4	<b>529.140.31</b>
15	27	13	140	4	<b>529.150.31</b>
16	28	13	140	4	<b>529.160.31</b>
18	30	13	140	4	<b>529.180.31</b>
20	32	13	140	4	<b>529.200.31</b>
25	37	13	140	5	<b>529.250.31</b>
30	42	13	140	5	<b>529.300.31</b>
35*	47	16	160	6	<b>529.350.31</b>
40*	52	16	160	6	<b>529.400.31</b>

**529 SP**

d Small diameter mm	L Overall length inches	S Shank diameter inches	Z Number of teeth	ORDER NO. Right-hand rotation
3/8	5-1/2	1/2	4	<b>529.095.31</b>
1/2	5-1/2	1/2	4	<b>529.127.31</b>
5/8	5-1/2	1/2	4	<b>529.158.31</b>
3/4	5-1/2	1/2	4	<b>529.190.31</b>
7/8	5-1/2	1/2	4	<b>529.222.31</b>
1	5-1/2	1/2	5	<b>529.254.31</b>
1-1/4	6-5/16	5/8	5	<b>529.317.31</b>
1-3/8	6-5/16	5/8	6	<b>529.349.31</b>
1-5/8	6-5/16	5/8	6	<b>529.413.31</b>
1-3/4	6-5/16	5/8	6	<b>529.445.31</b>
2	6-5/16	5/8	6	<b>529.508.31</b>

Use our reduction bushing D=16mm to increase the 13mm shank (order no.799.130.00 page 111)

**TECHNICAL DETAILS:**

- SP steel
- Long lasting cutter performance

**APPLICATION:** used to make plugs in hard and soft woods.

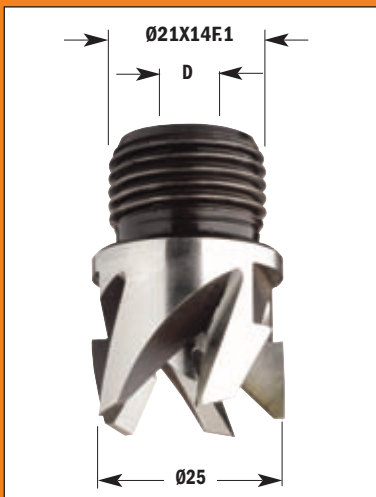

**Shank Ø21x14F.1"**

**530 HS**

D Cutting diameter mm	ORDER NO. Right-hand rotation
6,2	<b>530.062.51</b>
8	<b>530.080.51</b>
8,2	<b>530.082.51</b>
10	<b>530.100.51</b>
10,2	<b>530.102.51</b>
12	<b>530.120.51</b>
12,2	<b>530.122.51</b>

**TECHNICAL DETAILS:**

- Super strength HS steel
- 4 precision ground cutting edges (Z4)
- Long lasting cutter performance

**APPLICATION:** used for cutting dowels.

**REMARK:** available on request.

**500.001/02/03**



We offer a wide range of boring bits and plug cutters in the most popular diameters. If you need to bore or to make plugs in soft wood this is what you need!



**500.001.08 Boring bit & plug cutter set**

Set contains	D Cutting diameter mm	I Cutting length mm	S Shank diameter mm	ORDER NO. Right-hand rotation
Boring bit with parallel shank	8	90	10	<b>512.081.31</b>
Boring bit with parallel shank	10	90	10	<b>512.101.31</b>
Boring bit with parallel shank	12	90	10	<b>512.121.31</b>
Boring bit with parallel shank	15	90	10	<b>512.151.31</b>
Plug cutter	8	140	13	<b>529.080.31</b>
Plug cutter	10	140	13	<b>529.100.31</b>
Plug cutter	12	140	13	<b>529.120.31</b>
Plug cutter	15	140	13	<b>529.150.31</b>

**500.002.08 Boring bit & plug cutter set**

Set contains	D Cutting diameter mm	I Cutting length mm	S Shank diameter mm	ORDER NO. Right-hand rotation
Boring bit with parallel shank	16	90	10	<b>512.161.31</b>
Boring bit with parallel shank	20	90	10	<b>512.201.31</b>
Boring bit with parallel shank	25	90	10	<b>512.251.31</b>
Boring bit with parallel shank	30	90	10	<b>512.301.31</b>
Plug cutter	16	140	13	<b>529.160.31</b>
Plug cutter	20	140	13	<b>529.200.31</b>
Plug cutter	25	140	13	<b>529.250.31</b>
Plug cutter	30	140	13	<b>529.300.31</b>

**500.003.08 Boring bit & plug cutter set**

Set contains	D Cutting diameter mm	I Cutting length mm	S Shank diameter mm	ORDER NO. Right-hand rotation
Boring bit with parallel shank	15	90	10	<b>512.151.31</b>
Boring bit with parallel shank	20	90	10	<b>512.201.31</b>
Boring bit with parallel shank	25	90	10	<b>512.251.31</b>
Boring bit with parallel shank	30	90	10	<b>512.301.31</b>
Plug cutter	15	140	13	<b>529.150.31</b>
Plug cutter	20	140	13	<b>529.200.31</b>
Plug cutter	25	140	13	<b>529.250.31</b>
Plug cutter	30	140	13	<b>529.300.31</b>

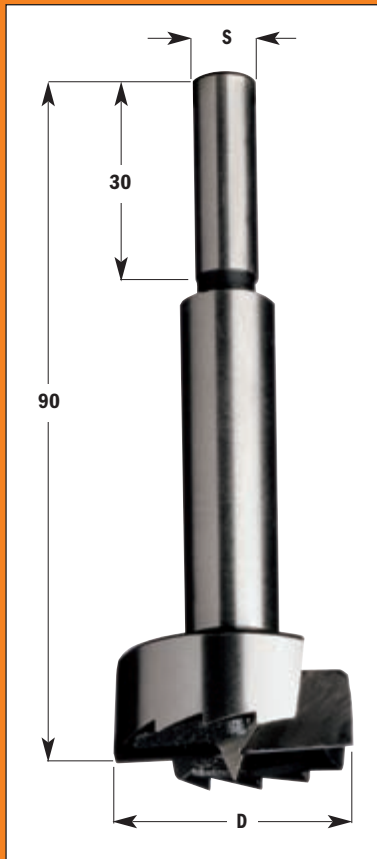

**537 SP**

D Cutting diameter mm	S Shank diameter mm	L Overall length mm	ORDER NO. Right-hand rotation
10	8	90	<b>537.100.31</b>
12	8	90	<b>537.120.31</b>
14	8	90	<b>537.140.31</b>
15	8	90	<b>537.150.31</b>
16	8	90	<b>537.160.31</b>
18	8	90	<b>537.180.31</b>
20	8	90	<b>537.200.31</b>
22	8	90	<b>537.220.31</b>
24	8	90	<b>537.240.31</b>
25	8	90	<b>537.250.31</b>
26	8	90	<b>537.260.31</b>
28	8	90	<b>537.280.31</b>
30	8	90	<b>537.300.31</b>
32	10	90	<b>537.320.31</b>
35	10	90	<b>537.350.31</b>
38	10	90	<b>537.380.31</b>
40	10	90	<b>537.400.31</b>
45	10	90	<b>537.450.31</b>
50	10	90	<b>537.500.31</b>
<small>new</small> 55	10	90	<b>537.550.31</b>
<small>new</small> 68	12,5	159	<b>537.680.31</b>

**537 SP**

D Cutting diameter inches	S Shank diameter inches	L Overall length mm	ORDER NO. Right-hand rotation
1/4	3/8	90	<b>537.064.31</b>
3/8	3/8	90	<b>537.095.31</b>
1/2	3/8	90	<b>537.127.31</b>
5/8	3/8	90	<b>537.158.31</b>
3/4	3/8	90	<b>537.190.31</b>
7/8	3/8	90	<b>537.222.31</b>
1	3/8	90	<b>537.254.31</b>
1-1/8	3/8	90	<b>537.285.31</b>
1-1/4	3/8	90	<b>537.317.31</b>
1-3/8	3/8	90	<b>537.349.31</b>
1-1/2	3/8	90	<b>537.381.31</b>
1-5/8	3/8	90	<b>537.413.31</b>
1-3/4	3/8	90	<b>537.445.31</b>
1-7/8	3/8	90	<b>537.476.31</b>
2	3/8	90	<b>537.508.31</b>
2-1/8	3/8	90	<b>537.540.31</b>

**TECHNICAL DETAILS:**

- Super strength SP steel
- Precision balanced centre point
- 2 spurs (V2)
- 2 precision ground cutting edges (Z2)
- Long lasting cutter performance

**APPLICATION:** used to drill precise flat bottom holes with no chipping in any thickness of soft wood.



We offer a wide range of Forstner Bits in the most popular diameters. These bits are available individually or in beautiful wooden sets. There is a high performance stagger tooth design on all larger diameter bits for clean sharp holes with straight sides and flat bottoms. These bits are ideal for drill presses, electric and cordless drills in all types of soft wood.



**537.000.05**

**537.000.16**



**537.000.12**



**537.000.07**



DESCRIPTION			ORDER NO. Right-hand rotation
5 pcs. router bit set	(S=8-10mm)	Ø15-20-25-30-35mm	<b>537.000.05</b>
12 pcs. router bit set	(S=8-10mm)	Ø10-12-14-15-16-18-20-22-25-26-30-35mm	<b>537.000.12</b>
7 pcs. router bit set	(S=3/8")	Ø1/4" - 3/8" - 1/2" - 5/8" - 3/4" - 7/8" - 1"	<b>537.000.07</b>
16 pcs. router bit set	(S=3/8")	Ø1/4" - 3/8" - 1/2" - 5/8" - 3/4" - 7/8" - 1" - 1-1/8" - 1-1/4"-1-3/8"-1-1/2"-1-5/8"-1-3/4"-1-7/8"-2"-2-1/8"	<b>537.000.16</b>



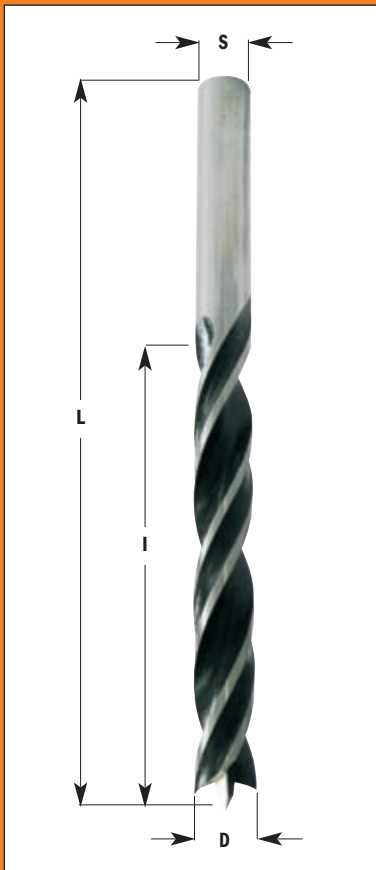

**517 HS**

D Cutting diameter mm	S Shank diameter mm	I Cutting length mm	L Overall length mm	ORDER NO. Right-hand rotation
3	3	33	61	<b>517.030.51</b>
4	4	43	75	<b>517.040.51</b>
5	5	52	86	<b>517.050.51</b>
6	6	53	92	<b>517.060.51</b>
7	7	69	109	<b>517.070.51</b>
8	8	75	117	<b>517.080.51</b>
9	9	80	123	<b>517.090.51</b>
10	10	84	133	<b>517.100.51</b>
11	10	89	142	<b>517.110.51</b>
12	10	93	151	<b>517.120.51</b>
13	10	93	151	<b>517.130.51</b>
14	10	93	151	<b>517.140.51</b>
15	10	93	151	<b>517.150.51</b>
16	10	93	151	<b>517.160.51</b>

**TECHNICAL DETAILS:**

- Super strength HS steel
- Precision balanced center point
- 2 precision ground cutting edges (Z2)
- 4 flutes

**APPLICATION:** used for drilling holes in hard and soft wood. **Long lasting cutter performance**

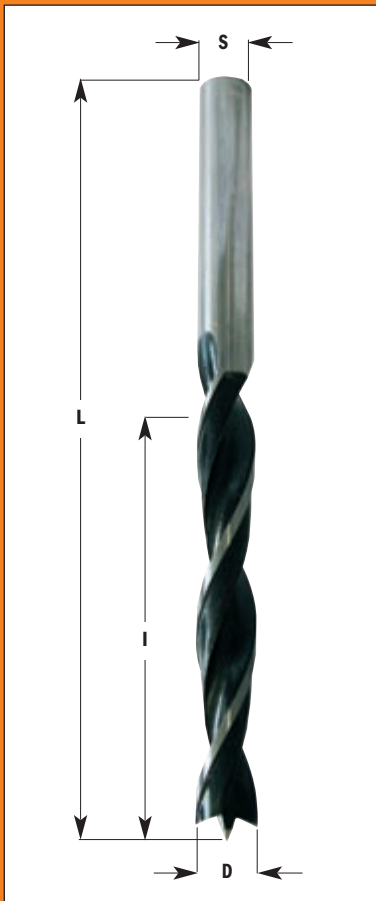

**517 SP**

D Cutting diameter mm	S Shank diameter mm	I Cutting length mm	L Overall length mm	ORDER NO. Right-hand rotation
3	3	33	61	<b>517.030.31</b>
4	4	43	75	<b>517.040.31</b>
5	5	52	86	<b>517.050.31</b>
6	6	57	94	<b>517.060.31</b>
7	7	69	109	<b>517.070.31</b>
8	8	75	117	<b>517.080.31</b>
9	9	80	125	<b>517.090.31</b>
10	10	87	133	<b>517.100.31</b>
11	10	89	142	<b>517.110.31</b>
12	10	96	151	<b>517.120.31</b>
13	10	96	151	<b>517.130.31</b>
14	10	97	151	<b>517.140.31</b>
15	10	100	160	<b>517.150.31</b>
16	10	100	160	<b>517.160.31</b>
18	10	120	180	<b>517.180.31</b>
20	13	130	200	<b>517.200.31</b>

**TECHNICAL DETAILS:**

- Super strength SP steel
- Precision balanced center point
- 2 precision ground cutting edges (Z2)
- 2 flutes

**APPLICATION:** used for drilling holes in soft wood.

**515 HS Z2**

ANUBA no.	d Small diam. mm	D-S Diam. shank mm	l <sub>1</sub> Cutting length mm	l <sub>2</sub> Cutting length mm	LB Adjust. length mm	L Overall length mm	ORDER NO. Rotazione destra
9,5	3,8	5,2	18	56	74	132	<b>515.095.51</b>
11	4,8	5,7	17	60	76	145	<b>515.110.51</b>
13	5,8	6,7	18	68	83	155	<b>515.130.51</b>
14,5	6,3	7,2	19	75	89	165	<b>515.145.51</b>
16	6,7	7,7	25	85	100	165	<b>515.160.51</b>
18	7,7	8,7	25	85	102	165	<b>515.180.51</b>
20	8,8	9,8	25	90	104	165	<b>515.200.51</b>



**TECHNICAL DETAILS:**

- Super strength steel
- HS steel
- 2 precision ground cutting edges HS (Z2)
- 2 spiral flutes

**APPLICATION:** used for drilling blind holes in hard and soft wood for ANUBA hinges applications.

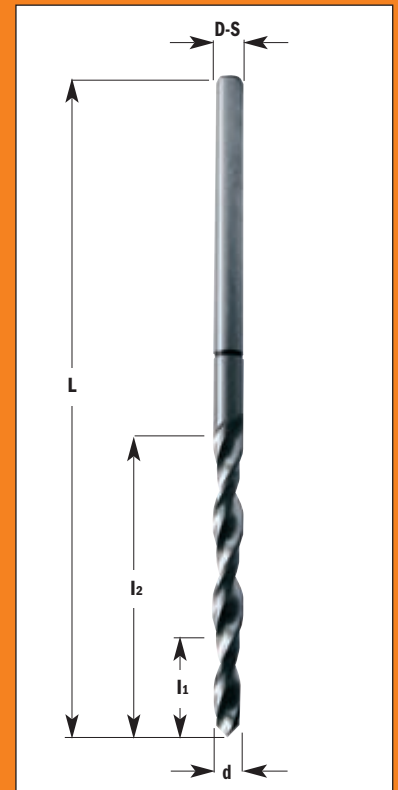

**Brad point bit sets**



**5 piece brad point bit set**

An economical collection of the five most popular sized Brad Points - 4, 5, 6, 8 and 10. Safely packaged in a reusable plastic case for easy storage and inventory.

**8 piece brad point bit set**

A complete collection of the most popular Brad Points in the most requested sizes - 3, 4, 5, 6, 7, 8, 9 and 10. Safely packaged in a reusable plastic case for easy storage and inventory.



**517**

DESCRIPTION	ORDER NO. Right-hand rotation
5 pcs. brad point set HS, 4 flutes (Ø4-5-6-8-10mm)	<b>517.001.01</b>
5 pcs. brad point set SP, 2 flutes (Ø4-5-6-8-10mm)	<b>517.001.00</b>
8 pcs. brad point set HS, 4 flutes (Ø3-4-5-6-7-8-9-10mm)	<b>517.002.01</b>
8 pcs. brad point set SP, 2 flutes (Ø3-4-5-6-7-8-9-10mm)	<b>517.002.00</b>

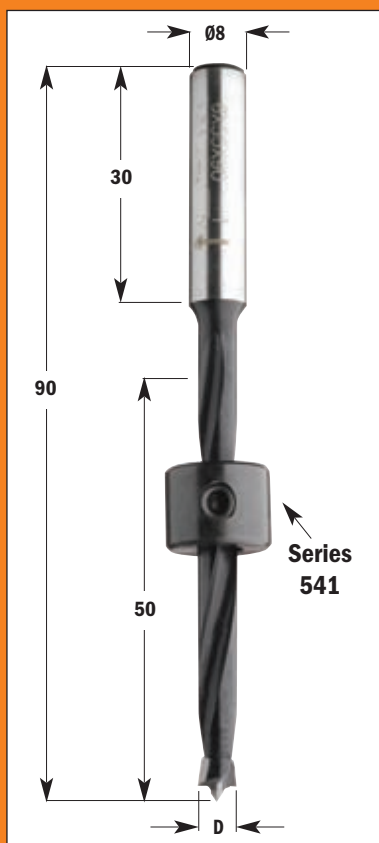
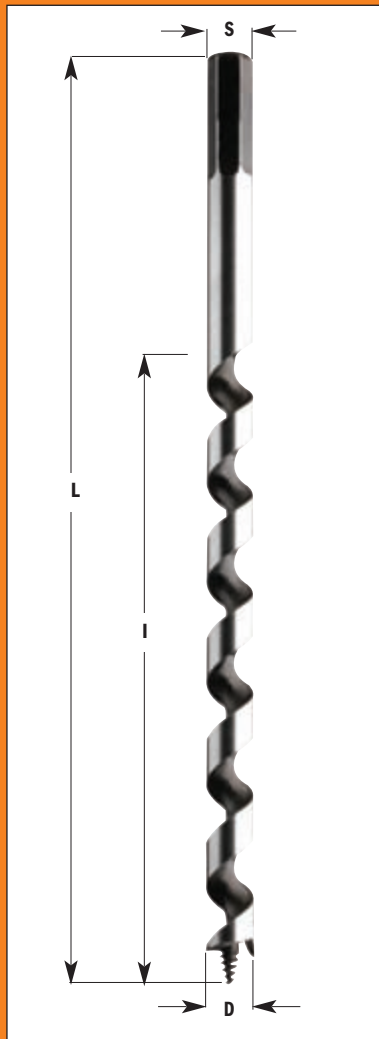

**542 HS**

D Cutting diameter mm	S Shank diameter	I Cutting length mm	L Overall length mm	ORDER NO. Right-hand rotation
6	exagonal	155	230	<b>542.060.51</b>
8	exagonal	155	230	<b>542.080.51</b>
10	exagonal	155	230	<b>542.100.51</b>
12	exagonal	155	230	<b>542.120.51</b>
14	exagonal	155	230	<b>542.140.51</b>
16	exagonal	155	230	<b>542.160.51</b>
18	exagonal	155	230	<b>542.180.51</b>
20	exagonal	155	230	<b>542.200.51</b>

**535 HS**

D Cutting diameter mm	S Shank diameter	I Cutting length mm	L Overall length mm	ORDER NO. Right-hand rotation
8	exagonal	360	460	<b>535.080.51</b>
10	exagonal	360	460	<b>535.100.51</b>
12	exagonal	360	460	<b>535.120.51</b>
14	exagonal	360	460	<b>535.140.51</b>
16	exagonal	360	460	<b>535.160.51</b>
18	exagonal	360	460	<b>535.180.51</b>
20	exagonal	360	460	<b>535.200.51</b>

**TECHNICAL DETAILS:**

- Super strength HS steel
- Precision balanced centre point
- 1 precision ground cutting edges (Z1)
- 1 spiral flutes - 1 spurs (V1)
- Long lasting cutter performance

**APPLICATION:** used for drilling deep holes in hard and soft wood.

**540 HW**

**Shank Ø8x30mm**

D Cutting diameter mm	L Overall length mm	ORDER NO. Right-hand rotation
5	90	<b>540.050.11</b>
6	90	<b>540.060.11</b>
8	90	<b>540.080.11</b>
10	90	<b>540.100.11</b>
12	90	<b>540.120.11</b>

**TECHNICAL DETAILS:**

- Super strength steel - HW head with precision balanced centre point
- 2 precision ground cutting edges (Z2) - 2 spiral flutes

**APPLICATION:** used for drilling blind holes in solid wood, wood composites or plastic laminates. Usable on hand-held routers.

**Stop collar**

**541**

D <sub>3</sub> Per punta diametro mm	ORDER NO.
5	<b>541.050.00</b>
6	<b>541.060.00</b>
8	<b>541.080.00</b>
10	<b>541.100.00</b>
12	<b>541.120.00</b>

Stop collar with precision clamping nut and key for quick and easy assembly.

**312 HW**

D Cutting diameter mm	I Cutting length mm	L Overall length mm	ORDER NO. Right-hand rotation
5	30	58	<b>312.050.11</b>
6	30	58	<b>312.060.11</b>
8	30	58	<b>312.080.11</b>
10	30	58	<b>312.100.11</b>
12	30	58	<b>312.120.11</b>
14	30	58	<b>312.140.11</b>
16	30	58	<b>312.160.11</b>

These drill bits are made with high-strength steel in order to work with high speed rotation. They are perfect to bore all materials like solid wood, wood and composites, plastic and laminated with **hand or cnc router and MAFELL® machine model DD40**.

**TECHNICAL DETAILS:**

- Super strength steel
- Spiral portion coated with black P.T.F.E.
- HW precision balanced centre point
- 2 precision ground HW cutting edges (Z2)
- 2 spiral flutes
- Parallel shank with driving flat and length adjusting screw.

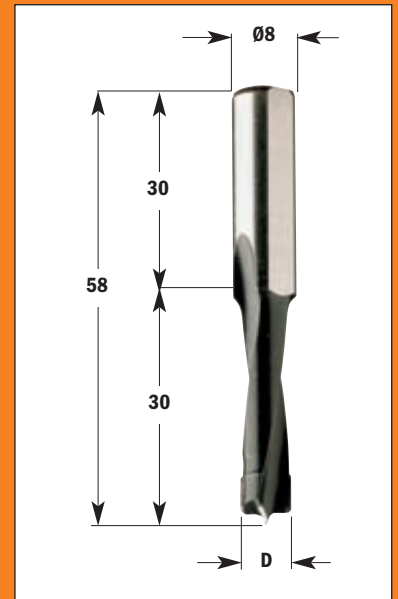

**Router bits for Domino® Joining machine by Festool®**

**380 HW**

D Cutting diameter mm	I Cutting length mm	L Overall length mm	S Shank diameter mm	ORDER NO. Right-hand rotation
5	20	49	M6x0,75	<b>380.050.11</b>
6	28	49	M6x0,75	<b>380.060.11</b>
8	28	49	M6x0,75	<b>380.080.11</b>
10	28	49	M6x0,75	<b>380.100.11</b>

**TECHNICAL DETAILS:**

- Premium quality super-strength steel
- Spiral portion coating with black P.T.F.E.
- Extra-fine micrograin carbide spiral portion
- 2 cutting edges [Z2]
- 2 spiral flutes

**APPLICATION:** used on "Domino®" machines for routing slots on solid wood and wood composites.

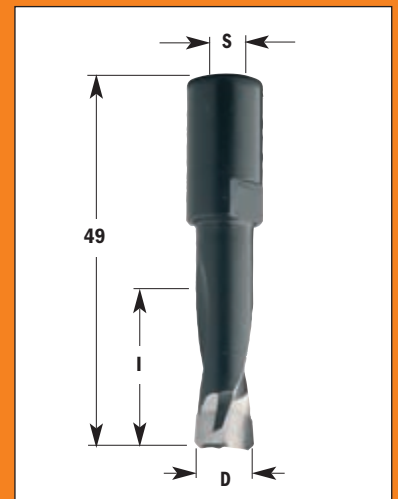



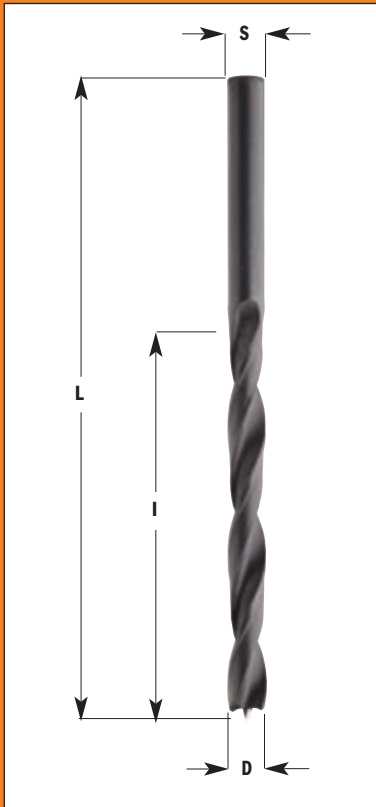

**Shank=Diameter**

**516 HS**

D Cutting diameter mm	I Cutting length mm	L Overall length mm	ORDER NO.	
			Right-hand rotation	Left-hand rotation
2	24	49	<b>516.020.51</b>	<b>516.020.52</b>
2,5	30	57	<b>516.025.51</b>	<b>516.025.52</b>
3	33	61	<b>516.030.51</b>	<b>516.030.52</b>
3,5	39	70	<b>516.035.51</b>	<b>516.035.52</b>
4	43	75	<b>516.040.51</b>	<b>516.040.52</b>
4,5	47	80	<b>516.045.51</b>	<b>516.045.52</b>
5	52	86	<b>516.050.51</b>	<b>516.050.52</b>
5,5	57	93	<b>516.055.51</b>	<b>516.055.52</b>
6	57	93	<b>516.060.51</b>	<b>516.060.52</b>
7	69	109	<b>516.070.51</b>	<b>516.070.52</b>
8	75	117	<b>516.080.51</b>	<b>516.080.52</b>
9	81	125	<b>516.090.51</b>	<b>516.090.52</b>
10	87	133	<b>516.100.51</b>	<b>516.100.52</b>

**TECHNICAL DETAILS:**

- Super strength steel
- Precision balanced centre point
- 2 precision ground cutting edges (Z2)
- 2 spiral flutes
- Common shank and cutting diameter (S=D)

**APPLICATION:** used for drilling blind holes in hard and soft wood.



**Adjustable countersink**

**521.001 HW**

D Cutting diameter mm	d Small diameter mm	ORDER NO. Right-hand rotation
da 11 a 15	da 3 a 7	<b>521.001.11</b>

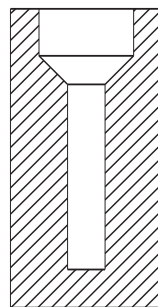

Twist drills	Overall diameter
Ø3	Ø11
Ø4	Ø12
Ø5	Ø13
Ø6	Ø14
Ø7	Ø15

**TECHNICAL DETAILS:**

- Premium quality HW
- 2 precision ground HW cutting edges (Z2)
- Quick and easy drill change

**APPLICATION:** used with spiral bits with parallel shanks.

**Twist drills not included.**

**Shank Ø10x30mm**

**521 HW**

D <sub>3</sub> For bit diameter mm	ORDER NO.	
	Right-hand rotation	Left-hand rotation
3	521.030.11	521.030.12
4	521.040.11	521.040.12
5	521.050.11	521.050.12
6	521.060.11	521.060.12

**TECHNICAL DETAILS:**

- Premium quality HW
- 2 precision ground HW cutting edges (Z2)
- Quick and easy drill change

**APPLICATION:** used with spiral bits with parallel shanks.

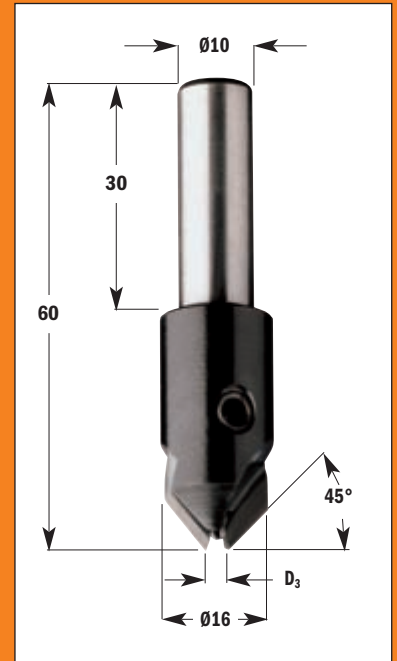

**Shank M10/Ø11x4mm**

**350 HW**

D <sub>3</sub> For bit diameter mm	ORDER NO.	
	Right-hand rotation	Left-hand rotation
3	350.030.11	350.030.12
4	350.040.11	350.040.12
5	350.050.11	350.050.12

**TECHNICAL DETAILS:**

- Premium quality HW
- 2 precision ground HW cutting edges (Z2)
- Quick and easy drill change

**APPLICATION:** used with spiral bits with parallel shanks.

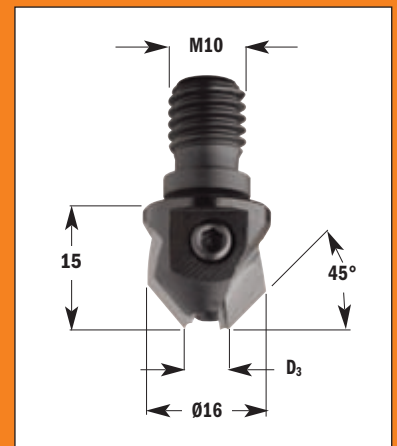

**Shank M10/30°**

**351 HW**

D <sub>3</sub> For bit diameter mm	ORDER NO.	
	Right-hand rotation	Left-hand rotation
3	351.030.11	351.030.12
4	351.040.11	351.040.12
5	351.050.11	351.050.12

**TECHNICAL DETAILS:**

- Premium quality HW
- 2 precision ground HW cutting edges (Z2)
- Quick and easy drill change

**APPLICATION:** used with spiral bits with parallel shanks.



**543** SP

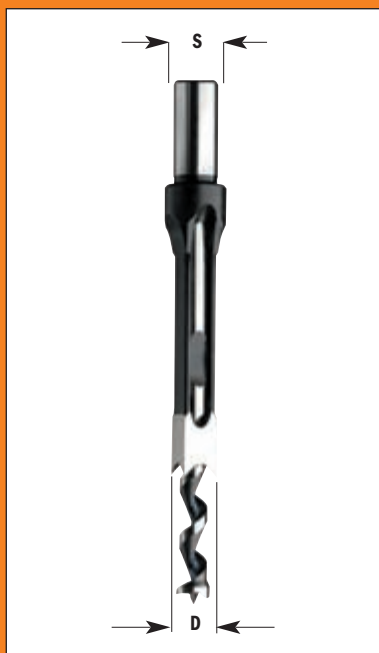

D Cutting diameter		Shank diameter		ORDER NO.
mm	inches	mm	inches	Right-hand rotation
6,35	1/4	19	3/4	<b>543.064.51</b>
8	5/16	19	3/4	<b>543.079.51</b>
9,5	3/8	19	3/4	<b>543.095.51</b>
12,7	1/2	19	3/4	<b>543.127.51</b>
15,8	5/8	19	3/4	<b>543.158.51</b>
19	3/4	19	3/4	<b>543.190.51</b>

It's tough to beat the "old faithful" mortise and tenon joint for strength and accuracy, even with all the other joining options in the world of woodworking. It isn't the easiest joint to make, but it sure helps to have the best quality tools in your shop. That's why we've added a new selection of Chisel and Bit sets in all the popular sizes, from 1/4" to 3/4" diameter.

These sets are for use in any standard drill press mortising attachment of mortising machine.

**9° Dovetail cutters**

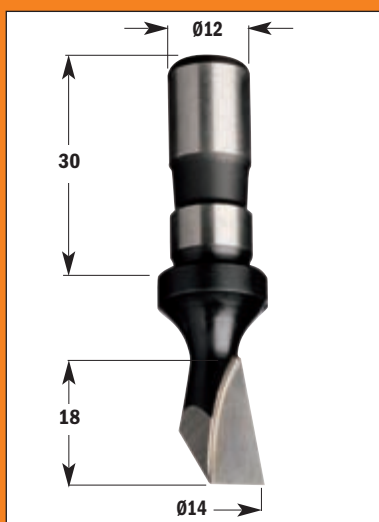

**Shank Ø12x30mm**

**522** HW

D Cutting diameter	I Cutting length	ORDER NO.
mm	mm	Right-hand rotation
14	18	<b>522.140.11</b>

**TECHNICAL DETAILS:**

- Super strength steel
- 1 HW precision ground cutting edge (Z1)



**Shank Ø10x40mm**

**523** HW

D Cutting diameter	I Cutting length	ORDER NO.
mm	mm	Right-hand rotation
14	16	<b>523.140.11</b>

**TECHNICAL DETAILS:**

- Super strength steel
- 2 HW precision ground cutting edges (Z2)



# Router cutters & Chucks

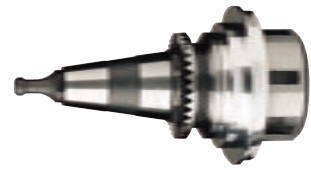

Chucks with precision collets **211**



Precision collets **214**



Solid carbide spiral bits Z3R **220**



Spoilboard surfacing router cutters **225**



DP router cutter with shearr angle **227**



Router cutters **232**



Grooving cutters **235**



Slot and mortise boring bits **236**



Slot mortising bits **238**



**The ideal accessory for machining centres, point-to-point machines and CNC Routers**

In a high-speed, fully-automated production environment, it is important to use chucks which offer high precision and total reliability. As one of Europe's leading manufacturers of cutting tools, CMT has produced chucks designed to withstand everyday professional use.

Machined from special super-strength steel, CMT chucks easily meet the demands of production routing and all other router applications.

CMT chucks offer these special features:

- Defect-free rotation
- Precision jointed parts
- Sturdy design with reduced height to increase the work space between the machine and the piece
- Replaceable precision collects STD "ER 32" (∅ from 3 to 20mm) and STD "ER40" (∅ from 4 to 25mm)
- Wide clamping tolerance (± 0.7mm)
- Right hand and left hand thread options
- Clamping nut with radial grooves (Woodruff) for C-spanner
- Cap nut with threaded spindle nose
- Designed and tested by leading manufacturers of machining centres and CNC routers.

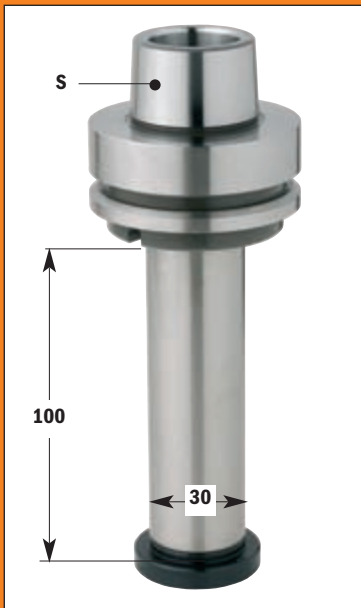

**Cutter arbor with HSK tapered shank**

For Homag, Eima from 9/94, Dubus, Weeke, Biesse, SCM, Morbidelli and Masterwood machines

**183.360**

S Shank diameter	Arbor			ORDER NO.
HSK-F63	∅30x100			183.360.00

**Cutter arbor with ISO30 tapered shank**

For Biesse machines

**183.260**

S Shank diameter	Arbor			ORDER NO.
ISO 30	∅30x100			183.260.00

REMARK: special dimensions available on request



**HSK Chuck with precision collet "ER32"**

For Homag, Eima from 9/94, Dubus, Weeke, Biesse, SCM, Morbidelli and Masterwood machines

**183.300**

S Shank diameter	To be used with collet		ORDER NO. Right-hand rotation	ORDER NO. Left-hand rotation
HSK-F63	ER32		183.300.01	183.300.02

For Biesse machines

**183.200**

S Shank diameter	To be used with collet	ORDER NO. Right-hand rotation	ORDER NO. Left-hand rotation
ISO 30	ER32	<b>183.200.01</b>	<b>183.200.02</b>

For Biesse machines with Omlat engine,  
Bulleri, Busellato, CMS and IMA machines

**183.210**

S Shank diameter	To be used with collet	ORDER NO. Right-hand rotation	ORDER NO. Left-hand rotation
ISO 30	ER32	<b>183.210.01</b>	<b>183.210.02</b>

For Alberti and Masterwood machines

**183.220**

S Shank diameter	To be used with collet	ORDER NO. Right-hand rotation	ORDER NO. Left-hand rotation
ISO 30	ER32	<b>183.220.01</b>	<b>183.220.02</b>

Retaining stud for ISO30 chucks

DESCRIPTION	ORDER NO.
Retaining stud Ø12/8 for chuck 183.200	<b>995.200.00</b>
Retaining stud Ø13/9 for chuck 1183.210	<b>995.201.00</b>
Retaining stud Ø12,8/9 for chuck 1183.220	<b>995.202.00</b>

For Morbidelli and SCM machines

**183.250**

S Shank diameter	To be used with collet	ORDER NO. Right-hand rotation	ORDER NO. Left-hand rotation
ISO 30	ER32	<b>183.250.01</b>	<b>183.250.02</b>

For Morbidelli and SCM machines aluminium flange  
already assembled Ø69,5mm

**183.251**

S Shank diameter	To be used with collet	ORDER NO. Right-hand rotation	ORDER NO. Left-hand rotation
ISO 30	ER32	<b>183.251.01</b>	<b>183.251.02</b>

Retaining stud and aluminium flange

DESCRIPTION	ORDER NO.
Retaining stud Ø8,5mm	<b>995.250.00</b>
Aluminium flange Ø69,5mm	<b>992.501.00</b>

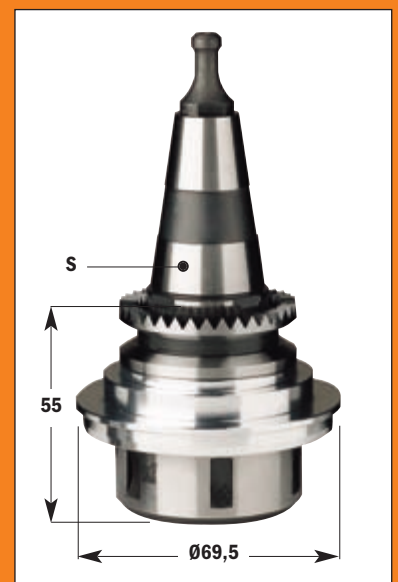

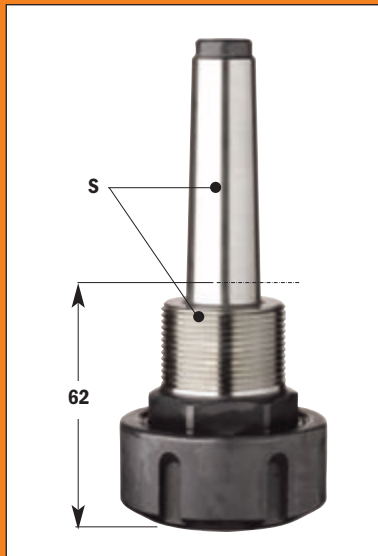

**MK2/MK3 tapered shank**

**183.000/100**

S Shank diameter	To be used with collet	ORDER NO.	
		Right-hand rotation	Left-hand rotation
MK2/M30x1,5mm	ER32	<b>183.000.01</b>	<b>183.000.02</b>
MK3/M30x1,5mm	ER32	<b>183.100.01</b>	

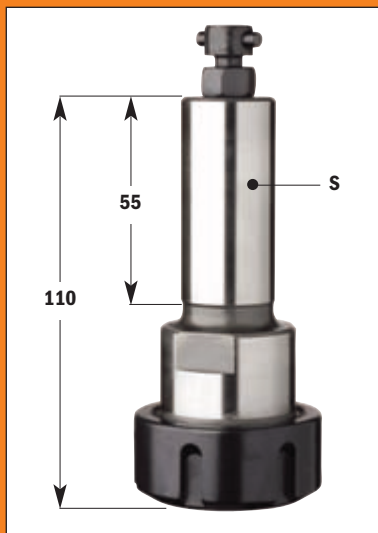

**...parallel shank Ø25mm**

**For machines with PS Leuco system**

**183.400**

S Shank diameter	To be used with collet	ORDER NO.	
		Right-hand rotation	Left-hand rotation
Ø25x55mm	ER32	<b>183.400.01</b>	

**Retaining stud**

DESCRIPTION	ORDER NO.
Retaining stud for PS Leuco System	<b>995.400.00</b>



**Cap nuts for chuck with collet "ER32"**

**992.183**

DESCRIPTION	ORDER NO.	
	Right-hand rotation	Left-hand rotation
Clamping nut for 183.000/100/200/250/300/400	<b>992.183.01</b>	<b>992.183.02</b>
<b>Clamping nut with bearing</b>		
Clamping nut for 183.000/100/200/250/300/400	<b>992.183.11</b>	<b>992.183.12</b>



**C-Spanner**

**991.183**

DESCRIPTION	ORDER NO.
C-Spanner type "Usag"52-55	<b>991.183.00</b>

Cap nuts for to point machines

**993.0**

Internal thread	ORDER NO. Right-hand rotation	ORDER NO. Left-hand rotation
Ø20x14Fx1"	<b>993.020.01</b>	<b>993.020.02</b>
M30x1,5	<b>993.030.01</b>	<b>993.030.02</b>

For machines with M33x3 threaded spindle nose

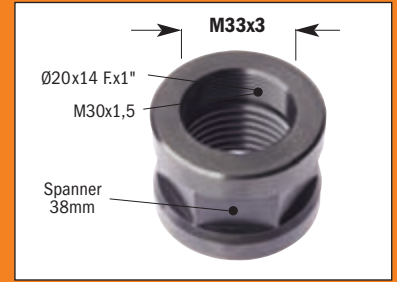

Cap nuts for routers

**993.5**

Internal thread	ORDER NO. Right-hand rotation	ORDER NO. Left-hand rotation
Ø20x14Fx1"	<b>993.520.01</b>	<b>993.530.01</b>
M30x1,5	<b>993.530.01</b>	<b>993.530.02</b>

For machines with 1-1/8"x7 threaded spindle nose



ISO30 Chuck with precision collet "ER40"

For Biesse machines

**183.201**

S Shank diameter	To be used with collet	ORDER NO. Right-hand rotation
ISO30	ER40	<b>183.201.01</b>

For Biesse machines with Omlat engine and Bulleri, Busellato, CMS and IMA machines

**183.211**

S Shank diameter	To be used with collet	ORDER NO. Right-hand rotation
ISO30	ER40	<b>183.211.01</b>

For Alberti & Masterwood machines

**183.221**

S Shank diameter	To be used with collet	ORDER NO. Right-hand rotation
ISO30	ER40	<b>183.221.01</b>

Retaining stud ISO30

DESCRIPTION	ORDER NO.
Retaining stud Ø12/8 for chuck 183.201	<b>995.200.00</b>
Retaining stud Ø13/9 for chuck 183.211	<b>995.201.00</b>
Retaining stud Ø12,8/9 for chuck 183.221	<b>995.202.00</b>





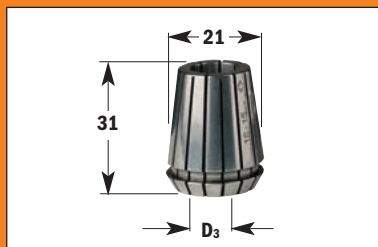

For Homag, Eima, IMA from 9/94, Dubus, Weeke, Biese, SCM, Morbidelli and Masterwood machines

**183.310**

S Shank diameter	To be used with collet	ORDER NO. Right-hand rotation	ORDER NO. Left-hand rotation
HSK-F63	ER40	<b>183.310.01</b>	<b>183.310.02</b>

Clamping nut for chucks with collet "ER40"

**992.383**

DESCRIPTION	ORDER NO. Right-hand rotation	ORDER NO. Left-hand rotation
Clamping nut for 183.201/211/221/310	<b>992.383.01</b>	<b>992.383.02</b>
<b>Clamping nut with bearing</b>		
Clamping nut with bearing for 183.201/211/221/310	<b>992.383.11</b>	

C-Spanner

**991.283**

DESCRIPTION	ORDER NO.
C-Spanner type "Usag" 58-62-65	<b>991.283.00</b>

Precision collet "ER20"

**184.xxx.20**

D <sub>3</sub> For bit diameter	ORDER NO.
mm	inches
3	<b>184.030.20</b>
6	<b>184.060.20</b>
6,35	1/4
8	5/16
10	3/8
12	<b>184.120.20</b>
12,7	1/2
	<b>184.127.20</b>

**TECHNICAL DETAILS:**

- Replaceable collets Std "ER20" (from 2 to 12,7mm)
- Fits most tapered spindle noses
- Wide clamping tolerance ± 0,7mm.

**REMARK:** special dimensions available on request

**Precision collet "ER25"**

**184.xxx.25**

D <sub>3</sub> For bit diameter		ORDER NO.
mm	inches	
6		184.060.25
8	5/16	184.080.25
10	3/8	184.100.25
12		184.120.25
14		184.140.25
16	5/8	184.160.25

**TECHNICAL DETAILS:**

- Replaceable collets Std "ER40" (from 2 to 16mm)
- Fits most tapered spindle noses - Wide clamping tolerance ± 0,7mm.

**Precision collet "ER32" for 183.000/100/200/250/300/400**

**184.000**

D <sub>3</sub> For bit diameter		ORDER NO.
mm	inches	
3		184.030.00
4		184.040.00
5		184.050.00
6		184.060.00
6,35	1/4	184.065.00
7		184.070.00
8	5/16	184.080.00
10	3/8	184.100.00
12		184.120.00
13	1/2	184.130.00
14		184.140.00
16	5/8	184.160.00
18		184.180.00
19	3/4	184.190.00
20		184.200.00

**TECHNICAL DETAILS:**

- Replaceable collets Std "ER40" (from 3 to 20mm)
- Fits most tapered spindle noses - Wide clamping tolerance ± 0,7mm.

**Precision collet "ER40" for 183.201/211/221/310**

**184.002**

D <sub>3</sub> For bit diameter		ORDER NO.
mm	inches	
4		184.042.00
5		184.052.00
6		184.062.00
7		184.072.00
8	5/16	184.082.00
10	3/8	184.102.00
12		184.122.00
13	1/2	184.132.00
14		184.142.00
16	5/8	184.162.00
18		184.182.00
19	3/4	184.192.00
20		184.202.00
25		184.252.00

**TECHNICAL DETAILS:**

- Replaceable collets Std "ER40" (from 4 to 25mm)
- Fits most tapered spindle noses - Wide clamping tolerance ± 0,7mm.

**REMARK:** special dimensions available on request

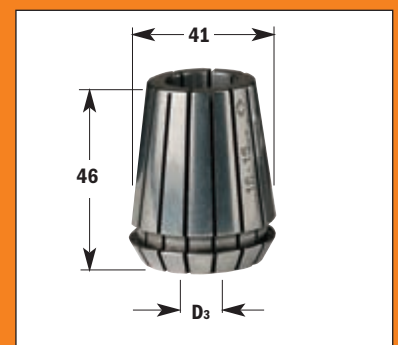
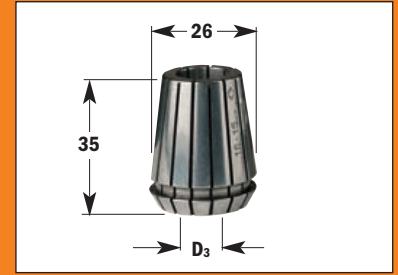



For Morbidelli/SCM machines

**183.255**

S Shank diameter	To be used with collet	ORDER NO. Right-hand rotation
ISO30	DIN6388	<b>183.255.01</b>

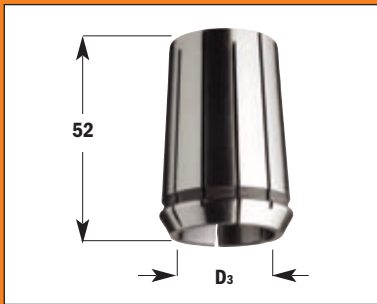

Precision collet Ø25mm DIN 6388 for 183.255

**185**

D <sub>3</sub> For bit diameter mm	ORDER NO.
25	<b>185.250.00</b>

REMARK: special dimensions available on request



Clamping nut

**992.283**

DESCRIPTION	ORDER NO. Right-hand rotation
Clamping nut for 183.255	<b>992.283.01</b>



C-Spanner

**991.283**

DESCRIPTION	ORDER NO.
C-Spanner type "Usag" 58-62-65	<b>991.283.00</b>

**123**

S Shank diameter	ORDER NO.	
	Right-hand rotation	Left-hand rotation
MK2/Ø20x14Fx1"	<b>123.000.01</b>	<b>123.000.02</b>

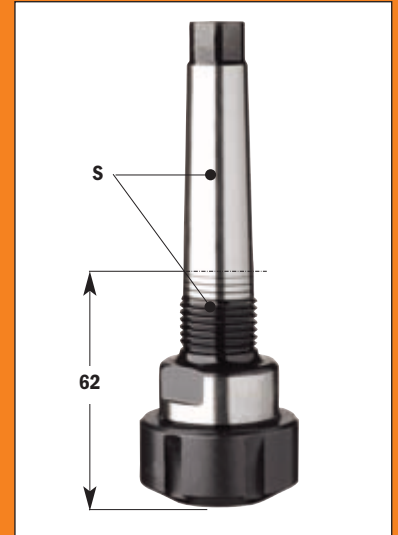

**Collet for 123**

**124**

D <sub>3</sub> For bit diameter	ORDER NO.	
	mm	inches
6		<b>124.060.00</b>
6,35	1/4	<b>124.064.00</b>
8	5/16	<b>124.080.00</b>
9,52	3/8	<b>124.095.00</b>
10		<b>124.100.00</b>
12		<b>124.120.00</b>
12,7	1/2	<b>124.127.00</b>
14		<b>124.140.00</b>

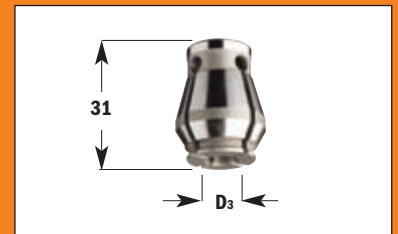

**Clamping nut**

**992.123**

DESCRIPTION	ORDER NO.	
	Right-hand rotation	Left-hand rotation
Clamping nut	<b>992.123.01</b>	<b>992.123.02</b>



**C-Spanner**

**991.123**

DESCRIPTION	ORDER NO.
C-Spanner "Usag" 40-42	<b>991.123.00</b>





## Sharp technology With a new twist

A special super-micrograin carbide formulation was created to produce and hold a keen cutting edge.

The new low-angle spiral is designed specifically to shear wood cleanly and provide efficient chip ejection. The tools run cooler and the edge lasts longer.

Increased feed rates while improving cut quality, means increased productivity with CMT.

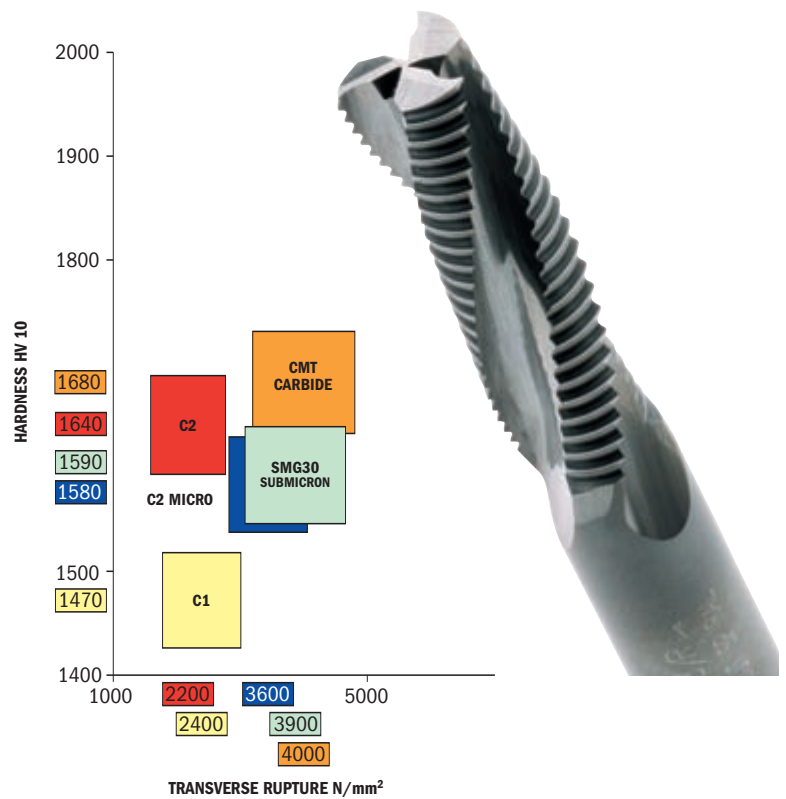
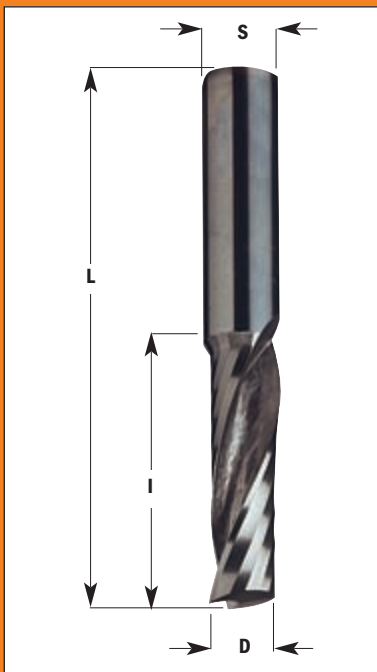

### ...up cut

### 198 HWM Z1

S=D Cutting diameter		I Cutting length	L Overall length	ORDER NO.
mm	inches	mm	mm	Right-hand rotation
3		12	50	<b>198.030.11</b>
3,18	1/8	12,7	50,8	<b>198.001.11</b>
4		15	50	<b>198.040.11</b>
4,76	3/16	15,87	50,8	<b>198.005.11</b>
5		17	50	<b>198.050.11</b>
6		22	60	<b>198.060.11</b>
6,35	1/4	19,05	50,8	<b>198.007.11</b>
6,35	1/4	25,4	63,5	<b>198.008.11</b>
8		22	70	<b>198.080.11</b>
9,52	3/8	28,57	76,2	<b>198.504.11</b>
10		32	70	<b>198.100.11</b>
12		32	80	<b>198.120.11</b>

#### TECHNICAL DETAILS:

- Premium quality HWM
- 1 up cut spiral cutting edge HW [Z1]
- Provides an excellent finish on the lower side of the work piece
- Upward chip ejection

**APPLICATION:** used for cutting, copying, panel sizing and any routing applications in solid wood, wood composites, plastic materials and laminates. Use a high feed speed on well-clamped workpieces. Can be used on machining centres, point to point machines, CNC routers and hand-held routers equipped with chucks or adaptors.

...up & down cut

**190** HWM Z2+2

S=D Cutting diameter		I Cutting length	I <sub>2</sub> Cutting length pos.	L Overall length	ORDER NO. Right-hand rotation
mm	inches	mm	mm	mm	
8		32	7	80	<b>190.080.11</b>
9,53	3/8	28,6	7	76,2	<b>190.504.11</b>
10		32	7	80	<b>190.100.11</b>
12		42	7	90	<b>190.120.11</b>
12,7	1/2	25,4	16	76,2	<b>190.505.11</b>
12,7	1/2	28,6	16	76,2	<b>190.506.11</b>
12,7	1/2	34,9	16	88,9	<b>190.507.11</b>
12,7	1/2	41,3	16	101,6	<b>190.508.11</b>
16		55	24	110	<b>190.160.11</b>
18		55	30	110	<b>190.180.11</b>

...up & down cut mortising bits

9,53	3/8	22,2	4,8	76,2	<b>190.513.11</b>
12,7	1/2	22,2	5,2	76,2	<b>190.515.11</b>
12,7	1/2	34,9	5,2	88,9	<b>190.517.11</b>

**TECHNICAL DETAILS:**

- Premium quality HWM
- 2+2 spiral cutting edges (Z2+2)
- Provides an excellent finish on both the upper and lower sides of the workpiece

**APPLICATION:** used for cutting, copying, panel sizing and any routing applications in solid wood, wood composites, plastic materials and laminates. Use a high feed speed on well-clamped workpieces. Can be used on machining centres, point to point machines, CNC routers and hand-held routers equipped with chucks or adaptors.

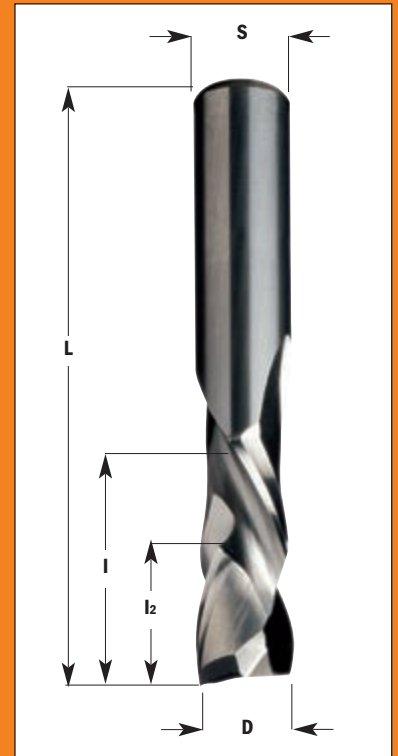

...up cut

**197** HWM Z4 [2+2R]

S=D Cutting diameter		I Cutting length	L Overall length	ORDER NO. Right-hand rotation
mm	mm	mm	mm	
12		42	90	<b>197.121.11</b>
14		50	110	<b>197.140.11</b>
16		55	110	<b>197.160.11</b>
16		35	90	<b>197.161.11</b>
18		55	110	<b>197.180.11</b>
20		60	120	<b>197.200.11</b>
20		70	120	<b>197.201.11</b>

**TECHNICAL DETAILS:**

- Premium quality HWM
- 4 spiral cutting edges (2 with chip-breaker) [Z2+2R]
- Tooth depth max 0.1mm
- Provides excellent finish on the lower side of the workpiece
- Upward chip ejection

**APPLICATION:** used for ripping, template routing, panel sizing and any routing applications in solid wood and wood composites. Can be used on machining centres, point to point machines, CNC routers and hand-held routers equipped with chucks or adaptors.

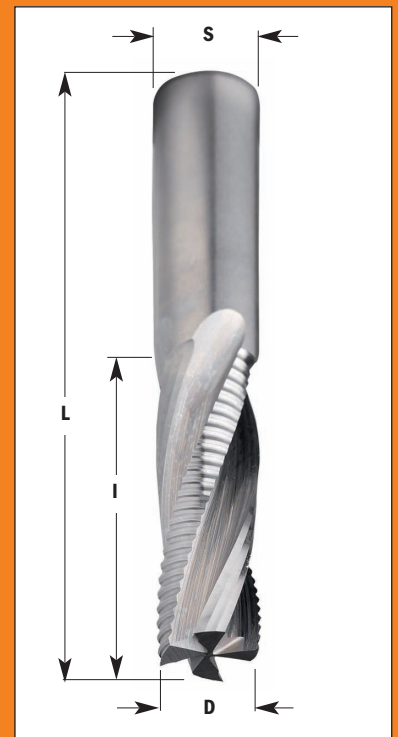

**The special 4 flutes design (Z2 finishing + Z2R with chipbreaker) allows high speed with excellent finish of the workpiece.**



...up cut with chip-breaker

**195** HWM Z3R

S=D	Cutting diameter		I	L	ORDER NO.	ORDER NO.
	mm	inches				
8			32	80	<b>195.081.11</b>	<b>195.081.12</b>
<b>new</b> 8			42	90	<b>195.082.11</b>	
10			32	80	<b>195.100.11</b>	<b>195.100.12</b>
10			42	90	<b>195.101.11</b>	
12			35	80	<b>195.120.11</b>	<b>195.120.12</b>
12			42	90	<b>195.121.11</b>	
<b>new</b> 12			52	100	<b>195.122.11</b>	
12,7	1/2		38,1	88,9	<b>195.506.11</b>	
14			58	110	<b>195.140.11</b>	
15,88	5/8		54	109,5	<b>195.509.11</b>	
16			55	110	<b>195.160.11</b>	<b>195.160.12</b>
16			35	90	<b>195.161.11</b>	
18			55	110	<b>195.180.11</b>	
19,05	3/4		54	109,5	<b>195.511.11</b>	
20			60	120	<b>195.200.11</b>	<b>195.200.12</b>
20			70	120	<b>195.201.11</b>	

**TECHNICAL DETAILS:**

- Premium quality HWM
- 3 spiral cutting edges (Z3R)
- Chip breaker teeth
- Tooth depth max 0.3mm
- Provides an excellent finish on the lower side of the workpiece
- Upward chip ejection

**APPLICATION:** used for ripping, template routing, panel sizing and any routing applications in solid wood, or wood composites. Can be used at a high feed speed on well-clamped workpieces. Can be used on machining centres, point to point machines, CNC routers and hand-held routers equipped with chucks or adaptors.

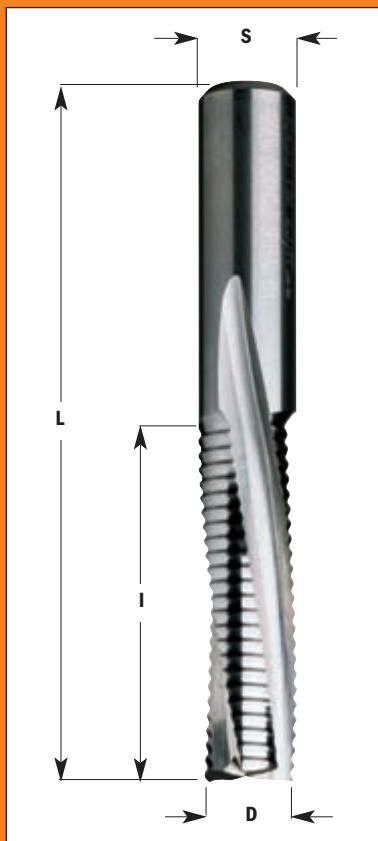

...down cut with chip-breaker

**196** HWM Z3R

S=D	Cutting diameter		I	L	ORDER NO.	ORDER NO.
	mm	inches				
8			32	80	<b>196.081.11</b>	
10			42	90	<b>196.101.11</b>	
12			35	80	<b>196.120.11</b>	<b>196.120.12</b>
12,7	1/2		38,1	88,9	<b>196.506.11</b>	
14			50	110	<b>196.140.11</b>	
15,88	5/8		54	109,5	<b>196.509.11</b>	
16			55	110	<b>196.160.11</b>	<b>196.160.12</b>
18			55	110	<b>196.180.11</b>	
19,05	3/4		54	109,5	<b>196.511.11</b>	
20			60	120	<b>196.200.11</b>	<b>196.200.12</b>

**TECHNICAL DETAILS:**

- Premium quality HWM
- 3 spiral cutting edges (Z3R)
- Chip breaker teeth
- Tooth depth max 0.3mm
- Provides excellent finish on the upper side of the workpiece
- Downward chip ejection.

**APPLICATION:** used for ripping, template routing, panel sizing and any routing applications in solid wood and wood composites. Can be used on machining centres, point to point machines, CNC routers and hand-held routers equipped with chucks or adaptors.

...up cut

**193 HWM Z3**

S=D Cutting diameter mm	I Cutting length mm	L Overall length mm	ORDER NO. Right-hand rotation	ORDER NO. Left-hand rotation
8	32	80	<b>193.081.11</b>	<b>193.081.12</b>
10	32	80	<b>193.100.11</b>	<b>193.100.12</b>
10	42	90	<b>193.101.11</b>	
12	35	80	<b>193.120.11</b>	<b>193.120.12</b>
12	42	90	<b>193.121.11</b>	
14	58	110	<b>193.140.11</b>	
16	55	110	<b>193.160.11</b>	<b>193.160.12</b>
16	35	90	<b>193.161.11</b>	
18	55	110	<b>193.180.11</b>	
20	60	120	<b>193.200.11</b>	<b>193.200.12</b>
20	70	120	<b>193.201.11</b>	

**TECHNICAL DETAILS:**

- Premium quality HWM
- 3 spiral cutting edges (Z3)
- Provides an excellent finish on the lower side of the workpiece
- Upward chip ejection

**APPLICATION:** used for ripping, template routing, panel sizing and any routing applications in solid wood, or wood composites. Can be used at a high feed speed on well-clamped workpieces. Can be used on machining centres, point to point machines, CNC routers and hand-held routers equipped with chucks or adaptors.

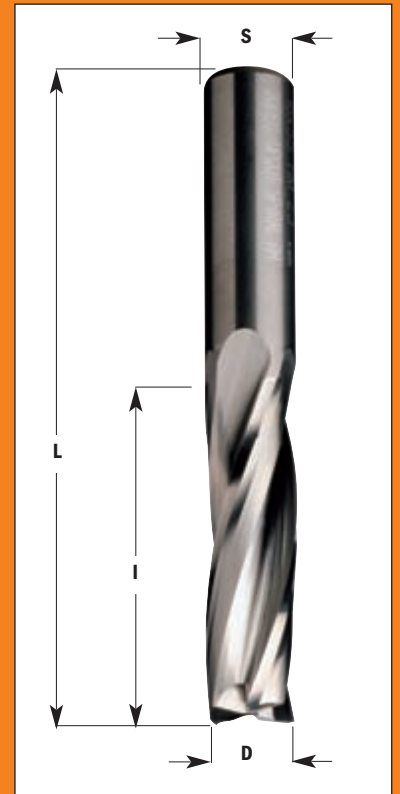

...down cut

**194 HWM Z3**

S=D Cutting diameter mm	I Cutting length mm	L Overall length mm	ORDER NO. Right-hand rotation	ORDER NO. Left-hand rotation
10	32	80	<b>194.100.11</b>	
12	35	80	<b>194.120.11</b>	<b>194.120.12</b>
14	50	110	<b>194.140.11</b>	
16	55	110	<b>194.160.11</b>	<b>194.160.12</b>
16	35	90	<b>194.161.11</b>	
18	55	110	<b>194.180.11</b>	
20	60	120	<b>194.200.11</b>	<b>194.200.12</b>

**TECHNICAL DETAILS:**

- Premium quality HWM
- 3 spiral cutting edges (Z3)
- Provides an excellent finish on the upper side of the workpiece
- Downward chip ejection

**APPLICATION:** used for ripping, template routing, panel sizing and any routing applications in solid wood, wood composites, plastic materials and laminates. Can be used at a high feed speed on small, difficult to clamp workpieces. Can be used on machining centres, point to point machines, CNC routers and hand-held routers equipped with chucks or adaptors.

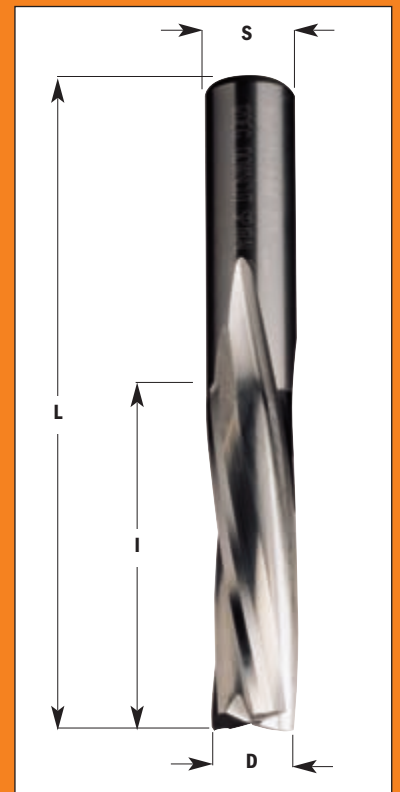



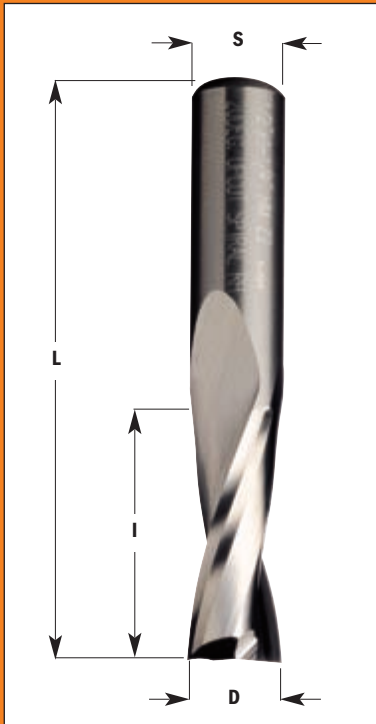

**191 HWM Z2**

...up cut

D Cutting diameter mm inches		I Cutting length mm	L Overall length mm	S Shank diameter mm	ORDER NO. Right-hand rotation
3		12	50	3	<b>191.030.11</b>
3		12	60	6	<b>191.630.11</b>
3		12	60	8	<b>191.830.11</b>
3,18	1/8	12,7	50,8	6,35	<b>191.001.11</b>
3,5		12	60	6	<b>191.635.11</b>
3,97	5/32	12,7	50,8	6,35	<b>191.003.11</b>
4		15	50	4	<b>191.040.11</b>
4		15	60	6	<b>191.640.11</b>
4		15	60	8	<b>191.840.11</b>
4,76	3/16	19,05	50,8	6,35	<b>191.005.11</b>
5		17	50	5	<b>191.050.11</b>
5		17	60	6	<b>191.650.11</b>
5		17	60	8	<b>191.850.11</b>
6		27	70	6	<b>191.060.11</b>
6		22	70	8	<b>191.860.11</b>
6,35	1/4	19,05	50,8	6,35	<b>191.007.11</b>
6,35	1/4	25,4	63,5	6,35	<b>191.008.11</b>
7		32	80	8	<b>191.870.11</b>
7,94	5/16	25,4	76,2	12,7	<b>191.501.11</b>
8		22	70	8	<b>191.080.11</b>
8		32	80	8	<b>191.081.11</b>
<b>new</b> 8		42	90	8	<b>191.082.11</b>
9		32	80	12	<b>191.890.11</b>
9,53	3/8	31,75	76,2	12,7	<b>191.503.11</b>
10		32	80	8	<b>191.800.11</b>
10		32	80	10	<b>191.100.11</b>
10		32	80	12	<b>191.900.11</b>
10		42	90	10	<b>191.101.11</b>
10		42	90	12	<b>191.901.11</b>
12		35	80	8	<b>191.820.11</b>
12		35	80	12	<b>191.120.11</b>
12		42	90	12	<b>191.121.11</b>
<b>new</b> 12		52	100	12	<b>191.122.11</b>
12,7	1/2	31,75	76,2	12,7	<b>191.505.11</b>
12,7	1/2	38,1	88,9	12,7	<b>191.506.11</b>
12,7	1/2	50,8	101,6	12,7	<b>191.507.11</b>
14		50	110	14	<b>191.140.11</b>
15,88	5/8	55	109,5	15,88	<b>191.509.11</b>
16		55	110	16	<b>191.160.11</b>
16		35	90	16	<b>191.161.11</b>
19,05	3/4	55	109,5	19,05	<b>191.511.11</b>
20		60	120	20	<b>191.200.11</b>

**TECHNICAL DETAILS:**

- Premium quality HWM
- 2 spiral cutting edges (Z2)
- Provides an excellent finish on the lower side of the workpiece
- Upward chip ejection

**APPLICATION:** used for ripping, template routing, panel sizing and any routing applications in solid wood, wood composites, plastic materials and laminates.

Can be used at a high feed speed on well-clamped workpieces. Can be used on machining centres, point to point machines, CNC routers and hand-held routers equipped with chucks or adaptors.

**...down cut**
**192 HWM Z2**

D Cutting diameter		I Cutting length	L Overall length	S Shank diameter	ORDER NO. Right-hand rotation
mm	inches	mm	mm	mm	
3		12	50	3	<b>192.030.11</b>
3		12	60	6	<b>192.630.11</b>
3		12	60	8	<b>192.830.11</b>
3,18	1/8	12,7	50,8	6,35	<b>192.001.11</b>
3,97	5/32	12,7	50,8	6,35	<b>192.003.11</b>
4		15	50	4	<b>192.040.11</b>
4		15	60	6	<b>192.640.11</b>
4		15	60	8	<b>192.840.11</b>
4,76	3/16	19,05	50,8	6,35	<b>192.005.11</b>
5		17	50	5	<b>192.050.11</b>
5		17	60	6	<b>192.650.11</b>
5		17	60	8	<b>192.850.11</b>
6		22	70	6	<b>192.060.11</b>
6		22	70	8	<b>192.860.11</b>
6,35	1/4	19,05	50,8	6,35	<b>192.007.11</b>
6,35	1/4	25,4	63,5	6,35	<b>192.008.11</b>
7,94	5/16	25,4	76,2	12,7	<b>192.501.11</b>
8		22	70	8	<b>192.080.11</b>
8		32	80	8	<b>192.081.11</b>
<small>new</small> 8		42	90	8	<b>192.082.11</b>
9,53	3/8	31,75	76,2	12,7	<b>192.503.11</b>
10		32	80	8	<b>192.800.11</b>
10		32	80	10	<b>192.100.11</b>
10		32	80	12	<b>192.900.11</b>
12		35	80	8	<b>192.820.11</b>
12		35	80	12	<b>192.120.11</b>
12,7	1/2	31,75	76,2	12,7	<b>192.505.11</b>
12,7	1/2	38,1	88,9	12,7	<b>192.506.11</b>
12,7	1/2	50,8	101,6	12,7	<b>192.507.11</b>
16		55	110	16	<b>192.160.11</b>

**TECHNICAL DETAILS:**

- Premium quality HWM
- 2 spiral edges (Z2)
- Provides an excellent finish on the upper side of the workpiece
- Downward chip ejection

**APPLICATION:** used for ripping, template routing, panel sizing and any routing applications in solid wood, wood composites, plastic materials and laminates. Can be used at a high feed speed on small, difficult to clamp work pieces.

Can be used on machining centres, point to point machines, CNC routers and hand-held routers equipped with chucks or adaptors.

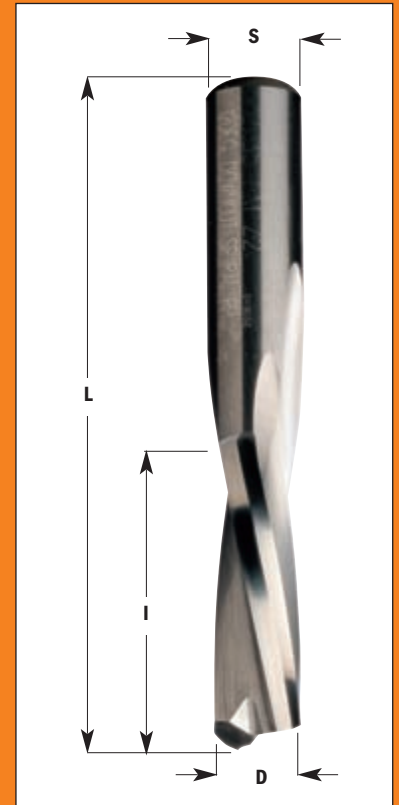

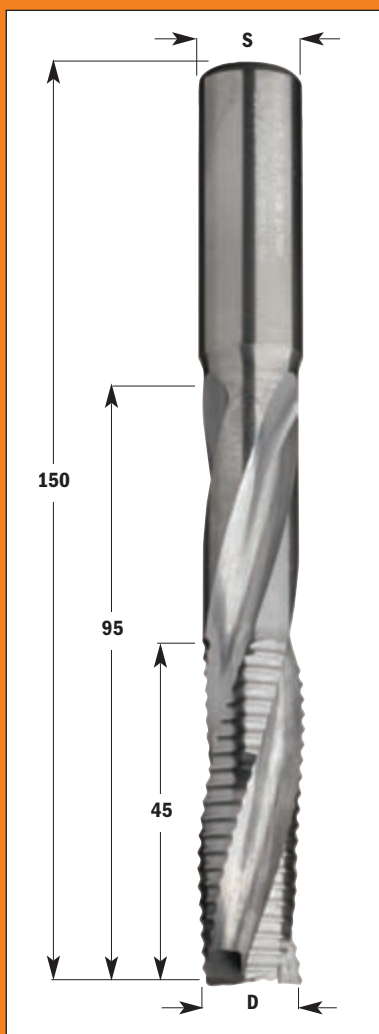

...up cut, for lockset with chip-breaker

**195** HWM Z3R

S=D Cutting diameter mm	I Cutting length mm	L Overall length mm	ORDER NO. Right-hand rotation
14	95*	150	<b>195.142.11</b>
16	95*	150	<b>195.162.11</b>
18	95*	150	<b>195.182.11</b>

\* The length 95mm is made in 2-3 passes.

**TECHNICAL DETAILS:**

- Premium quality HWM
- 3 spiral cutting edges (Z3R)
- Chip breaker teeth
- Tooth depth max 0.3mm
- Provides an excellent finish on the lower side of the workpiece
- Upward chip ejection

**APPLICATION:** used for ripping, template routing, panel sizing and any routing applications in solid wood, or wood composites. Can be used at a high feed speed on well-clamped workpieces. Can be used on machining centres, point to point machines, CNC routers and hand-held routers equipped with chucks or adaptors.

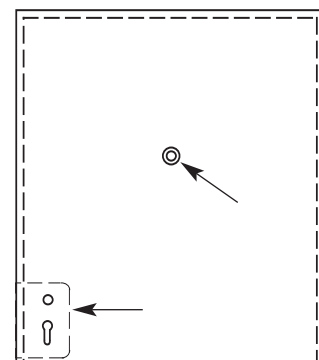

...up cut with chipbreaker,  
for lockset with 60° V-Point

**195.143/163** HWM Z3R

S=D Cutting diameter mm	I Cutting length mm	L Overall length mm	ORDER NO. Right-hand rotation
14	58	110	<b>195.143.11</b>
16	55	110	<b>195.163.11</b>

...up cut without chipbreaker,  
for lockset with 60° V-Point

**191.143/163** HWM Z3

S=D Cutting diameter mm	I Cutting length mm	L Overall length mm	ORDER NO. Right-hand rotation
14	50	110	<b>191.143.11</b>
16	55	110	<b>191.163.11</b>

**TECHNICAL DETAILS:**

- Premium quality HWM
- 3 spiral cutting edges (Z3)
- Provides an excellent finish on the lower side of the workpiece
- Upward chip ejection

**APPLICATION:** used for ripping, template routing, panel sizing and any routing applications in solid wood, or wood composites.

Can be used at a high feed speed on well-clamped workpieces. Can be used on machining centres, point to point machines, CNC routers and hand-held routers equipped with chucks or adaptors.

...for lockset with chip-breaker

**662 HWM Z2R**

S=D Cutting diameter mm	I Cutting length mm	L Overall length mm	ORDER NO. Right-hand rotation
16	23/95*	150	<b>662.160.11</b>

**Spare parts**

Knives 23x7x1.5mm 2-RT HW-HC	<b>790.230.2R</b>
Knives 23x7x1.5mm 3-RT HW-HC	<b>790.230.3R</b>
Screw Torx T9 M3x4	<b>990.082.00</b>
Torx key T9	<b>991.069.00</b>

\* The length 95mm is made in several passes.

**TECHNICAL DETAILS:**

- Super Strength steel (heavy-duty material)
- 2 cutting edges (Z2R)
- Chip breaker teeth

**APPLICATION:** used for ripping, template routing, panel sizing and any routing applications in solid wood, or wood composites. Can be used at a high feed speed on well-clamped workpieces. Can be used on machining centres, point to point machines, CNC routers and hand-held routers equipped with chucks or adaptors.

Cost effective solution compared to brazed router bits and solid carbide spiral bits.

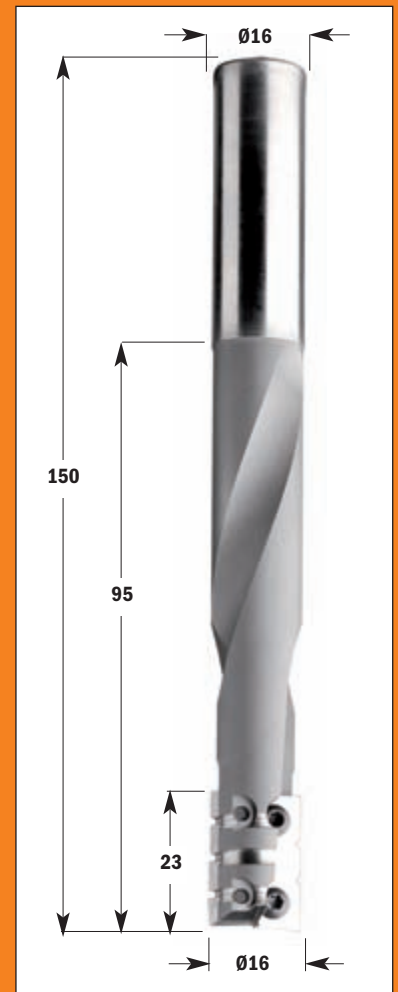
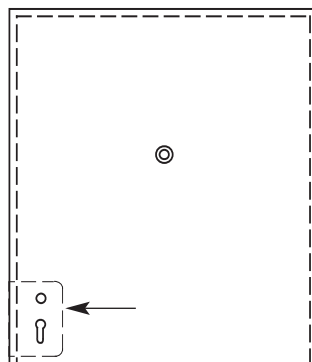

Spoilboard surfacing router cutters

Shank Ø20mm

**663.001.11 HW Z2+2**

D Cutting diameter mm	I Cutting length mm	L Overall length mm	ORDER NO. Right-hand rotation
80	12	90	<b>663.001.11</b>

**Spare parts**

Knives 12x12x1,5mm	<b>790.120.00</b>
Screw Torx T15 M4x6	<b>990.075.00</b>
Torx key T15	<b>991.061.00</b>
Knives 14x14x2mm	<b>790.140.00</b>
Screw Torx T20 M6x9	<b>990.083.00</b>
Torx key T20	<b>991.072.00</b>

**TECHNICAL DETAILS:**

- Super Strength steel
- 2 cutting edges (Z2)
- 2 scores knives (V2)

**APPLICATION:** new router bit for CNC router ideal for fast removal of material over a large surface area leaving an improved finish at the bottom of the cut. Used on soft and hard woods, particle board and MDF . The router bit utilizes 4-sided HWM inserts.

Cost effective solution compared to brazed router bits and solid carbide spiral bits.

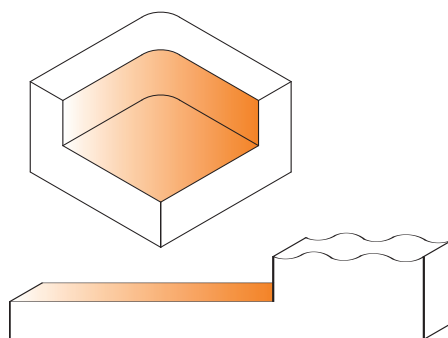

Drawings are 1:2 scale

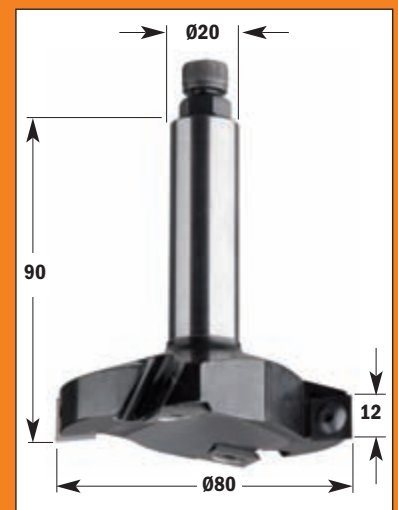



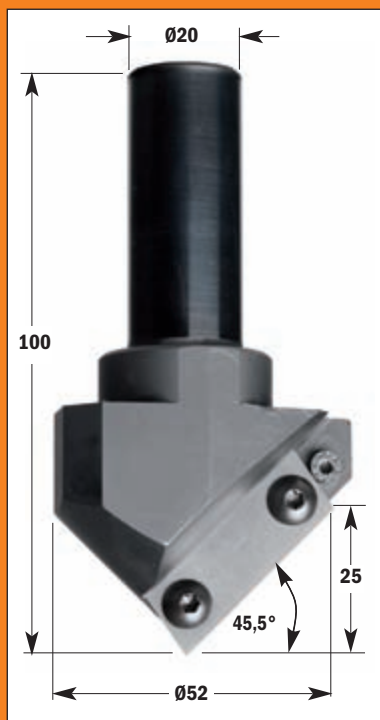

**Shank Ø20mm**

**663.101.11 HW Z1**

D Cutting diameter mm	I Cutting length mm	L Overall length mm	ORDER NO. Right-hand rotation	
52	25	100	<b>663.101.11</b>	

**Spare parts**

Knives 36x12x1,5mm	<b>790.360.01</b>
Screw Torx M3,5x7	<b>990.077.00</b>
Torx key T15	<b>991.061.00</b>

**TECHNICAL DETAILS:**

- Super Strength steel
- 1 cutting edges (Z1)

**APPLICATION:** this innovative CNC router bit offer you endless range of possibilities for V-groove, miter folds, signmaking, lettering and chamfer edges.

The tool mount a high grade of HWM reversible knife ideal for general purpose, chipboard and plywood but an higher quality is available for laminated and MDF material.

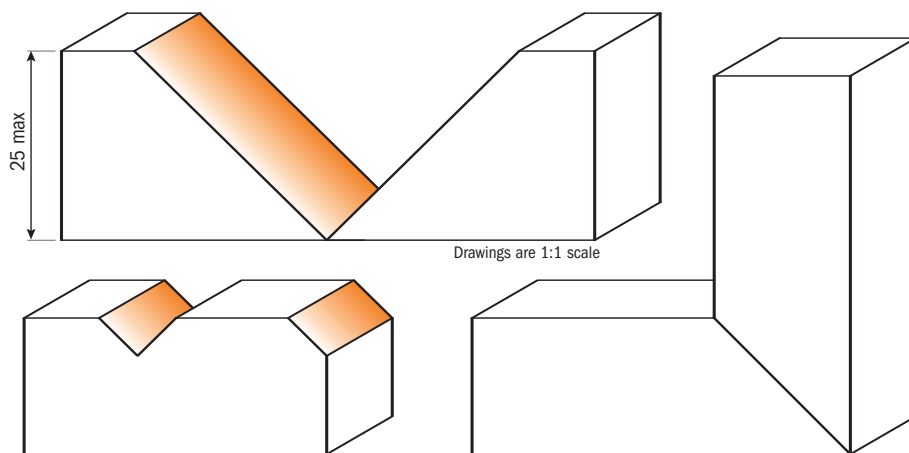

**Straight router cutters with knives**

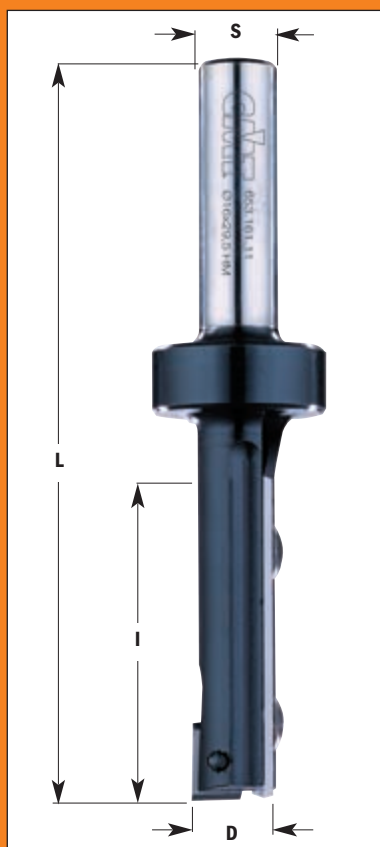

**Shank Ø20mm**

**653 HW Z1+1**

D Cutting diameter mm	I Cutting length mm	L Overall length mm	Spare knives		ORDER NO. Right-hand rotation
			side	top	
16	28,3	91,5	790.283.12	790.075.00	<b>653.661.11</b>
16	48,3	111,5	790.483.12	790.075.00	<b>653.662.11</b>
18	48,3	111,5	790.483.12	790.075.00	<b>653.681.11</b>
20	48,3	111,5	790.483.12	790.096.00	<b>653.701.11</b>

**Spare parts**

Knives 7,5 x 12 x 1,5mm	<b>790.075.00</b>
Knives 9,6 x 12 x 1,5mm	<b>790.096.00</b>
Knives 28,3 x 12 x 1,5mm	<b>790.283.12</b>
Knives 48,3 x 12 x 1,5mm	<b>790.483.12</b>
Torx screw M3,5x3,5mm	<b>990.072.00</b>
Torx screw M4x3,5mm	<b>990.074.00</b>
Torx screw M4x6mm	<b>990.075.00</b>
Torx key T15	<b>991.061.00</b>

**TECHNICAL DETAILS:**

- Super Strength steel
- 2 cutting edges (Z1+1)

**APPLICATION:** straight router bit with one replaceable plunging knife and one side knife fixed by special Torx screws. The body is precise balanced. For finishing and routing, plunge cutting and grooving in boards materials (laminated chipboards, MDF) and hard wood.

For use on CNC machining centers.



**140 DP Z1+1**

D Cutting diameter		I Cutting length	L Overall length	S Shank diameter	Z No. of teeth	ORDER NO. Right-hand rotation
mm	inches	mm	mm	mm		
12		27	70	12x35	1+1 (3 DP)	<b>140.120.61</b>
12		36	80	12x35	1+1 (4 DP)	<b>140.121.61</b>
12,7	1/2	27	70	12,7	1+1 (3 DP)	<b>140.127.61</b>
12,7	1/2	36	80	12,7	1+1 (4 DP)	<b>140.128.61</b>
15,87	5/8	27	85	15,87	1+1 (3 DP)	<b>140.158.61</b>
15,87	5/8	45	100	15,87	1+1 (5 DP)	<b>140.159.61</b>
16		27	90	16x50	1+1 (3 DP)	<b>140.160.61</b>
16		36	95	16x45	1+1 (4 DP)	<b>140.161.61</b>
18		27	80	16x45	1+1 (3 DP)	<b>140.180.61</b>
18		36	90	16x45	1+1 (4 DP)	<b>140.181.61</b>
18		45	100	16x45	1+1 (5 DP)	<b>140.182.61</b>
19,05	3/4	27	90	19,05	1+1 (3 DP)	<b>140.190.61</b>
19,05	3/4	45	105	19,05	1+1 (5 DP)	<b>140.192.61</b>
20		27	85	20x50	1+1 (3 DP)	<b>140.200.61</b>
20		36	95	20x50	1+1 (4 DP)	<b>140.201.61</b>
20		45	105	20x50	1+1 (5 DP)	<b>140.202.61</b>
20		54	115	20x50	1+1 (6 DP)	<b>140.203.61</b>

**TECHNICAL DETAILS:**

- Super strength steel
- DP cutting edge
- HW plunging tip
- Resharpener cutter (max 3 times)

**APPLICATION:** for routing and sizing ultra-hard and abrasive material.

Can be used at high feed speed (3-10 m/min.)

Can be used on machining centres, CNC routers equipped with chucks or adaptors.



**141 DP Z1**

D Cutting diameter		I Cutting length	L Overall length	S Shank diameter	Z No. of teeth	ORDER NO. Right-hand rotation
mm	mm	mm	mm	mm		
6		8	55	12x35	1	<b>141.060.61</b>
8		12	60	12x35	1	<b>141.080.61</b>
*10		22	65	12x35	1+1	<b>141.101.61</b>

**TECHNICAL DETAILS:**

- Super strength steel
- DP cutting edge
- HW plunging tip
- Resharpener cutter (max 3 times)

**APPLICATION:** for routing and sizing ultra-hard and abrasive material.

Can be used at high feed speed (3-5 m/min.)

Can be used on machining centres, CNC routers equipped with chucks or adaptors.



**\* CONSTRUCTIONS  
Z1+1  
FOR CODE  
141.101.61**



**615.004.01**



Open some new doors with CMT. Our 4-piece set includes the most popular profile to make MDF panel doors for kitchens and bathrooms. Each bit is made from bar stock steel and the highest quality tungsten carbide knives.

The bodies support 5 different profiles knives allowing enormous possibilities for easy and economical construction.

The highest materials, the lowest tolerance in balancing and the precision in the sharpening of the knives, let you obtain a smooth finish on your CNC machine.



- Spare parts:**
- 991.061.00** Torx key T15
  - 990.073.00** Torx screw M3,5x5
  - 990.075.00** Torx screw M4x6
  - 990.077.00** Torx screw M3,5x7

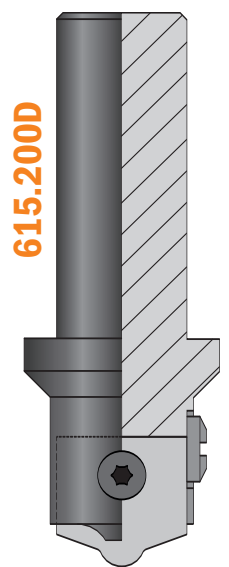
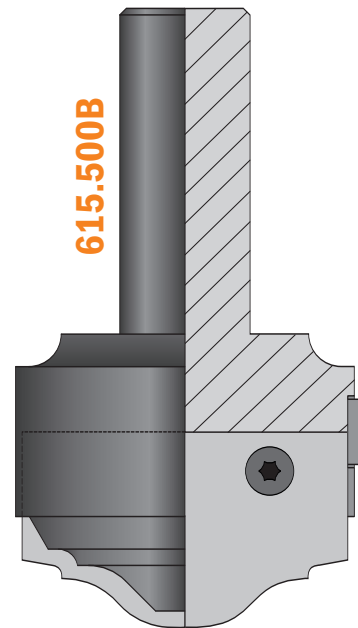
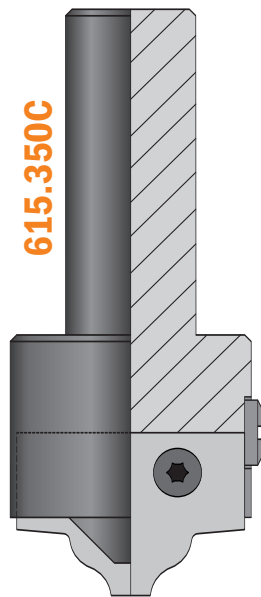
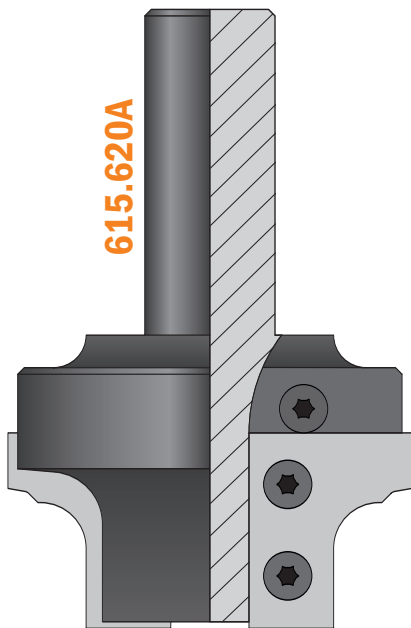
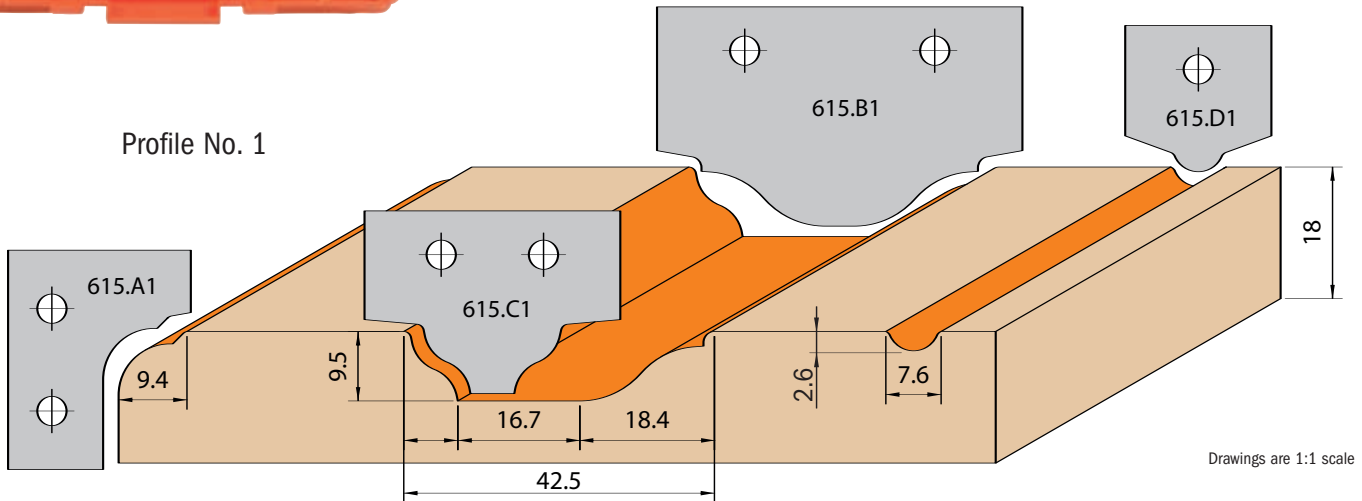

DESCRIPTION

ORDER NO.  
Shank  
Ø 20mm

Complete set for MDF doors (Profile no. 1)

**615.004.01**

Profile No. 2 (optional)

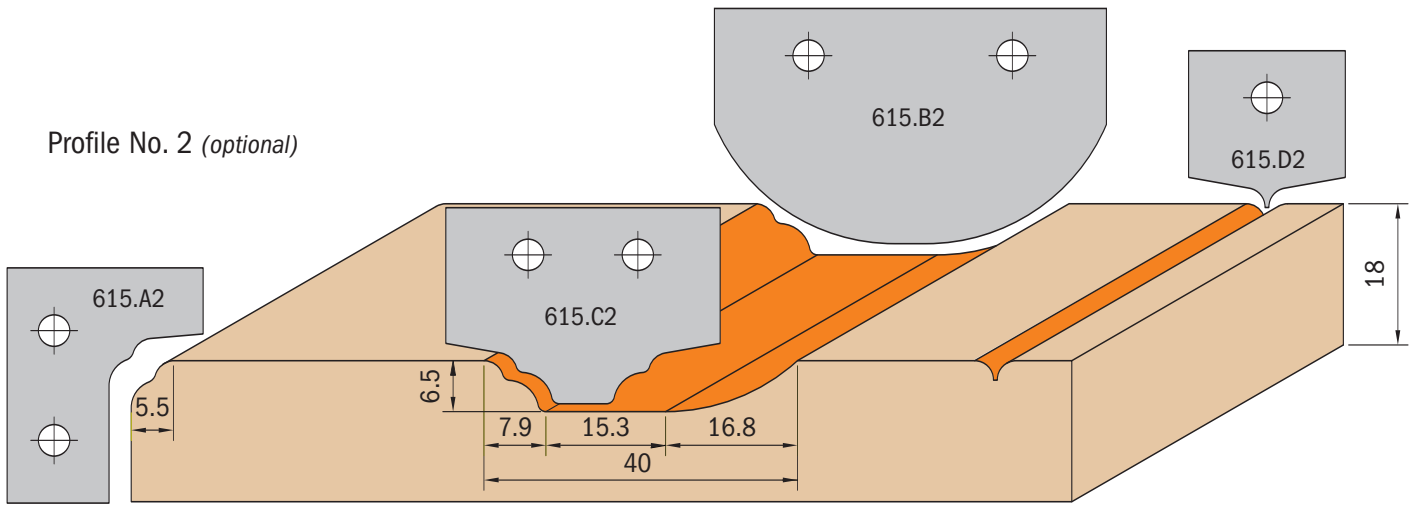

Profile No. 3 (optional)

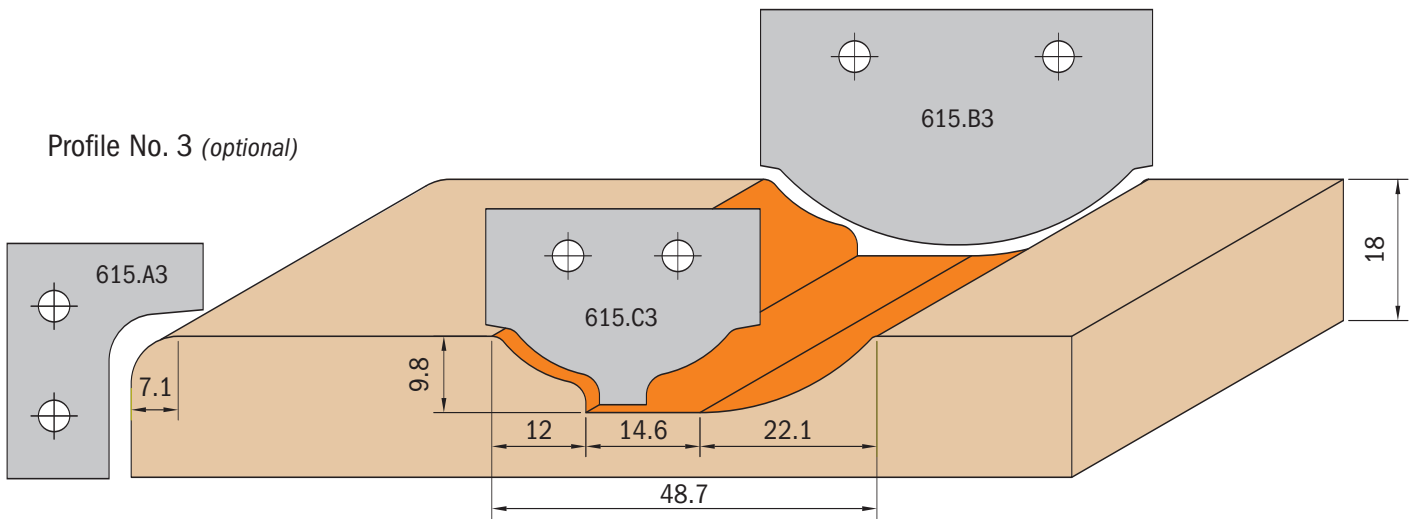

Profile No. 4 (optional)

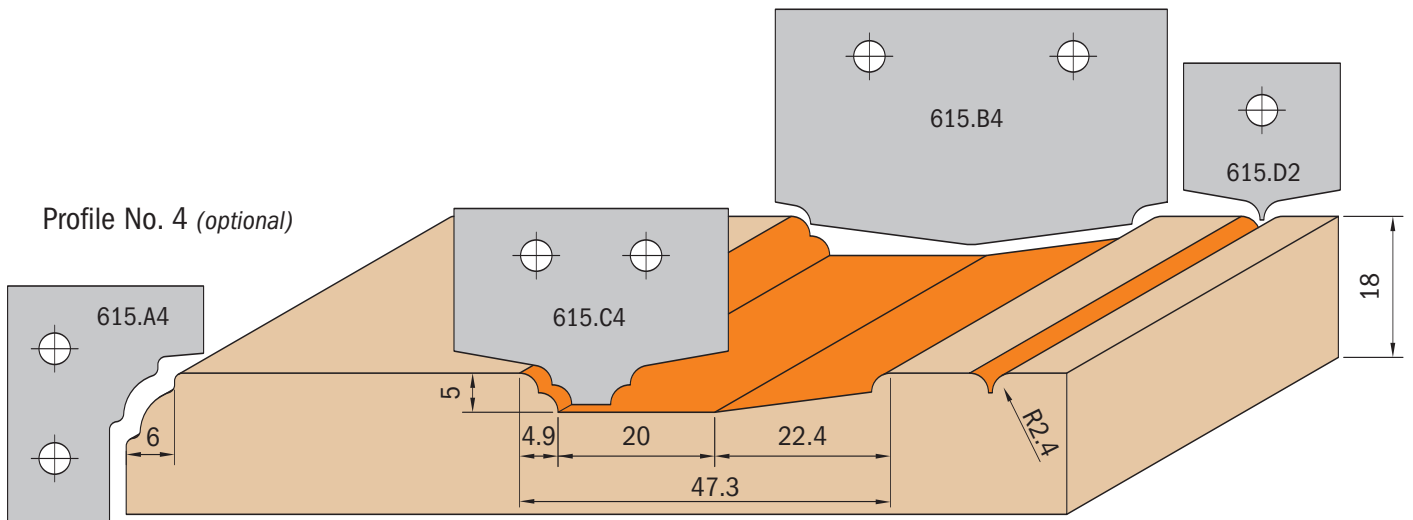

Profile No. 5 (optional)

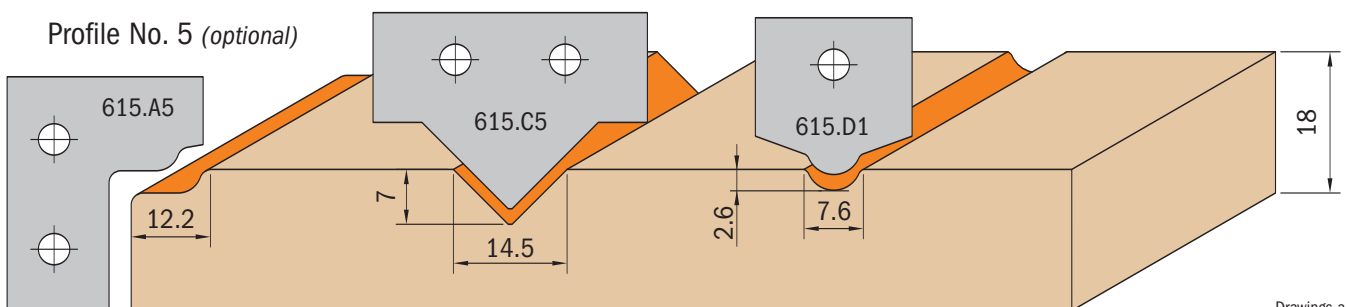

Drawings are 1:1 scale



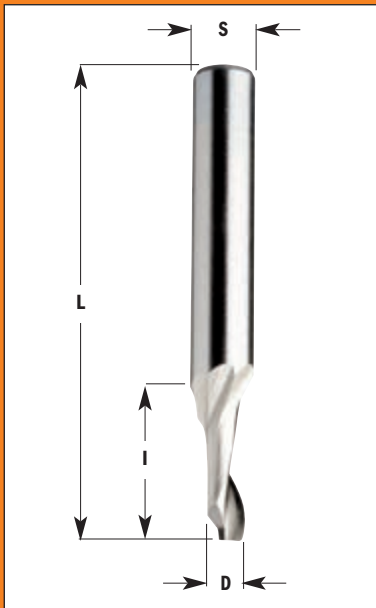

... positive single flute

**188** HS 5%co Z1

D Cutting diameter mm	I Cutting length mm	L Overall length mm	S Shank diameter mm	ORDER NO. Right-hand rotation
3	12	60	8	<b>188.030.51</b>
4	12	60	8	<b>188.040.51</b>
4	40	100	8	<b>188.041.51</b>
5	14	60	8	<b>188.050.51</b>
5	40	100	8	<b>188.051.51</b>
6	14	60	8	<b>188.060.51</b>
6	40	100	8	<b>188.061.51</b>
7	14	60	8	<b>188.070.51</b>
8	14	80	8	<b>188.080.51</b>
8	40	100	8	<b>188.081.51</b>
9	14	80	8	<b>188.090.51</b>
10	14	80	8	<b>188.100.51</b>
12	14	80	8	<b>188.120.51</b>

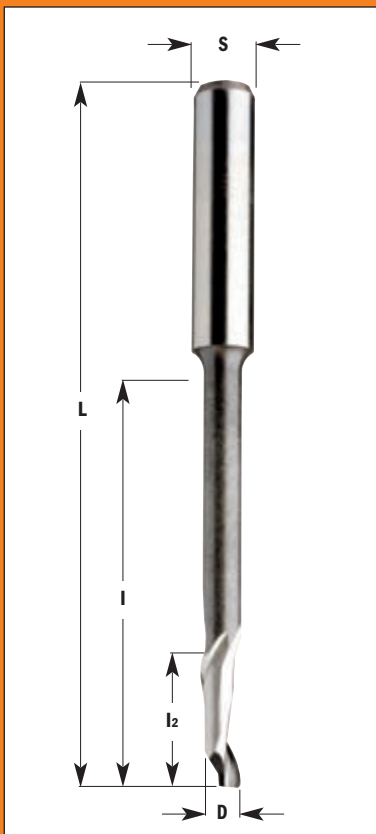

..... positive single flute for high cutting depth

**189** HS 5%co Z1

D Cutting diameter mm	I Cutting length mm	I <sub>2</sub> Cutting length mm	L Overall length mm	S Shank diameter mm	ORDER NO. Right-hand rotation
4	46	16	90	8	<b>189.040.51</b>
5	35	18	80	8	<b>189.050.51</b>
5	35	14	120	8	<b>189.051.51</b>
5	55	16	90	8	<b>189.052.51</b>
6	45	16	90	8	<b>189.060.51</b>
8	68	14	100	8	<b>189.080.51</b>
8	55	14	80	8	<b>189.081.51</b>
10	95	14	120	10	<b>189.100.51</b>
10	70	30	100	10	<b>189.101.51</b>

**TECHNICAL DETAILS:**

- Premium quality solid HS 5%co
- 1 up cut spiral cutting edge
- Upward chip ejection

**APPLICATION:** the single flute design of these tools, which carves rather than pushes the material, makes them equally effective in all types of aluminum.

The end result is that the tools provide more flexibility than the traditional bits, better finishes and higher productivity.

**Shank Ø8mm**
**174 HWM Z2+1**

D Cutting diameter mm	I Cutting length mm	L Overall length mm	ORDER NO. Right-hand rotation
3	10	55	<b>174.030.11</b>
4	10	55	<b>174.040.11</b>
5	12	55	<b>174.050.11</b>
6	14	55	<b>174.060.11</b>
7	20	55	<b>174.070.11</b>
8	20	55	<b>174.080.11</b>
9	20	55	<b>174.090.11</b>

**TECHNICAL DETAILS:**

- Premium quality HWM
- 2 radial relief cutting edges (Z2)

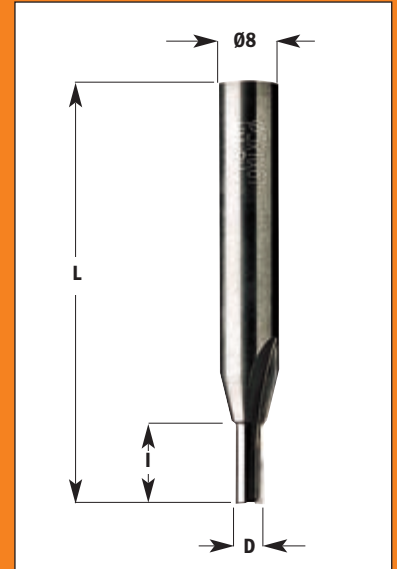

**Shank Ø8mm**
**174 HW Z2+1**

D Cutting diameter mm	I Cutting length mm	L Overall length mm	ORDER NO. Right-hand rotation
10	20	60	<b>174.100.11</b>
10	40	90	<b>174.101.11</b>
11	20	60	<b>174.110.11</b>
12	20	60	<b>174.120.11</b>
12	40	90	<b>174.121.11</b>
13	20	60	<b>174.130.11</b>
14	20	60	<b>174.140.11</b>
14	40	90	<b>174.141.11</b>
15	20	60	<b>174.150.11</b>
16	20	70	<b>174.160.11</b>
16	40	90	<b>174.161.11</b>
18	20	70	<b>174.180.11</b>
20	20	70	<b>174.200.11</b>
22	20	70	<b>174.220.11</b>
24	20	70	<b>174.240.11</b>
26	20	70	<b>174.260.11</b>
28	20	70	<b>174.280.11</b>
30	20	70	<b>174.300.11</b>

**TECHNICAL DETAILS:**

- Super strength steel
- 2 precision ground HW cutting edges and 1 HW plunge centre tip (Z2+1)

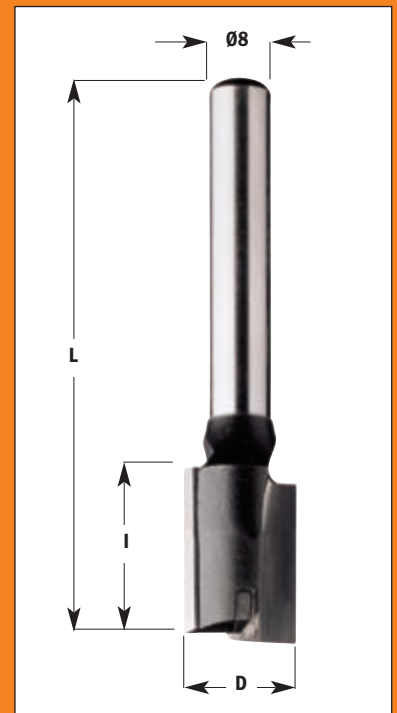
**APPLICATION:** used for drilling, grooving or jointing solid wood and wood composites.  
Can be used on machining centres, CNC routers and hand-held routers equipped with chucks or adaptors.

**HW plunge centre tip**

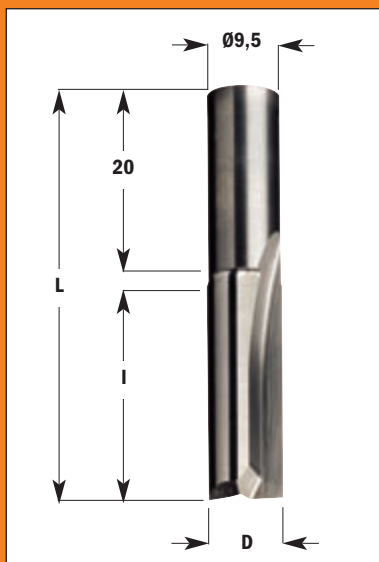

Shank Ø9,5x20mm

**112** HWM Z2+1

D Cutting diameter mm	I Cutting length mm	L Overall length mm	ORDER NO. Right-hand rotation
3	10	37	<b>112.030.11</b>
4	10	37	<b>112.040.11</b>
5	12	39	<b>112.050.11</b>
6	14	41	<b>112.060.11</b>
7	16	43	<b>112.070.11</b>
8	18	48	<b>112.080.11</b>
8	30	60	<b>112.081.11</b>
9	20	52	<b>112.090.11</b>
10*	22	52	<b>112.100.11</b>
10*	35	65	<b>112.101.11</b>
11*	26	52	<b>112.110.11</b>
12*	26	52	<b>112.120.11</b>

\* Super strength steel  
2 precision ground HW cutting edges [Z2]

**TECHNICAL DETAILS:**  
- Premium quality HWM  
- 2 radial relief cutting edges (Z2)



Shank Ø12mm

**113** HW Z2+1

D Cutting diameter mm	I Cutting length mm	L Overall length mm	ORDER NO. Right-hand rotation
12	26	52	<b>113.120.11</b>
12	40	70	<b>113.121.11</b>
13	26	52	<b>113.130.11</b>
14	28	56	<b>113.140.11</b>
14	40	72	<b>113.141.11</b>
15	32	60	<b>113.150.11</b>
16	32	60	<b>113.160.11</b>
16	40	72	<b>113.161.11</b>
17	35	64	<b>113.170.11</b>
18	35	64	<b>113.180.11</b>
19	38	68	<b>113.190.11</b>
20	38	68	<b>113.200.11</b>
22	40	72	<b>113.220.11</b>
24	40	72	<b>113.240.11</b>
25	40	72	<b>113.250.11</b>
26	42	74	<b>113.260.11</b>
28	42	74	<b>113.280.11</b>
30	42	74	<b>113.300.11</b>

**TECHNICAL DETAILS:**  
- Super strength steel  
- 2 precision ground HW cutting edges and 1 HW plunge centre tip (Z2+1)

**APPLICATION:** used for grooving, jointing and routing solid wood, wood composites, plastic materials and laminates.



HW plunge centre tip

**Shank Ø10x35mm**
**175 HW Z2+1**

D Cutting diameter mm	I Cutting length mm	L Overall length mm	ORDER NO. Right-hand rotation
4*	10	65	175.040.11
5*	12	65	175.050.11
6*	14	65	175.060.11
7*	17	65	175.070.11
8*	20	65	175.080.11
9*	23	65	175.090.11
10	25	70	175.100.11
12	25	70	175.120.11
14	25	70	175.140.11
15	25	70	175.150.11
16	25	70	175.160.11
18	25	70	175.180.11
20	25	70	175.200.11
22	25	70	175.220.11
24	25	70	175.240.11
25	25	70	175.250.11
26	25	70	175.260.11
30	25	70	175.300.11
35	25	70	175.350.11

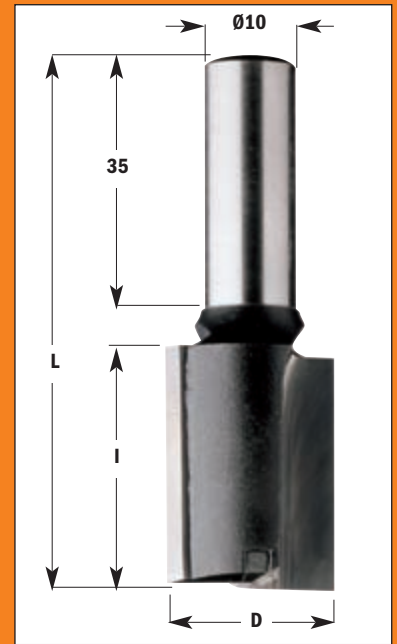
**Shank Ø10x35mm**
**176 HW Z2+1**

D Cutting diameter mm	I Cutting length mm	L Overall length mm	ORDER NO. Right-hand rotation
10	40	87	176.100.11
12	40	87	176.120.11
14	40	87	176.140.11
15	40	87	176.150.11
16	40	87	176.160.11
18	40	87	176.180.11
20	40	87	176.200.11

**HW plunge centre tip**
**Shank Ø12x50mm**
**177 HW Z2+1**

D Cutting diameter mm	I Cutting length mm	L Overall length mm	ORDER NO. Right-hand rotation
10	35	90	177.100.11
12	35	90	177.120.11
12	50	100	177.121.11
14	35	90	177.140.11
16	35	90	177.160.11
16	60	110	177.161.11
18	35	90	177.180.11
20	35	90	177.200.11
22	35	90	177.220.11
24	35	90	177.240.11
30	35	90	177.300.11
35	35	90	177.350.11

**TECHNICAL DETAILS:**

- Super strength steel
- 2 precision ground HW cutting edges and 1 HW plunge centre tip (Z2+1)

**APPLICATION:** used for grooving, jointing and general routing operations in solid wood, wood composites, plastics and laminates. Can be used on machining centres, CNC routers and hand-held routers.



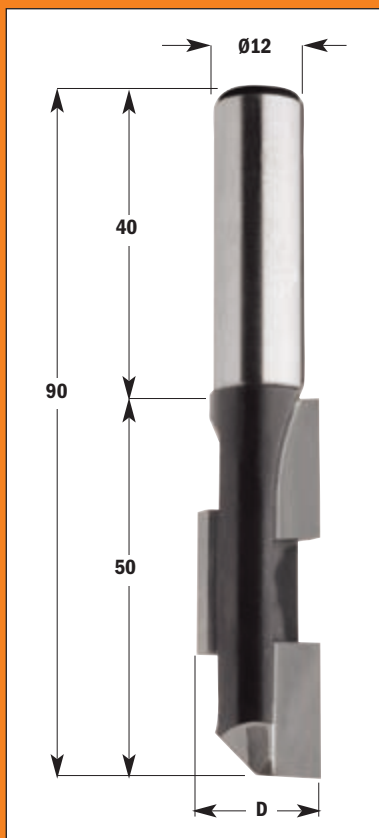

## Shank Ø12x40mm

**136 HW Z2+1**

D Cutting diameter mm	I Cutting length mm	L Overall length mm	ORDER NO. Right-hand rotation
14	50	90	<b>136.140.11</b>
16	50	90	<b>136.160.11</b>
18	50	90	<b>136.180.11</b>

### TECHNICAL DETAILS:

- Super strength steel
- 2 alternating precision ground HW [Z2+1]

**APPLICATION:** ideal for cutting openings for electrical boxes and similar operations in solid wood, wood composites, plastics and laminates. Can be used on machining centres, CNC routers and hand-held routers equipped with chucks or adaptors.

# Grooving cutters

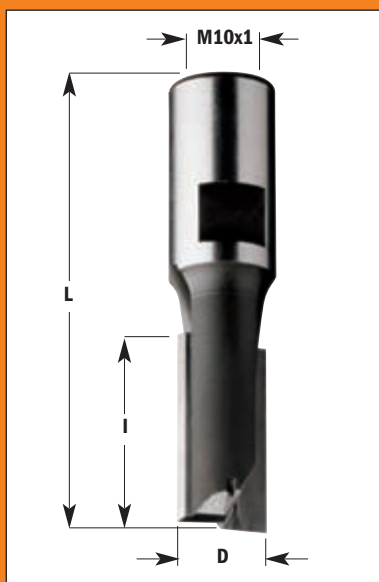

## Shank M10

**173-182 HW Z2+1**

D Cutting diameter mm	I Cutting length mm	L Overall length mm	ORDER NO. Right-hand rotation
6	14	50	<b>173.060.11</b>
8	20	52	<b>173.080.11</b>
10	22	52	<b>173.100.11</b>
12	22	52	<b>173.120.11</b>
14	25	52	<b>173.140.11</b>
15	25	52	<b>173.150.11</b>
16	25	52	<b>173.160.11</b>
18	25	52	<b>173.180.11</b>
20	25	52	<b>173.200.11</b>
22	25	52	<b>173.220.11</b>
25	25	52	<b>173.250.11</b>
30	25	52	<b>173.300.11</b>
8	35	67	<b>182.080.11</b>
10	35	67	<b>182.100.11</b>
12	35	67	<b>182.120.11</b>
14	35	67	<b>182.140.11</b>
15	35	67	<b>182.150.11</b>
16	45	77	<b>182.160.11</b>
18	45	77	<b>182.180.11</b>
20	45	77	<b>182.200.11</b>

### TECHNICAL DETAILS:

- Super strength steel
- 2 precision ground HW cutting edges and 1 HW plunge centre tip (Z2+1)

**APPLICATION:** used for drilling, grooving and general routing operations in solid wood, wood composites, plastic and laminated materials.



HW plunge centre tip

Shank M12x1

**170** HW Z2+1

D Cutting diameter mm	I Cutting length mm	L Overall length mm	ORDER NO. Right-hand rotation
6	18	60	<b>170.060.11</b>
8	23	60	<b>170.080.11</b>
10	23	60	<b>170.100.11</b>
11	23	60	<b>170.110.11</b>
12	23	60	<b>170.120.11</b>
14	23	60	<b>170.140.11</b>
15	25	60	<b>170.150.11</b>
16	25	60	<b>170.160.11</b>
18	25	60	<b>170.180.11</b>
20	25	60	<b>170.200.11</b>
22	25	60	<b>170.220.11</b>
24	25	60	<b>170.240.11</b>
25	25	60	<b>170.250.11</b>
26	25	60	<b>170.260.11</b>
28	25	60	<b>170.280.11</b>
30	25	60	<b>170.300.11</b>
35	25	60	<b>170.350.11</b>

**TECHNICAL DETAILS:**

- Super strength steel
- 2 precision ground HW cutting edges and 1 HW plunge centre tip (Z2+1)

**APPLICATION:** used for drilling, grooving, jointing and general routing operations in solid wood, wood composites, plastic and laminated materials. Can be used on slot and mortise machines and high-speed routers equipped with chucks.

Shank M12x1

**171-180-181** HW Z2+1

D Cutting diameter mm	I Cutting length mm	L Overall length mm	ORDER NO. Right-hand rotation
8	35	67	<b>171.080.11</b>
10	35	67	<b>171.100.11</b>
11	35	67	<b>171.110.11</b>
12	35	67	<b>171.120.11</b>
14	35	67	<b>171.140.11</b>
16	35	67	<b>171.160.11</b>
18	35	67	<b>171.180.11</b>
20	35	67	<b>171.200.11</b>
22	35	67	<b>171.220.11</b>
<hr/>			
12	45	77	<b>180.120.11</b>
15	45	77	<b>180.150.11</b>
16	45	77	<b>180.160.11</b>
18	45	77	<b>180.180.11</b>
20	45	77	<b>180.200.11</b>
<hr/>			
16	60	92	<b>181.160.11</b>
20	60	92	<b>181.200.11</b>

**TECHNICAL DETAILS:**

- Super strength steel
- 2 precision ground HW cutting edges and 1 HW plunge centre tip (Z2+1)

**APPLICATION:** used for drilling, grooving, jointing and general routing operations in solid wood, wood composites, plastic and laminated materials. Can be used on slot and mortise machines and high-speed routers equipped with chucks.

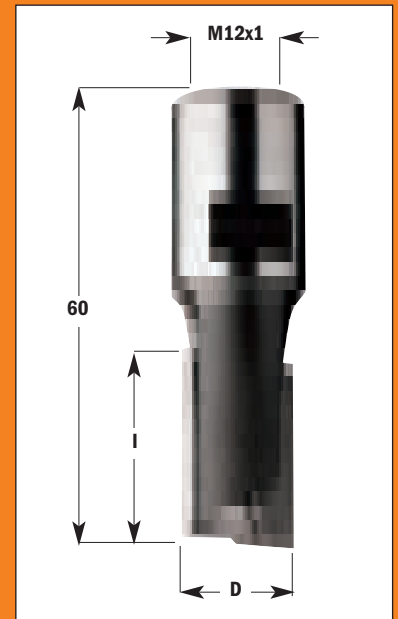

HW plunge centre tip



HW plunge centre tip

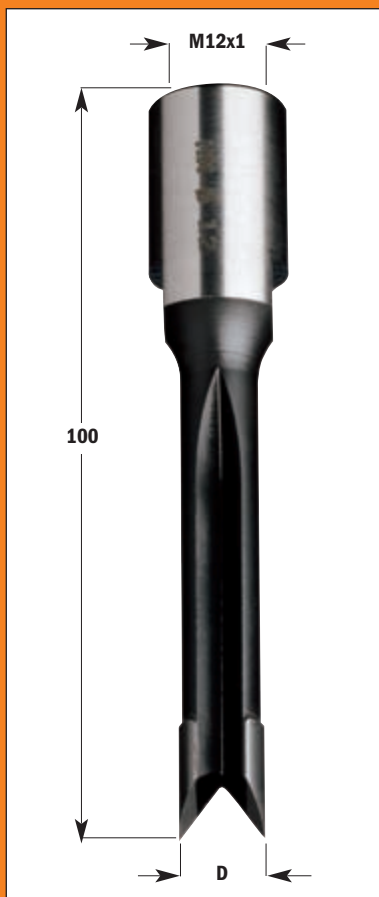

**Shank M12x1**

**163 HW Z2**

D Cutting diameter mm	L Overall length mm	ORDER NO. Right-hand rotation
12	100	<b>163.120.11</b>
14	100	<b>163.140.11</b>
16	100	<b>163.160.11</b>

**TECHNICAL DETAILS:**

- Super strength steel
- 2 precision ground HW cutting edges (Z2)

**APPLICATION HW:** used for cutting mortises and slots in solid wood and wood composites. Assembled in chucks.



**Shank M12x1**

**164 HW Z2+2**

D Cutting diameter mm	L Overall length mm	ORDER NO. Right-hand rotation
18	100	<b>164.180.11</b>
20	100	<b>164.200.11</b>
22	100	<b>164.220.11</b>

**TECHNICAL DETAILS:**

- Super strength steel
- T.C.T cutting head with precision balanced centre point
- 2 precision ground HW cutting edges (Z2)
- 2 negatively ground spurs (V2)

**APPLICATION:** used for drilling blind holes in solid wood, wood composites, plastic and laminated materials. Used on slot and mortise machines equipped with chucks.

**Shank M12x1**

**164 HL Z2+2**

D Cutting diameter mm	L Overall length mm	ORDER NO. Right-hand rotation
15	100	<b>164.150.31</b>
18	100	<b>164.180.31</b>
20	100	<b>164.200.31</b>
24	100	<b>164.240.31</b>

**TECHNICAL DETAILS:**

- Long lasting cutter performance
- SP cutting head with precision balanced centre point
- 2 precision ground edges (Z2) - 2 ground spurs (V2)

**APPLICATION:** used for drilling blind holes in soft and hard wood. Used on slot and mortise machines equipped with chucks.

**Shank M12x1**

**166-167 HW Z2+2**

d Small diameter mm	D Cutting diameter mm	ORDER NO. Right-hand rotation
11	19	<b>166.190.11</b>
11	22	<b>166.220.11</b>
12	19	<b>167.190.11</b>
12	24	<b>167.240.11</b>

**TECHNICAL DETAILS:**

- Super strength steel
- 2+2 precision ground HW cutting edges (Z2)
- 2 negatively ground spurs (V2)

**APPLICATION:** used for drilling and cutting mortise slots in solid wood, wood composites, plastic and laminated materials.

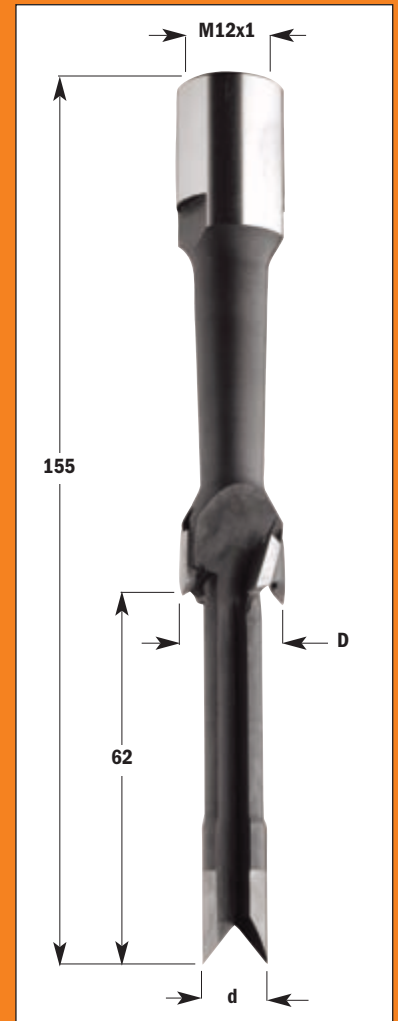

**Lockset bits**

**Shank M12x1**

**169 HL Z3**

D Cutting diameter mm	I Cutting length mm	ORDER NO. Right-hand rotation
15	22	<b>169.150.31</b>
18	22	<b>169.180.31</b>
20	22	<b>169.200.31</b>

**TECHNICAL DETAILS:**

- Long lasting cutter performance
- 3 precision ground SP cutting edges (Z3)

**APPLICATION:** used for cutting mortise slots in soft and hard wood. Used on slot and mortise machines equipped with chucks.

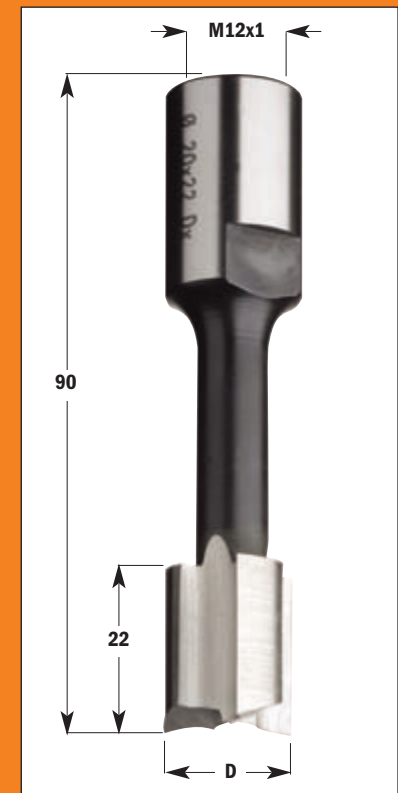



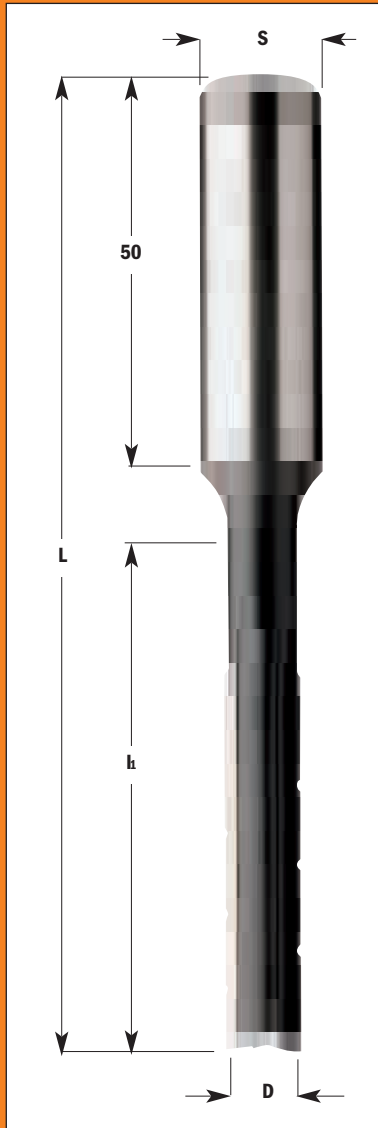

**Shank Ø16x50mm**

**102 HL Z2**

D Cutting diameter mm	l <sub>1</sub> Drilling depth mm	L Overall length mm	ORDER NO. Right-hand rotation	ORDER NO. Left-hand rotation
6	50	105	<b>102.060.31</b>	<b>102.060.32</b>
7	55	110	<b>102.070.31</b>	<b>102.070.32</b>
8	60	115	<b>102.080.31</b>	<b>102.080.32</b>
9	65	120	<b>102.090.31</b>	<b>102.090.32</b>
10	70	125	<b>102.100.31</b>	<b>102.100.32</b>
11	75	130	<b>102.110.31</b>	<b>102.110.32</b>
12	80	135	<b>102.120.31</b>	<b>102.120.32</b>
13	85	140	<b>102.130.31</b>	<b>102.130.32</b>
14	90	145	<b>102.140.31</b>	<b>102.140.32</b>
15	95	150	<b>102.150.31</b>	<b>102.150.32</b>
16	100	155	<b>102.160.31</b>	<b>102.160.32</b>
17	105	160	<b>102.170.31</b>	<b>102.170.32</b>
18	110	165	<b>102.180.31</b>	<b>102.180.32</b>
19	115	170	<b>102.190.31</b>	<b>102.190.32</b>
20	120	175	<b>102.200.31</b>	<b>102.200.32</b>
22	125	180	<b>102.220.31</b>	<b>102.220.32</b>
24	125	180	<b>102.240.31</b>	<b>102.240.32</b>

**Shank Ø13x50mm**

**172 HL Z2**

D Cutting diameter mm	l <sub>1</sub> Drilling depth mm	L Overall length mm	ORDER NO. Right-hand rotation	ORDER NO. Left-hand rotation
6	50	105	<b>172.060.31</b>	<b>172.060.32</b>
7	55	110	<b>172.070.31</b>	<b>172.070.32</b>
8	60	115	<b>172.080.31</b>	<b>172.080.32</b>
9	65	120	<b>172.090.31</b>	<b>172.090.32</b>
10	70	125	<b>172.100.31</b>	<b>172.100.32</b>
11	75	130	<b>172.110.31</b>	<b>172.110.32</b>
12	80	135	<b>172.120.31</b>	<b>172.120.32</b>
13	85	140	<b>172.130.31</b>	<b>172.130.32</b>
14	90	145	<b>172.140.31</b>	<b>172.140.32</b>
15	95	150	<b>172.150.31</b>	<b>172.150.32</b>
16	100	155	<b>172.160.31</b>	<b>172.160.32</b>
18	110	165	<b>172.180.31</b>	<b>172.180.32</b>
20	120	175	<b>172.200.31</b>	<b>172.200.32</b>

**TECHNICAL DETAILS:**

- Long lasting cutter performance
- 2 precision ground SP straight cutting edges with chip breaker teeth (Z2)

**APPLICATION:** for cutting mortise slots in soft and hard wood.  
Used on machining centres equipped with chucks.

Shank Ø16x50mm

**161** SP Z2

D Cutting diameter mm	I <sub>1</sub> Drilling depth mm	L Overall length mm	ORDER NO. Right-hand rotation	ORDER NO. Left-hand rotation
6	60	120	<b>161.060.31</b>	<b>161.060.32</b>
8	70	130	<b>161.080.31</b>	<b>161.080.32</b>
10	80	140	<b>161.100.31</b>	<b>161.100.32</b>
12	90	150	<b>161.120.31</b>	<b>161.120.32</b>
14	100	160	<b>161.140.31</b>	<b>161.140.32</b>
16	110	170	<b>161.160.31</b>	<b>161.160.32</b>

Shank Ø13x50mm

**160** SP Z2

D Cutting diameter mm	I <sub>1</sub> Drilling depth mm	L Overall length mm	ORDER NO. Right-hand rotation	ORDER NO. Left-hand rotation
6	60	120	<b>160.060.31</b>	<b>160.060.32</b>
8	70	130	<b>160.080.31</b>	<b>160.080.32</b>
10	80	140	<b>160.100.31</b>	<b>160.100.32</b>
12	90	150	<b>160.120.31</b>	<b>160.120.32</b>
14	100	160	<b>160.140.31</b>	<b>160.140.32</b>
16	110	170	<b>160.160.31</b>	<b>160.160.32</b>

**TECHNICAL DETAILS:**

- Long lasting cutter performance
- 2 precision ground SP twisted cutting edges with chip breaker teeth (Z2)

**APPLICATION:** for cutting mortise slots in soft and hard wood.  
Used on machining centres equipped with chucks.

**6 piece mortising bit set**



**102-172-160-161**

Ideal for heavy mortise jobs. Made of super strength high speed steel and available in left hand or right hand rotation. Safely packaged in a hardwood and glass box for protection, the six piece set is economical and a perfect addition to any workshop.

16mm diameter shank for series 102 and 161.

13mm diameter shank for series 172 and 160.



DESCRIPTION	ORDER NO. Right-hand rotation	ORDER NO. Left-hand rotation
6 pcs. mortising bit set, shank Ø16mm (straight)	<b>102.001.00</b>	<b>102.001.10</b>
6 pcs. mortising bit set, shank Ø13mm (straight)	<b>172.001.00</b>	<b>172.001.10</b>
6 pcs. mortising bit set, shank Ø16mm (twist)	<b>161.001.00</b>	<b>161.001.10</b>
6 pcs. mortising bit set, shank Ø13mm (twist)	<b>160.001.00</b>	<b>160.001.10</b>

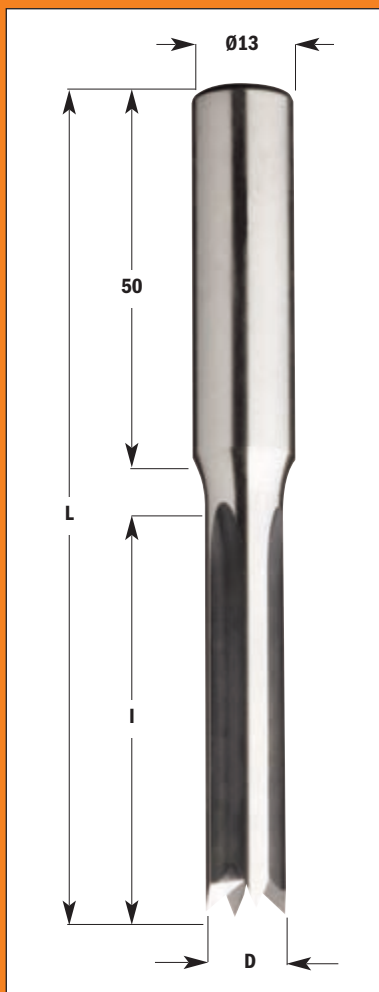

## Shank Ø13x50mm

**104** HL Z4

D Cutting diameter mm	I Cutting length mm	L Overall length mm	ORDER NO. Right-hand & Left-hand rotation
6	45	100	<b>104.060.30</b>
7	45	100	<b>104.070.30</b>
8	45	100	<b>104.080.30</b>
9	45	100	<b>104.090.30</b>
10	55	110	<b>104.100.30</b>
11	55	110	<b>104.110.30</b>
12	55	110	<b>104.120.30</b>
13	55	110	<b>104.130.30</b>
14	55	110	<b>104.140.30</b>
15	55	110	<b>104.150.30</b>
16	55	110	<b>104.160.30</b>

### TECHNICAL DETAILS:

- Long lasting cutter performance
- 4 precision ground SP cutting edges (Z4)

**APPLICATION:** used for cutting mortise slots in soft and hard wood.  
Used on machining centres equipped with chucks.

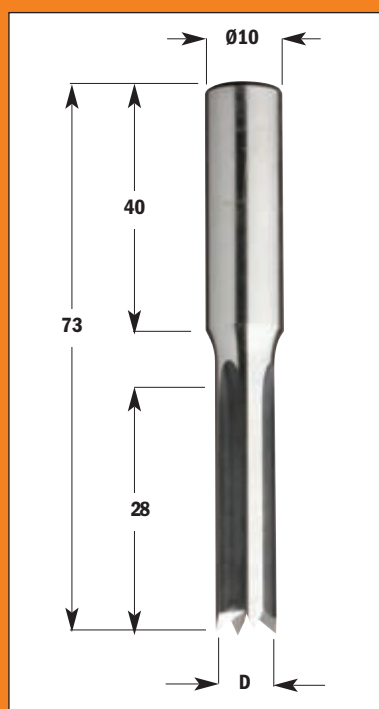

## Shank Ø10x40mm

**105** HL Z4

D Cutting diameter mm	I Cutting length mm	L Overall length mm	ORDER NO. Right-hand & Left-hand rotation
6	28	73	<b>105.060.30</b>
7	28	73	<b>105.070.30</b>
8	28	73	<b>105.080.30</b>
9	28	73	<b>105.090.30</b>
10	28	73	<b>105.100.30</b>
11	28	73	<b>105.110.30</b>
12	28	73	<b>105.120.30</b>
13	28	73	<b>105.130.30</b>
14	28	73	<b>105.140.30</b>
15	28	73	<b>105.150.30</b>
16	28	73	<b>105.160.30</b>

### TECHNICAL DETAILS:

- Long lasting cutter performance
- 4 precision ground SP cutting edges (Z4)

**APPLICATION:** used for cutting mortise slots in soft and hard wood.  
Used on machining centres equipped with chucks.

**Shank Ø16x50mm**
**103 HL Z2**

D Cutting diameter mm	I Cutting length mm	L Overall length mm	ORDER NO. Right-hand & Left-hand rotation
6	45	100	<b>103.060.30</b>
7	45	100	<b>103.070.30</b>
8	45	100	<b>103.080.30</b>
9	45	100	<b>103.090.30</b>
10	55	110	<b>103.100.30</b>
11	55	110	<b>103.110.30</b>
12	55	110	<b>103.120.30</b>
13	55	110	<b>103.130.30</b>
14	55	110	<b>103.140.30</b>
15	55	110	<b>103.150.30</b>
16	55	110	<b>103.160.30</b>

**TECHNICAL DETAILS:**

- Long lasting cutter performance
- 2 precision ground SP cutting edges (Z2)

**APPLICATION:** used for cutting mortise slots in soft and hard wood.  
Used on machining centres equipped with chucks.

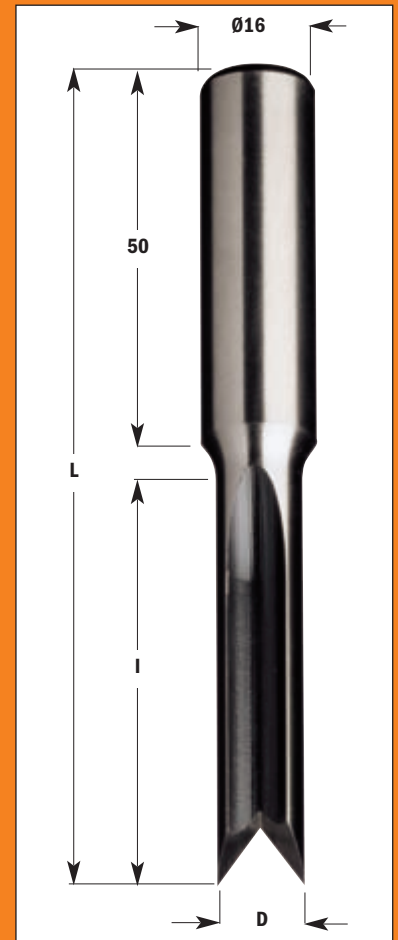

**Shank Ø13x40mm**
**179 HS Z2**

D Cutting diameter mm	I Cutting length mm	L Overall length mm	ORDER NO. Right-hand & Left-hand rotation
6	45	90	<b>179.060.50</b>
7	50	95	<b>179.070.50</b>
8	50	95	<b>179.080.50</b>
9	55	100	<b>179.090.50</b>
10	60	105	<b>179.100.50</b>
11	65	110	<b>179.110.50</b>
12	70	115	<b>179.120.50</b>
13	75	120	<b>179.130.50</b>

**TECHNICAL DETAILS:**

- Long lasting cutter performance
- 2 precision ground HS cutting edges (Z2)

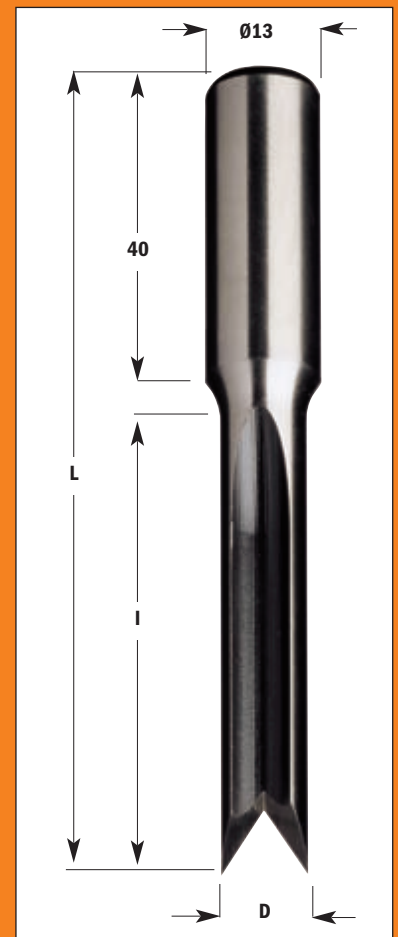
**APPLICATION:** used for cutting mortise slots in soft and hard wood.  
Used on machining centres equipped with chucks.





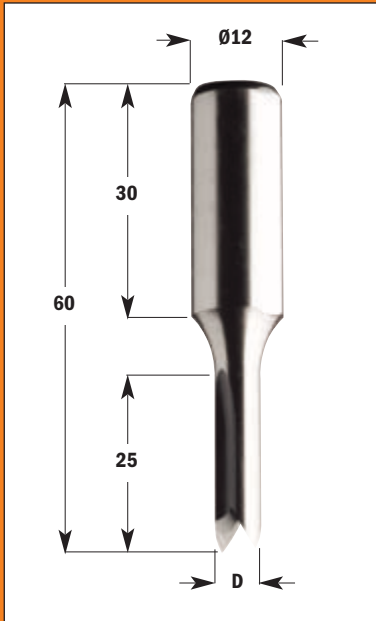

**...reciprocating slot mortising bits**

Shank Ø12x30mm

**106** HL Z2-Z4

D Cutting diameter mm	Z Number of teeth	ORDER NO. Right-hand & Left-hand rotation
6	2	<b>106.060.30</b>
7	2	<b>106.070.30</b>
8	2	<b>106.080.30</b>
9	2	<b>106.090.30</b>
10	4	<b>106.100.30</b>
11	4	<b>106.110.30</b>
12	4	<b>106.120.30</b>
13	4	<b>106.130.30</b>
14	4	<b>106.140.30</b>
15	4	<b>106.150.30</b>

**TECHNICAL DETAILS:**

- Long lasting cutter performance
- 2 or 4 precision ground SP cutting edges [Z2-Z4]

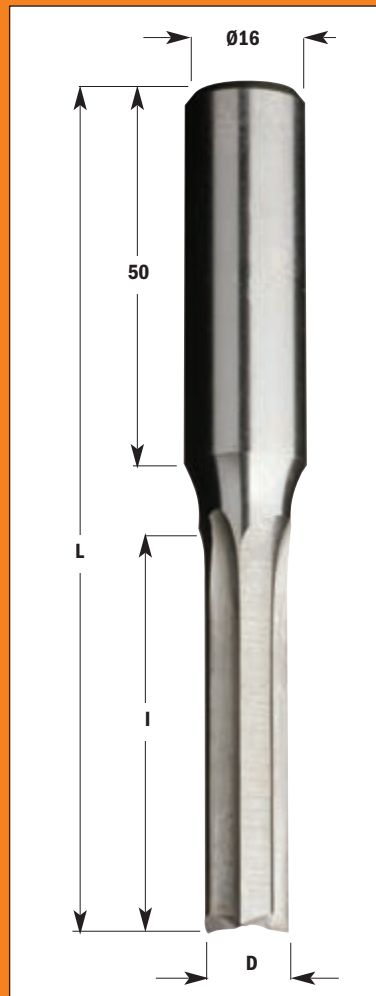

**...slot mortising bits**

Shank Ø16x50mm

**107** HL Z3

D Cutting diameter mm	I Cutting length mm	L Overall length mm	ORDER NO. Right-hand rotation	ORDER NO. Left-hand rotation
6	55	110	<b>107.060.31</b>	<b>107.060.32</b>
8	55	110	<b>107.080.31</b>	<b>107.080.32</b>
10	55	110	<b>107.100.31</b>	<b>107.100.32</b>
12	55	110	<b>107.120.31</b>	<b>107.120.32</b>
14	60	115	<b>107.140.31</b>	<b>107.140.32</b>
16	60	115	<b>107.160.31</b>	<b>107.160.32</b>
18	60	115	<b>107.180.31</b>	<b>107.180.32</b>
20	60	115	<b>107.200.31</b>	<b>107.200.32</b>

**TECHNICAL DETAILS:**

- Long lasting cutter performance
- 3 precision ground SP cutting edges (Z3)

**APPLICATION:** used for cutting mortise slots in soft and hard wood.  
Used in machining centres equipped with chucks.

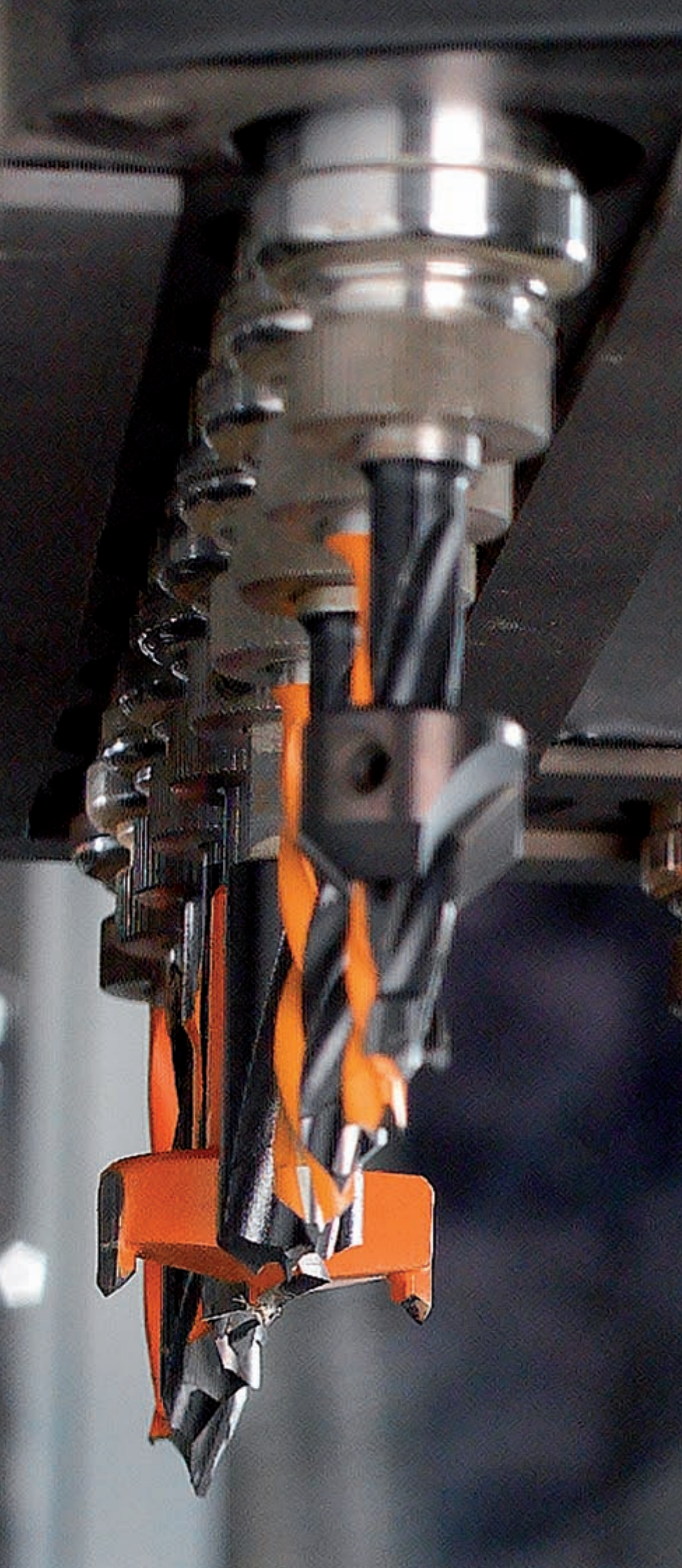

## Dowel drills



Adaptors

244



Drill holders

246



X-Treme dowel drills

248



Solid carbide twist drills

253



Dowel drills

254



Countersinks for dowel drills

260



Dowel drills for through holes

263



Hinge boring bits

264



Dowel drills with threaded shank

266

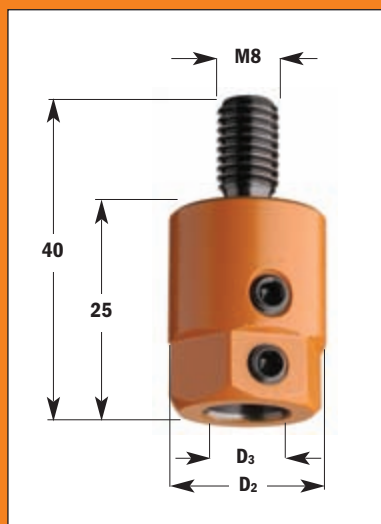

**Shank M8**

**301**

D <sub>3</sub> For shank diameter mm	D <sub>2</sub> Overall diameter mm	ORDER NO.	
		Right-hand rotation	Left-hand rotation
8	16	<b>301.080.01</b>	<b>301.080.02</b>
10	19,5	<b>301.000.01</b>	<b>301.000.02</b>

**Spare parts**

Screw M5x5	<b>990.006.00</b>
Allen key 2,5mm	<b>991.062.00</b>

**For use on the following machines:**

Nottmeyer (older models)

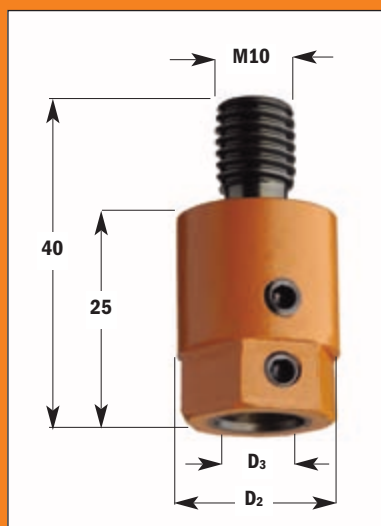

**Shank M10**

**302**

D <sub>3</sub> For shank diameter mm	D <sub>2</sub> Overall diameter mm	ORDER NO.	
		Right-hand rotation	Left-hand rotation
8	16	<b>302.080.01</b>	<b>302.080.02</b>
10	19,5	<b>302.000.01</b>	<b>302.000.02</b>

**Spare parts**

Screw M5x5	<b>990.006.00</b>
Allen key 2,5mm	<b>991.062.00</b>

**For use on the following machines:**

Ayen, Holzma, Knoevenagel, Mayer, Torwegge

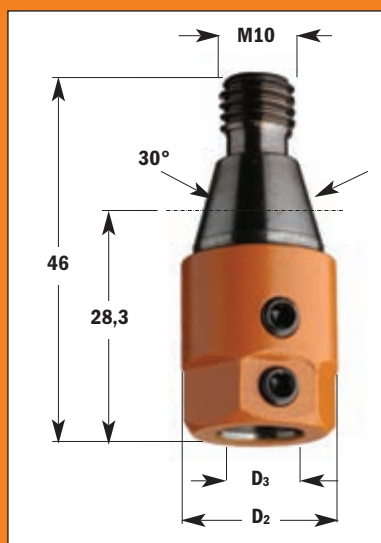

**Shank M10 with centering cone 30°**

**303**

D <sub>3</sub> For shank diameter mm	D <sub>2</sub> Overall diameter mm	ORDER NO.	
		Right-hand rotation	Left-hand rotation
8	16	<b>303.080.01</b>	<b>303.080.02</b>
10	19,5	<b>303.000.01</b>	<b>303.000.02</b>

**Spare parts**

Screw M5x5	<b>990.006.00</b>
Allen key 2,5mm	<b>991.062.00</b>

**For use on the following machines:**

Alberti (older models)  
Balestrini, Bilek, Busellato (older models)  
Schleicher, Vitap (older models)

**TECHNICAL DETAILS:**

- High precision - total reliability
- Perfectly centred
- Rotation defect-free
- Super-strength steel
- Precision relief on all surfaces
- Quick drill change
- Adaptable to a variety of different spindle nose designs



**Shank M8 with centering cone 20°48'**
**304**

D <sub>3</sub> For shank diameter mm	D <sub>2</sub> Overall diameter mm	ORDER NO. Right-hand rotation	ORDER NO. Left-hand rotation
8	16	<b>304.080.01</b>	<b>304.080.02</b>
10	19,5	<b>304.000.01</b>	<b>304.000.02</b>

**Spare parts**

Screw M5x5	<b>990.006.00</b>
Allen key 2,5mm	<b>991.062.00</b>

**For use on the following machines:**

Balestrini, Bilek

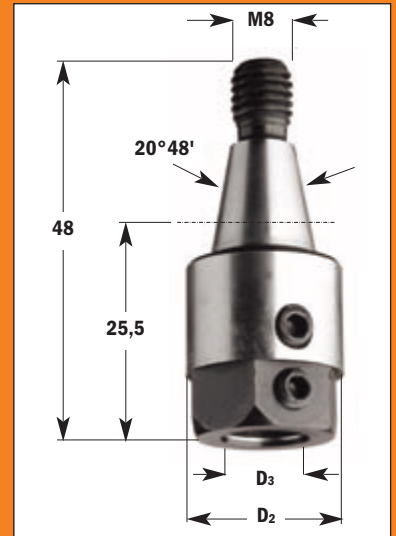

**Shank M10 with seating Ø11x4mm**
**305**

D <sub>3</sub> For shank diameter mm	D <sub>2</sub> Overall diameter mm	ORDER NO. Right-hand rotation	ORDER NO. Left-hand rotation
8	16	<b>305.080.01</b>	<b>305.080.02</b>
10	19,5	<b>305.000.01</b>	<b>305.000.02</b>

**Spare parts**

Screw M5x5	<b>990.006.00</b>
Allen key 2,5mm	<b>991.062.00</b>

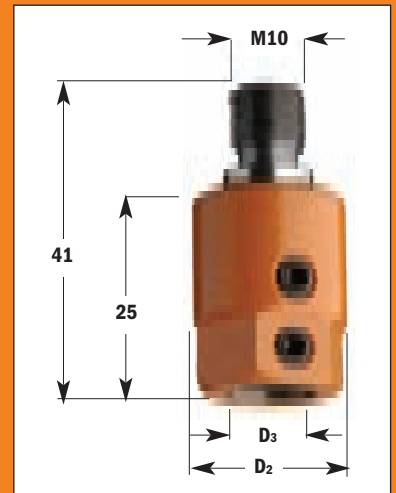
**For use on the following machines:**

 Biesse (older models)  
 Masterwood (Zangheri & Boschetti)  
 Morbidelli, Torwegge, Vitap (new design)  
 Weeke

**Shank M8 with seating Ø9x4mm**
**358**

D <sub>3</sub> For shank diameter mm	D <sub>2</sub> Overall diameter mm	ORDER NO. Right-hand rotation	ORDER NO. Left-hand rotation
8	16	<b>358.080.01</b>	<b>358.080.02</b>
10	19,5	<b>358.000.01</b>	<b>358.000.02</b>

**Spare parts**

Screw M5x5	<b>990.006.00</b>
Allen key 2,5mm	<b>991.062.00</b>

**For use on the following machines:**

 Masterwood (Zangheri & Boschetti)  
 Morbidelli, Nottmeyer (new design)

**TECHNICAL DETAILS:**

- High precision - total reliability
- Perfectly centred
- Rotation defect-free
- Super-strength steel
- Precision relief on all surfaces
- Quick drill change
- Adaptable to a variety of different spindle nose designs

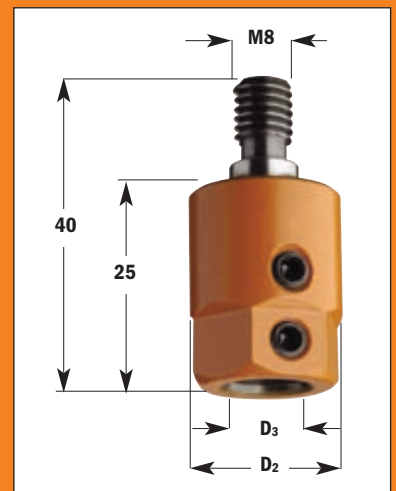





**Shank M10**

**359**

D <sub>3</sub> For shank diameter mm	D <sub>2</sub> Overall diameter mm	ORDER NO. Right-hand rotation	ORDER NO. Left-hand rotation
10	19,5	<b>359.000.01</b>	<b>359.000.02</b>

**Spare parts**

Screw M5x5	<b>990.006.00</b>
Allen key 2,5mm	<b>991.062.00</b>

**For use on the following machines:**

Scheer

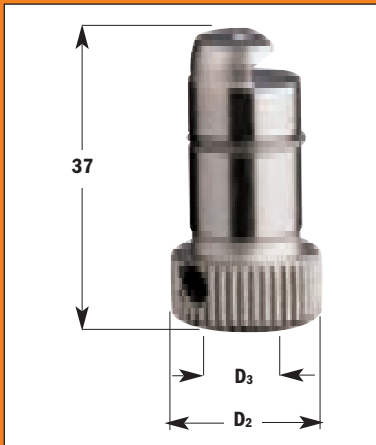

**Drill holder for Biesse machines**

**360.001**

D <sub>3</sub> For shank diameter mm	D <sub>2</sub> Overall diameter mm	ORDER NO. Right-hand rotation	ORDER NO. Left-hand rotation
10	20	<b>360.001.01</b>	<b>360.001.02</b>

**Spare parts**

Screw M6x6	<b>990.007.00</b>
Allen key 3mm	<b>991.322.00</b>

**For use on the following machines:**

For Biesse machines with quick drill change attachment



**Drill holder for Vitap machines**

**360.101**

D <sub>3</sub> For shank diameter mm	D <sub>2</sub> Overall diameter mm	ORDER NO. Right-hand & Left-hand rotation
10	18	<b>360.101.00</b>

**Spare parts**

Screw M5x4	<b>990.015.00</b>
Allen key 2,5mm	<b>991.062.00</b>

**For use on the following machines:**

Vitap (APA70)

**TECHNICAL DETAILS:**

- High precision - total reliability
- Perfectly centred
- Rotation defect-free
- Super-strength steel
- Precision relief on all surfaces
- Quick drill change
- Adaptable to a variety of different spindle nose designs



# XTRME BORING BITS

SETTING A NEW STANDARD FOR PERFORMANCE AND VALUE

## NEW DOWN CUT ROUND SHARPENING

Angle edge

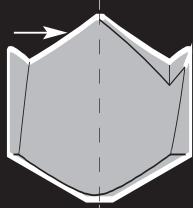

## EXTRA-FINE MICROGRAIN CARBIDE

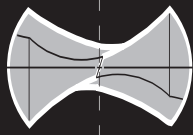

Reduced boring surface enabling  
faster feed speed

## STANDARD SHARPENING

Flat edge

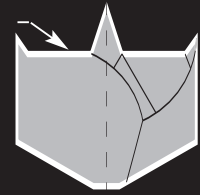

## STANDARD CARBIDE

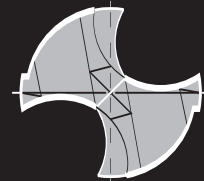

Standard boring surface

## Finest Industrial Quality Micrograin Carbide

CMT puts the finest quality at the cutting edge. Produced by Luxembourg's Cerametal, CMT's carbide tips are selected from carbide grades which hold an edge longer and improve durability and impact resistance.

## PT.FE. Coating

Our PTFE coating provides a non-stick surface that prevents residue accumulation on the bit. Baked on at 420° C, this unique, industrial strength material is specifically designed to meet the requirements of woodworking tools.

## High-Strength Steel Body

The shanks and bodies of all our bits are machined from solid bar stock steel made by Von Moos Steel in Switzerland. The primary mechanical properties are:

- superior strength
- high level uniformity
- minimal distortion
- exceptional resistance to fatigue and abrasion

## Micrograin Carbide Sharpening

The sharpening on the carbide cutting edge provides a 0.4µ/mm. micrograin finish. This is done on automated CNC machines that are equipped with as many as 6 axes for maximum accuracy.

## Special metal shock resistant brazing

Micrograin carbide tips are applied with a special brazing compound. This allows a higher brazing temperature than other methods, and guarantees a solid bond of every tip on every bit.

## Steel shank grinding

CMT grinds the steel shank to a micrograin finish of 0.8µ/mm. The smooth finish on the shank determines how well the drill fits into your machine. A rough grind results in a poor grip by the chuck and wobbly rotation.



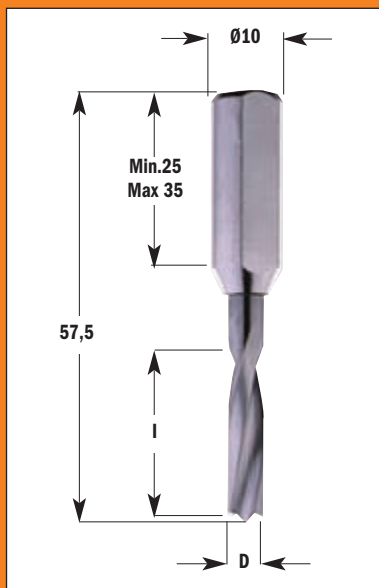

### Shank Ø10mm

### 310.21/22 HWM

D Cutting diameter mm	I Cutting length mm	S Shank diameter mm	ORDER NO.	
			Right-hand rotation	Left-hand rotation
3	9	10x35	<b>310.530.21</b>	<b>310.530.22</b>
3	18	10x25	<b>310.030.21</b>	<b>310.030.22</b>
4	20	10x25	<b>310.040.21</b>	<b>310.040.22</b>
5	22	10x25	<b>310.050.21</b>	<b>310.050.22</b>
6	22	10x25	<b>310.060.21</b>	<b>310.060.22</b>
6,35 (1/4")	22	10x25	<b>310.064.21</b>	<b>310.064.22</b>

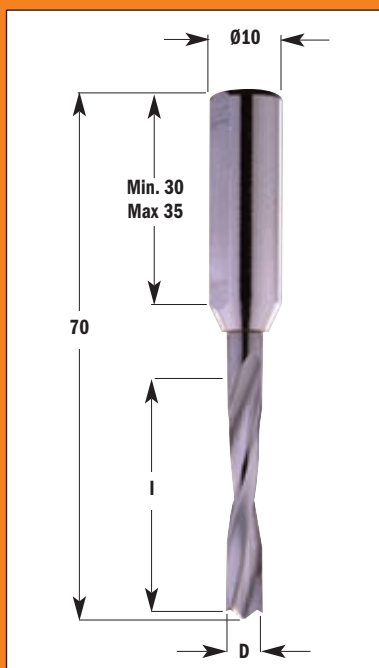

### Shank Ø10mm

### 311.21/22 HWM

D Cutting diameter mm	I Cutting length mm	S Shank diameter mm	ORDER NO.	
			Right-hand rotation	Left-hand rotation
3	18	10x35	<b>311.030.21</b>	<b>311.030.22</b>
4	27	10x30	<b>311.040.21</b>	<b>311.040.22</b>
5	30	10x30	<b>311.050.21</b>	<b>311.050.22</b>
6	30	10x30	<b>311.060.21</b>	<b>311.060.22</b>
6,35 (1/4")	30	10x30	<b>311.064.21</b>	<b>311.064.22</b>

### Spare parts

Screw M5x10	<b>990.003.00</b>
-------------	-------------------

### TECHNICAL DETAILS:

- Premium quality super-strength steel
- HWM spiral portion with centre point
- 2 cutting edges (Z2)
- 2 spiral flutes
- 2 curved, negatively ground spurs (V2)
- Parallel shank with driving flat and adjustable screw length.

**APPLICATION:** used on boring machines alone or with chucks for drilling blind holes in solid wood, wood composites, plastic and laminated materials.

### Perfect for all materials and long lasting performance

CMT announces the new series of solid carbide boring bits, now available from their extensive industrial line. These bits are entirely made of premium quality super micrograin carbide from Ceratizit in Luxembourg. The entire series offers several design features:

- The unique tip has curved, negatively ground spurs to produce exceptionally clean bores with no rough edges. Centre point balanced.
- The cylindrical head is bigger than traditional tips and is extremely resistant to prolonged use. Lasts longer between sharpenings.
- The plunge edge runs all the way to the centre of the bit to reduce drilling resistance and increase production speed.
- The solid carbide construction guarantees an almost infinite number of sharpenings, and because it is a solid unit of carbide, it offers an extra safety feature.
- Ideal for hard woods and difficult composites such as particle board, MDF and veneer.
- Excellent performance on high-speed boring units and CNC routers.

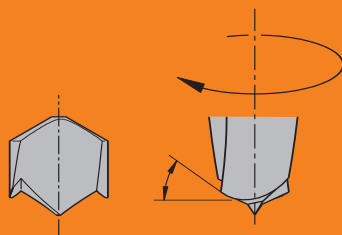

**Xtreme sharpening**

Shank Ø10x27mm

**310.41/42 HW**

D Cutting diameter mm	I Cutting length mm	L Overall length mm	ORDER NO.	
			Right-hand rotation	Left-hand rotation
5	27	57,5	<b>310.050.41</b>	<b>310.050.42</b>
6	27	57,5	<b>310.060.41</b>	<b>310.060.42</b>
7	27	57,5	<b>310.070.41</b>	<b>310.070.42</b>
8	27	57,5	<b>310.080.41</b>	<b>310.080.42</b>
9	27	57,5	<b>310.090.41</b>	<b>310.090.42</b>
10	27	57,5	<b>310.100.41</b>	<b>310.100.42</b>

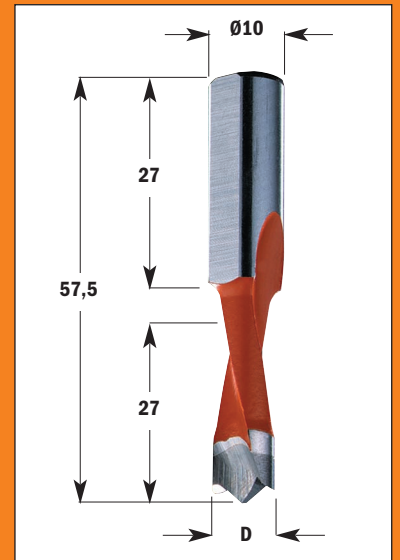

Shank Ø10x30mm

**311.41/42 HW**

D Cutting diameter mm	I Cutting length mm	L Overall length mm	ORDER NO.	
			Right-hand rotation	Left-hand rotation
5	35	70	<b>311.050.41</b>	<b>311.050.42</b>
6	35	70	<b>311.060.41</b>	<b>311.060.42</b>
7	35	70	<b>311.070.41</b>	<b>311.070.42</b>
8	35	70	<b>311.080.41</b>	<b>311.080.42</b>
9	35	70	<b>311.090.41</b>	<b>311.090.42</b>
10	35	70	<b>311.100.41</b>	<b>311.100.42</b>

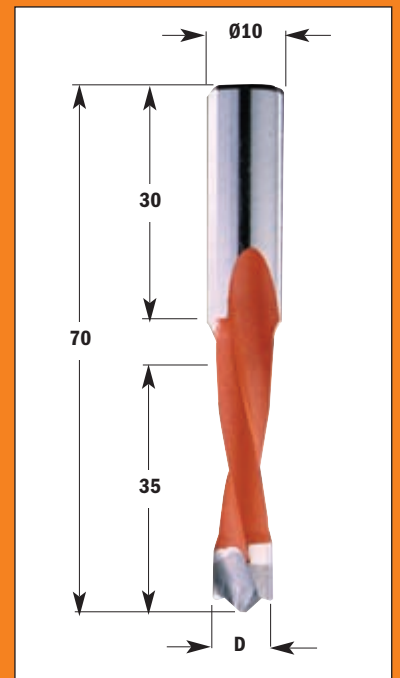

Spare parts

Screw M5x10	<b>990.003.00</b>
-------------	-------------------

TECHNICAL DETAILS:

- Premium quality super-strength steel
- Spiral portion coated with orange or black P.T.F.E.
- Extra-fine micrograin carbide spiral portion with centre point
- 2 cutting edges (Z2)
- 2 spiral flutes
- 2 curved, negatively ground spurs (V2)
- Parallel shank with driving flat and adjustable screw length.

**APPLICATION:** used on boring machines alone or with chucks for drilling blind holes in solid wood, wood composites, plastic and laminated materials.

**Perfect for all materials and long lasting performance**

CMT announces the new extra-fine micrograin carbide dowel drills series, now available from their extensive industrial line. These bits are entirely made of premium quality extra-fine micrograin carbide from Ceratizit in Luxembourg. The entire series offers several design features:

- The unique tip has curved, negatively ground spurs to produce exceptionally clean bores with no rough edges. Centre point balanced.
- The cylindrical head is bigger than traditional tips and is extremely resistant to prolonged use. Lasts longer between sharpenings.
- The plunge edge runs all the way to the centre of the bit to reduce drilling resistance and increase production speed.
- Ideal for hard woods and difficult composites such as particle board, MDF and veneer.
- Excellent performance on high-speed boring units and CNC routers.

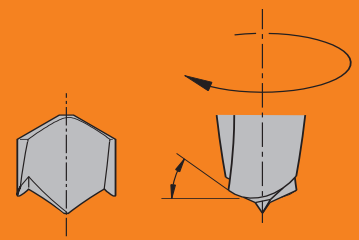

**Xtreme sharpening**



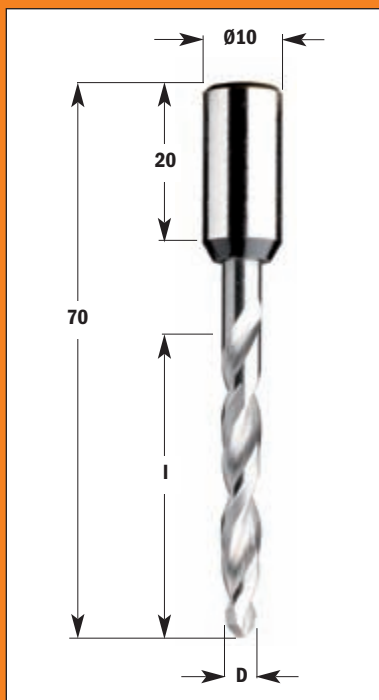

### Shank Ø10x20mm

### 314.21/22 HWM

D Cutting diameter mm	I Cutting length mm	L Overall length mm	ORDER NO. Right-hand rotation	ORDER NO. Left-hand rotation
4	40	70	314.040.21	314.040.22
5	40	70	314.050.21	314.050.22
6	40	70	314.060.21	314.060.22
8	40	70	314.080.21	314.080.22

### Spare parts

Screw M5x8	990.008.00
------------	------------

For panels with a 25-30mm maximum thickness

### TECHNICAL DETAILS:

- Premium quality super-strength steel
- HWM spiral portion with centre point
- 2 precision ground cutting edges (Z2)
- 2 spiral flutes
- Parallel shank with driving flat and adjustable screw length.

**APPLICATION:** used on boring machines and dowel drilling devices.

Use for drilling through holes in solid wood, wood composites, plastic and laminated materials

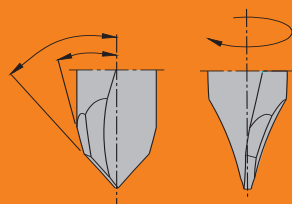

XTreme sharpening

## Grinding wheels for XTreme sharpening

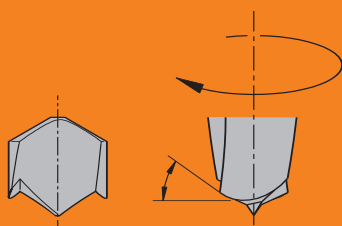
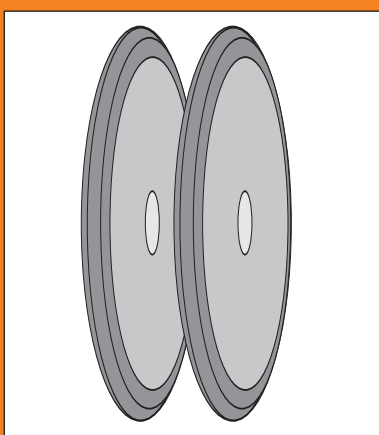

XTreme sharpening

### 01.02

D Cutting diameter mm	DESCRIPTION	Dimension mm	Bore mm	ORDER NO.
Ø3 to 7	Grinding wheel for re-sharpening	Ø125x5,5	Ø20	01.02.0316
Ø8 to 10	Grinding wheel for re-sharpening	Ø125x7	Ø20	01.02.0317

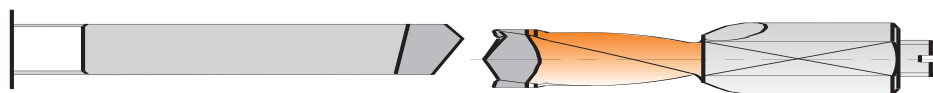

Shank Ø10x26mm

**313.41/42** HW

D Cutting diameter mm	I Cutting length mm	L Overall length mm	ORDER NO. Right-hand rotation	ORDER NO. Left-hand rotation
5	27	57,5	<b>313.050.41</b>	<b>313.050.42</b>
8	27	57,5	<b>313.080.41</b>	<b>313.080.42</b>

For panels with a 20mm maximum thickness

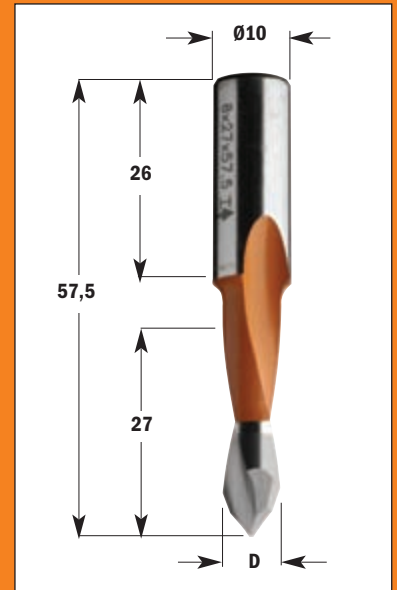

Shank Ø10x26mm

**314.41/42** HW

D Cutting diameter mm	I Cutting length mm	L Overall length mm	ORDER NO. Right-hand rotation	ORDER NO. Left-hand rotation
5	35	70	<b>314.050.41</b>	<b>314.050.42</b>
8	35	70	<b>314.080.41</b>	<b>314.080.42</b>

**Spare parts**

Screw M5x10	<b>990.003.00</b>
-------------	-------------------

For panels with a 30mm maximum thickness

**TECHNICAL DETAILS:**

- Super-strength steel
- Spiral portion coated with orange or black P.T.F.E.
- Extra-fine micrograin carbide spiral portion with centre point
- HW head with precision balanced centre point
- 2 precision ground cutting edges (Z2)
- 2 spiral flutes
- Parallel shank with driving flat and length adjusting screw.

**APPLICATION:** used on boring machines and dowel drilling devices. Use for drilling through holes in solid wood, wood composites, plastic and laminated materials.

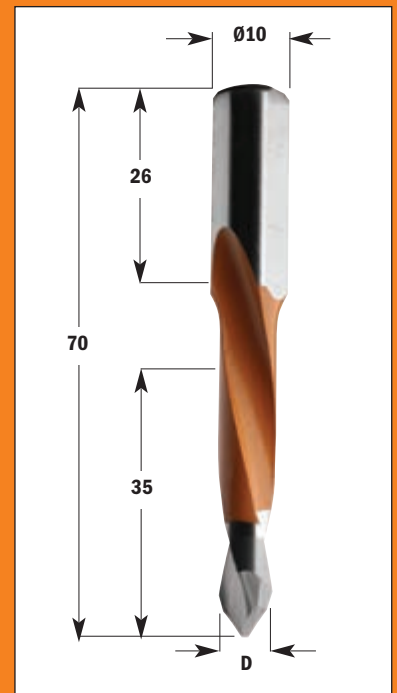

**Perfect for all materials and long lasting performance**

CMT announces the new extra-fine micrograin carbide dowel drills series, now available from their extensive industrial line. These bits are entirely made of premium quality extra-fine micrograin carbide from Ceratizit in Luxembourg. The entire series offers several design features:

- The unique tip has curved, negatively ground spurs to produce exceptionally clean bores with no rough edges. Centre point balanced.
- The cylindrical head is bigger than traditional tips and is extremely resistant to prolonged use. Lasts longer between sharpenings.
- The plunge edge runs all the way to the centre of the bit to reduce drilling resistance and increase production speed.
- Ideal for hard woods and difficult composites such as particle board, MDF and veneer.
- Excellent performance on high-speed boring units and CNC routers.

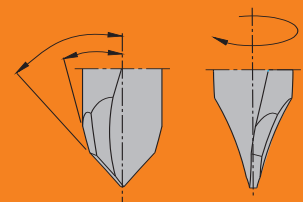

**Xtreme sharpening**

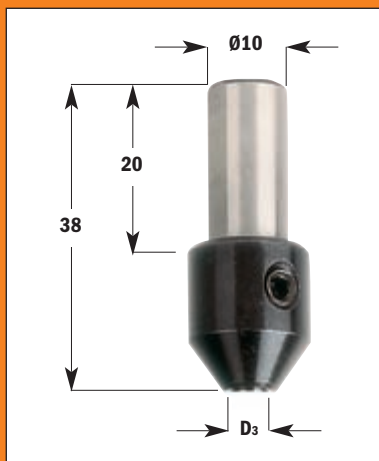

**364**

**Shank Ø10x20mm**

D <sub>3</sub> For shank diameter mm	L Overall length mm	ORDER NO.
2	38	364.020.00
2,5	38	364.025.00
3	38	364.030.00
3,2	38	364.032.00
3,5	38	364.035.00
4	38	364.040.00
4,5	38	364.045.00
5	38	364.050.00

**Spare parts**

Screw M5x5	990.001.00
Allen key 2,5mm	991.062.00

To use with the following items: 363 HW

**TECHNICAL DETAILS:**

- Super-strength steel
- Quick and secure assembly on twist drills
- Precision relief
- Parallel shank with driving flat and length adjusting screw

**APPLICATION:** for use with twist drills with common shank and bushing diameter. Used on boring machines equipped with adaptor chucks.

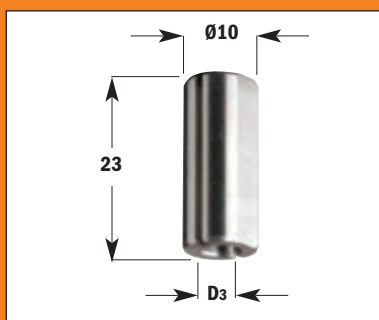

**365**

**Shank Ø10x23mm**

D <sub>3</sub> For shank diameter mm	L Overall length mm	ORDER NO.
2	23	365.020.00
2,5	23	365.025.00
3	23	365.030.00
3,2	23	365.032.00
3,5	23	365.035.00
4	23	365.040.00
4,5	23	365.045.00
5	23	365.050.00

To use with the following items: 363 HW

**TECHNICAL DETAILS:**

- Super-strength steel
- Shank with driving flat
- Axial cuttings for cylindrical drill clamps

**APPLICATION:** used with spiral boring bits with shank diameters equal to the bushing diameter. Used on boring machines equipped with adaptors.

... "V" point 120° sharpening

**363 HWM**

S=D Cutting diameter mm	I Cutting length mm	L Overall length mm	ORDER NO. Right-hand rotation	ORDER NO. Left-hand rotation
2	25	50	<b>363.020.11</b>	<b>363.020.12</b>
2,5	27	55	<b>363.025.11</b>	<b>363.025.12</b>
3	27	55	<b>363.030.11</b>	<b>363.030.12</b>
3,2	27	52	<b>363.032.11</b>	<b>363.032.12</b>
3,5	27	52	<b>363.035.11</b>	<b>363.035.12</b>
4	27	55	<b>363.040.11</b>	<b>363.040.12</b>
4,5	28	60	<b>363.045.11</b>	<b>363.045.12</b>
5	28	60	<b>363.050.11</b>	<b>363.050.12</b>

To use with the following items: 364-365

**TECHNICAL DETAILS:**

- Premium quality HWM
- 2 precision ground cutting edges (Z2)
- 2 spiral flutes
- Common shank and drilling diameter (S=D)

**APPLICATION:** used in adapter bushings.

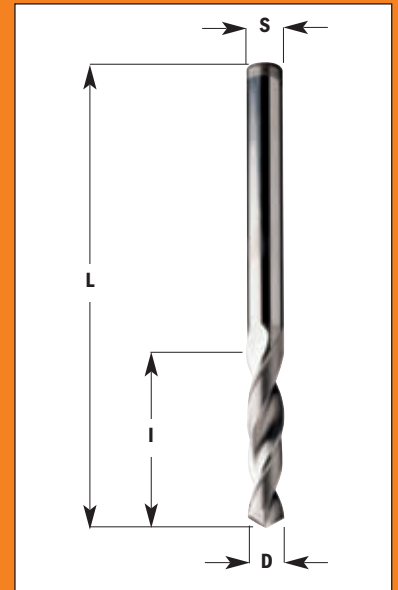

Negatively ground spurs sharpening

**363 HWM**

S=D Cutting diameter mm	I Cutting length mm	L Overall length mm	ORDER NO. Right-hand rotation	ORDER NO. Left-hand rotation
2,5	27	55	<b>363.025.21</b>	<b>363.025.22</b>
3	27	55	<b>363.030.21</b>	<b>363.030.22</b>
4	27	55	<b>363.040.21</b>	<b>363.040.22</b>
5	28	60	<b>363.050.21</b>	<b>363.050.22</b>

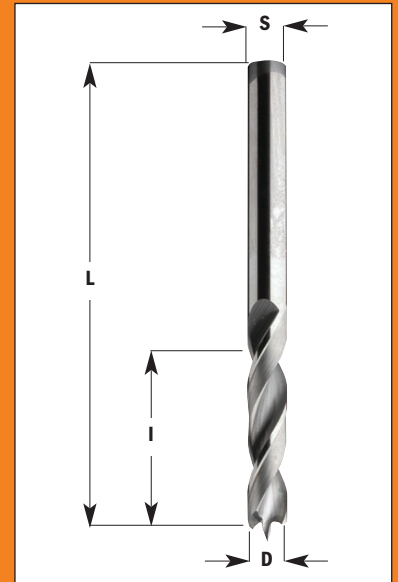

Assembly Illustration

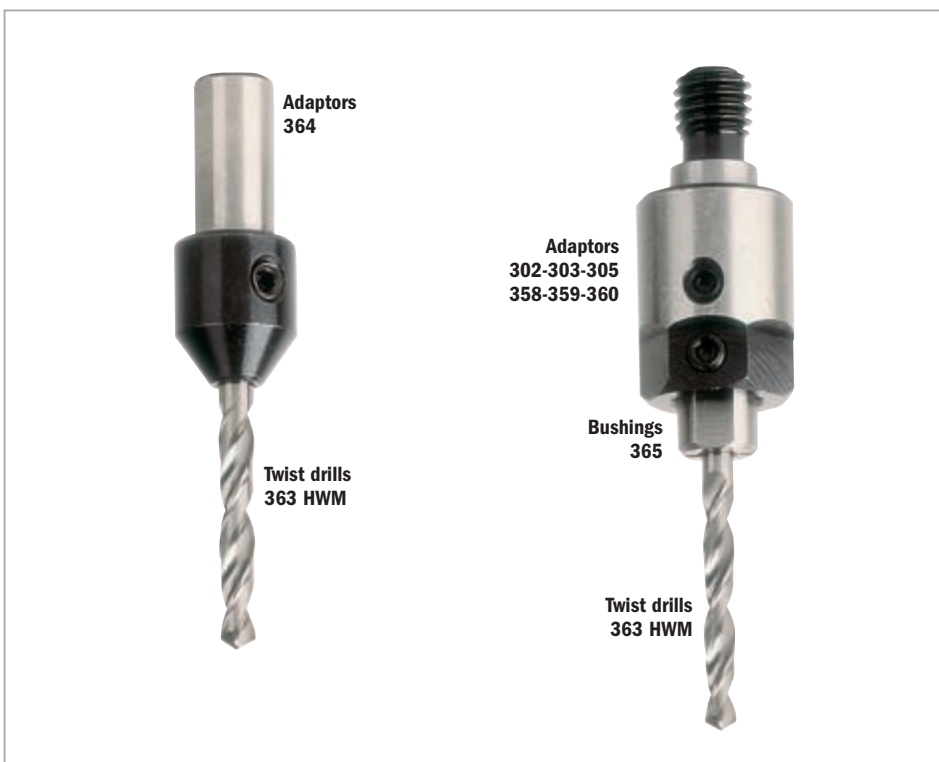



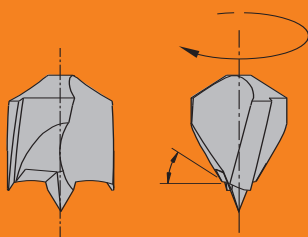
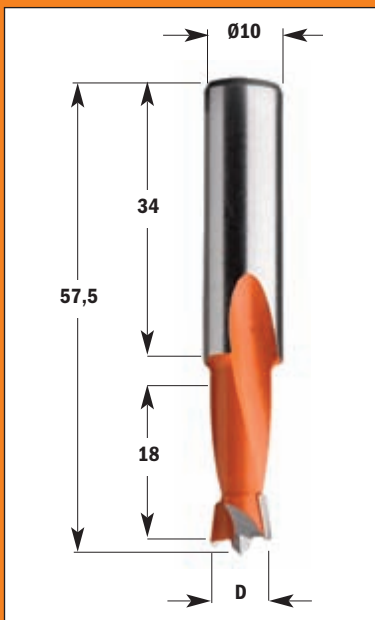
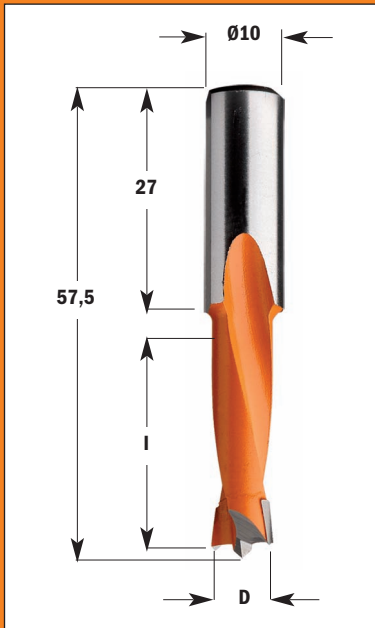

Negatively ground spurs

**Shank Ø10x27mm**

**310 HW**

D Cutting diameter		I Cutting length	L Overall length	ORDER NO. Right-hand rotation	ORDER NO. Left-hand rotation
mm	inches	mm	mm		
4	5/32	18	57,5	<b>310.040.11</b>	<b>310.040.12</b>
4,5		22	57,5	<b>310.045.11</b>	<b>310.045.12</b>
4,76	3/16	27	57,5	<b>310.047.11</b>	<b>310.047.12</b>
5		27	57,5	<b>310.050.11</b>	<b>310.050.12</b>
5,1		27	57,5	<b>310.051.11</b>	<b>310.051.12</b>
5,2		27	57,5	<b>310.052.11</b>	<b>310.052.12</b>
5,55	7/32	27	57,5	<b>310.055.11</b>	<b>310.055.12</b>
6		27	57,5	<b>310.060.11</b>	<b>310.060.12</b>
6,35	1/4	27	57,5	<b>310.064.11</b>	<b>310.064.12</b>
6,5		27	57,5	<b>310.065.11</b>	<b>310.065.12</b>
7		27	57,5	<b>310.070.11</b>	<b>310.070.12</b>
8		27	57,5	<b>310.080.11</b>	<b>310.080.12</b>
8,2		27	57,5	<b>310.082.11</b>	<b>310.082.12</b>
9		27	57,5	<b>310.090.11</b>	<b>310.090.12</b>
9,52	3/8	27	57,5	<b>310.095.11</b>	<b>310.095.12</b>
10		27	57,5	<b>310.100.11</b>	<b>310.100.12</b>
11		27	57,5	<b>310.110.11</b>	<b>310.110.12</b>
12		27	57,5	<b>310.120.11</b>	<b>310.120.12</b>
12,7	1/2	27	57,5	<b>310.127.11</b>	<b>310.127.12</b>
13		27	57,5	<b>310.130.11</b>	<b>310.130.12</b>
14		27	57,5	<b>310.140.11</b>	<b>310.140.12</b>
15		27	57,5	<b>310.150.11</b>	<b>310.150.12</b>
16		27	57,5	<b>310.160.11</b>	<b>310.160.12</b>
<b>NEW</b> 50 pcs. in masterpack				<b>310.050.11-X50</b>	<b>310.050.12-X50</b>

**Shank Ø10x34mm**

**361 HW**

D Cutting diameter		I Cutting length	L Overall length	ORDER NO. Right-hand rotation	ORDER NO. Left-hand rotation
mm		mm	mm		
5		18	57,5	<b>361.050.11</b>	<b>361.050.12</b>
6		18	57,5	<b>361.060.11</b>	<b>361.060.12</b>
7		18	57,5	<b>361.070.11</b>	<b>361.070.12</b>
8		18	57,5	<b>361.080.11</b>	<b>361.080.12</b>
10		18	57,5	<b>361.100.11</b>	<b>361.100.12</b>

**Spare parts**

Screw M5x10	<b>990.003.00</b>
-------------	-------------------

**TECHNICAL DETAILS:**

- Super-strength steel
- Spiral portion coated with orange or black P.T.F.E.
- HW head with precision balanced centre point
- 2 precision ground HW cutting edges (Z2)
- 2 negatively ground spurs (V2)
- 2 spiral flutes
- Parallel shank with driving flat and length adjusting screw.

**APPLICATION:** used on boring machines equipped with adaptors or chucks.  
Used to drill blind holes in solid wood, wood composites, plastic and laminated materials.

Shank Ø10x30mm

**311 HW**

D Cutting diameter		I Cutting length mm	L Overall length mm	ORDER NO.	ORDER NO.
mm	inches			Right-hand rotation	Left-hand rotation
4	5/32	26	70	<b>311.040.11</b>	<b>311.040.12</b>
4,5		35	70	<b>311.045.11</b>	<b>311.045.12</b>
4,76	3/16	35	70	<b>311.047.11</b>	<b>311.047.12</b>
5		35	70	<b>311.050.11</b>	<b>311.050.12</b>
5,1		35	70	<b>311.051.11</b>	<b>311.051.12</b>
5,2		35	70	<b>311.052.11</b>	<b>311.052.12</b>
5,55	7/32	35	70	<b>311.055.11</b>	<b>311.055.12</b>
6		35	70	<b>311.060.11</b>	<b>311.060.12</b>
6,35	1/4	35	70	<b>311.064.11</b>	<b>311.064.12</b>
6,5		35	70	<b>311.065.11</b>	<b>311.065.12</b>
7		35	70	<b>311.070.11</b>	<b>311.070.12</b>
8		35	70	<b>311.080.11</b>	<b>311.080.12</b>
8,2		35	70	<b>311.082.11</b>	<b>311.082.12</b>
9		35	70	<b>311.090.11</b>	<b>311.090.12</b>
9,52	3/8	35	70	<b>311.095.11</b>	<b>311.095.12</b>
10		35	70	<b>311.100.11</b>	<b>311.100.12</b>
11		35	70	<b>311.110.11</b>	<b>311.110.12</b>
11,1	7/16	35	70	<b>311.111.11</b>	<b>311.111.12</b>
12		35	70	<b>311.120.11</b>	<b>311.120.12</b>
12,7	1/2	35	70	<b>311.127.11</b>	<b>311.127.12</b>
13		35	70	<b>311.130.11</b>	<b>311.130.12</b>
14		35	70	<b>311.140.11</b>	<b>311.140.12</b>
15		35	70	<b>311.150.11</b>	<b>311.150.12</b>
16		35	70	<b>311.160.11</b>	<b>311.160.12</b>

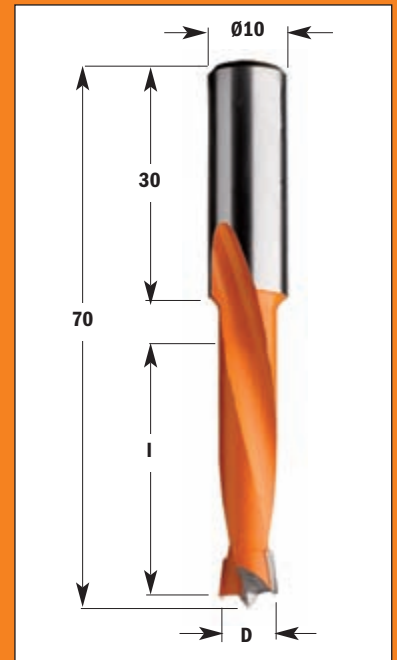

Shank Ø10x30mm

**362 HW**

D Cutting diameter		I Cutting length mm	L Overall length mm	ORDER NO.	ORDER NO.
mm				Right-hand rotation	Left-hand rotation
5		44	77	<b>362.050.11</b>	<b>362.050.12</b>
6		44	77	<b>362.060.11</b>	<b>362.060.12</b>
7		44	77	<b>362.070.11</b>	<b>362.070.12</b>
8		44	77	<b>362.080.11</b>	<b>362.080.12</b>
10		44	77	<b>362.100.11</b>	<b>362.100.12</b>
12		44	77	<b>362.120.11</b>	<b>362.120.12</b>

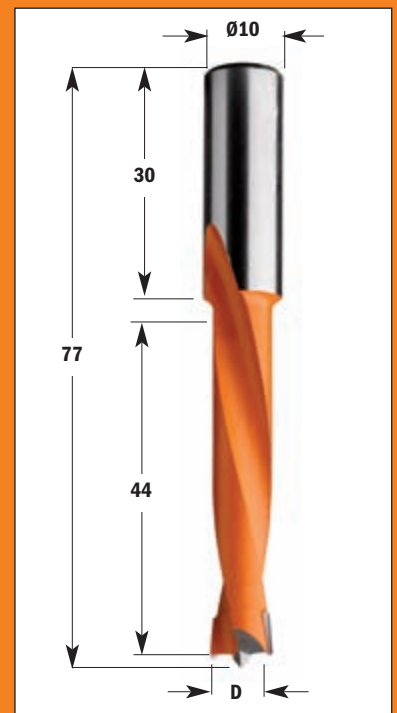

Spare parts

Screw M5x10	<b>990.003.00</b>
-------------	-------------------

TECHNICAL DETAILS:

- Super-strength steel
- Spiral portion coated with orange or black P.T.F.E.
- HW head with precision balanced centre point
- 2 precision ground HW cutting edges (Z2)
- 2 negatively ground spurs (V2)
- 2 spiral flutes
- Parallel shank with driving flat and length adjusting screw.

**APPLICATION:** used on boring machines equipped with adaptors or chucks.  
Used to drill blind holes in solid wood, wood composites, plastic and laminated materials.

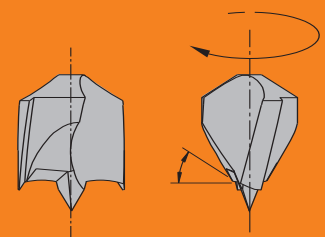

Negatively ground spurs

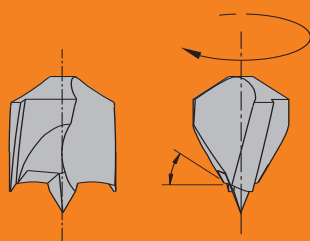
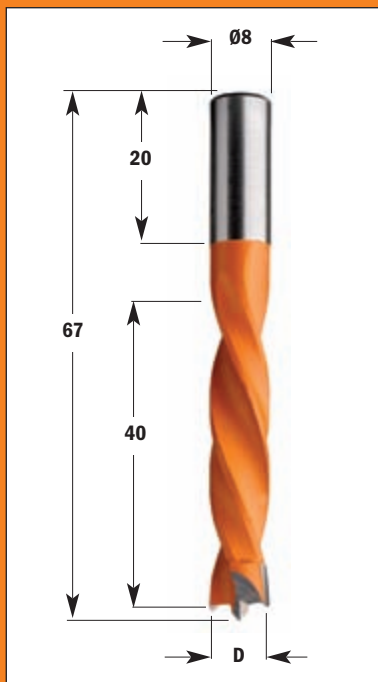
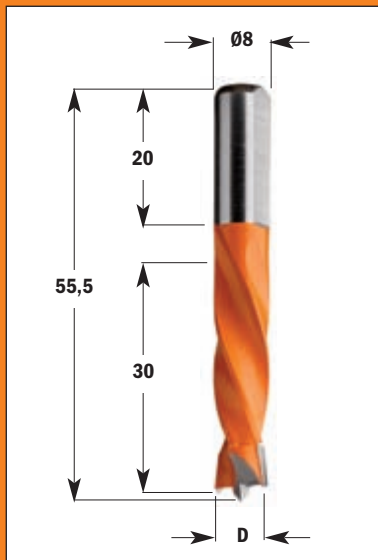

Negatively ground spurs

Shank Ø8x20mm

**306 HW**

D Cutting diameter mm inches	I Cutting length mm	L Overall length mm	ORDER NO.	
			Right-hand rotation	Left-hand rotation
• 3	18	55,5	<b>306.030.21</b>	
5	30	55,5	<b>306.050.11</b>	<b>306.050.12</b>
5,55 7/32	30	55,5	<b>306.055.11</b>	<b>306.055.12</b>
6	30	55,5	<b>306.060.11</b>	<b>306.060.12</b>
6,35 1/4	30	55,5	<b>306.064.11</b>	<b>306.064.12</b>
7	30	55,5	<b>306.070.11</b>	<b>306.070.12</b>
8	30	55,5	<b>306.080.11</b>	<b>306.080.12</b>
9	30	55,5	<b>306.090.11</b>	<b>306.090.12</b>
10	30	55,5	<b>306.100.11</b>	<b>306.100.12</b>
12	30	55,5	<b>306.120.11</b>	<b>306.120.12</b>

• HWM

Shank Ø8x20mm

**307 HW**

D Cutting diameter mm inches	I Cutting length mm	L Overall length mm	ORDER NO.	
			Right-hand rotation	Left-hand rotation
5	40	67	<b>307.050.11</b>	<b>307.050.12</b>
5,55 7/32	40	67	<b>307.055.11</b>	<b>307.055.12</b>
6	40	67	<b>307.060.11</b>	<b>307.060.12</b>
6,35 1/4	40	67	<b>307.064.11</b>	<b>307.064.12</b>
7	40	67	<b>307.070.11</b>	<b>307.070.12</b>
8	40	67	<b>307.080.11</b>	<b>307.080.12</b>
9	40	67	<b>307.090.11</b>	<b>307.090.12</b>
9,52 3/8	40	67	<b>307.095.11</b>	<b>307.095.12</b>
10	40	67	<b>307.100.11</b>	<b>307.100.12</b>
12	40	67	<b>307.120.11</b>	<b>307.120.12</b>

Spare parts

Screw M5x10	<b>990.003.00</b>
-------------	-------------------

TECHNICAL DETAILS:

- Super-strength steel
- Negatively ground spurs (V2)
- 4 spiral flutes
- Cutter body coated with black or orange P.T.F.E.
- HW head with precision balanced centre point
- 2 precision ground HW cutting edges (Z2)
- Parallel shank with driving flat and length adjusting screw.

APPLICATION:

used on boring machines equipped with chucks or adaptors. Used to drill blind holes in solid wood, wood composites, plastic and laminated materials.

**Shank Ø10x20mm**
**308 HW**

D Cutting diameter		I Cutting length	L Overall length	ORDER NO. Right-hand rotation	ORDER NO. Left-hand rotation
mm	inches	mm	mm		
4	5/32	26	57,5	<b>308.040.11</b>	<b>308.040.12</b>
5		30	57,5	<b>308.050.11</b>	<b>308.050.12</b>
6		30	57,5	<b>308.060.11</b>	<b>308.060.12</b>
6,35	1/4	30	57,5	<b>308.064.11</b>	<b>308.064.12</b>
7		30	57,5	<b>308.070.11</b>	<b>308.070.12</b>
8		30	57,5	<b>308.080.11</b>	<b>308.080.12</b>
9		30	57,5	<b>308.090.11</b>	<b>308.090.12</b>
9,52	3/8	30	57,5	<b>308.095.11</b>	<b>308.095.12</b>
10		30	57,5	<b>308.100.11</b>	<b>308.100.12</b>
11		30	57,5	<b>308.110.11</b>	<b>308.110.12</b>
12		30	57,5	<b>308.120.11</b>	<b>308.120.12</b>
12,7	1/2	30	57,5	<b>308.127.11</b>	<b>308.127.12</b>
13		30	57,5	<b>308.130.11</b>	<b>308.130.12</b>
14		30	57,5	<b>308.140.11</b>	<b>308.140.12</b>
15		30	57,5	<b>308.150.11</b>	<b>308.150.12</b>
16		30	57,5	<b>308.160.11</b>	<b>308.160.12</b>

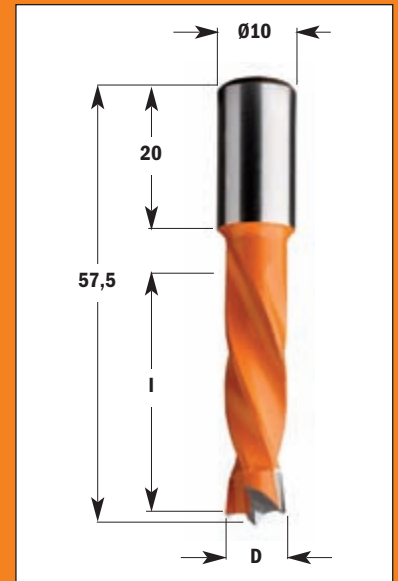
**Shank Ø10x20mm**
**309 HW**

D Cutting diameter		I Cutting length	L Overall length	ORDER NO. Right-hand rotation	ORDER NO. Left-hand rotation
mm	inches	mm	mm		
4	5/32	30	70	<b>309.040.11</b>	<b>309.040.12</b>
5		43	70	<b>309.050.11</b>	<b>309.050.12</b>
6		43	70	<b>309.060.11</b>	<b>309.060.12</b>
6,35	1/4	43	70	<b>309.064.11</b>	<b>309.064.12</b>
7		43	70	<b>309.070.11</b>	<b>309.070.12</b>
7,5		43	70	<b>309.075.11</b>	<b>309.075.12</b>
8		43	70	<b>309.080.11</b>	<b>309.080.12</b>
9		43	70	<b>309.090.11</b>	<b>309.090.12</b>
9,52	3/8	43	70	<b>309.095.11</b>	<b>309.095.12</b>
10		43	70	<b>309.100.11</b>	<b>309.100.12</b>
11		43	70	<b>309.110.11</b>	<b>309.110.12</b>
12		43	70	<b>309.120.11</b>	<b>309.120.12</b>
12,7	1/2	43	70	<b>309.127.11</b>	<b>309.127.12</b>
13		43	70	<b>309.130.11</b>	<b>309.130.12</b>
14		43	70	<b>309.140.11</b>	<b>309.140.12</b>
15		43	70	<b>309.150.11</b>	<b>309.150.12</b>
16		43	70	<b>309.160.11</b>	<b>309.160.12</b>

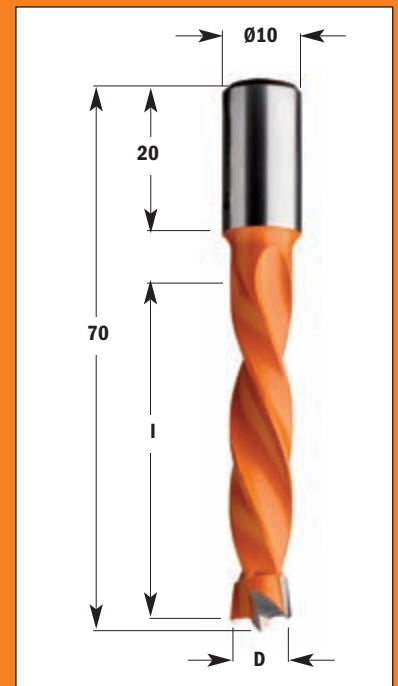
**Spare parts**

Screw M5x10

**990.003.00**
**TECHNICAL DETAILS:**

- Super-strength steel
- Negatively ground spurs (V2)
- 4 spiral flutes
- Cutter portion coated with black or orange P.T.F.E.
- HW head with precision balanced centre point
- 2 precision ground HW cutting edges (Z2)
- Parallel shank with driving flat and length adjusting screw.

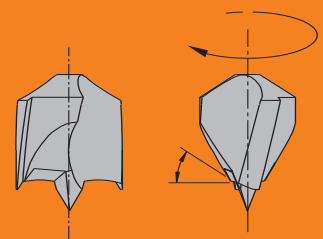
**Negatively ground spurs**



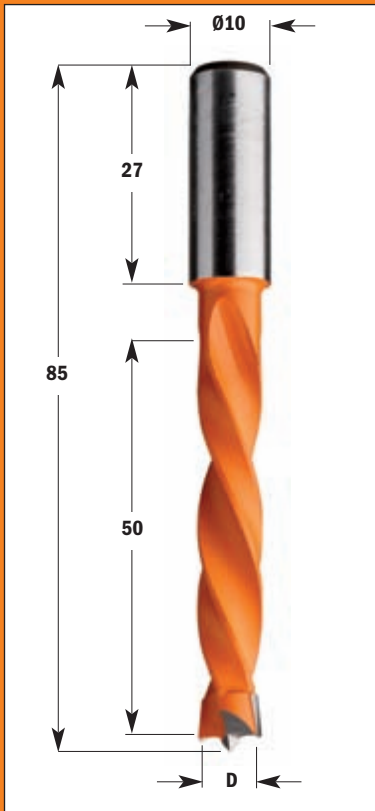

Shank Ø10x27 mm

**373** HW

D Cutting diameter mm	I Cutting length mm	L Overall length mm	ORDER NO. Right-hand rotation	ORDER NO. Left-hand rotation
5	50	85	<b>373.050.11</b>	<b>373.050.12</b>
6	50	85	<b>373.060.11</b>	<b>373.060.12</b>
<b>new</b> 7	50	85	<b>373.070.11</b>	<b>373.070.12</b>
8	50	85	<b>373.080.11</b>	<b>373.080.12</b>
10	50	85	<b>373.100.11</b>	<b>373.100.12</b>
12	50	85	<b>373.120.11</b>	<b>373.120.12</b>

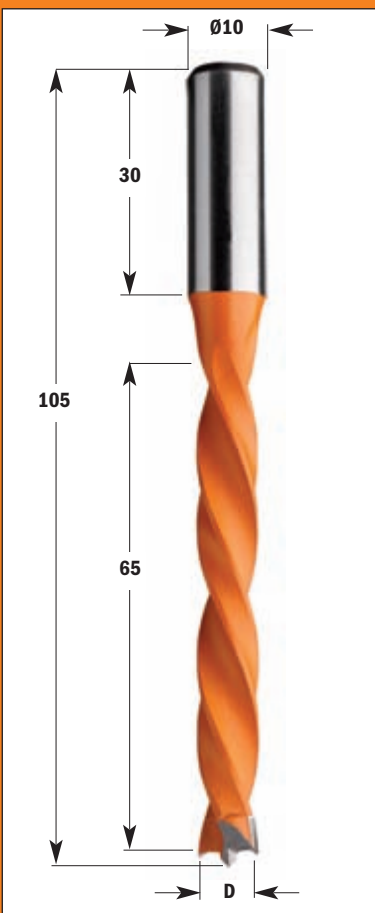

Shank Ø10x30mm

**372** HW

D Cutting diameter mm	I Cutting length mm	L Overall length mm	ORDER NO. Right-hand rotation	ORDER NO. Left-hand rotation
5	65	105	<b>372.050.11</b>	<b>372.050.12</b>
6	65	105	<b>372.060.11</b>	<b>372.060.12</b>
<b>new</b> 7	65	105	<b>372.070.11</b>	<b>372.070.12</b>
8	65	105	<b>372.080.11</b>	<b>372.080.12</b>
10	65	105	<b>372.100.11</b>	<b>372.100.12</b>
12	65	105	<b>372.120.11</b>	<b>372.120.12</b>

Spare parts

Screw M5x10	<b>990.003.00</b>
-------------	-------------------

TECHNICAL DETAILS:

- Super-strength steel
- Negatively ground spurs (V2)
- 4 spiral flutes
- Cutter portion coated with black or orange P.T.F.E.
- HW head with precision balanced centre point
- 2 precision ground HW cutting edges (Z2)
- Parallel shank with driving flat and length adjusting screw.

**APPLICATION:** used on boring machines equipped with adaptors or chucks. Used to drill blind holes in solid wood, wood composites, plastic and laminated materials.

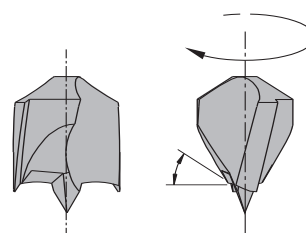

Negatively ground spurs

**Shank Ø10mm**

**376 HW**

D Cutting diameter mm	I Cutting length mm	L Overall length mm	ORDER NO.	
			Right-hand rotation	Left-hand rotation
8	12	57,5	<b>376.080.11</b>	<b>376.080.12</b>
8	15	57,5	<b>376.081.11</b>	<b>376.081.12</b>
8	20	57,5	<b>376.082.11</b>	<b>376.082.12</b>
10	12	57,5	<b>376.100.11</b>	<b>376.100.12</b>
10	15	57,5	<b>376.101.11</b>	<b>376.101.12</b>
10	20	57,5	<b>376.102.11</b>	<b>376.102.12</b>

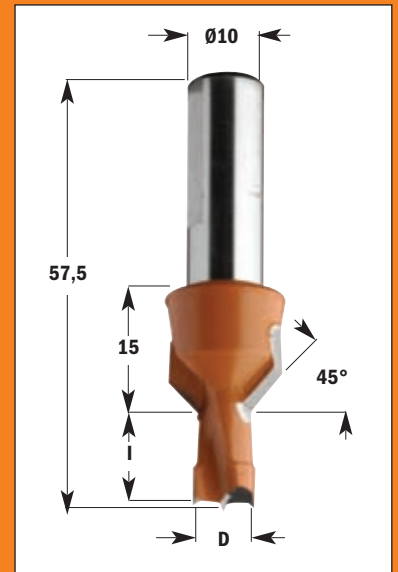

**Shank Ø10mm**

**377 HW**

D Cutting diameter mm	I Cutting length mm	L Overall length mm	ORDER NO.	
			Right-hand rotation	Left-hand rotation
8	12	70	<b>377.080.11</b>	<b>377.080.12</b>
8	15	70	<b>377.081.11</b>	<b>377.081.12</b>
8	20	70	<b>377.082.11</b>	<b>377.082.12</b>
10	12	70	<b>377.100.11</b>	<b>377.100.12</b>
10	15	70	<b>377.101.11</b>	<b>377.101.12</b>
10	20	70	<b>377.102.11</b>	<b>377.102.12</b>

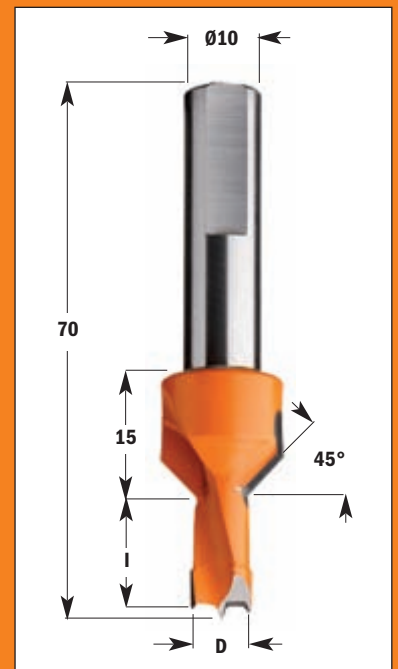

**Spare parts**

Screw M5x10	<b>990.003.00</b>
-------------	-------------------

**TECHNICAL DETAILS:**

- Super-strength steel
- Spiral portion coated with orange or black P.T.F.E.
- HW head with precision balanced centre point
- 2+2 precision ground HW cutting edges (Z2+2)
- 2 negatively ground spurs (V2)
- 2 spiral flutes
- Parallel shank with driving flat and length adjusting screw.

**APPLICATION:** used for drilling and countersinking in solid wood, wood composites, plastic and laminated materials. Suitable for high performance speed on boring machines equipped with adaptors or chucks.

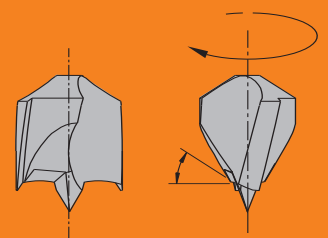

**Negatively ground spurs**

**316** HW Z2

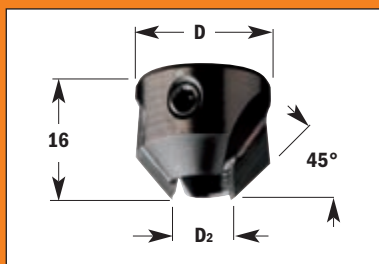

D <sub>2</sub> For bit diameter mm	D Cutting diameter mm	ORDER NO.	
		Right-hand rotation	Left-hand rotation
4	16	<b>316.040.11</b>	<b>316.040.12</b>
5	16	<b>316.050.11</b>	<b>316.050.12</b>
6	16	<b>316.060.11</b>	<b>316.060.12</b>
7	16	<b>316.070.11</b>	<b>316.070.12</b>
8	18	<b>316.080.11</b>	<b>316.080.12</b>
9	18	<b>316.090.11</b>	<b>316.090.12</b>
10	20	<b>316.100.11</b>	<b>316.100.12</b>
12	20	<b>316.120.11</b>	<b>316.120.12</b>

**Spare parts**

Screw M5x5	<b>990.002.00</b>
Allen key 2,5mm	<b>991.062.00</b>

**For assembly on the spiral head of the bit. Adjustable depth.**

**For use with the following parts: 306-307-308-309-373-374-375-338-339-340-341-342-343-344-346-352-353 HW**

**TECHNICAL DETAILS:**

- Super-strength steel
- 2 precision ground HW cutting edges (Z2)

**APPLICATION:** used for drilling and chamfering in solid wood, wood composites, plastic and laminated materials.

## Assembly illustration

for countersink 316 on 4 flutes dowel drills



**315 HW Z2**

D <sub>3</sub> For bit diameter mm	D Cutting diameter mm	ORDER NO.	
		Right-hand rotation	Left-hand rotation
Da 5 a 10	20	<b>315.200.11</b>	<b>315.200.12</b>
Da 11 a 12	22	<b>315.220.11</b>	<b>315.220.12</b>

**Spare parts**

Screw M5x5	<b>990.006.00</b>
Allen key 2,5mm	<b>991.062.00</b>

For assembly on the shank of the drill.

For use with the following parts: **310-311-362-313-314-366 HW**

**TECHNICAL DETAILS:**

- Super-strength steel
- 2 precision ground carbide tipped cutting edges (Z2)
- Clamp directly on to the shank of the drills.

**APPLICATION:** used for chamfering and drilling in solid wood, wood composites, plastic and laminated materials.

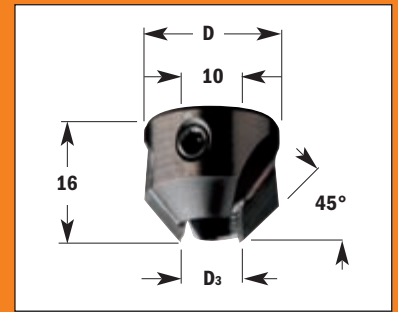

**Assembly illustration**

for countersink 315 on 2 flutes dowel drills





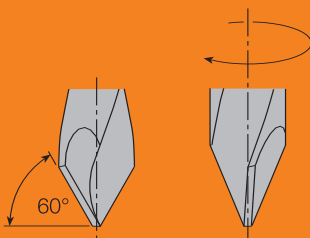
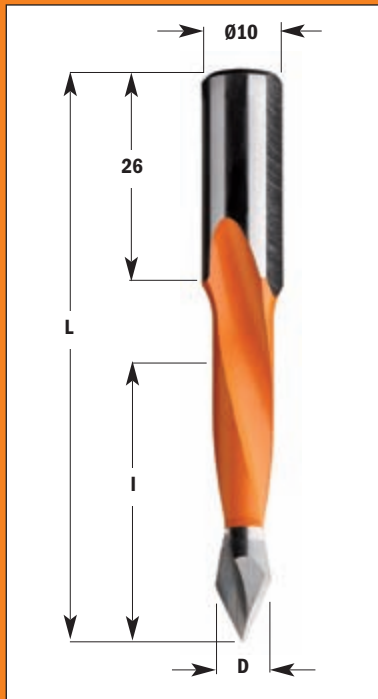
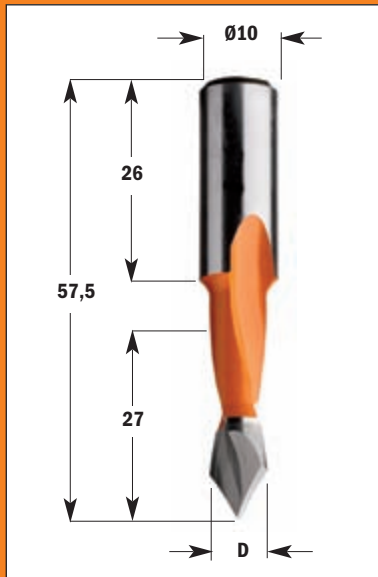

Through holes 60°

### Shank Ø10x26mm

### 313 HW

D Cutting diameter mm	I Cutting length mm	L Overall length mm	ORDER NO. Right-hand rotation	ORDER NO. Left-hand rotation
5	27	57,5	313.050.11	313.050.12
6	27	57,5	313.060.11	313.060.12
8	27	57,5	313.080.11	313.080.12
10	27	57,5	313.100.11	313.100.12

For panels with a 20mm maximum thickness

### Shank Ø10x26mm

### 314 HW

D Cutting diameter mm	inches	I Cutting length mm	L Overall length mm	ORDER NO. Right-hand rotation	ORDER NO. Left-hand rotation
4	5/32	30	70	314.040.11	314.040.12
4,76	3/16	35	70	314.047.11	314.047.12
5		35	70	314.050.11	314.050.12
5,55	7/32	35	70	314.055.11	314.055.12
6		35	70	314.060.11	314.060.12
6,35	1/4	35	70	314.064.11	314.064.12
7		35	70	314.070.11	314.070.12
8		35	70	314.080.11	314.080.12
9		35	70	314.090.11	314.090.12
9,52	3/8	35	70	314.095.11	314.095.12
10		35	70	314.100.11	314.100.12
12		35	70	314.120.11	314.120.12
12,7	1/2	35	70	314.127.11	314.127.12

For panels with a 30mm maximum thickness

### Shank Ø10x26mm

### 366 HW

5	44	77	366.050.11	366.050.12
6	44	77	366.060.11	366.060.12
8	44	77	366.080.11	366.080.12
10	44	77	366.100.11	366.100.12
12	44	77	366.120.11	366.120.12

### Spare parts

Screw M5x10	990.003.00
-------------	------------

For panels with a 40mm maximum thickness

### TECHNICAL DETAILS:

- Super-strength steel
- Spiral portion coated with orange or black P.T.F.E.
- HW head with precision balanced centre point
- 2 precision ground cutting edges (Z2)
- 2 spiral flutes
- Parallel shank with driving flat and length adjusting screw.

**APPLICATION:** used on boring machines and dowel drilling devices.

Use for drilling through holes in solid wood, wood composites, plastic and laminated materials.

Shank Ø10x20mm

**374 HW**

D Cutting diameter mm	I Cutting length mm	L Overall length mm	ORDER NO. Right-hand rotation	ORDER NO. Left-hand rotation
5	30	57,5	<b>374.050.11</b>	<b>374.050.12</b>
8	30	57,5	<b>374.080.11</b>	<b>374.080.12</b>

For panels with a 25mm maximum thickness

Shank Ø10x20mm

**375 HW**

D Cutting diameter mm	I Cutting length mm	L Overall length mm	ORDER NO. Right-hand rotation	ORDER NO. Left-hand rotation
5	40	70	<b>375.050.11</b>	<b>375.050.12</b>
6	40	70	<b>375.060.11</b>	<b>375.060.12</b>
7	40	70	<b>375.070.11</b>	<b>375.070.12</b>
8	40	70	<b>375.080.11</b>	<b>375.080.12</b>
10	40	70	<b>375.100.11</b>	<b>375.100.12</b>

For panels with a 35mm maximum thickness

Spare parts

Screw M5x10	<b>990.003.00</b>
-------------	-------------------

TECHNICAL DETAILS:

- Super-strength steel - Spiral portion coated with orange or black P.T.F.E.
- HW head with precision balanced centre point
- 2 precision ground cutting edges (Z2) - 4 spiral flutes
- Parallel shank with driving flat and length adjusting screw.

**APPLICATION:** used on boring machines and dowel drilling devices.  
Use for drilling through holes in solid wood, wood composites, plastic and laminated materials.

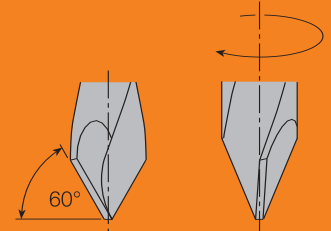
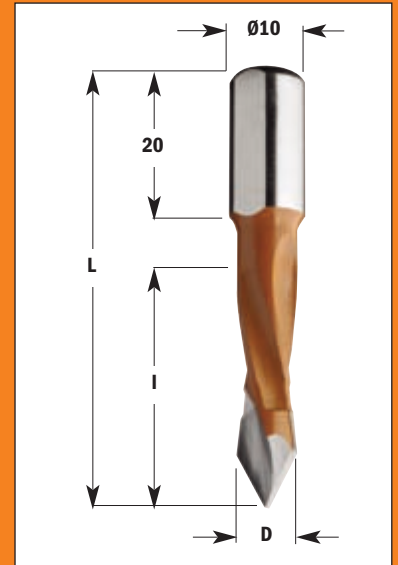

Through holes 60°

2 flute dowel drills for through holes

Shank Ø8x20mm

**367 HW**

D Cutting diameter mm	I Cutting length mm	L Overall length mm	ORDER NO. Right-hand rotation	ORDER NO. Left-hand rotation
5	30	56	<b>367.050.11</b>	<b>367.050.12</b>
8	30	56	<b>367.080.11</b>	<b>367.080.12</b>

For panels with a 25mm maximum thickness

Shank Ø8x20mm

**368 HW**

D Cutting diameter mm	I Cutting length mm	L Overall length mm	ORDER NO. Right-hand rotation	ORDER NO. Left-hand rotation
5	43	70	<b>368.050.11</b>	<b>368.050.12</b>
6	43	70	<b>368.060.11</b>	<b>368.060.12</b>
7	43	70	<b>368.070.11</b>	<b>368.070.12</b>
8	43	70	<b>368.080.11</b>	<b>368.080.12</b>

For panels with a 35-40mm maximum thickness

Spare parts

Screw M5x10	<b>990.003.00</b>
-------------	-------------------

TECHNICAL DETAILS:

- Super-strength steel - Spiral portion coated with orange or black P.T.F.E.
- HW head with precision balanced centre point
- 2 precision ground cutting edges (Z2) - 2 spiral flutes
- Parallel shank with driving flat and length adjusting screw.

**APPLICATION:** used on boring machines and dowel drilling devices.  
Use for drilling through holes in solid wood, wood composites, plastic and laminated materials.

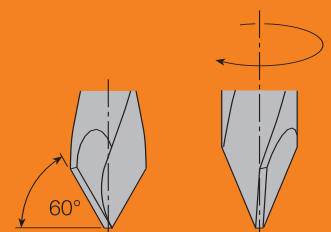
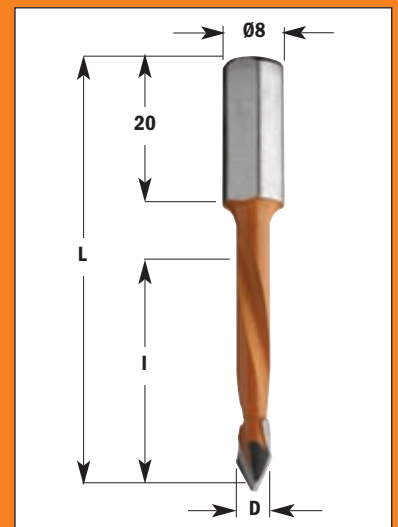

Through holes 60°

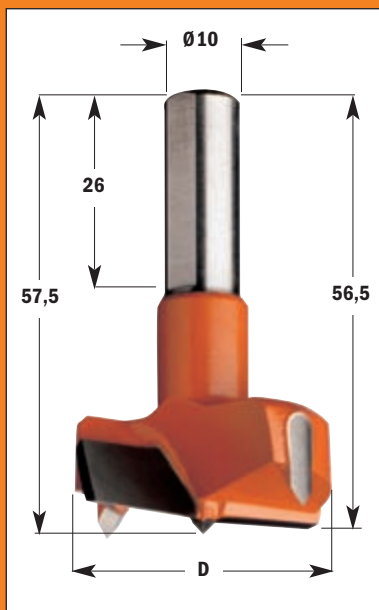

New construction with 1mm centre point

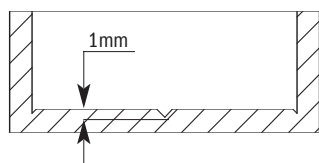

## Shank Ø10x26mm

## 317 HW

D Cutting diameter mm	L Overall length mm	ORDER NO. Right-hand rotation	ORDER NO. Left-hand rotation
14	57,5	317.140.11	317.140.12
15	57,5	317.150.11	317.150.12
16	57,5	317.160.11	317.160.12
17	57,5	317.170.11	317.170.12
18	57,5	317.180.11	317.180.12
19	57,5	317.190.11	317.190.12
20	57,5	317.200.11	317.200.12
22	57,5	317.220.11	317.220.12
24	57,5	317.240.11	317.240.12
25	57,5	317.250.11	317.250.12
26	57,5	317.260.11	317.260.12
28	57,5	317.280.11	317.280.12
30	57,5	317.300.11	317.300.12
32	57,5	317.320.11	317.320.12
34	57,5	317.340.11	317.340.12
35	57,5	317.350.11	317.350.12
38	57,5	317.380.11	317.380.12
40	57,5	317.400.11	317.400.12

### TECHNICAL DETAILS:

- Super-strength steel
- Cutter portion coated with orange or black P.T.F.E.
- HW head with precision balanced centre point
- 2 precision ground HW cutting edges (Z2)
- 2 negatively ground spurs (V2)
- Parallel shank with driving flat and length adjusting screw.

**APPLICATION:** ideal for hinges. Use on boring machines equipped with adaptors or chucks. Use for drilling accurate and clean-cut blind holes in solid wood, wood composites, plastic and laminated materials.

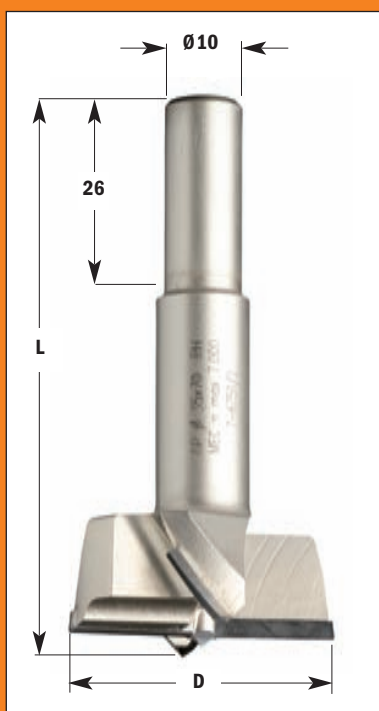

## Shank Ø10x26mm

## 317 DP

D Cutting diameter mm	L Overall length mm	ORDER NO. Right-hand rotation	ORDER NO. Left-hand rotation
15	57,5	317.150.61	317.150.62
35	57,5	317.350.61	317.350.62

## Shank Ø10x26mm

## 369 DP

D Cutting diameter mm	L Overall length mm	ORDER NO. Right-hand rotation	ORDER NO. Left-hand rotation
15	70	369.150.61	369.150.62
35	70	369.350.61	369.350.62

### TECHNICAL DETAILS:

- Super-strength steel
- DP head with precision balanced centre point
- 2 precision ground DP cutting edges (Z2)
- 2 negatively ground DP spurs (V2)
- Parallel shank with driving flat and length adjusting screw.

**APPLICATION:** ideal for hinges. Use on boring machines equipped with adaptors or chucks. Use for drilling accurate and clean-cut blind holes in wood composites, plastic and laminated materials. Long lasting boring performance 20 times comparing to HW material.

Shank Ø10x26mm

**369** HW

D Cutting diameter mm	L Overall length mm	ORDER NO.	
		Right-hand rotation	Left-hand rotation
14	70	369.140.11	369.140.12
15	70	369.150.11	369.150.12
16	70	369.160.11	369.160.12
18	70	369.180.11	369.180.12
20	70	369.200.11	369.200.12
22	70	369.220.11	369.220.12
25	70	369.250.11	369.250.12
26	70	369.260.11	369.260.12
30	70	369.300.11	369.300.12
35	70	369.350.11	369.350.12
40	70	369.400.11	369.400.12

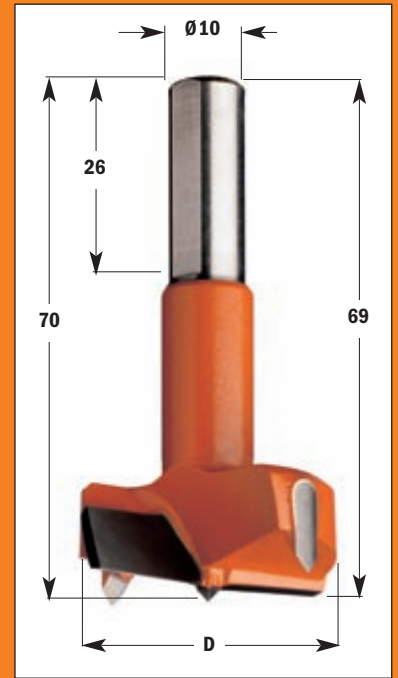

Shank Ø10x30mm

**370** HW

D Cutting diameter mm	L Overall length mm	ORDER NO.	
		Right-hand rotation	Left-hand rotation
18	77	370.180.11	370.180.12
20	77	370.200.11	370.200.12
25	77	370.250.11	370.250.12
30	77	370.300.11	370.300.12
35	77	370.350.11	370.350.12

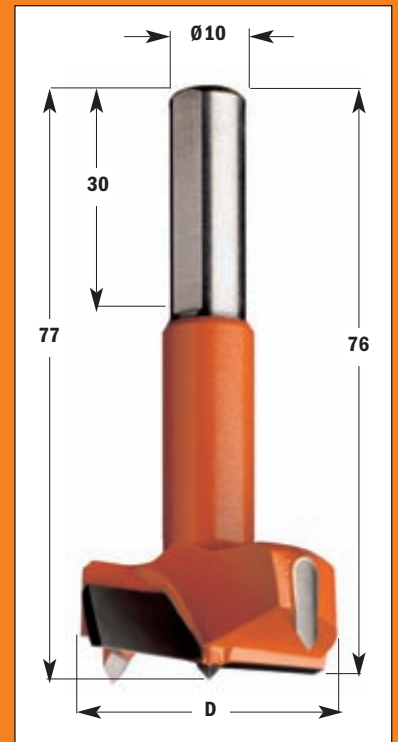

Spare parts

Screw M5x10	990.003.00
-------------	------------

TECHNICAL DETAILS:

- Super-strength steel
- Cutter portion coated with orange or black P.T.F.E.
- HW head with precision balanced centre point
- 2 precision ground HW cutting edges (Z2)
- 2 negatively ground spurs (V2)
- Parallel shank with driving flat and length adjusting screw.

**APPLICATION: ideal for hinges.** Use on boring machines equipped with adaptors or chucks. Use for drilling accurate and clean-cut blind holes in solid wood, wood composites, plastic and laminated materials.

New construction with 1mm centre point

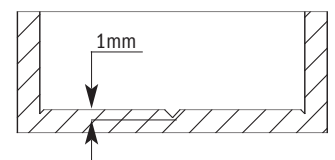

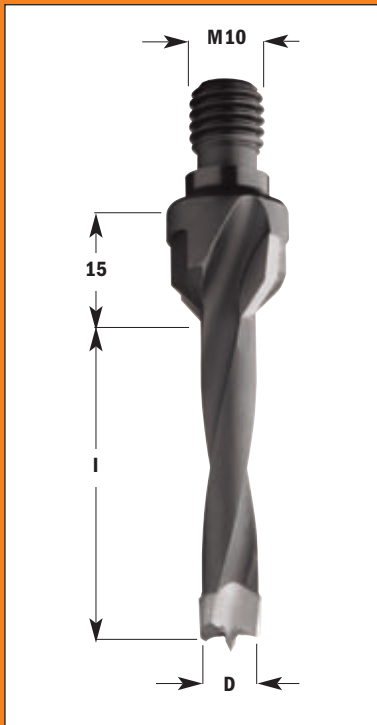

**...with countersink**

Shank M10 with seating Ø11x4mm

**325-327-329-330 HW**

D Cutting diameter mm	I Cutting length mm	ORDER NO. Right-hand rotation	ORDER NO. Left-hand rotation
5	20	325.050.11	325.050.12
6	20	325.060.11	325.060.12
8	20	325.080.11	325.080.12
10	20	325.100.11	325.100.12
12	20	325.120.11	325.120.12
<hr/>			
5	30	327.050.11	327.050.12
6	30	327.060.11	327.060.12
8	30	327.080.11	327.080.12
10	30	327.100.11	327.100.12
12	30	327.120.11	327.120.12
<hr/>			
5	40	329.050.11	329.050.12
6	40	329.060.11	329.060.12
8	40	329.080.11	329.080.12
10	40	329.100.11	329.100.12
12	40	329.120.11	329.120.12
<hr/>			
5	50	330.050.11	330.050.12
6	50	330.060.11	330.060.12
8	50	330.080.11	330.080.12
10	50	330.100.11	330.100.12
12	50	330.120.11	330.120.12

**TECHNICAL DETAILS:**

- Super-strength steel
- HW head with precision balanced centre point
- 2+2 precision ground cutting edge [Z2+2]
- 2 spiral flutes
- 2 ground spurs (V2)

**APPLICATION:** used on boring machines equipped with chucks.

Used to drill blind holes in solid wood, wood composites, plastic and laminated materials.



**...without countersink**

Shank M10 with seating Ø11x4mm

**338-339-340 HW**

D Cutting diameter mm	I Cutting length mm	ORDER NO. Right-hand rotation	ORDER NO. Left-hand rotation
5	30	338.050.11	338.050.12
6	30	338.060.11	338.060.12
8	30	338.080.11	338.080.12
10	30	338.100.11	338.100.12
12	30	338.120.11	338.120.12
<hr/>			
5	40	339.050.11	339.050.12
6	40	339.060.11	339.060.12
8	40	339.080.11	339.080.12
10	40	339.100.11	339.100.12
12	40	339.120.11	339.120.12
<hr/>			
5	50	340.050.11	340.050.12
6	50	340.060.11	340.060.12
8	50	340.080.11	340.080.12
10	50	340.100.11	340.100.12
12	50	340.120.11	340.120.12

**TECHNICAL DETAILS:**

- Super-strength steel
- HW head with precision balanced centre point
- 2 precision ground cutting edges (Z2)
- 2 ground spurs (V2) - 4 spiral flutes

**APPLICATION:** used on boring machines equipped with chucks.

Used to drill blind holes in solid wood, wood composites, plastic and laminated materials.



**Shank M8**

**344 HW**

D Cutting diameter mm	I Cutting length mm	LB Adjusting length mm	ORDER NO. Right-hand rotation	ORDER NO. Left-hand rotation
5	43	63	<b>344.050.11</b>	<b>344.050.12</b>
6	43	63	<b>344.060.11</b>	<b>344.060.12</b>
8	43	63	<b>344.080.11</b>	<b>344.080.12</b>
10	43	63	<b>344.100.11</b>	<b>344.100.12</b>
12	43	63	<b>344.120.11</b>	<b>344.120.12</b>

**FOR USE ON THE FOLLOWING MACHINES:**

Nottmeyer (older models)

**Shank M10**

**346 HW**

D Cutting diameter mm	I Cutting length mm	LB Adjusting length mm	ORDER NO. Right-hand rotation	ORDER NO. Left-hand rotation
5	43	63	<b>346.050.11</b>	<b>346.050.12</b>
6	43	63	<b>346.060.11</b>	<b>346.060.12</b>
8	43	63	<b>346.080.11</b>	<b>346.080.12</b>
10	43	63	<b>346.100.11</b>	<b>346.100.12</b>
12	43	63	<b>346.120.11</b>	<b>346.120.12</b>

**FOR USE ON THE FOLLOWING MACHINES:**

Ayen, Holzma, Knoevenagel, Mayer, Torwegge

**TECHNICAL DETAILS:**

- Super-strength steel
- HW head with precision balanced centre point
- 2 precision ground cutting edges (Z2)
- 2 ground spurs (V2)
- 4 spiral flutes

**APPLICATION:** used on boring machines equipped with chucks.

Used to drill blind holes in solid wood, wood composites, plastic and laminated materials.

**...without countersink**

**Shank M8 with seating Ø9x4mm**

**352-353 HW**

D Cutting diameter mm	I Cutting length mm	ORDER NO. Right-hand rotation	ORDER NO. Left-hand rotation
5	30	<b>352.050.11</b>	<b>352.050.12</b>
6	30	<b>352.060.11</b>	<b>352.060.12</b>
8	30	<b>352.080.11</b>	<b>352.080.12</b>
10	30	<b>352.100.11</b>	<b>352.100.12</b>
12	30	<b>352.120.11</b>	<b>352.120.12</b>
5	40	<b>353.050.11</b>	<b>353.050.12</b>
6	40	<b>353.060.11</b>	<b>353.060.12</b>
8	40	<b>353.080.11</b>	<b>353.080.12</b>
10	40	<b>353.100.11</b>	<b>353.100.12</b>
12	40	<b>353.120.11</b>	<b>353.120.12</b>

**FOR USE ON THE FOLLOWING MACHINES:**

Masterwood (Zangheri & Boschetti)  
Morbidelli, Nottmeyer (new design)

**TECHNICAL DETAILS:**

- Super-strength steel
- HW head with precision balanced centre point
- 2 precision ground cutting edges (Z2)
- 2 ground spurs (V2)
- 4 spiral flutes

**APPLICATION:** used on boring machines equipped with chucks.

Used to drill blind holes in solid wood, wood composites, plastic and laminated materials.

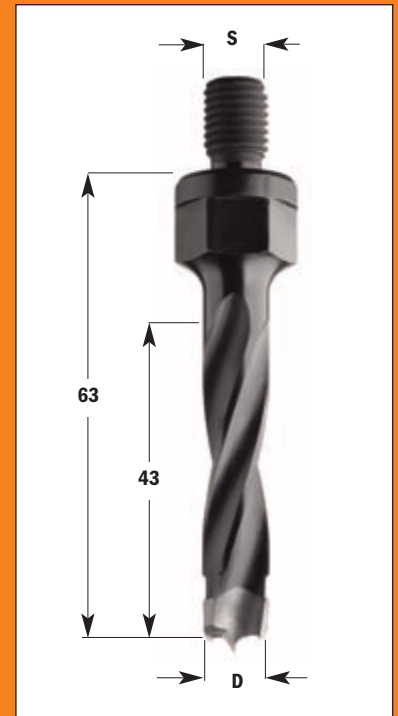

**TOOL FEATURES**

**TOOL MATERIAL**

- HW  SP steel

**QUANTITY AND ROTATION**

Nr. .... Bits RH Nr. .... Bits LH

**SHANK**

**- PARALLEL SHANK WITH DRIVING FLAT**

- Ø8x20 with driving flat and length adjusting screw  
 Ø10x20 with driving flat and length adjusting screw

**- THREADED SHANK**

- M8  
 M10  
 M8 with seating Ø9 x 4  
 M10 with seating Ø11 x 4  
 M 8 with 20°48' centring cone  
 M10 with 30° centring cone

**- PARALLEL SHANK**

- S x A = .....  
 (Specify diameter and length of shank)  
 .....  
 (Specify other kind of shank)

**HOLE FEATURES**

**HOLE TO REALISE**

- Drawing 1 - Blind hole with more than one diameter  
 Drawing 2 - Blind hole with counter  
 Drawing 3 - Through hole with more than one diameter  
 Drawing 4 - Through hole with countersink

**DIMENSIONS**

d x C .....  
 (Specify diameter and depth of first hole)

D x B .....  
 (Specify diameter and depth of second hole)

 .....  
 (Specify countersink-angle) "standard 45°"

**WORK MATERIAL**

- Solid wood  
 MDF/Melamine panels  
 Chipboard panels and hard wood  
 .....  
 (Specify other materials)

**MACHINE DATA**

Manufacturer/Model .....  
 RPM .....  
 Feed speed (metres/minute) .....

**DRAWING 1**

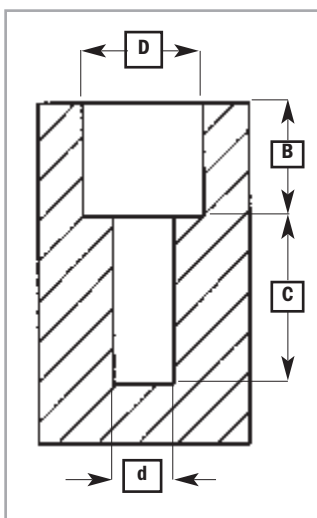

**DRAWING 2**

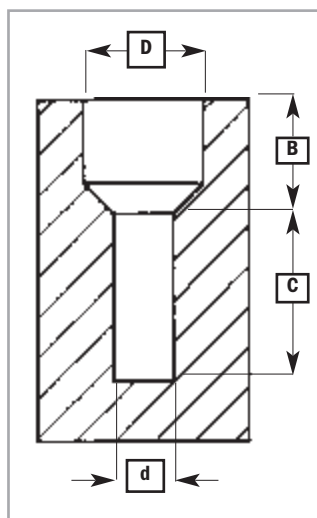

**DRAWING 3**

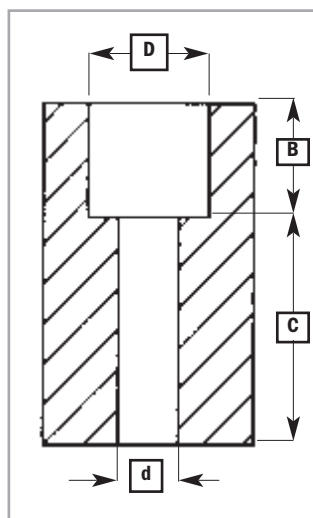

**DRAWING 4**

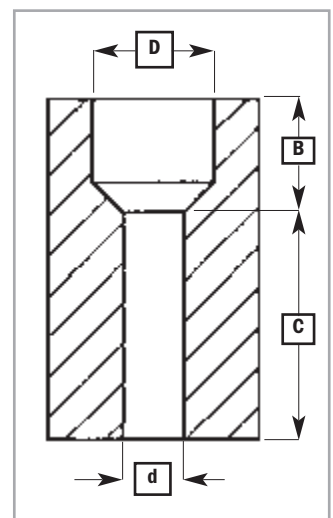

For orders, please fill out this form and fax to:

**#39 0721 481021** or mail to:

**C.M.T. Utensili S.p.A. - Via della Meccanica, s.n. - 61020 Chiusa di Ginestreto (Pesaro) - Italia**



## Display cabinets

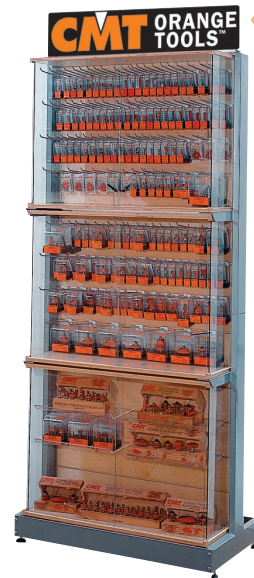

Router bits &  
Saw blades  
270



Router bits  
272



Saw blades  
273



Cutter heads & Knives  
276



Drill & Boring bits  
277



This sturdy structure is hand-crafted using wood, tempered glass and iron and is free-standing to offer 360° visibility and to give you the versatility of positioning the display anywhere you like in the store. The front is a convenient 3 component assembly. The two upper sections are designed to display 141 of the best selling router bits from the CMT router bits line and 20 corresponding spare parts; while 10 of the popular wooden box sets can fit perfectly in the lower section if required. On the other side you can display up to 15 different types of saw blades; 4 of which can be up to 185mm in diameter, 9 of which can be up to 250mm and 2 up to 350mm in diameter.

Dimensions are in cm.

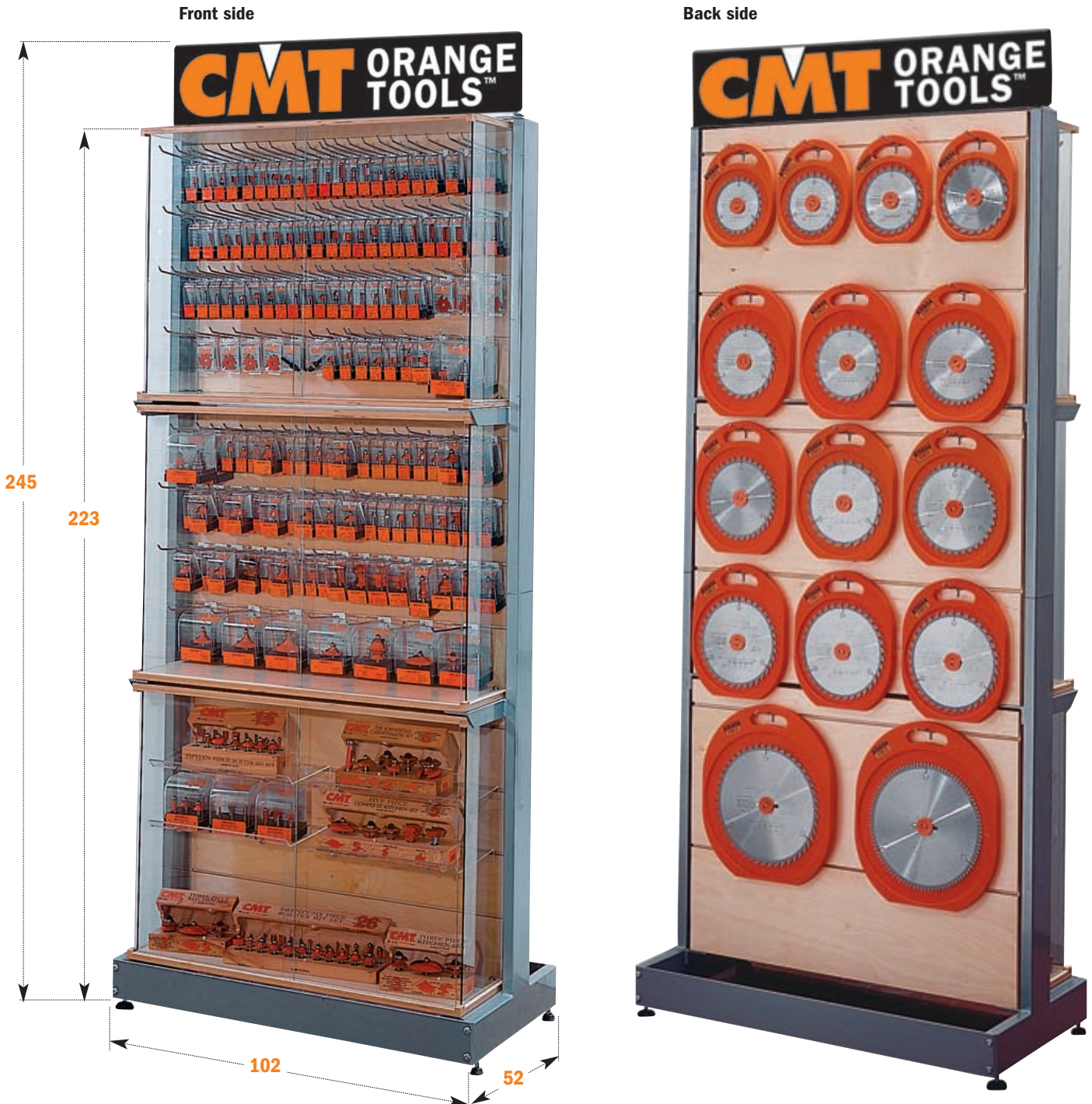

DESCRIPTION	ORDER NO.
Display cabinets with: 240 HW router bits (S=Ø6mm), 21 HW router bits (S=Ø12mm), 60 spare parts, 30 HW saw blades	700.351.00
Display cabinets with: 240 HW router bits (S=Ø8mm), 21 HW router bits (S=Ø12mm), 60 spare parts, 30 HW saw blades	900.351.00
Display cabinets with: 240 HW router bits (S=Ø6mm), 60 spare parts (saw blades at your choice)	700.300.00L
Display cabinets with: 240 HW router bits (S=Ø8mm), 60 spare parts (saw blades at your choice)	900.300.00L
21 pcs. HW router bits with shank Ø12mm for our display cabinet	900.021.00
30 pcs. HW saw blade	200.030.00
Display cabinet only	03.00.0025

## 700.351.00 Shank Ø6-12mm

Order no.	Description	Q.tà	Order no.	Description	Q.tà	Order no.	Description	Q.tà
<b>700.240.00 KIT 240 ROUTER BITS WITH SHANK Ø6MM</b>						<b>900.021.00 KIT 21 ROUTER BITS WITH SHANK Ø12 MM</b>		
701.127.11	Mortising bit	2	718.158.11	Dovetail bit	2	900.506.11	Three wing slot cutter set	1
701.160.11	Mortising bit	2	718.190.11	Dovetail bit	2	918.658.11	Dovetail bit	1
701.190.11	Mortising bit	2	721.030.11	Combination trimmer bit	2	938.990.11	Ovolo bit with bearing	1
701.190.11B	Mortising bit	2	724.060.10	Slot cutter arbor	2	938.991.11	Ovolo bit with bearing	1
703.240.11	Chamfer bit	2	727.040.11	Ovolo bit	2	938.992.11	Ovolo bit with bearing	1
704.240.11	Chamfer bit	2	727.050.11	Ovolo bit	2	938.993.11	Ovolo bit with bearing	1
705.240.11	Chamfer bit	2	727.060.11	Ovolo bit	2	954.507.11	Bull nose bit	1
706.095.11	Flush trim bit w/bearing	2	727.080.11	Ovolo bit	2	954.509.11	Bull nose bit	1
706.096.11	Flush trim bit w/bearing	2	727.095.11	Ovolo bit	2	955.501.11	Reverse glue joint bit	1
706.127.11	Flush trim bit w/bearing	2	735.317.11	Rabbeting bit w/bearing	2	955.601.11	Finger pull bit	1
706.128.11	Flush trim bit w/bearing	2	736.130.11	Chamfer bit w/bearing	2	955.901.11	Molding bit with bearing	1
706.190.11	Flush trim bit w/bearing	2	736.190.11	Chamfer bit w/bearing	2	955.902.11	Molding bit with bearing	1
707.210.11	Combination flush and bevel trim bit	2	736.280.11	Chamfer bit w/bearing	2	956.501.11	Molding bit with bearing	1
709.260.11	Bevel trim and chamfer bit	2	736.420.11	Chamfer bit w/bearing	2	956.601.11	Table edge and hand rail bit	1
710.260.11	Bevel trim and chamfer bit	2	737.190.11	Round nose bit w/bearing	2	956.701.11	Table edge and hand rail bit	1
711.020.11	Straight bit	2	737.222.11	Round nose bit w/bearing	2	956.801.11	Multiprofile bit with bearing	1
711.030.11	Straight bit	2	737.254.11	Round nose bit w/bearing	2	956.802.11	Multiprofile bit with bearing	1
711.040.11	Straight bit	2	737.286.11	Round nose bit w/bearing	2	956.851.11	CMT molding system	1
711.050.11	Straight bit	2	737.350.11	Round nose bit w/bearing	2	956.852.11	CMT molding system	1
711.060.11	Straight bit	2	738.160.11	Ovolo bit w/bearing	2	990.501.11	Raised panel bit	1
711.070.11	Straight bit	2	738.190.11	Ovolo bit w/bearing	2	991.501.11	Rail & Stile set	1
711.080.11	Straight bit	2	738.222.11	Ovolo bit w/bearing	2	<b>200.030.00 KIT WITH 30 SAW BLADES</b>		
711.090.11	Straight bit	2	738.254.11	Ovolo bit w/bearing	2	291.150.24H	Saw blade 150x2.4x20	Z=24
711.100.11	Straight bit	2	738.286.11	Ovolo bit w/bearing	2	291.160.24H	Saw blade 160x2.6x20	Z=24
711.110.11	Straight bit	2	738.317.11	Ovolo bit w/bearing	2	291.170.24M	Saw blade 170x2.6x30	Z=24
711.120.11	Straight bit	2	738.380.11	Ovolo bit w/bearing	2	291.180.24M	Saw blade 180x2.6x30	Z=24
711.130.11	Straight bit	2	740.270.11	Roman ogee bit w/bearing	2	291.190.24H	Saw blade 190x2.6x20	Z=24
711.130.11B	Straight bit	2	740.350.11	Roman ogee bit w/bearing	2	291.190.24M	Saw blade 190x2.6x20	Z=24
711.140.11	Straight bit	2	741.285.11	Roman ogee bit w/bearing	2	291.200.36M	Saw blade 200x2.8x30	Z=36
711.150.11	Straight bit	2	741.380.11	Roman ogee bit w/bearing	2	291.210.36M	Saw blade 210x2.8x30	Z=36
711.150.11B	Straight bit	2	742.287.11	Roman ogee bit w/bearing	2	291.216.48M	Saw blade 216x2.8x30	Z=48
711.160.11	Straight bit	2	744.350.11	Roman ogee bit w/bearing	2	291.230.36M	Saw blade 230x2.8x30	Z=36
711.180.11	Straight bit	2	745.287.11	Roman ogee bit w/bearing	2	291.240.36M	Saw blade 240x2.8x30	Z=36
711.190.11	Straight bit	2	745.350.11	Roman ogee bit w/bearing	2	285.040.10M	Saw blade 250x3.2x30	Z=40
711.190.11B	Straight bit	2	746.325.11	Roman ogee bit w/bearing	2	285.060.10M	Saw blade 250x3.2x30	Z=60
711.200.11	Straight bit	2	747.325.11	Roman ogee bit w/bearing	2	285.048.12M	Saw blade 300x3.2x30	Z=48
711.220.11	Straight bit	2	748.190.11	Roman ogee bit	2	285.054.14M	Saw blade 350x3.5x30	Z=54
711.240.11	Straight bit	2	748.190.11B	Roman ogee bit w/bearing	2	<b>900.060.00 KIT WITH 60 SPARE PARTS</b>		
711.250.11	Straight bit	2	749.001.11	60° Lettering bit	2	541.003.00	Stop collar for top bearing bit	3
712.060.11	Straight bit	2	750.001.11	Keyhole bit	2	541.004.00	Stop collar for top bearing bit	3
712.080.11	Straight bit	2	751.002.11	Bowl and tray bit	2	791.002.00	Bearing	3
712.100.11	Straight bit	2	751.002.11B	Bowl and tray bit	2	791.003.00	Bearing	3
712.120.11	Straight bit	2	753.001.11	Flush and V-groove bit	2	791.004.00	Bearing	3
712.150.11B	Straight bit	2	754.002.11	Bull nose bit	2	791.006.00	Bearing	3
712.160.11	Straight bit	2	754.003.11	Bull nose bit	2	791.007.00	Bearing	3
714.032.11	Round nose bit	2	754.004.11	Bull nose bit	2	791.012.00	Bearing	3
714.060.11	Round nose bit	2	758.001.11	Laser point bit (60°)	2	791.018.00	Bearing	3
714.095.11	Round nose bit	2	759.040.11	Roman ogee bit w/bearing	2	791.023.00	Bearing	3
714.127.11	Round nose bit	2	759.064.11	Roman ogee bit w/bearing	2	791.024.00	Bearing	3
714.160.11	Round nose bit	2	760.040.11	Roman ogee bit w/bearing	2	791.025.00	Bearing	3
714.190.11	Round nose bit	2	760.064.11	Roman ogee bit w/bearing	2	799.060.00	Bushing	3
714.190.11B	Round nose bit	2	796.000.00	Collet chuck	2	990.004.00	Bearing screw	3
715.060.11	V-Grooving bit (90°)	2	796.560.00	Collet	2	990.005.00	Bearing screw	3
715.095.11	V-Grooving bit (90°)	2	796.580.00	Collet	2	990.058.00	Bearing screw	3
715.127.11	V-Grooving bit (90°)	2	796.595.00	Collet	2	990.059.00	Bearing screw	3
715.190.11	V-Grooving bit (90°)	2	822.320.11	Slot cutter	2	991.056.00	Hex key for bearing screw	3
715.190.11B	V-Grooving bit (90°)	2	822.325.11	Slot cutter	2	991.057.00	Hex key for bearing screw	3
716.060.11	Panel pilot bit	2	822.330.11	Slot cutter	2	991.062.00	Hex key for bearing screw	3
716.061.11	Panel pilot bit	2	822.335.11	Slot cutter	2			
718.095.11	Dovetail bit	2	822.340.11	Slot cutter	2			
718.127.11	Dovetail bit	2	822.350.11	Slot cutter	2			
			822.360.11	Slot cutter	2			

## 900.351.00 Shank Ø8-12mm

Order no.	Description	Q.tà	Order no.	Description	Q.tà	Order no.	Description	Q.tà
<b>900.240.00 KIT 240 ROUTER BITS WITH SHANK Ø8MM</b>						<b>900.021.00 KIT 21 ROUTER BITS WITH SHANK Ø12MM</b>		
901.127.11	Mortising bit	2	921.030.11	Combination trimmer bit	2	900.506.11	Slot cutter set	1
901.160.11	Mortising bit	2	924.080.00	Slot cutter arbor	2	918.658.11	Dovetail bit	1
901.160.11B	Mortising bit w/bearing	2	924.080.10	Slot cutter arbors w/bearing	2	938.990.11	Ovolo bit with bearing	1
901.180.11	Mortising bit	2	927.040.11	Ovolo bit	2	938.991.11	Ovolo bit with bearing	1
901.190.11	Mortising bit	2	927.050.11	Ovolo bit	2	938.992.11	Ovolo bit with bearing	1
901.200.11	Mortising bit	2	927.060.11	Ovolo bit	2	938.993.11	Ovolo bit with bearing	1
903.240.11	Chamfer bit	2	927.080.11	Ovolo bit	2	954.507.11	Bull nose bit	1
904.240.11	Chamfer bit	2	927.095.11	Ovolo bit	2	954.509.11	Bull nose bit	1
905.240.11	Chamfer bit	2	935.001.11	Rabbeting bit w/bearing	2	955.501.11	Reverse glue joint bit	1
906.095.11	Flush trim bit w/bearing	2	935.317.11	Rabbeting bit w/bearing	2	955.601.11	Finger pull bit	1
906.096.11	Flush trim bit w/bearing	2	935.350.11	Rabbeting bit w/bearing	2	955.901.11	Molding bit with bearing	1
906.127.11	Flush trim bit w/bearing	2	935.502.11	Rabbeting set w/bearing	2	955.902.11	Molding bit with bearing	1
906.128.11	Flush trim bit w/bearing	2	936.130.11	Chamfer bit w/bearing	2	955.901.11	Molding bit with bearing	1
906.190.11	Flush trim bit w/bearing	2	936.190.11	Chamfer bit w/bearing	2	956.601.11	Table edge and hand rail bit	1
907.210.11	Combination flush and bevel trim bit	2	936.280.11	Chamfer bit w/bearing	2	956.701.11	Table edge and hand rail bit	1
909.260.11	Bevel trim and chamfer bit w/bearing	2	936.420.11	Chamfer bit w/bearing	2	956.801.11	Multiprofile bit w/bearing	1
910.260.11	Bevel trim and chamfer bit w/bearing	2	937.190.11	Round nose bit w/bearing	2	956.802.11	Multiprofile bit w/bearing	1
911.030.11	Straight bit	2	937.222.11	Round nose bit w/bearing	2	956.851.11	CMT molding system	1
911.040.11	Straight bit	2	937.254.11	Round nose bit w/bearing	2	956.852.11	CMT molding system	1
911.050.11	Straight bit	2	937.286.11	Round nose bit w/bearing	2	990.501.11	Raised panel bit	1
911.060.11	Straight bit	2	937.350.11	Round nose bit w/bearing	2	991.501.11	Rail & Stile set	1
911.070.11	Straight bit	2	938.160.11	Ovolo bit w/bearing	2	<b>200.030.00 KIT WITH 30 SAW BLADES</b>		
911.080.11	Straight bit	2	938.190.11	Ovolo bit w/bearing	2	291.150.24H	Saw blade 150x2.4x20	Z=24
911.090.11	Straight bit	2	938.222.11	Ovolo bit w/bearing	2	291.160.24H	Saw blade 160x2.6x20	Z=24
911.100.11	Straight bit	2	938.254.11	Ovolo bit w/bearing	2	291.170.24M	Saw blade 170x2.6x30	Z=24
911.120.11	Straight bit	2	938.286.11	Ovolo bit w/bearing	2	291.180.24M	Saw blade 180x2.6x30	Z=24
911.140.11	Straight bit	2	938.317.11	Ovolo bit w/bearing	2	291.190.24H	Saw blade 190x2.6x20	Z=24
911.150.11	Straight bit	2	938.380.11	Ovolo bit w/bearing	2	291.190.24M	Saw blade 190x2.6x20	Z=24
911.160.11	Straight bit	2	938.445.11	Ovolo bit w/bearing	2	291.200.36M	Saw blade 200x2.8x30	Z=36
911.160.11B	Straight bit w/bearing	2	940.270.11	Roman ogee bit w/bearing	2	291.210.36M	Saw blade 210x2.8x30	Z=36
911.180.11	Straight bit	2	940.350.11	Roman ogee bit w/bearing	2	291.216.48M	Saw blade 216x2.8x30	Z=48
911.200.11	Straight bit	2	941.285.11	Roman ogee bit w/bearing	2	291.230.36M	Saw blade 230x2.8x30	Z=36
911.220.11	Straight bit	2	941.380.11	Roman ogee bit w/bearing	2	291.240.36M	Saw blade 240x2.8x30	Z=36
911.220.11B	Straight bit w/bearing	2	942.287.11	Roman ogee bit w/bearing	2	285.040.10M	Saw blade 250x3.2x30	Z=40
911.240.11	Straight bit	2	944.350.11	Roman ogee bit w/bearing	2	285.060.10M	Saw blade 250x3.2x30	Z=60
911.250.11	Straight bit	2	945.287.11	Roman ogee bit w/bearing	2	285.048.12M	Saw blade 300x3.2x30	Z=48
912.060.11	Straight bit	2	945.350.11	Roman ogee bit w/bearing	2	285.054.14M	Saw blade 350x3.5x30	Z=54
912.080.11	Straight bit	2	946.325.11	Roman ogee bit w/bearing	2	<b>900.060.00 KIT WITH 60 SPARE PARTS</b>		
912.100.11	Straight bit	2	947.325.11	Roman ogee bit w/bearing	2	541.003.00	Stop collar for top bearing bit	3
912.120.11	Straight bit	2	948.190.11	Roman ogee bit	2	541.004.00	Stop collar for top bearing bit	3
912.140.11	Straight bit	2	950.001.11	Keyhole bit	2	791.002.00	Bearing	3
912.150.11	Straight bit	2	951.002.11	Bowl and tray bit	2	791.003.00	Bearing	3
912.160.11	Straight bit	2	953.001.11	Flush and V-groove w/bearing	2	791.004.00	Bearing	3
912.160.11B	Straight bit w/bearing	2	954.002.11	Bull nose bit	2	791.006.00	Bearing	3
914.032.11	Round nose bit	2	954.003.11	Bull nose bit	2	791.007.00	Bearing	3
914.060.11	Round nose bit	2	954.004.11	Bull nose bit	2	791.012.00	Bearing</	



A beautiful, well-organized display of router bits in your shop is the best way to encourage customers to buy. CMT has produced this beautiful cabinet to best show off our wide selection of high quality bright orange bits. Made with a sturdy hardwood frame and three glass panels, it is the ideal counter-top display. Holds 42 of our most popular router bits and spare parts - 2 pcs. each for 84 pcs. total or 3 pcs. each for 126 pcs. total. The wooden slat back wall allows for easy bit organization and comes standard with front door lock. The cabinet is available with router bits with 6mm and 8mm shanks.

Dimensions are in cm.



## 700.084.00 Shank Ø6mm

Order no.	Description	Q.tà
701.190.11	Mortising bit	2
706.096.11	Flush trim bit w/bearing	2
706.127.11	Flush trim bit w/bearing	2
706.190.11	Flush trim bit w/bearing	2
711.030.11	Straight bit	2
711.040.11	Straight bit	2
711.050.11	Straight bit	2
711.060.11	Straight bit	2
711.080.11	Straight bit	2
711.100.11	Straight bit	2
711.120.11	Straight bit	2
711.160.11	Straight bit	2
711.200.11	Straight bit	2
712.060.11	Straight bit	2
712.120.11	Straight bit	2
714.060.11	Round nose bit	2
714.095.11	Round nose bit	2
715.060.11	V-Grooving bit (90°)	2
715.127.11	V-Grooving bit (90°)	2
716.060.11	Panel pilot bit	2
718.127.11	Dovetail bit	2
727.060.11	Ovolo bit	2
735.317.11	Rabbeting bit w/bearing	2
736.190.11	Chamfer bit w/bearing	2
736.280.11	Chamfer bit w/bearing	2
737.222.11	Round nose bit w/bearing	2
737.286.11	Round nose bit w/bearing	2
737.350.11	Round nose bit w/bearing	2
738.254.11	Ovolo bit w/bearing	2
738.317.11	Ovolo bit w/bearing	2
738.380.11	Ovolo bit w/bearing	2
740.270.11	Roman ogee bit w/bearing	2
741.285.11	Roman ogee bit w/bearing	2
744.287.11	Roman ogee bit w/bearing	2
746.325.11	Roman ogee bit w/bearing	2
748.190.11	Roman ogee bit	2
754.003.11	Bull nose bit	2
759.040.11	Roman ogee bit w/bearing	2
791.002.00	Bearing	2
791.003.00	Bearing	2
990.058.00	Bearing screw	2
991.057.00	Hex key for bearing screw	2

## 900.084.00 Shank Ø8mm

Order no.	Description	Q.tà
901.190.11	Mortising bit	2
906.096.11	Flush trim bit w/bearing	2
906.127.11	Flush trim bit w/bearing	2
906.190.11	Flush trim bit w/bearing	2
911.030.11	Straight bit	2
911.040.11	Straight bit	2
911.050.11	Straight bit	2
911.060.11	Straight bit	2
911.080.11	Straight bit	2
911.100.11	Straight bit	2
911.120.11	Straight bit	2
911.160.11	Straight bit	2
911.200.11	Straight bit	2
912.060.11	Straight bit	2
912.120.11	Straight bit	2
914.060.11	Round nose bit	2
914.095.11	Round nose bit	2
915.060.11	V-Grooving bit (90°)	2
915.127.11	V-Grooving bit (90°)	2
916.080.11	Panel pilot bit	2
918.127.11	Dovetail bit	2
927.060.11	Ovolo bit	2
935.317.11	Rabbeting bit w/bearing	2
936.190.11	Chamfer bit w/bearing	2
936.280.11	Chamfer bit w/bearing	2
937.222.11	Round nose bit w/bearing	2
937.286.11	Round nose bit w/bearing	2
937.350.11	Round nose bit w/bearing	2
938.254.11	Ovolo bit w/bearing	2
938.317.11	Ovolo bit w/bearing	2
938.380.11	Ovolo bit w/bearing	2
940.270.11	Roman ogee bit w/bearing	2
941.285.11	Roman ogee bit w/bearing	2
944.287.11	Roman ogee bit w/bearing	2
946.325.11	Roman ogee bit w/bearing	2
948.190.11	Roman ogee bit	2
954.003.11	Bull nose bit	2
959.040.11	Roman ogee bit w/bearing	2
791.002.00	Bearing	2
791.003.00	Bearing	2
990.058.00	Bearing screw	2
991.057.00	Hex key for bearing screw	2

### DESCRIPTION

### ORDER NO.

Display cabinet with: 76 HW Router bits (S=Ø6mm), 8 Spare parts (2 pcs. each)

**700.084.00**

Display cabinet with: 76 HW Router bits (S=Ø8mm), 8 Spare parts (2 pcs. each)

**900.084.00**

Display cabinet only

**03.00.0000**

This sturdy structure is hand-crafted using wood and iron and is free-standing to offer 360° visibility and to give you the versatility of positioning the display anywhere you like in the store.

In both the front and the back of the display, you can hang up to 19 different types of saw blades: 8 of which can be up to 185mm in diameter, 9 of which can be up to 250mm and 2 up to 350mm in diameter.

The standard composition of the display cabinet contains 15 different types of blades for the most popular machines.

Dimensions are in cm.

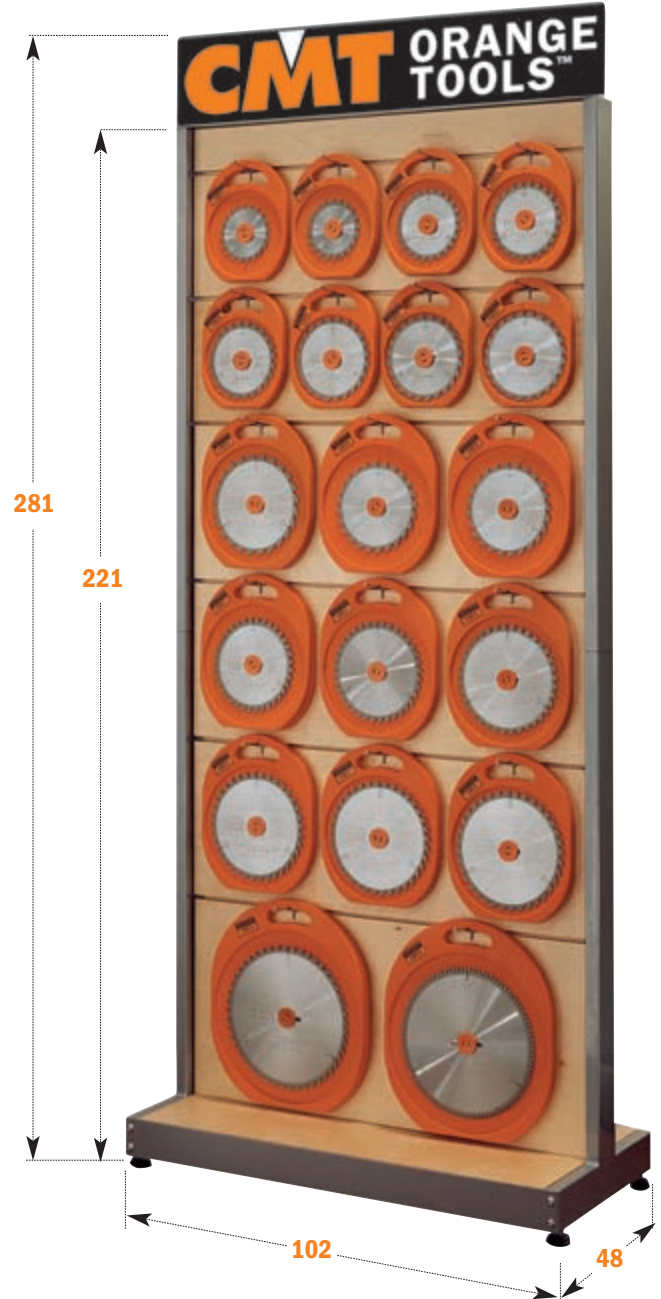

**200.072.00**

Order no.	Description		Q.tà
291.125.20H	Saw blade 125x2.4x20	Z=20	2
291.130.20H	Saw blade 130x2.4x20	Z=20	2
291.140.20H	Saw blade 140x2.4x20	Z=20	2
291.150.24H	Saw blade 150x2.4x20	Z=24	2
291.150.24E	Saw blade 150x2.4x16	Z=24	2
291.160.24E	Saw blade 160x2.6x16	Z=24	2
291.160.24H	Saw blade 160x2.6x20	Z=24	2
292.160.40H	Saw blade 160x2.6x20	Z=40	2
291.170.24M	Saw blade 170x2.6x30	Z=24	2
291.180.24H	Saw blade 180x2.6x20	Z=24	2
291.180.24M	Saw blade 180x2.6x30	Z=24	2
291.184.24E	Saw blade 184x2.6x16	Z=24	2
291.190.24E	Saw blade 190x2.6x16	Z=24	2
291.190.24H	Saw blade 190x2.6x20	Z=24	2
291.190.24M	Saw blade 190x2.6x30	Z=24	2
292.190.40M	Saw blade 190x2.6x30	Z=40	2
291.200.36M	Saw blade 200x2.8x30	Z=36	2
291.210.36L	Saw blade 210x2.8x25	Z=36	2
291.210.36M	Saw blade 210x2.8x30	Z=36	2
290.216.24M	Saw blade 216x2.8x30	Z=24	2
291.216.48M	Saw blade 216x2.8x30	Z=48	2
292.216.64M	Saw blade 216x2.8x30	Z=64	2
291.220.36M	Saw blade 220x2.8x30	Z=36	2
291.230.36M	Saw blade 230x2.8x30	Z=36	2
291.235.36L	Saw blade 235x2.8x25	Z=36	2
291.235.36M	Saw blade 235x2.8x30	Z=36	2
291.240.36M	Saw blade 240x2.8x30	Z=36	2
285.040.10M	Saw blade 250x3.2x30	Z=40	2
285.060.10M	Saw blade 250x3.2x30	Z=60	2
285.080.10M	Saw blade 250x3.2x30	Z=80	2
285.048.12M	Saw blade 300x3.2x30	Z=80	2
285.054.14M	Saw blade 350x3.5x30	Z=54	2
297.064.09M	Saw blade 216x2.8x30	Z=64	2
297.080.10M	Saw blade 250x3.2x30	Z=80	2
297.096.12M	Saw blade 300x3.2x30	Z=96	2
297.108.14M	Saw blade 350x3.5x30	Z=108	2

DESCRIPTION	ORDER NO.
Display cabinet (big) with: 72 HW saw blades	<b>200.072.00</b>
Display cabinet only (big)	<b>03.00.0027</b>
Wire counter display only (small)	<b>03.00.0030</b>

CMT has selected the 24 most popular profiles for professional woodworkers.

The display contains all the most popular profiles to make junctions, joints, frames, kitchen doors, etc.

The display is supplied with 5 cutter heads in plastic boxes, 48 couples of profiled knives and 24 couples of relative limitors.

For use in all brands and models of moulder and spindle moulder machines for professional and beginner woodworkers for all kinds of wood.

Dimensions are in cm.



**600.149.00**

Order no.	Description		Q. tà
692.078.30	Cutter head without limitors	D= 78mm F=30mm	1
692.100.30	Cutter head without limitors	D=100mm F=30mm	1
692.100.35	Cutter head without limitors	D=100mm F=35mm	1
693.100.30	Cutter head with limitors	D=100mm F=30mm	1
693.100.35	Cutter head with limitors	D=100mm F=35mm	1
690.000	Pair of knives l=40mm Sp=4mm		2
690.001	Pair of knives l=40mm Sp=4mm		2
690.002	Pair of knives l=40mm Sp=4mm		2
690.003	Pair of knives l=40mm Sp=4mm		2
690.004	Pair of knives l=40mm Sp=4mm		2
690.005	Pair of knives l=40mm Sp=4mm		2
690.008	Pair of knives l=40mm Sp=4mm		2
690.011	Pair of knives l=40mm Sp=4mm		2
690.014	Pair of knives l=40mm Sp=4mm		2
690.015	Pair of knives l=40mm Sp=4mm		2
690.016	Pair of knives l=40mm Sp=4mm		2
690.017	Pair of knives l=40mm Sp=4mm		2
690.019	Pair of knives l=40mm Sp=4mm		2
690.021	Pair of knives l=40mm Sp=4mm		2
690.029	Pair of knives l=40mm Sp=4mm		2
690.042	Pair of knives l=40mm Sp=4mm		2
690.052	Pair of knives l=40mm Sp=4mm		2
690.089	Pair of knives l=40mm Sp=4mm		2
690.096	Pair of knives l=40mm Sp=4mm		2
690.097	Pair of knives l=40mm Sp=4mm		2
690.098	Pair of knives l=40mm Sp=4mm		2
690.099	Pair of knives l=40mm Sp=4mm		2
690.100	Pair of knives l=40mm Sp=4mm		2
690.106	Pair of knives l=40mm Sp=4mm		2
691.000	Pair of limitors l=40mm Sp=4mm		1
691.001	Pair of limitors l=40mm Sp=4mm		1
691.002	Pair of limitors l=40mm Sp=4mm		1
691.003	Pair of limitors l=40mm Sp=4mm		1
691.004	Pair of limitors l=40mm Sp=4mm		1
691.005	Pair of limitors l=40mm Sp=4mm		1
691.008	Pair of limitors l=40mm Sp=4mm		1
691.011	Pair of limitors l=40mm Sp=4mm		1
691.014	Pair of limitors l=40mm Sp=4mm		1
691.015	Pair of limitors l=40mm Sp=4mm		1
691.016	Pair of limitors l=40mm Sp=4mm		1
691.017	Pair of limitors l=40mm Sp=4mm		1
691.019	Pair of limitors l=40mm Sp=4mm		1
691.021	Pair of limitors l=40mm Sp=4mm		1
691.029	Pair of limitors l=40mm Sp=4mm		1
691.042	Pair of limitors l=40mm Sp=4mm		1
691.052	Pair of limitors l=40mm Sp=4mm		1
691.089	Pair of limitors l=40mm Sp=4mm		1
691.096	Pair of limitors l=40mm Sp=4mm		1
691.097	Pair of limitors l=40mm Sp=4mm		1
691.098	Pair of limitors l=40mm Sp=4mm		1
691.099	Pair of limitors l=40mm Sp=4mm		1
691.100	Pair of limitors l=40mm Sp=4mm		1
691.106	Pair of limitors l=40mm Sp=4mm		1

## DESCRIPTION

## ORDER NO.

Display cabinet with: 5 cutter heads, 48 pairs of knives (l=40mm), 24 pairs of limitors (l=40mm)

**600.149.00**

Display cabinet only

**03.00.0000**



Start your stock of CMT drill and boring bits now and receive a 50 drawer super cabinet or a 15 drawer small cabinet to help you get organized. Each drawer has the capacity to contain more than 10 pieces. Always have what you need on hand right when you need it. Your customers will benefit from the easy access and visibility of the selection. Contact our office for terms and to choose the drill and boring bits you want from our vast range.

Dimensions are in cm.

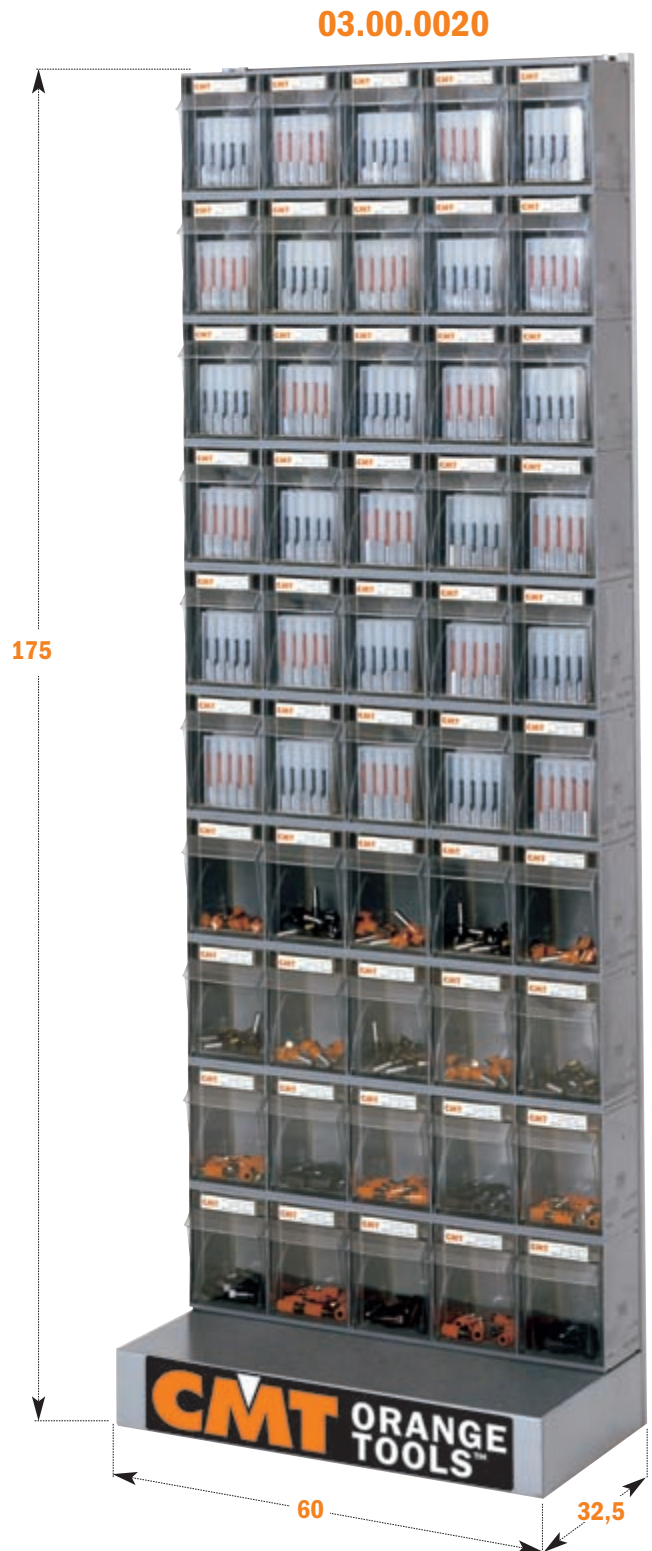

DESCRIPTION	ORDER NO.
Display cabinet for drill bits, 15 drawers	03.00.0019
Display cabinet for drill bits, 50 drawers	03.00.0020



DESCRIPTION	PAGE
12 piece set with wooden case	39
13 piece cutter head multiprofile set	139
13 piece dovetail and straight bit sets	38
13 piece set with wooden case	39
15 piece router bit set	35
26 piece router bit set	35
3 piece adjustable grooving set	125
3 piece kitchen set	43
5 piece boring bit set for hinges	194-195
5 piece profile bit set	36
5 piece spiral bit set	37
5 piece straight bit set	36
6 piece mortising bit set	239
6 piece profile bit set with wooden case	39
7 piece cutter head multiprofile set with limitors	140
8 piece dovetail and straight bit sets	38

## A

Adaptors & bushings for twist drills	252
Adaptors	192-193 - 244~246
Adjustable countersink	206
Adjustable rounding & chamfering set	127
Adjustable scoring blades	167

## B

Beading bits	80
Bevel cutters for Corian®	75
Bilance blades & sanding disk	183
Biscuits joiner blades	181
Bore reducers	150
Boring bit and plug cutter sets	199
Boring bits with parallel shank	194-195
Boring bits with parallel shank	196-197
Boring bits with parallel shank	47
Bowl and tray bits	72
Brad point bit sets	203
Brad point bits	202
Brad point bits	204
Brad point bits	206

## C

Cap nut for CNC machines	212-213
Cavetto edge mold bits	76
Chamfer bits with knives	120
Chamfer bits	75, 77
Chamfer set	77
Chamfer (45°)	126
Chuck with precision collet "ER32"	212
Classical bead bits	88
Classical ogee bits	82-83
CMT inlay kit	32
CMT molding system	90
CMT professional router table system	18
CMT router table	20
CMT-Enlock joining system	21
CMT's complete kitchen set	42
Collet chuck clamp with MK2 tapered shank	217
Combination flush and bevel trim bits	67
Combination trimmer bits	67
Complete set for MDF doors	228-229
Compound miter saw with upper table	14-15
Conical scorino blades	167
Corner beading bits	81
Countersink for 2 flutes dowel drills	261
Countersink for 4 flutes dowel drills	260
Countersink	207
Cove bit set	78
Cove bits	78
Crosscut and finishing saw blades	162
Crosscut saw blades	177
Cutter heads with limitors	138
Cutter heads without limitors	138

## D

Dado & planer bits	57
Decorative ogee bits	88
Diamone whetstone	30-31
Display cabinet	270-271

DESCRIPTION	PAGE
Display cabinets for cutter head and knives	274
Display cabinets for drill bits	275
Double-bearing spiral flush trim bits	65
Dovetail bits	58-59
Dovetail cutters (9°)	208
Dowel drill for Mafell®	47
Dowel drill for through holes	251
Dowel drill	249
Dowel drills for Mafell®	205
Dowel drills with countersink	259
Dowel drills with threaded shank	266-267
DP router cutters with shear angle	227
DP saw blade for ultra-hard materials	178
Drawer lock bits	95
Drill bits for Anuba hinges	203
Dry cut saw blades	172

## E

Ellipse & circe cutting jig	24
Entry & interior door router bit set	40

## F

Fine cut off saw blade for melamine two-sided	164
Fine cut off saw blades for melamine two-sided	166
Fine cut off saw blades for melamine	165
Fine cut off saw blades	178
Fine finishing saw blades	163
Finger joint bit	98
Finger pull bit	101
Flute dowel drills for through holes	262-263
Flute dowel drills	254-255
Flush and V-groove bits	66
Flush trim bits for laminates	64
Flush trim bits with knives	119
Flush trim bit for laminates	65
Flute dowel drills for through holes	263
Flute dowel drills	256~258
Flush trim bits	63
Flute & bead set	92
Formula 2050	34
Forstner bit sets	201
Forstner bits	200

## G

Garden trimmer saw blades	176
Grinding wheels for Xtreme sharpening	250
Grooving cutters	234-235
Grooving saw blades	180

## H

Hand planer (82mm)	16
Hinge boring bits	264-265
Hinge recesser bits	57
HS 5%co spiral bit for aluminium	230
HS Corrugated back moulder knives	151
HSK chuck with precision collet "ER40"	214
HWM Reversibile knives for portable planers	153
HWM Reversibile knives	154-155

## I

Index for saw blades	186~190
Industrio™ routing system	19
ISO30 chuck with precision collet "DIN6388"	216
ISO30 chuck with precision collet "ER32"	211
ISO30 chuck with precision collet "ER40"	213

## J

Junior ogee rail and stile set	107
--------------------------------	-----

## K

Keyhole and T-slot bits	69
Kitchen worktop jig	25

## L

Laminated and chipboard saw blades	165
------------------------------------	-----

DESCRIPTION	PAGE
Laminated and chipboard saw blades	166
Laser point bit (60°)	71
Lettering bit (60°)	72
Lock miter bits	96
Lock miter set	97
Lock miter (45°)	133
Lonnie Bird's divided light door set	41
Lonnie Bird's rail and stile set	107
Lonnie Bird's small arch door set	45

## M

Magnetic knife setting jigs	151
Mini-spot circular blade for lamello	181
Molding bits "Lonnie Bird's"	86
Molding bits	89
Mortise chisel & bit sets	208
Mortising bits	56
Multiprofile bits	91
Multiradius roundover	128
Multiradius roundover	129
Multi-rip saw blades with rakers	160
Multi-rip saw blades	160

## N

Non-Ferrous metal and laminated panels saw blades	171
Non-Ferrous metal and plastic material saw blades	170

## O

Ogee bits	81
Ogee bits	85
Ogee with fillet bits	84
One piece rail & stile	135
Organizer	34
Ovolo bits	76

## P

Panel pilot bits with guide	66
Panel sizing and scoring blades	168
Panel sizing saw blades	169
Part and accessories	110~113
Pattern bits with knives	117
Pattern bits with knives	118
Pattern bits	55
Planer and jointer knives	152
Plexiglass and plastic blades	173
Plug cutters	198
Plunge ogee bits	87
Plywood groove set	50
Pocket-Pro™ joinery system	32
Precision balanced chucks	210
Precision collets	215
Precision dado	182
Professional finger joint bit	99
Professional finger joint	131
Professional raised panel	134
Profile knives and limitors	141~149
Profiles and counter profiles set	136-137

## R

Rabbeting bits with knives	121
Rabbeting bits	73
Rabbeting cutter head	124
Rabbeting sets	73
Rail & stile sets	108
Raised panel bit with back cutter	105
Raised panel bits	106
Reciprocating slot mortising bits	240-241
Reduction rings for saw blades	183
Reverse glue joint bits	94
Reverse glue joint	132
Ripping saw blades	161, 176
Roman ogee bits	82
Round nose bits	68
Round nose set	69
Roundover and cove	130
Roundover bits with knives	122
Roundover bits	79

DESCRIPTION	PAGE
Roundover set	80
Router 2000W	17
Router bit set with knives	37
Router bits display cabinets	272
Router bits for Domino® Joining machine by Festool®	205
Router cutters with knives	225
Router cutters	231~233

## S

Saw blade display cabinets	273
Saw blades for building contractors	161
Saw blades for building contractors	182
Saw blades for portable machines	184-185
Saw blades stabilizer	183
Screw slot bits	71
Slot and mortise boring bits	236-237
Slot cutter arbors	60
Slot cutter set	46
Slot cutter with arbor and bearing	60
Slot cutters	61
Slot mortising bits with chipbreaker	238
Slot mortising bits	242
Solid carbide dowel drills for through holes	250
Solid carbide dowel drills	248
Solid carbide spiral bit	48-49
Solid carbide spiral bits	218-224
Solid carbide twist drills	253
Solid surface blades	173
Special dowel drills	268
Spoilboard surfacing router cutters	225
Step-by-step window sash construction	103
Straight bits	50~53
Straight router bits with knives for laminated	116-117
Straight router bits with knives	116
Straight router bits with knives	118
Straight router cutters with knives	226
Super finishing saw blade for frames cut	163
Super-duty flush trim bits	64

## T

Table edge and hand rail bits	92
Tenon cutting router	40
The ABC's of panel door construction	109
The cabinetmaking set	44
The CMT grand rabbet set	74
The glass panel set	41
The junior raised panel set	45
Thick kerf multi-rip saw blades with rakers	159
Thin kerf multi-rip saw blades with rakers	159
Three wing slot cutter set	62
Tongue and groove set	62
Twisted slot mortising bits with chipbreak	239

## U

Ultra Industrial Thin-kerf blades	174
Ultra Thin-kerf and crosscut blades	174
Ultra Thin-kerf fine compound miter blades	175
Ultra Thin-kerf fine finish blades	175
Ultra Thin-kerf saw blades	179
Universal boring jig	29
Universal boring template	28
Universal dovetail jig	22-23
Universal hinges boring system	26-27

## V

Vertical raised panel bits	104
V-Groove - folding - signmaking CNC router cutters	226
V-Grooving bits (90°) for plasterboard	70
V-Grooving bits (90°)	70
V-Tongue and groove set	100

## W

Weatherseal bits	54
Window sash set	102
Window sill and finger pull bits	93

ORDER NO.	PAGE	ORDER NO.	PAGE	ORDER NO.	PAGE	ORDER NO.	PAGE	ORDER NO.	PAGE
01.02	250	191.000.02	37	308	257	513	196-197	700.351.00	270-271
03.00.0000	272, 274	191.143/163	224	309	257	514	197	701-701B	56
03.00.0019	275	191.635	54	310	254	515	203	702	57
03.00.0020	275	191B	65	310.21/22	248	516	206	703	75
03.00.0025	270	192	48-49, 223	310.41/42	249	517	202-203	704	75
03.00.0027	273	192.000.01	37	311	255	521	207	705	75
03.00.0030	273	192.000.02	37	311.21/22	248	521.001	206	706	63-64
03.51	34	192B	65	311.41/42	249	522	208	707	65, 67
102	238-239	193	221	312	47, 205	523	208	709	67
103	241	194	221	313	262	529	198	710	67
104	240	195	220, 224	313.41/42	251	530	198	711	50-51
105	240	195.143/163	224	314	262	532	192	711.031	54
106	242	196	220	314.21/22	250	533	192	711B	55
107	242	197	219	314.41/42	251	534	193	712	52, 54
112	232	198	218	315	261	535	204	712B	55
113	232	200.030.00	270-271	316	260	537	200-201	713.001.11	54
123	217	200.072.00	273	317	264	540	204	714-714B	68
124	217	210	164	325	266	541	111, 204	715-715B	70
136	234	222	173	327	266	542	204	716	66
140	227	223	173	329	266	543	208	716.061	66
141	227	226	172, 179	330	266	600.005.01	37	718-718B	58-59
160	239	230	182	338	266	600.149.00	274	721	67
161	239	236	179	339	266	615.004.01	228-229	722A	61
163	236	240	180-181	340	266	651	116	724	60
164	236	240.004.04	181	344	267	652	116-117	724.xxx.00-10	61
166-167	237	241	181	346	267	652B	116	727	76
169	237	250	182	350	207	653	118, 226	735	73
170	235	251	182	351	207	654	118	735.001	73
171-180-181	235	271	174, 179	352	267	655	118	736	77
172	238-239	272	175, 179	353	267	656	117	737	78
173-182	234	273	175	358	245	657	119	738	79
174	53, 231	277	159	359	246	658	120	739	80
175	233	278	160	360.001	246	659	120	740	82
176	233	279	160	360.101	246	660	120	741	82
177	53, 233	280	159	361	254	660.9	121	744	83
179	241	281	165-166, 169	362	255	661	122	745	83
183.000/100	212	282	169	363	253	662	225	746	84
183.200	211	283	164	364	252	663.001.11	225	747	84
183.201	213	284	170	365	252	663.101.11	226	748	87
183.210	211	285	161~163	366	262	690-691	141~149	748B	87
183.211	213	286	161	367	263	692	138-139	749	72
183.220	211	287	166	368	263	693	138, 140	750.001	69
183.221	213	288	166	369	264	694.001	125	751-751B	72
183.250	211	289	166	369	265	694.002	126	753	66
183.251	211	290	161	370	265	694.003	128	754	81
183.255	216	290	176	372	258	694.004	129	755.002	95
183.260	210	291	162, 177	373	258	694.005	127	758	71
183.300	210	292	178	374	263	694.007	130	759	85
183.310	214	293	161	375	263	694.008	131	760	85
183.360	210	294	162	376	259	694.009	132	761	81
183.400	212	296	171	377	259	694.011	133	763	76
184	113	297	171	380	205	694.013	134	764	76
184.000	215	298	176	391	47	694.014	135	765.001	88
184.002	215	299	183	391	196	694.015	136-137	765.101	88
184.xxx.20	214	299.10	183	500.001	199	694.100	124	765.102	88
184.xxx.25	215	299.11	183	500.002	199	699	150	765.201B	88
185	216	301	244	500.003	199	700.001.00	35	765.301B	88
188	230	302	244	501	193	700.003.00	35	765.402	88
189	230	303	244	503	193	700.005.01	36	790	153~155
190	48, 219	304	245	506	192	700.005.02	36	791	110
190B	65	305	245	509	192	700.005.03	36	792	152
191	48-49, 222	306	256	511	192	700.084.00	272	793	151
191.000.01	37	307	256	512	194-195	700.300.00L	270-271	796	112

ORDER NO.	PAGE	ORDER NO.	PAGE	ORDER NO.	PAGE	ORDER NO.	PAGE	ORDER NO.	PAGE
796.001	113	827	76	865.101	88	923.001.11	46	965.202B	88
796.500/600	112	835	73-74	865.102	88	923A	60	965.303B	88
796.780	111	835.001	73	865.201B	88	924	60	965.402	88
796.8	111	835.503	74	865.301B	88	924.xxx.00-10	61	966.5	75
797	112	836	77	866.5	75	927	76	966.6	75
798	113	836.501.11	77	866.6	75	935	73-74	967.5B	86
799	111	837	78	867.5B	86	935.001	73	967.6B	86
800.001.00	35	837.001.11	78	867.6B	86	935.503	74	990	105
800.005.01	36	838	79	890	105	936	77	990	110
800.500	38	838.001.11	80	890.5	106	937	78	990	122
800.501	38	838.501.11	80	890.6	104	937.001.11	78	990.422/423	110
800.503	39	839	80	891.5	108	938	79	990.5	106
800.504	39	840	82	891.512	107	939	80	990.6	104
800.505	39	841	82	891.517	107	940	82	991	110
800.506	62	842	67	891.521	109	941	82	991	122
800.509	42	843	67	899	32	944	83	991.123	217
800.510	42	844	83	900.001.00	35	945	83	991.183	212
800.511	42	845	83	900.003.00	35	946	84	991.283	214
800.512	43	846	84	900.005.01	36	947	84	991.283	216
800.513	43	847	84	900.005.02	36	948	87	991.5	108
800.514	43	848	87	900.005.03	36	948B	87	991.512	107
800.515	44	848B	87	900.021.00	270-271	949	72	991.517	107
800.516	43	849	72	900.024.11	45	949B	72	991.521	109
800.517	44	849B	72	900.025.11	41	950.001	69	992.123	217
800.518	45	850.001	69	900.084.00	272	950.601	69	992.183	212
800.519	38	850.601	69	900.300.00L	270-271	950.602	69	992.283	216
800.520	44	850.602	69	900.351.00	270-271	950.603	69	992.383	214
800.521	44	850.603	69	900.506	62	951	72	993.0	213
800.522	45	851-851B	72	900.509	42	953	66	993.5	213
800.524	45	852-852B	57	900.510	42	954	81	998.001.01	34
800.525	41	853	66	900.511	42	955	97	998.001.03	34
800.527	40	854	81	900.512	43	955.002	95	999.100.00	18
800.606	99	855	97	900.513	43	955.501	94	999.100.11	19
800.616	98	855.002	95	900.514	43	955.502	95	999.200.00	20
800.626	62	855.501	94	900.516	43	955.503	96	999.500.01	19
800.627	40	855.502	95	900.517	44	955.504	96	999.501.11	19
801-801B	56	855.503	96	900.518	45	955.506	100	CMT2E	17
806	63-64	855.504	96	900.521	44	955.601	101	CMT2E-B	17
806.001.11	63	855.506	100	900.522	45	955.701	92	CMT2E-B+999.500	19
807	65	855.601	101	900.606	99	955.802	102	CMT3	16
811	50-51	855.701	92	900.616	98	955.803.11	41	CMT300	22-23
811.001.11	50	855.801	102	900.626	62	955.804	93	CMT3000	24
811.501.11	50	855.803.11	41	901-901B	56	955.804B	93	CMT333	26-27
811B	55	855.804	93	902	57	955.805	93	CMT4	14
812	52, 54	855.804B	93	903	75	955.805B	93	CMT400	29
812B	55	855.805	93	904	75	955.901	89	CMT5	15
813.001.11	54	855.805B	93	905	75	955.902	89	CMT650	25
813.601	71	855.901	89	906	63-64	956.501	89	CMT656	29
813.701	71	855.902	89	907	65, 67	956.601	92	CMT792	151
814.001.11	69	856.501	89	909	67	956.701	92	CMT900	28
814.501.11	69	856.601	92	910	67	956.8	91	CMT-Enlock1	21
814-814B	68	856.701	92	911	50-51	956.851	90	DSS	30-31
815-815B	70	856.8	91	911B	55	956.852	90	PPJ-001	33
816	66	856.851	90	912	52	957	77	PPJ-002	33
818-818B	58-59	856.852	90	912B	55	958	71		
821	67	857	77	913.101	71	959	85		
822	61	858	71	913.201	71	960	85		
822A-B	61	859	85	914-914B	68	961	81		
823	60	860	85	915-915B	70	963	76		
823.001.11	46	861	81	916	66	964	76		
823B	60	863	76	918	58-59	965.001	88		
824	60	864	76	921	67	965.101	88		
824.xxx.00-10	61	865.001	88	922A-B	61	965.102	88		



## PREMISE

**C.M.T.** products are the result of technological innovation achieved through continuous research applied on a vast scale. Drawings, technical data, photos of the products and packaging are supplied for the sole purpose of informing the customer and are not binding in any manner. **C.M.T.** may undertake, when necessary, modifications and improvements without applying these innovations to the parts already supplied. The operational tolerances conform to technical standards that are acceptable for this range of tools.

## ACCEPTANCE OF THE CONTRACT

All orders for our products are meant to be accepted at the price and sale conditions that are legally in force at the date of delivery. Every order will be treated and supplied according to the following general sale conditions. By placing an order or accepting an offer, the customer accepts, without any reservations, all conditions expressly mentioned hereafter. Any other derogation will only be accepted upon written consent by **C.M.T.** All other cases not contained within these conditions will fall under the Italian Civil Code. Offers and order confirmations will be processed according to stock availability. Any order, even those taken by our representative agents, will be subject to our acceptance, which could also be a partial one. We will notify the acceptance of any order by an order confirmation in which we will indicate all details pertaining to the items purchased, their price and expected delivery date. Therefore, we will not be able to accept any modification after three working days from the date of receipt.

## MINIMUM AMOUNT ACCEPTABLE

**C.M.T.** will only be able to accept and process orders for a minimum net amount of € 100,00. In case of acceptance of the order, we will add € 15,00 for shipping and handling.

## PRICES

The prices stated in **C.M.T.'s** quotation and price lists are gross and are intended to be "ex-works". Prices and VAT will be those in force at the date of shipping. To the best of our knowledge, the prices indicated in our catalogues, price lists and order confirmations are correct. However, **C.M.T.** cannot be held legally liable for reserving the right to change prices without notification in line with the manufacturer's cost increases.

## DELIVERY

Delivery dates in the order confirmation are given as an indication of the estimated delivery time. They have to be considered as reliable only in case of normal operating conditions, and there shall be no liability on the part of the Seller for any failure to deliver due to causes beyond the Seller's control. **C.M.T.** will also not be able to accept any cancellation of existing orders which were not delivered in time due to external impediments. Standard products will be shipped within five working days from receipt of the order.

## SHIPPING AND HANDLING

The packing of our products will be charged on the final invoice, while shipping is "ex-works" from our factory at Chiusa di Ginestreto (Pesaro). All products supplied by **C.M.T.** travel at the customer's own risk. **C.M.T.** retains the right to charge freight costs on the invoice in case of value under the minimum amount acceptable of €100,00. **C.M.T.** will not be held responsible for any damage, theft or tampering that might occur during transport, and for which the forwarder will be legally liable according to article 1693 of the Civil Code. The customer, for his part, will have to check the goods at the moment of receipt and, in case any anomaly or damage is found, he will have to apply for a refund to be addressed to the forwarder.

## PAYMENT

Cash payments can only be accepted for purchases done directly at the **C.M.T.** factory located in Chiusa di Ginestreto (Pesaro) in accordance with article 1182, sub-section 3 of the Civil Code, or upon delivery of the goods provided there is a written agreement between the parties. Deferred methods of payment will have to be previously agreed with the Seller. In this case, if one or more instalments are not paid, the agreement will automatically expire according to article 1186 of the Civil Code. A delay in payment, even partial, will automatically incur interest in the amount of an extra 5% to be charged to the customer's account. In case of non payment, **C.M.T.** reserves the right to suspend any further supply of its products.

## WARRANTY

All professional tools by **C.M.T.** are manufactured according to high standards of technology and are therefore warranted against any possible defect. This warranty does not cover damage or tampering which can be ascribed to inappropriate use. It is also not applicable for tools that have been re-sharpened. This warranty does not cover the possible injuries resulting from inappropriate use of defective tools. **C.M.T.** will repair or replace any goods which the buyer shall prove to have been defective in material or workmanship upon analysis by its technical department. Any complaint must be communicated within fifteen days from receipt of the goods together with a written form in which the customer provides a detailed description of the defect. Any return of tools will only be accepted upon authorisation by **C.M.T.** and the freight will be at the customer's own expense.

## OWNERSHIP RIGHTS

All rights are reserved in accordance with Italian law and with international agreements, and the whole or any part of this catalogue may not be reproduced in any way or form.

## PLACE OF JURISDICTION

For any legal matter the place of jurisdiction is Pesaro. All contracts, even those made with foreign Buyers or for goods to be sent abroad, are regulated by Italian legislation.

TM: CMT, the CMT logo and the orange color applied to tool surfaces are trademarks of C.M.T. UTENSILI S.P.A.

© 2008 C.M.T. UTENSILI S.P.A.

This document has been sent for your personal use only. All usage and reproduction is forbidden without written permission from C.M.T. UTENSILI S.P.A.



Power tools



Accessories



Router bits



R. b. w/replaceable knives



Cutter heads & knives

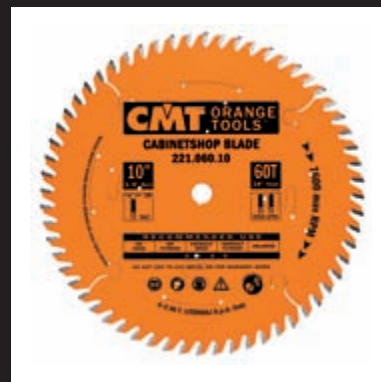

Saw blades



Boring bits



Router cutters & Chucks

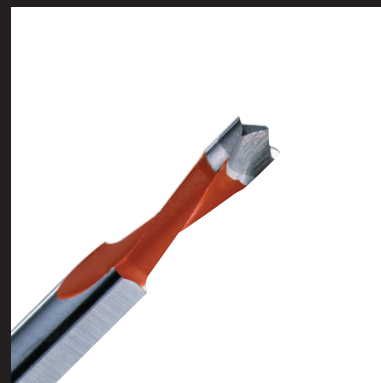

Dowel drills

## **C.M.T. UTENSILI S.p.A.**

Via della Meccanica  
61020 Chiusa di Ginestreto  
Pesaro - Italia

Phone #39 0721 48571

Fax #39 0721 481021

e-mail [info@cmtutensili.com](mailto:info@cmtutensili.com)

[www.cmtutensili.com](http://www.cmtutensili.com)

ORDER NO. 03.60.3006



8 019296 020434