

VICTORIAN

Scrollsaw Music Boxes



Create 58 Heirloom Quality Keepsakes
Rick & Karen Longabaugh



Project #1

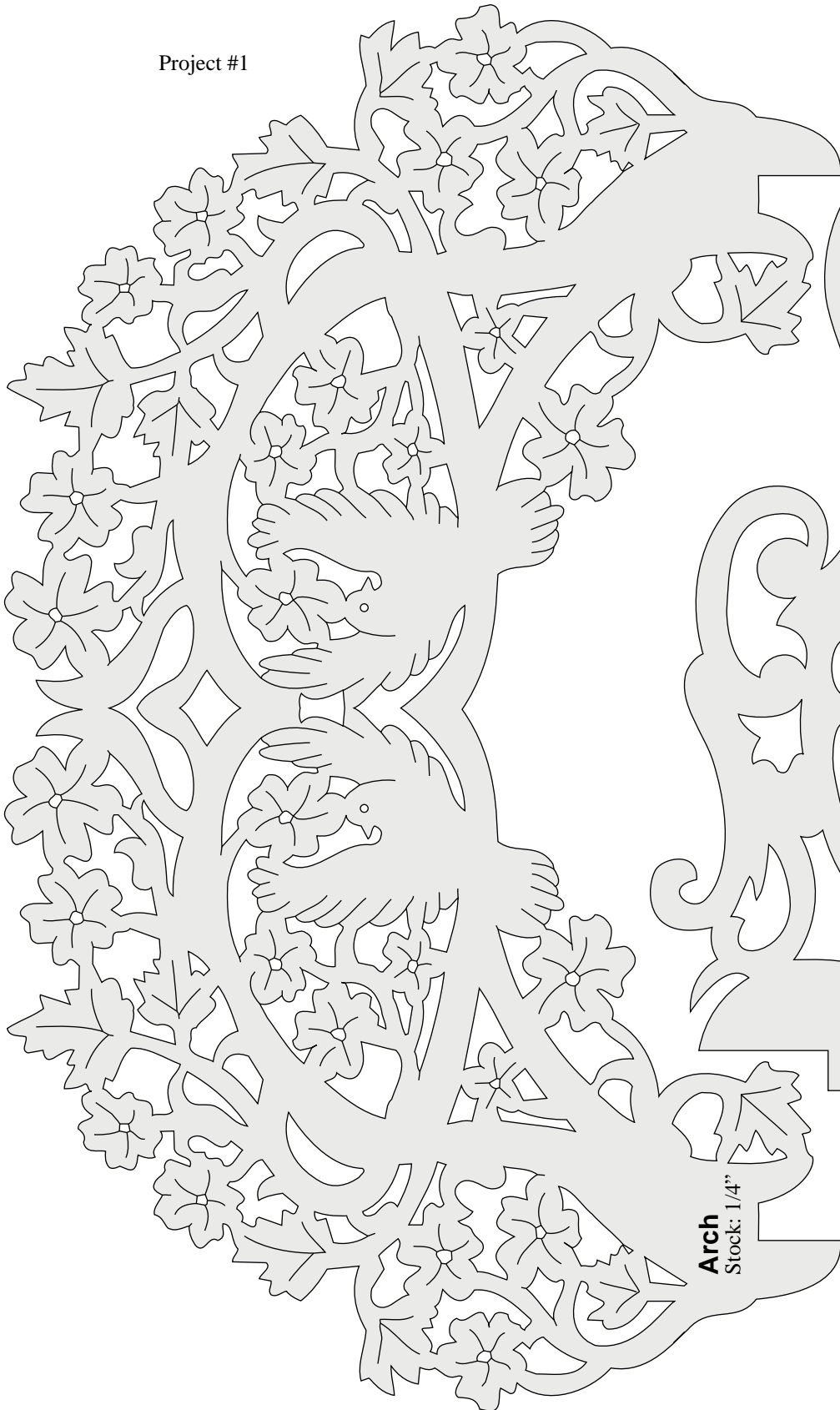

Arch
Stock: 1/4"

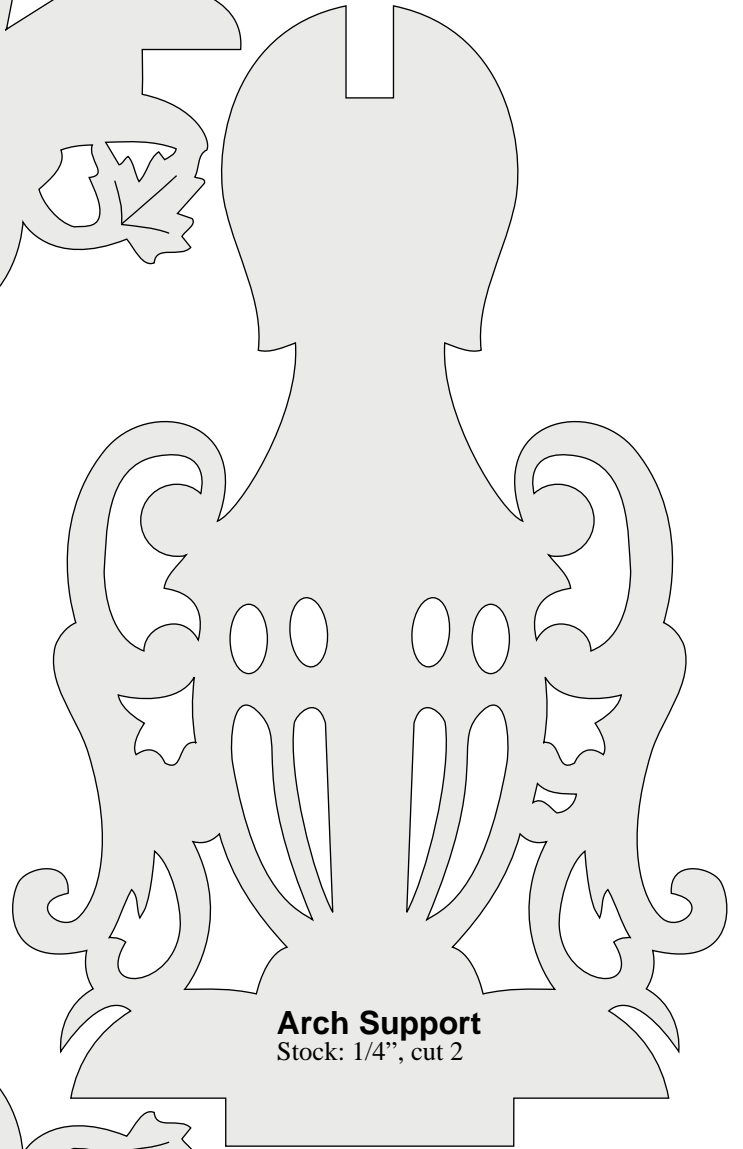

Arch Support
Stock: 1/4", cut 2

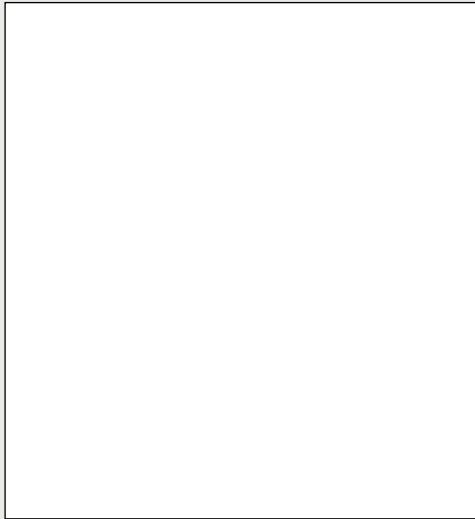
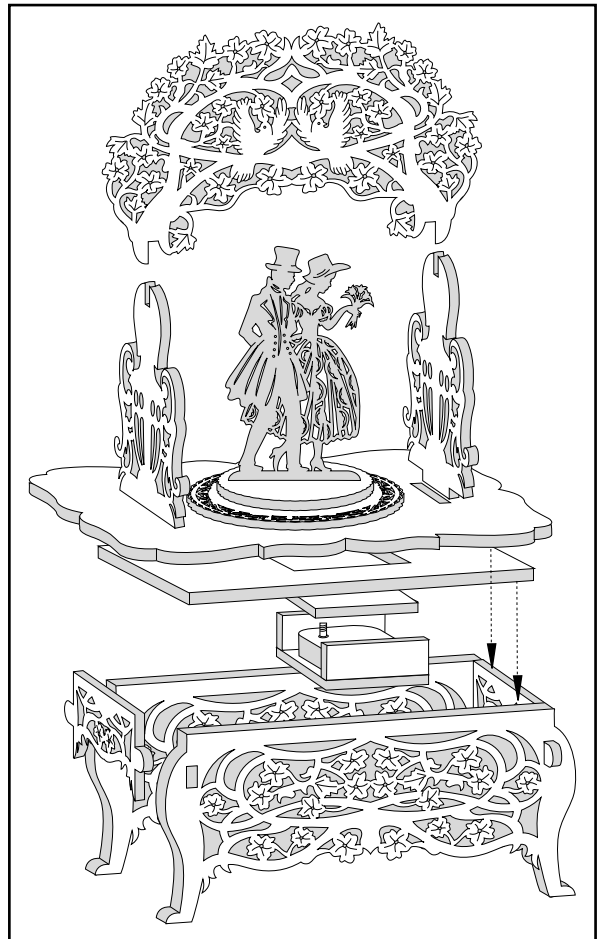

Base Support
Stock: 1/4"

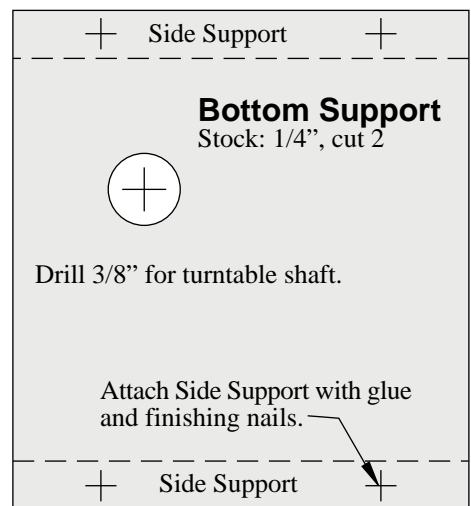
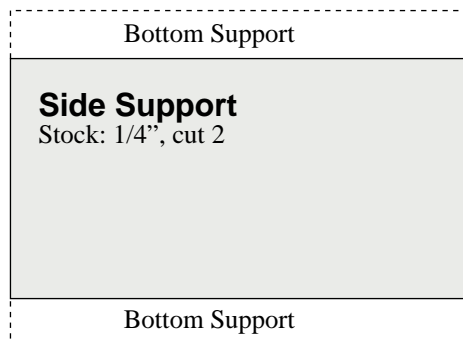

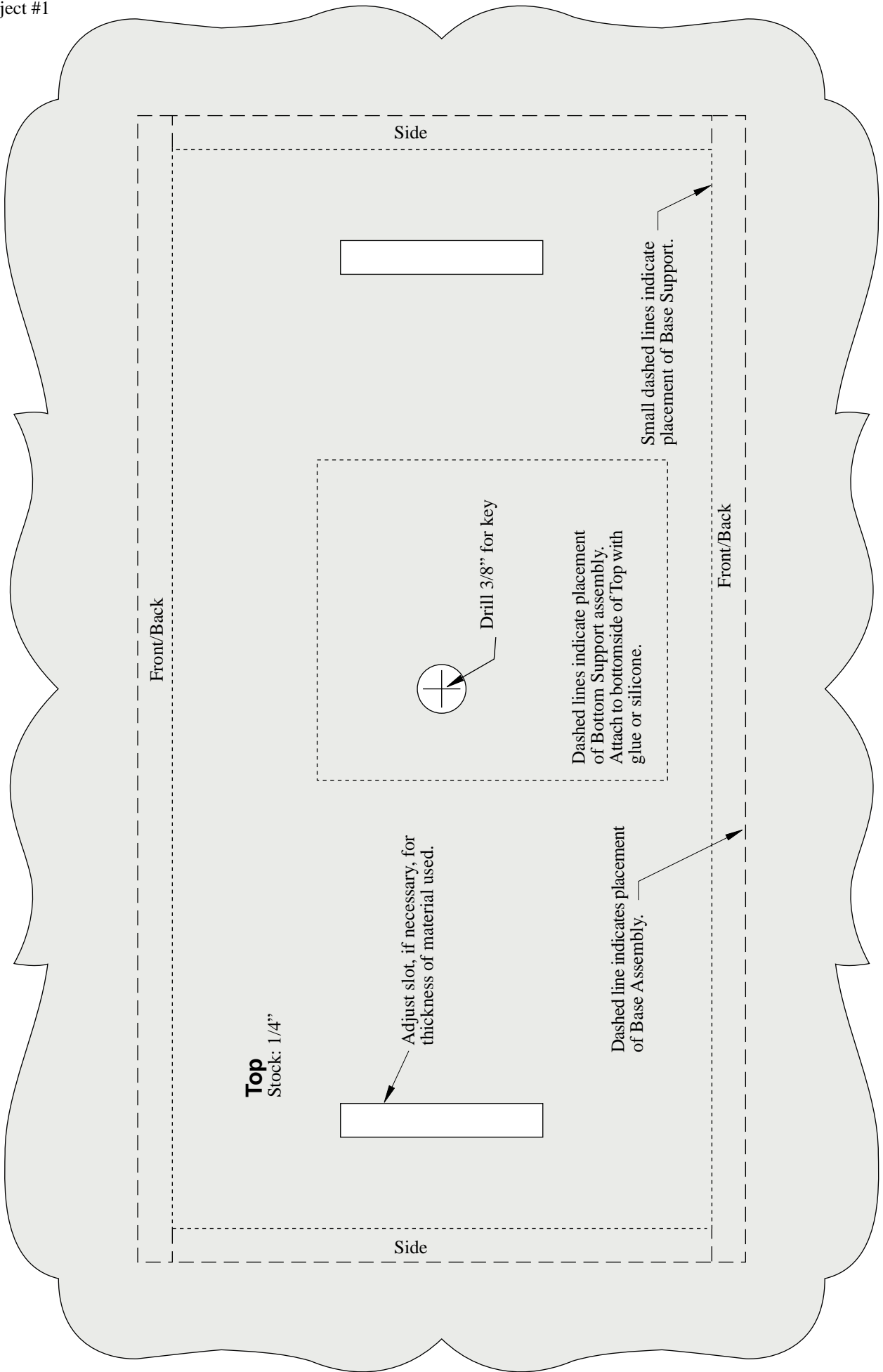

Turntable

Stock: 1/4", countersink the bottomside with a 1" forstner bit 1/16" deep. Secure the metal turntable with super glue or silicone.

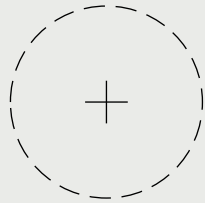

Dashed line indicates placement of Turntable Overlay.

Turntable Overlay

Stock: 1/4", Secure to the Turntable with glue or silicone.

Adjust slot if necessary for thickness of material used.



Side

Stock: 1/4", cut 2

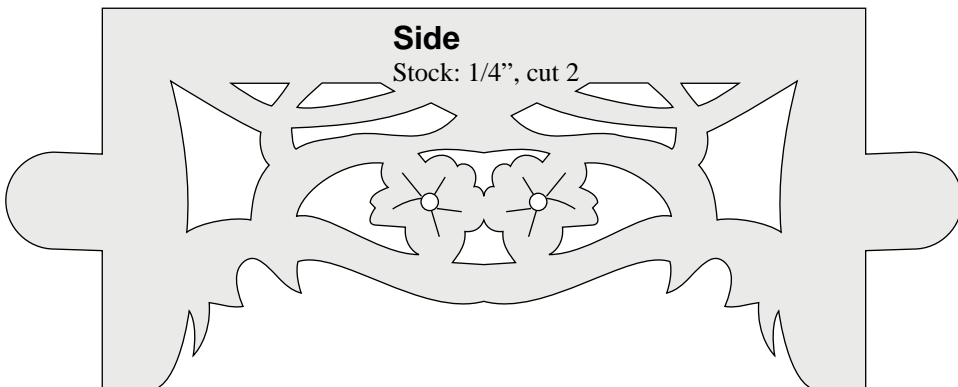

Project #1

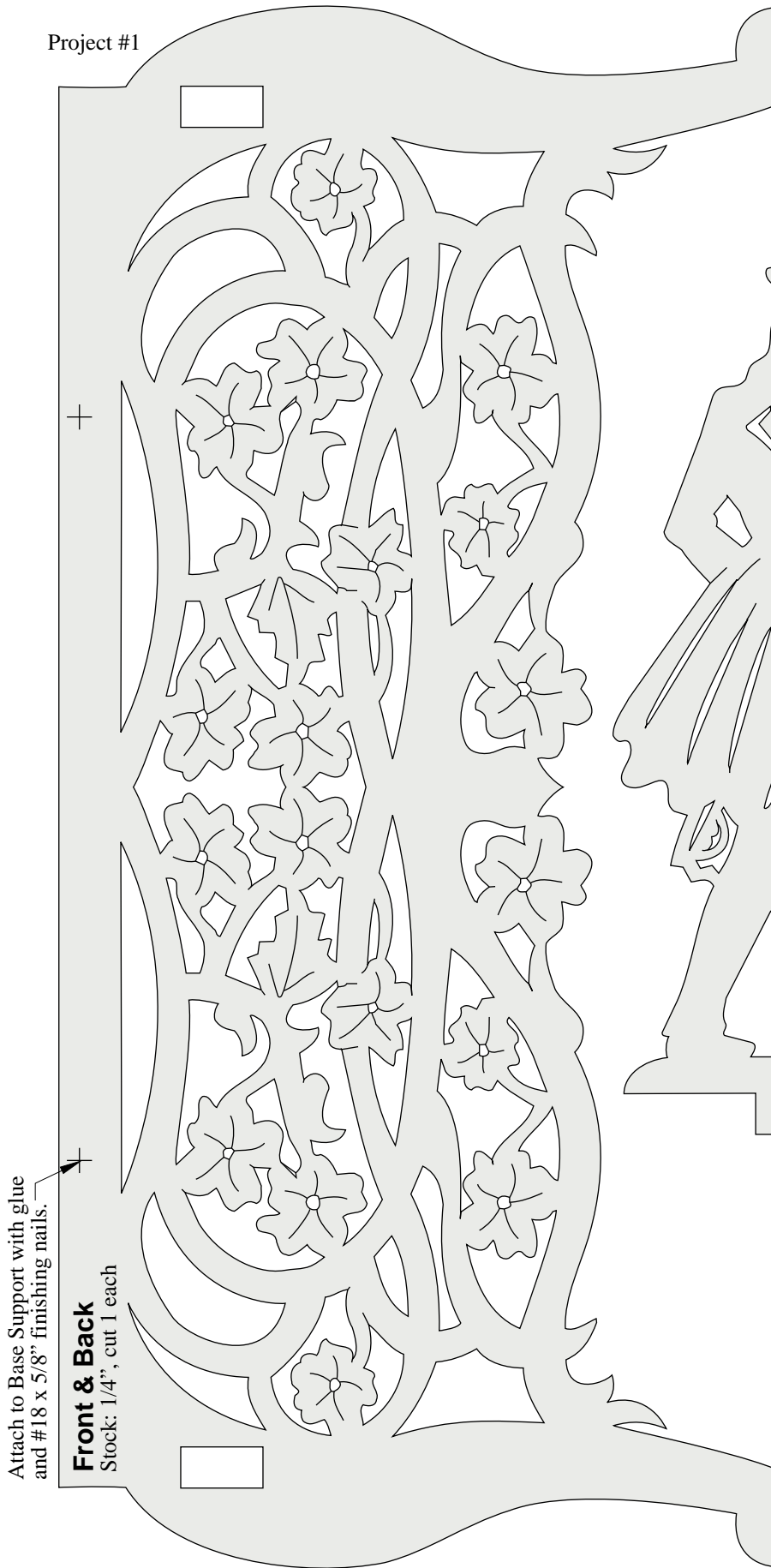

Attach to Base Support with glue and #18 x 5/8" finishing nails.

Front & Back
Stock: 1/4", cut 1 each



Figures
Stock: 1/4"

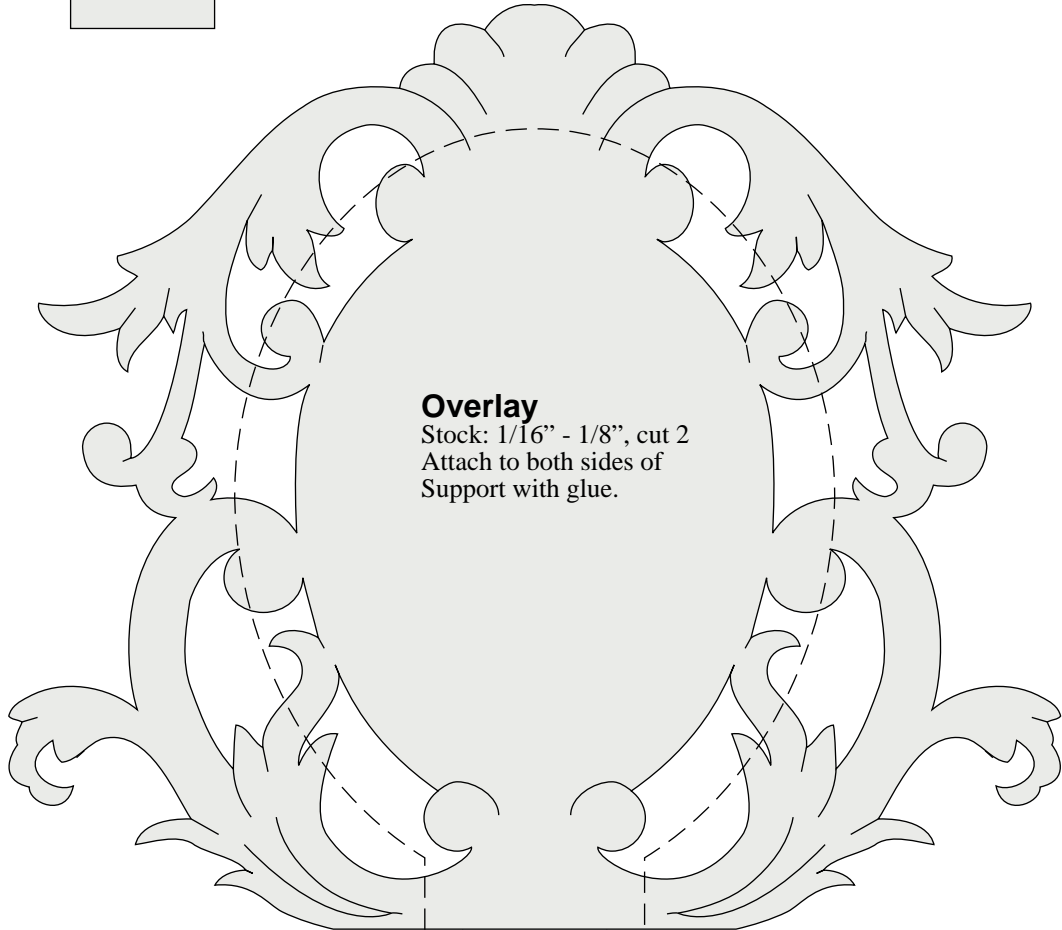
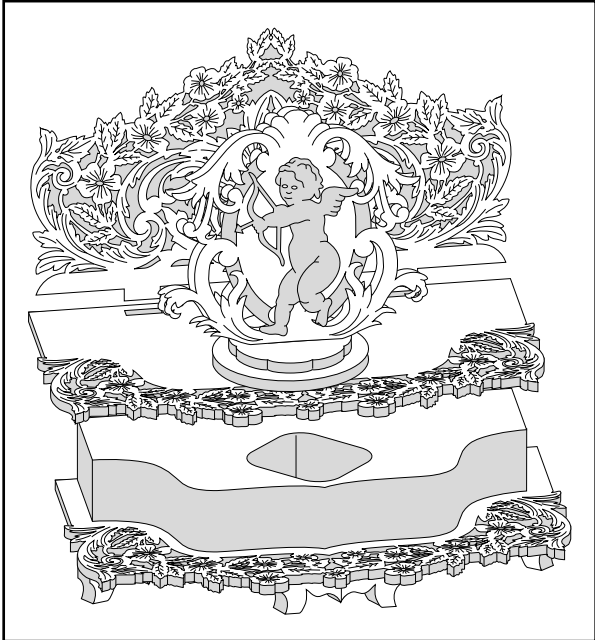
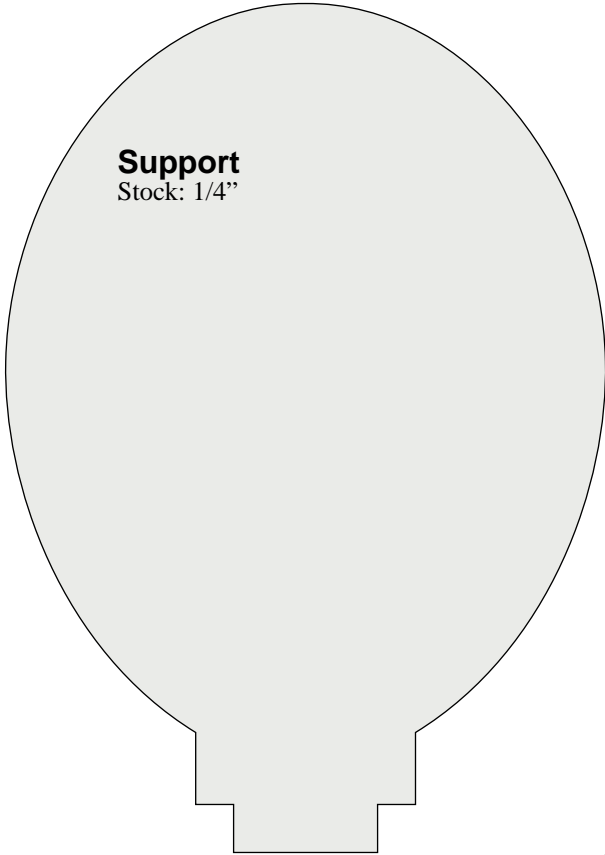

Dashed line indicates Placement of Support.

Project #2



Figure
Stock: 1/16" - 1/8", cut 2

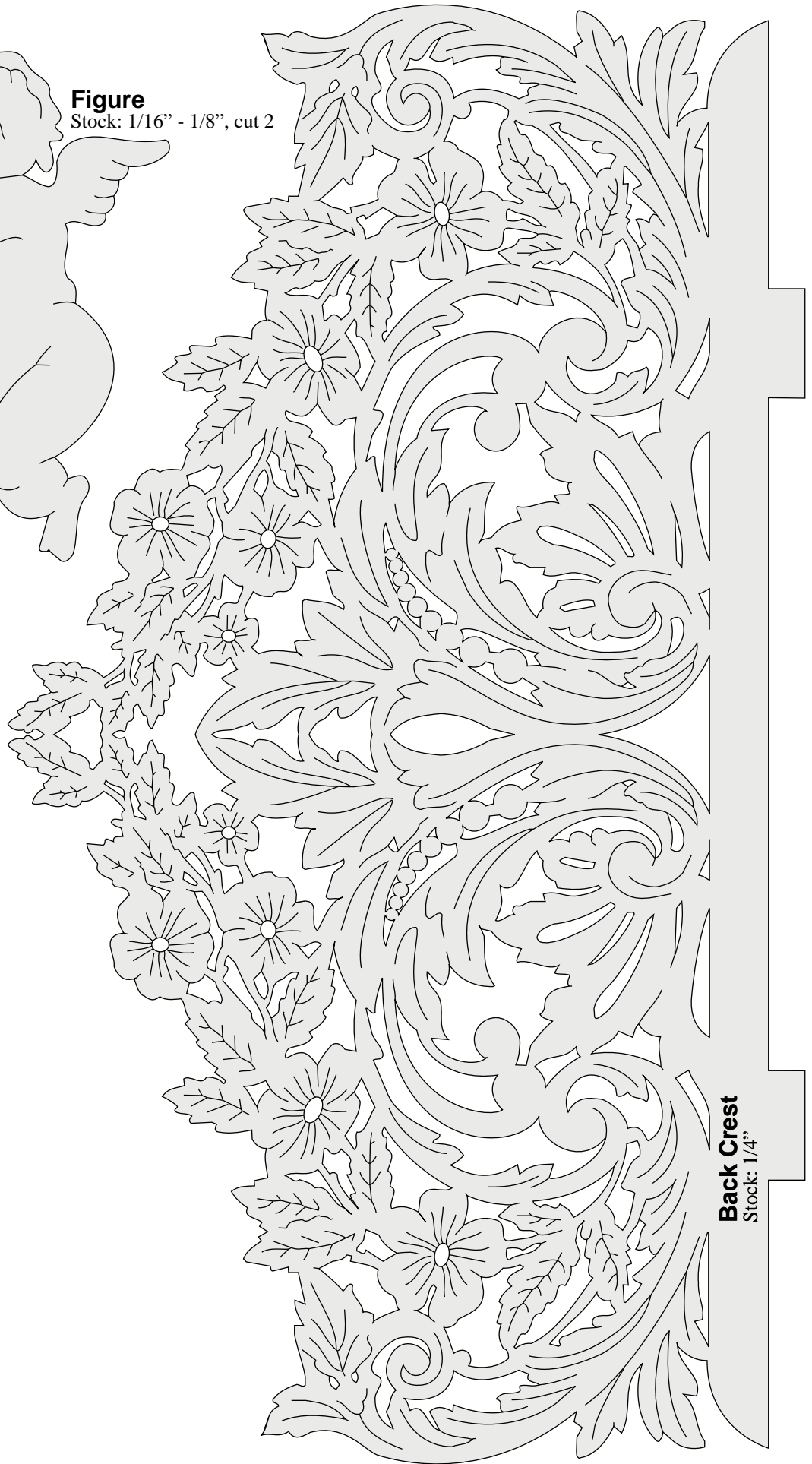

Back Crest
Stock: 1/4"

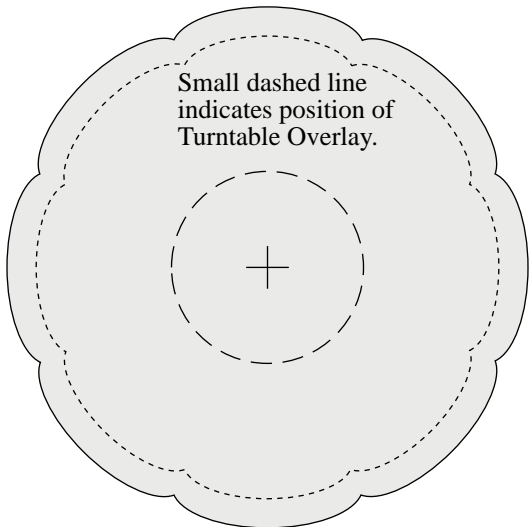
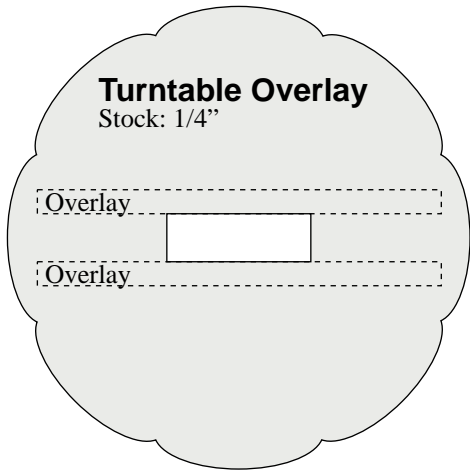
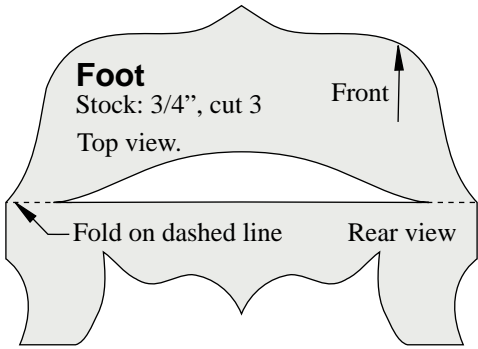

Turntable

Stock: 1/4", countersink the bottomside with a 1" forstner bit 1/16" deep. Secure the metal turntable with super glue or silicone.

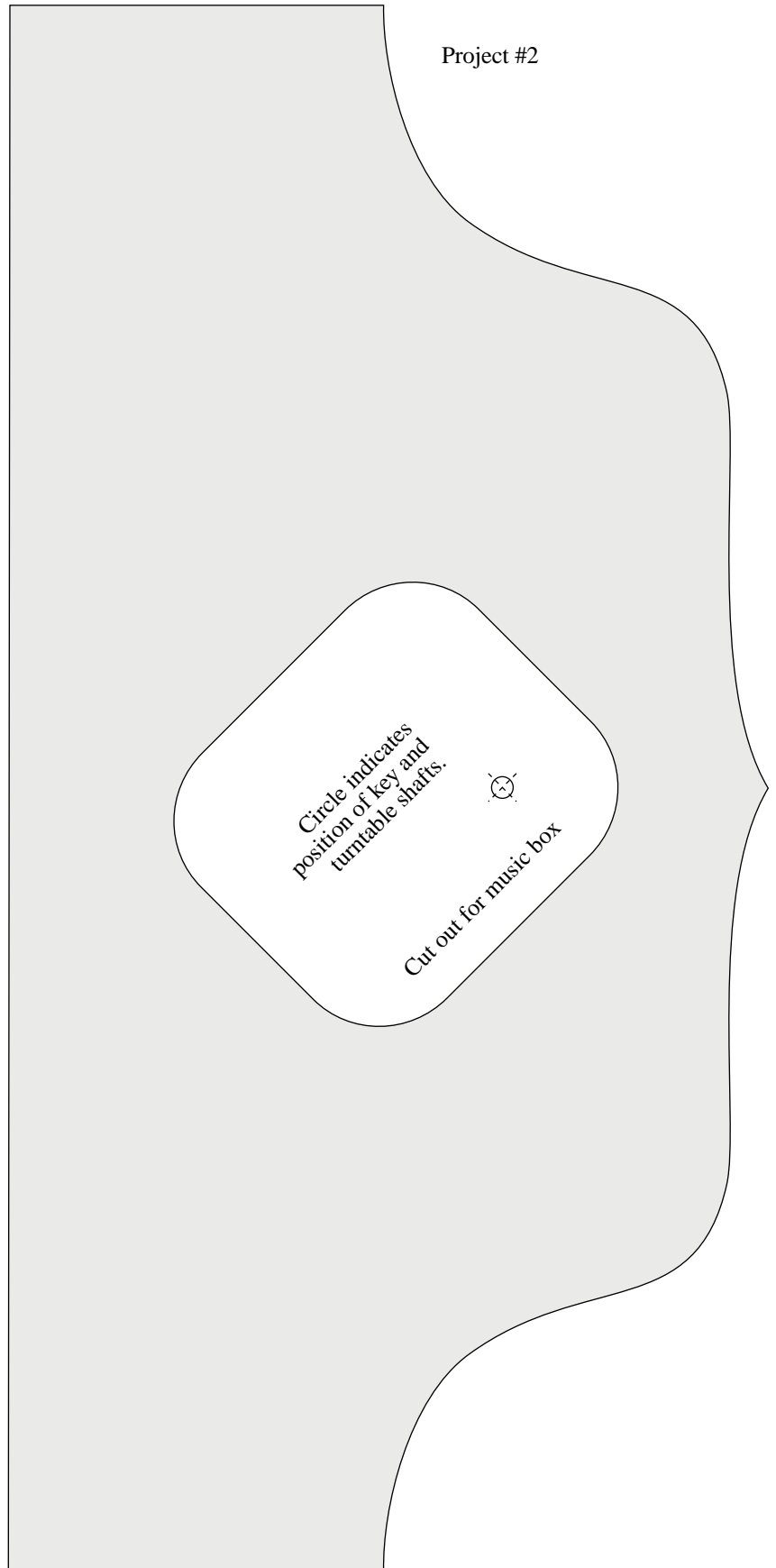

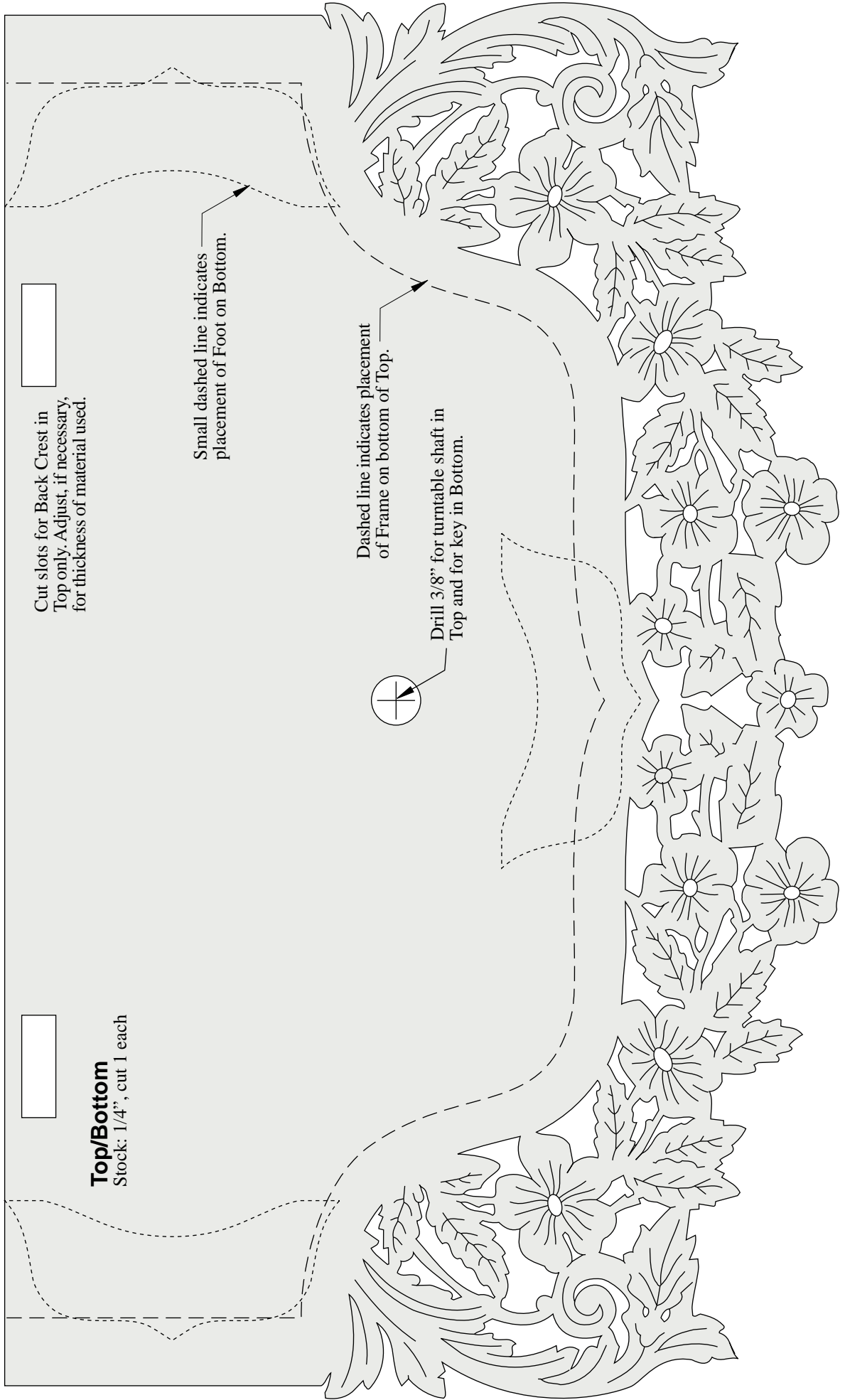

Project #3

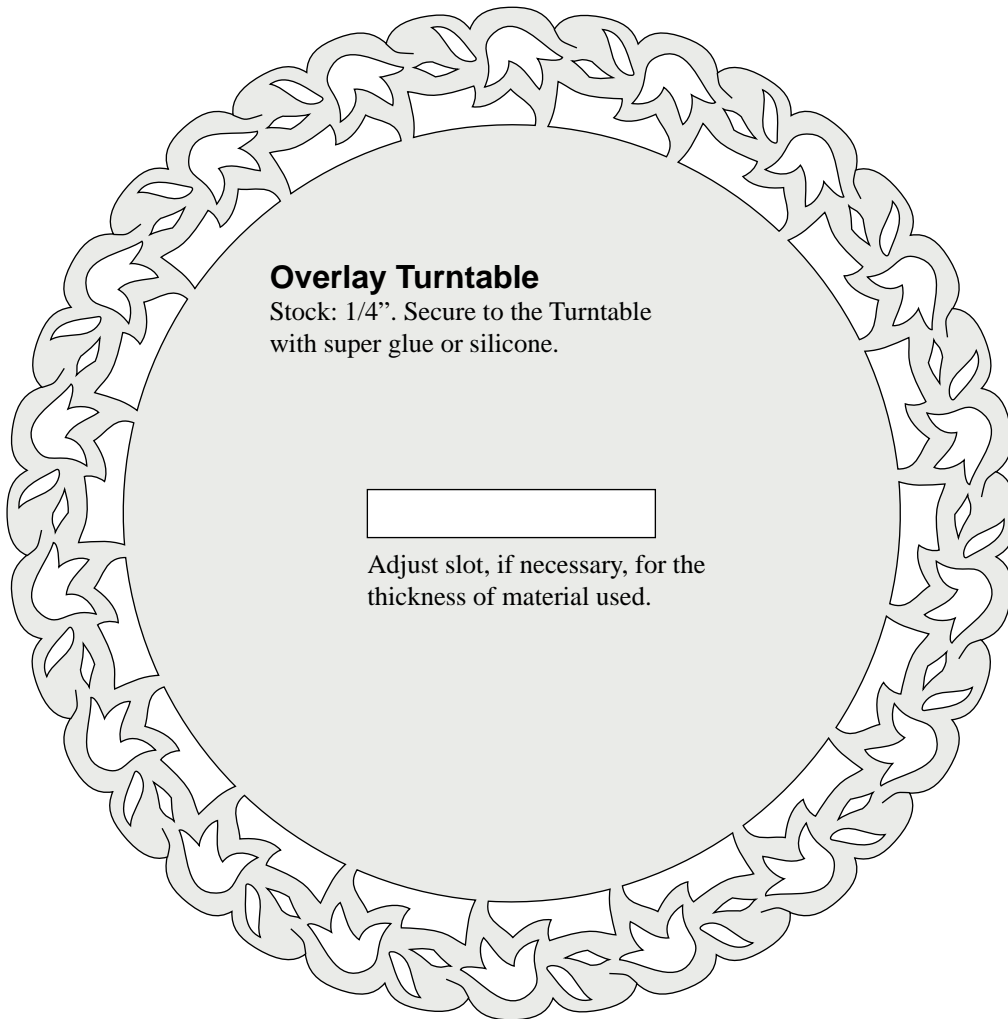
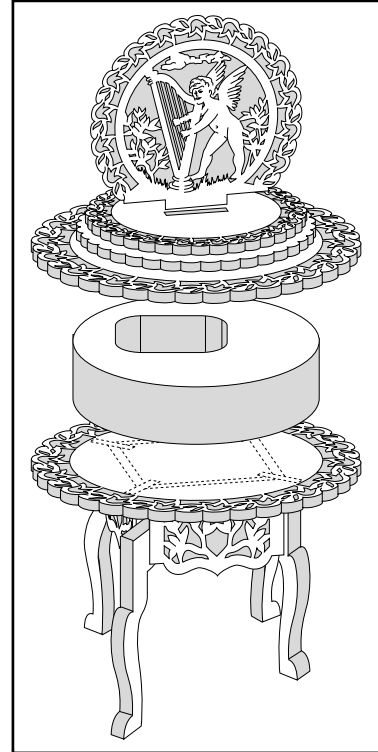

Project #3

Frame
Stock: 1 1/2"

Circle indicates
position of key and
turntable shafts.



Cut out for music box

Figure
Stock: 1/4"

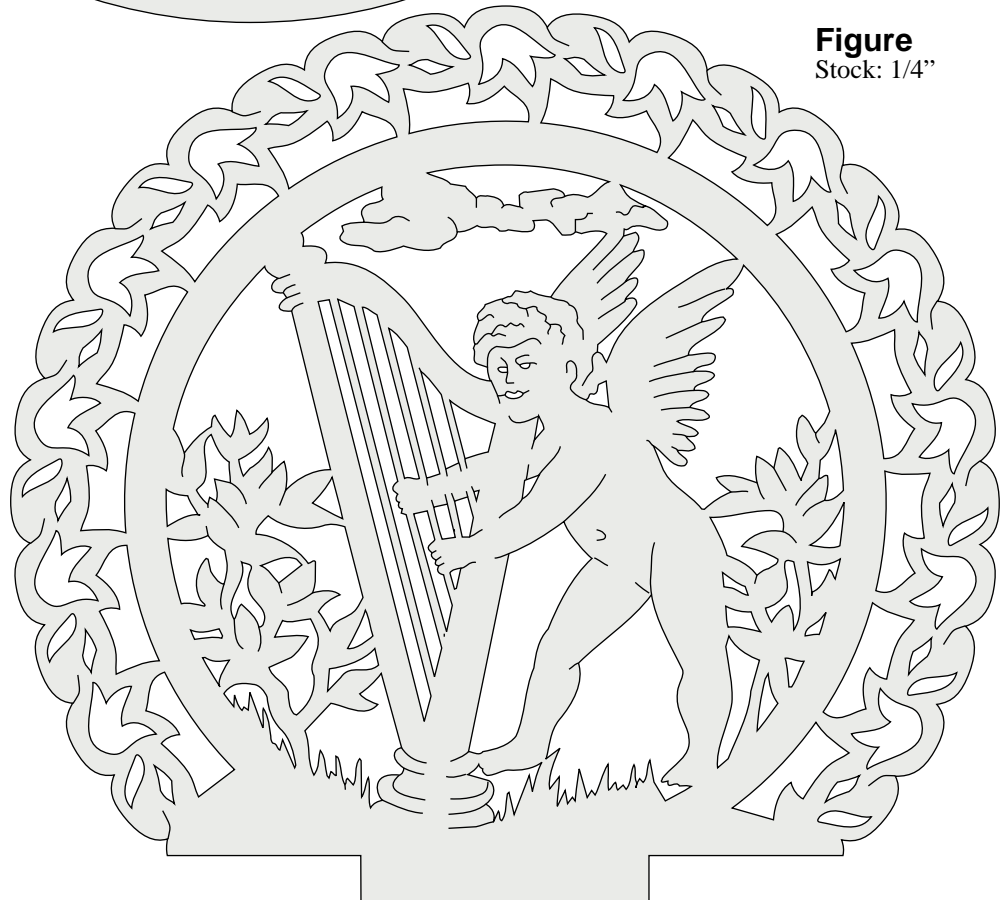

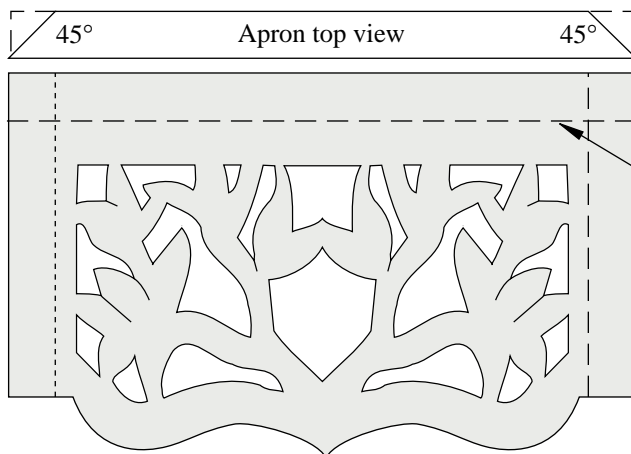
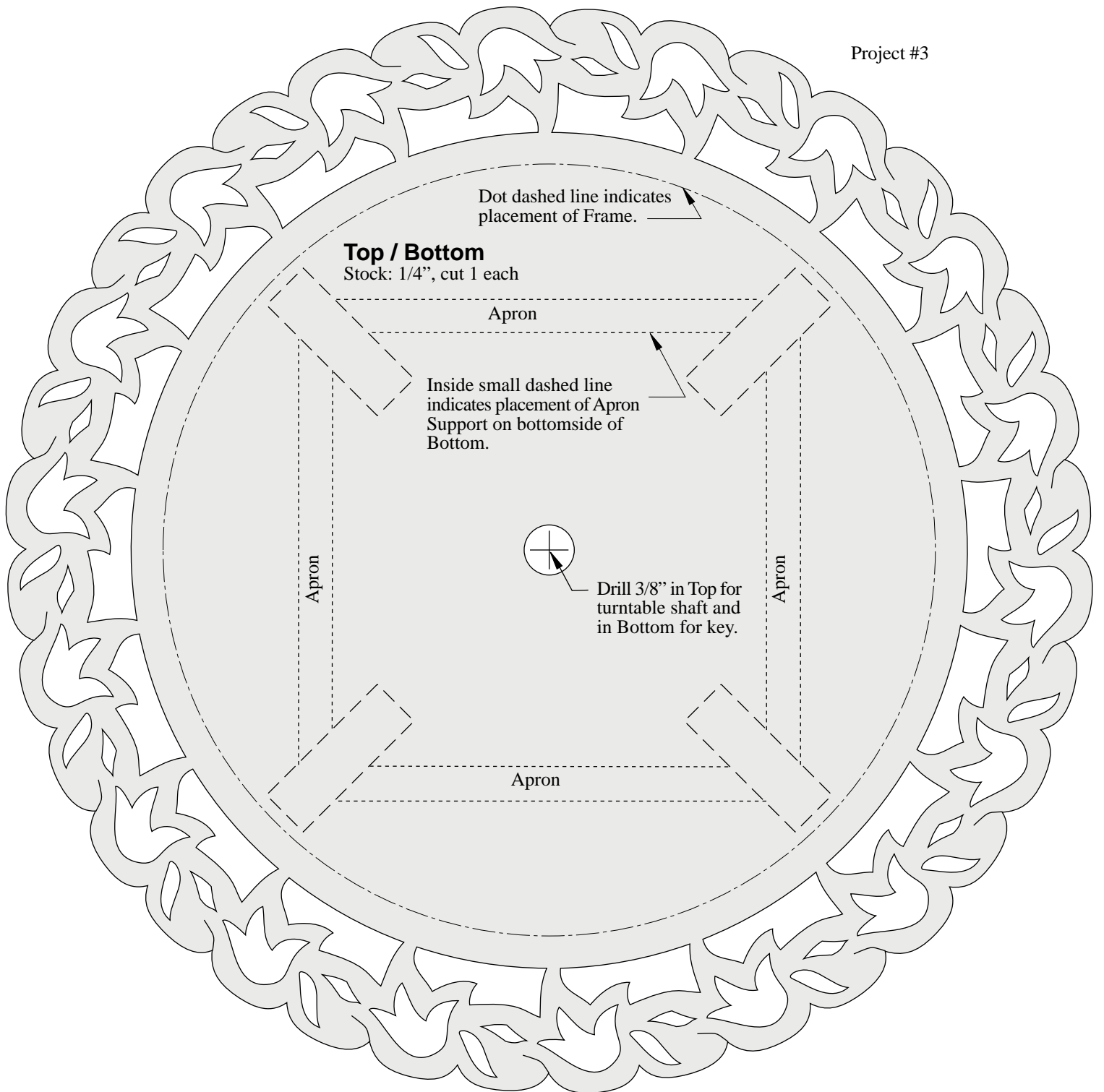

Apron
Stock: 1/4", cut 4

Dashed line indicates placement of Apron. Attach Apron to Apron Support with glue. Note: bevel cut sides at 45° before cutting pattern.

Project #3

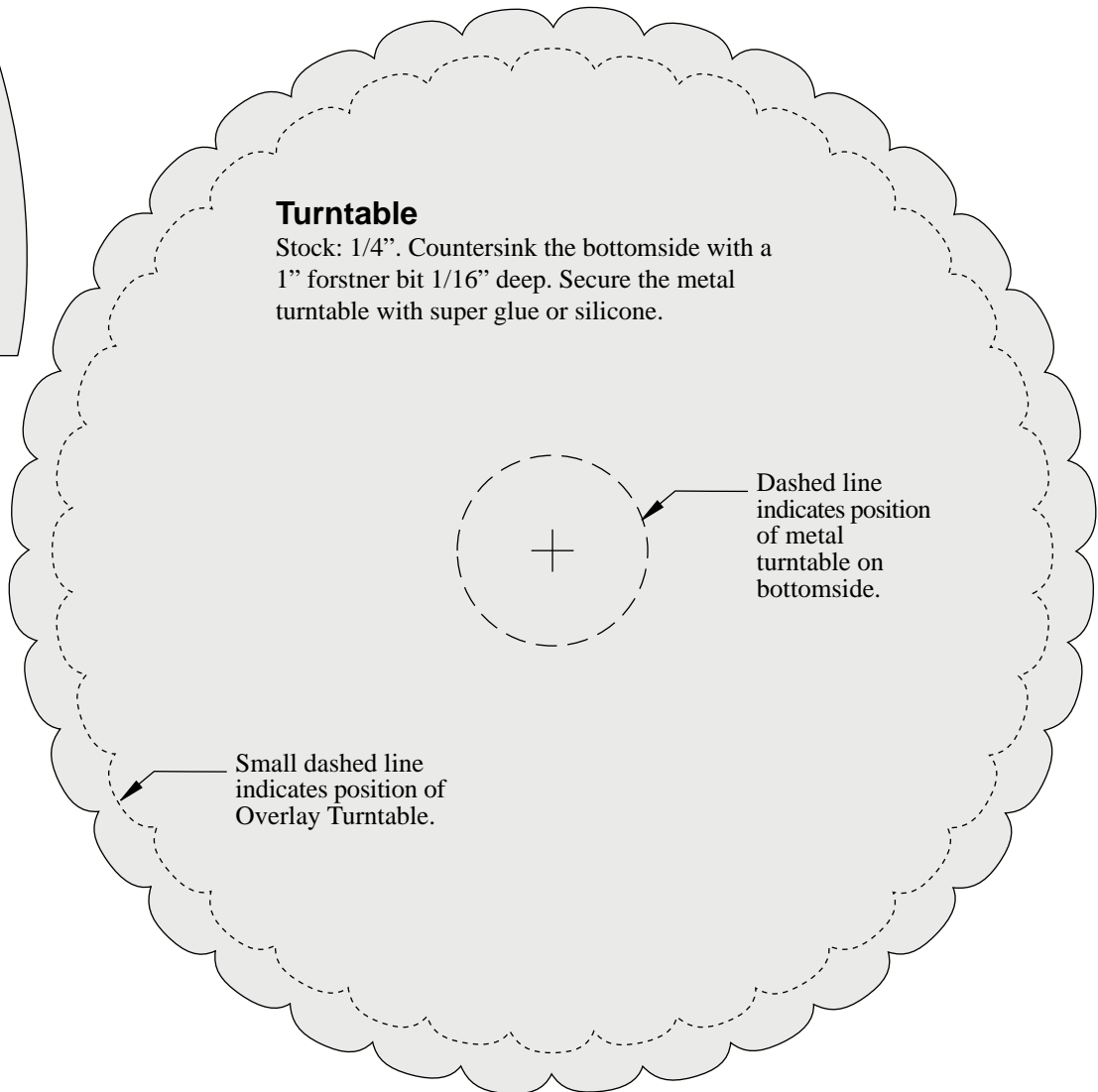
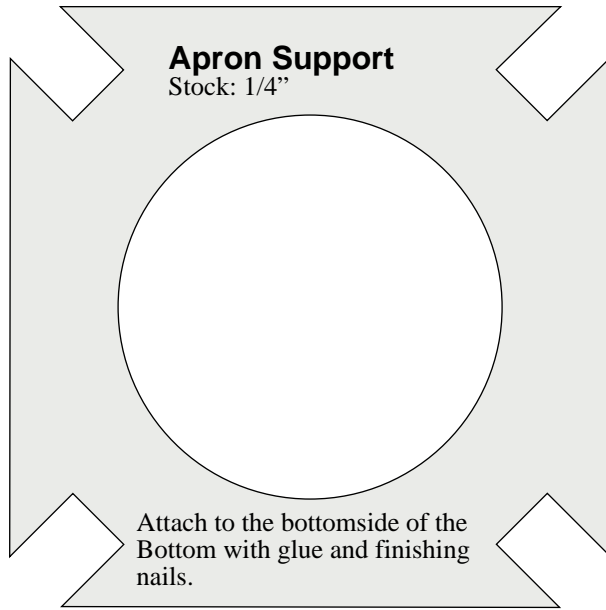
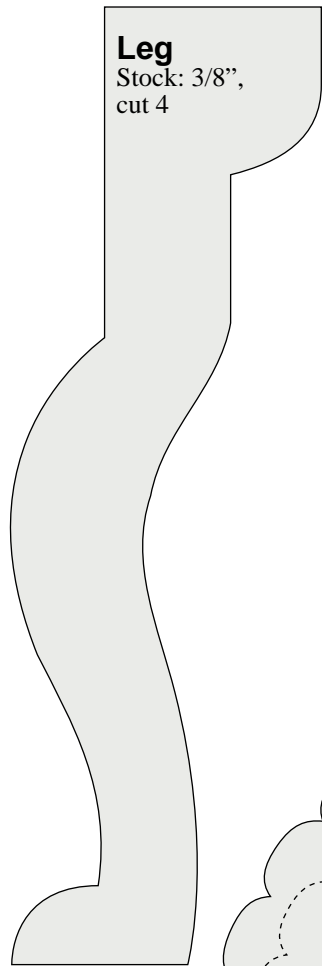

Project #4

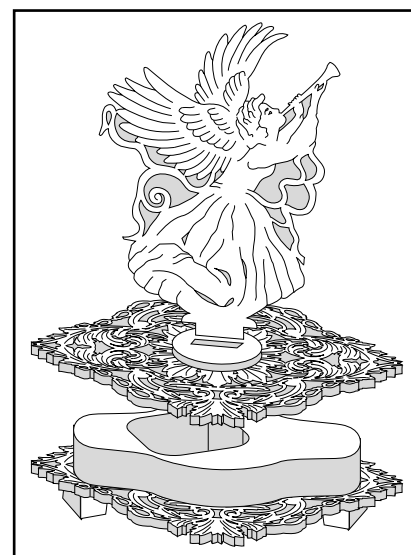

Angel
Stock: 1/4"

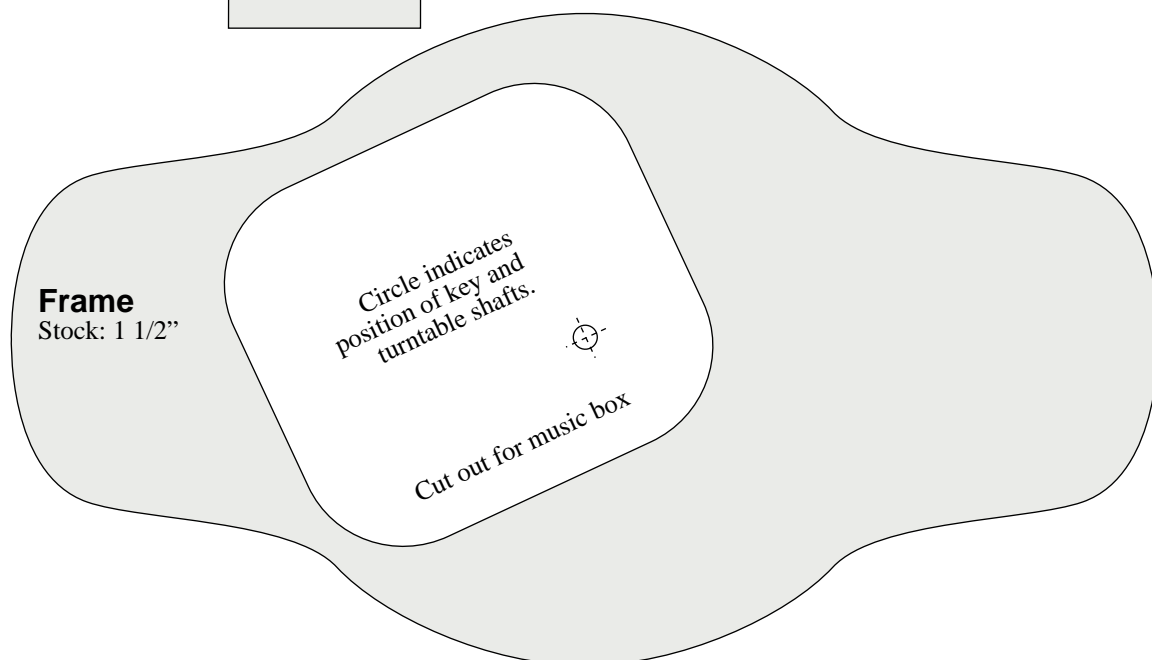

Project #4

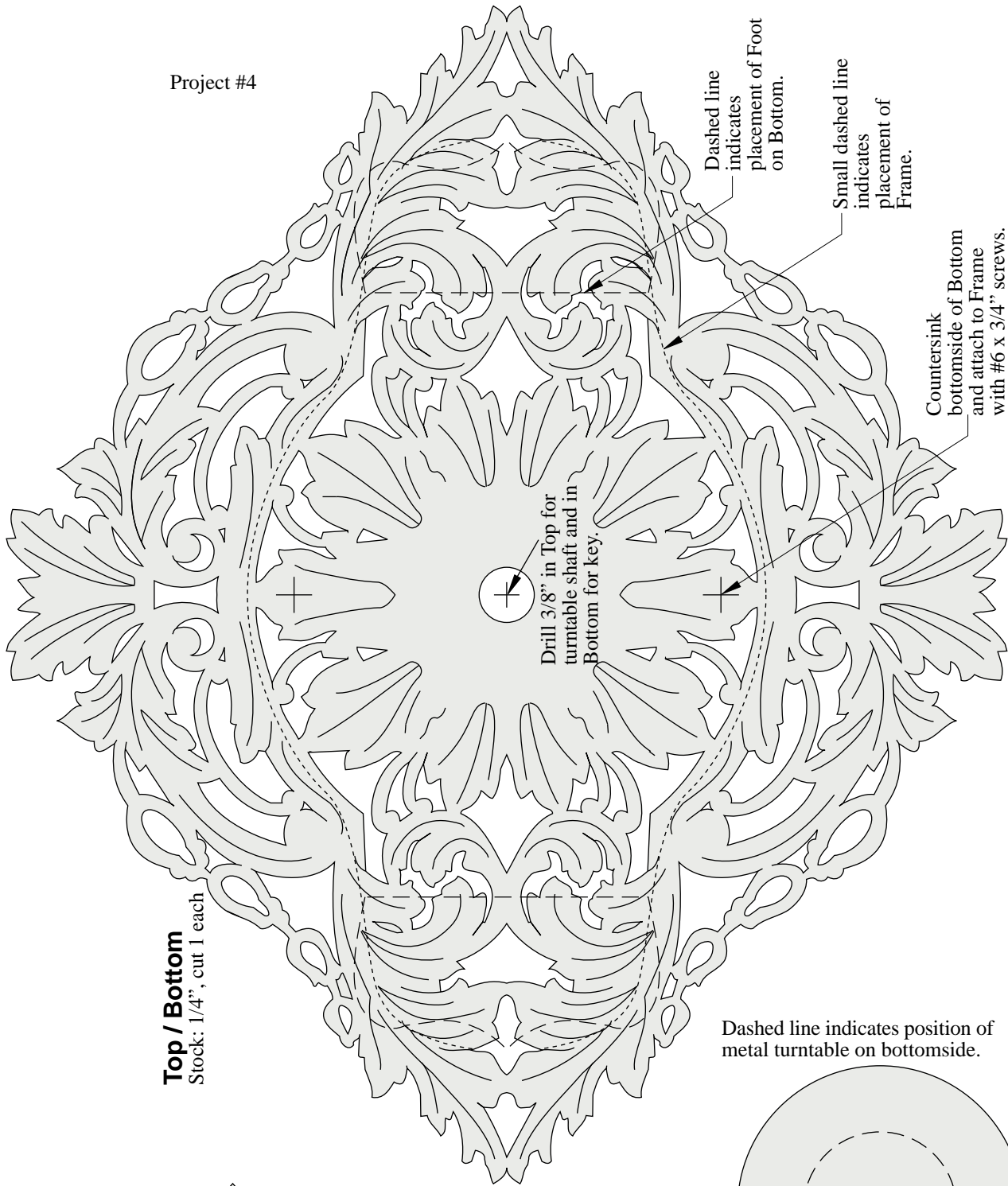

Dashed line indicates placement of Foot on Bottom.

Small dashed line indicates placement of Frame.

Countersink bottomsides of Bottom and attach to Frame with #6 x 3/4" screws.

Drill 3/8" in Top for turntable shaft and in Bottom for key.

Top / Bottom
Stock: 1/4", cut 1 each

Dashed line indicates position of metal turntable on bottomsides.

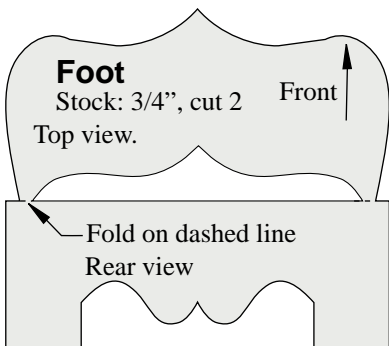
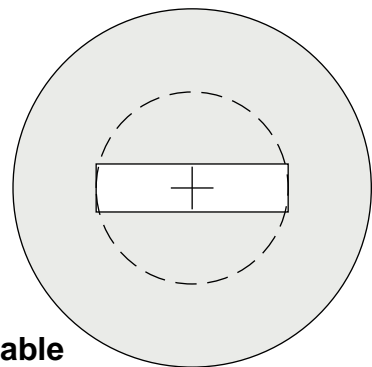

Foot
Stock: 3/4", cut 2
Top view.

Fold on dashed line
Rear view

Turntable

Stock: 3/8", countersink the bottomsides with a 1" forstner bit 1/16" deep. Secure the metal turntable with super glue or silicone. Note: countersink bottomsides before cutting slot.

Turntable

Stock: 1/4", countersink the
bottomside with a 1" forstner bit
1/16" deep. Secure the metal
turntable with super glue or silicone.



Adjust slots, if
necessary, for thickness
of material used.

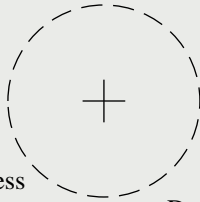

Dashed line
indicates position
of metal turntable
on bottomside.

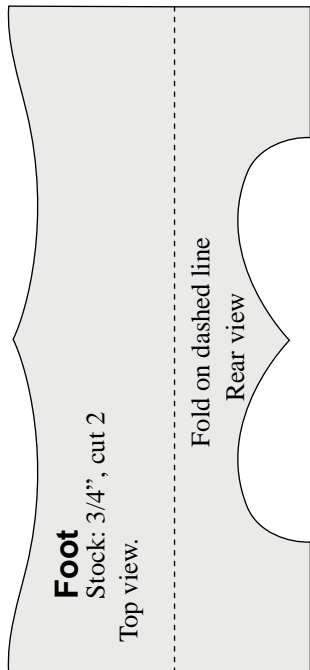
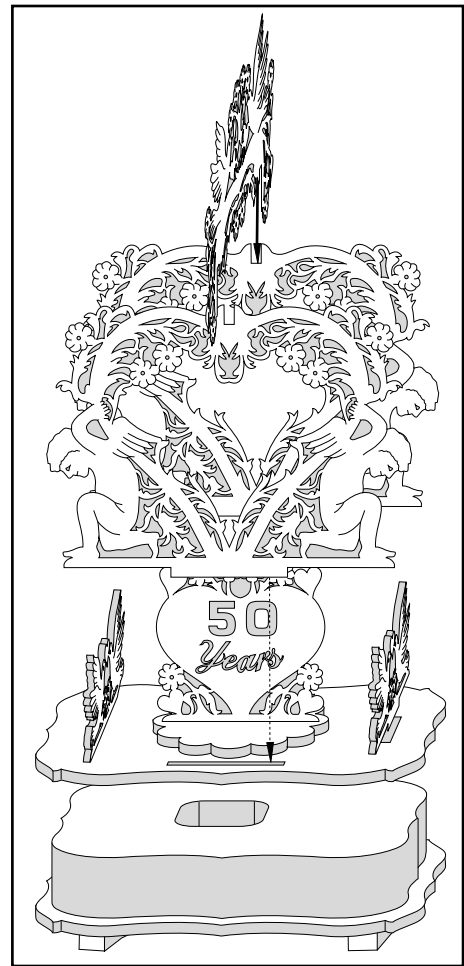

Foot
Stock: 3/4", cut 2
Top view.

Fold on dashed line
Rear view

Figure
Stock: 1/4"

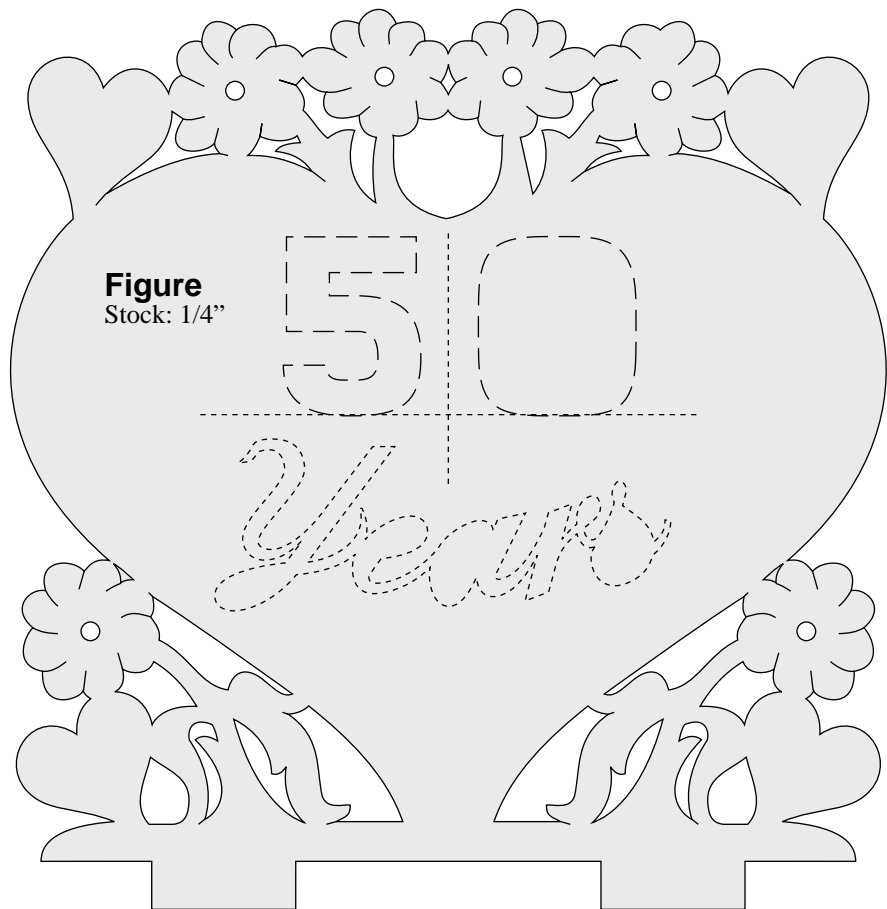

Text Overlay
Stock: 1/16" - 1/8"
Years

Project #5

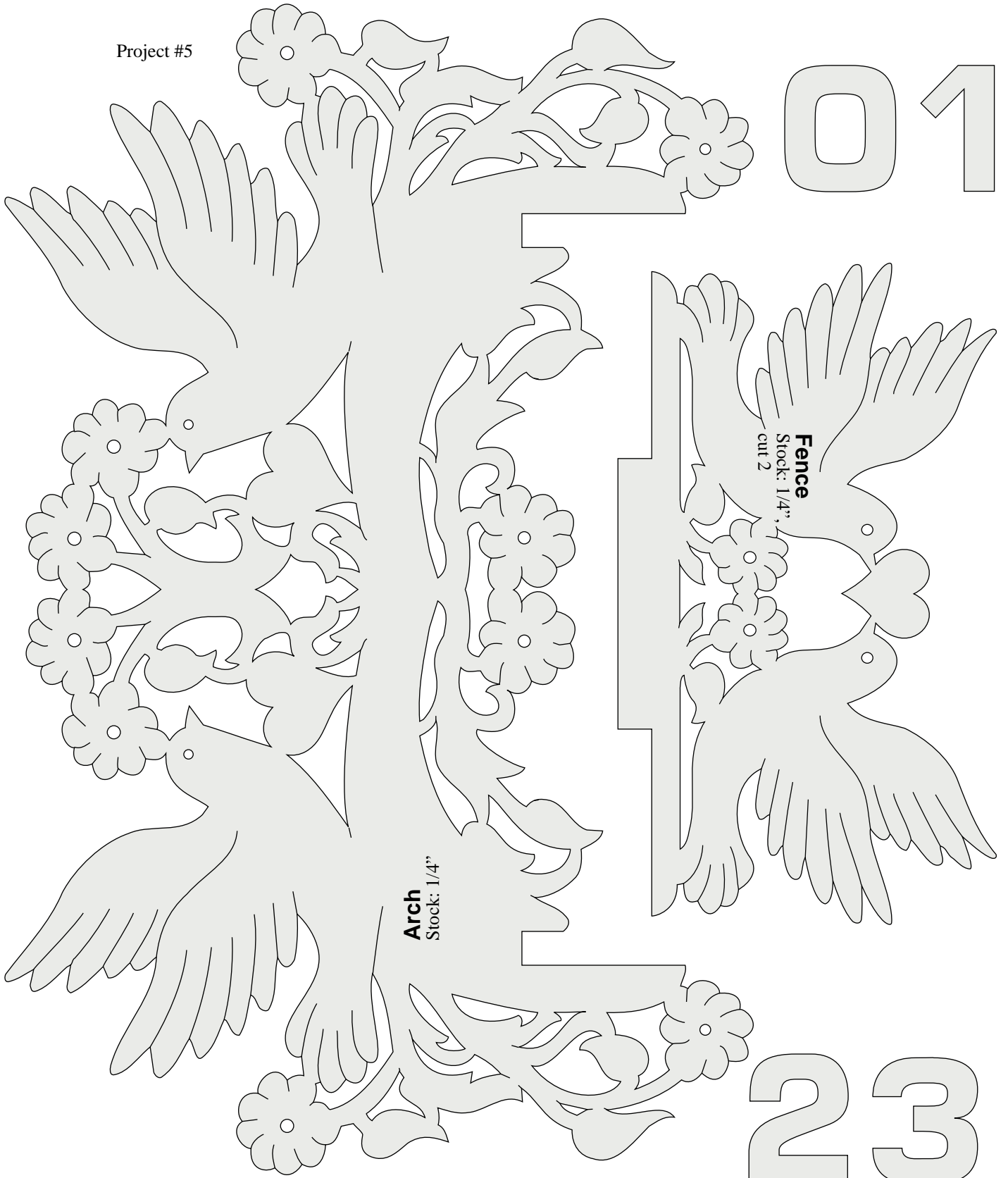

Arch
Stock: 1/4"

Fence
Stock: 1/4",
cut 2

0 1

2 3

Number Overlays
Stock: 1/16" - 1/8"

4 5 6 7 8 9



Arch Support
Stock: 1/4", cut 2

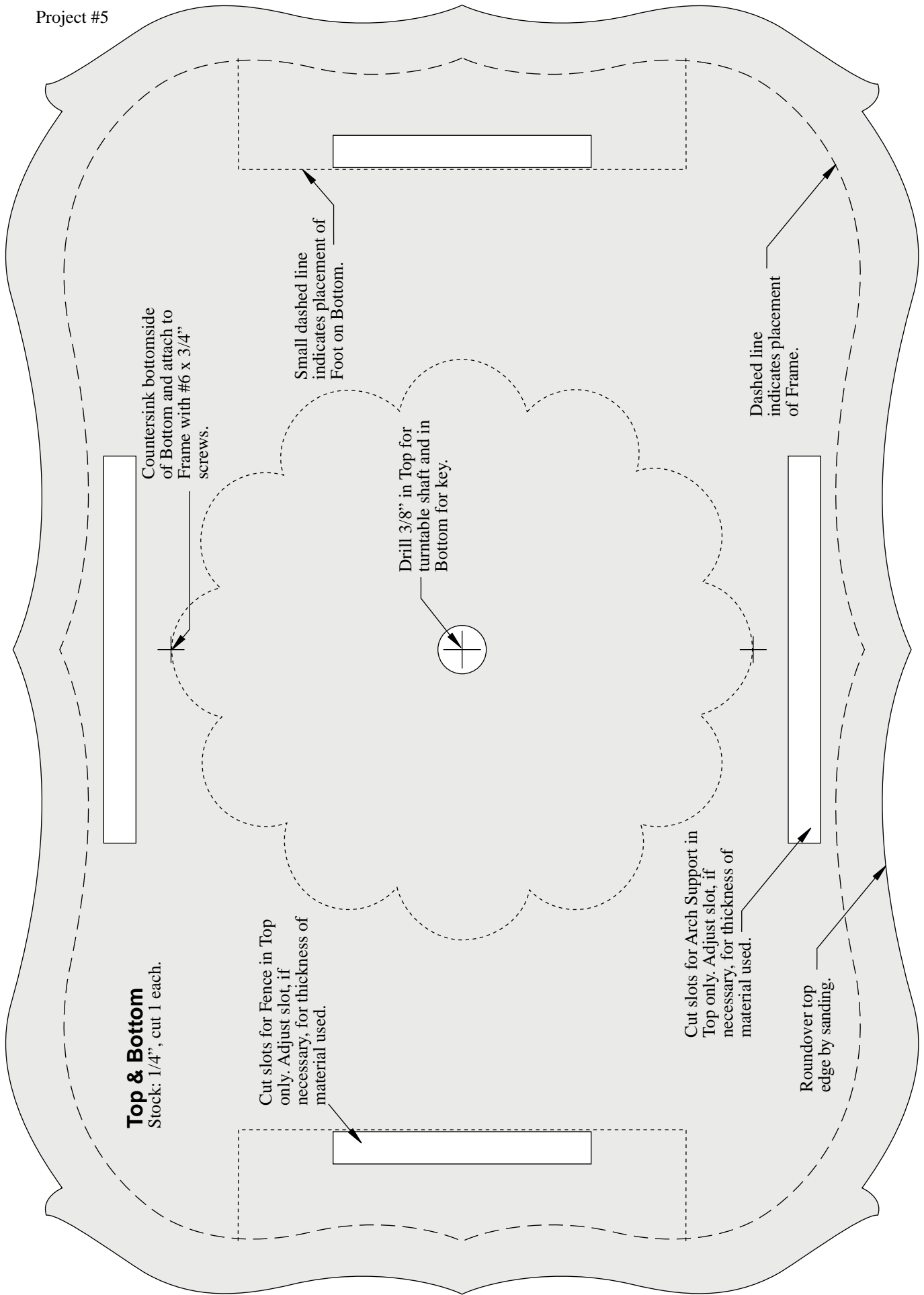

Top & Bottom

Stock: 1/4", cut 1 each.

Countersink bottomsides of Bottom and attach to Frame with #6 x 3/4" screws.

Cut slots for Fence in Top only. Adjust slot, if necessary, for thickness of material used.

Drill 3/8" in Top for turntable shaft and in Bottom for key.

Small dashed line indicates placement of Foot on Bottom.

Dashed line indicates placement of Frame.

Cut slots for Arch Support in Top only. Adjust slot, if necessary, for thickness of material used.

Roundover top edge by sanding.

Frame
Stock: 1 1/2"

Circle indicates
position of key and
turntable shafts.



Cut out for music box

Project #6

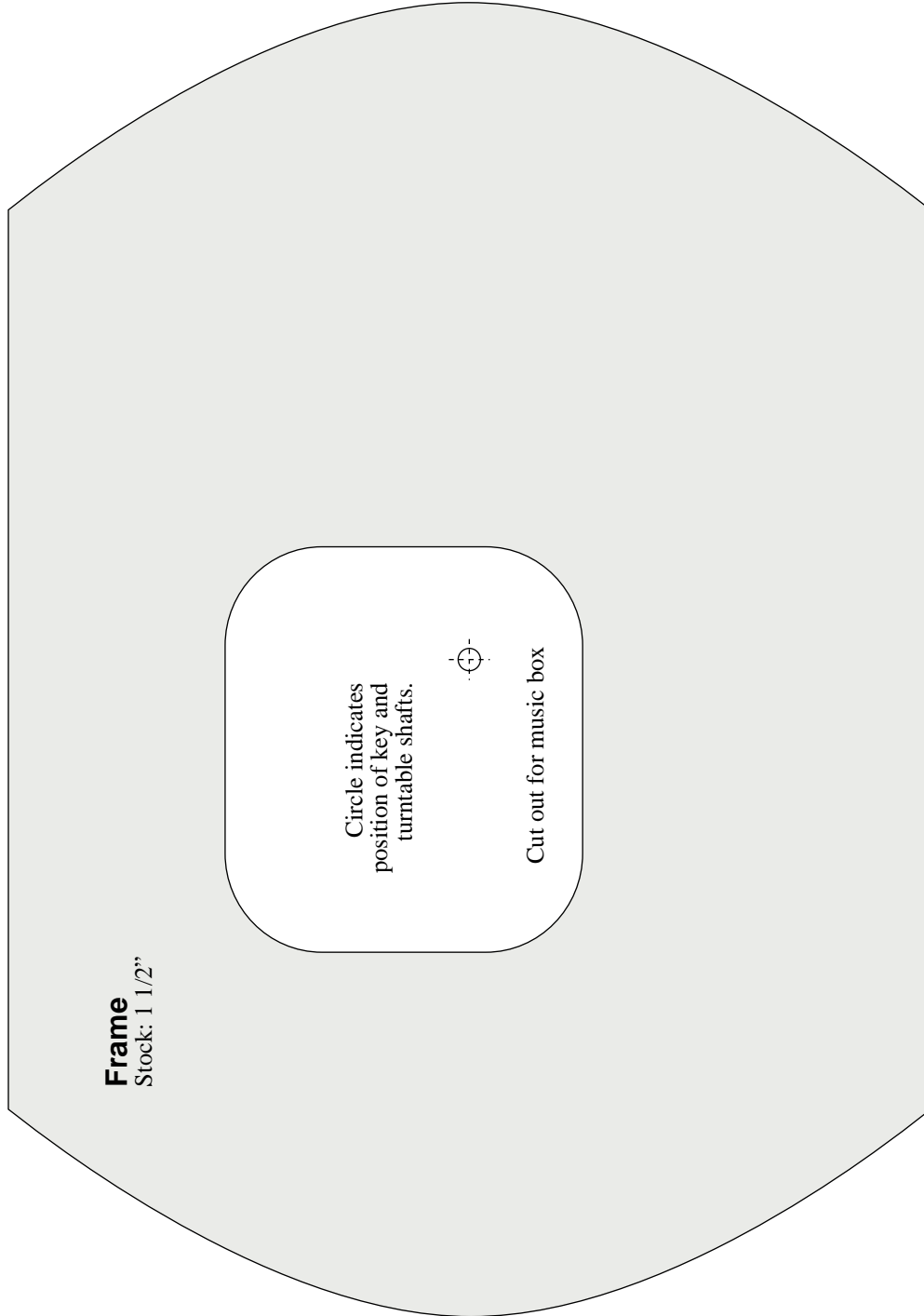
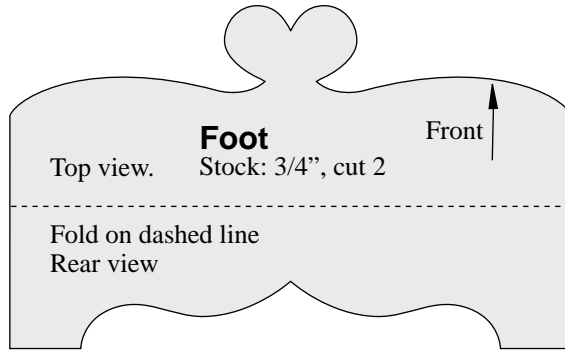

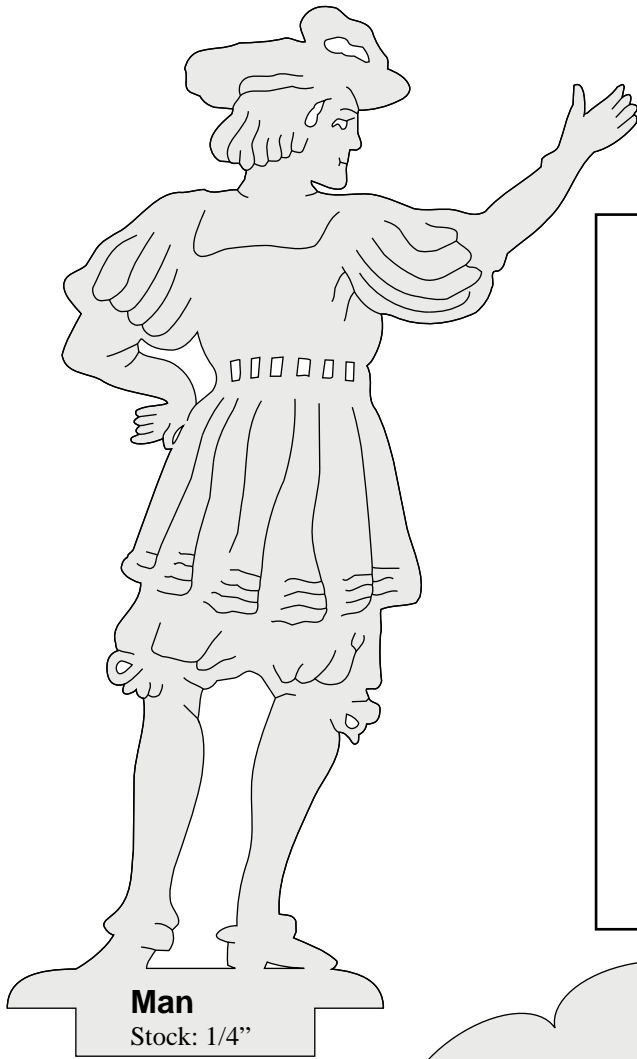

Man
Stock: 1/4"



Turntable

Stock: 1/4", countersink the bottomside with a 1" forstner bit 1/16" deep. Secure the metal turntable with super glue or silicone.

Adjust slots, if necessary, for the thickness of material used.

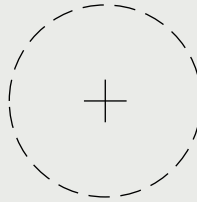

Dashed line indicates position of metal turntable on bottomside.

Project #6

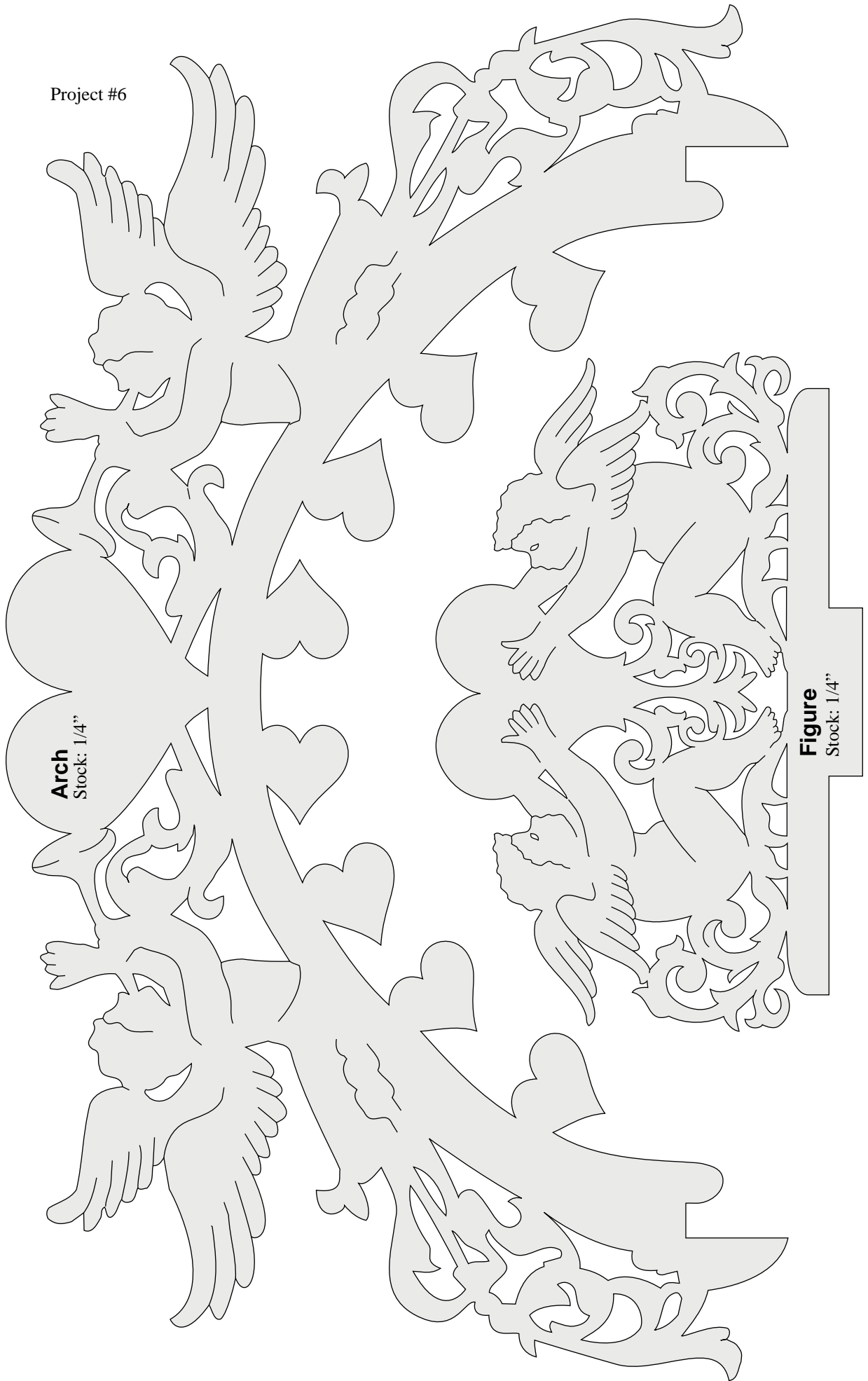

Arch
Stock: 1/4"

Figure
Stock: 1/4"

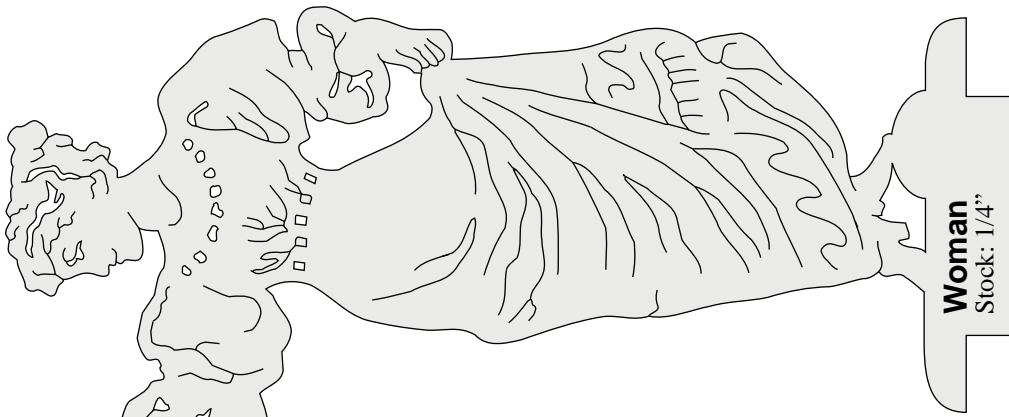

Woman
Stock: 1/4"

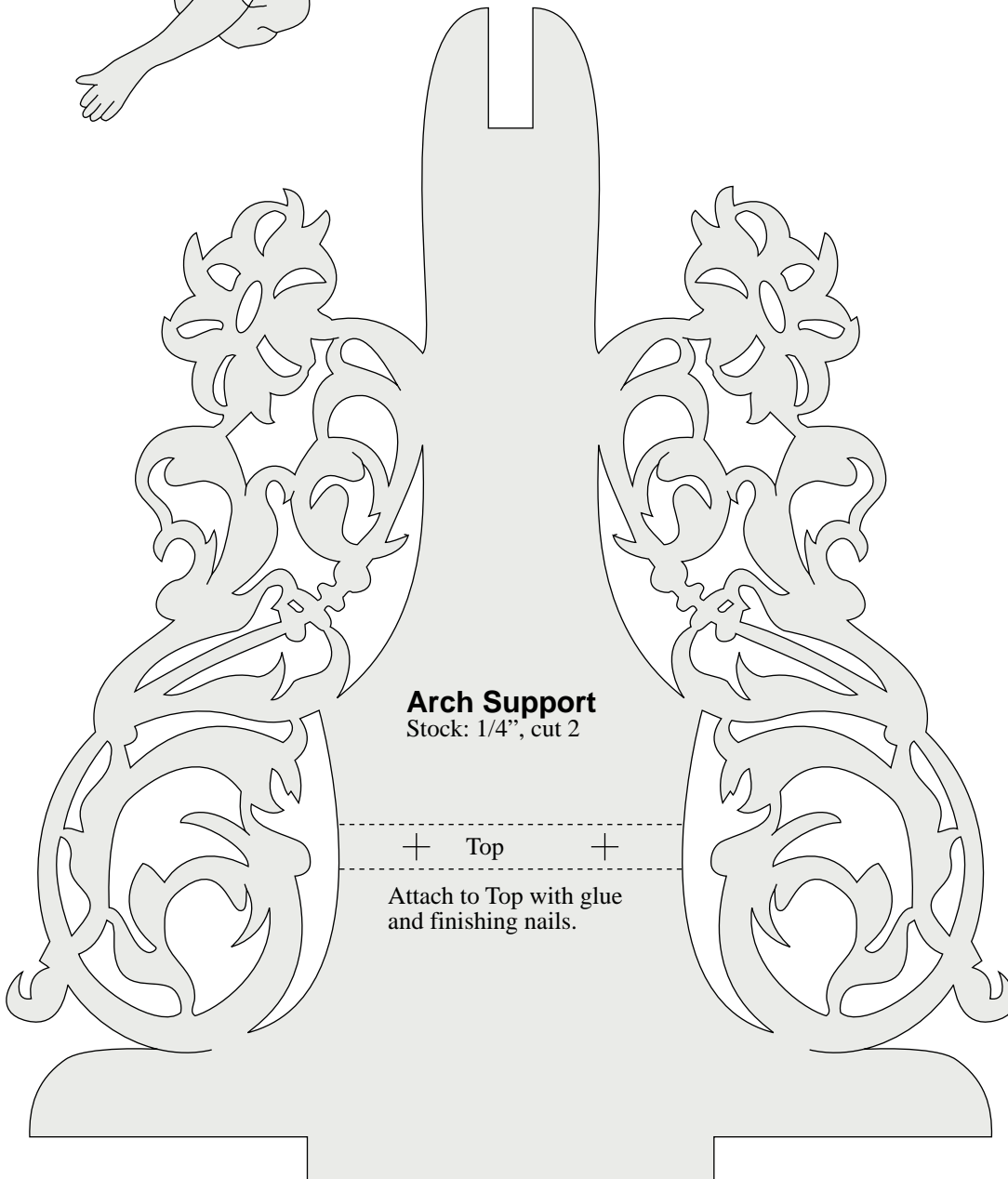

Arch Support
Stock: 1/4", cut 2

+ Top +

Attach to Top with glue
and finishing nails.

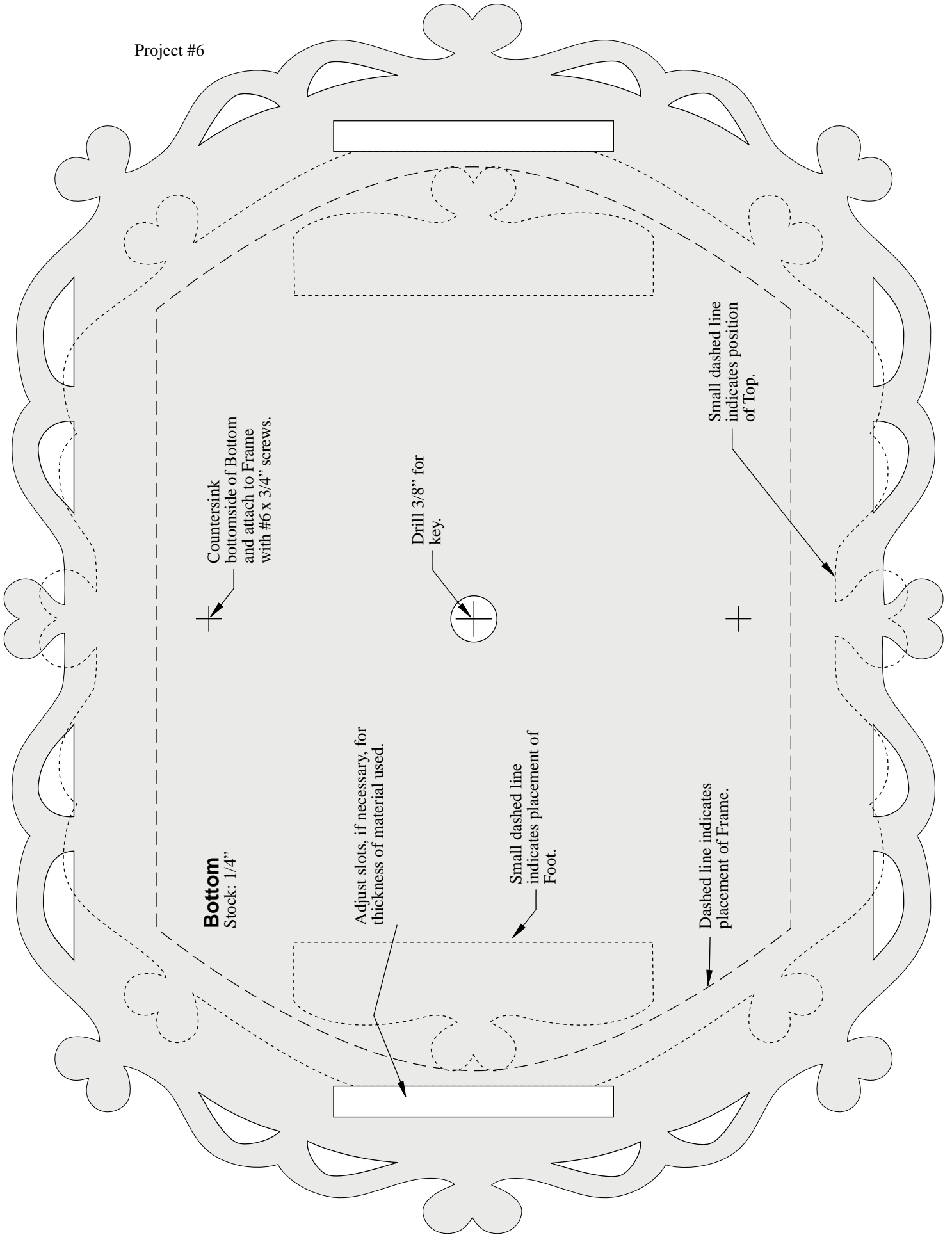

Bottom
Stock: 1/4"

Countersink
bottomsides of Bottom
and attach to Frame
with #6 x 3/4" screws.

Drill 3/8" for
key.

Adjust slots, if necessary, for
thickness of material used.

Small dashed line
indicates placement of
Foot.

Dashed line indicates
placement of Frame.

Small dashed line
indicates position
of Top.

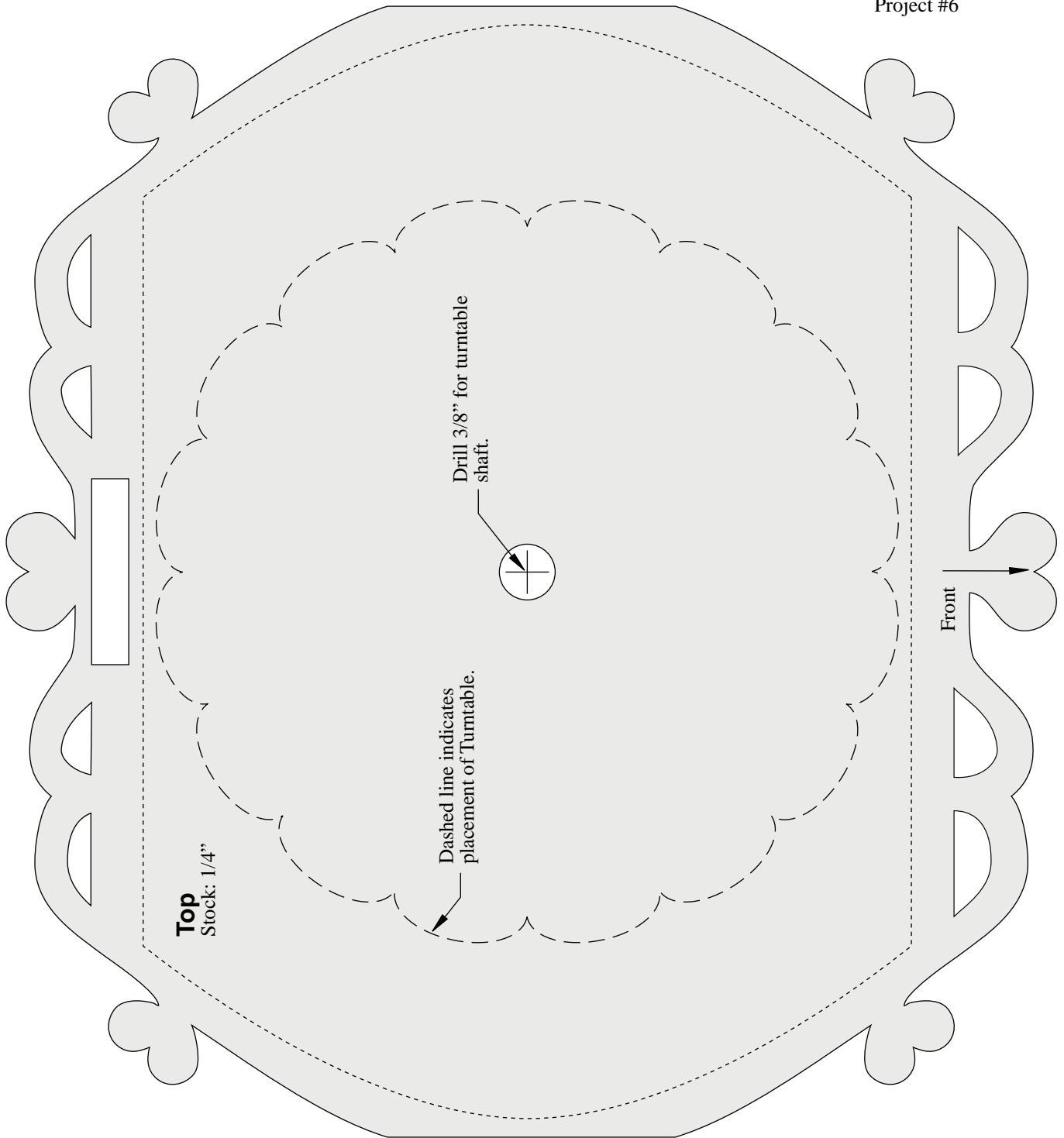

Top
Stock: 1/4"

Dashed line indicates
placement of Turntable.

Drill 3/8" for turntable
shaft.

Front

Project #7

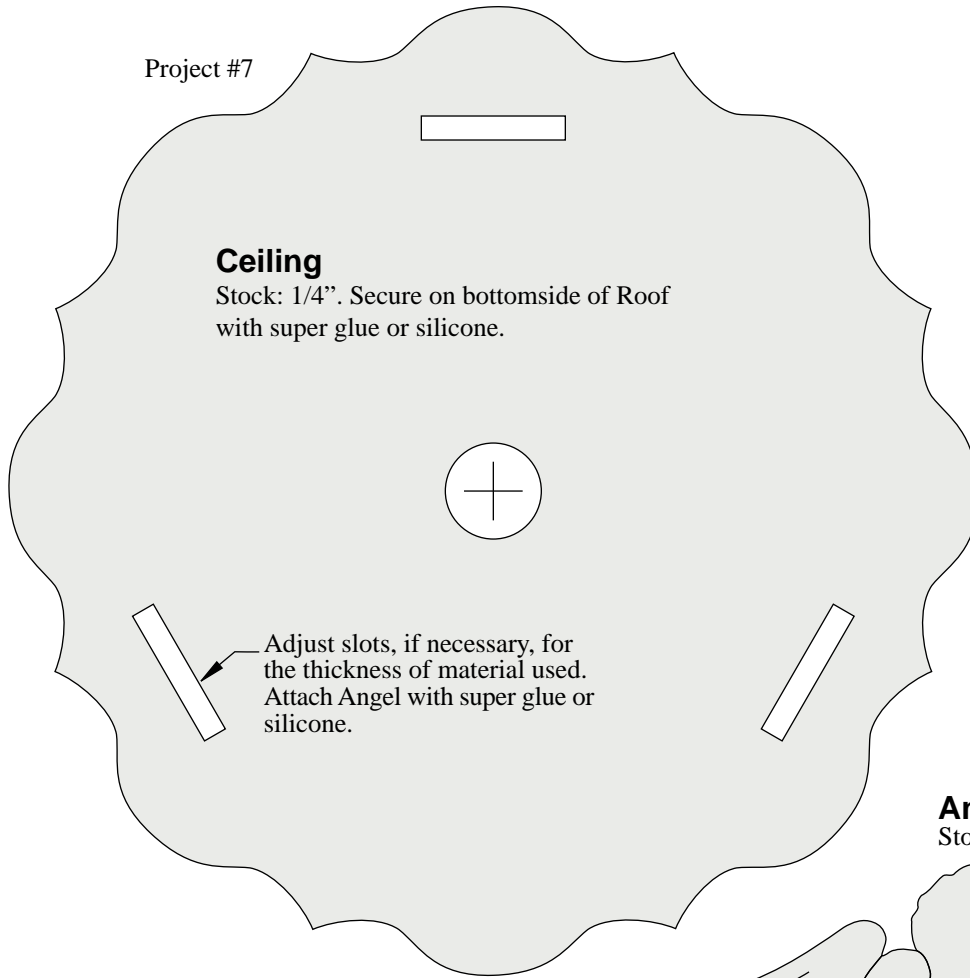

Ceiling

Stock: 1/4". Secure on bottomside of Roof with super glue or silicone.

Adjust slots, if necessary, for the thickness of material used. Attach Angel with super glue or silicone.

Angel

Stock: 1/8", cut 3

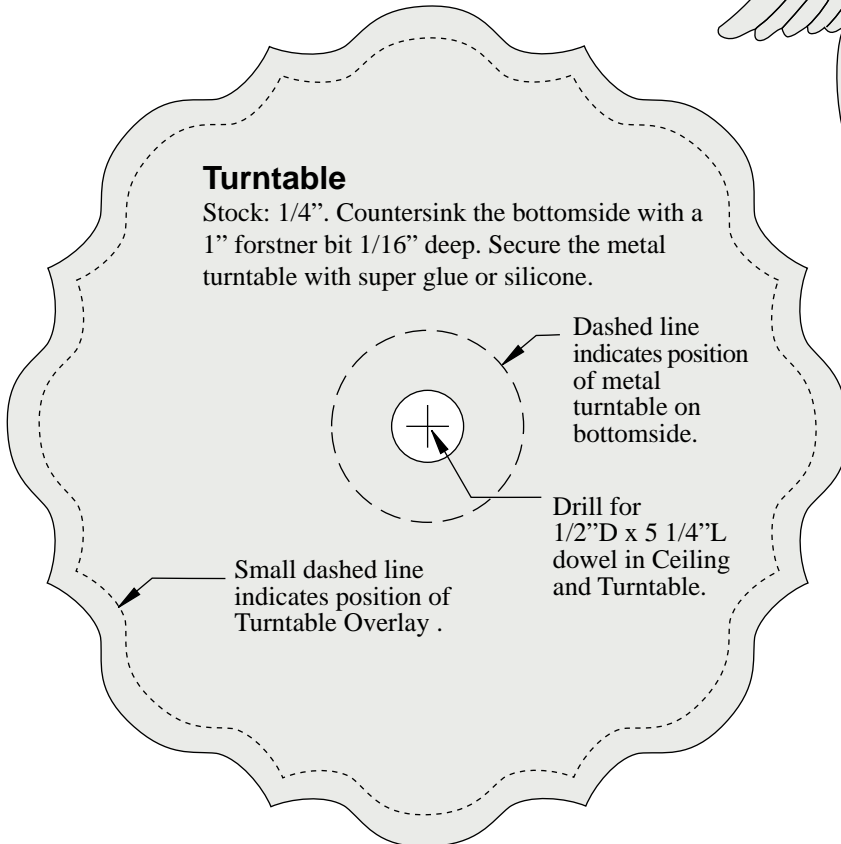
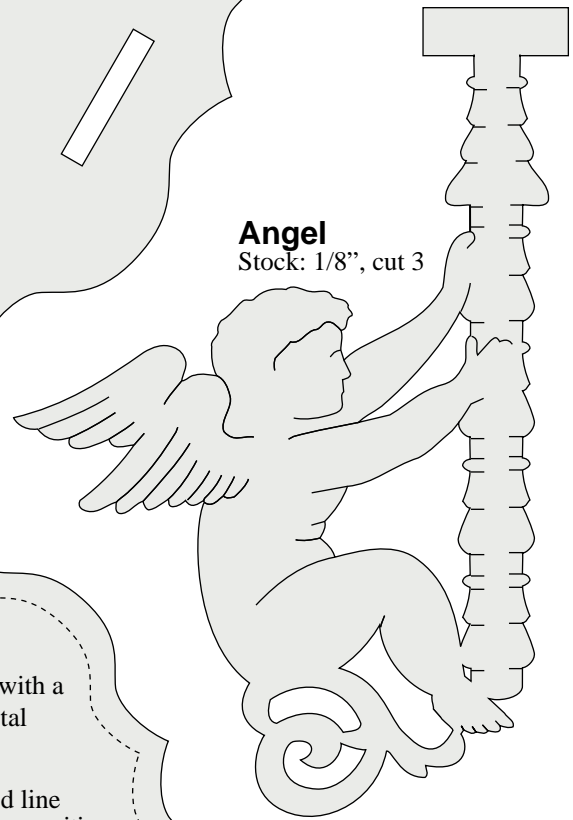

Turntable

Stock: 1/4". Countersink the bottomside with a 1" forstner bit 1/16" deep. Secure the metal turntable with super glue or silicone.

Dashed line indicates position of metal turntable on bottomside.

Drill for 1/2"D x 5 1/4"L dowel in Ceiling and Turntable.

Small dashed line indicates position of Turntable Overlay .

Top section

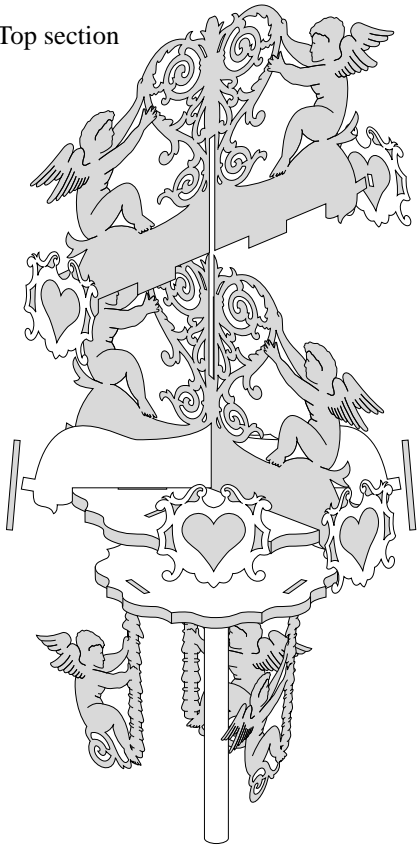

Project #7

Bottom section

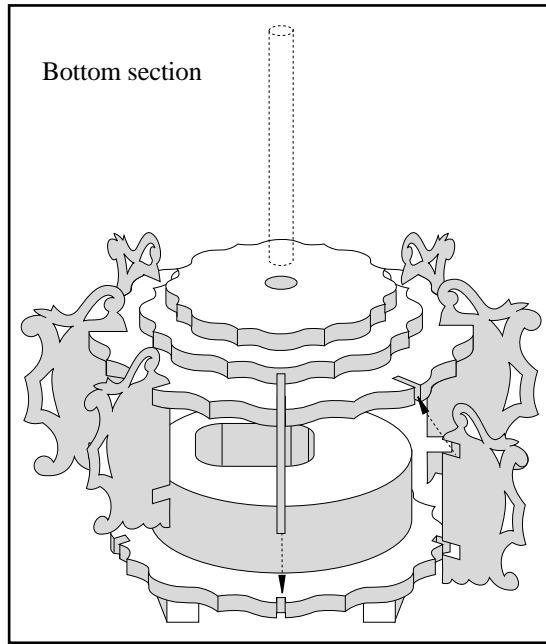

Frame

Stock: 1 1/2"

Circle indicates
position of key and
turntable shafts.



Cut out for music box

Project #7

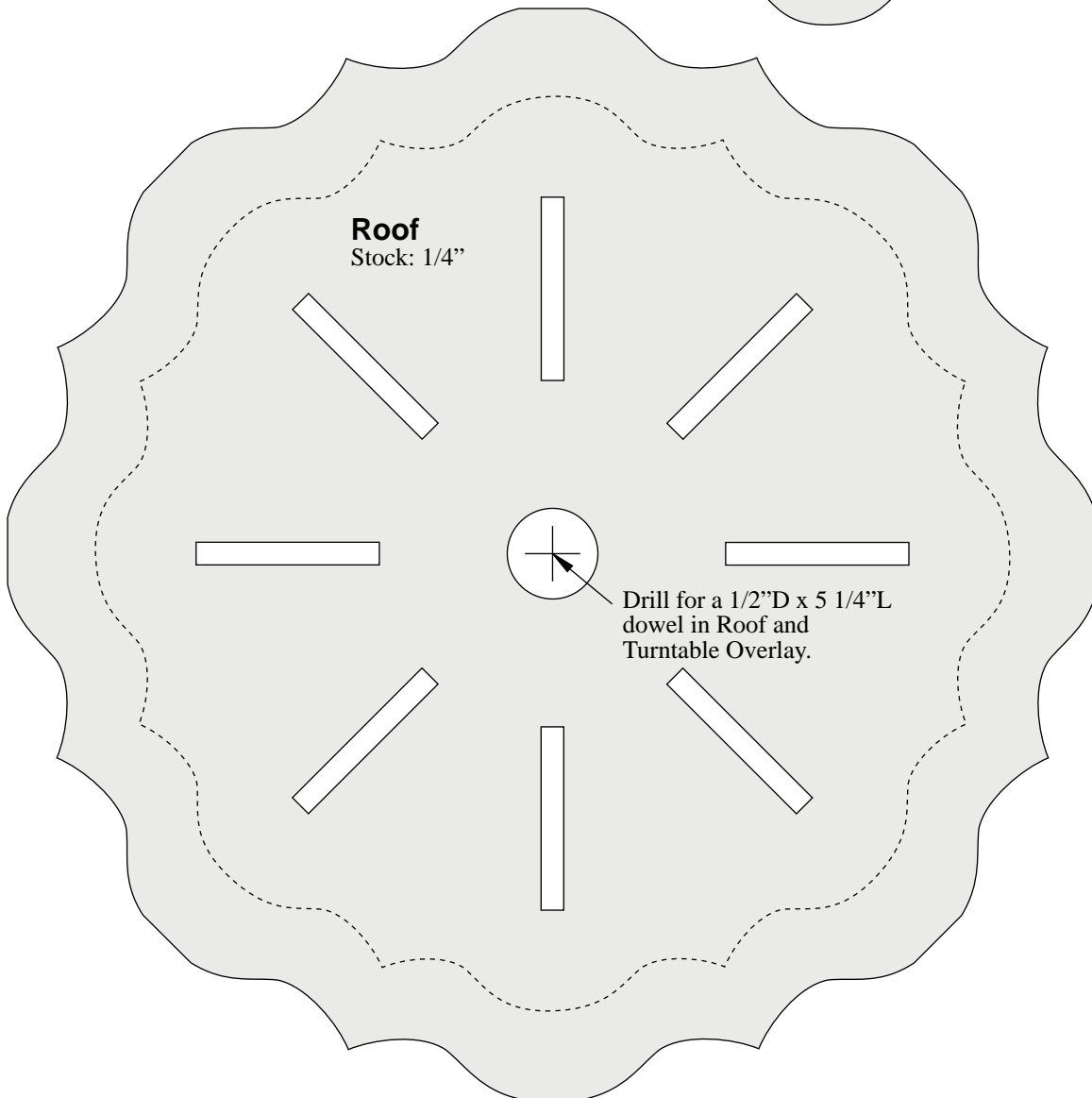
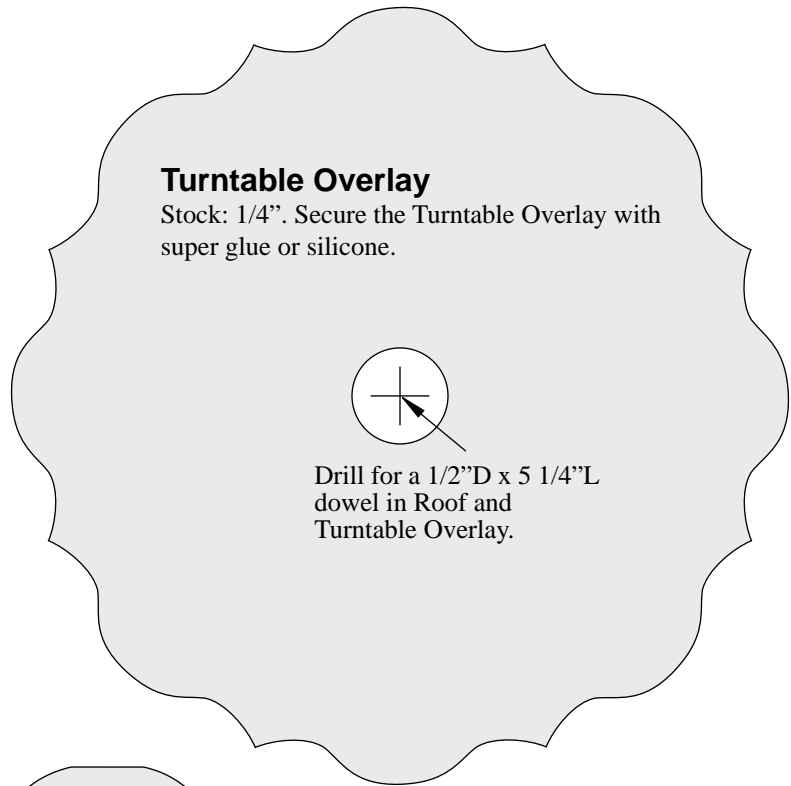
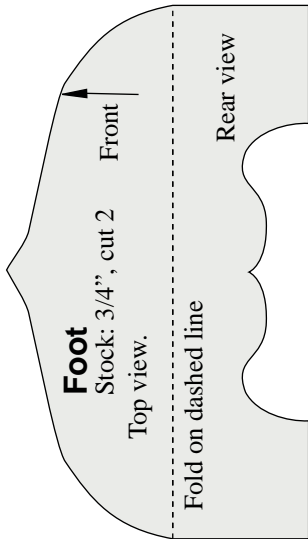

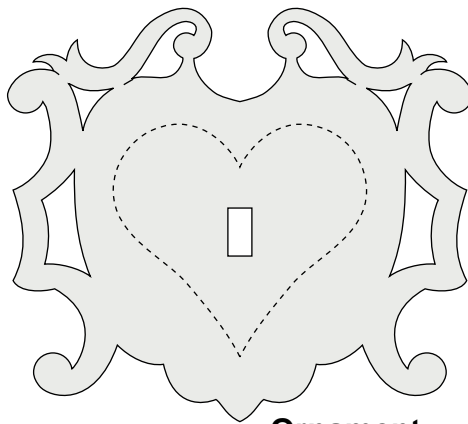
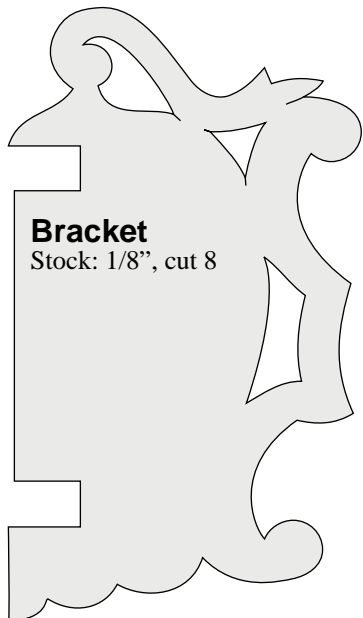
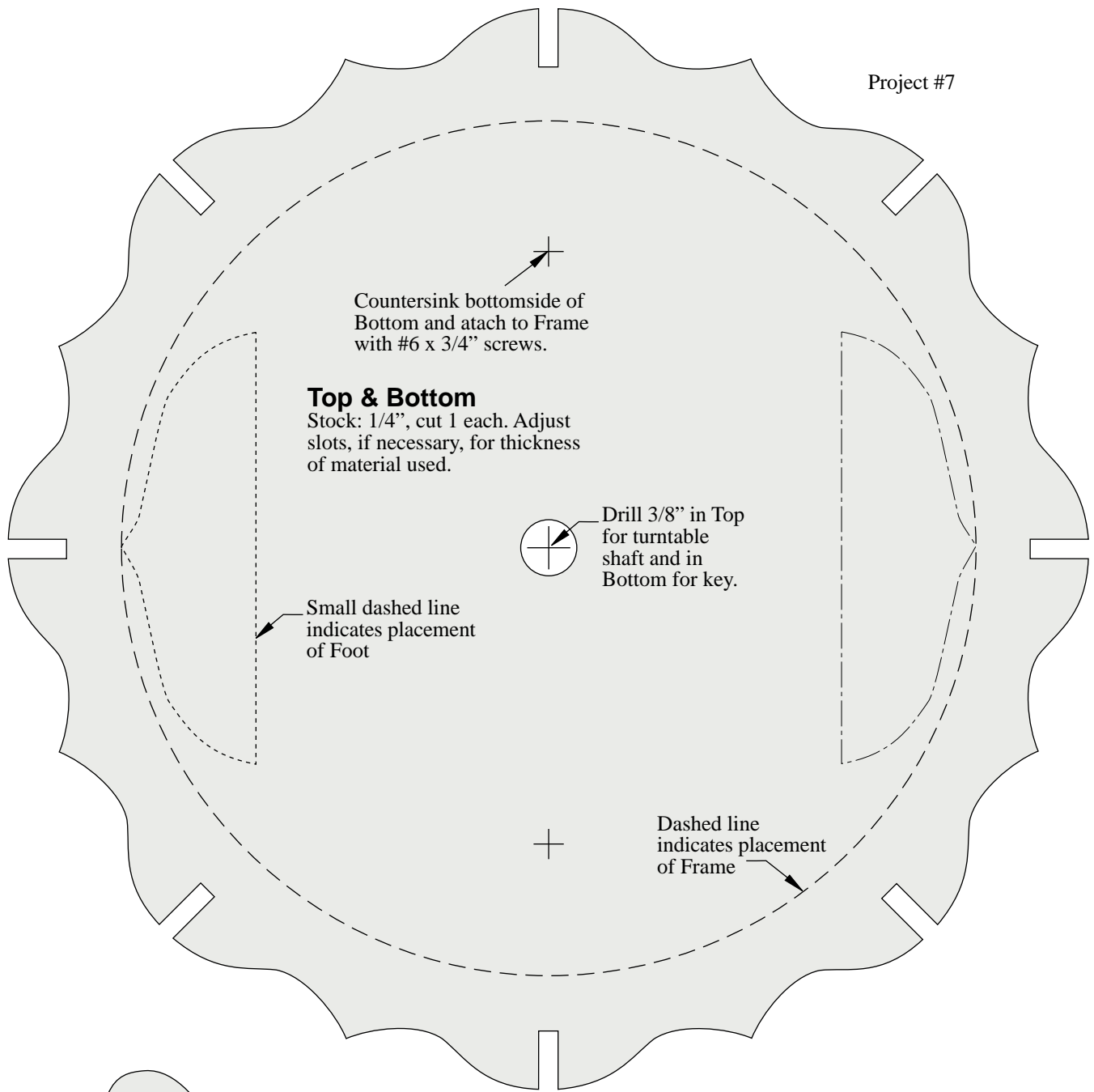

Ornament Overlay
Stock: 1/8", cut 8

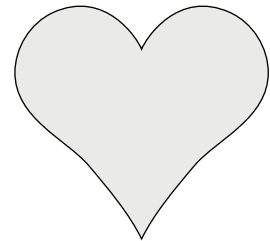

Project #7

22.5° Sand inside
edges 22.5° to fit
in corner of
Crest (A) & (B)
on Roof.

22.5°
Top view

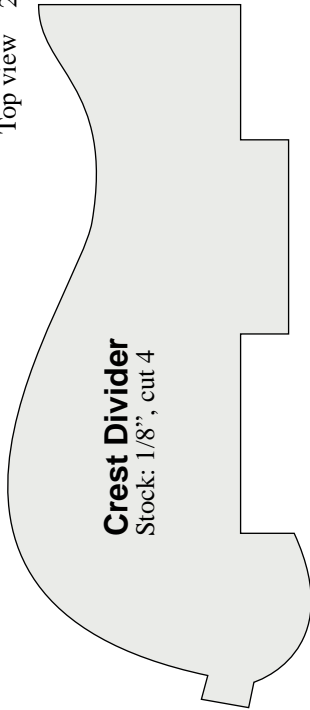

A — Cut this slot for Crest (A)

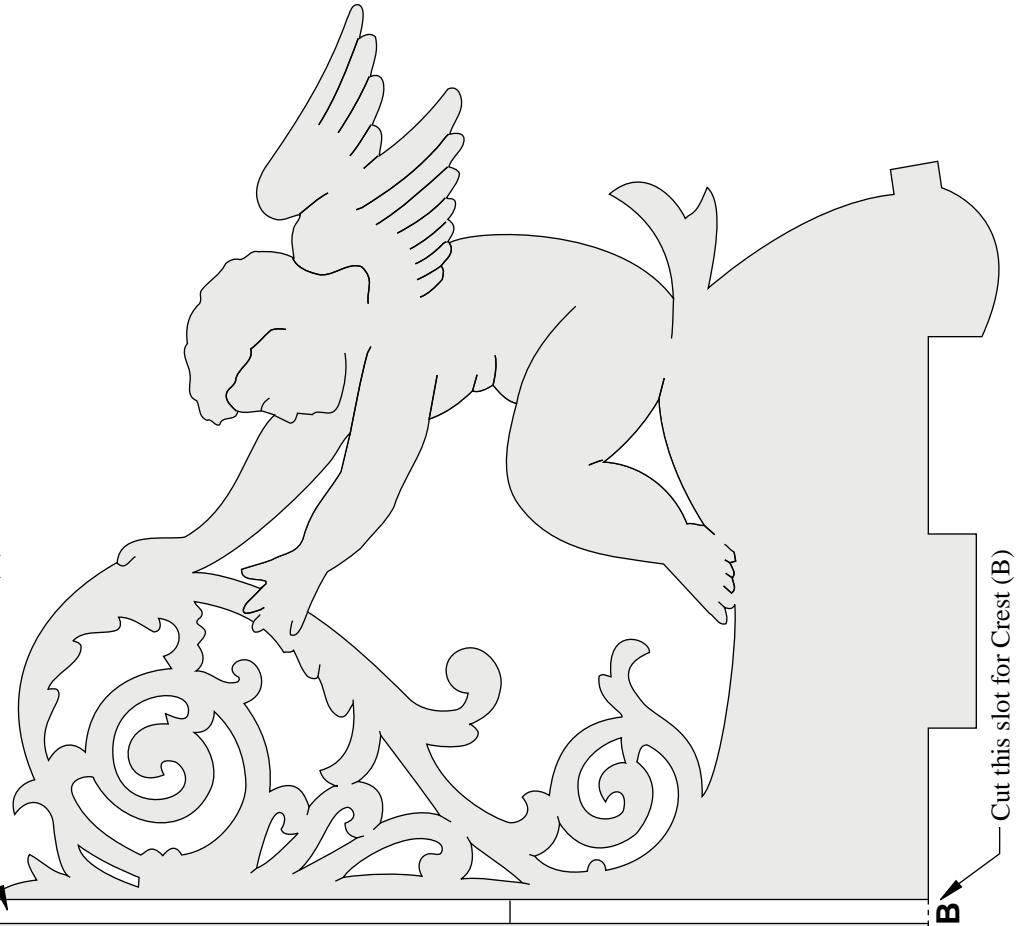

B — Cut this slot for Crest (B)

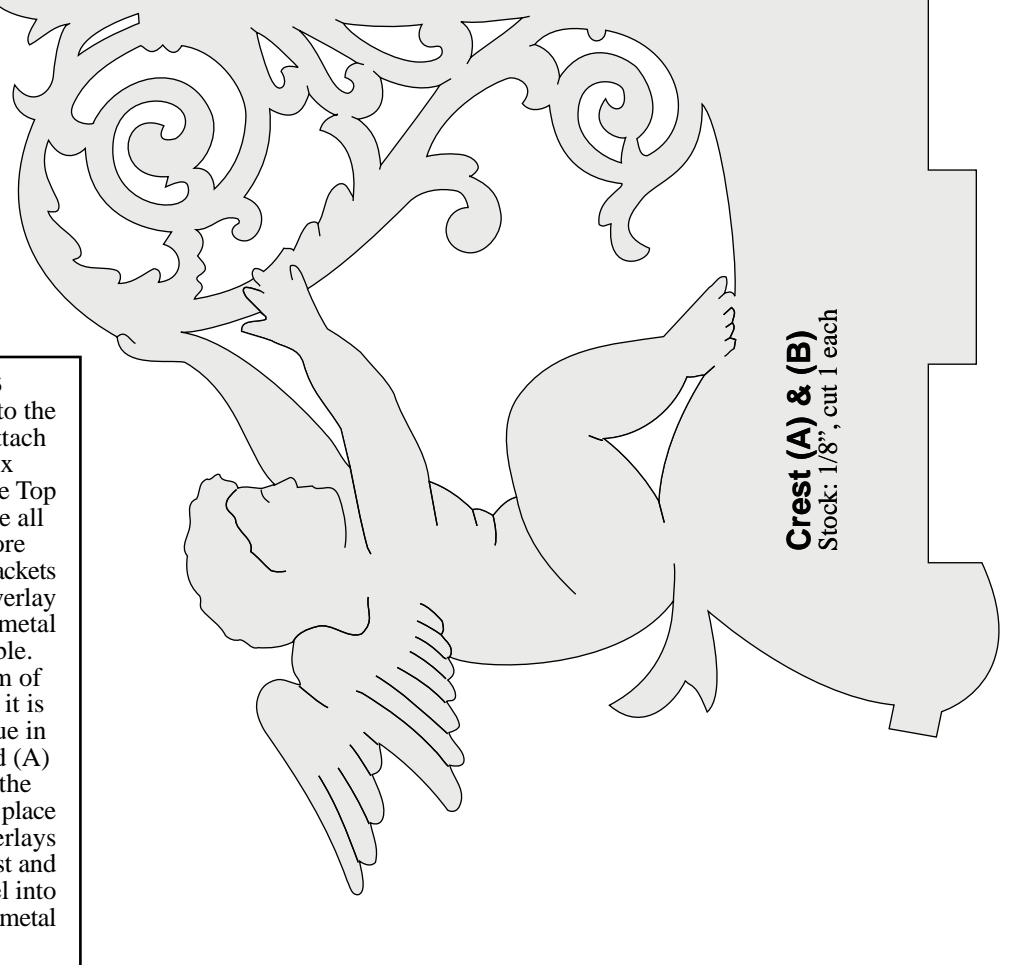

Assembly Instructions

Assemble by first attaching the Feet to the Bottom with glue or silicone. Next attach the Frame, making sure the music box movement is secure in place. Place the Top into position on the Frame, being sure all the slots for the Brackets line up before securing it in place. Then secure the Brackets in place. Now attach the Turntable Overlay to the Turntable, and then secure the metal turntable to the bottom of the Turntable. Next, secure the Ceiling to the bottom of the Roof. Then insert the dowel until it is flush with the top of the Roof and glue in place. Now secure both Crest (B) and (A) into place on the Roof, and then add the Crest Dividers. Secure the Angels into place in the Ceiling, and the Ornament Overlays and Ornaments on the tabs of the Crest and Crest Dividers. Now, secure the dowel into the Turntable assembly, and attach the metal turntable to the movement.

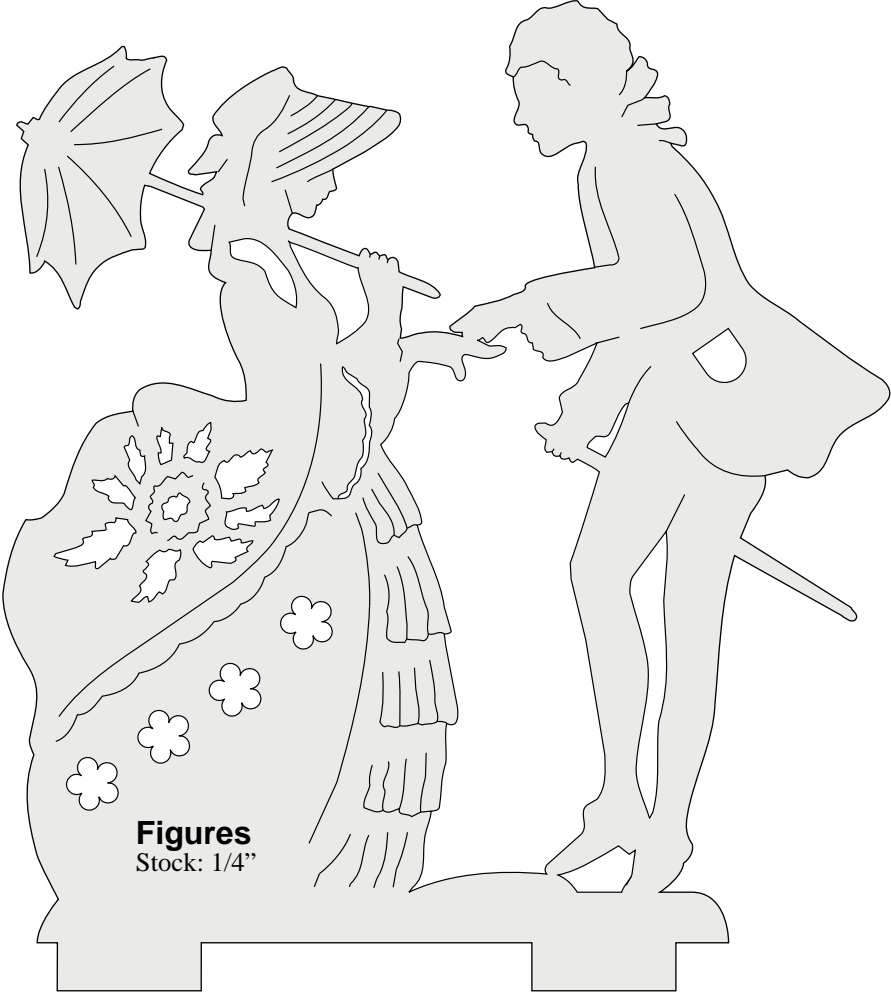
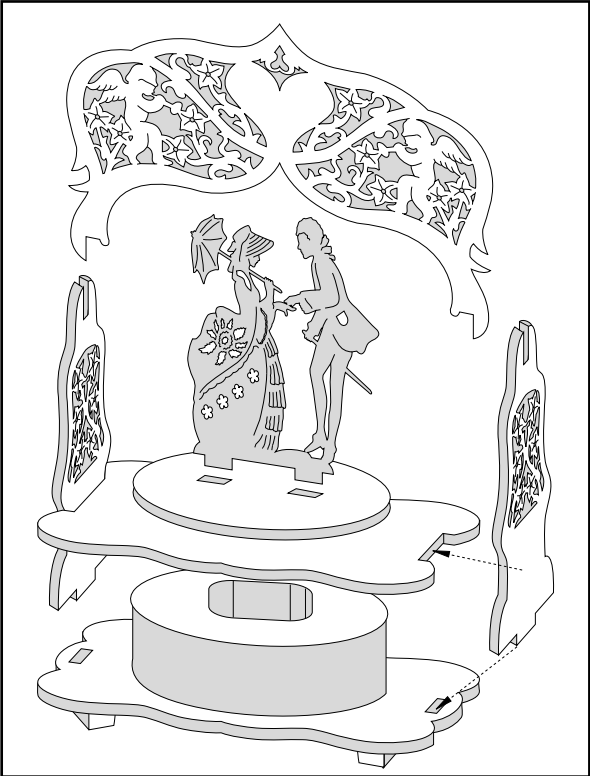

Figures
Stock: 1/4"

Project #8

Turntable

Stock: 1/4", countersink the bottomside with a 1" forstner bit 1/16" deep. Secure the metal turntable with super glue or silicone.

Dashed line indicates position of metal turntable on bottomside.

Adjust slots if necessary for thickness of the material used.

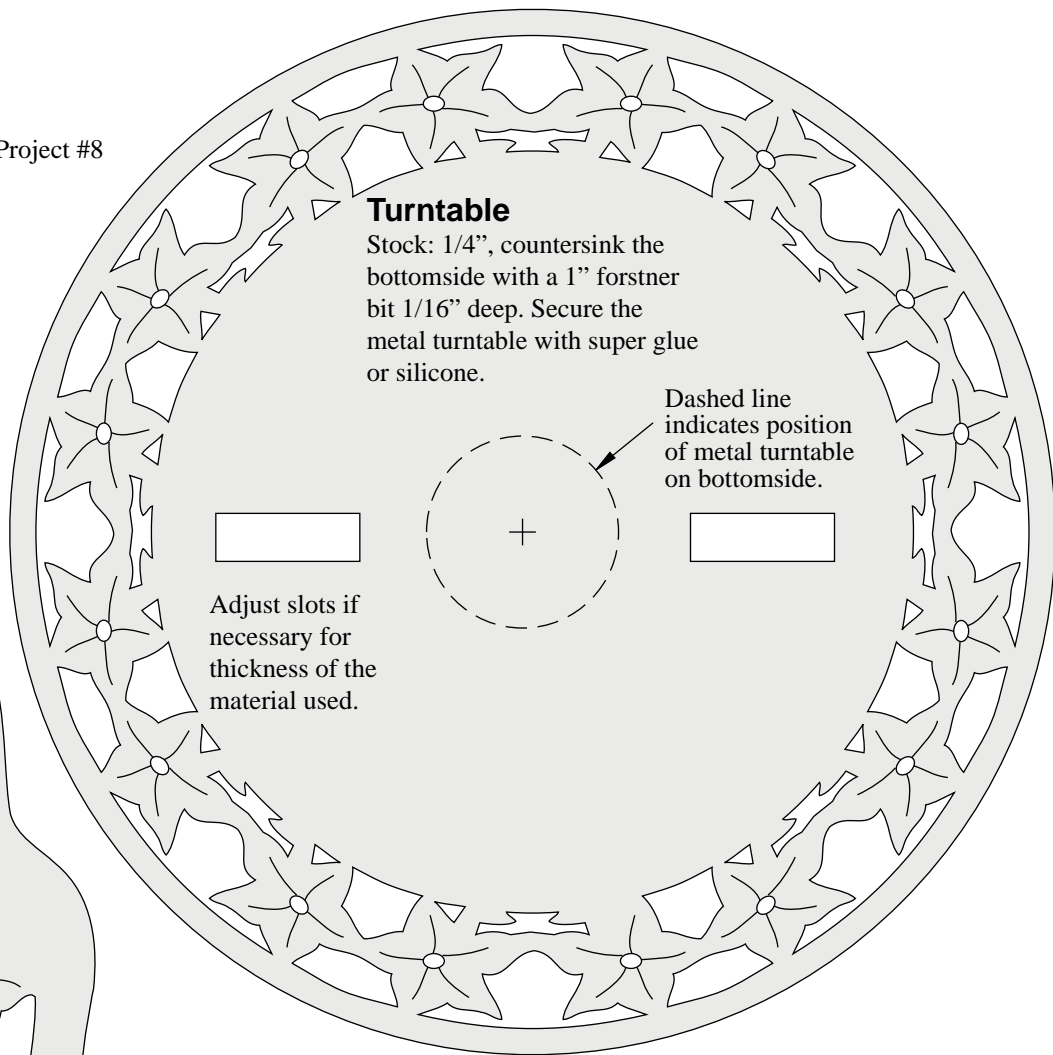

Arch Support

Stock: 1/4", cut 2

Attach to Top with #6 x 5/8" nails and glue.

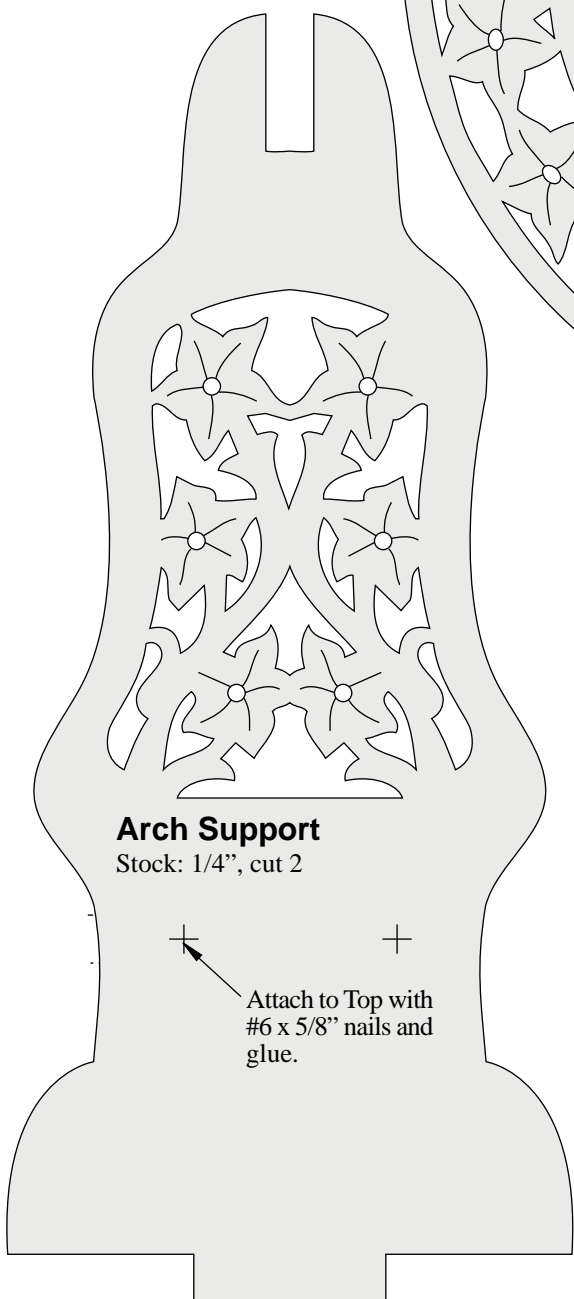

Project #8

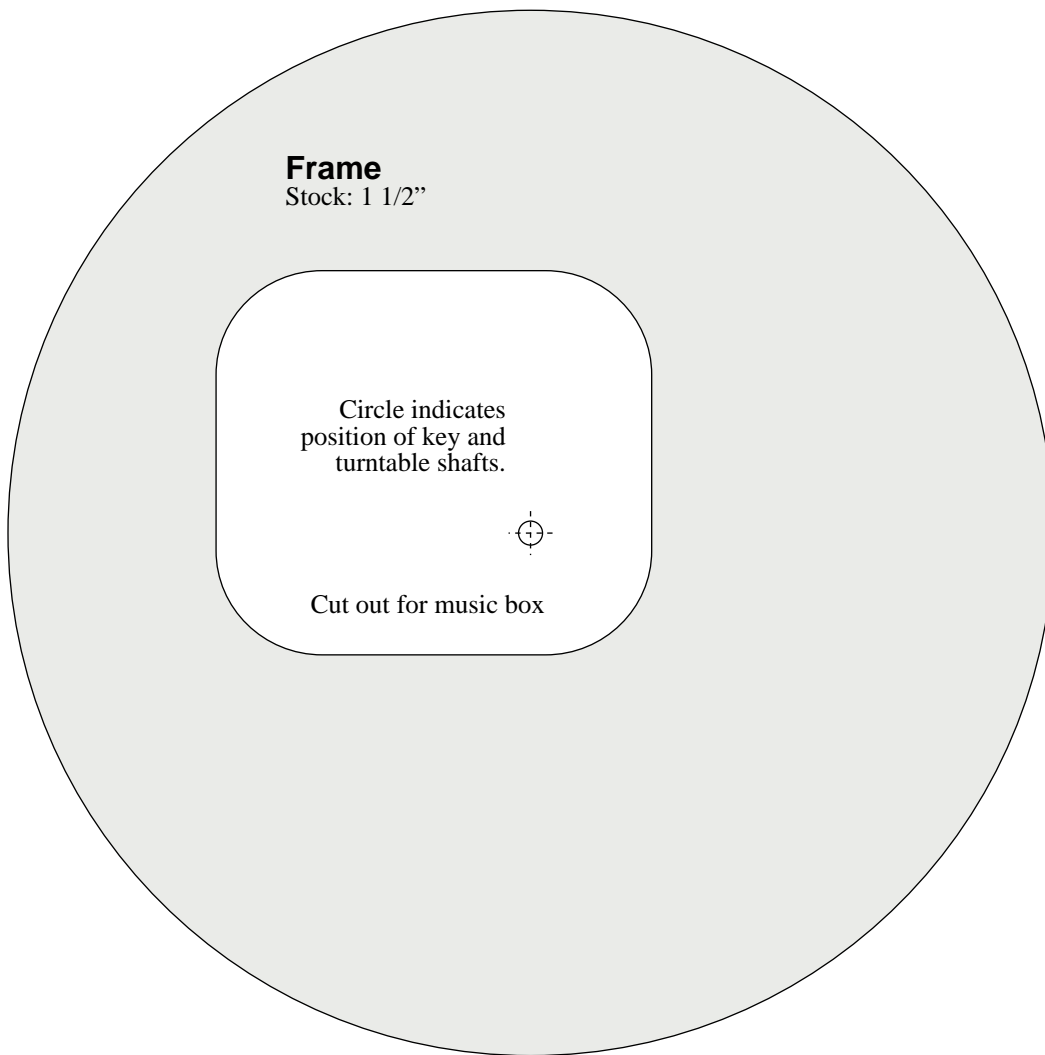
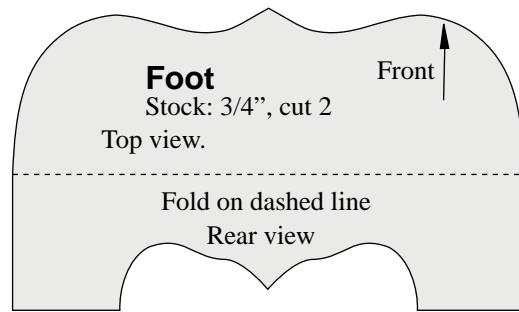

Project #8

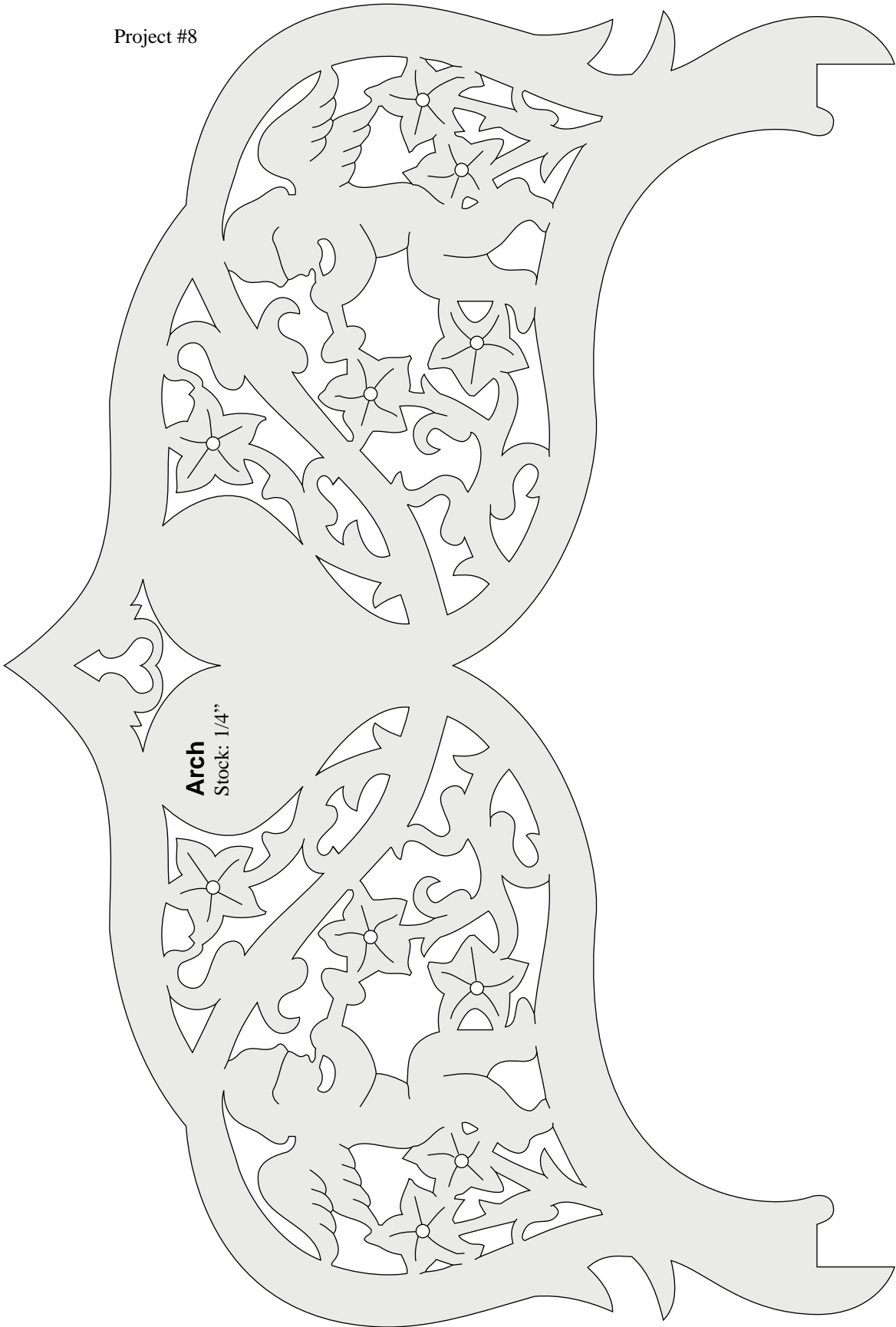

Arch

Stock: 1/4"

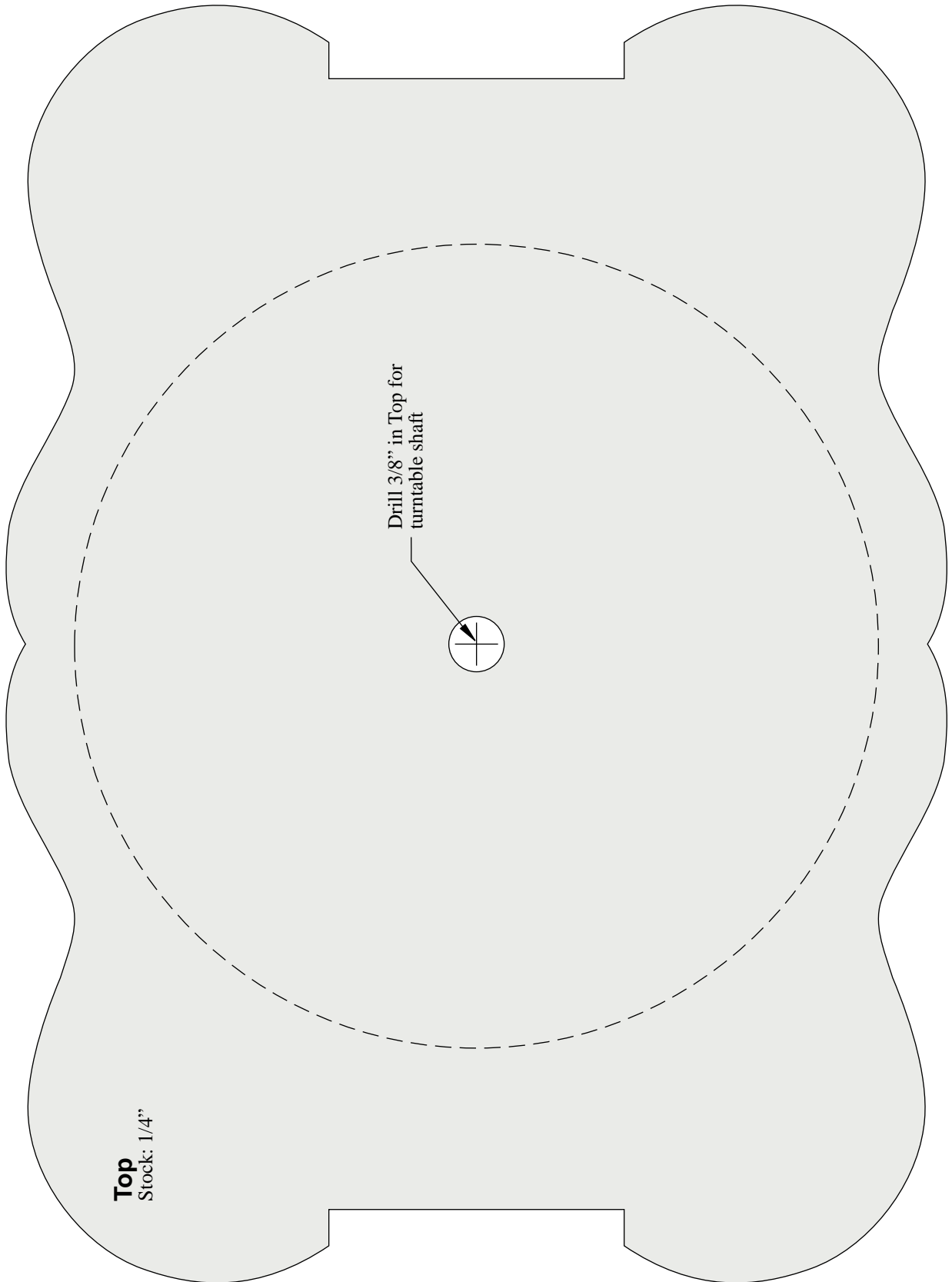

Drill 3/8" in Top for
turntable shaft

Top
Stock: 1/4"

Project #8

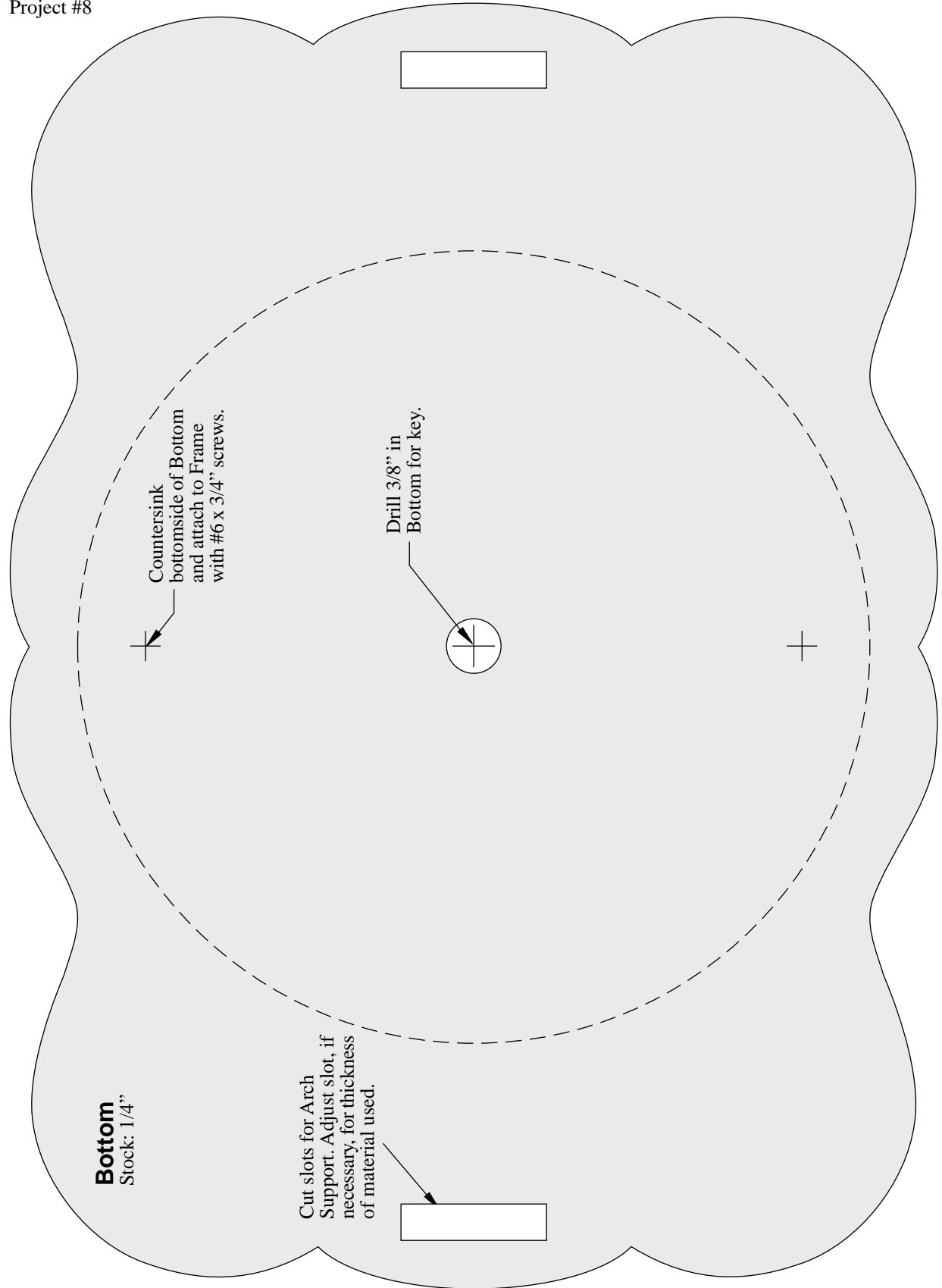

Bottom
Stock: 1/4"

Countersink
bottomsides of Bottom
and attach to Frame
with #6 x 3/4" screws.

Drill 3/8" in
Bottom for key.

Cut slots for Arch
Support. Adjust slot, if
necessary, for thickness
of material used.

Assembly Instructions

Assemble by first attaching one Side Support and one Side to the Bottom. Continue in a clockwise direction with the remaining Side Supports and Sides. Next, secure the Top into position. Now attach the Lid Underlay to the bottom of the Lid. Then secure the Handles, Handle Support, Overlay, and Top Overlay into position.

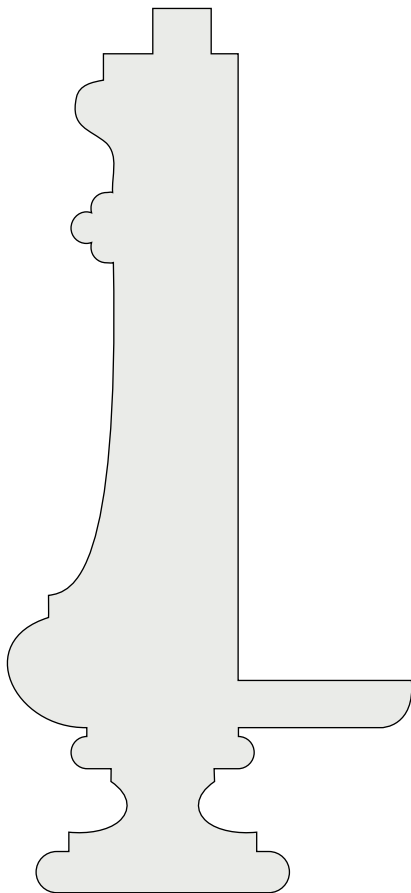
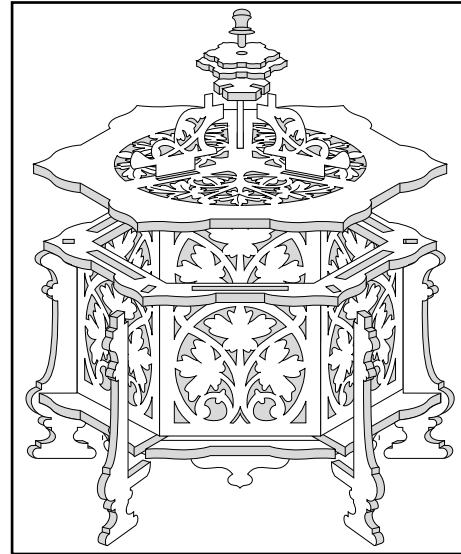

Side Support
Stock: 1/4", cut 6

30° Top view 30°

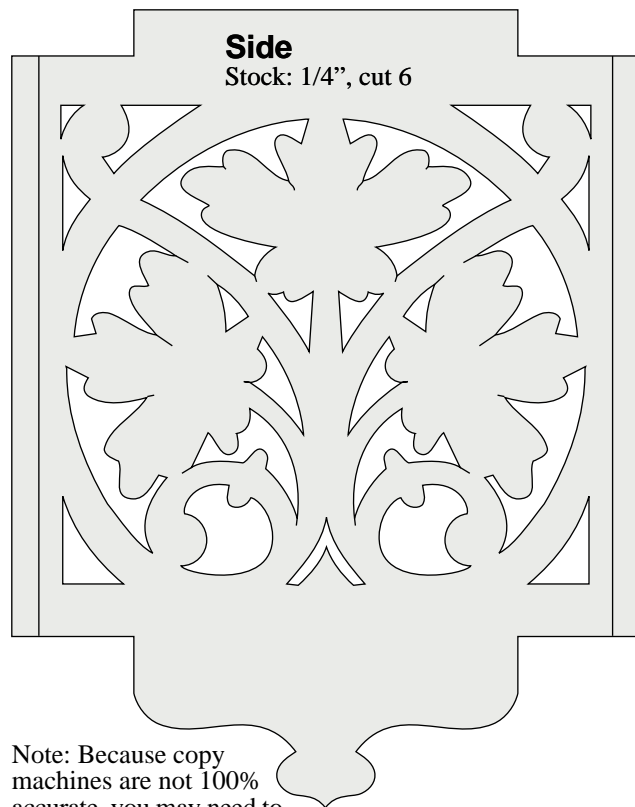

Note: Because copy machines are not 100% accurate, you may need to adjust the width.

Note: Most copy machines are not 100% accurate, which can result in distortion of your pattern pieces. Since this project has several slots and tab connections, it may be necessary to adjust them for an accurate fit.

Project #9

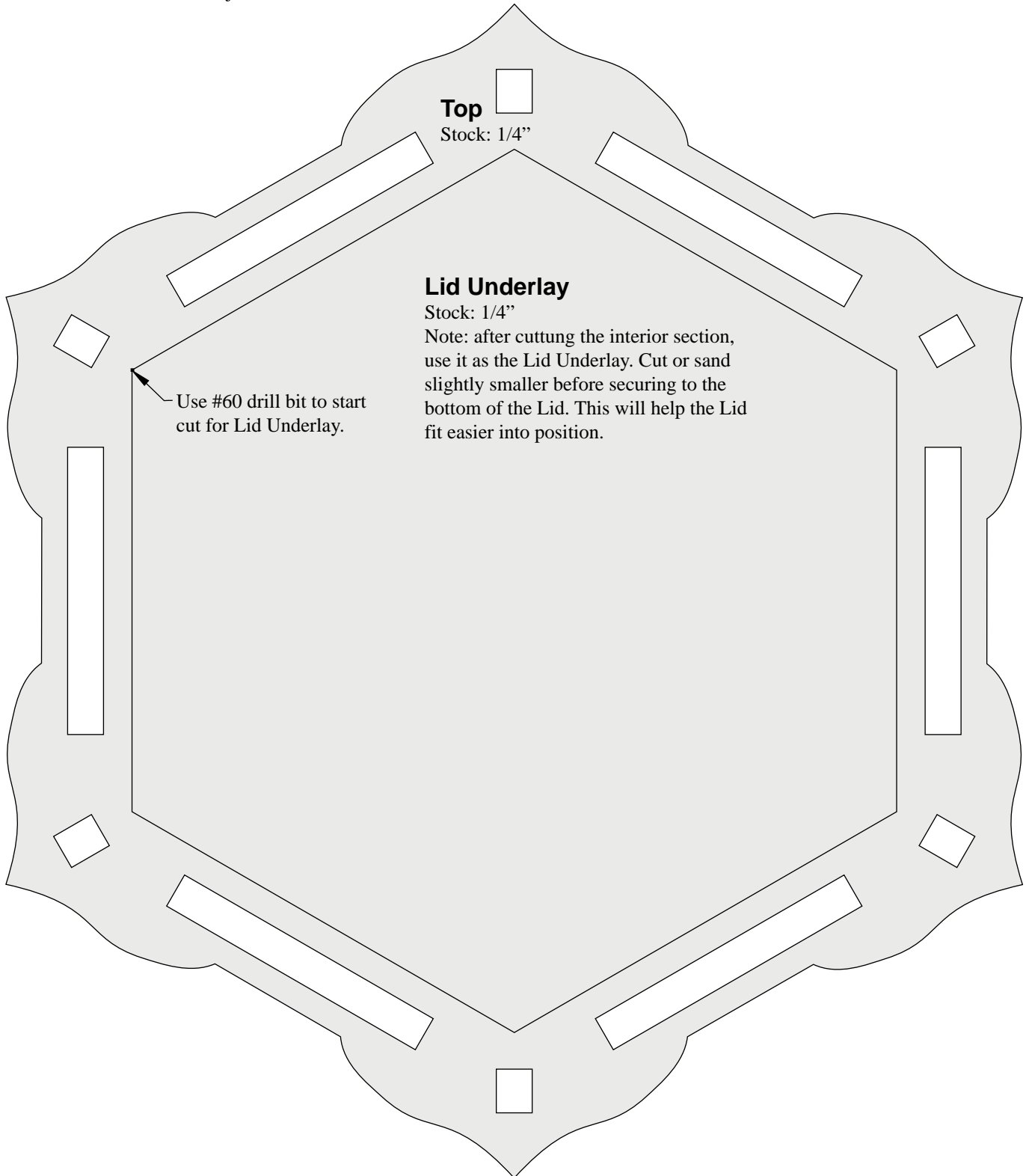

Top Overlay

Stock: 1/8". Attach to Overlay with glue.

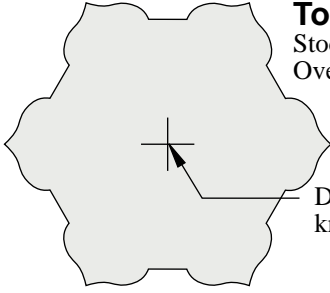

Drill for finial or brass knob of your choice.

Project #9

Bottom

Stock: 1/4"

Dashed line indicates position of music movement.



Drill 3/8" for key

Adjust slots, if necessary, for the thickness of material used.

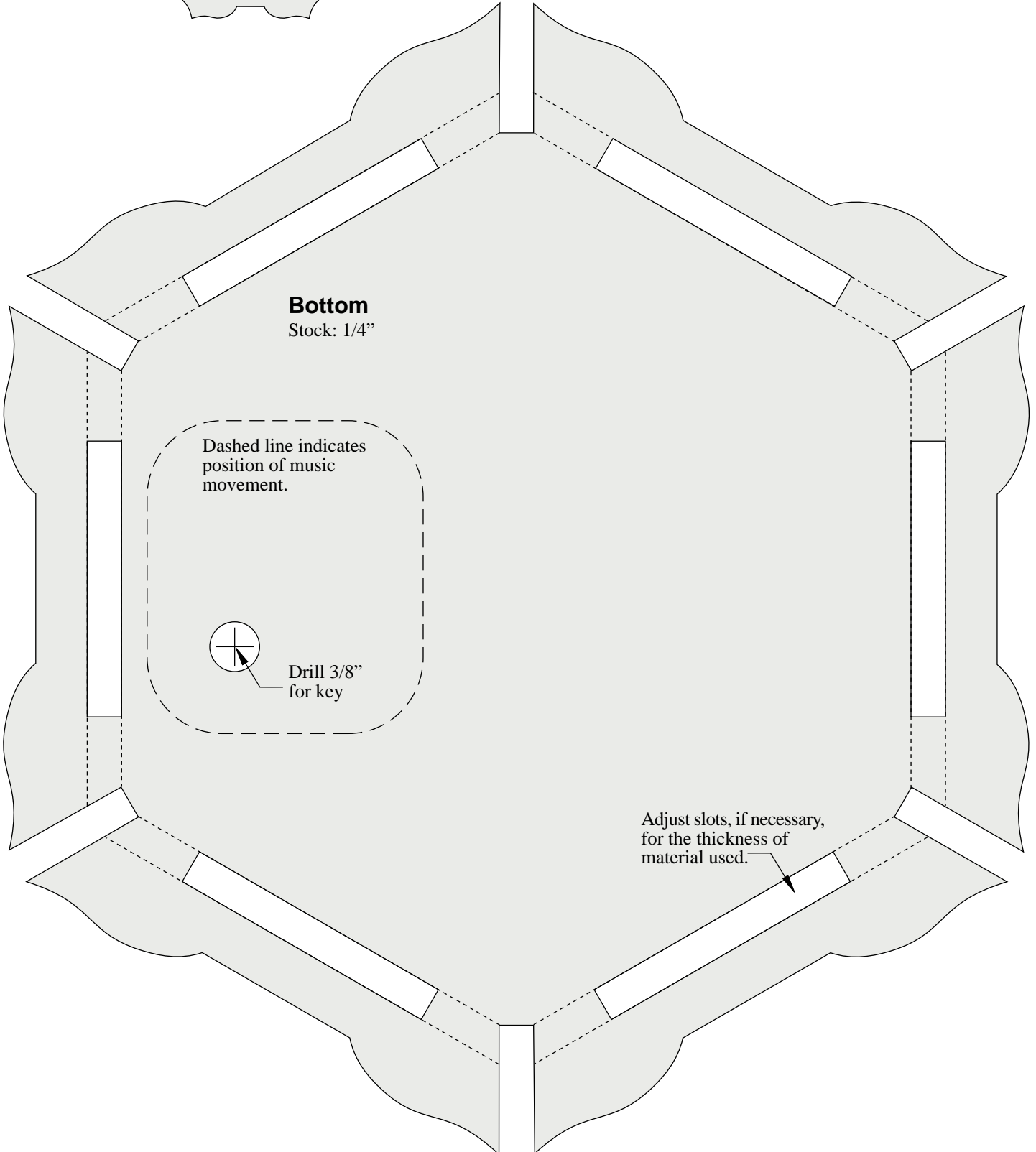

Project #9

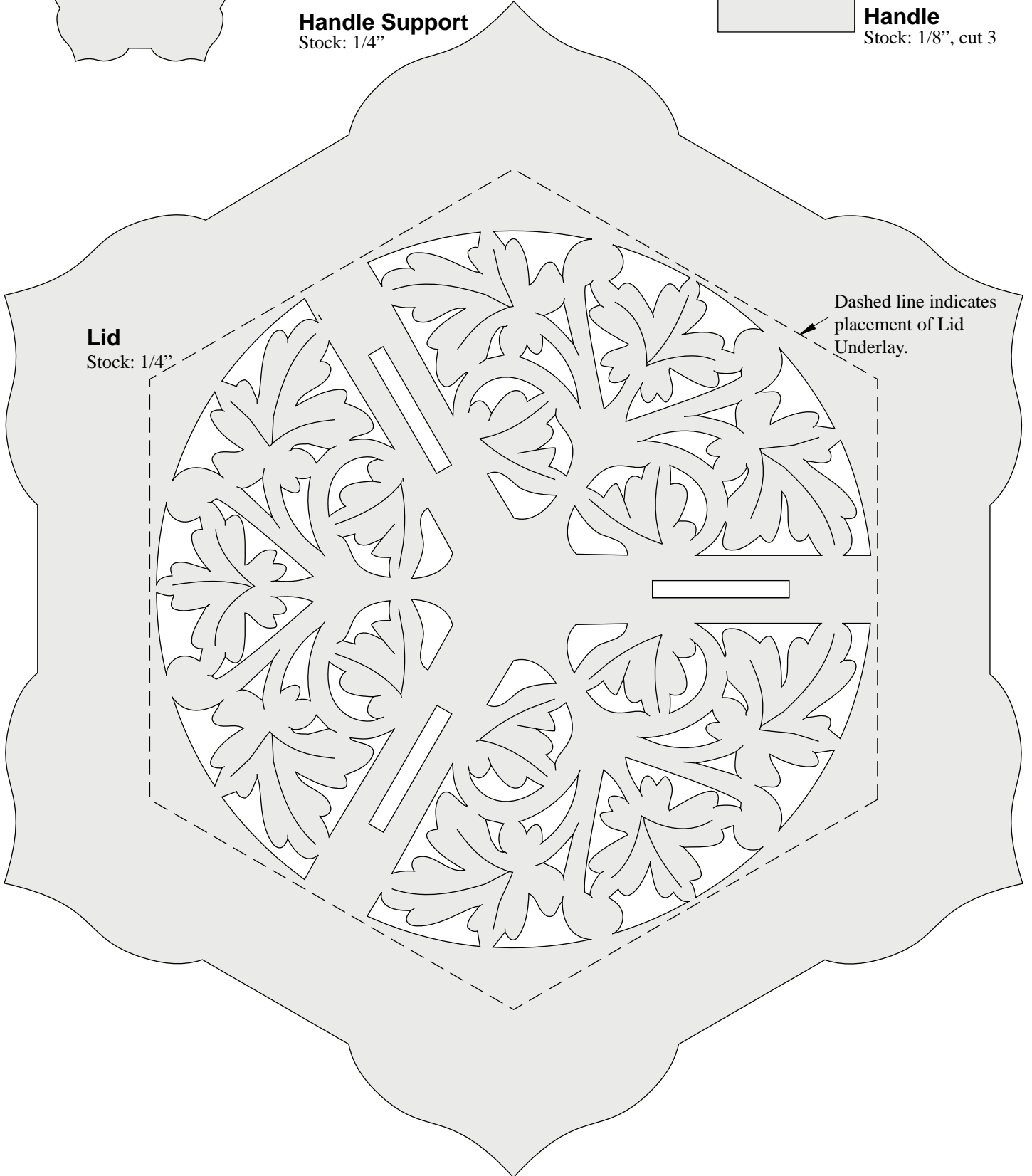
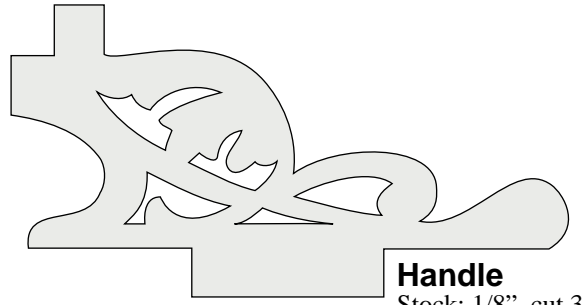
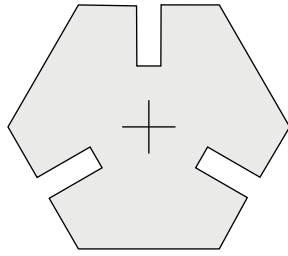
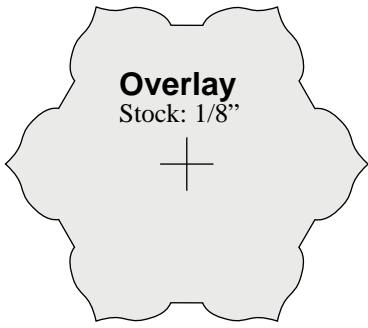

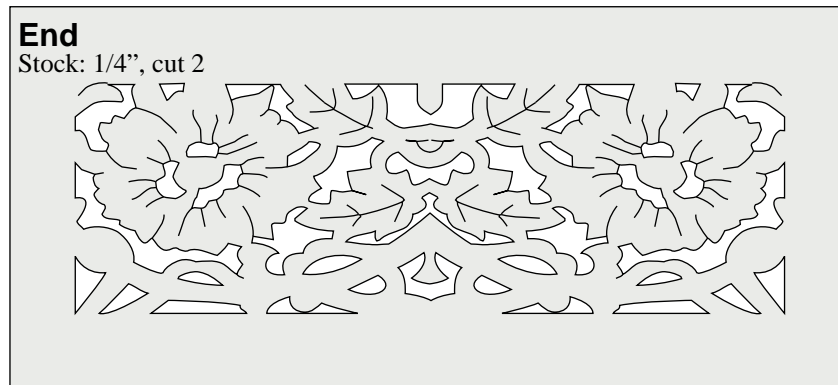
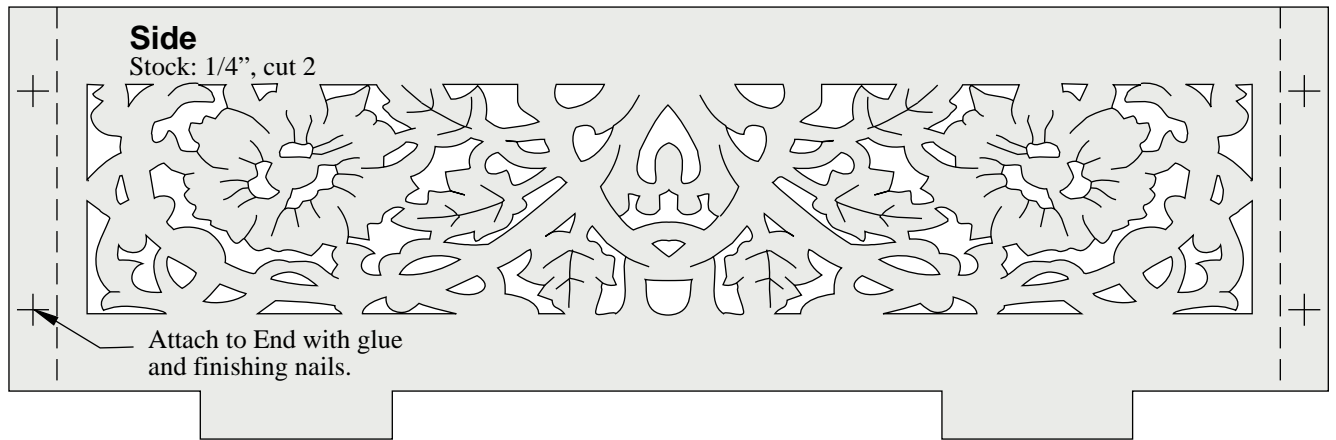
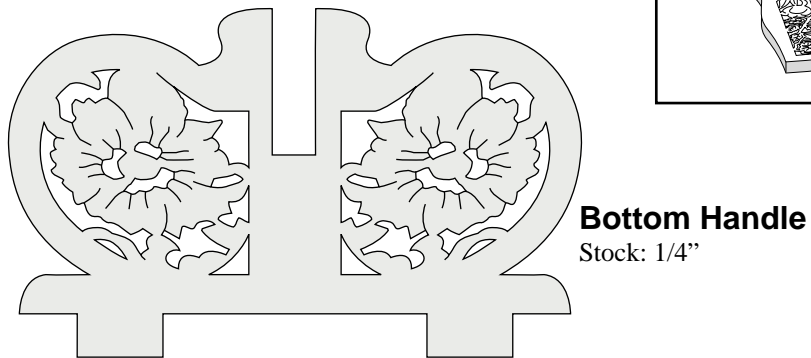
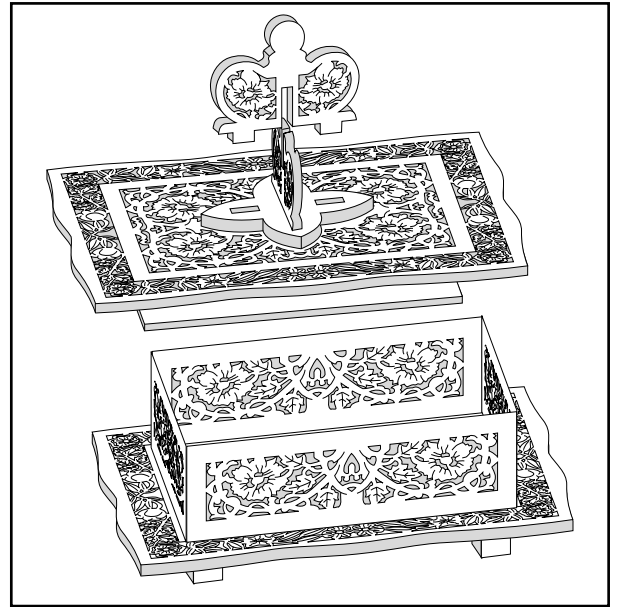
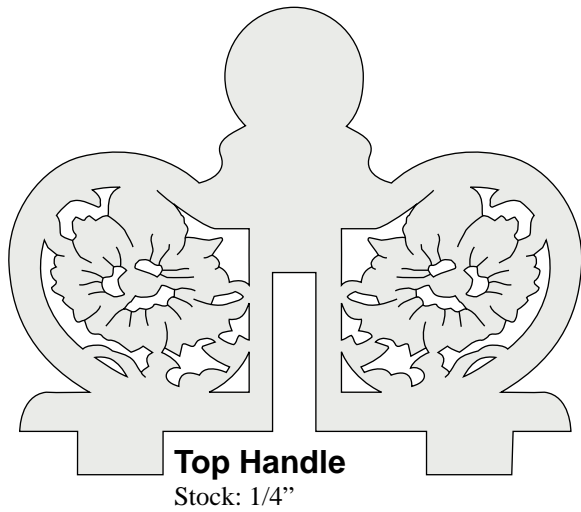

Project #10

Lid Support

Stock: 1/8"
Attach to bottomside of
Lid with glue or silicone.

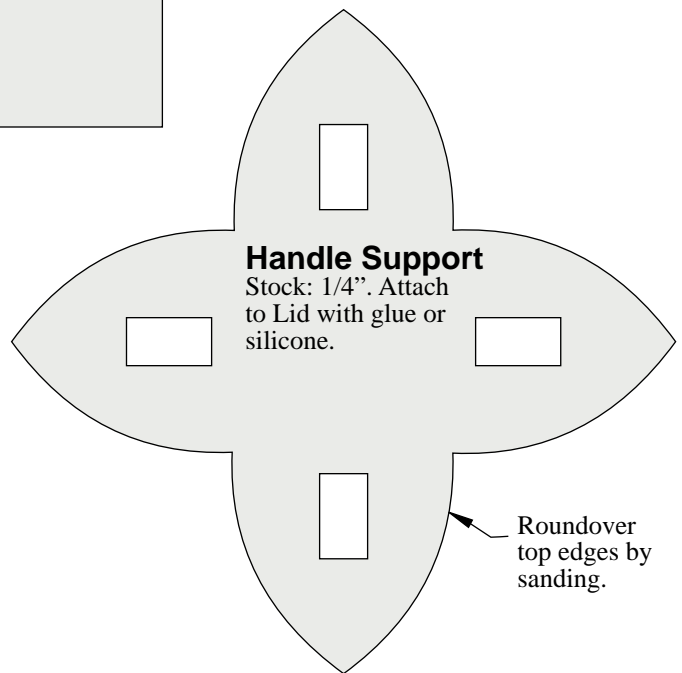
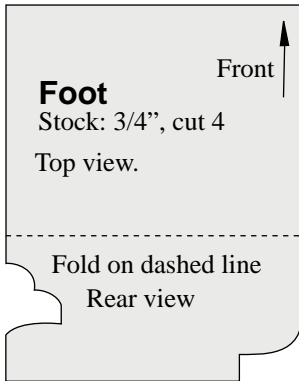
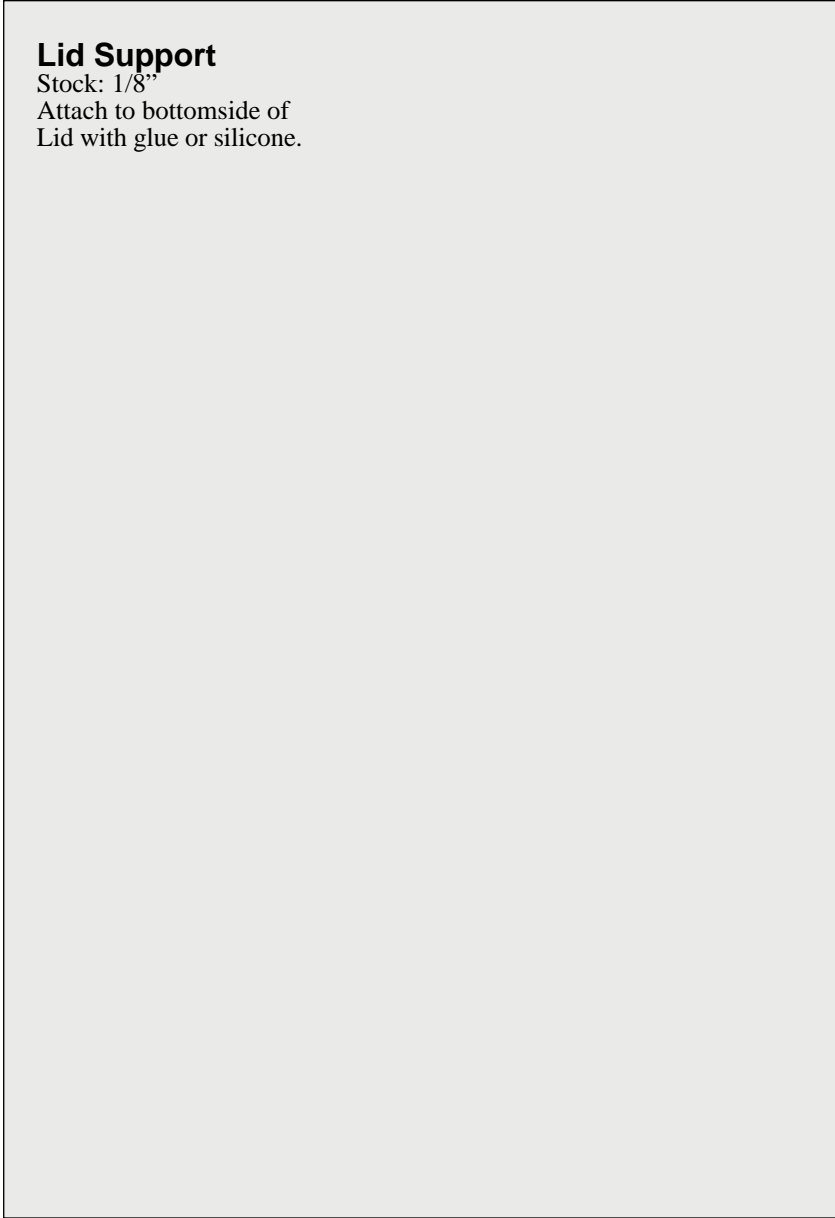

Bottom
Stock: 1/4"

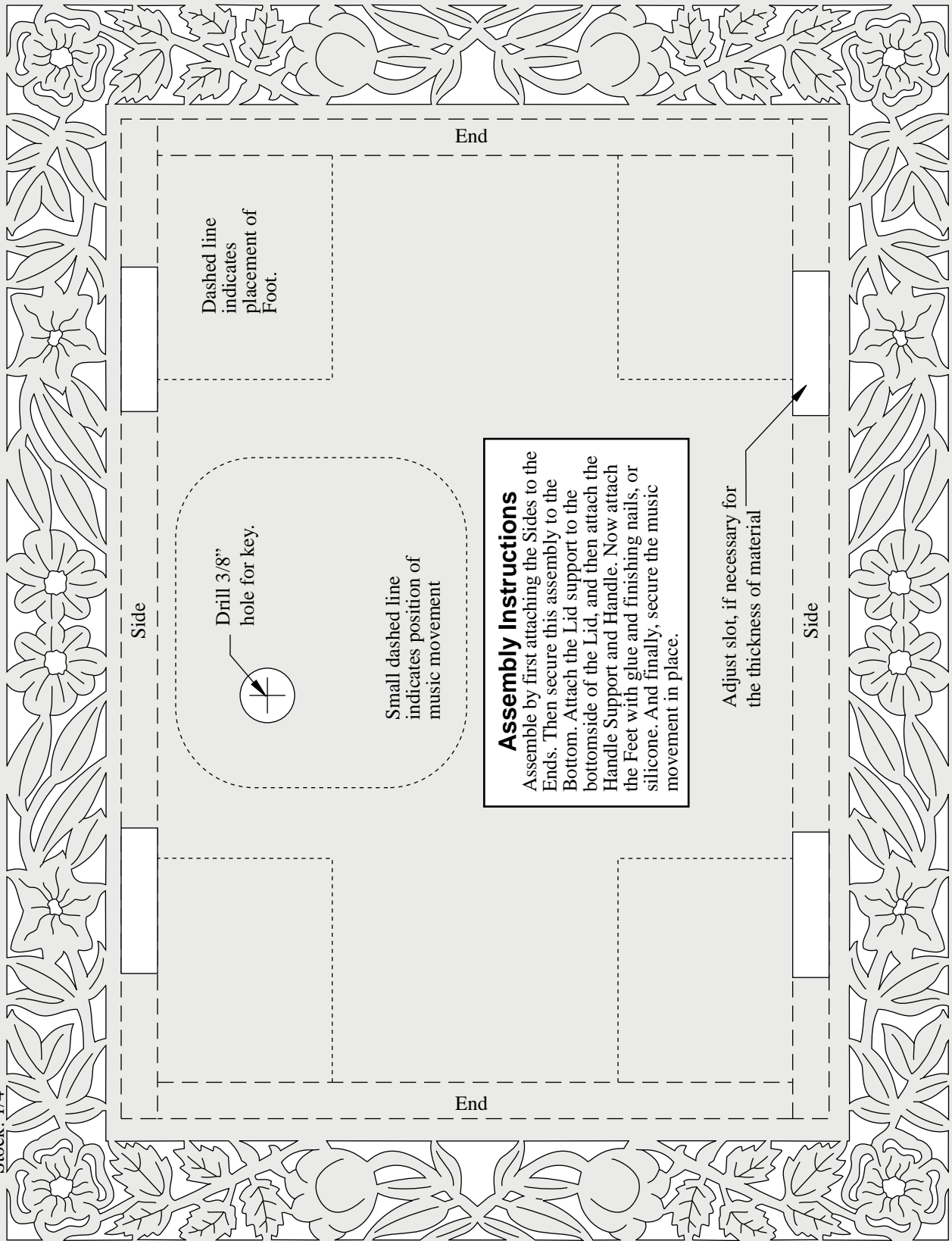

Dashed line indicates placement of Foot.

Drill 3/8" hole for key.

Small dashed line indicates position of music movement

Assembly Instructions
Assemble by first attaching the Sides to the Ends. Then secure this assembly to the Bottom. Attach the Lid support to the bottomside of the Lid, and then attach the Handle Support and Handle. Now attach the Feet with glue and finishing nails, or silicone. And finally, secure the music movement in place.

Adjust slot, if necessary for the thickness of material

Side

End

Side

End



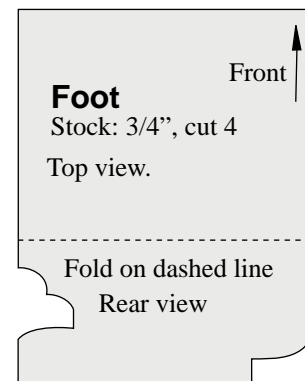
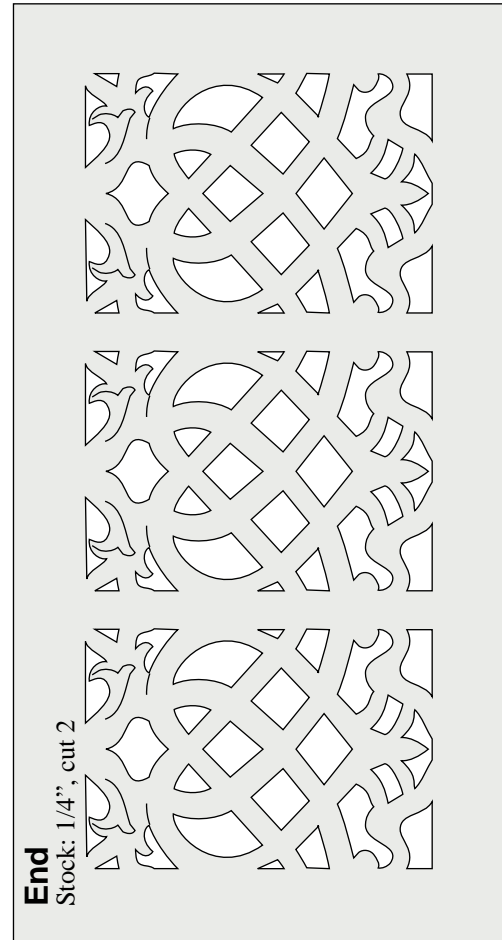
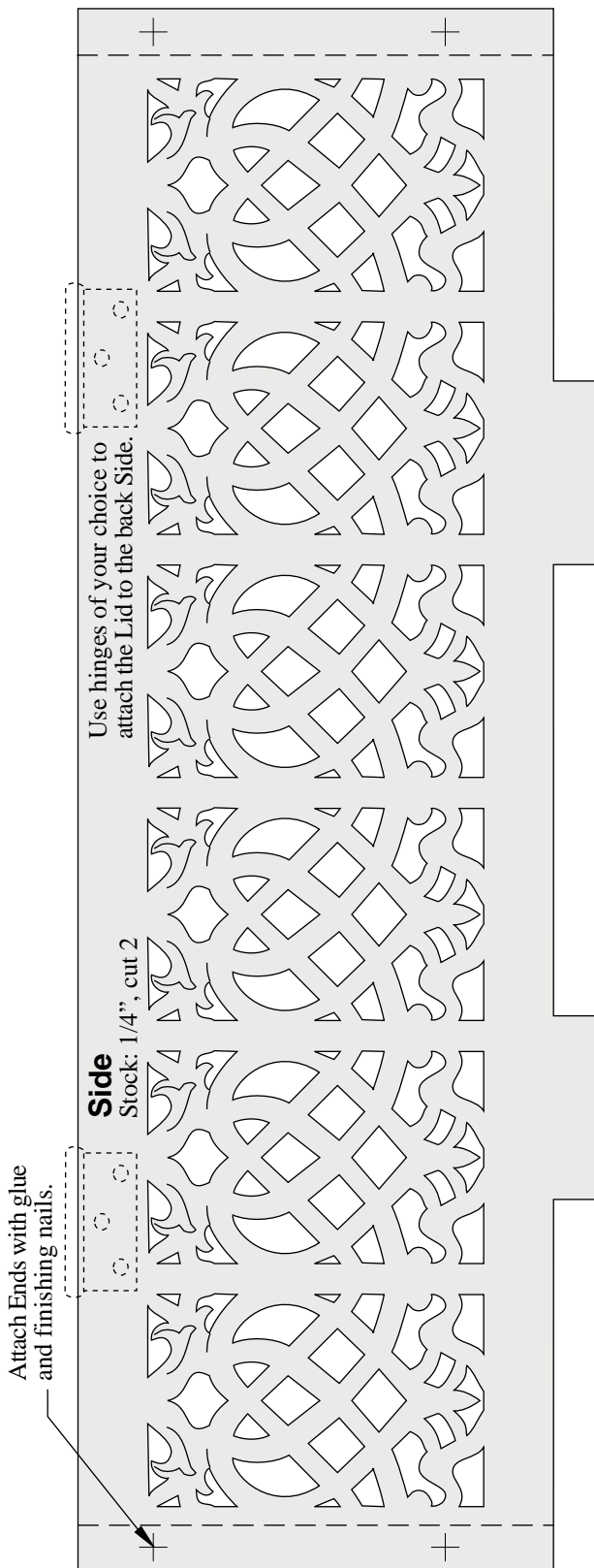
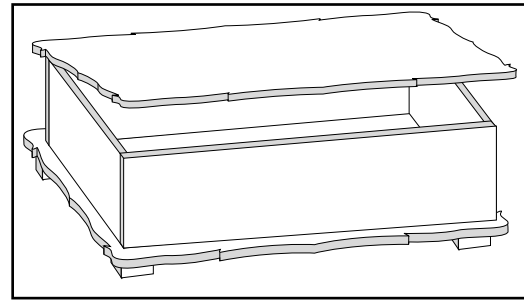

Lid
Stock: 1/4

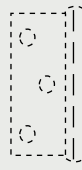

Use hinges of your choice to attach the Lid to the back Side.

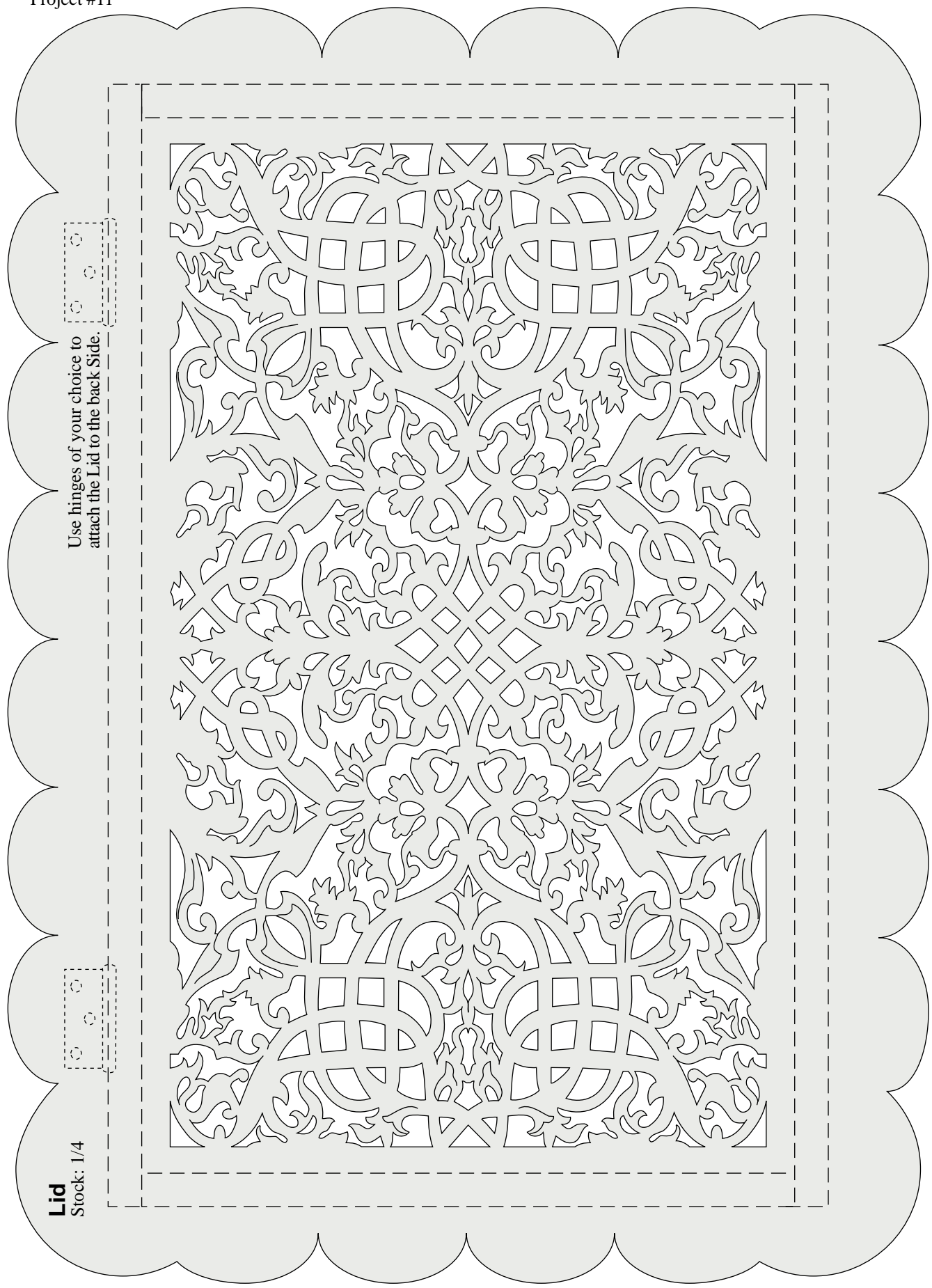
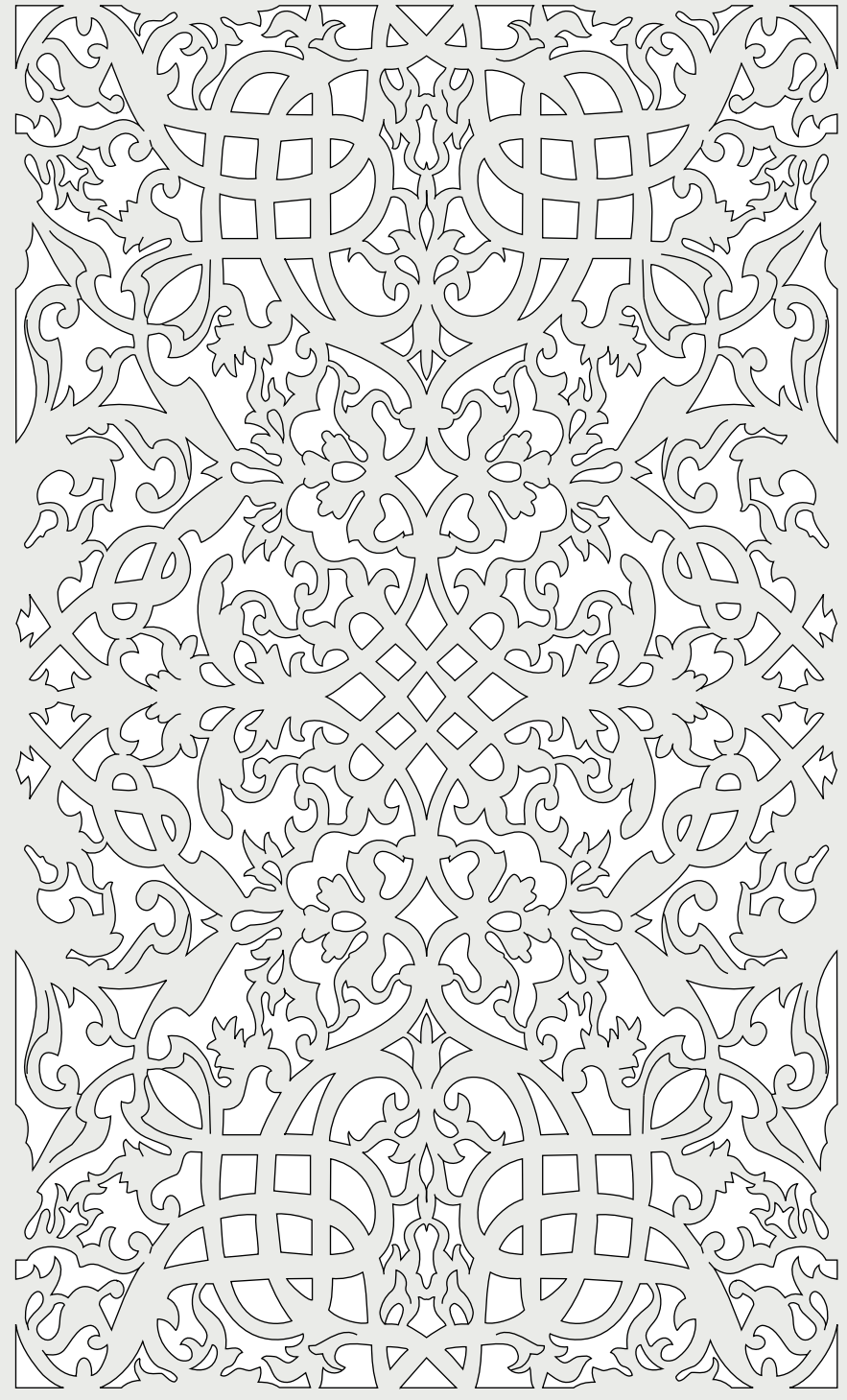

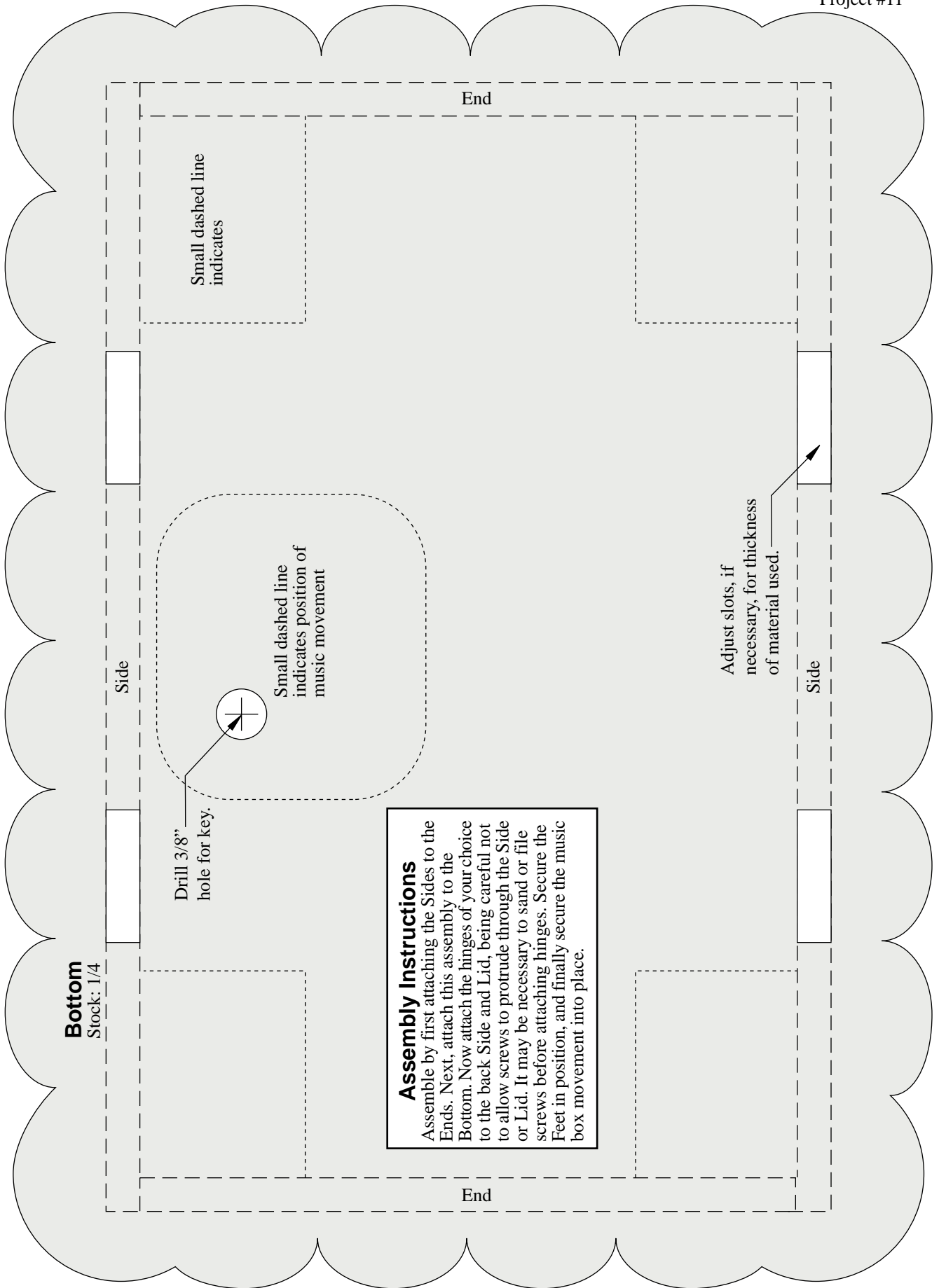

Bottom
Stock: 1/4

Drill 3/8"
hole for key.

Small dashed line
indicates

Small dashed line
indicates position of
music movement

Assembly Instructions
Assemble by first attaching the Sides to the Ends. Next, attach this assembly to the Bottom. Now attach the hinges of your choice to the back Side and Lid, being careful not to allow screws to protrude through the Side or Lid. It may be necessary to sand or file screws before attaching hinges. Secure the Feet in position, and finally secure the music box movement into place.

Adjust slots, if
necessary, for thickness
of material used.

Side

Side

End

End



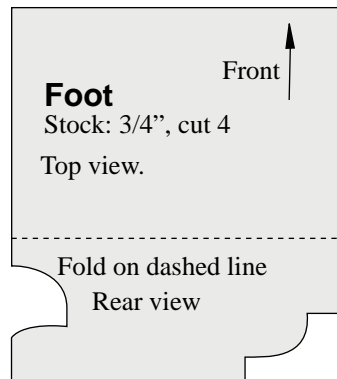
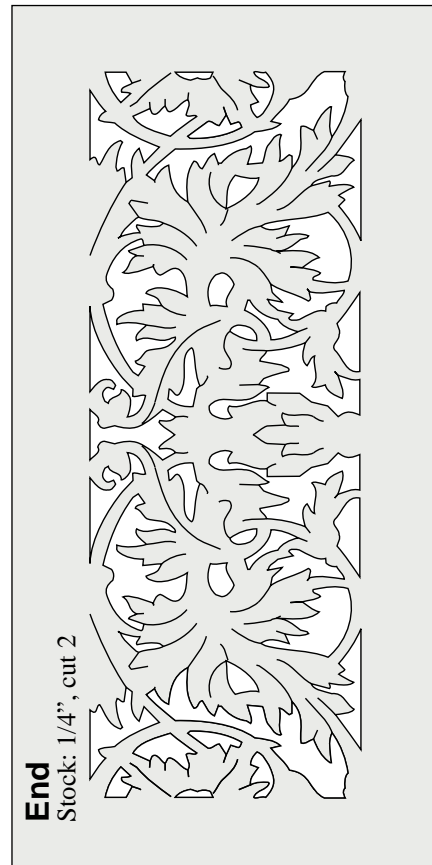
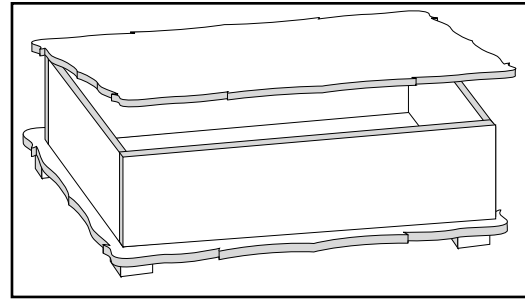
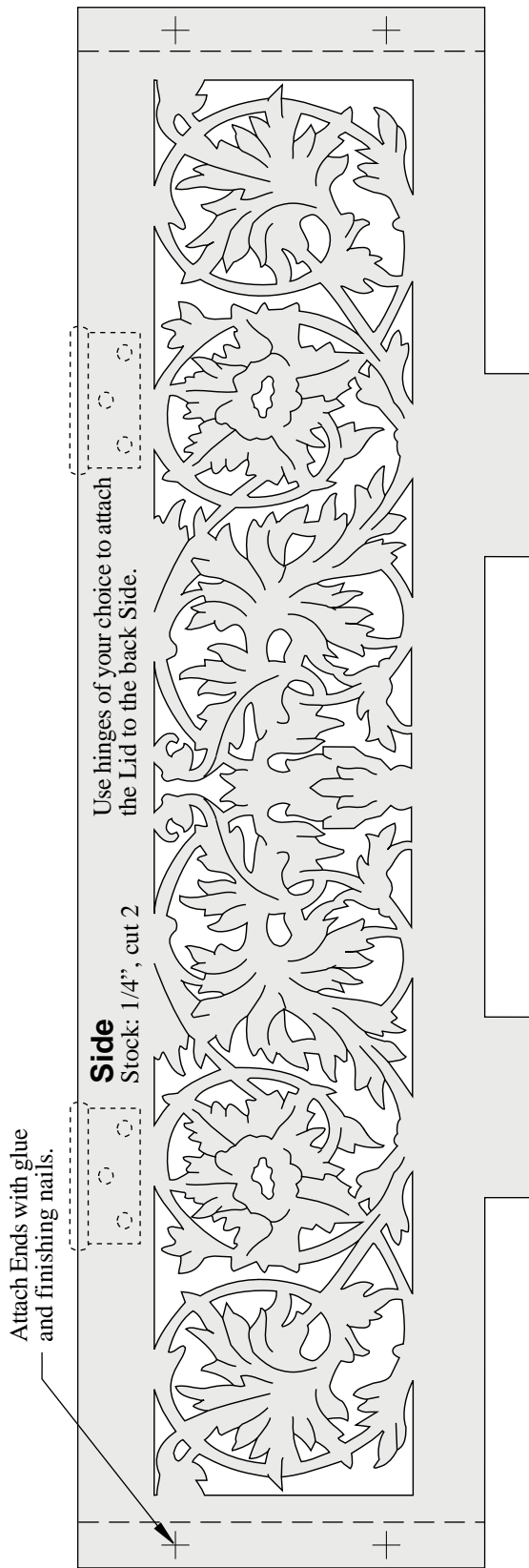

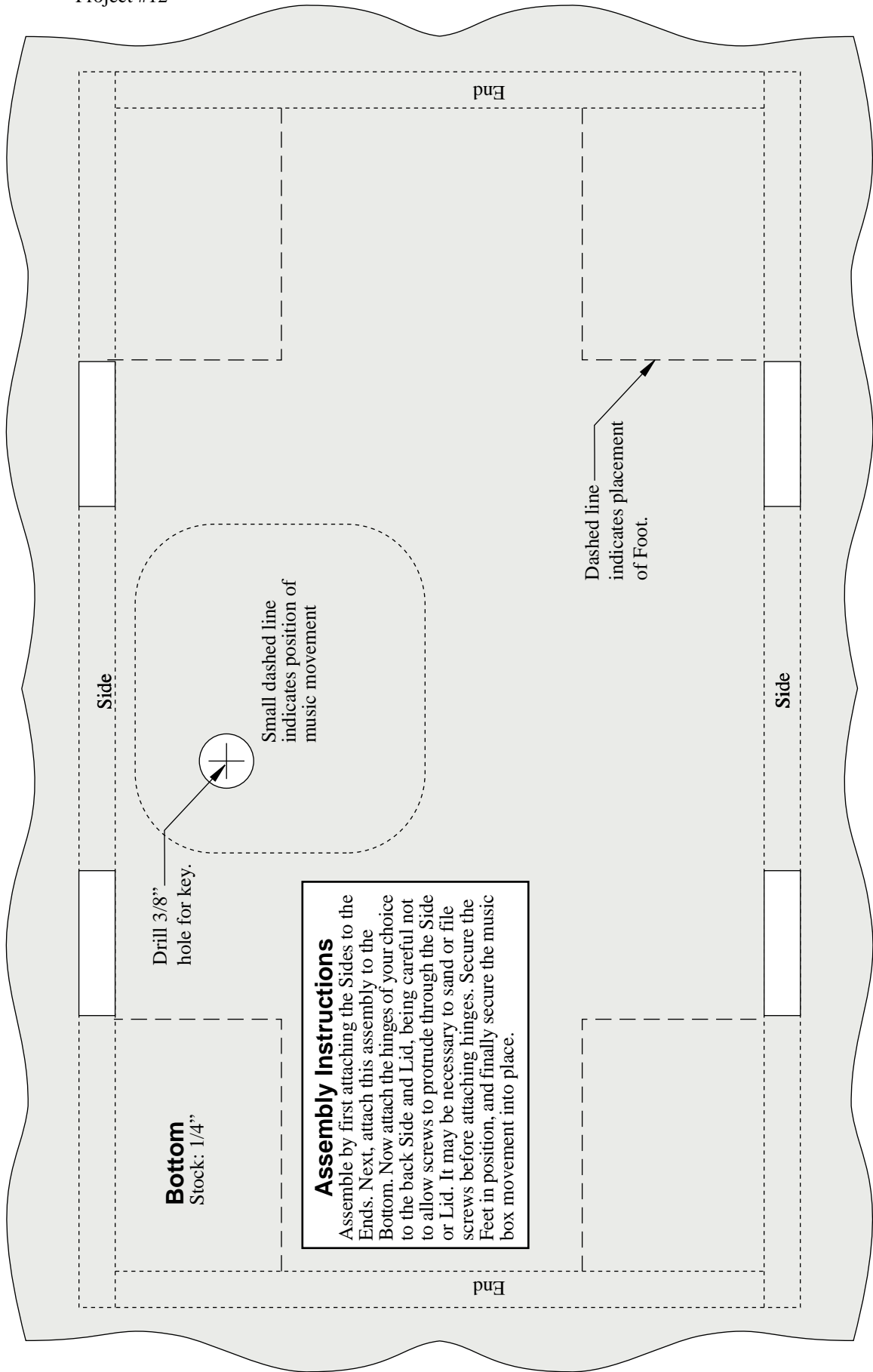

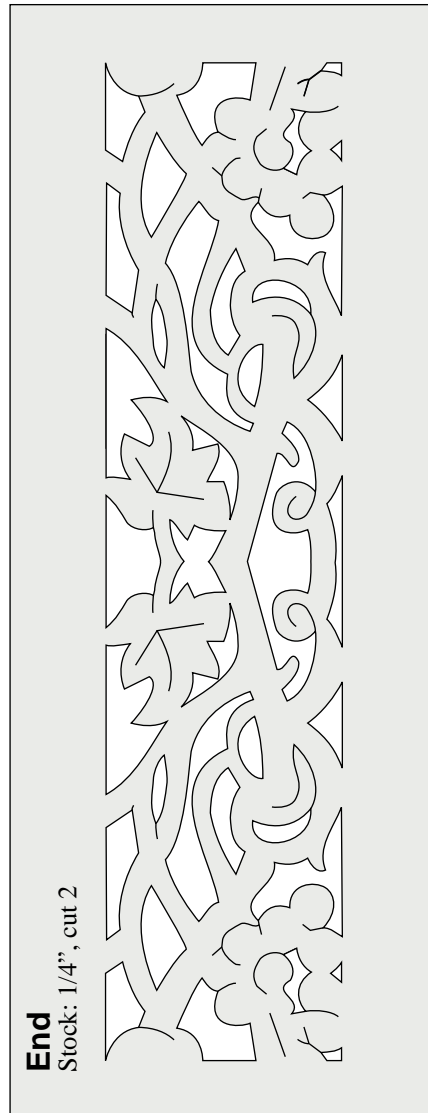
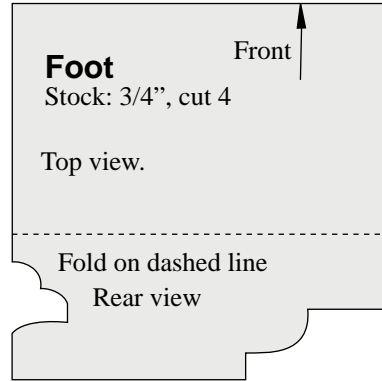
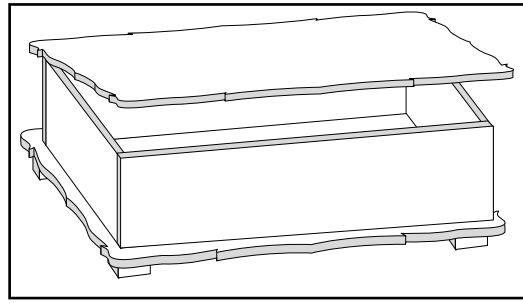
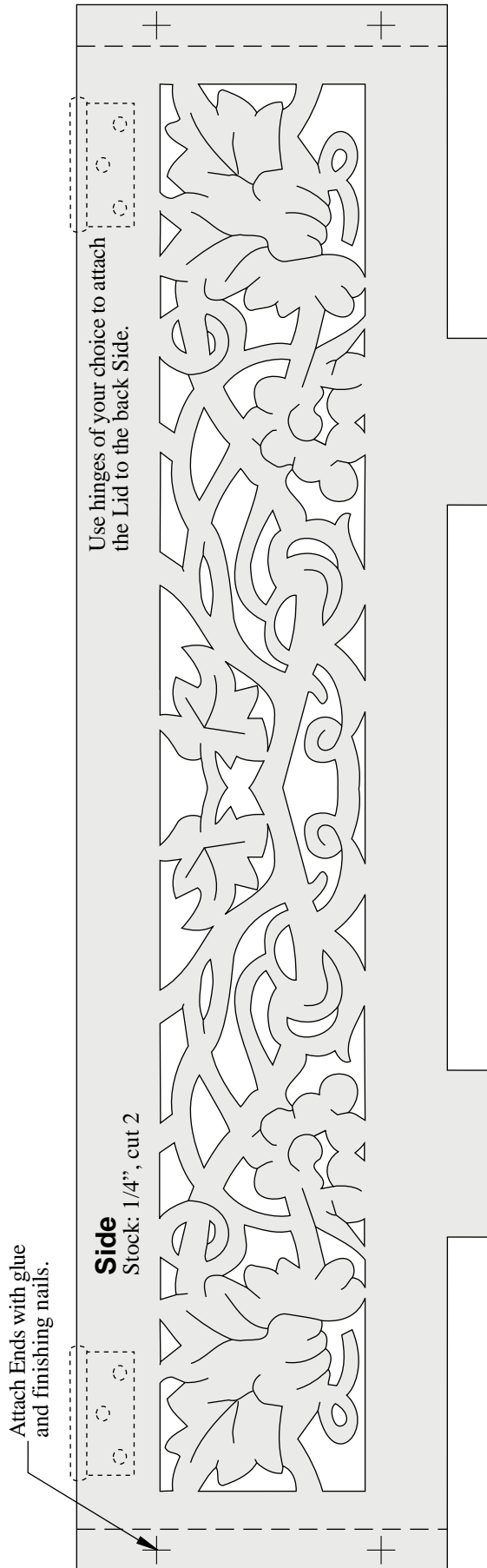

Lid

Stock: 1/4"

Use hinges of your choice to attach the Lid to the back Side.

Side

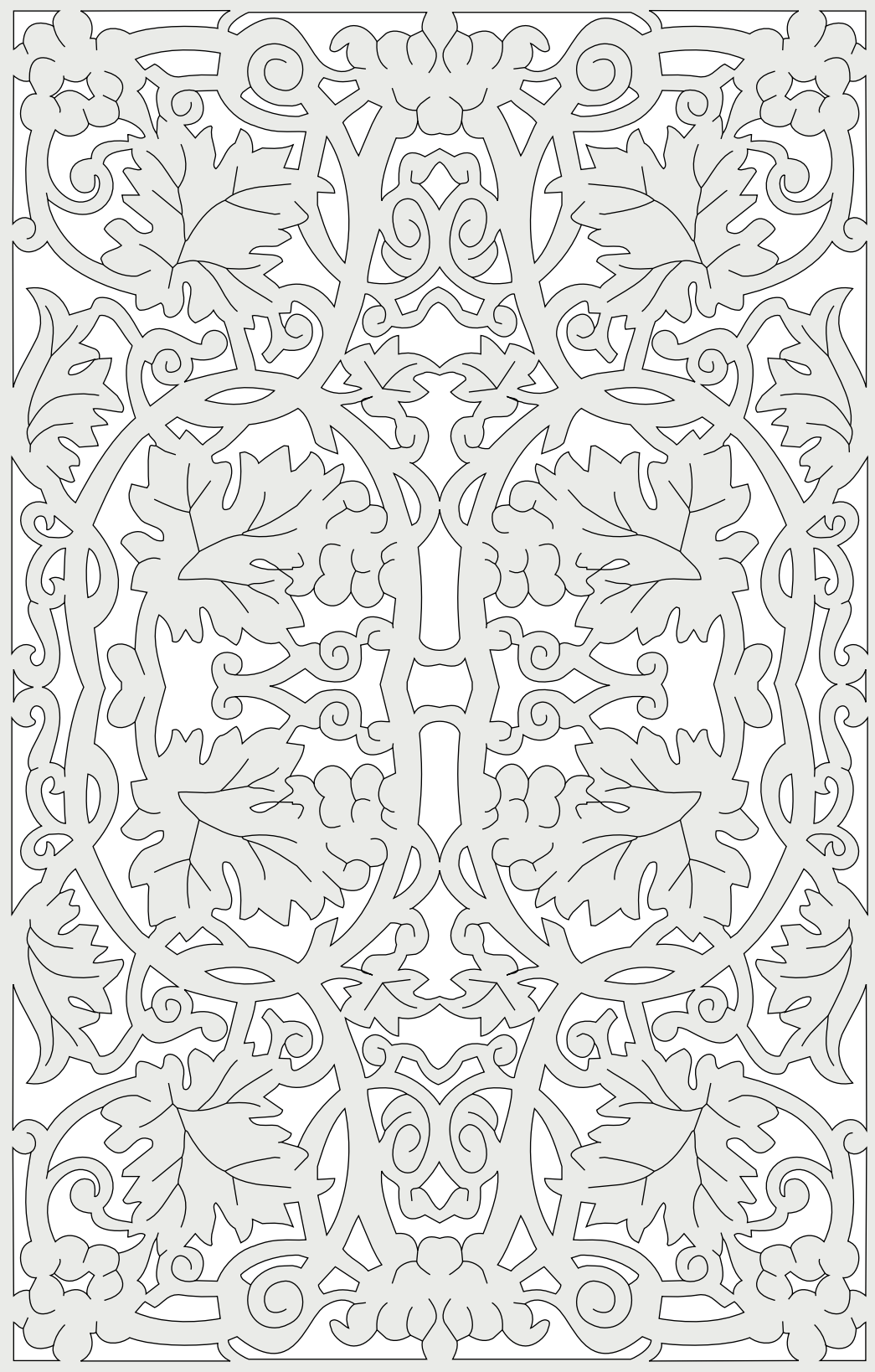

End

End

Side

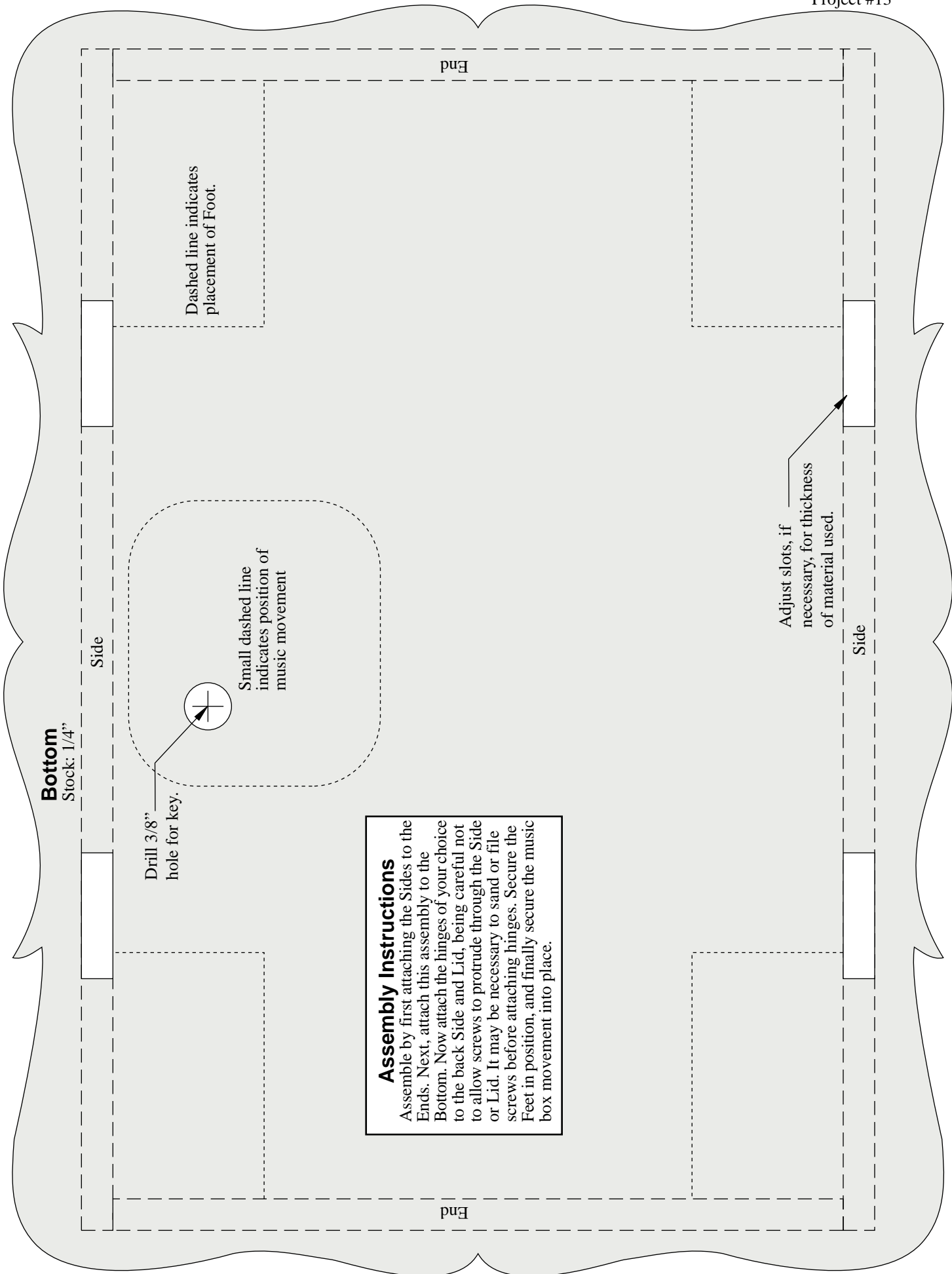

Bottom
Stock: 1/4"

Side

Drill 3/8"
hole for key.

Small dashed line
indicates position of
music movement

Dashed line indicates
placement of Foot.

End

End

Assembly Instructions

Assemble by first attaching the Sides to the Ends. Next, attach this assembly to the Bottom. Now attach the hinges of your choice to the back Side and Lid, being careful not to allow screws to protrude through the Side or Lid. It may be necessary to sand or file screws before attaching hinges. Secure the Feet in position, and finally secure the music box movement into place.

Adjust slots, if
necessary, for thickness
of material used.

Side

Project #14

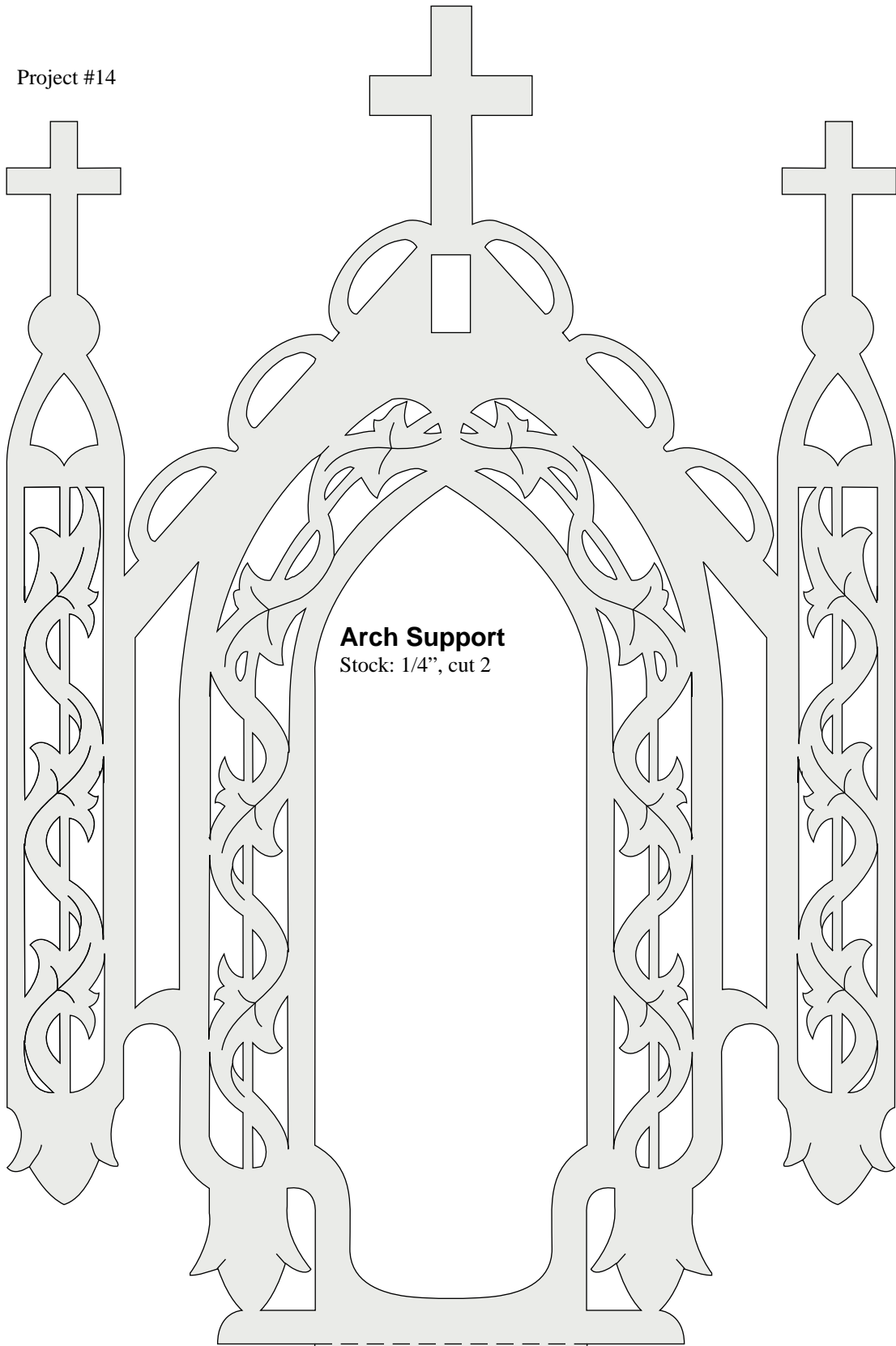

Arch Support
Stock: 1/4", cut 2

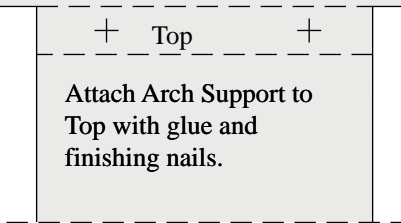

Attach Arch Support to
Top with glue and
finishing nails.

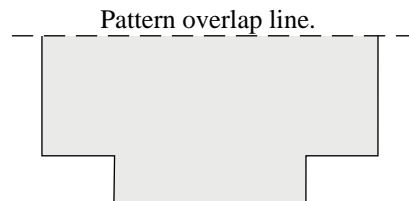

Pattern overlap line.

Pattern overlap line.

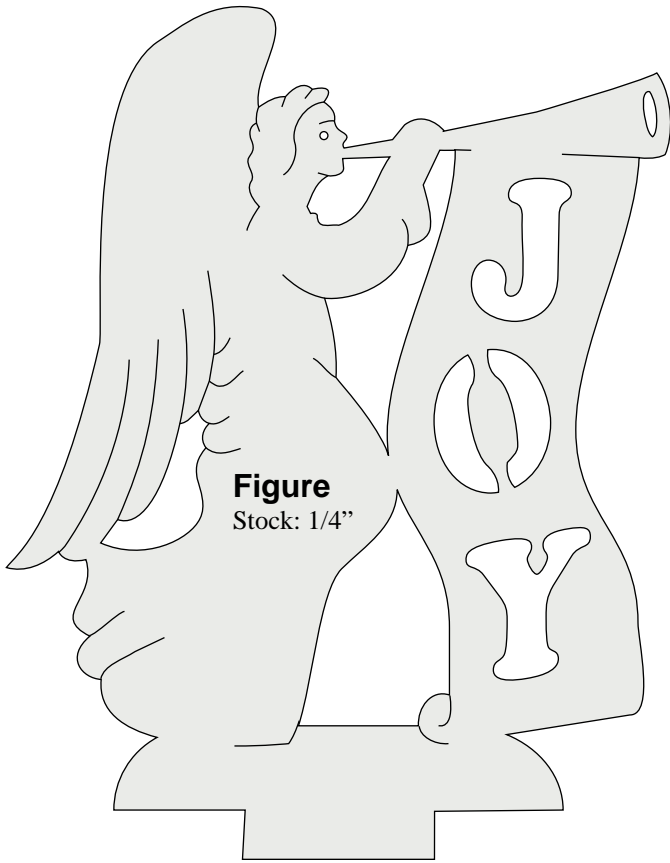
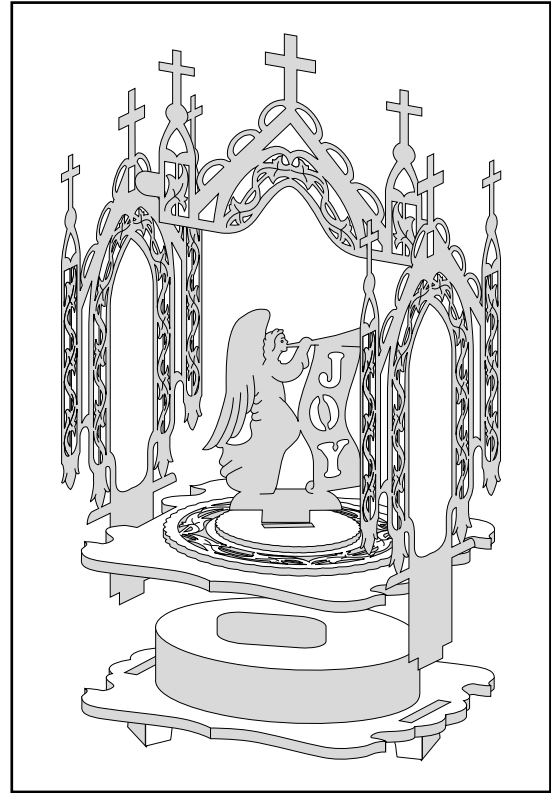
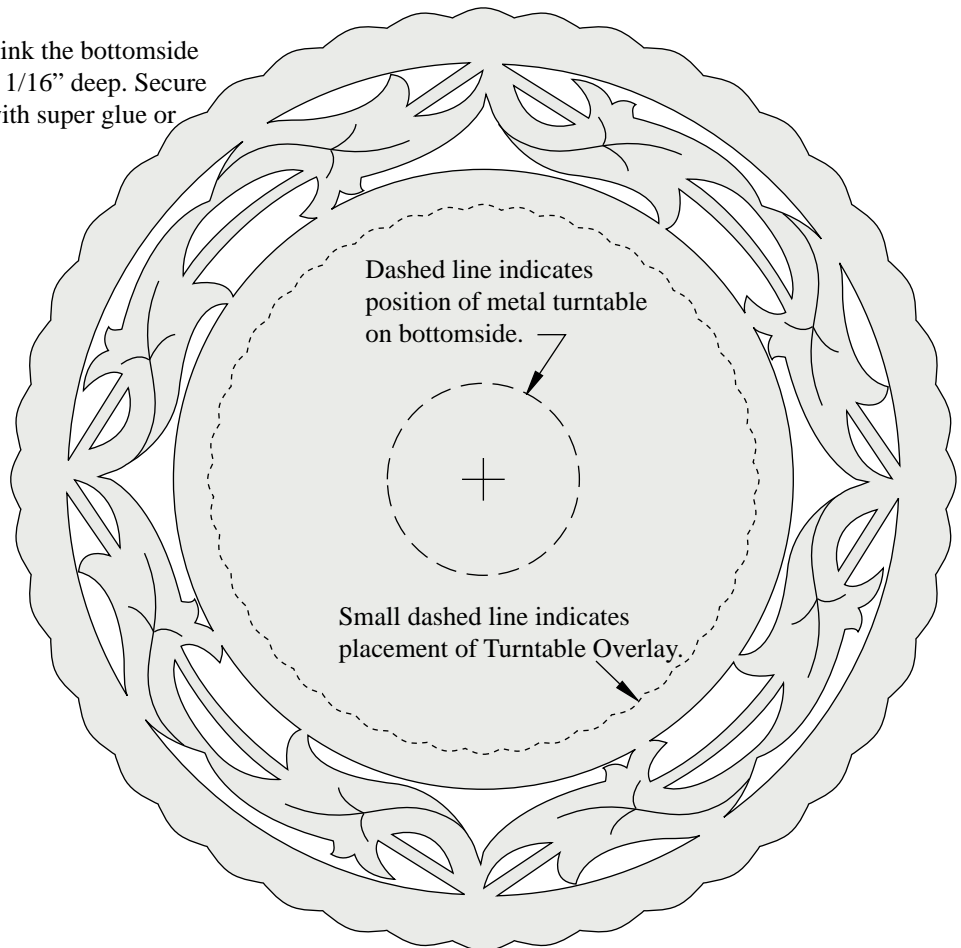

Figure
Stock: 1/4"



Turntable

Stock: 1/4", countersink the bottomside with a 1" forstner bit 1/16" deep. Secure the metal turntable with super glue or silicone.



Project #14

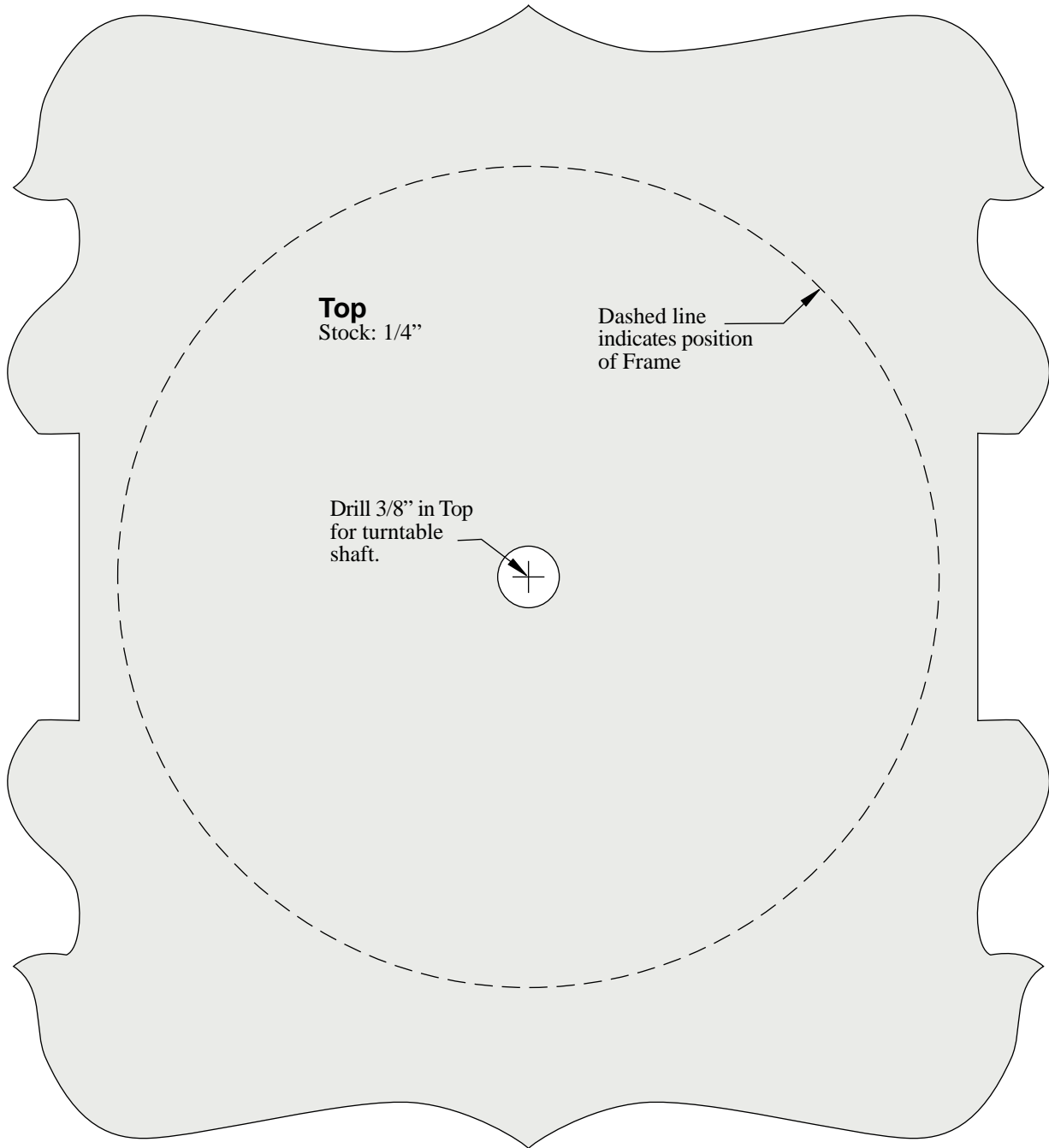
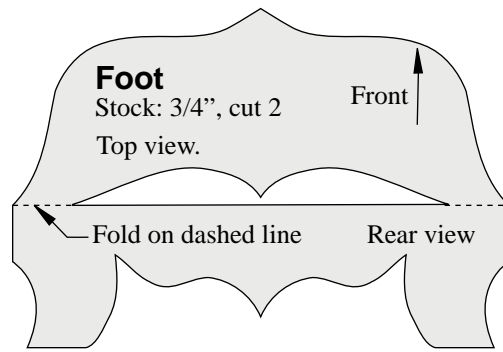

Turntable Overlay

Stock: 1/4"

Project #14



Adjust slot, if necessary, for thickness of material used.

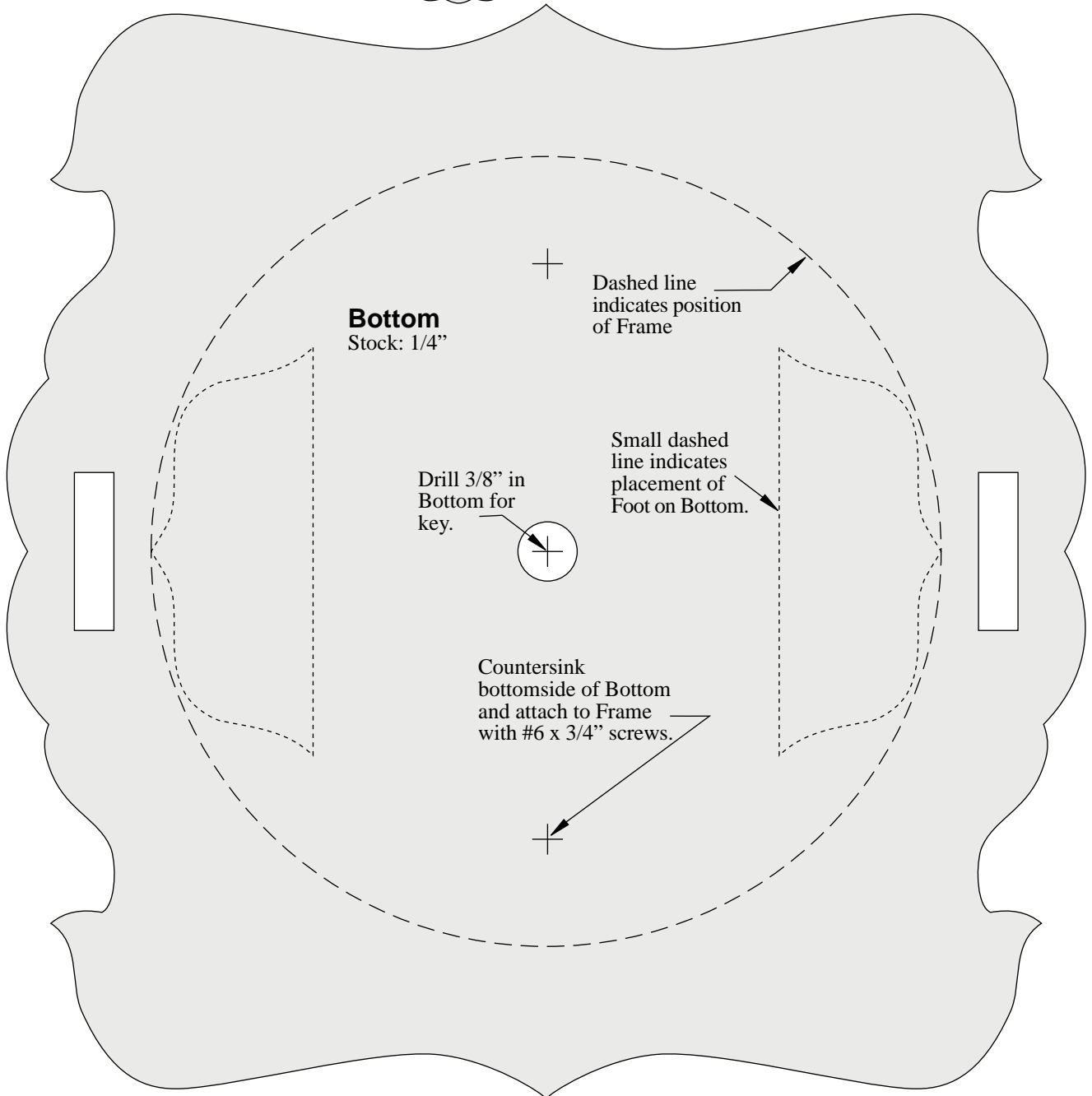

Project #14

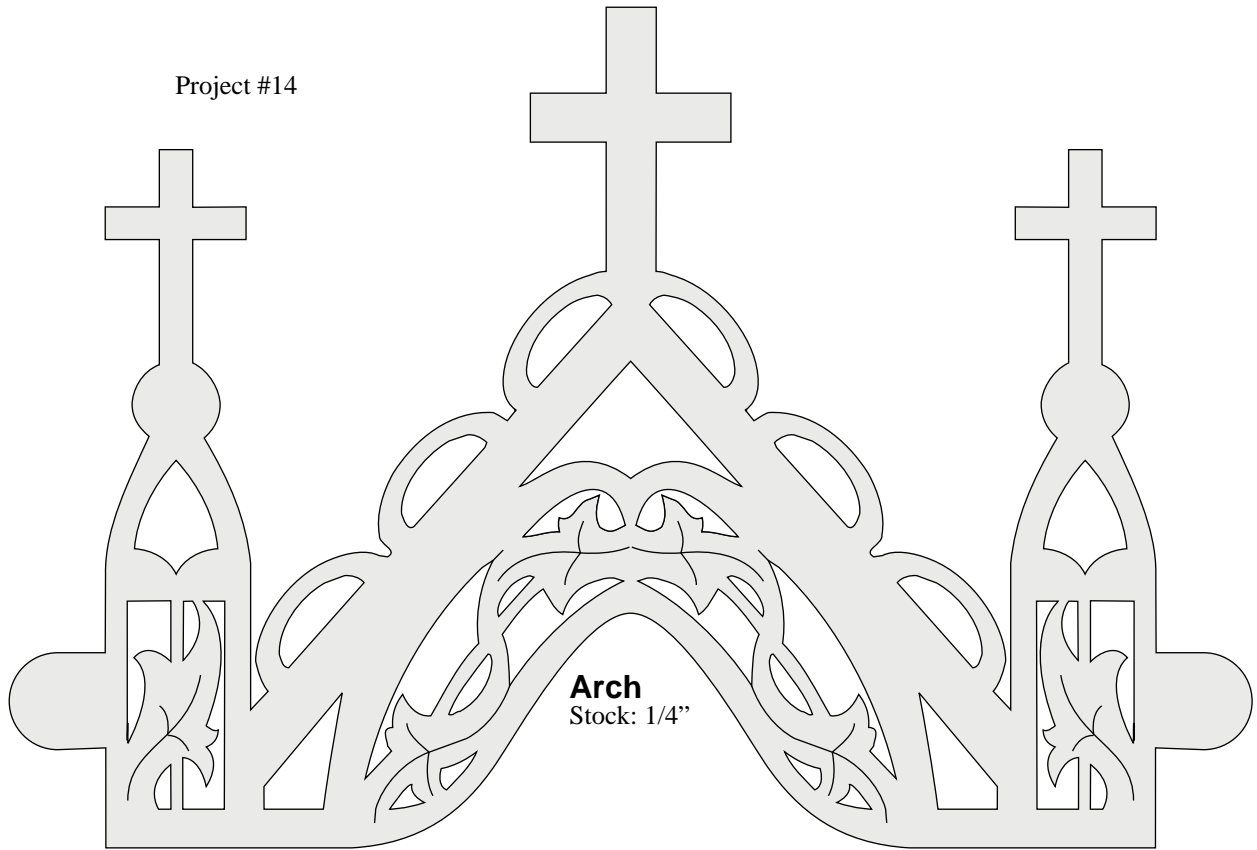

Frame

Stock: 1 1/2"

Circle indicates
position of key and
turntable shafts.



Cut out for music box

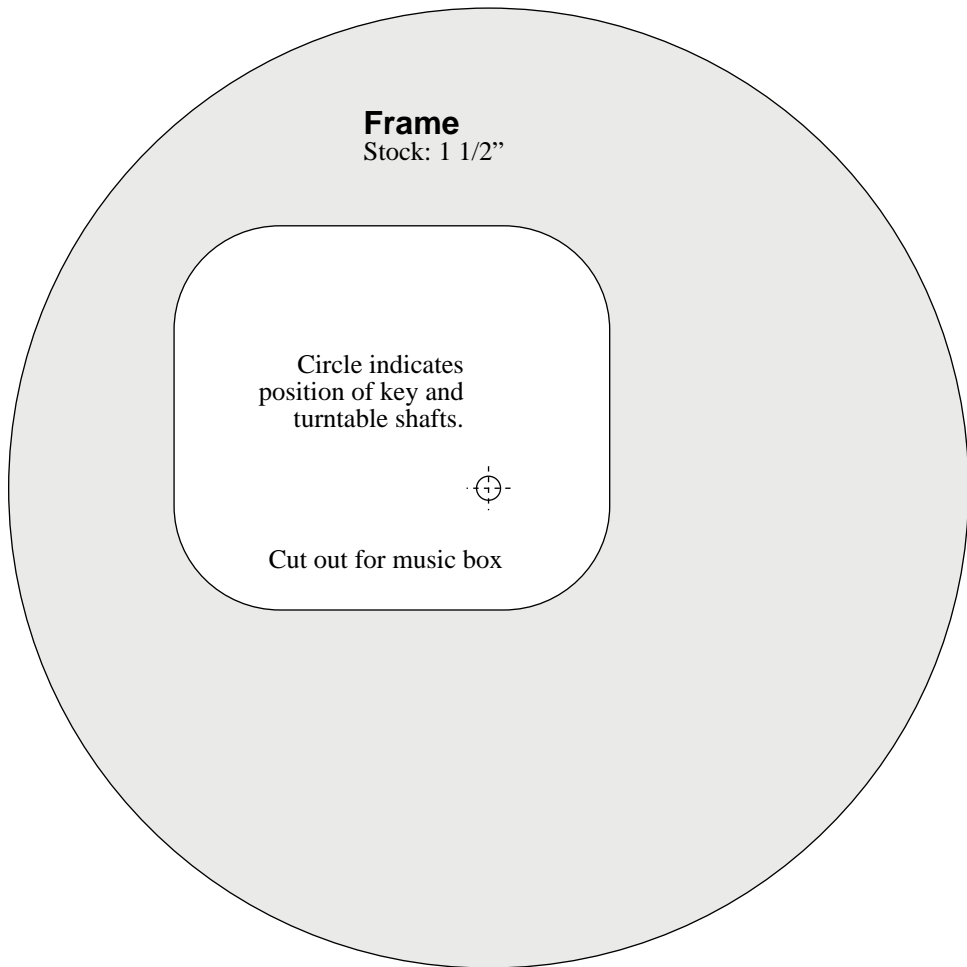

Frame
Stock: 1 1/2"

Assembly Instructions
To Assemble, attach Legs to Apron Support with glue. Next, attach the Aprons. Then clamp this assembly to the bottomsink of the Bottom and countersink to attach the assembly to the Frame with #6 x 1" F.H. screws.

Circle indicates position of key and turntable shafts.



Cut out for music box

Project #15

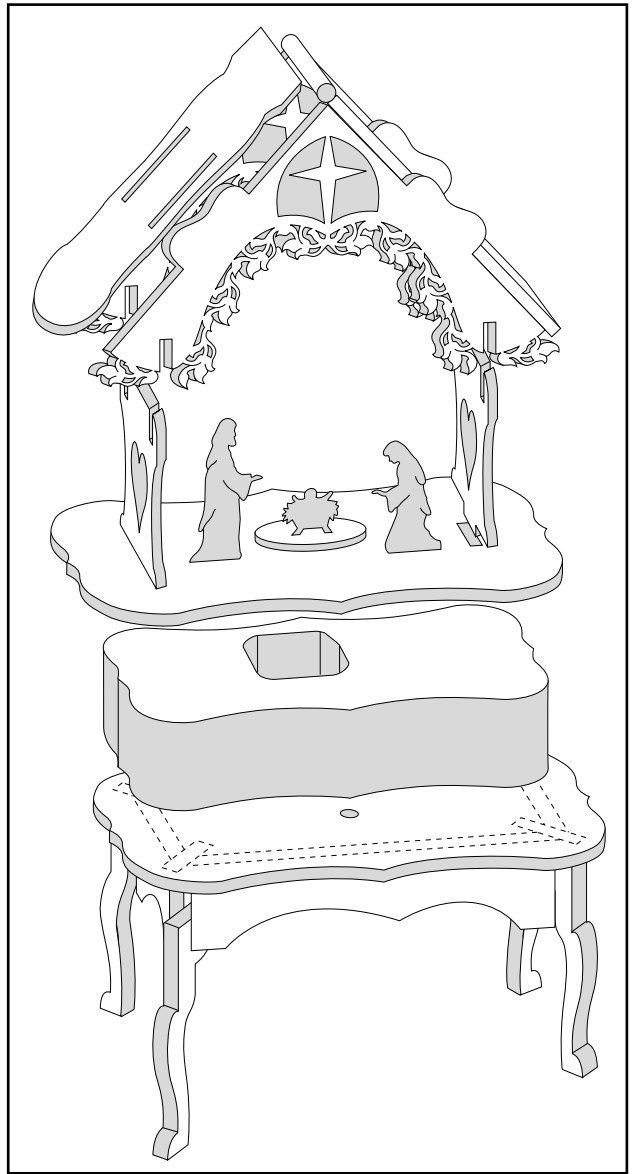

Project #15

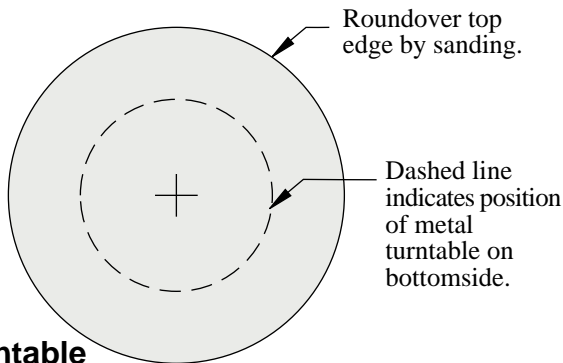
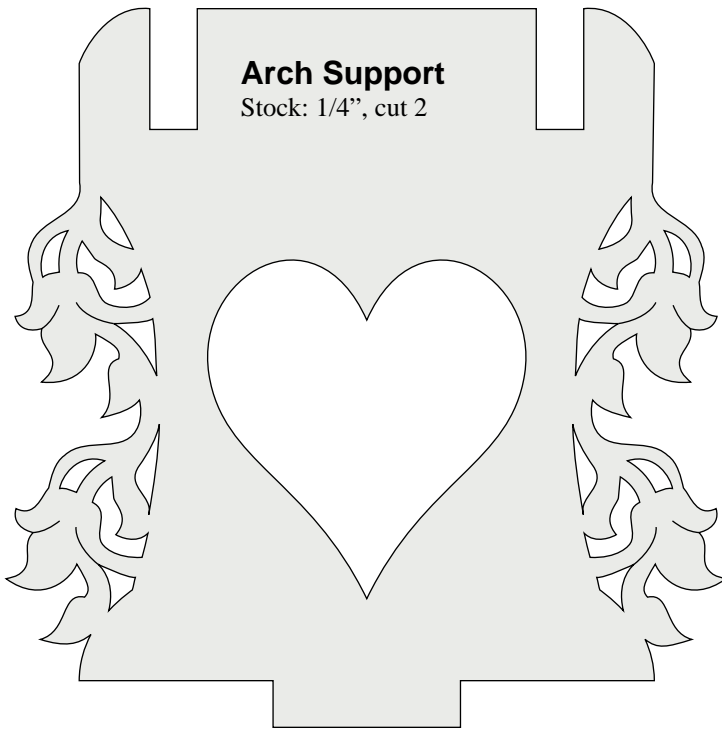

Turntable

Stock: 1/4". Countersink the bottomside with a 1" forstner bit 1/16" deep. Secure the metal turntable with super glue or silicone.

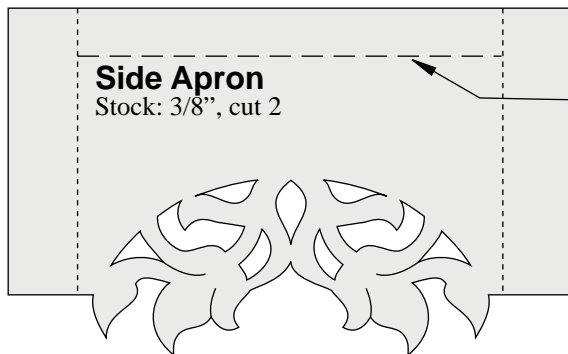
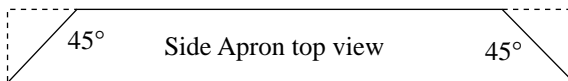

Dashed line indicates placement of Apron. Attach Apron to Apron Support with glue.

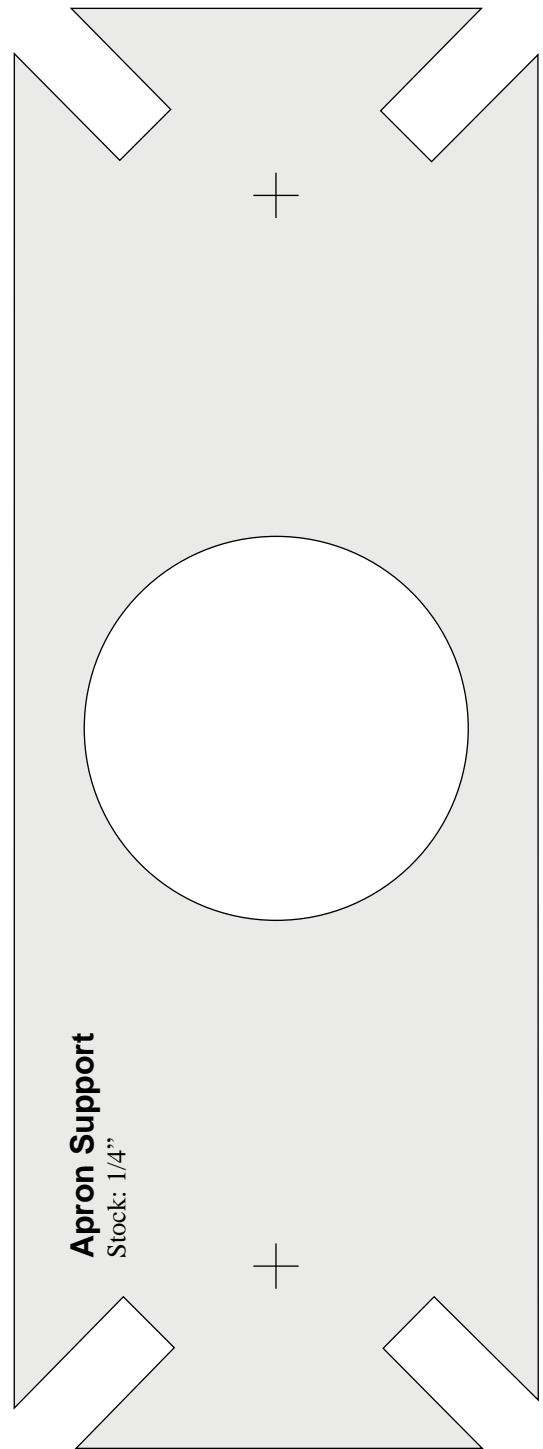

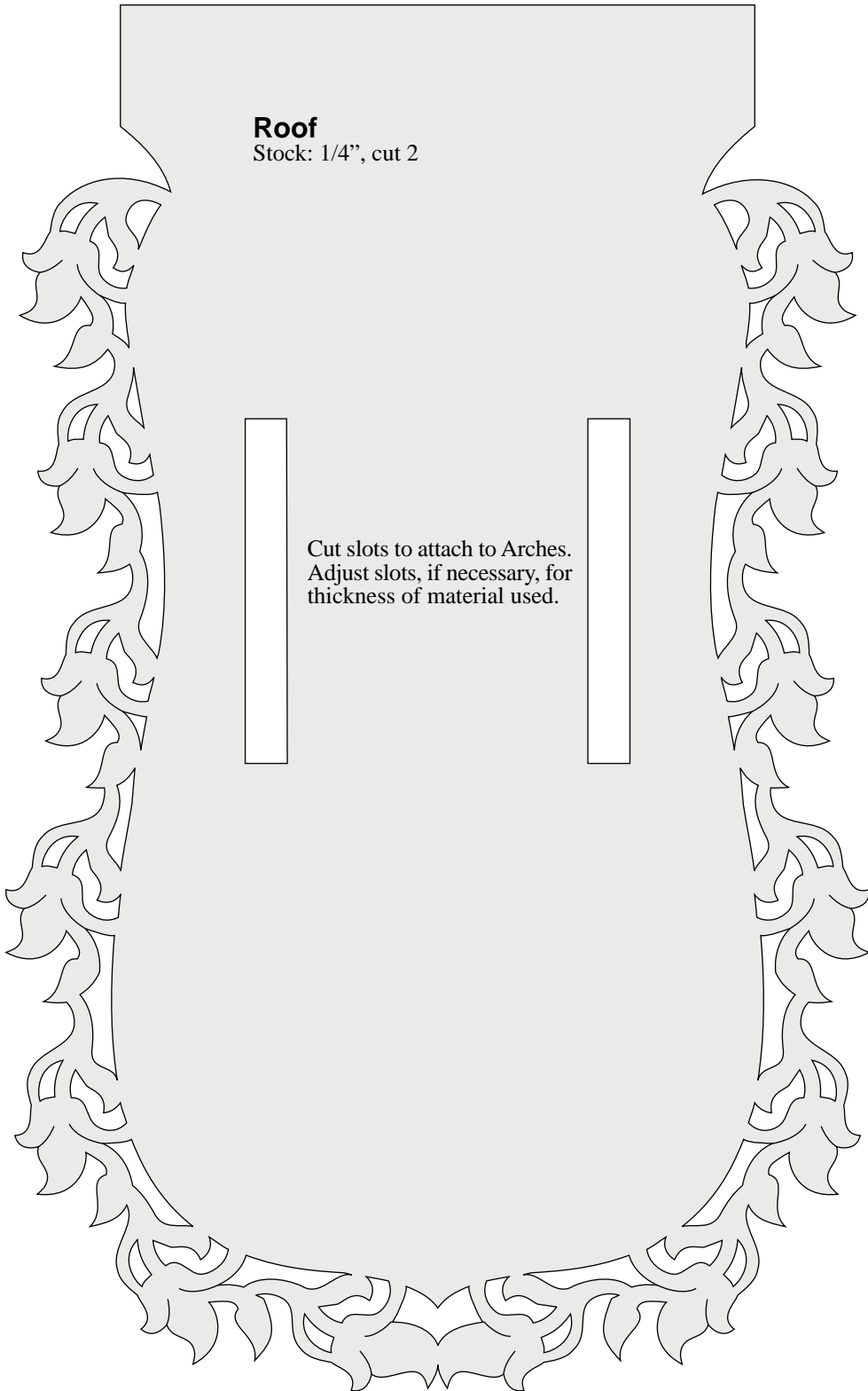
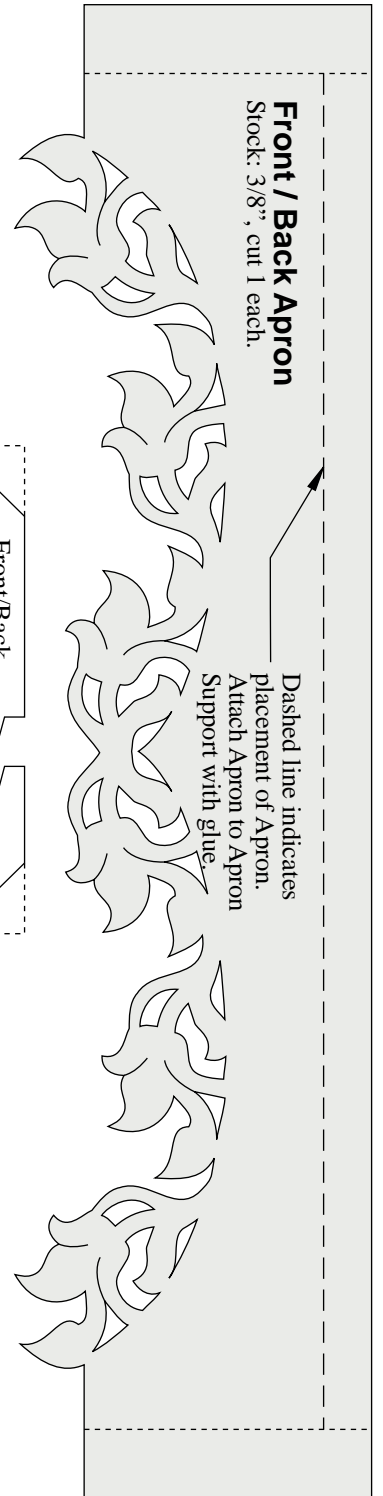

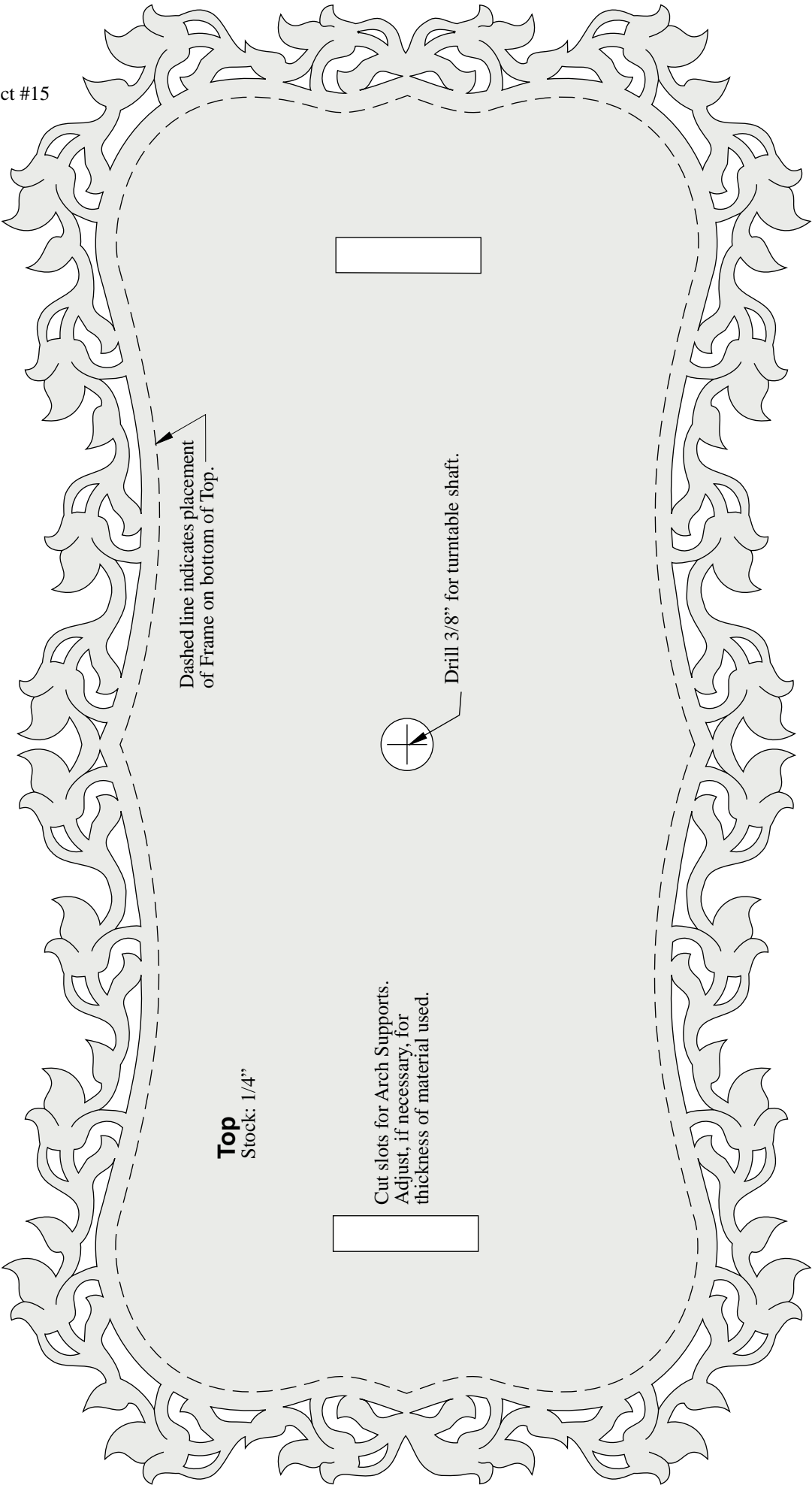

Dashed line indicates placement of Frame on bottom of Top.

Drill 3/8" for turntable shaft.

Cut slots for Arch Supports. Adjust, if necessary, for thickness of material used.

Top
Stock: 1/4"

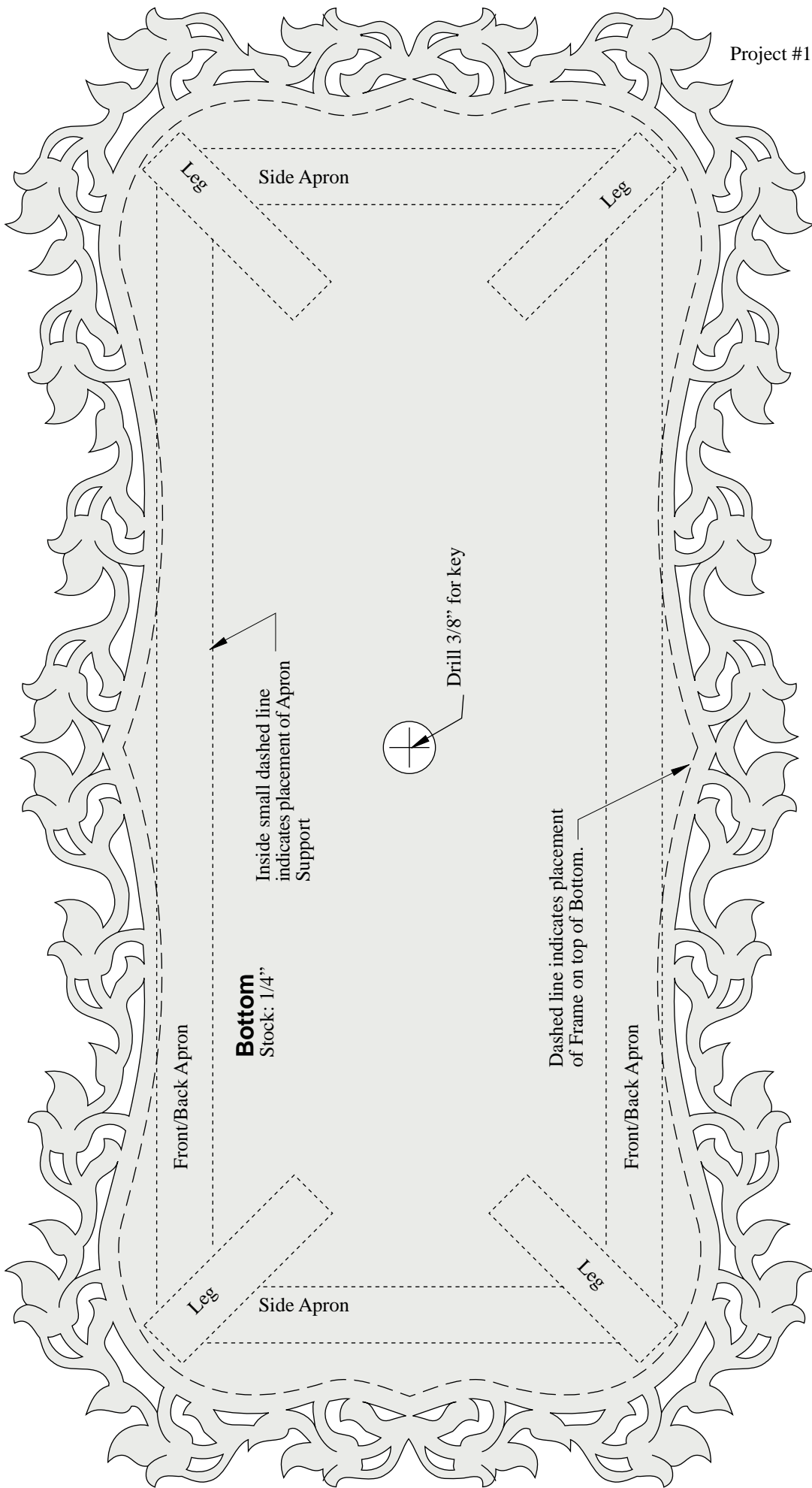

Project #15

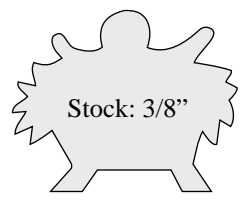

Fill gap with 3/8" dowel.

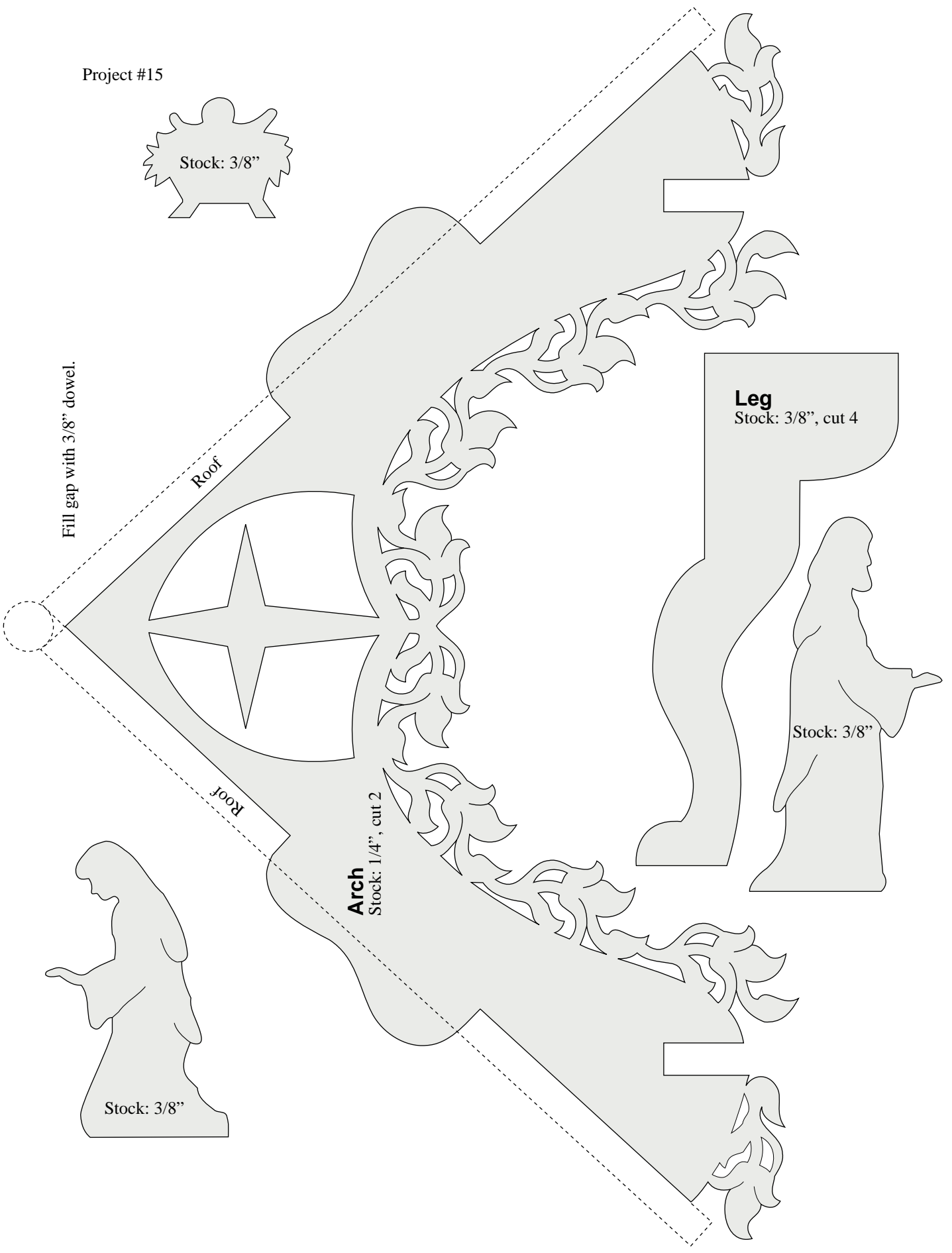

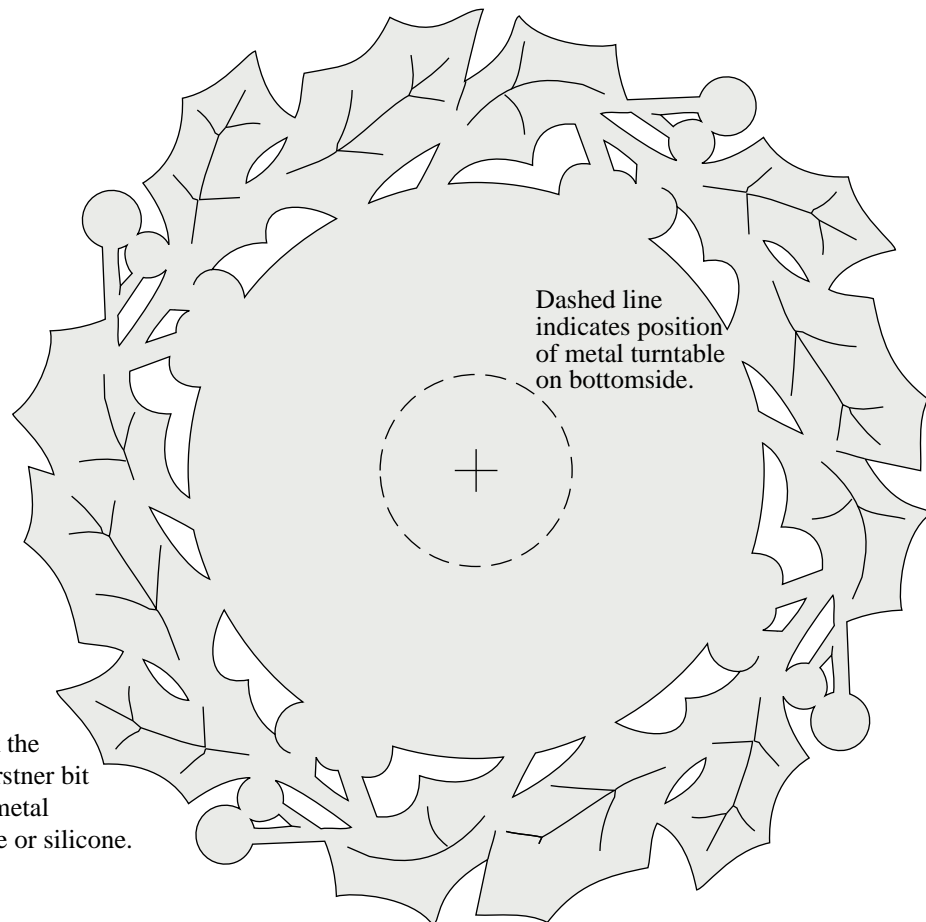
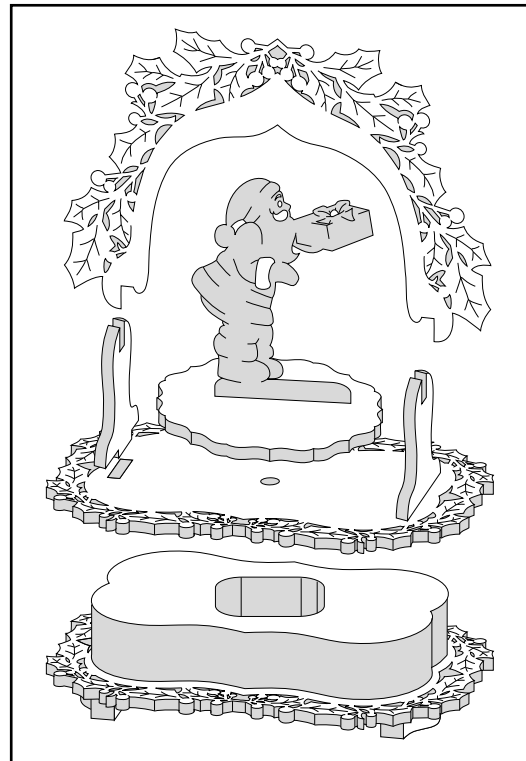
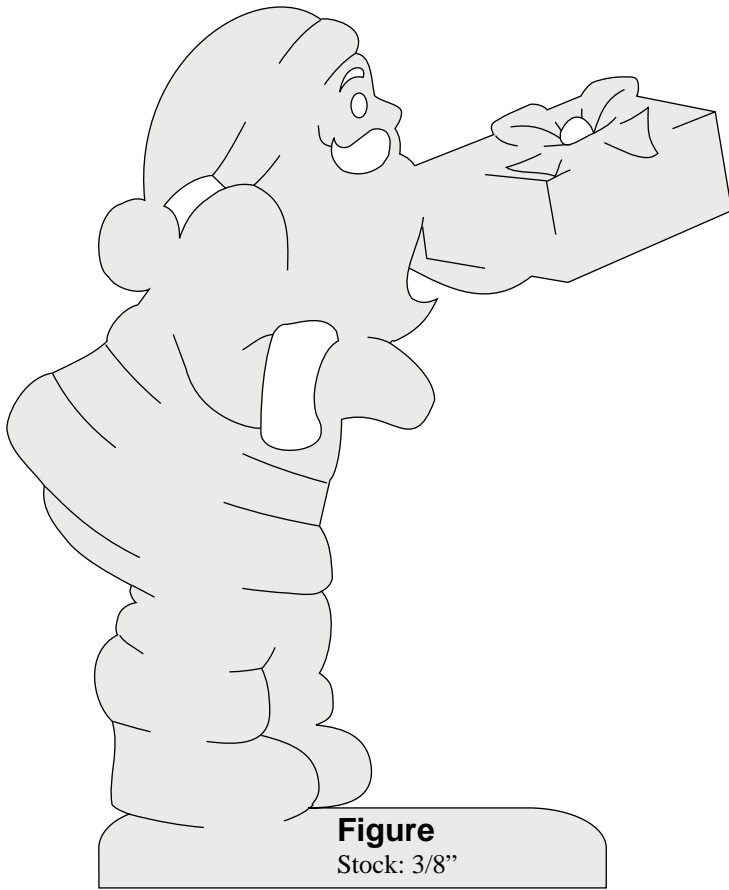

Turntable

Stock: 1/4", countersink the bottomside with a 1" forstner bit 1/16" deep. Secure the metal turntable with super glue or silicone.

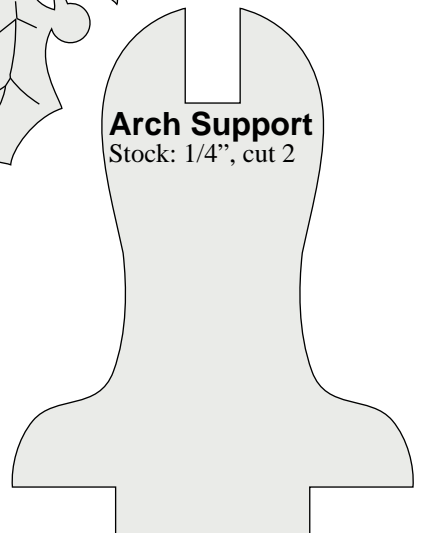
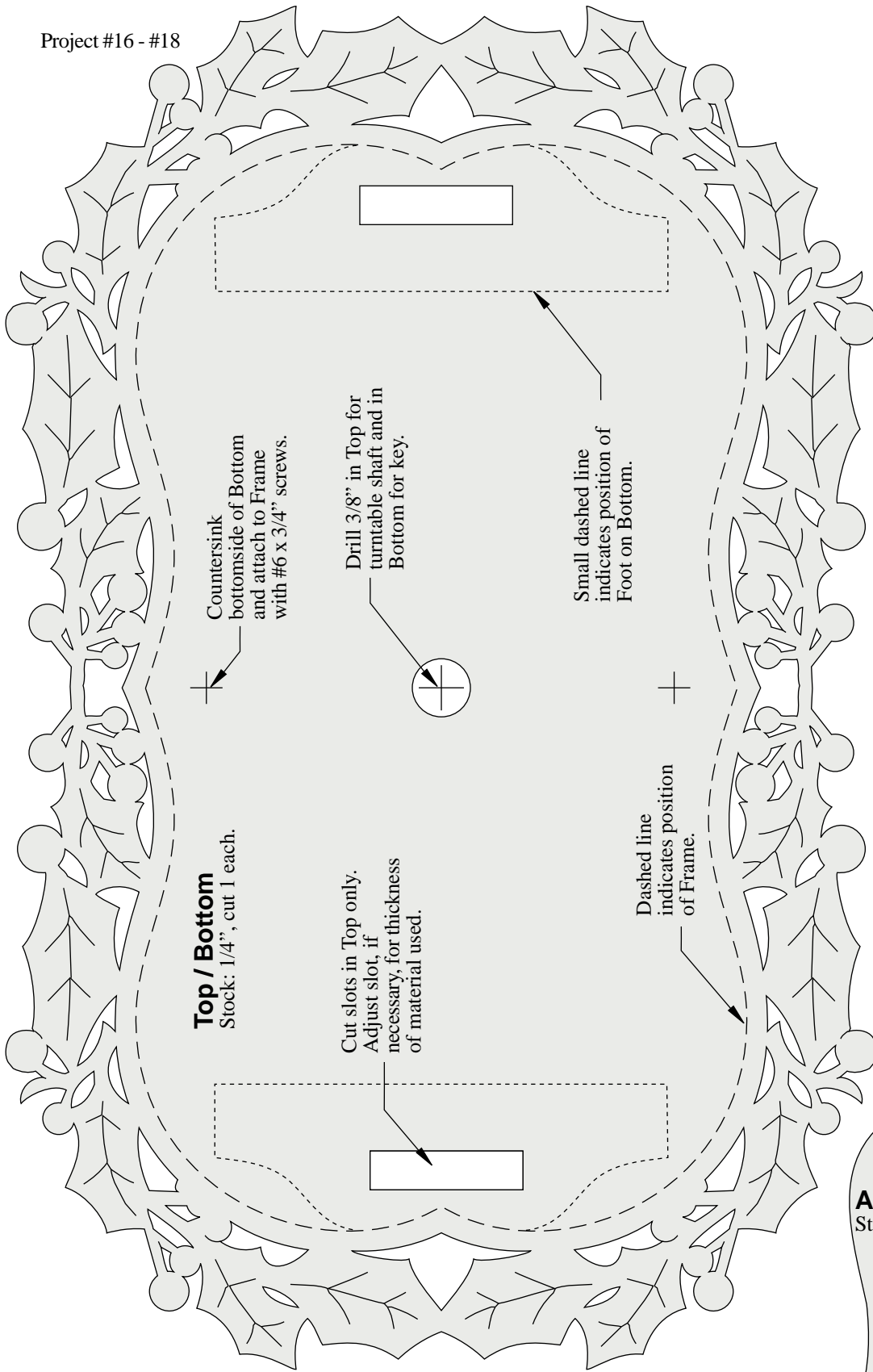

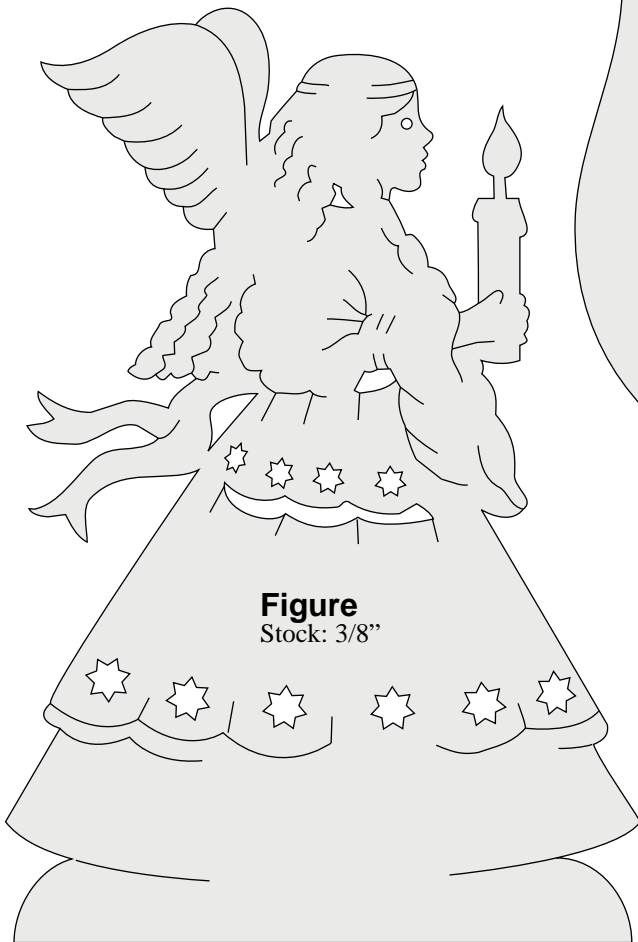
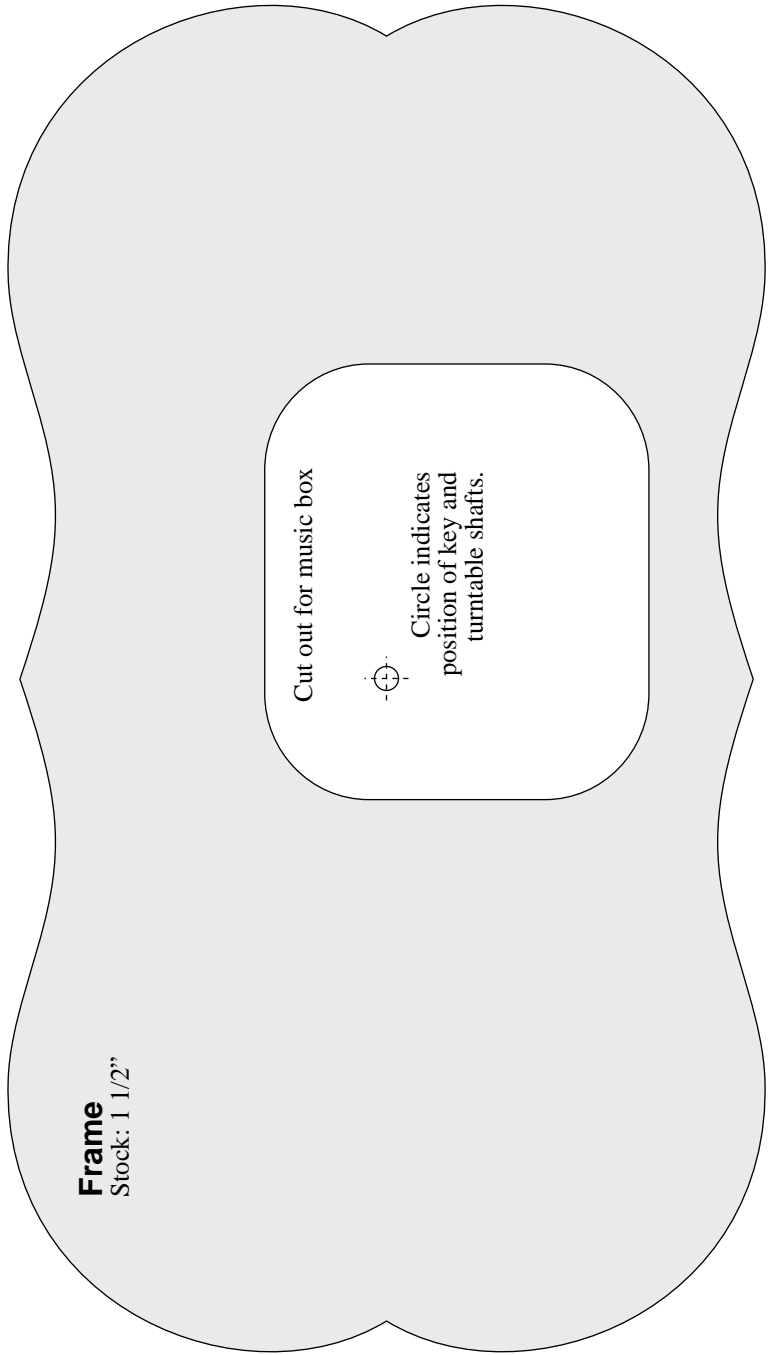
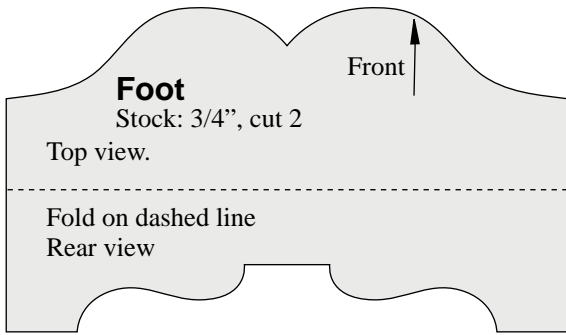

Project #16 - #18

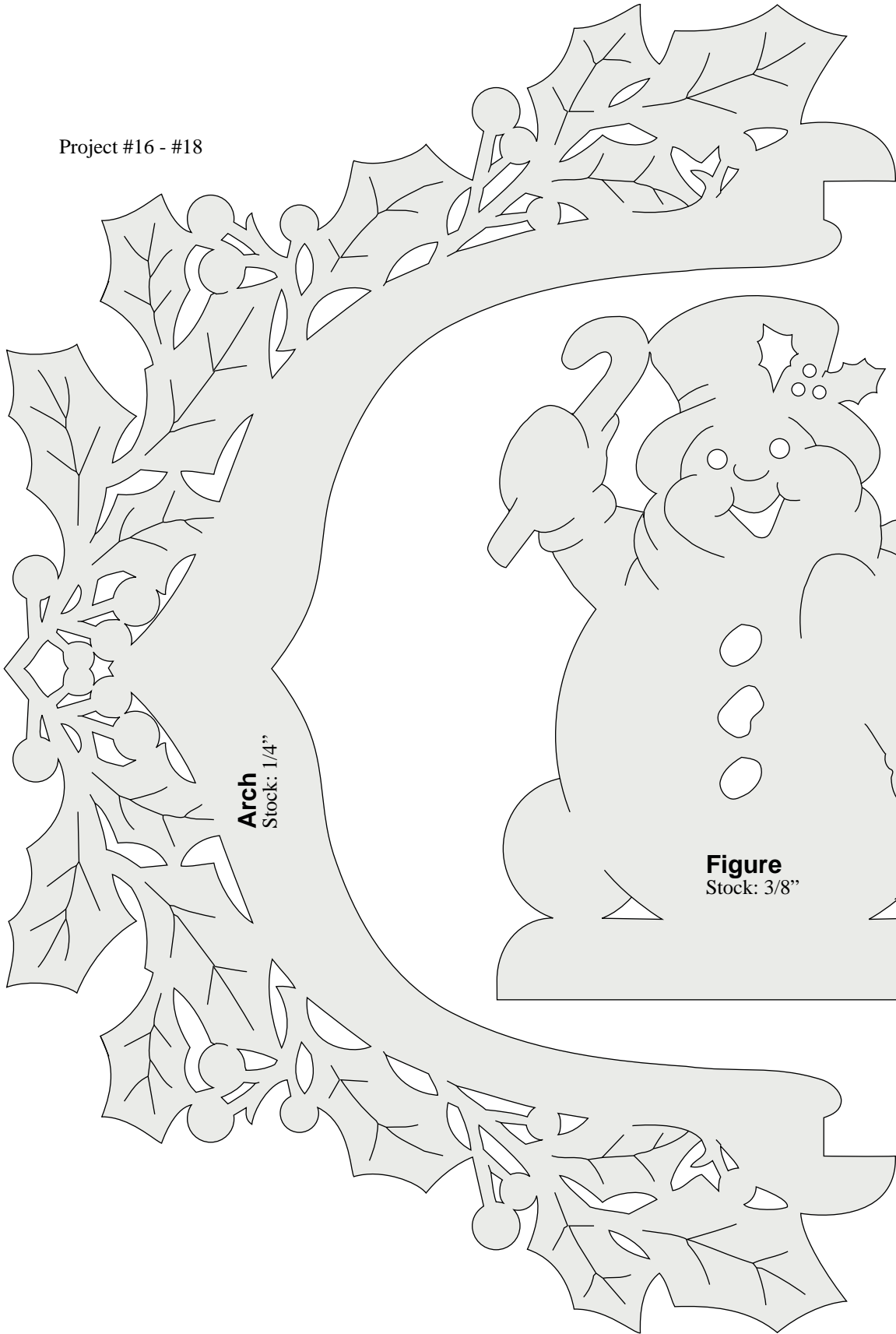

Arch
Stock: 1/4"

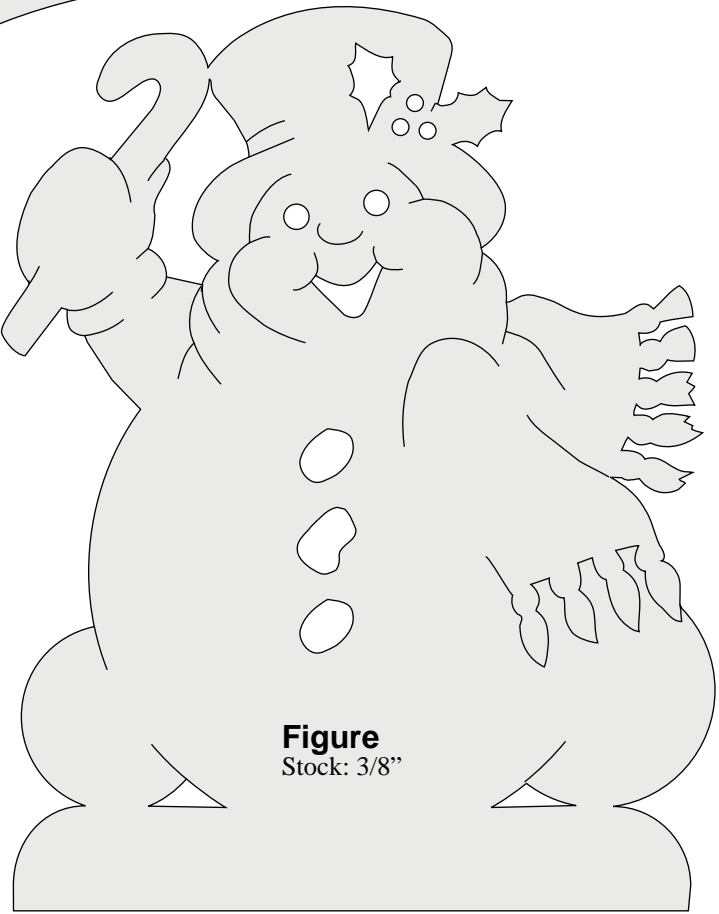
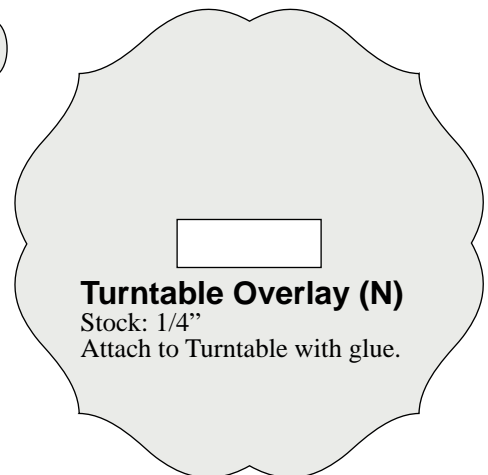
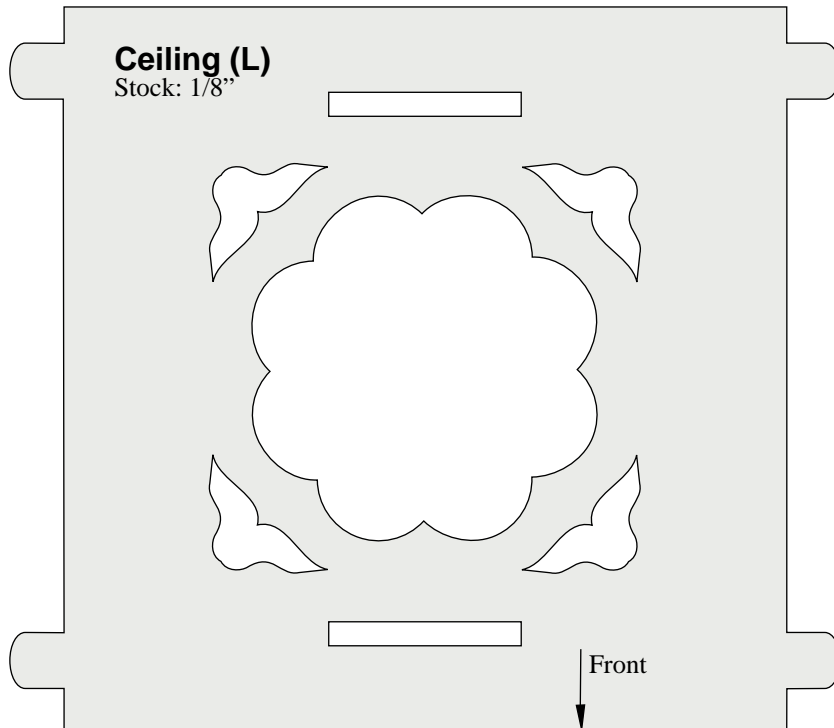
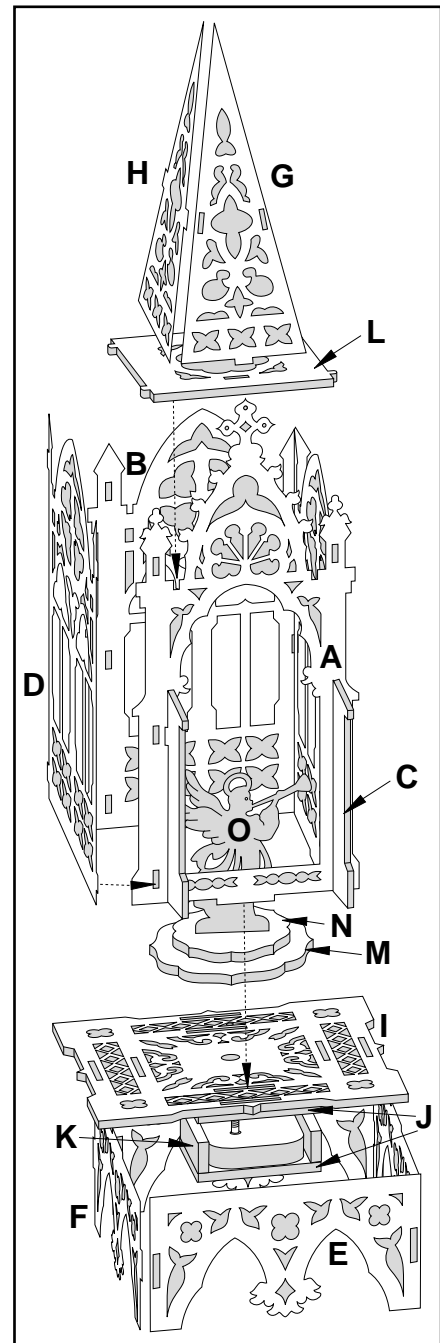
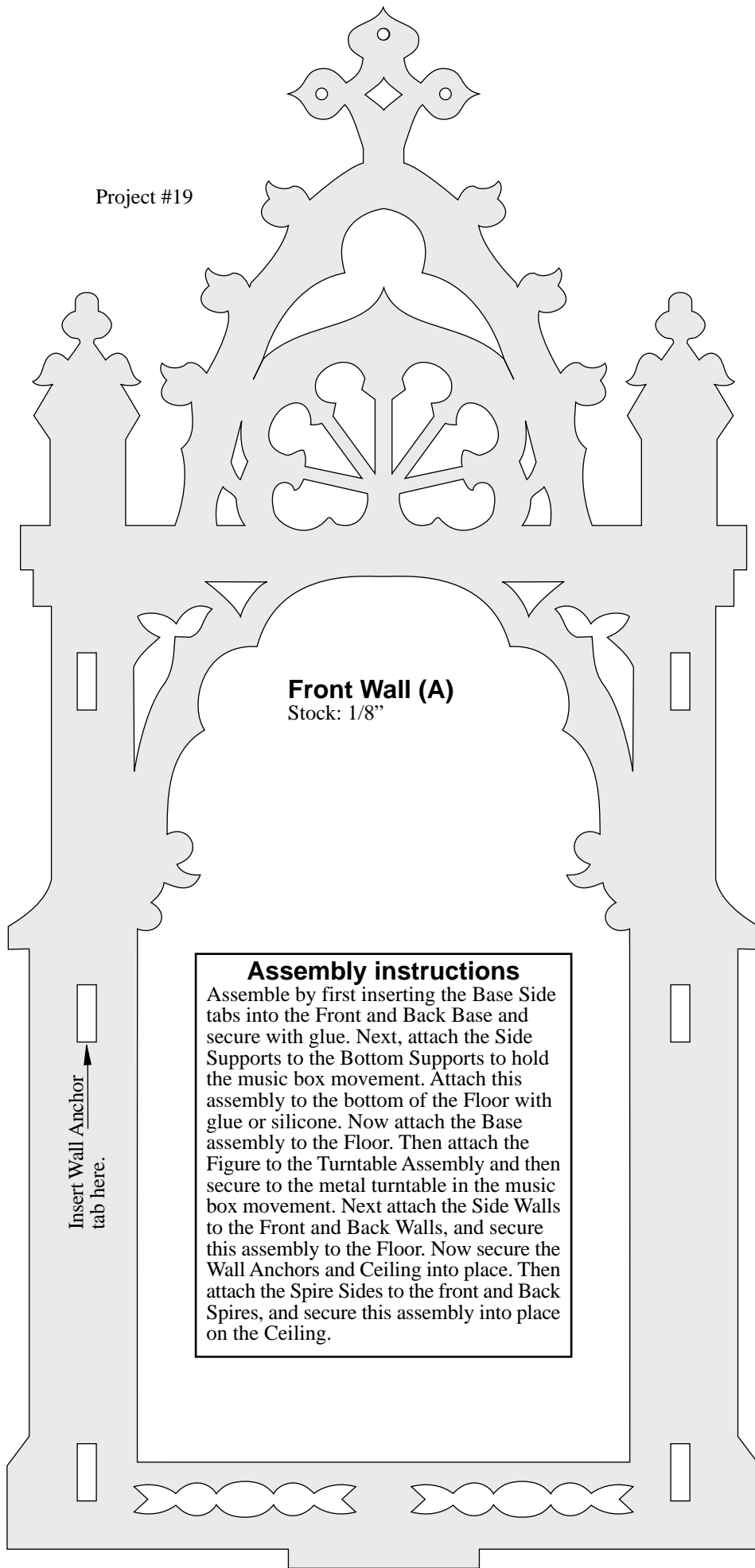

Figure
Stock: 3/8"

Cathedral Music Box		
Description	item	Qty
Front Wall	A	1
Back Wall	B	1
Wall Anchor	C	4
Side Wall	D	2
Front & Back Base	E	1 each
Base Side	F	2
Front & Back Spire	G	1 each
Spire Side	H	2
Floor	I	1
Bottom Support	J	2
Side Support	K	2
Ceiling	L	1
Turntable	M	1
Turntable Overlay	N	1
Figure	O	1



Project #19



Front Wall (A)
Stock: 1/8"

Wall Anchor (C)
Stock: 1/8", cut 4

Assembly instructions

Assemble by first inserting the Base Side tabs into the Front and Back Base and secure with glue. Next, attach the Side Supports to the Bottom Supports to hold the music box movement. Attach this assembly to the bottom of the Floor with glue or silicone. Now attach the Base assembly to the Floor. Then attach the Figure to the Turntable Assembly and then secure to the metal turntable in the music box movement. Next attach the Side Walls to the Front and Back Walls, and secure this assembly to the Floor. Now secure the Wall Anchors and Ceiling into place. Then attach the Spire Sides to the front and Back Spires, and secure this assembly into place on the Ceiling.

Insert Wall Anchor
tab here.

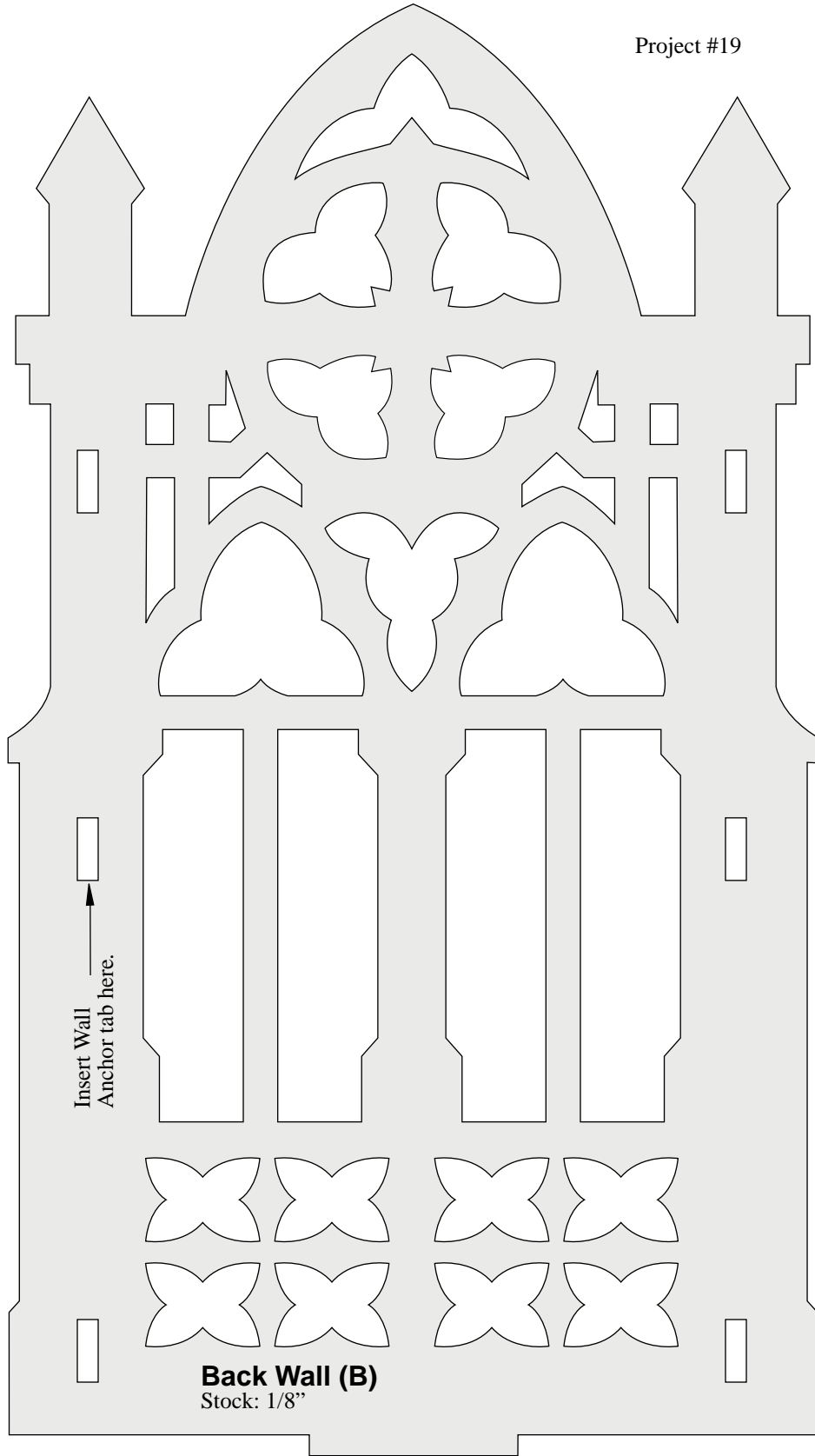

Project #19

Ceiling tab fits here

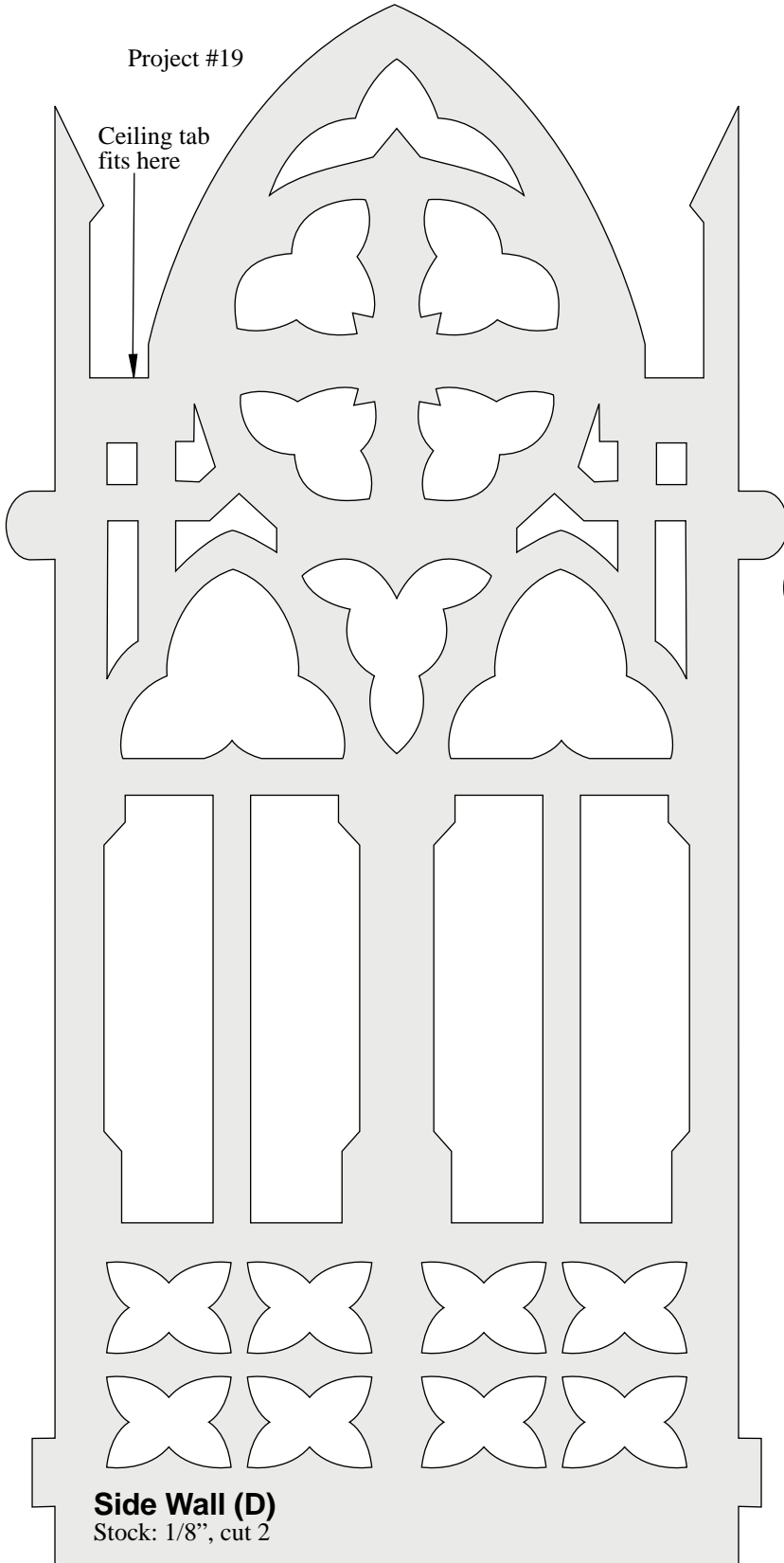

Side Wall (D)
Stock: 1/8", cut 2

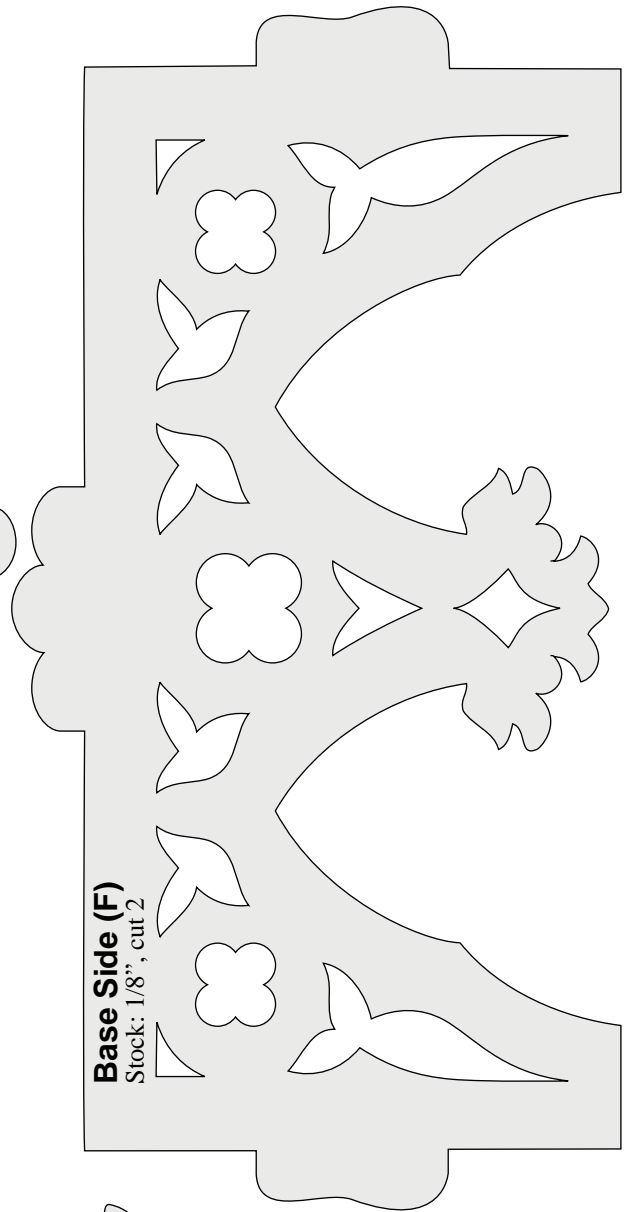

Base Side (F)
Stock: 1/8", cut 2

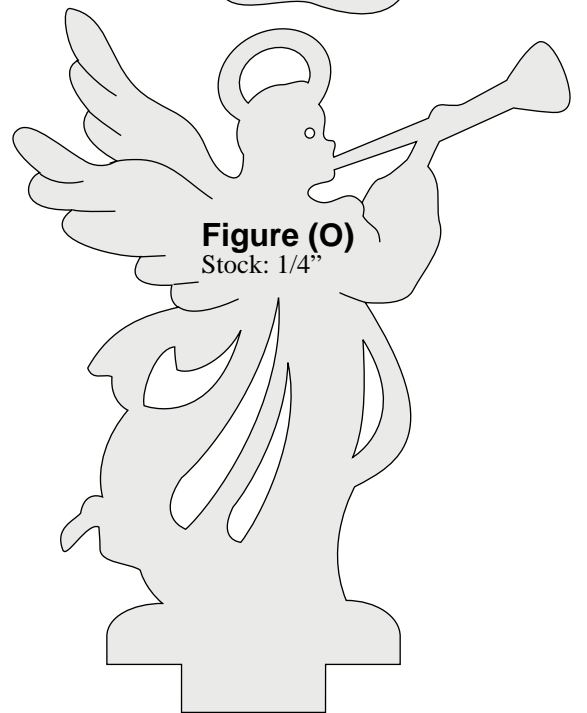
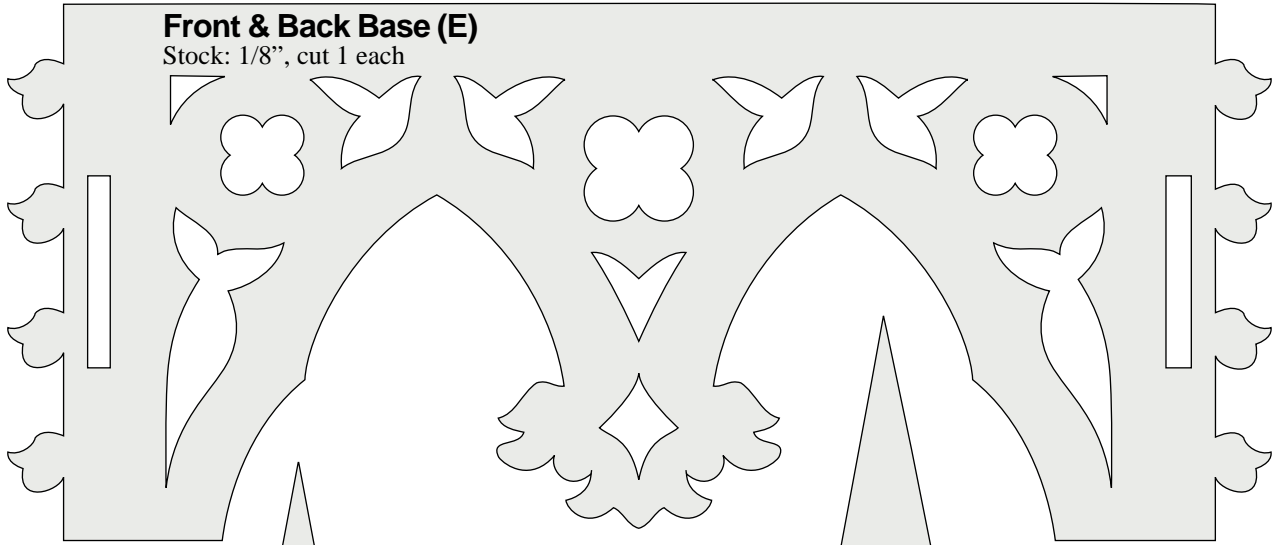

Figure (O)
Stock: 1/4"

Front & Back Base (E)

Stock: 1/8", cut 1 each



Front & Back Spire (G)

Stock: 1/8", cut 1 each

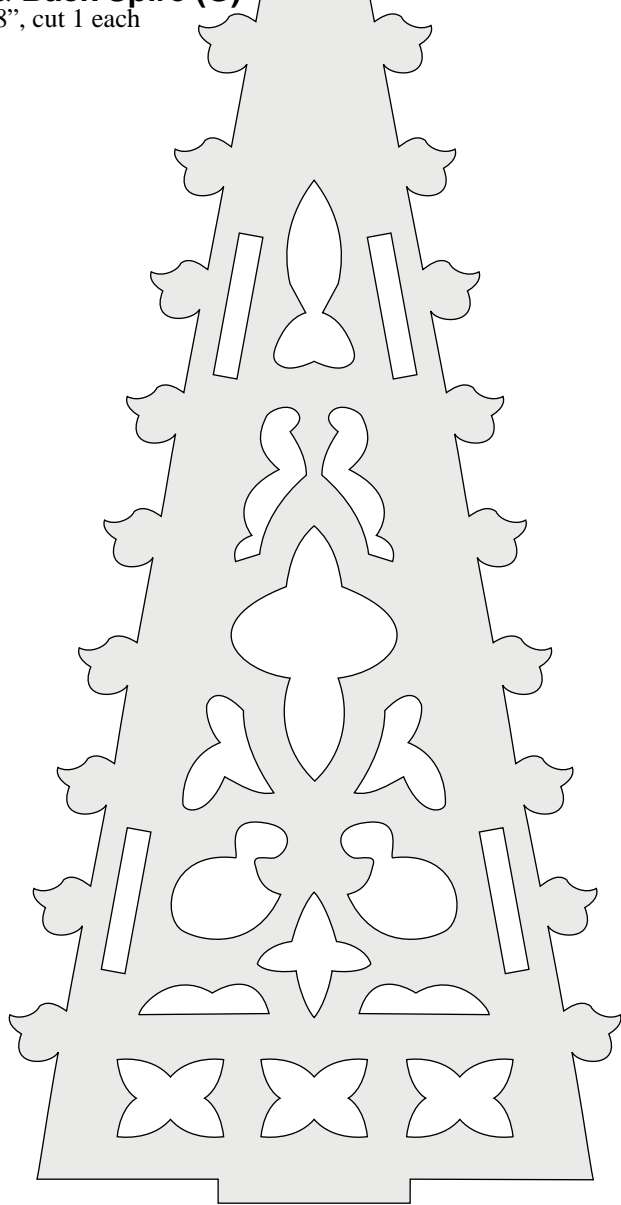

Spire Side (H)

Stock: 1/8", cut 2

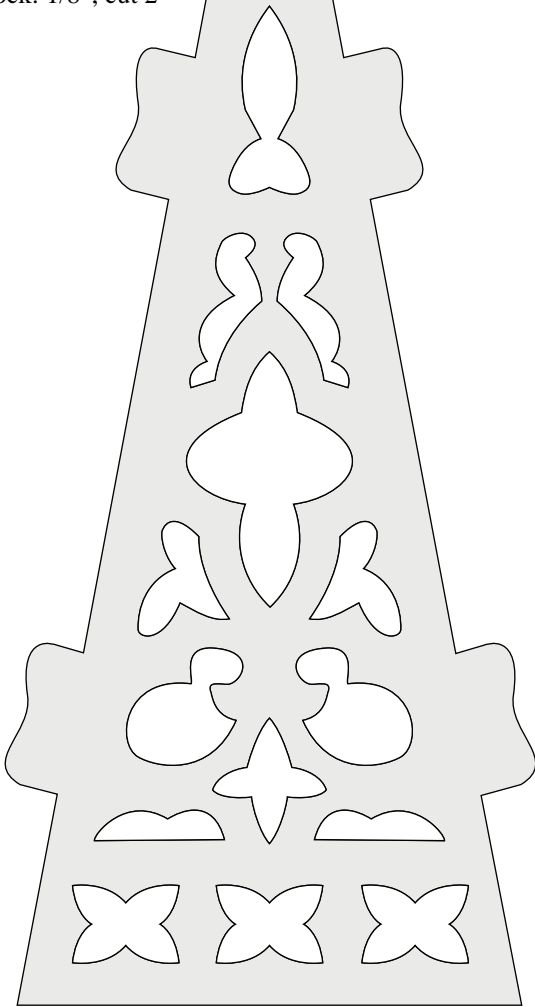

Floor (I)
Stock: 1/4"

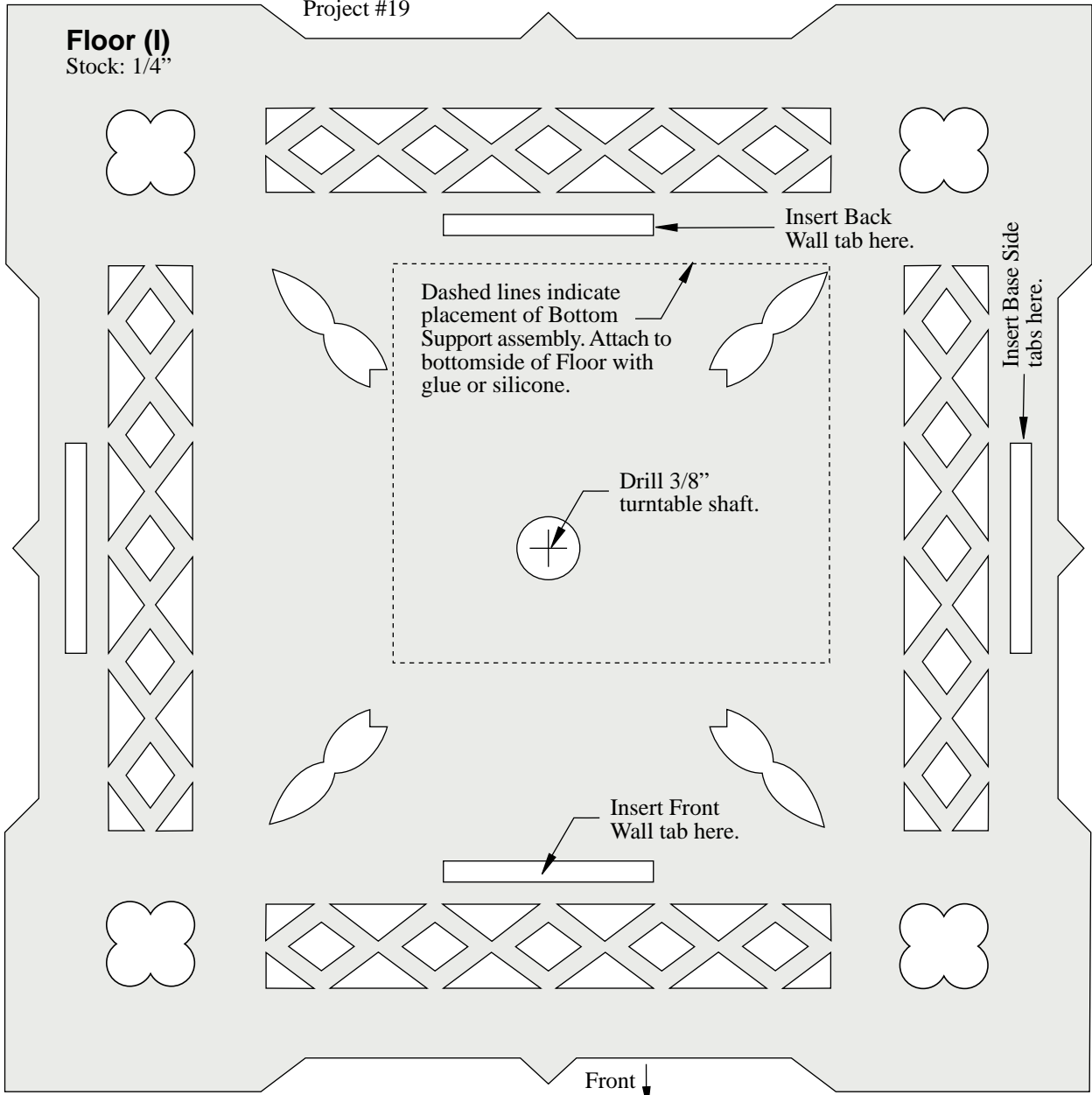

Dashed lines indicate placement of Bottom Support assembly. Attach to bottomside of Floor with glue or silicone.

Drill 3/8" turntable shaft.

Insert Back Wall tab here.

Insert Base Side tabs here.

Insert Front Wall tab here.

Front ↓

Turntable

Stock: 1/4", countersink the bottomside with a 1" forstner bit 1/16" deep. Secure the metal turntable with super glue or silicone.

Small dashed line indicates position of Turntable Overlay.

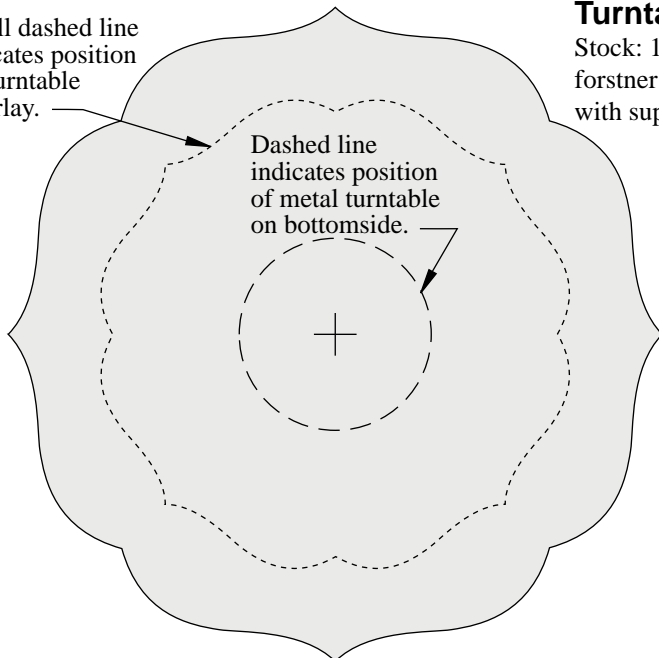

Dashed line indicates position of metal turntable on bottomside.

Bottom Support (J)

Stock: 1/4", cut 2

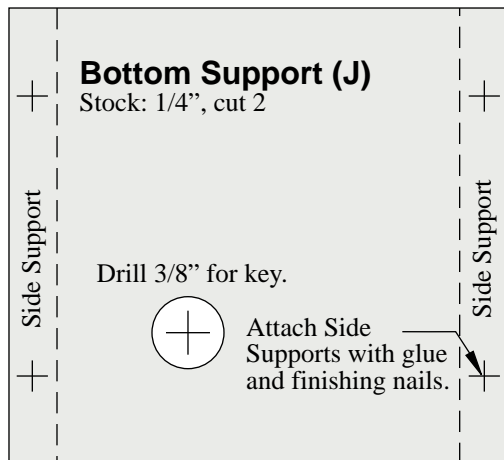

Drill 3/8" for key.

Attach Side Supports with glue and finishing nails.

Side Support

Side Support

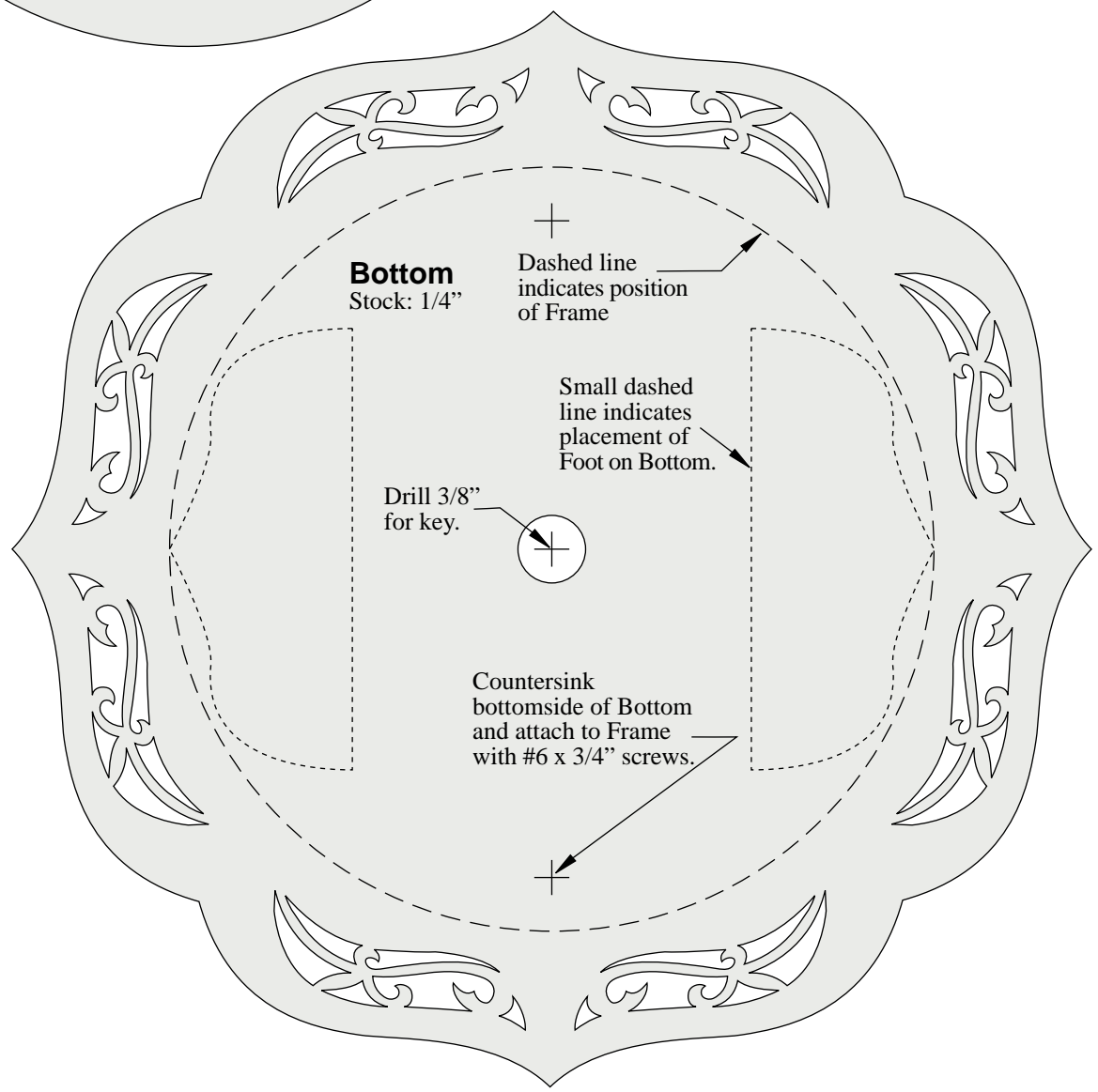
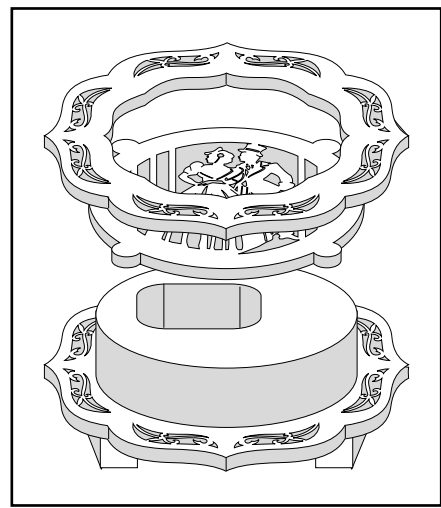
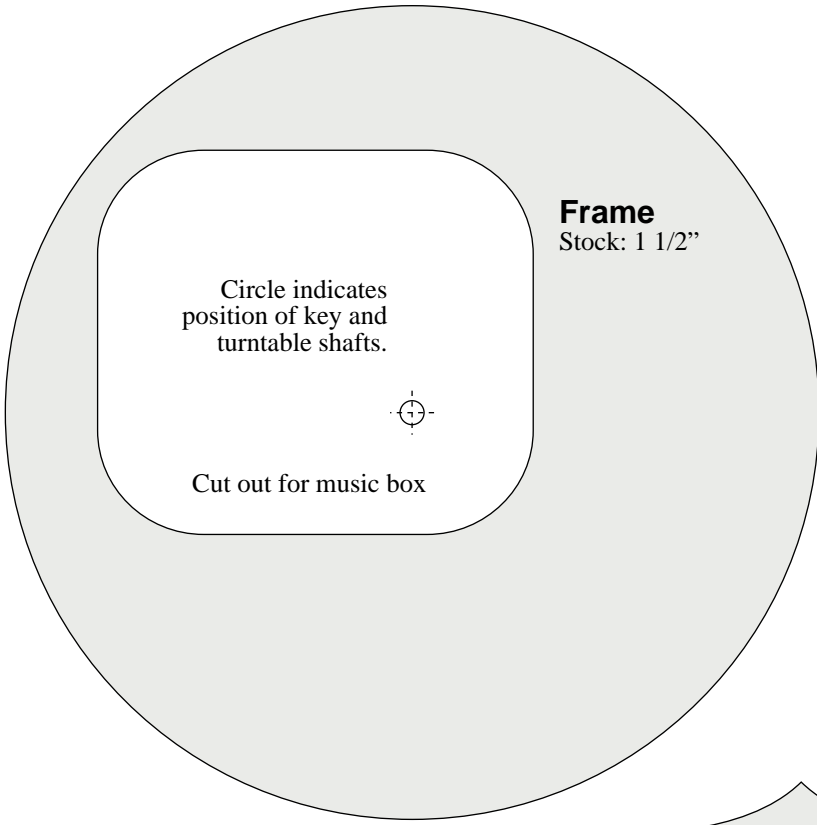

Project #20

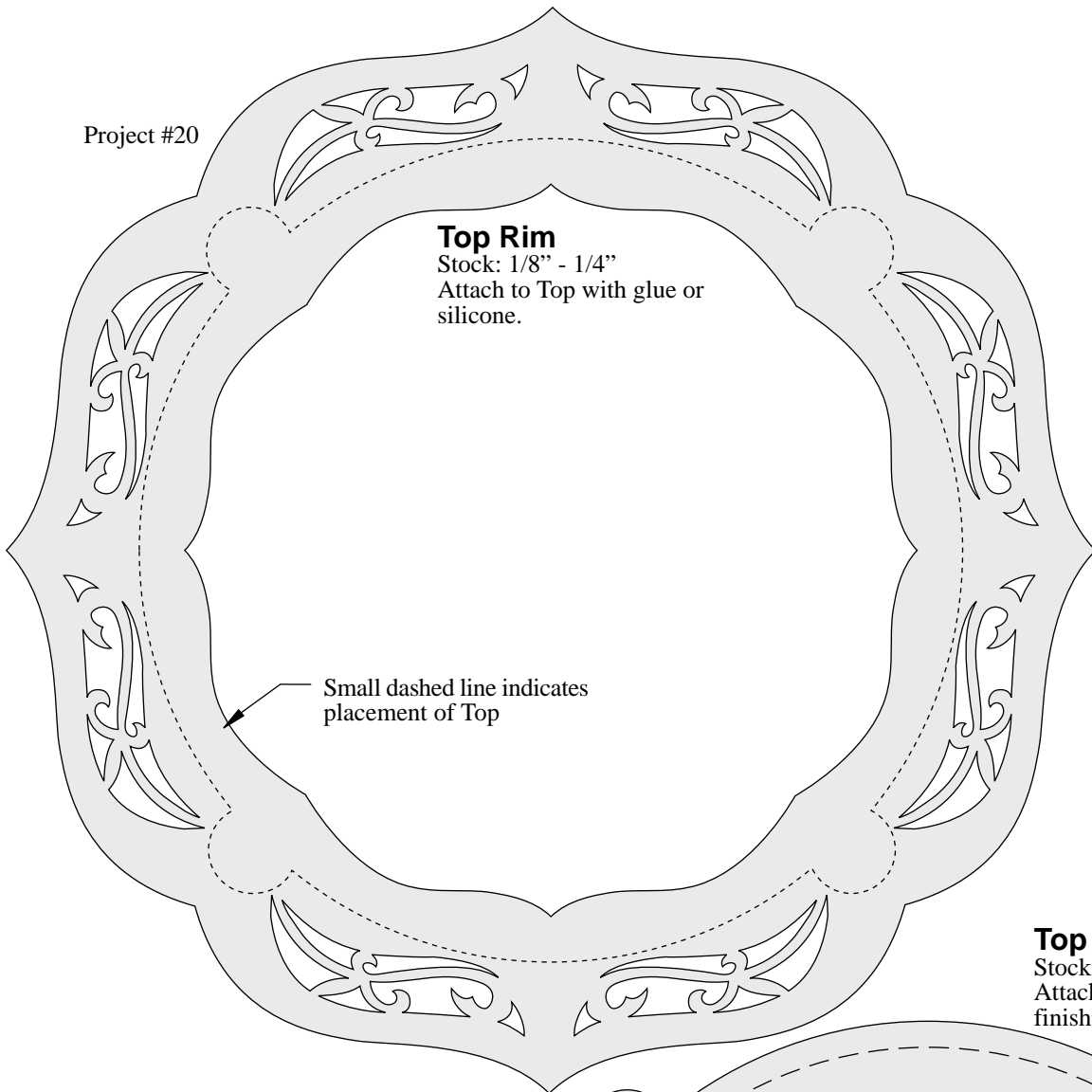

Top Rim
Stock: 1/8" - 1/4"
Attach to Top with glue or silicone.

Small dashed line indicates placement of Top

Top
Stock: 1/8" - 1/4"
Attach to Frame with glue and finishing nails or silicone.

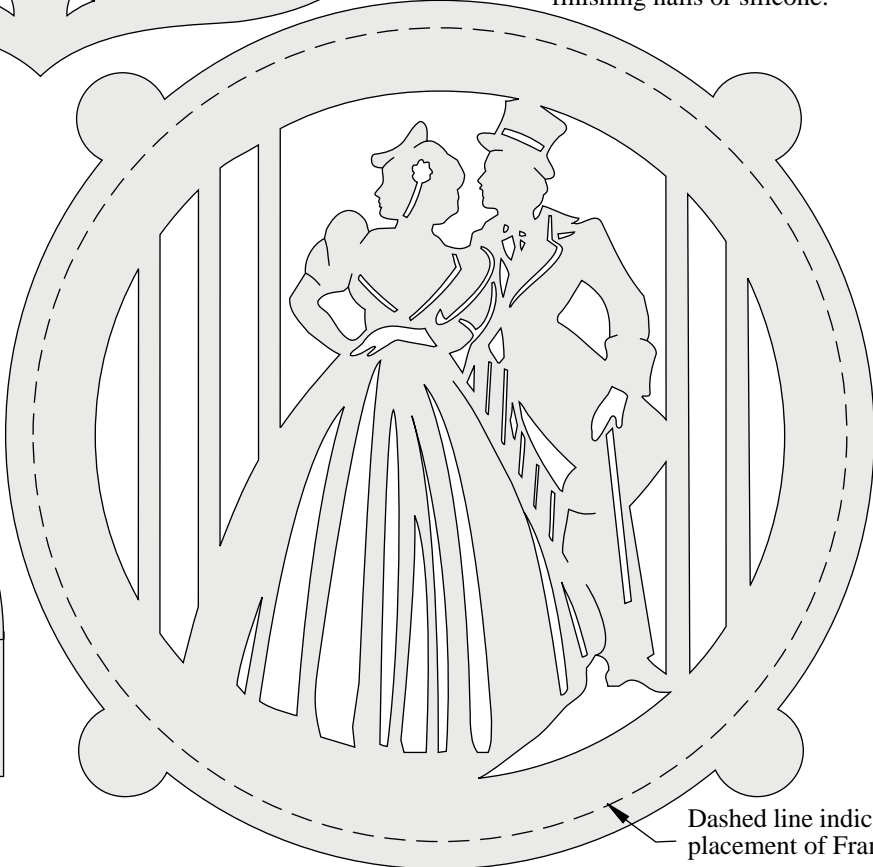

Dashed line indicates placement of Frame

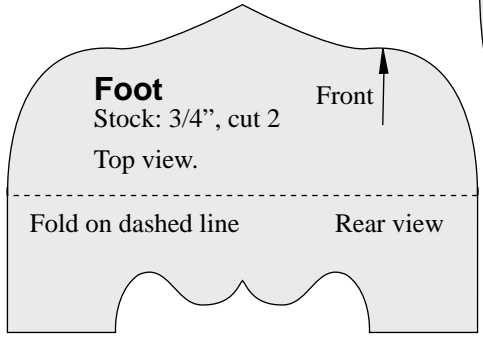

Foot
Stock: 3/4", cut 2
Top view.

Front

Fold on dashed line

Rear view

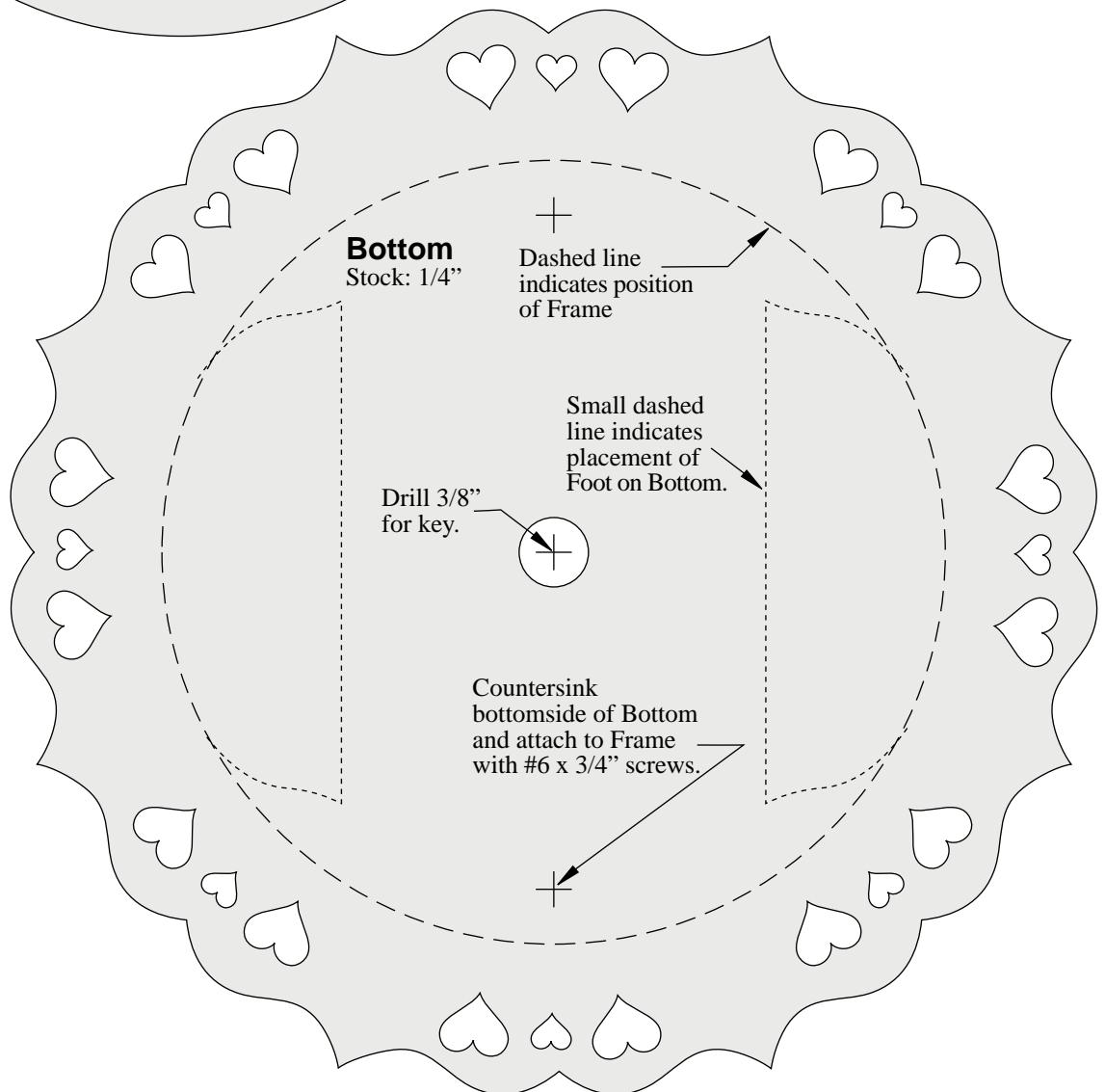
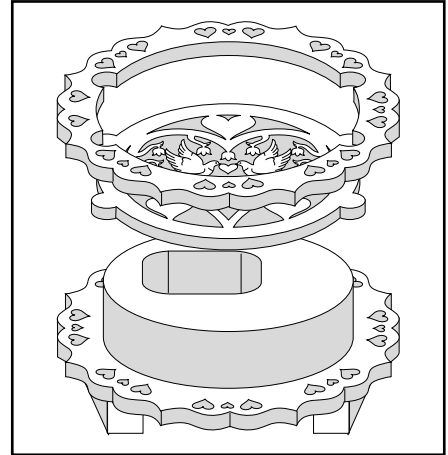
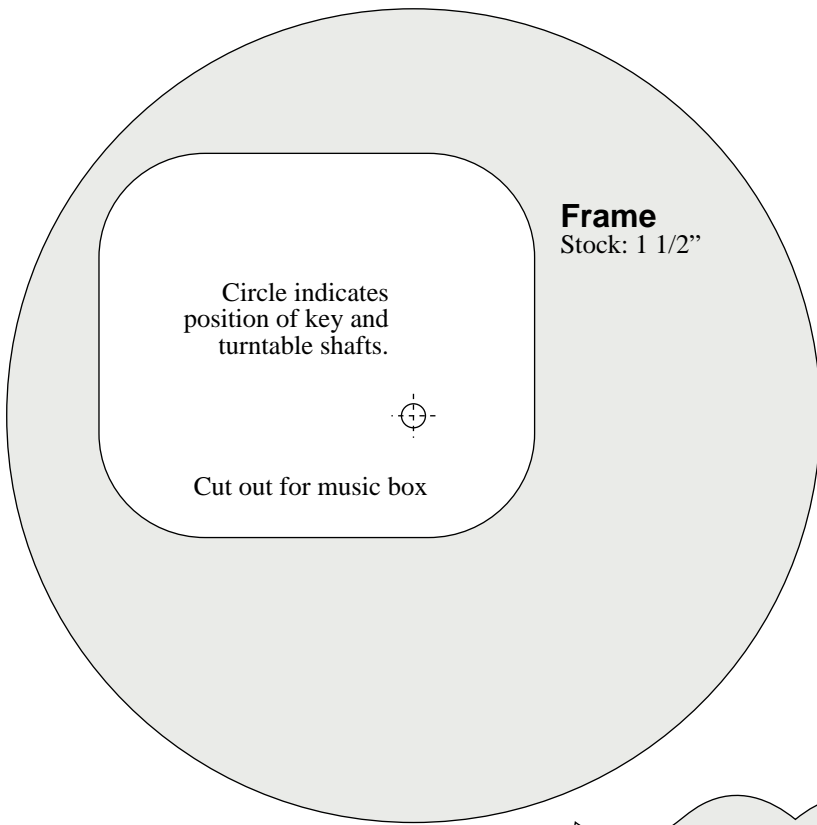

Project #21

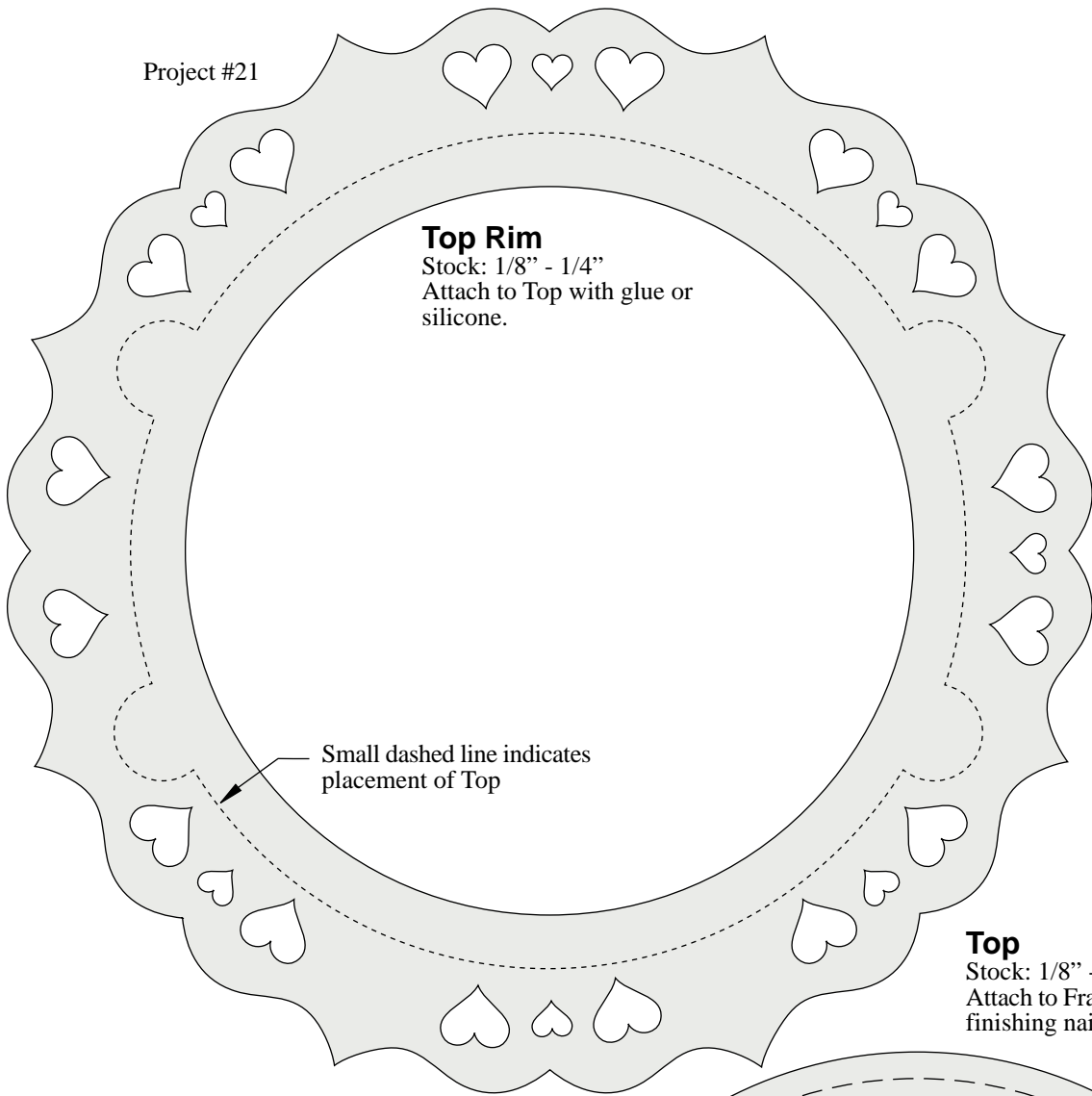

Top Rim

Stock: 1/8" - 1/4"

Attach to Top with glue or silicone.

Top

Stock: 1/8" - 1/4"

Attach to Frame with glue and finishing nails or silicone.

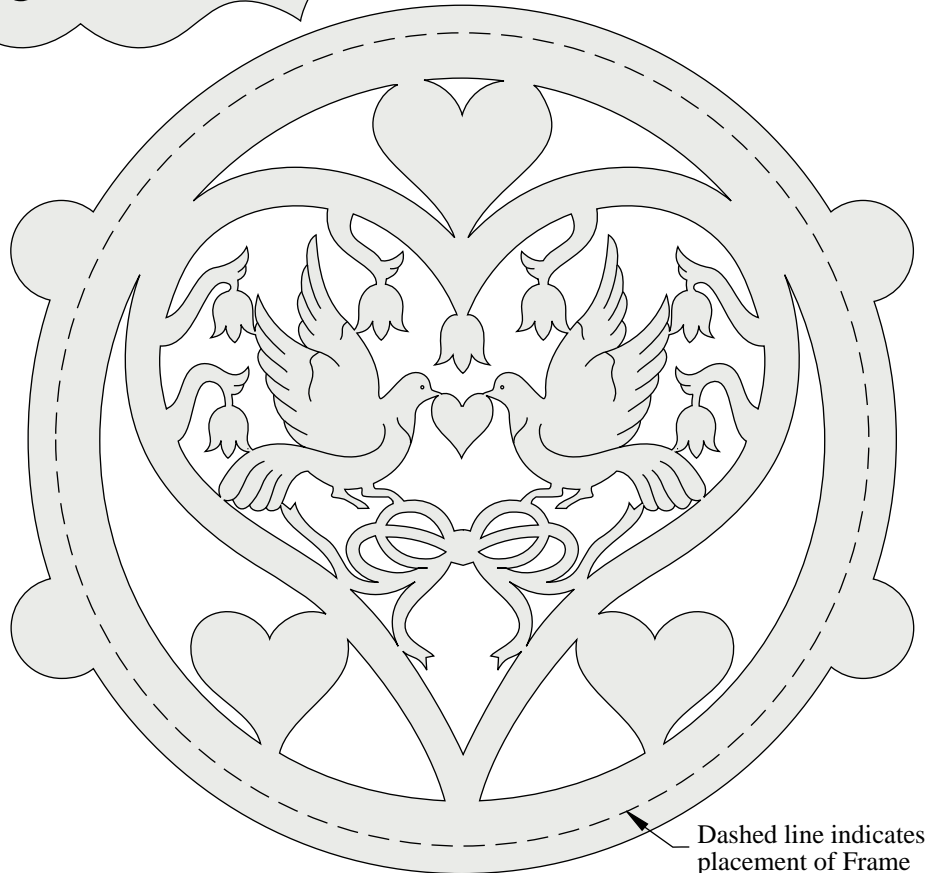
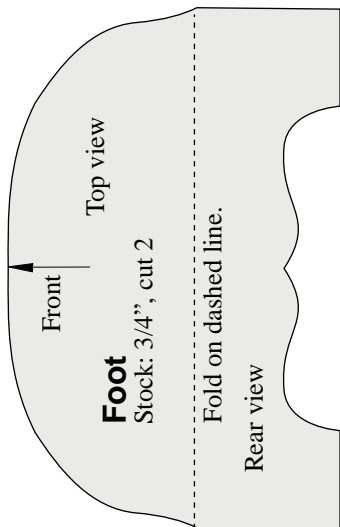

Dashed line indicates placement of Frame

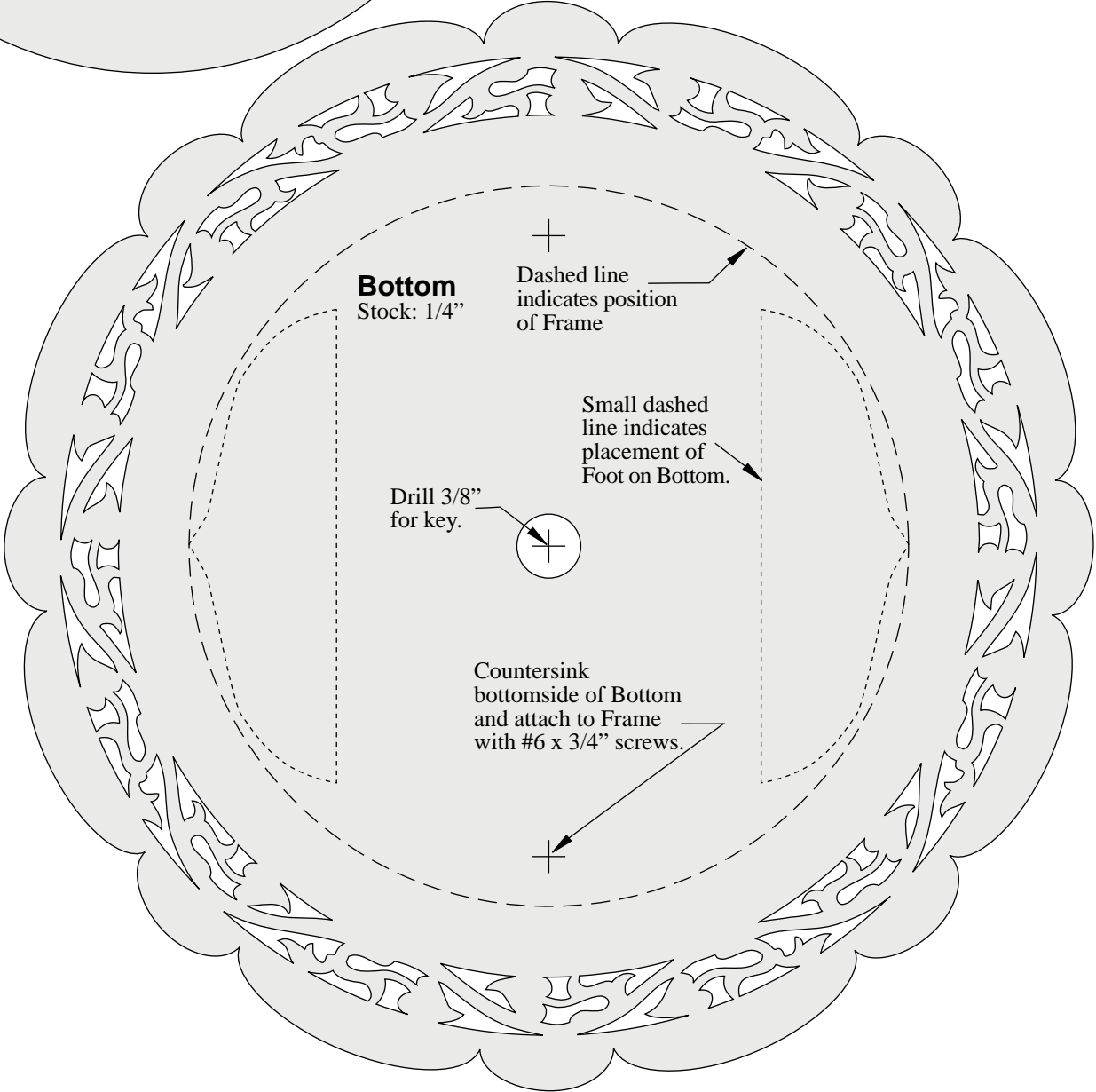
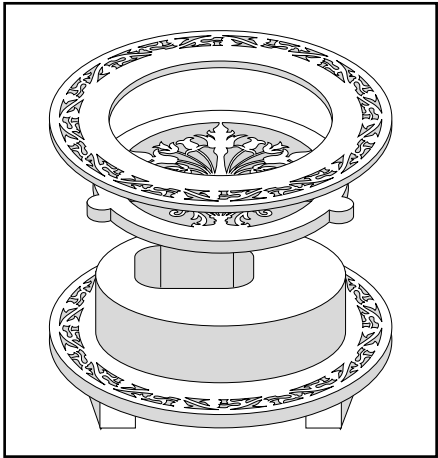
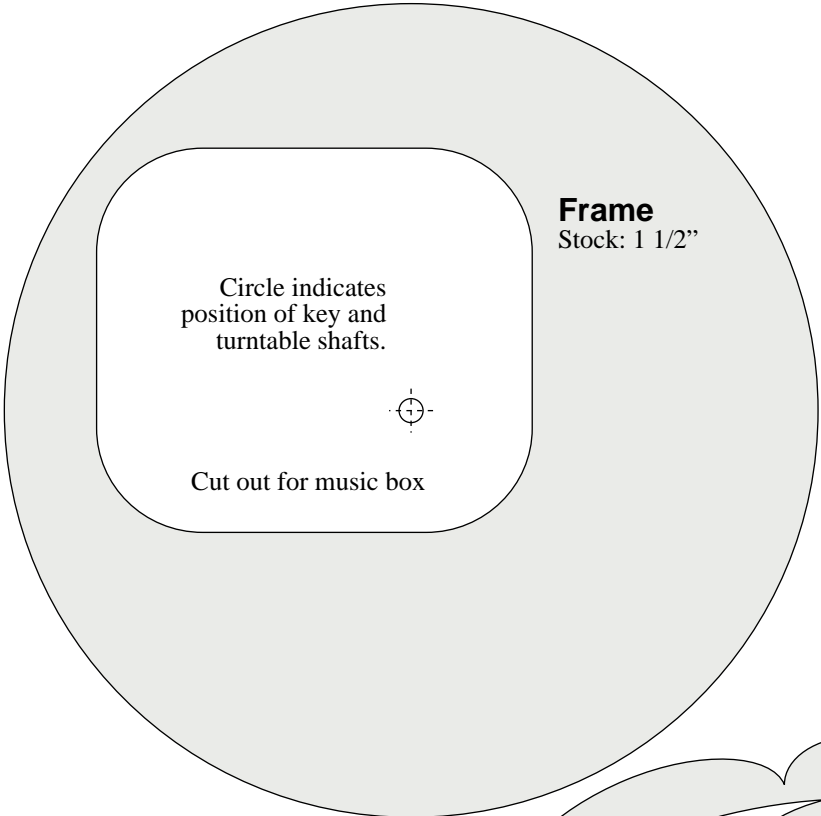

Project #22

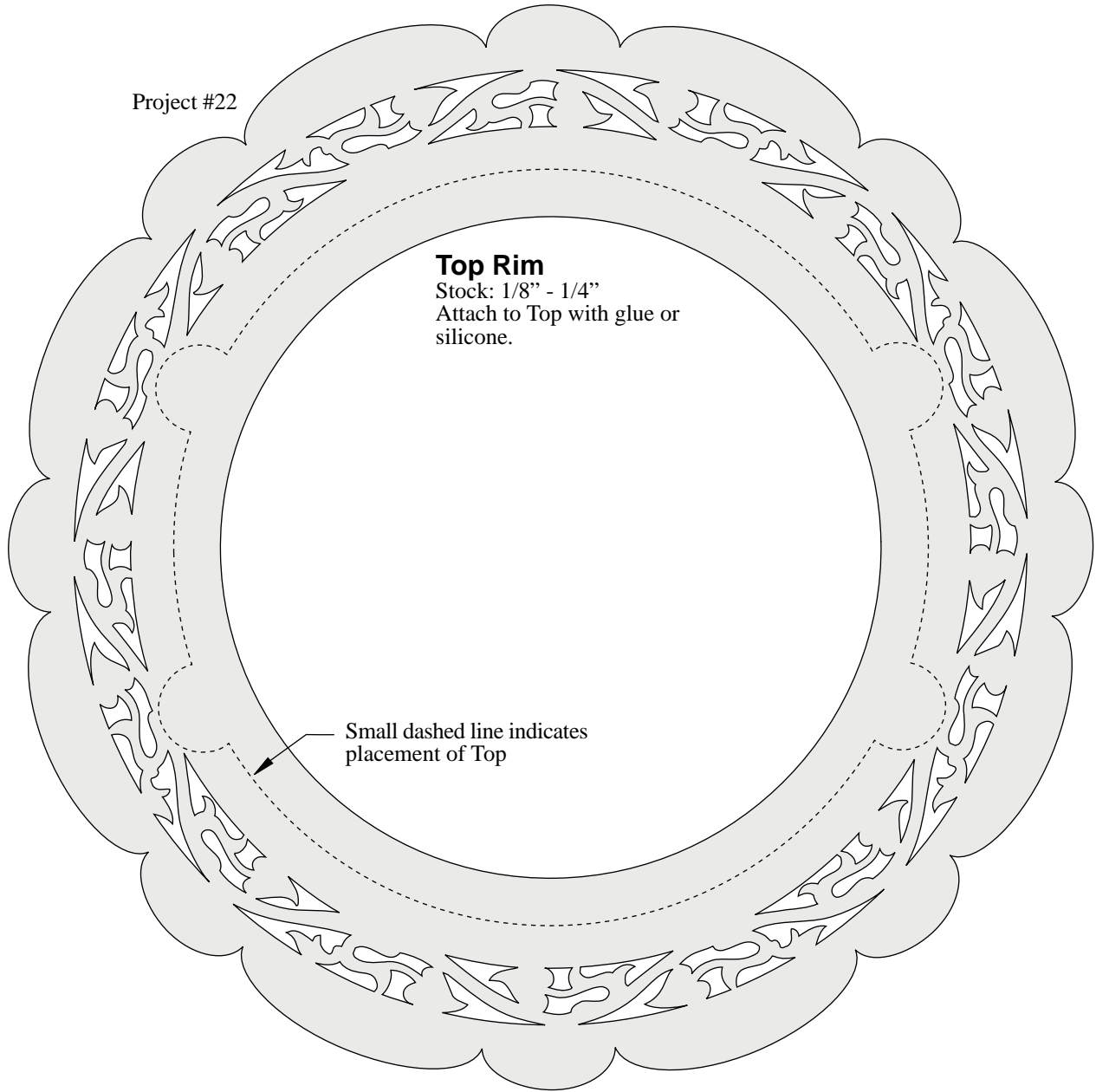

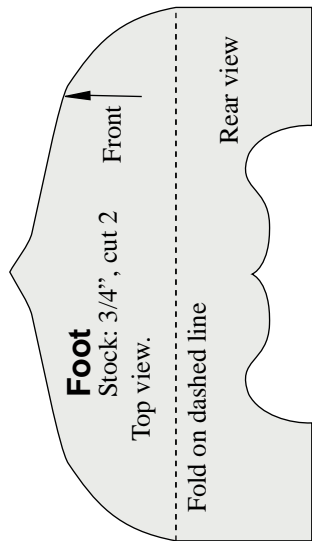

Top
Stock: 1/8" - 1/4"
Attach to Frame with glue and finishing nails or silicone.

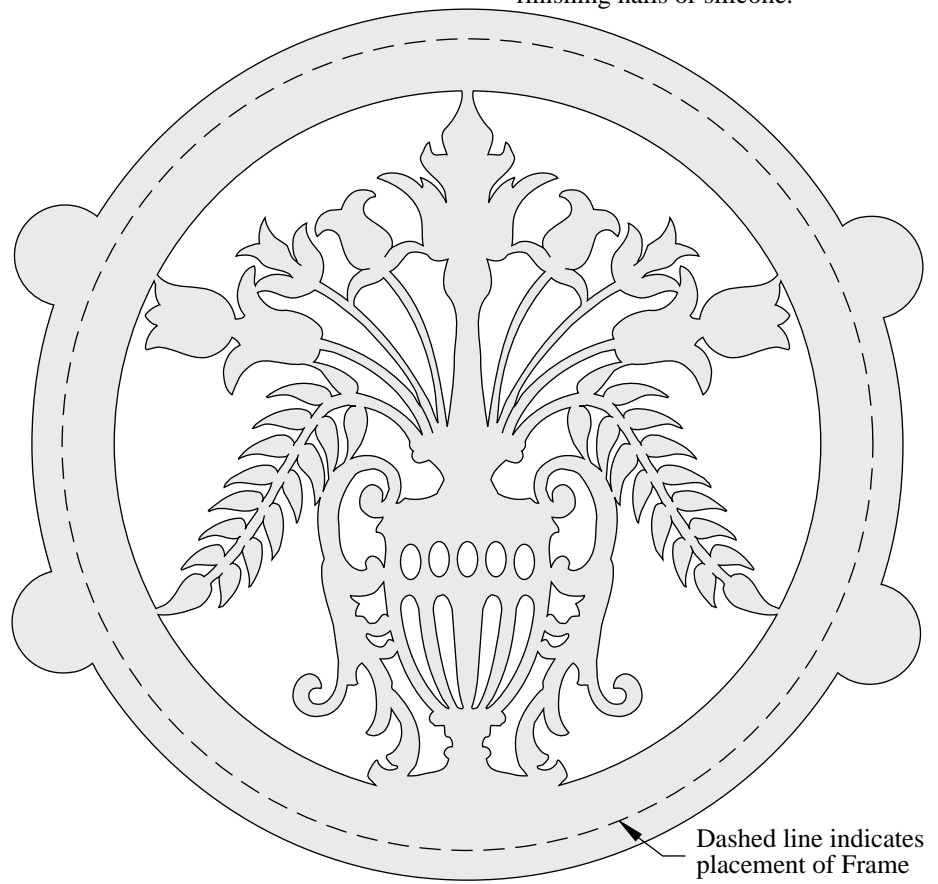

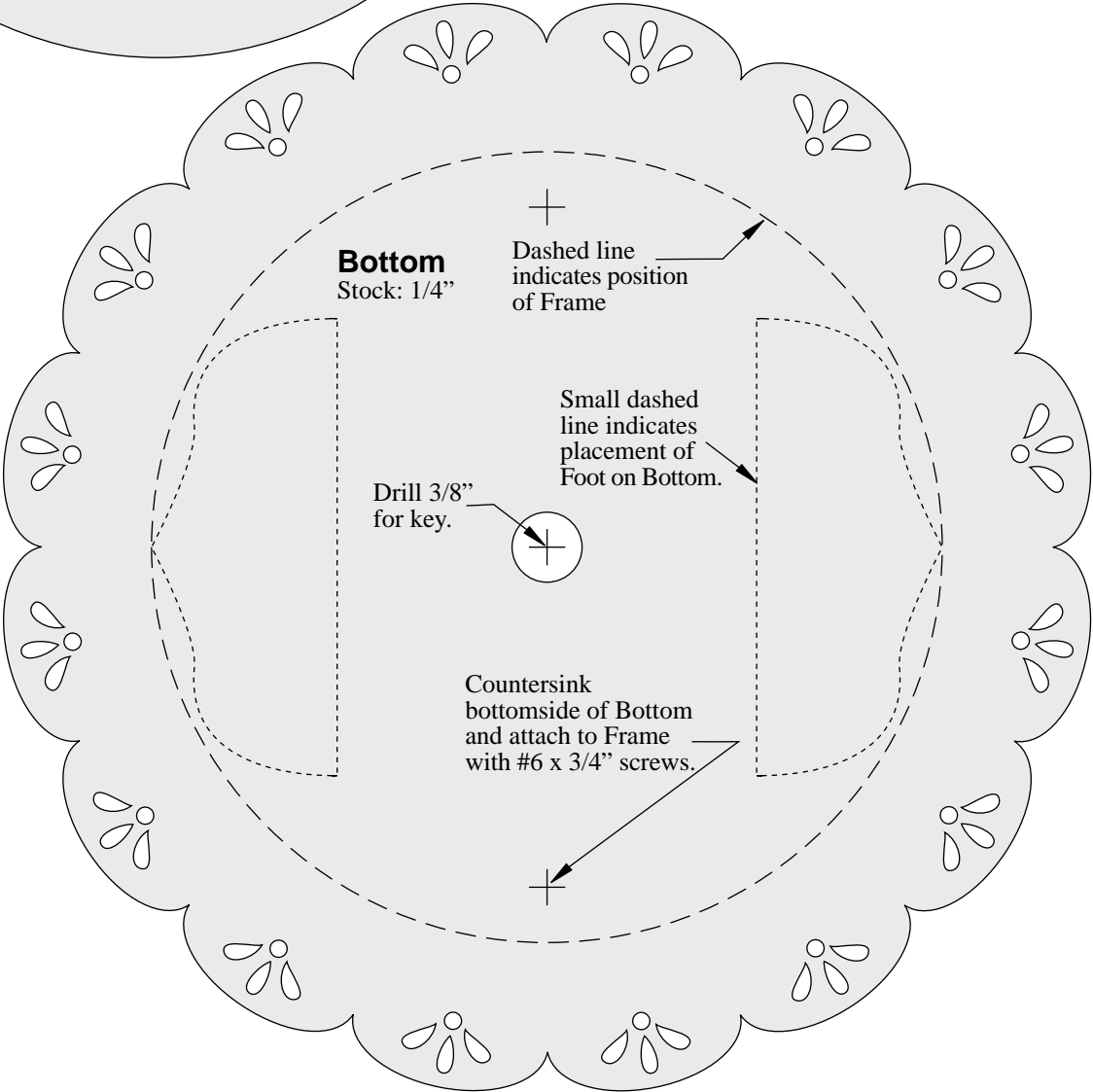
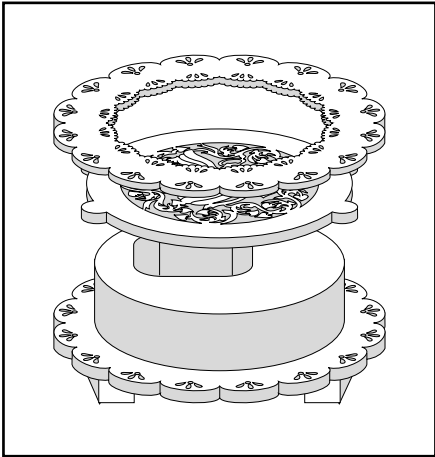
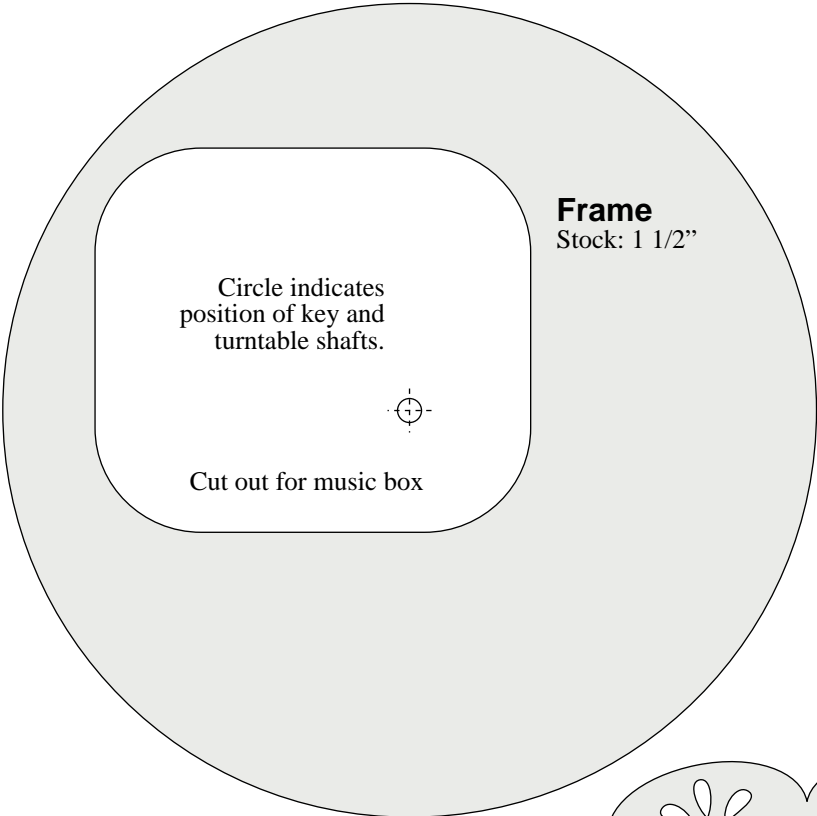

Project #23

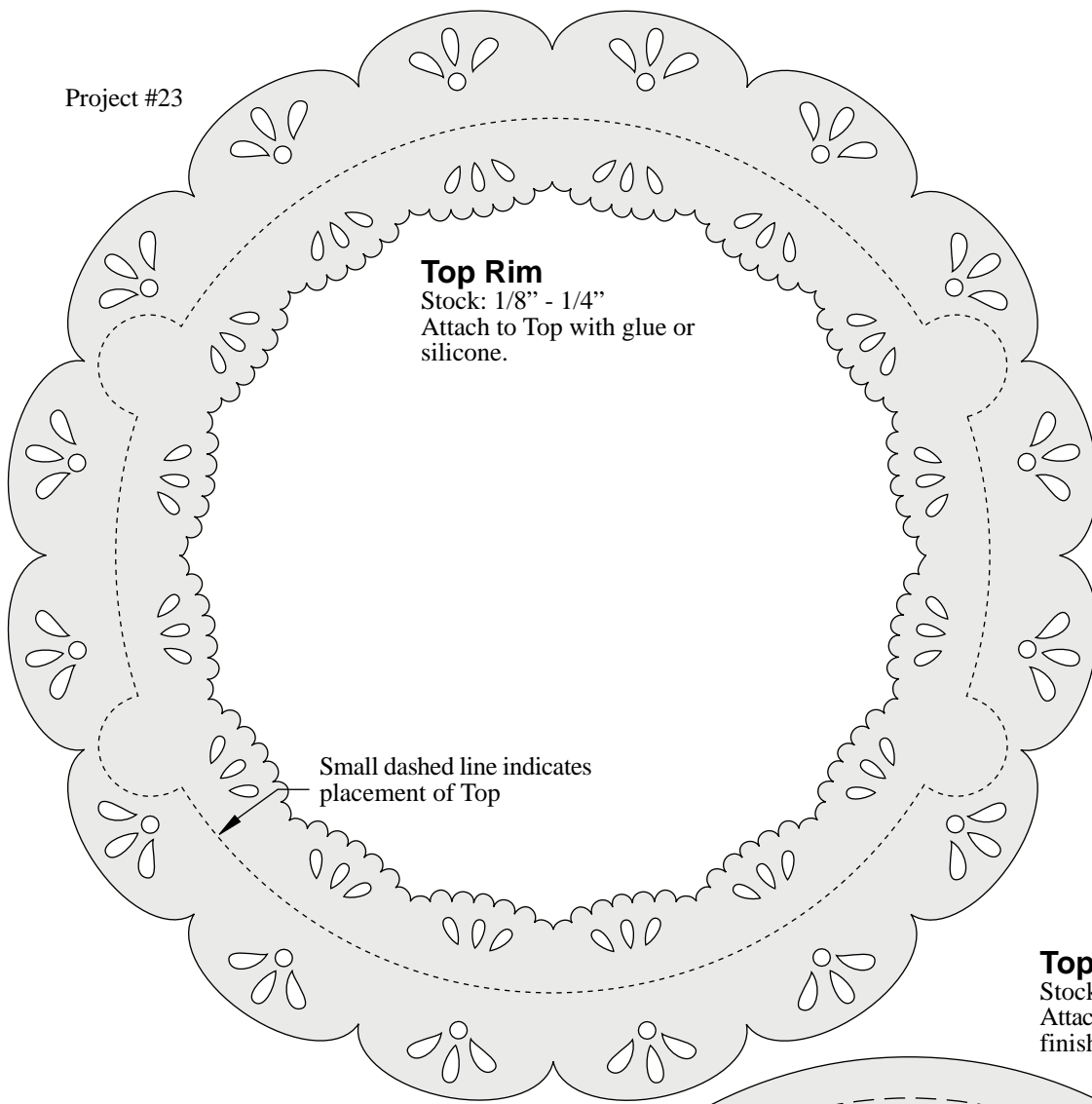

Top
Stock: 1/8" - 1/4"
Attach to Frame with glue and finishing nails or silicone.

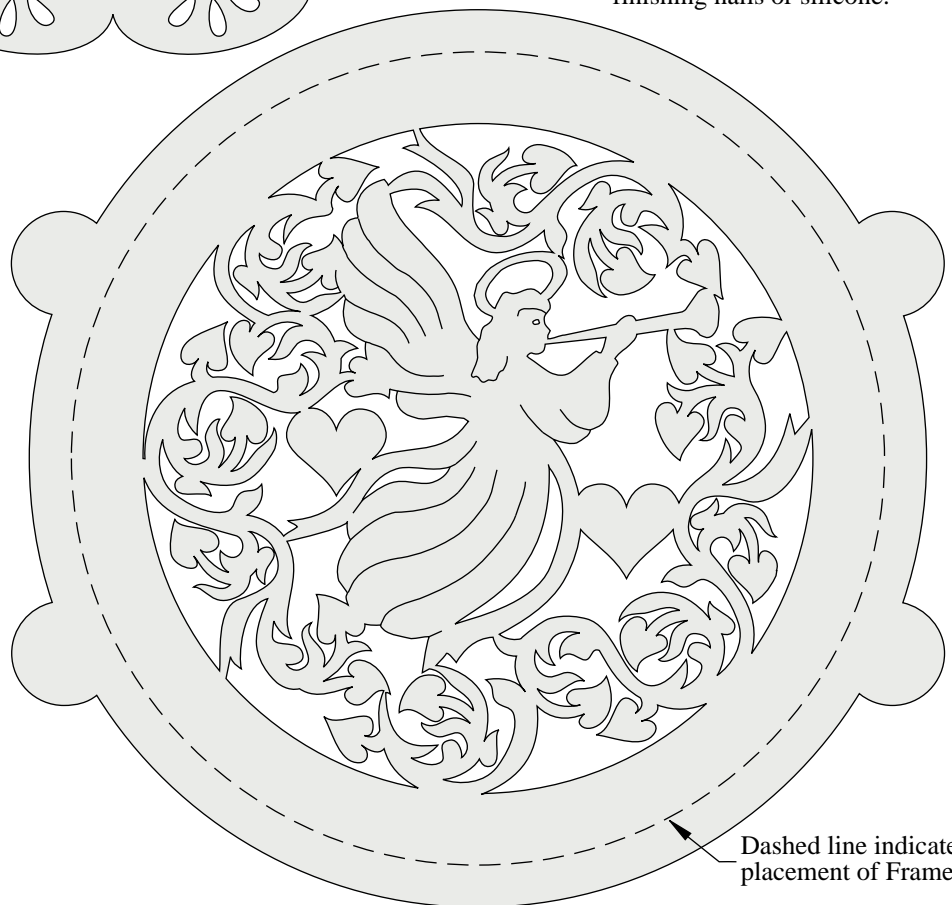
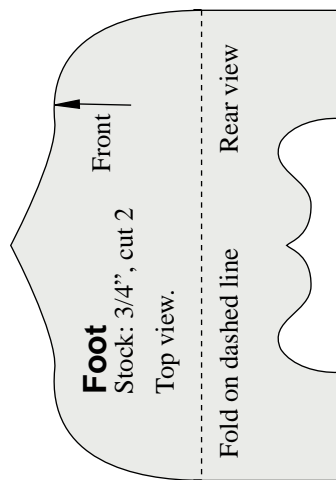

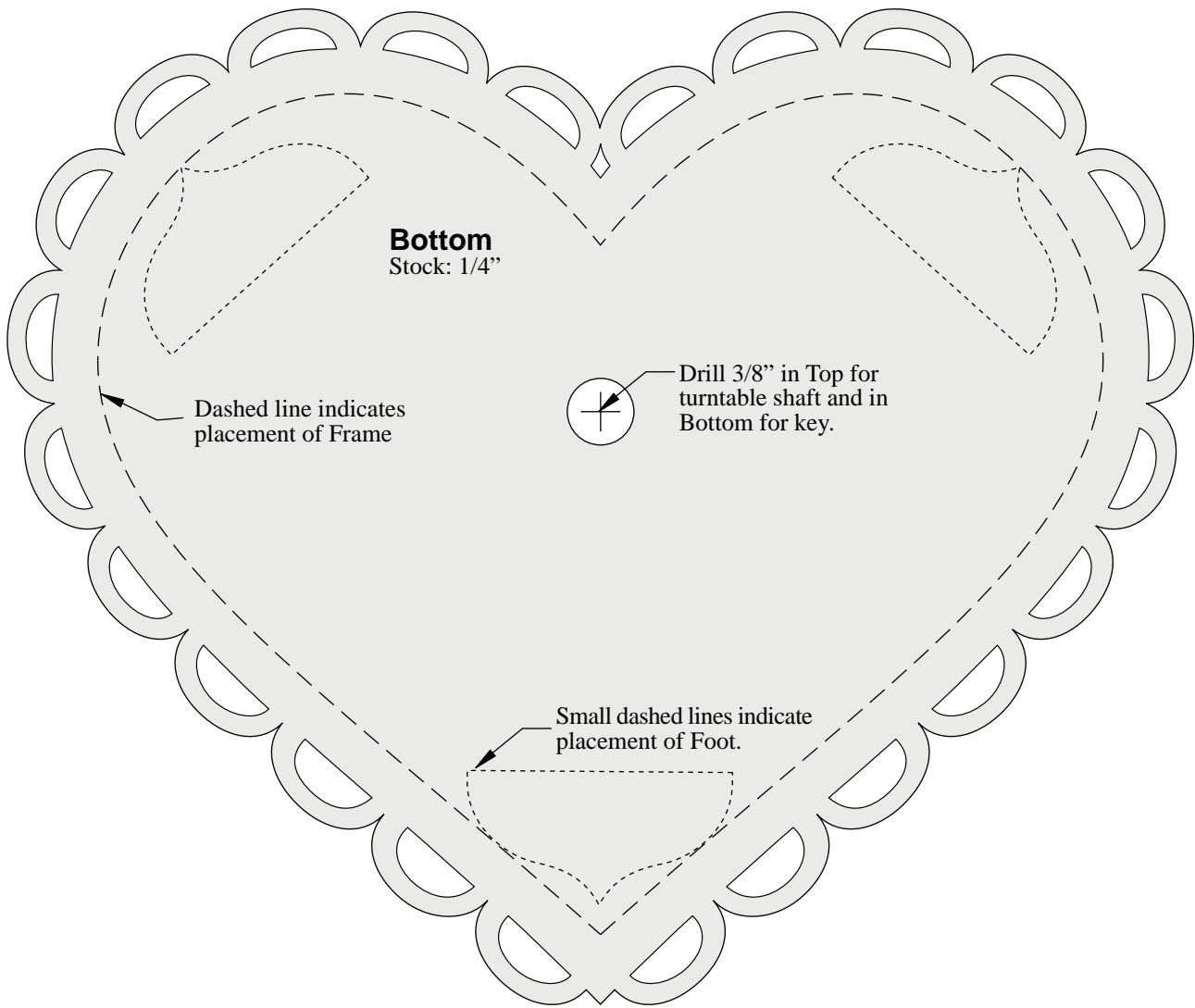
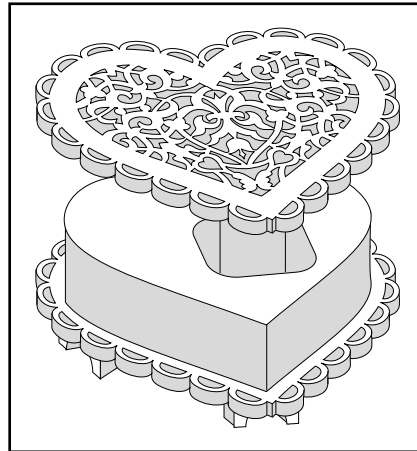
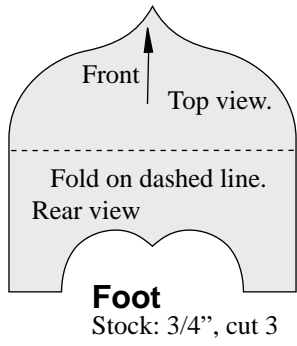

Project #24

Frame

Stock: 1 1/2"

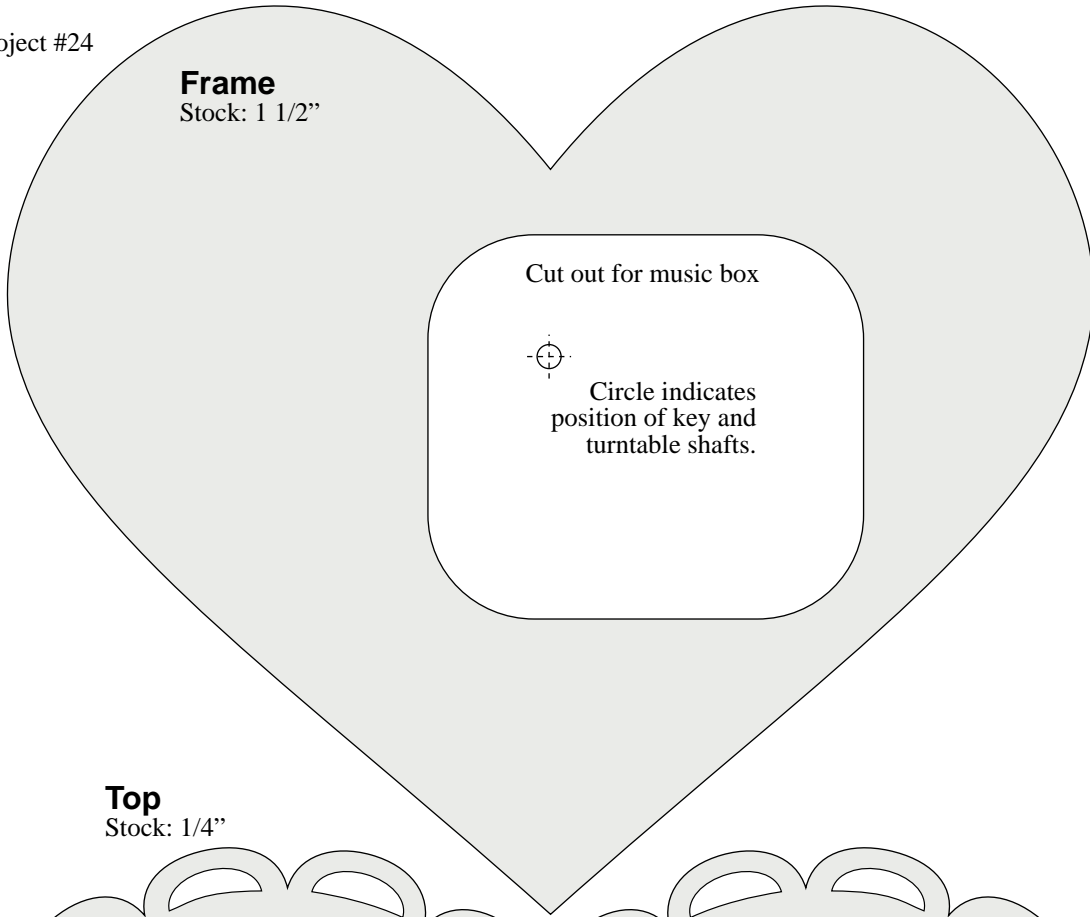

Cut out for music box



Circle indicates position of key and turntable shafts.

Top

Stock: 1/4"

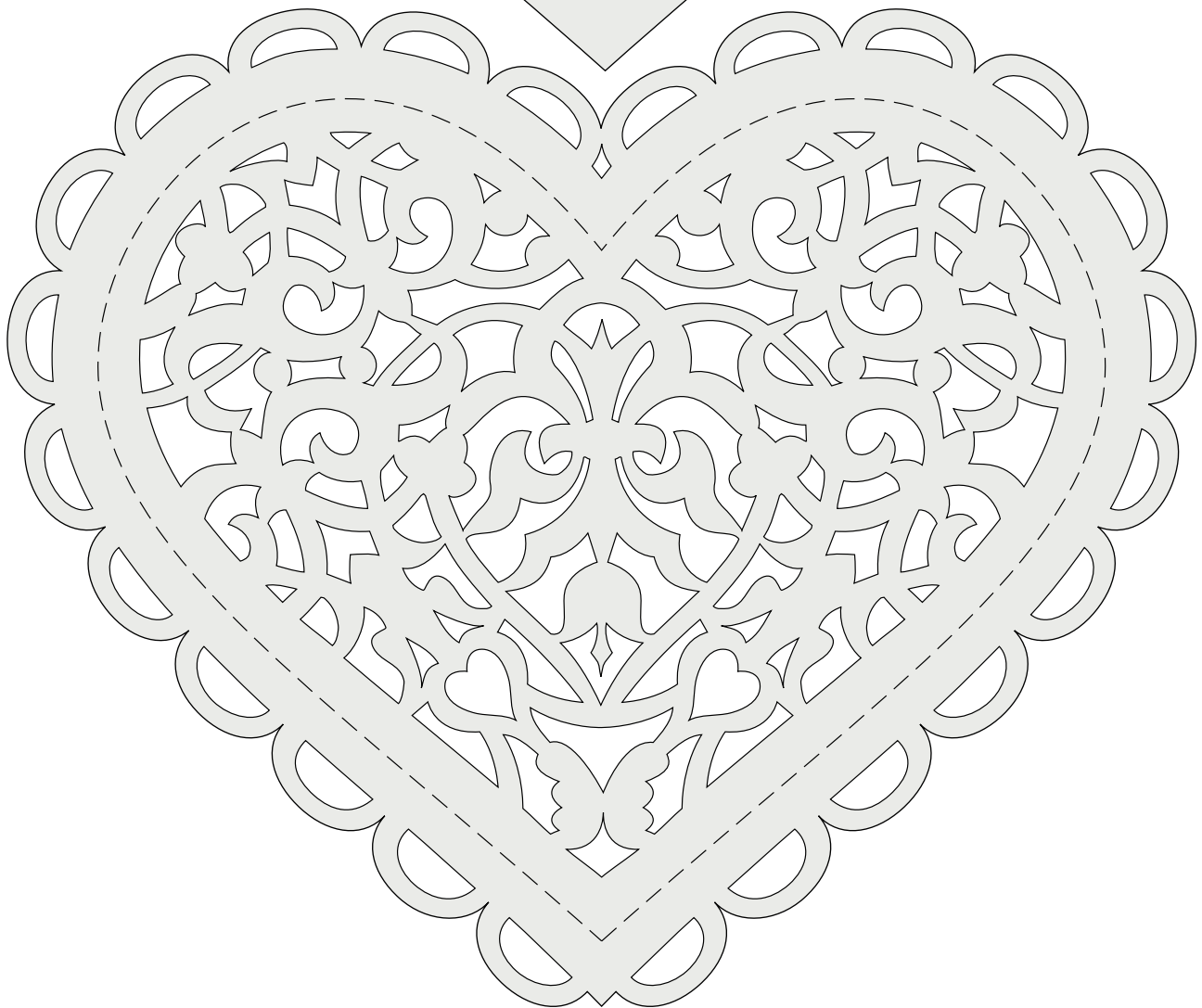

Project #25

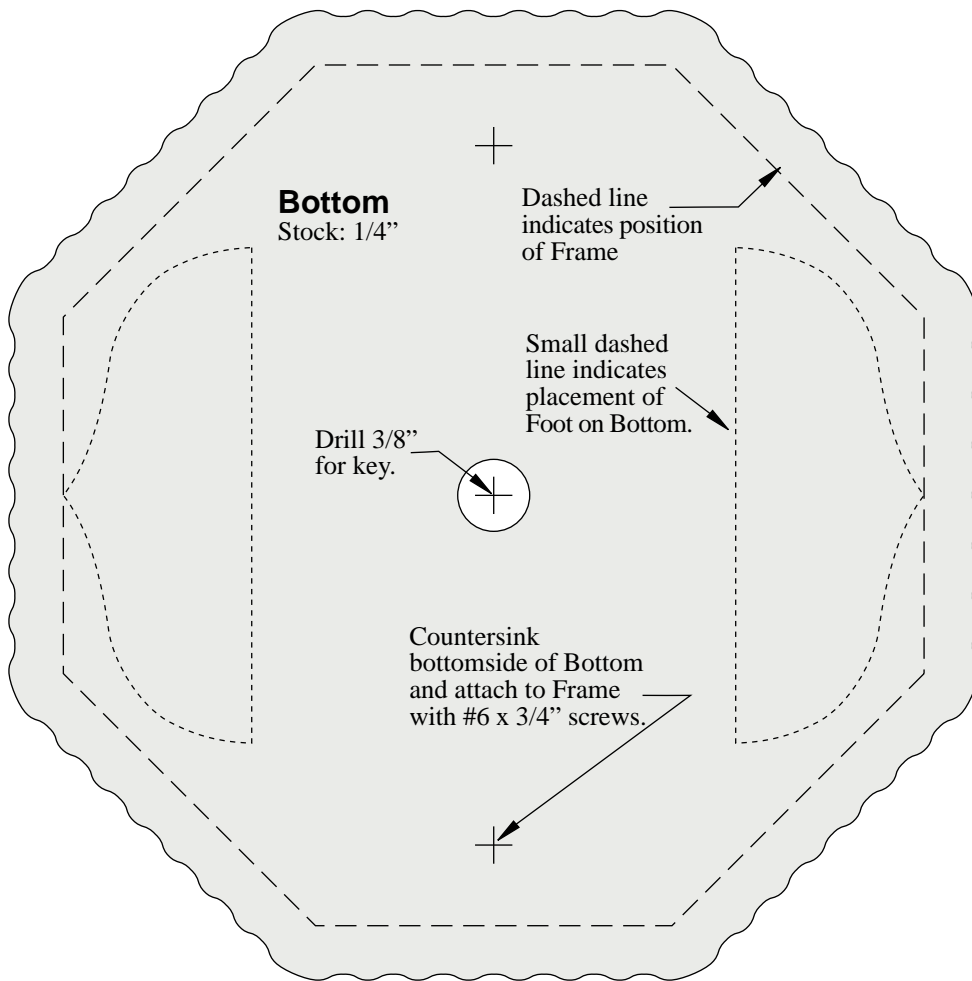
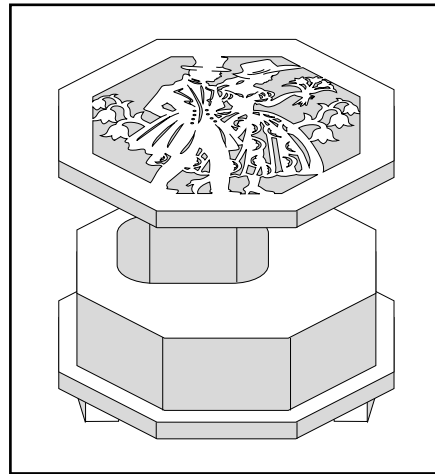
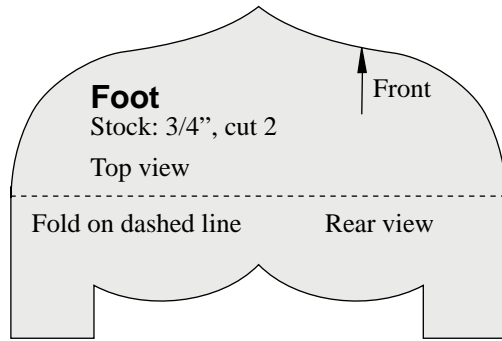

Project #25

Top
Stock: 1/4"



Frame
Stock: 1 1/2"

Circle indicates
position of key and
turntable shafts.



Cut out for music box

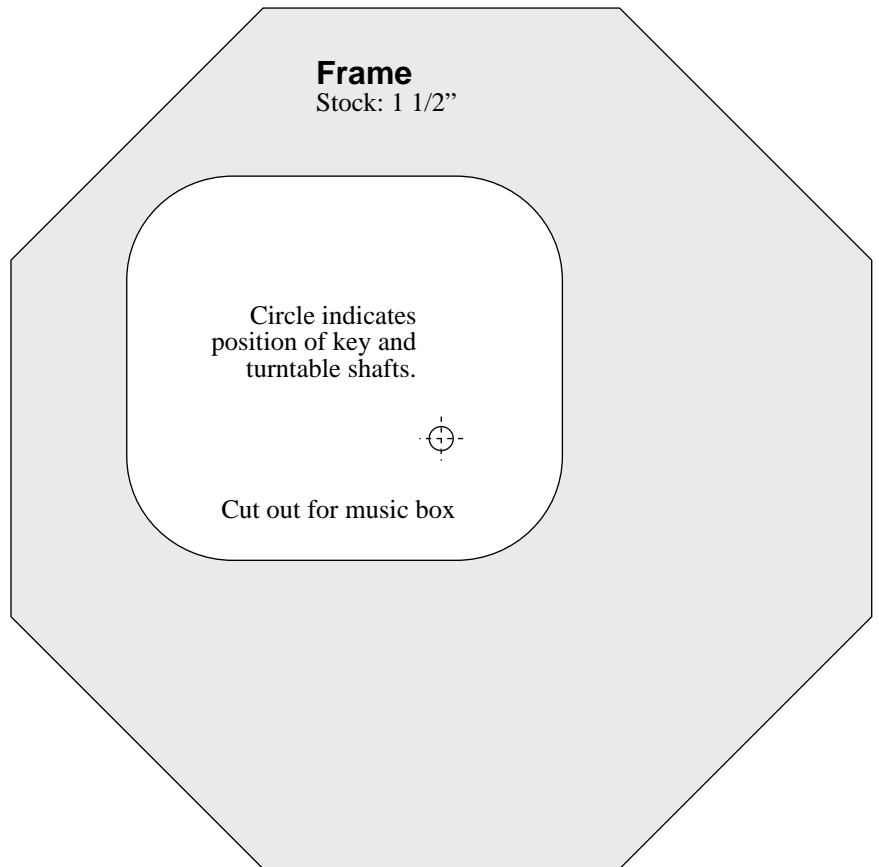

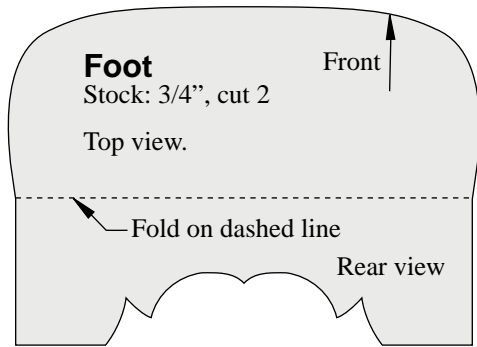

Project #26

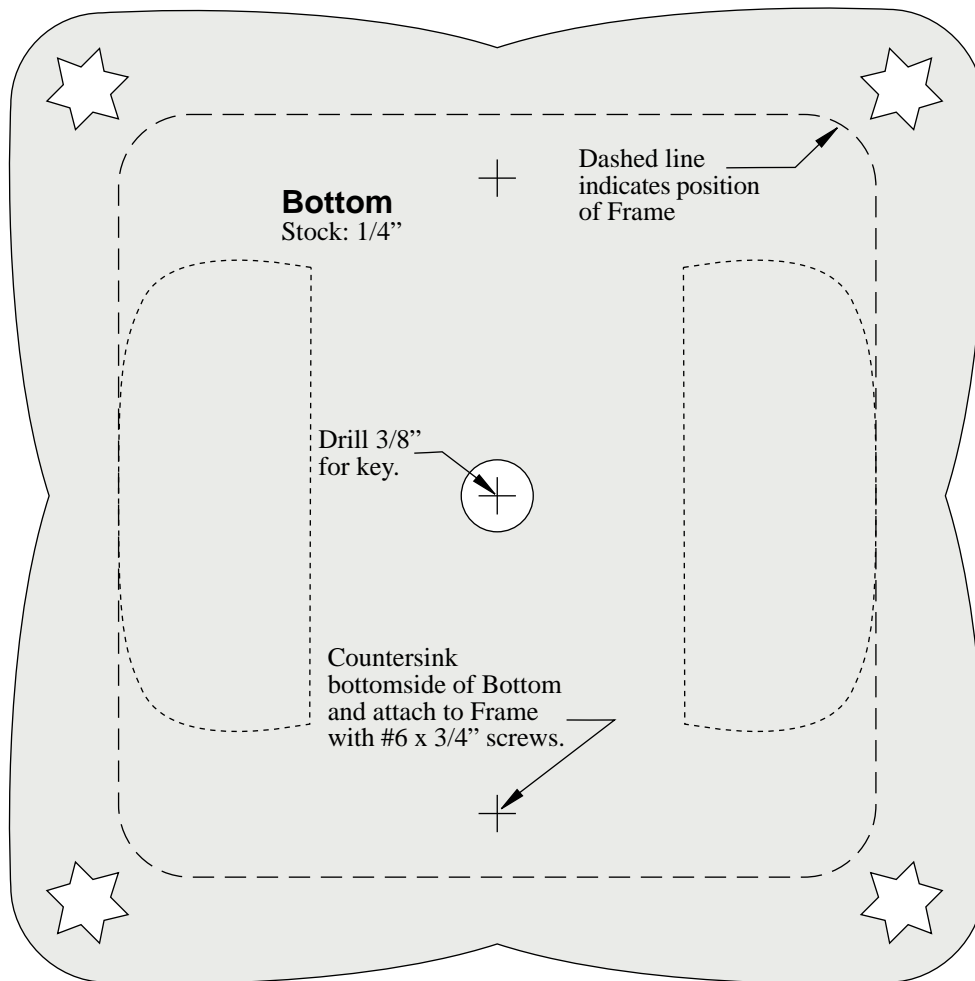
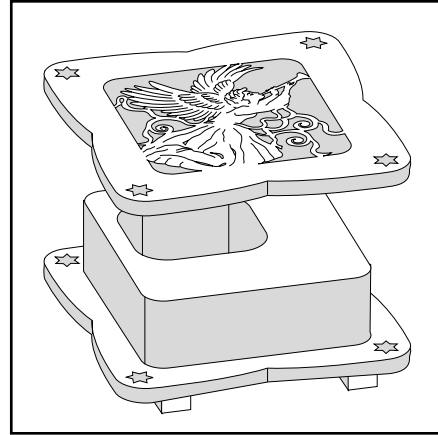

Project #26

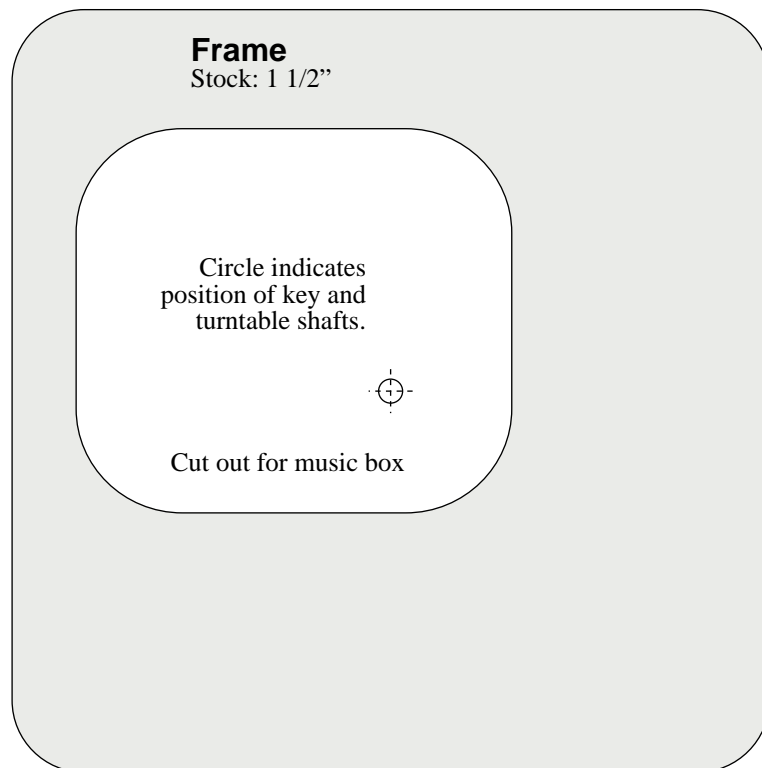

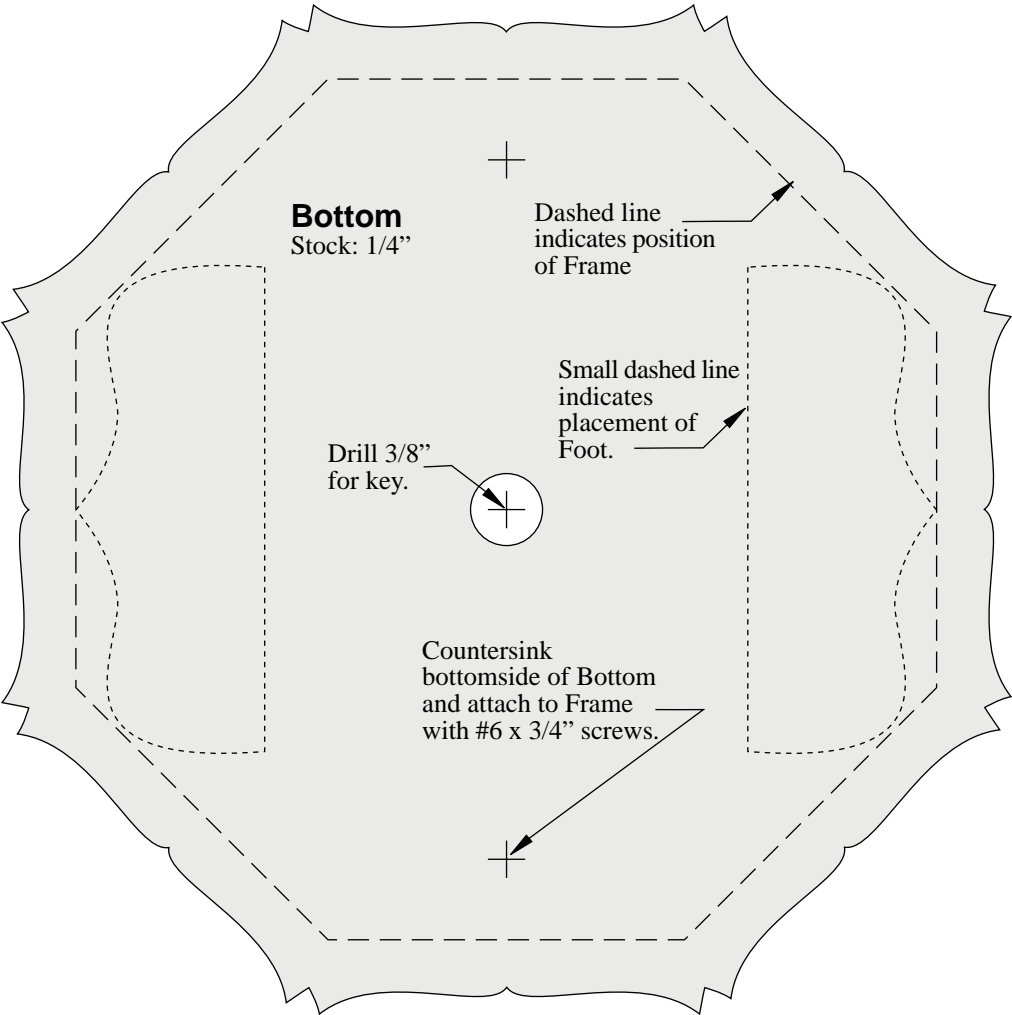
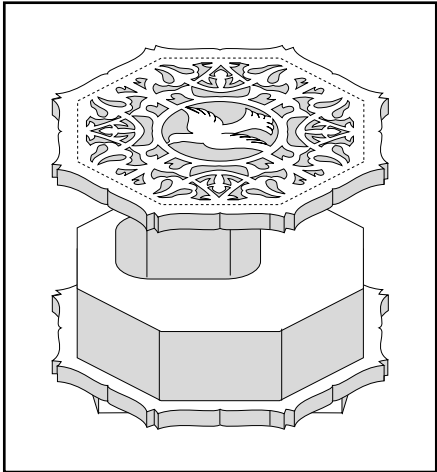
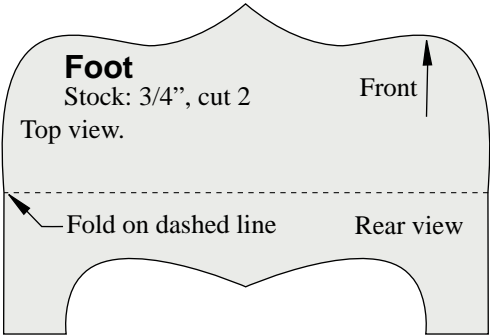

Project #27

Top
Stock: 1/4"

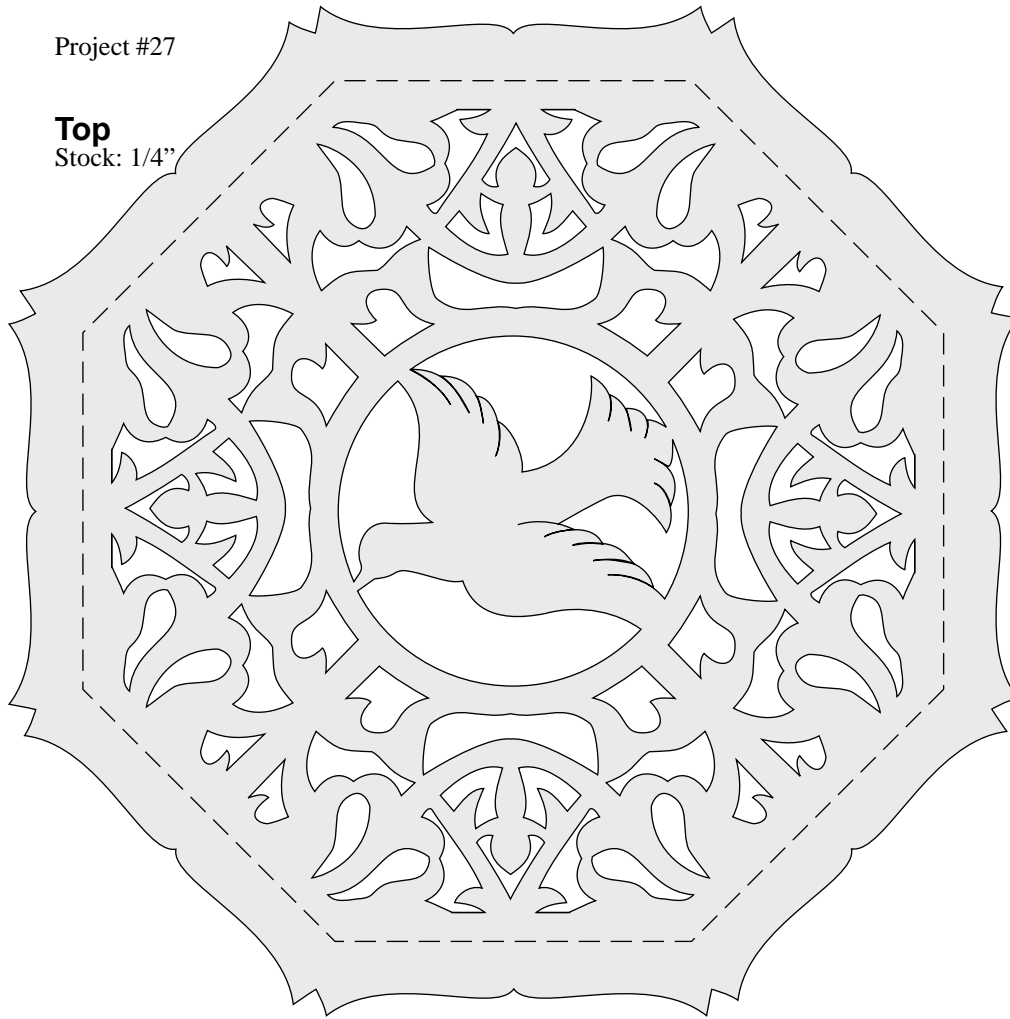

Frame
Stock: 1 1/2"

Circle indicates
position of key and
turntable shafts.



Cut out for music box

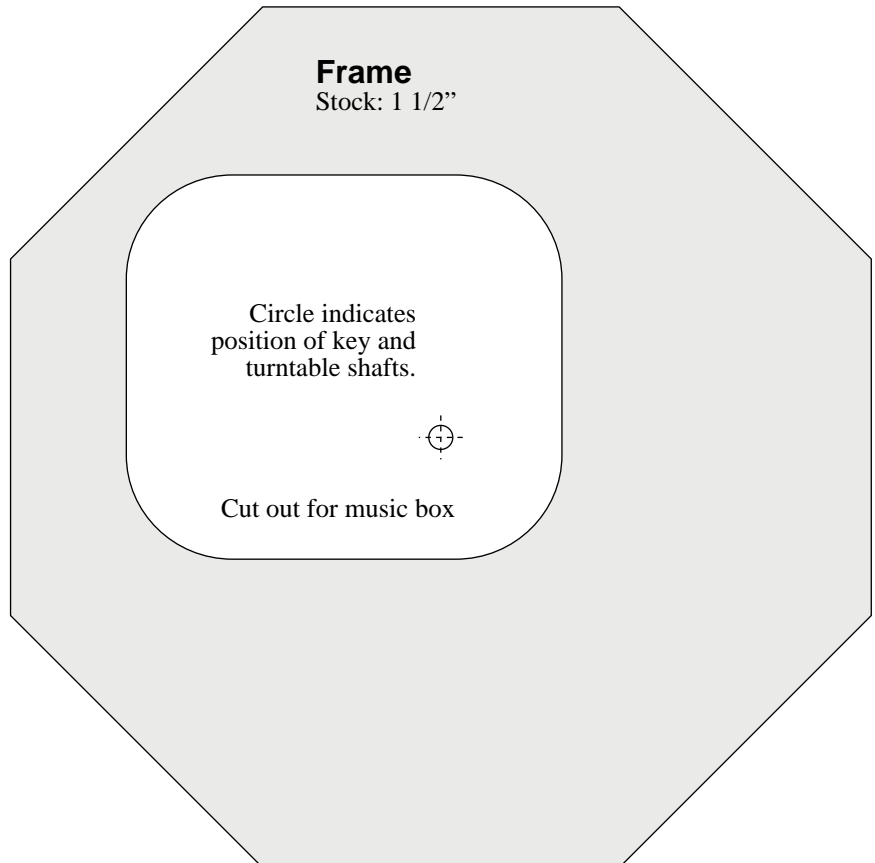

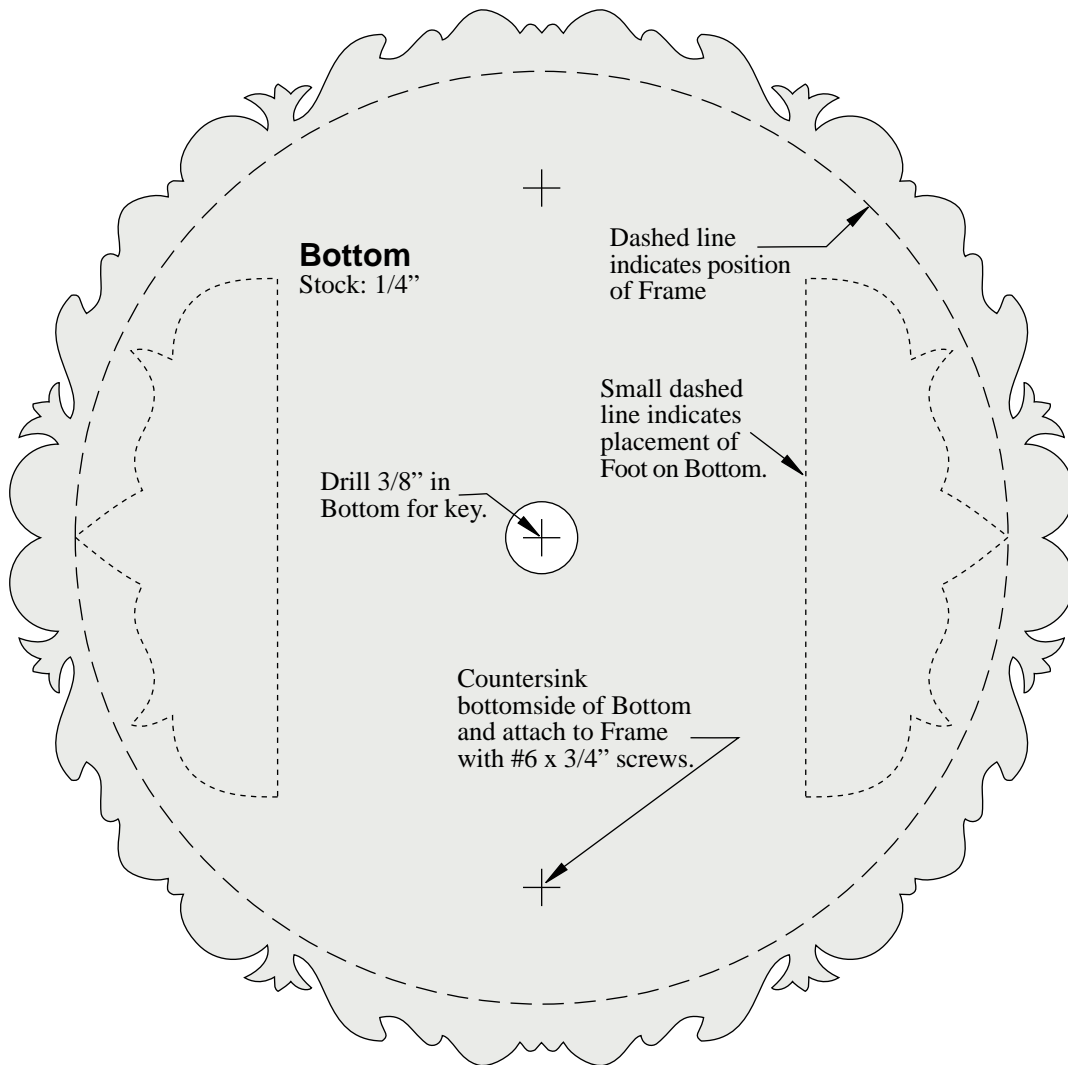
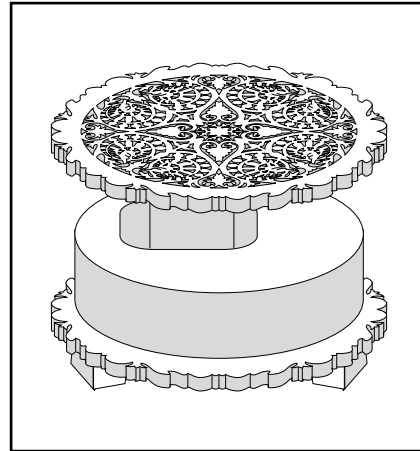
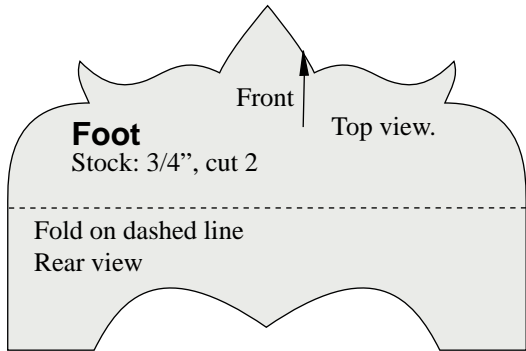

Project #28

Top
Stock: 1/4"

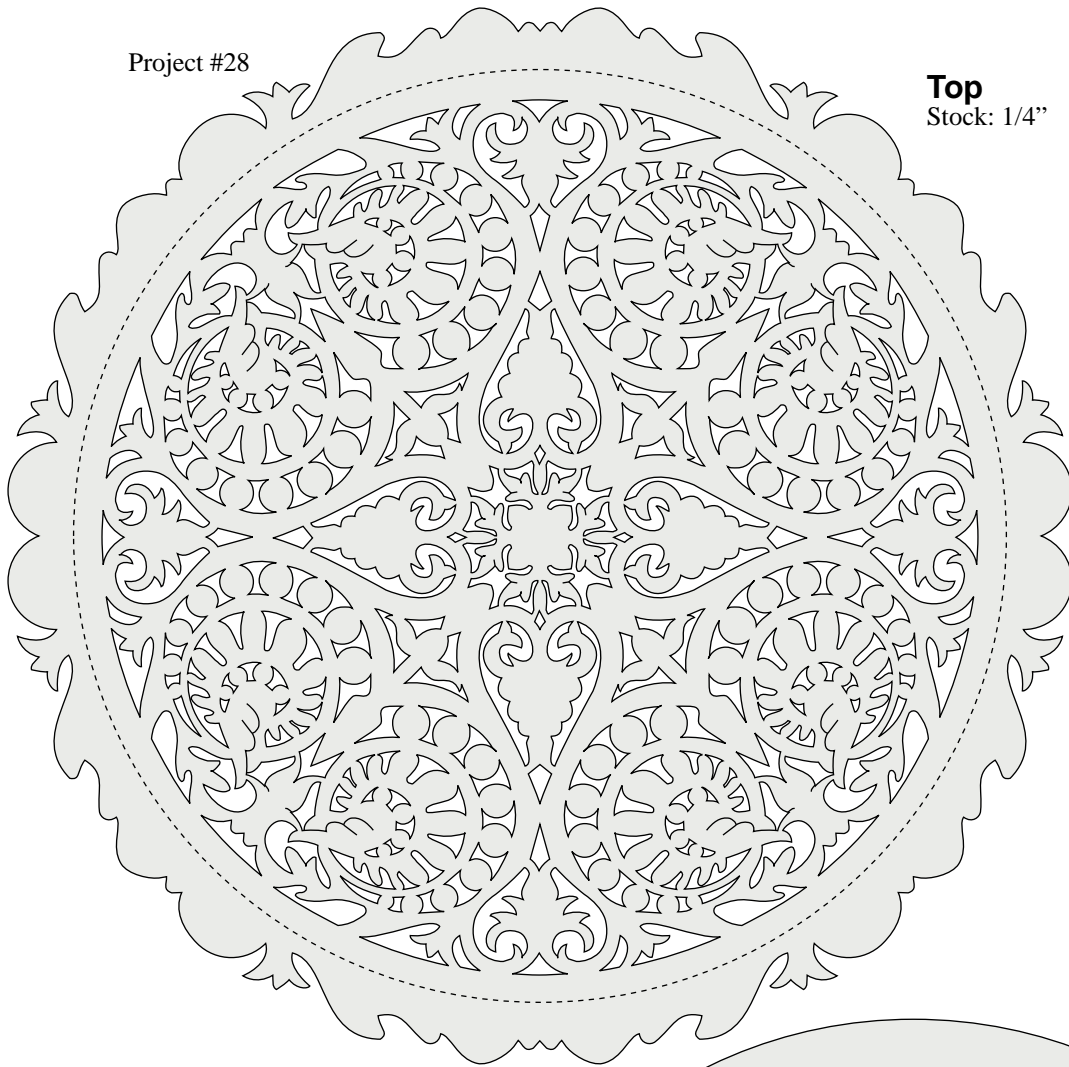

Frame
Stock: 1 1/2"

Circle indicates
position of key and
turntable shafts.



Cut out for music box

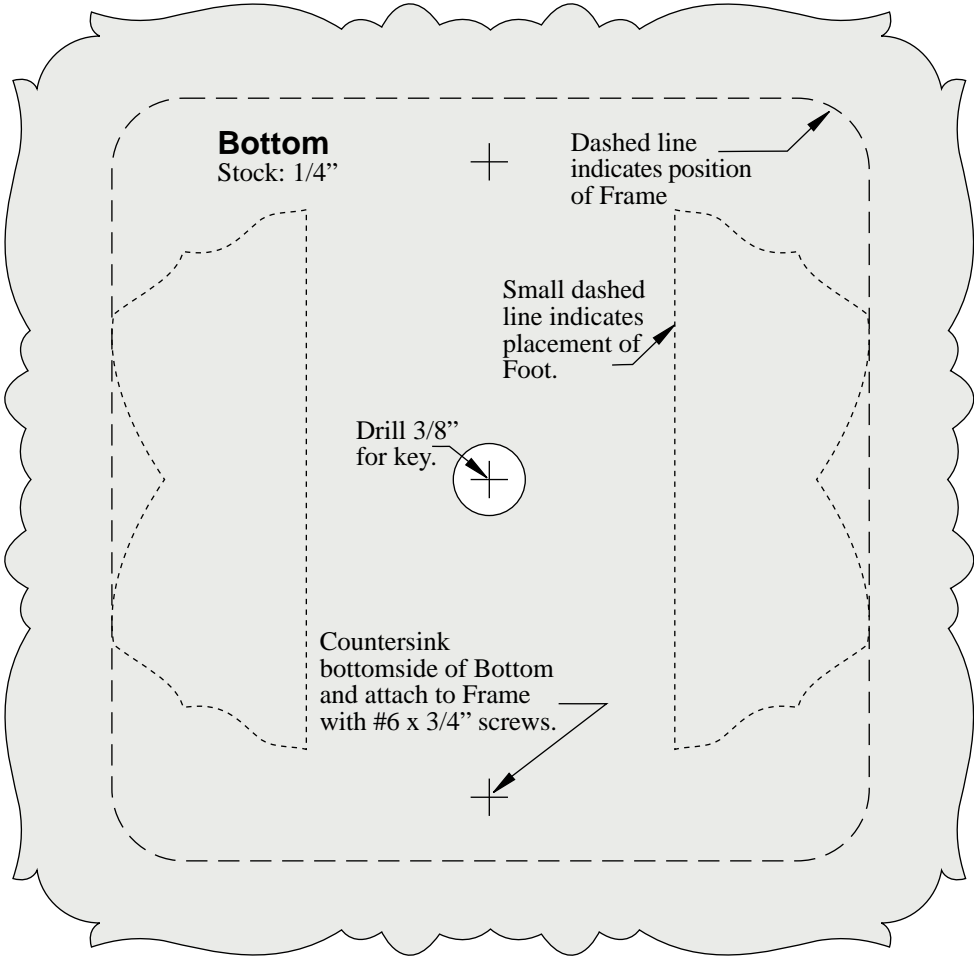
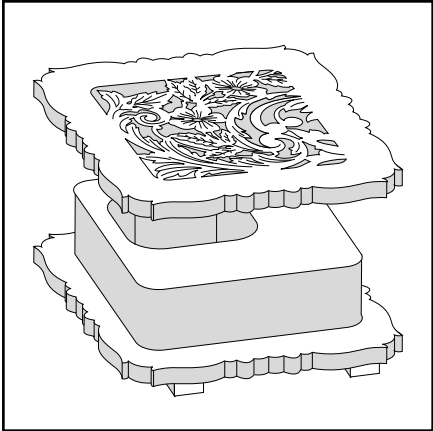
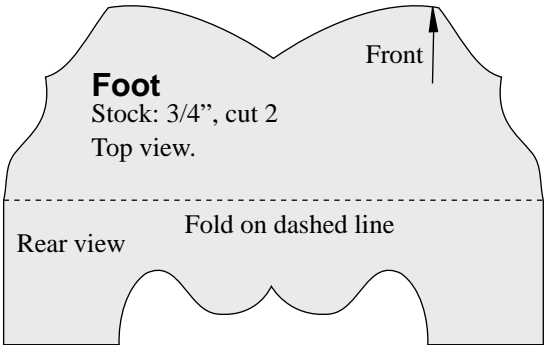

Project #29

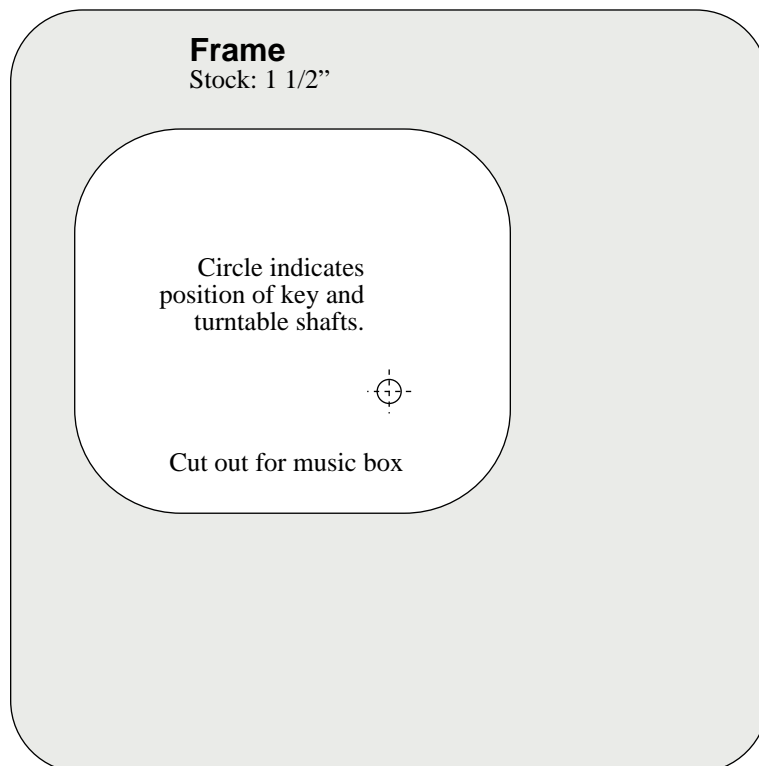

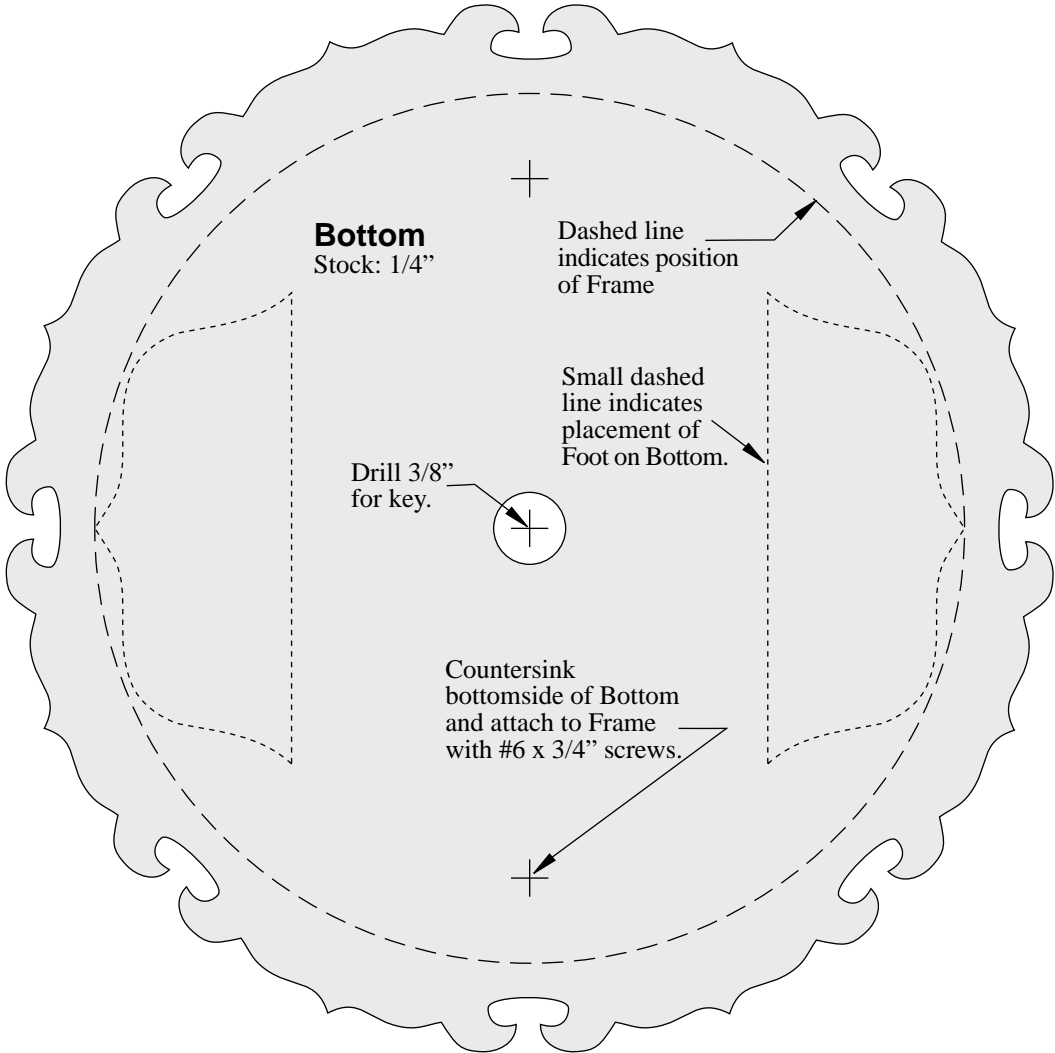
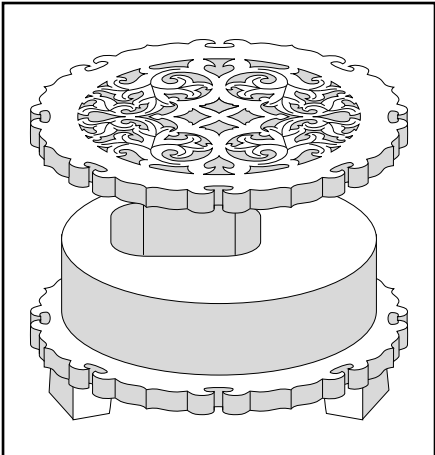
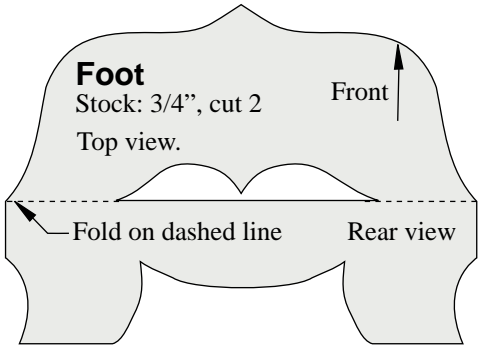

Project #30

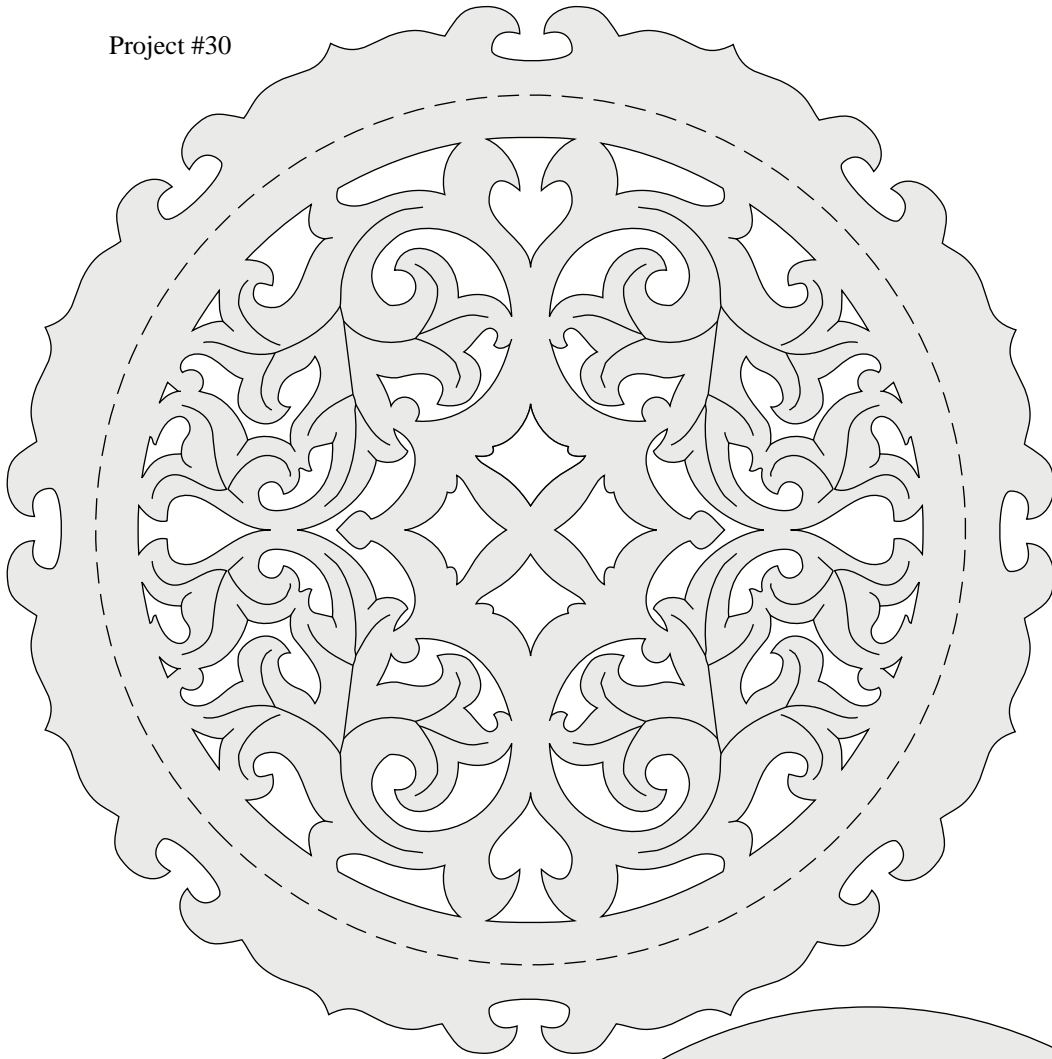

Top
Stock: 1/4"

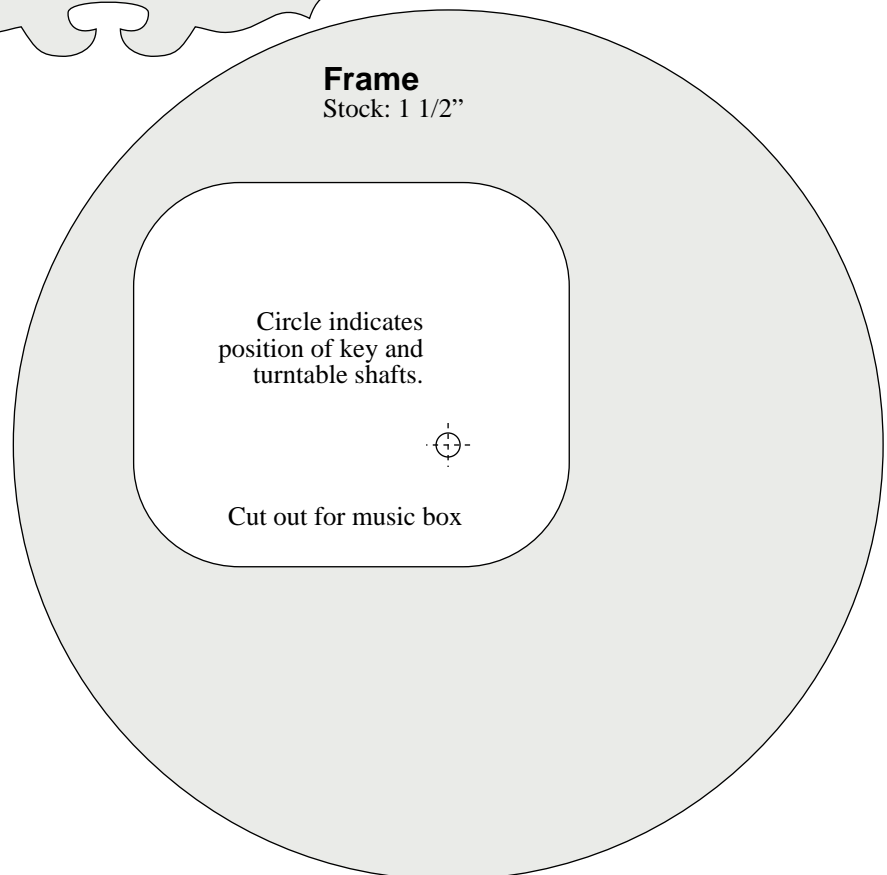

Frame
Stock: 1 1/2"

Circle indicates
position of key and
turntable shafts.



Cut out for music box

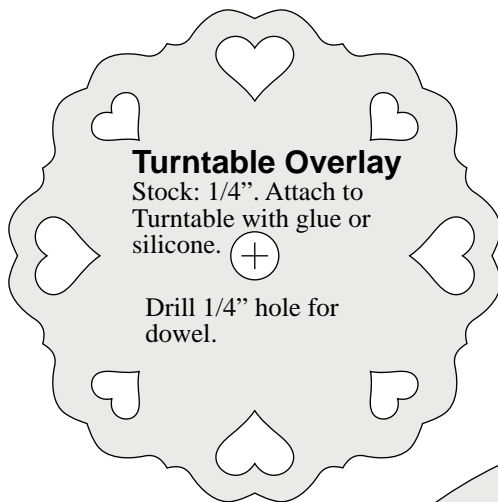
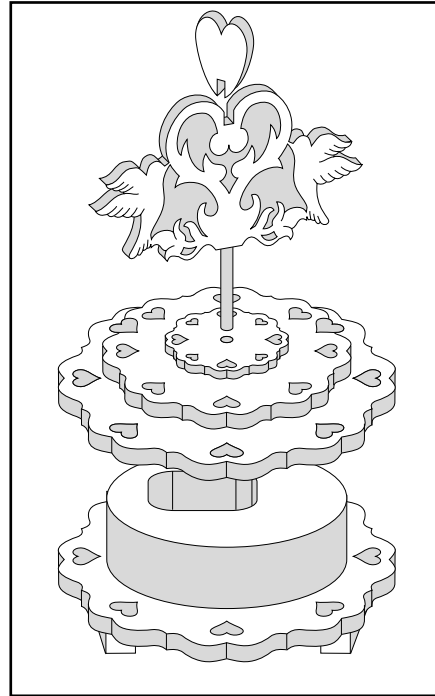

Turntable Overlay

Stock: 1/4". Attach to Turntable with glue or silicone.



Drill 1/4" hole for dowel.

Frame

Stock: 1 1/2"

Circle indicates position of key and turntable shafts.



Cut out for music box

Project #31

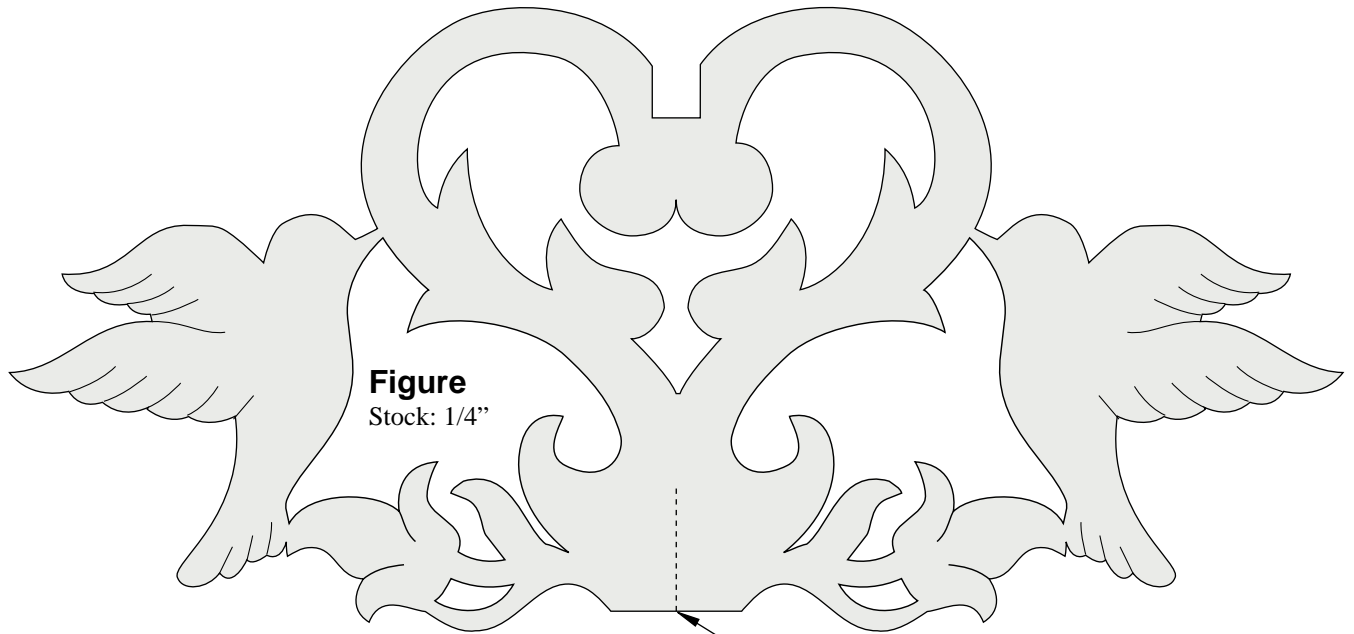
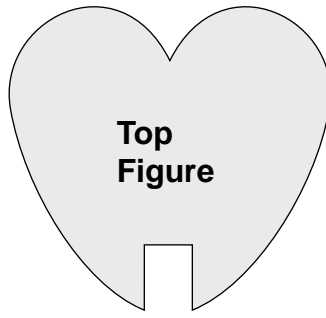

Drill for a 1/4"D x 3 1/2" long dowel.
Secure in Figure and Turntable with glue.

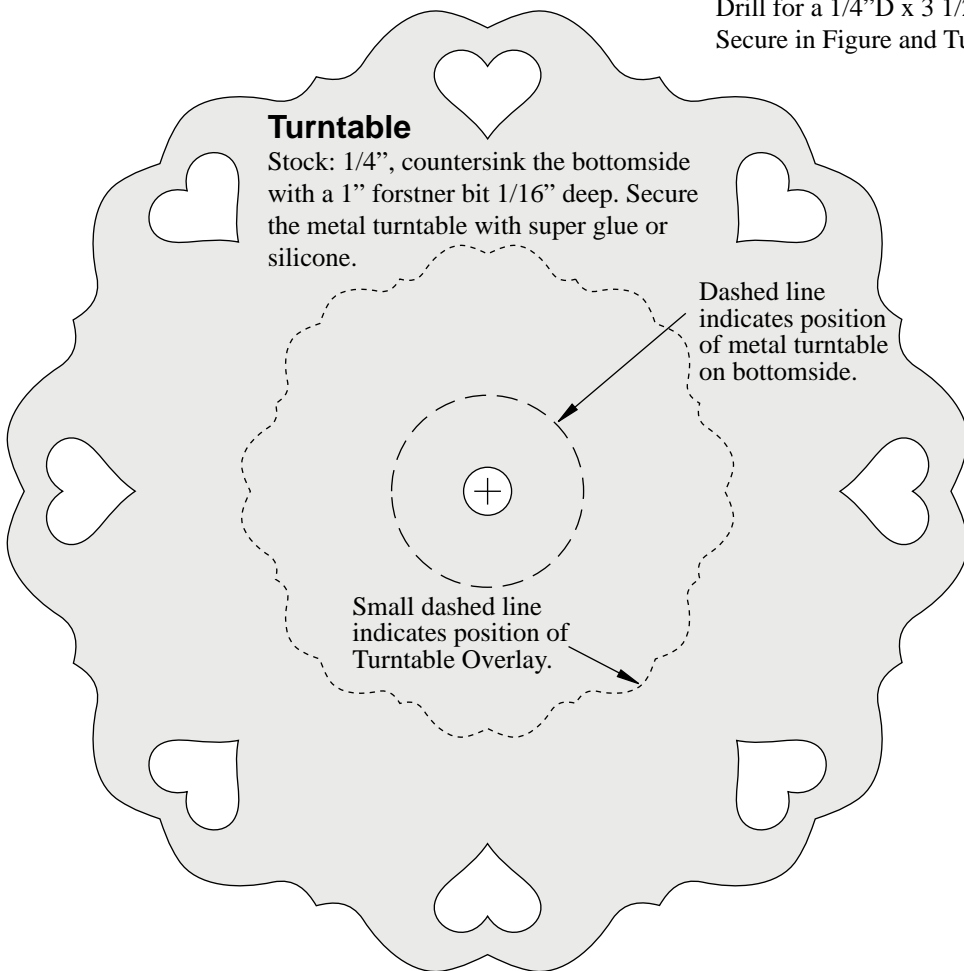

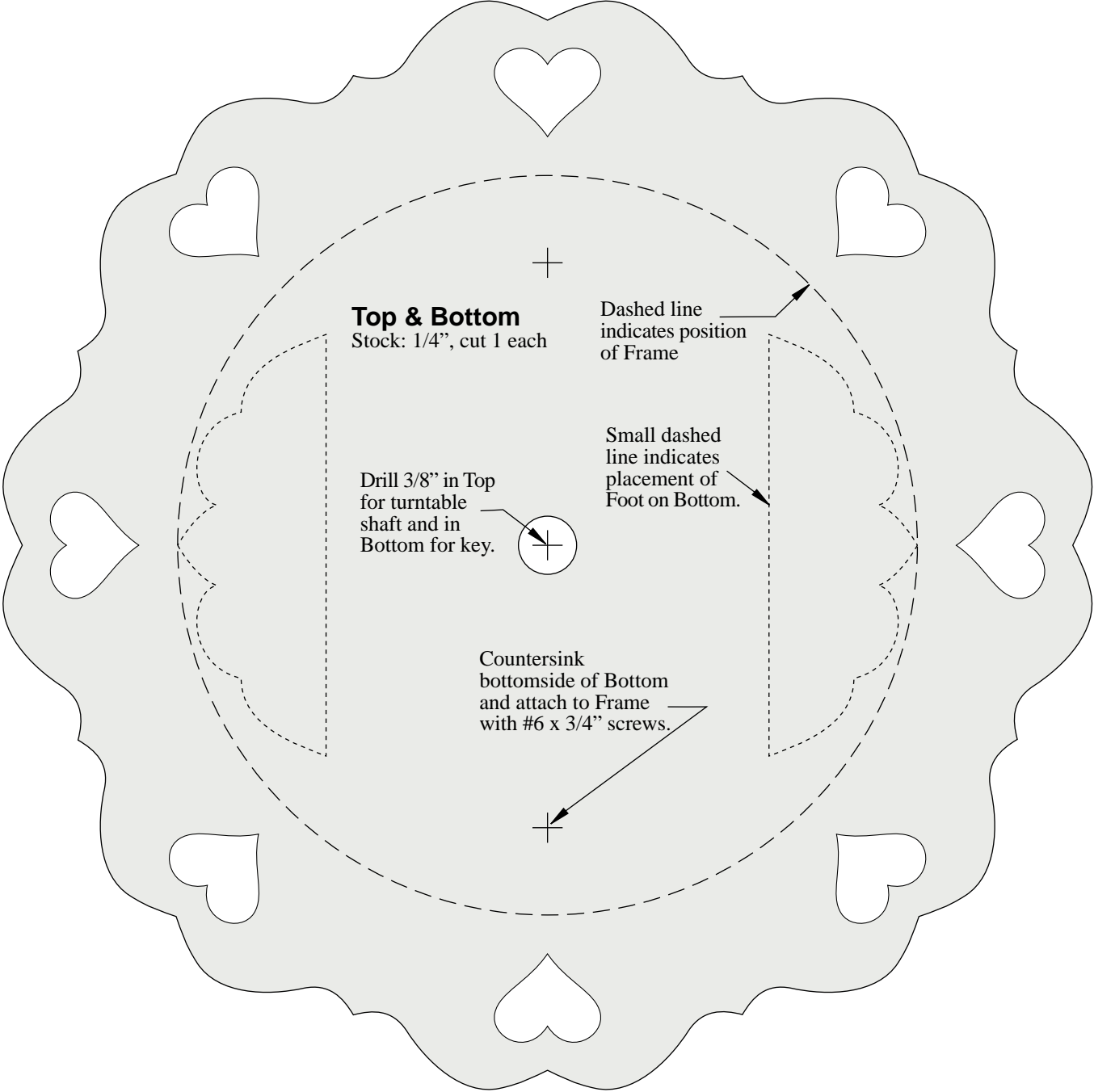
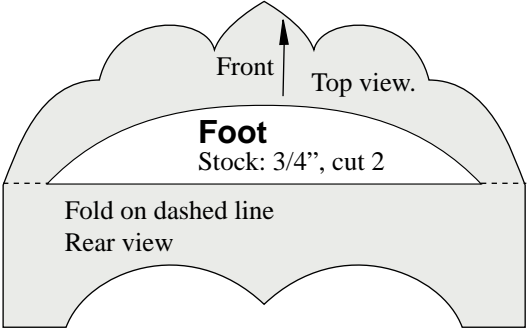

Project #32

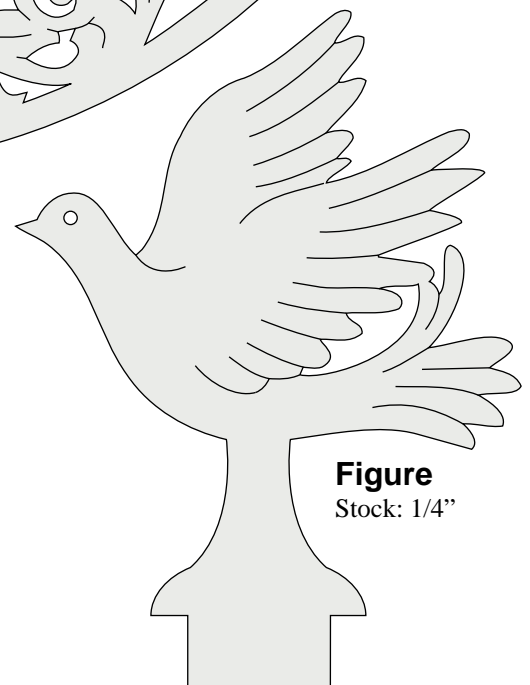
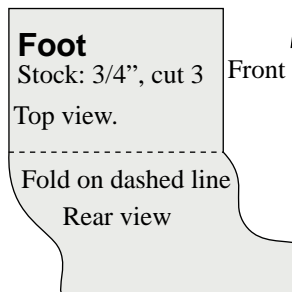
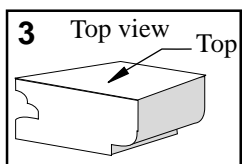
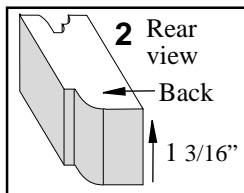
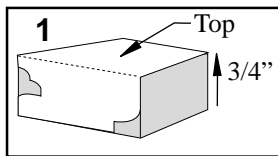
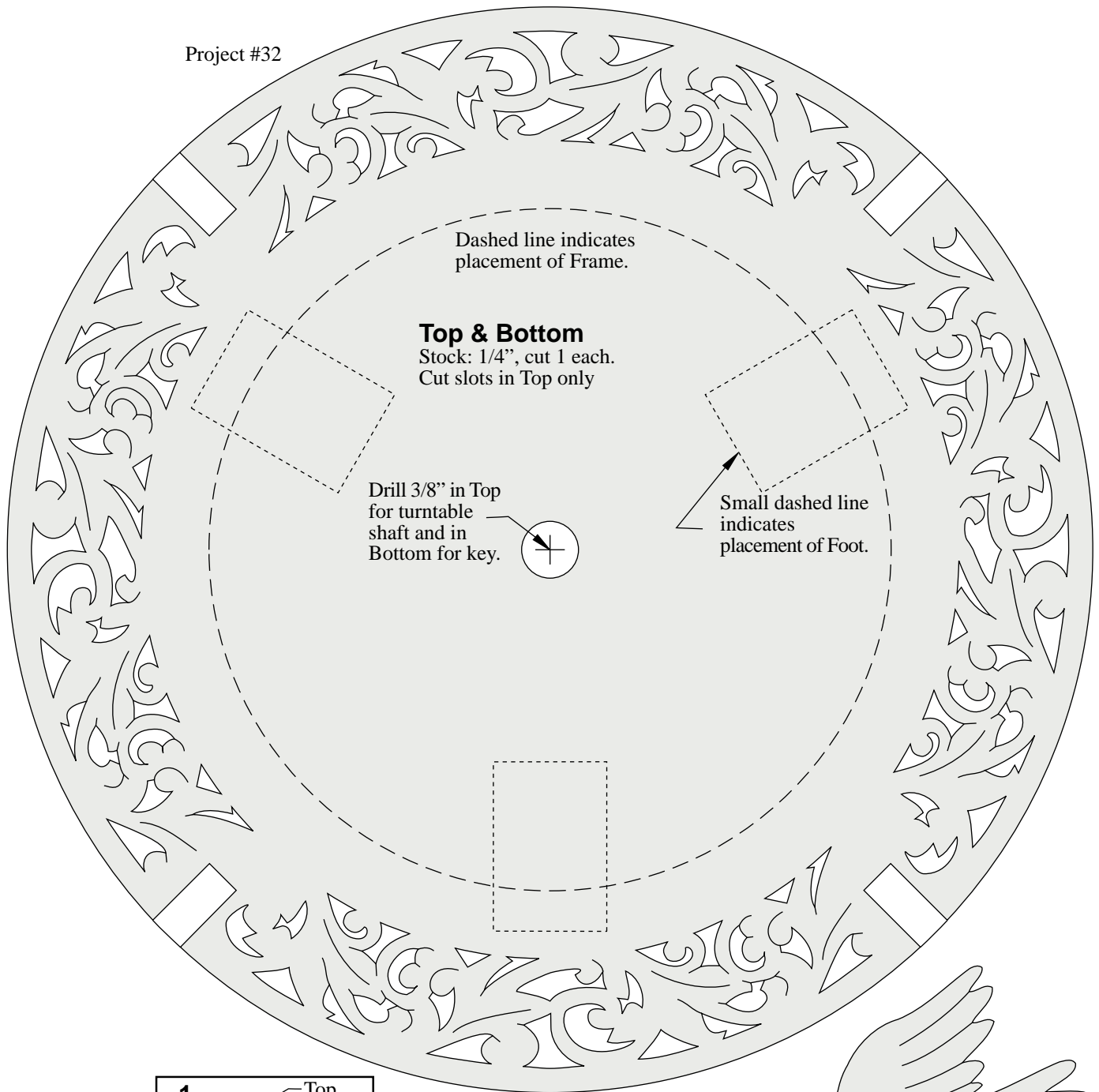

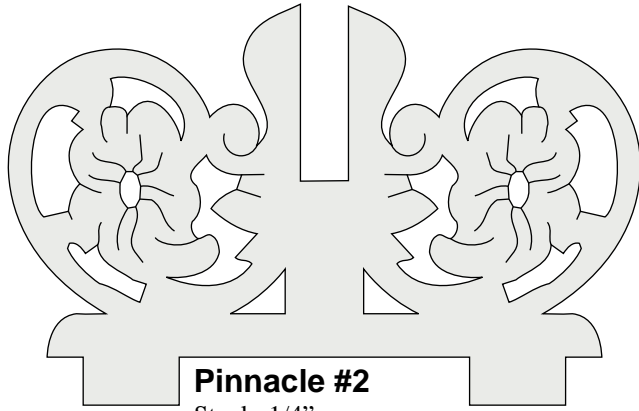

Pinnacle #2
Stock: 1/4"

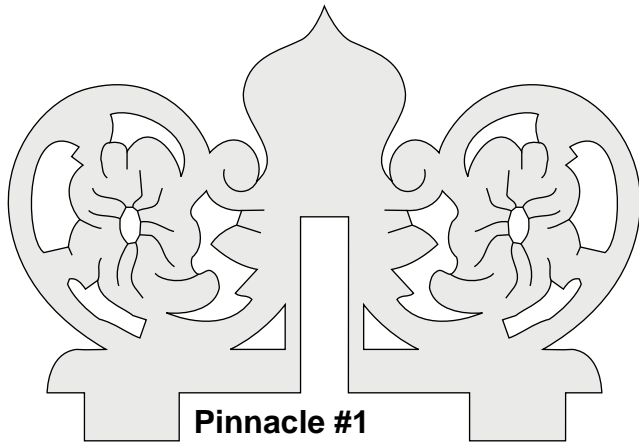

Pinnacle #1
Stock: 1/4"

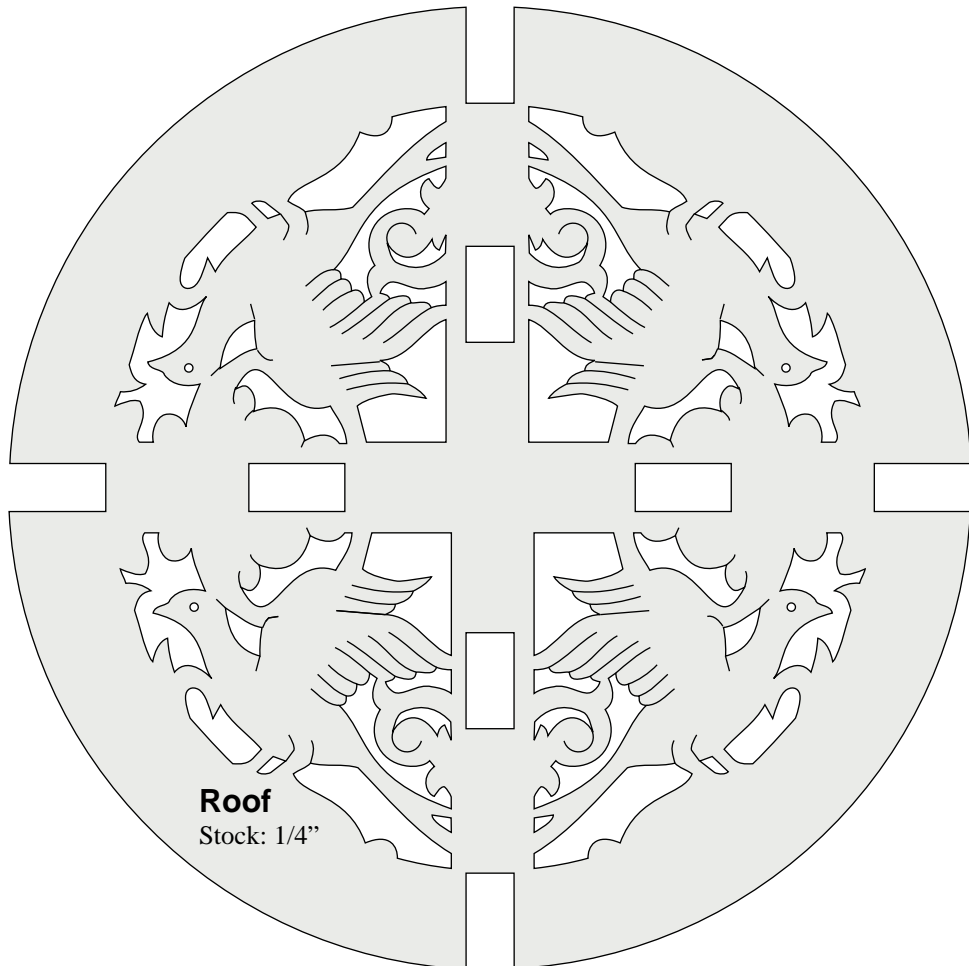
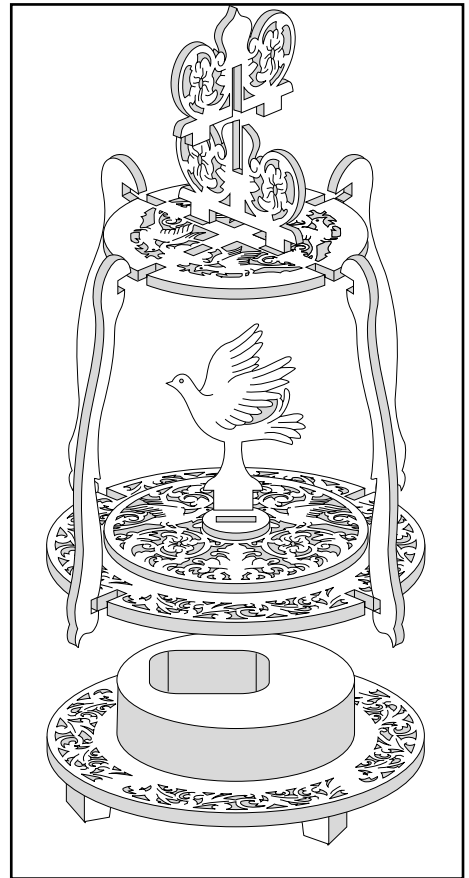

Roof
Stock: 1/4"

Project #32

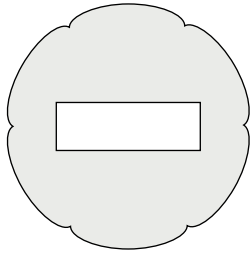

Turntable Overlay
Stock: 3/8"

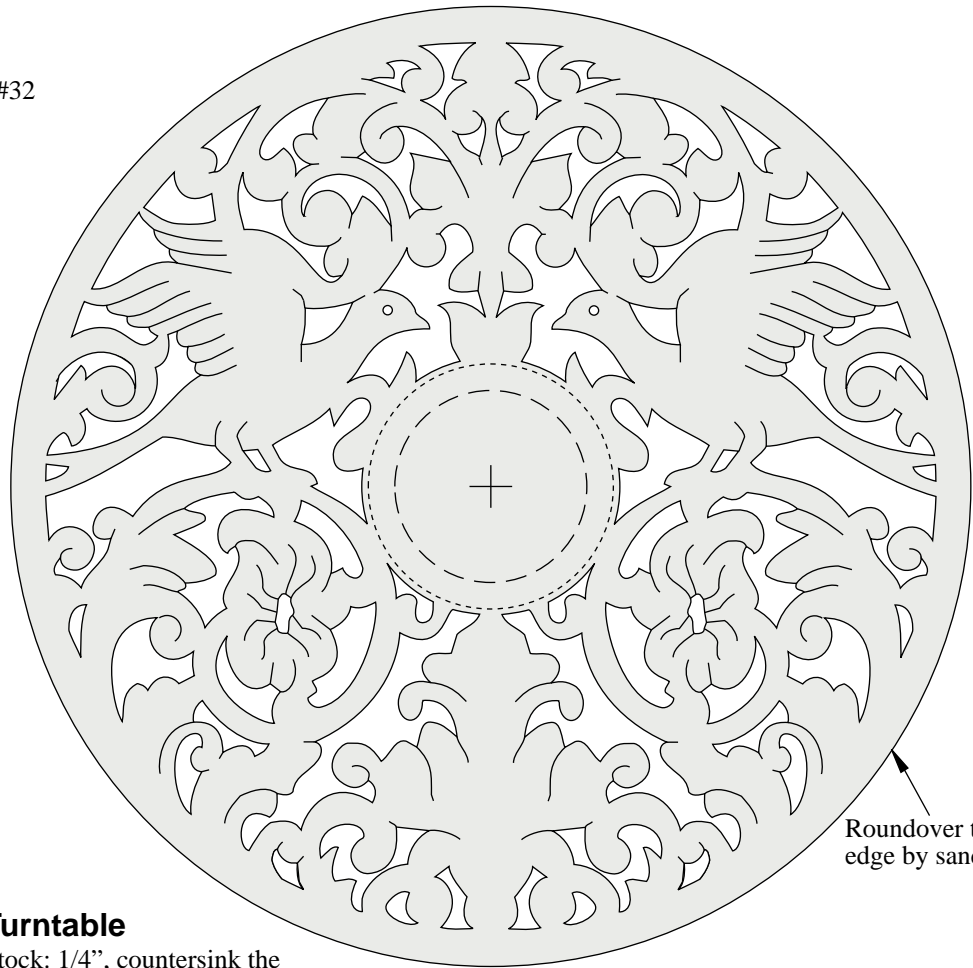

Turntable

Stock: 1/4", countersink the bottomside with a 1" forstner bit 1/16" deep. Secure the metal turntable with super glue or silicone.

Dashed line indicates position of metal turntable on bottomside. Small dashed line indicates placement of Turntable Overlay.

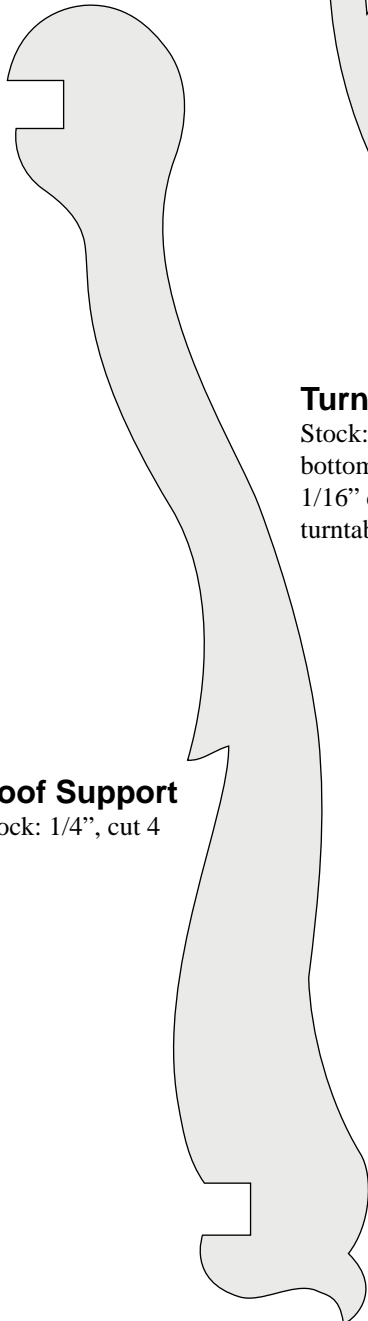

Roof Support
Stock: 1/4", cut 4

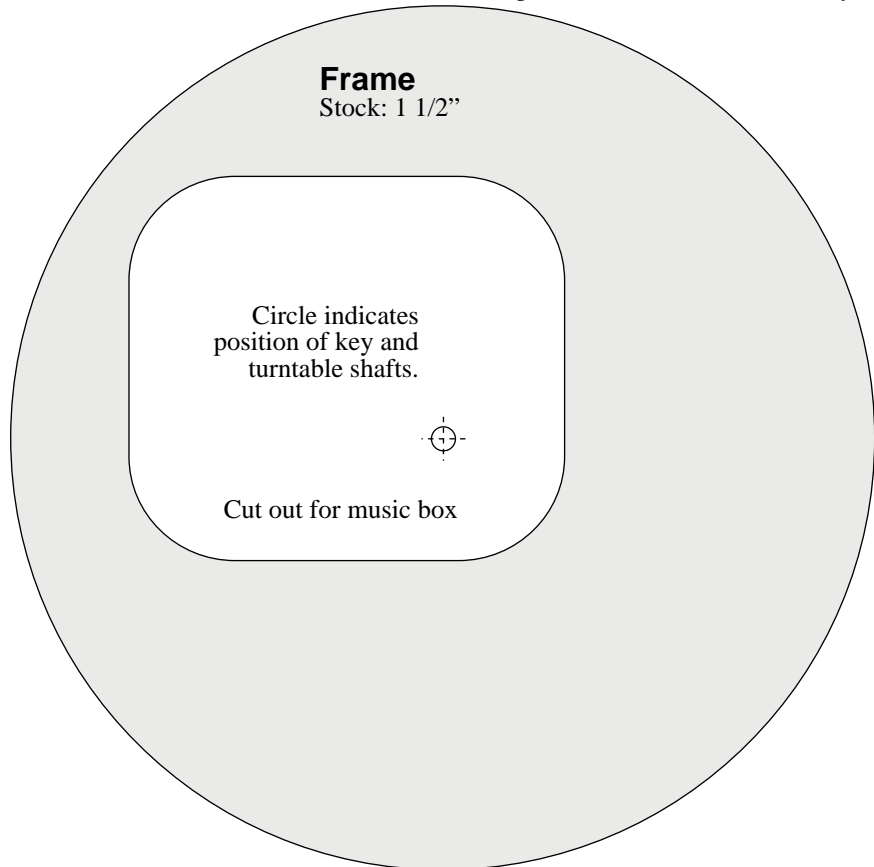

Frame
Stock: 1 1/2"

Circle indicates position of key and turntable shafts.

Cut out for music box

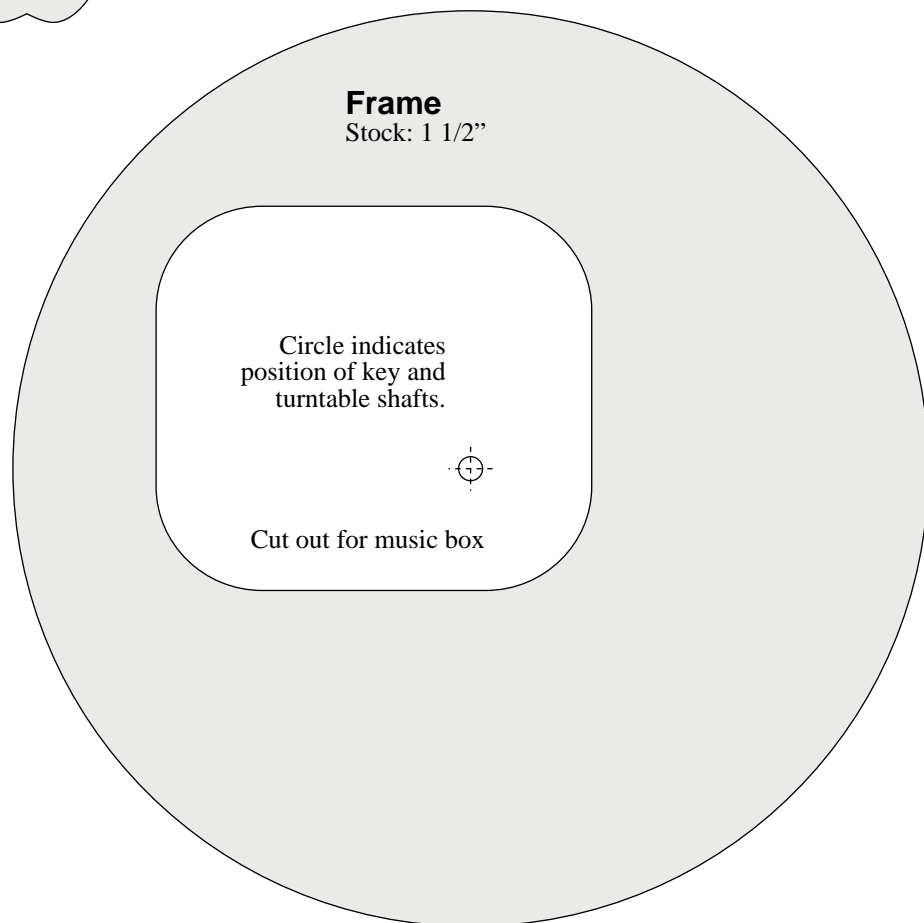
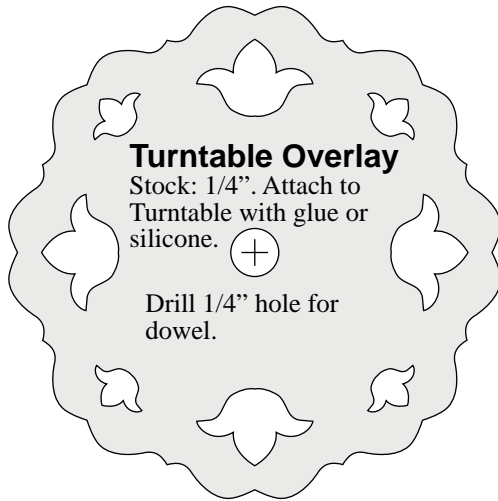
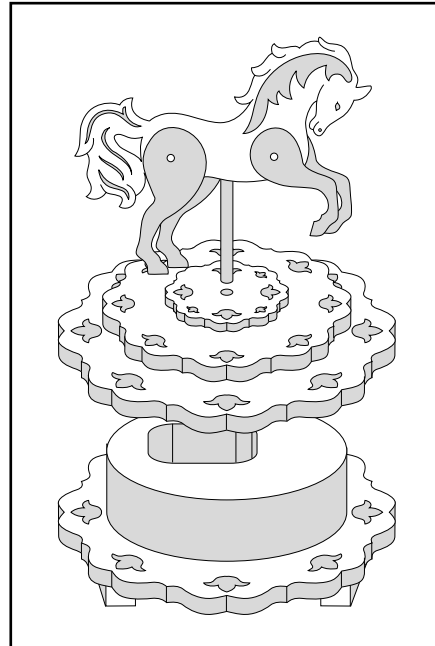

Project #33

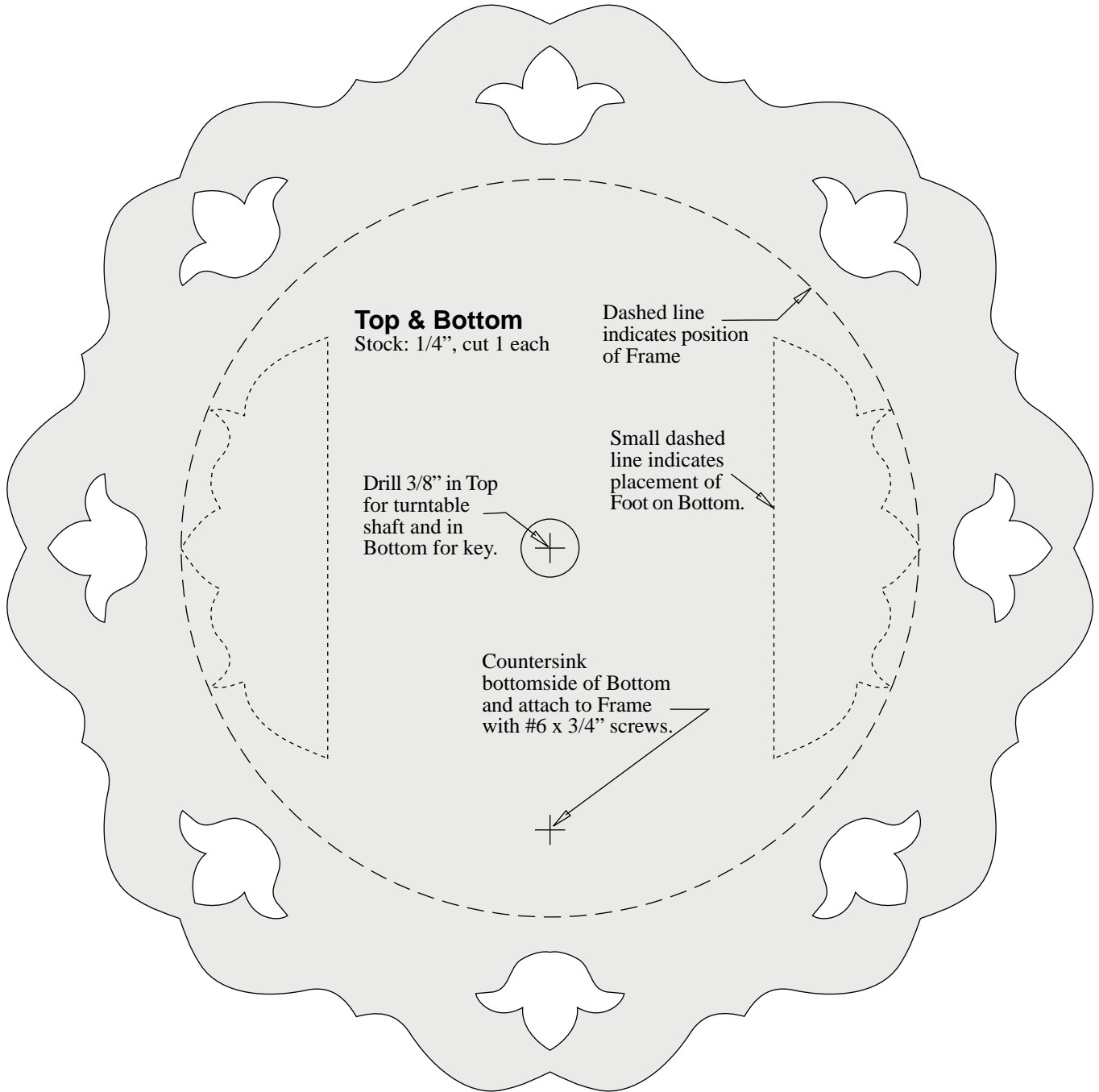
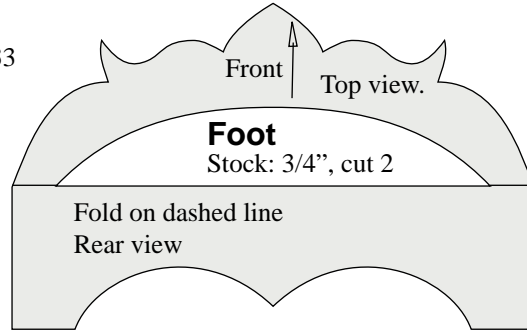

Project #33

Body

Stock: 3/8"

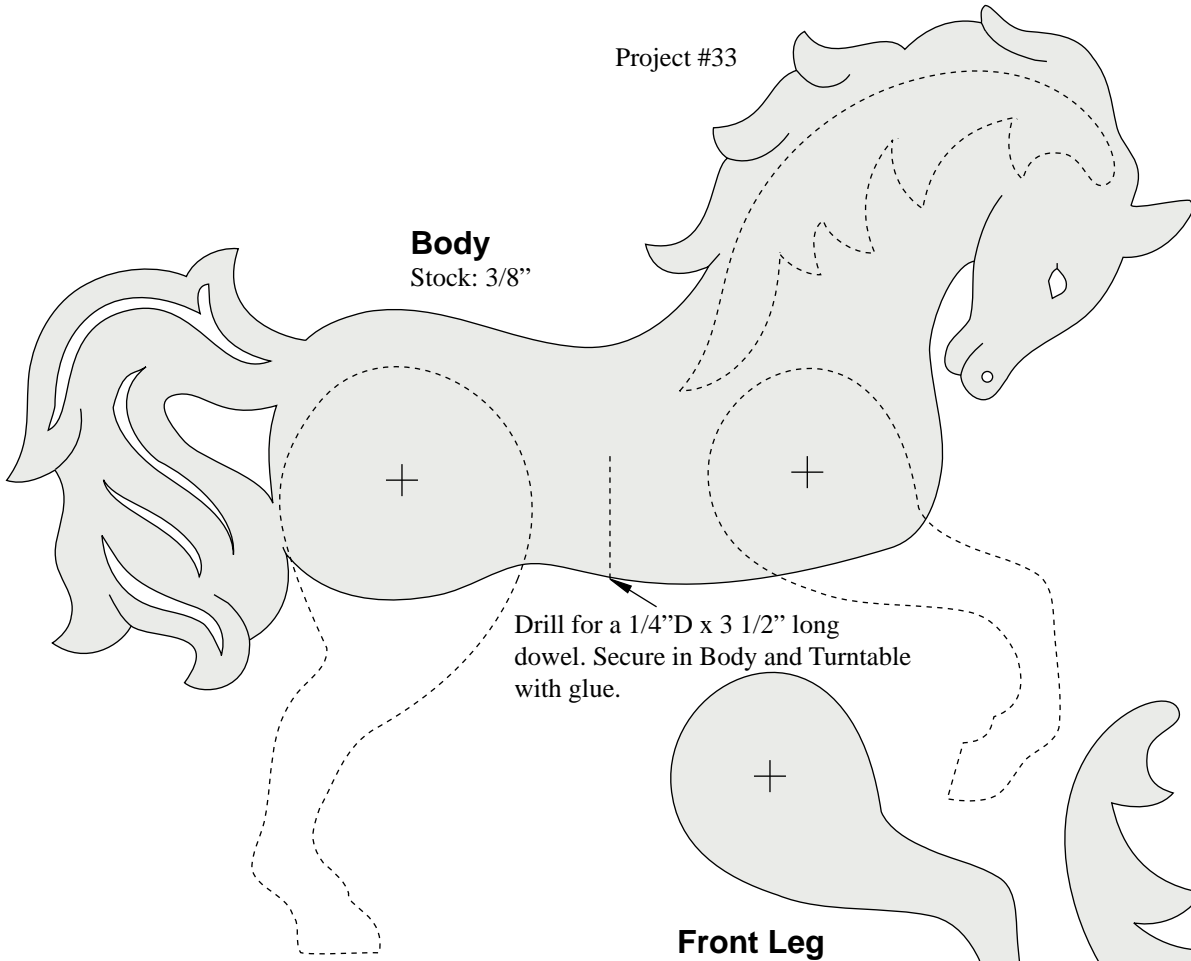

Drill for a 1/4"D x 3 1/2" long dowel. Secure in Body and Turntable with glue.

Front Leg

Stock: 1/8" - 1/4", cut 2

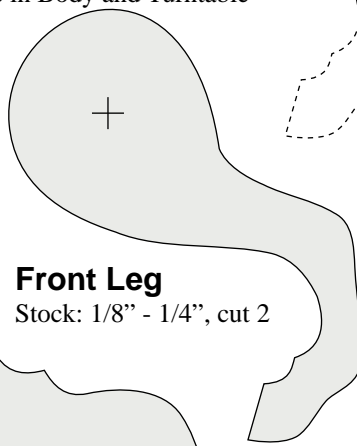

Mane

Stock: 1/16" - 1/8", cut 2.
Attach with glue or silicone.

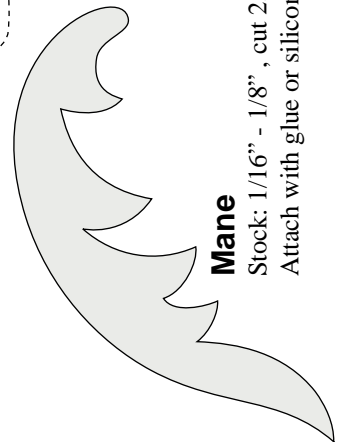

Turntable

Stock: 1/4", countersink the bottomside with a 1" forstner bit 1/16" deep. Secure the metal turntable with super glue or silicone.

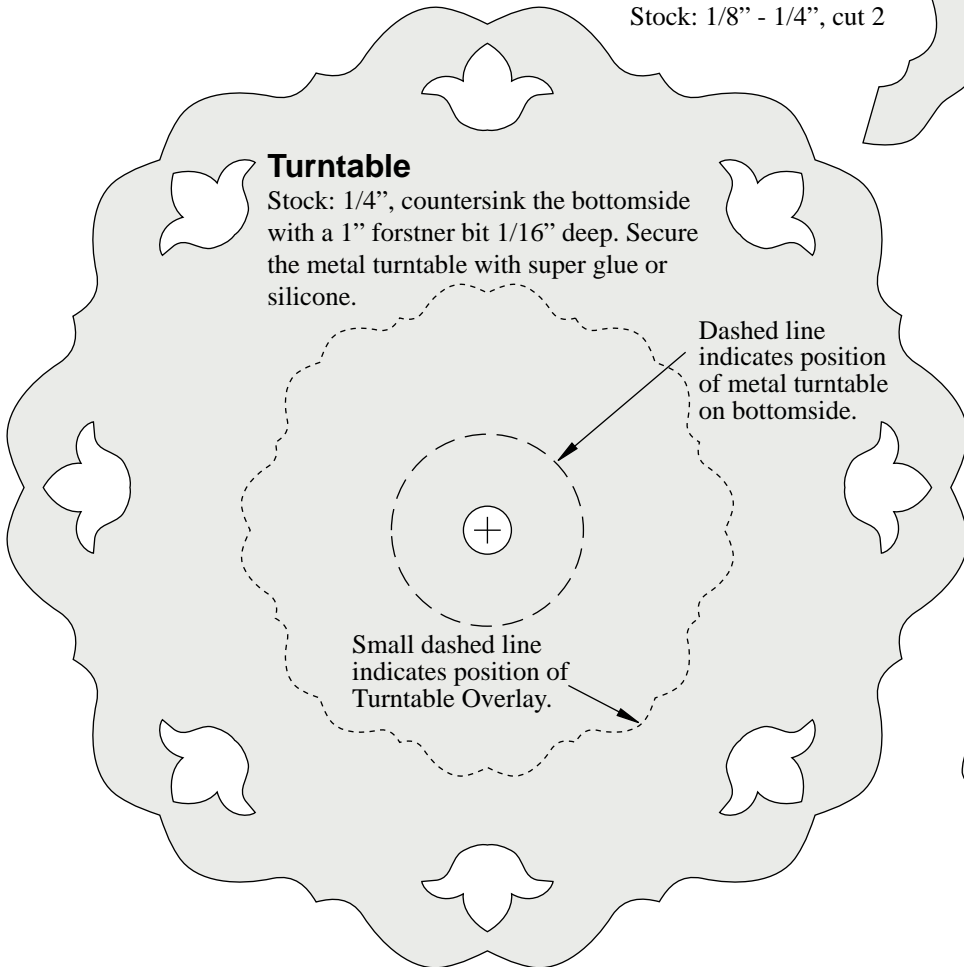

Dashed line indicates position of metal turntable on bottomside.

Small dashed line indicates position of Turntable Overlay.

Back Leg

Stock: 1/8" - 1/4", cut 2

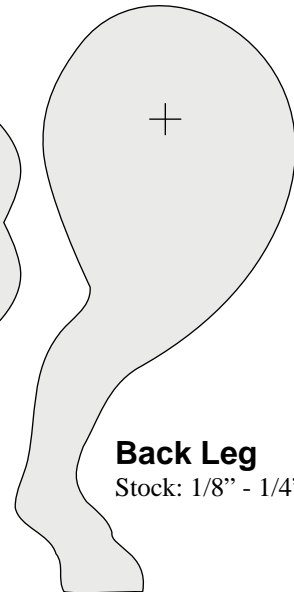

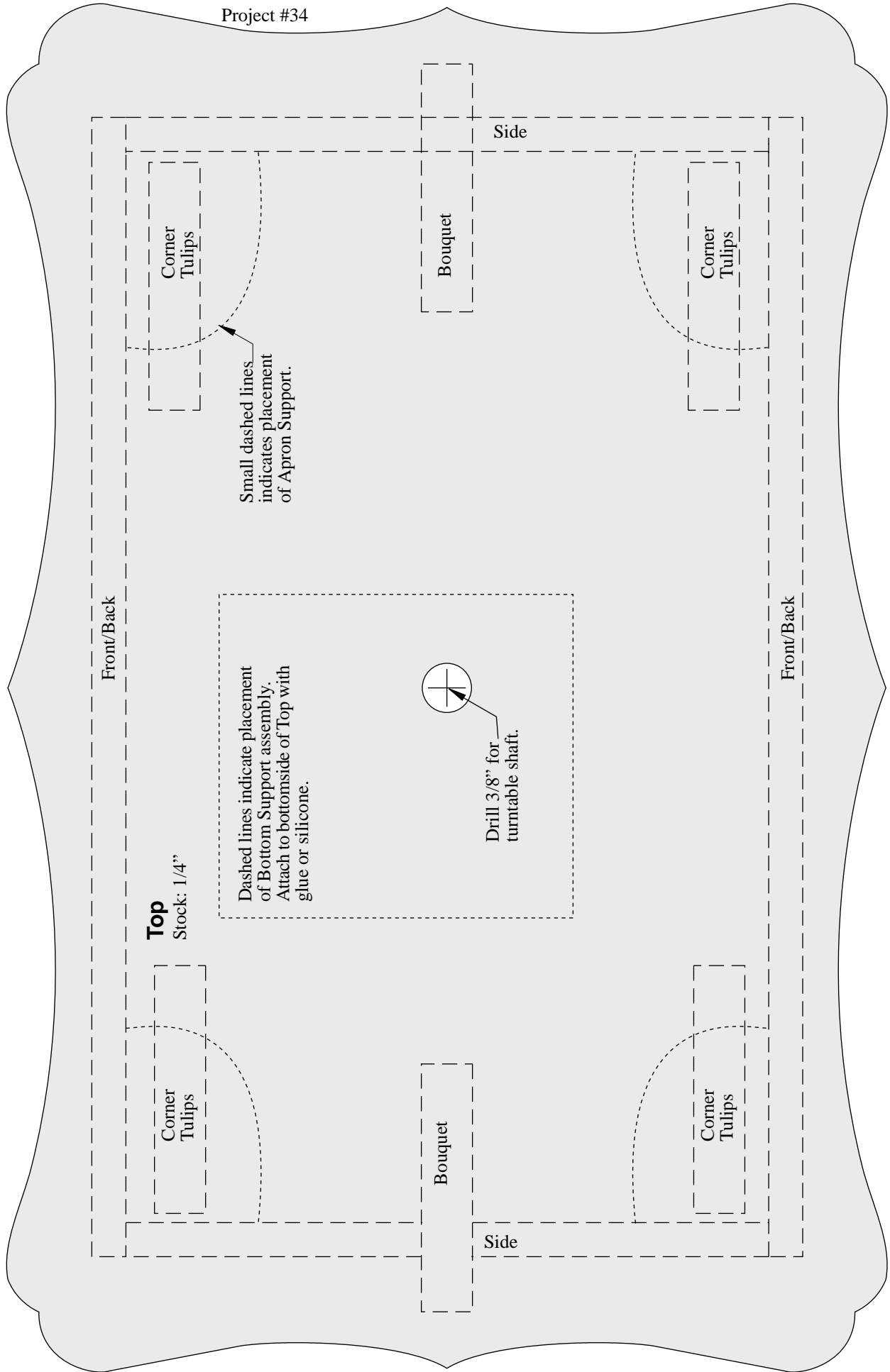

Turntable Overlay

Stock: 1/4", Secure to the Turntable with glue or silicone.

Adjust slot if necessary for thickness of material used.

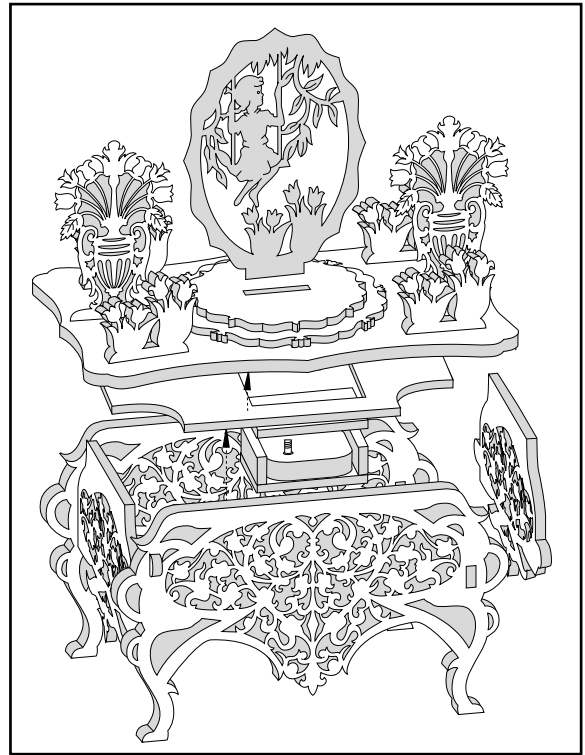

Turntable

Stock: 1/4", countersink the bottomside with a 1" forstner bit 1/16" deep. Secure the metal turntable with super glue or silicone.

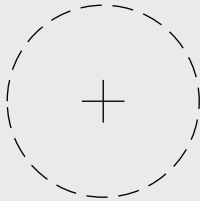

Dashed line indicates placement of Turntable Overlay.

Corner Tulips

Stock: 3/8", Cut 4.

Secure to Top with glue or silicone.

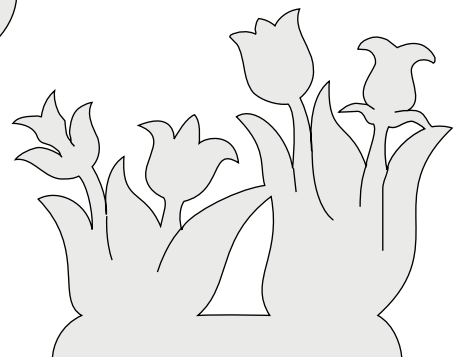

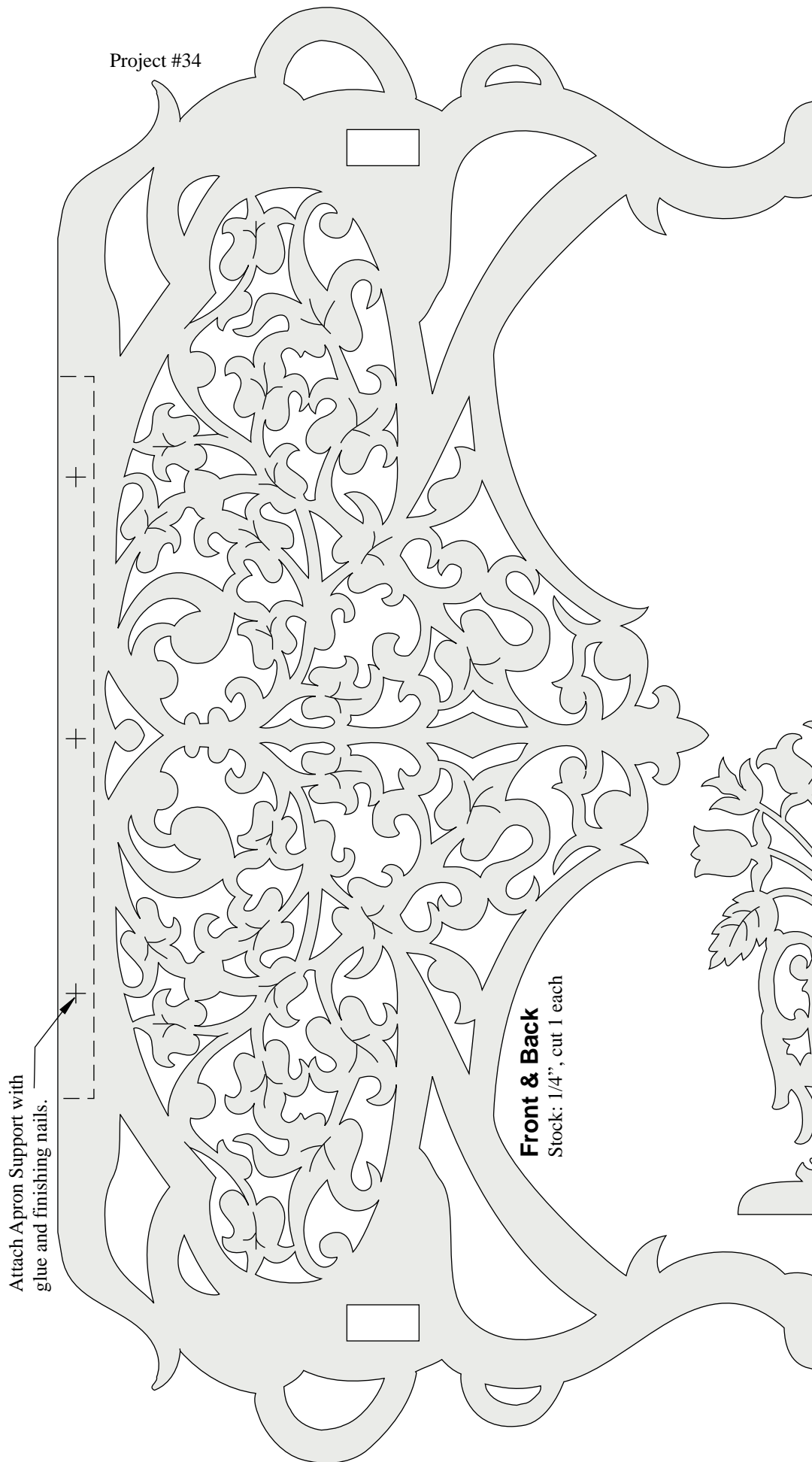

Front & Back
Stock: 1/4", cut 1 each

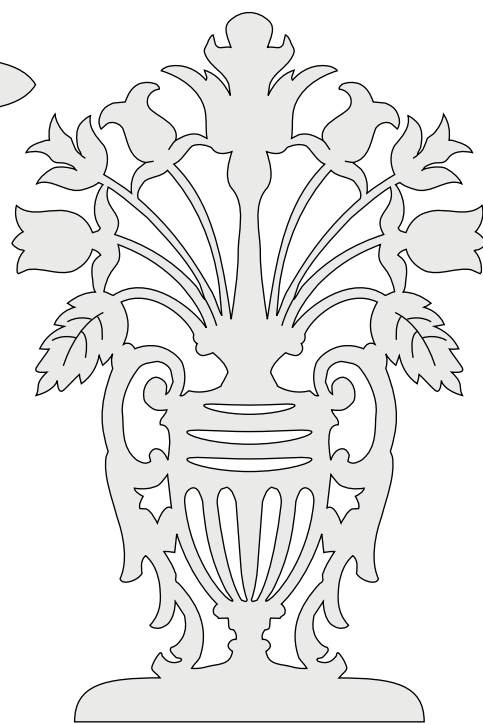

Bouquet
Stock: 3/8", cut 2

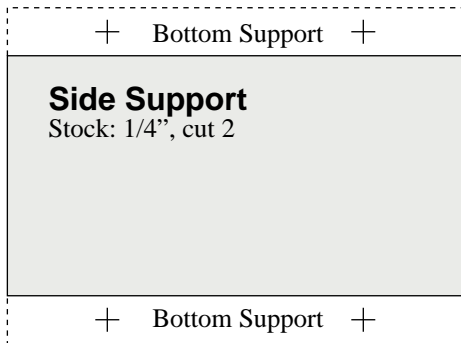
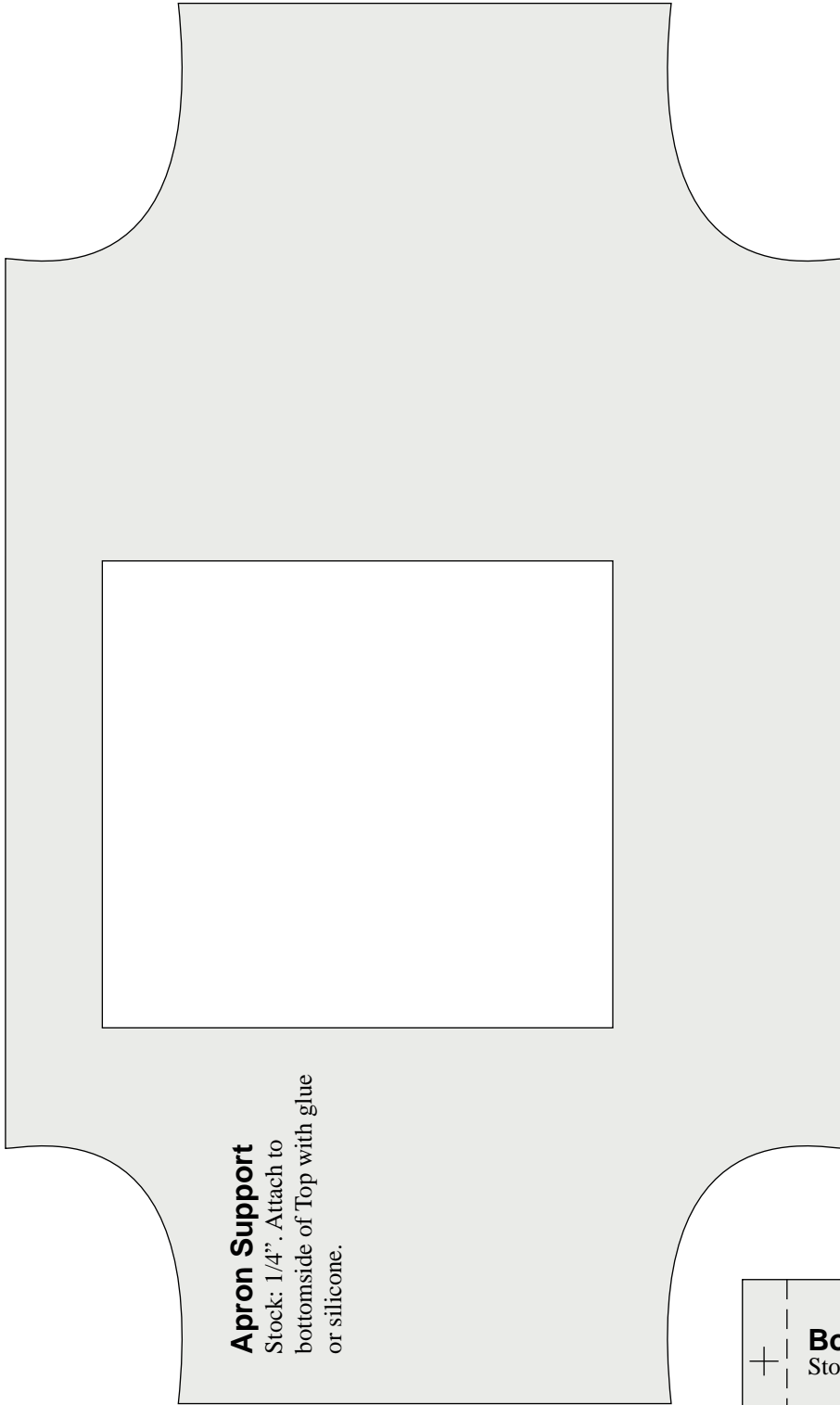

Assembly Instructions

Assemble by first attaching the Sides to the Front and Back. Next attach the Apron Support. Now attach the Bottom Supports to the Side Supports. Insert the music box movement and secure in place with silicone. Attach the Leg assembly to the bottom of the Top and secure with glue or silicone. Insert the music box movement assembly into position on the underside of the Top and glue in place. Secure the Turntable Overlay to the Turntable and secure the figures into place. Then attach the wood Turntable to the metal turntable.

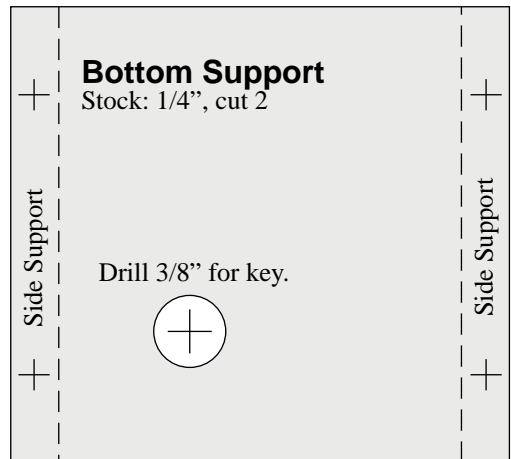

Project #34

Side

Stock: 1/4", cut 2

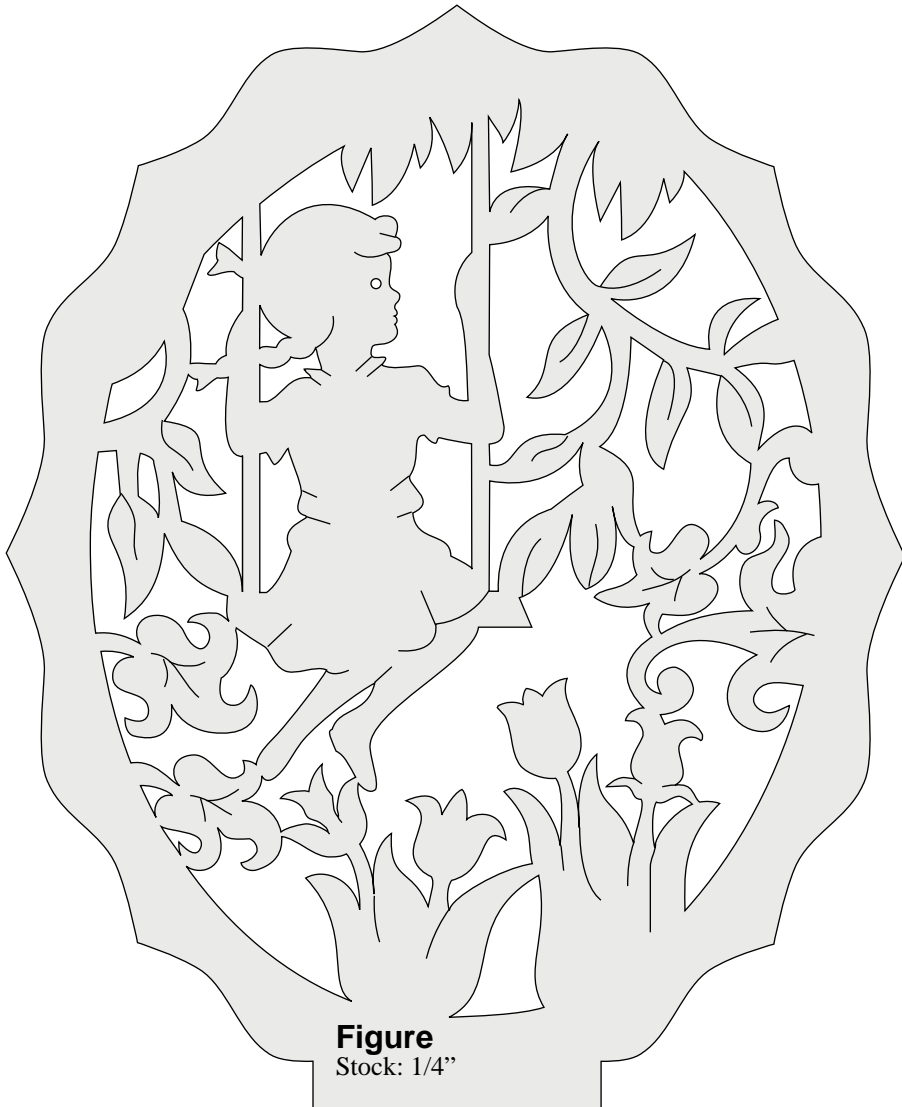
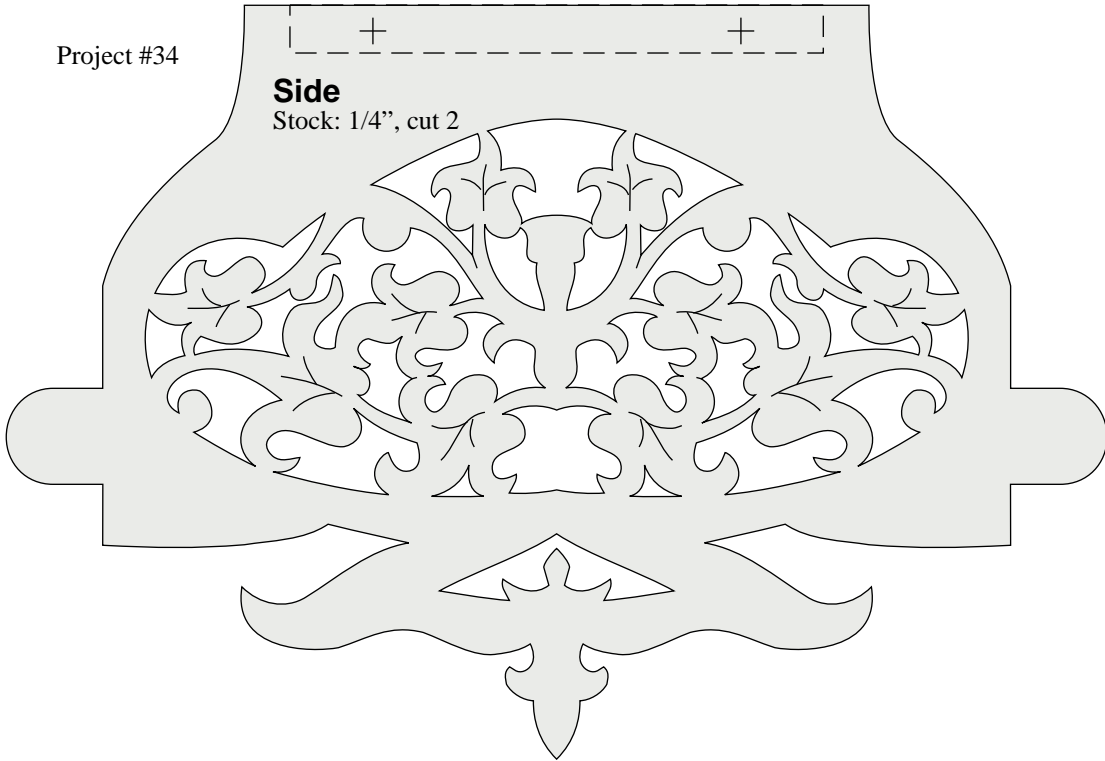

Figure

Stock: 1/4"

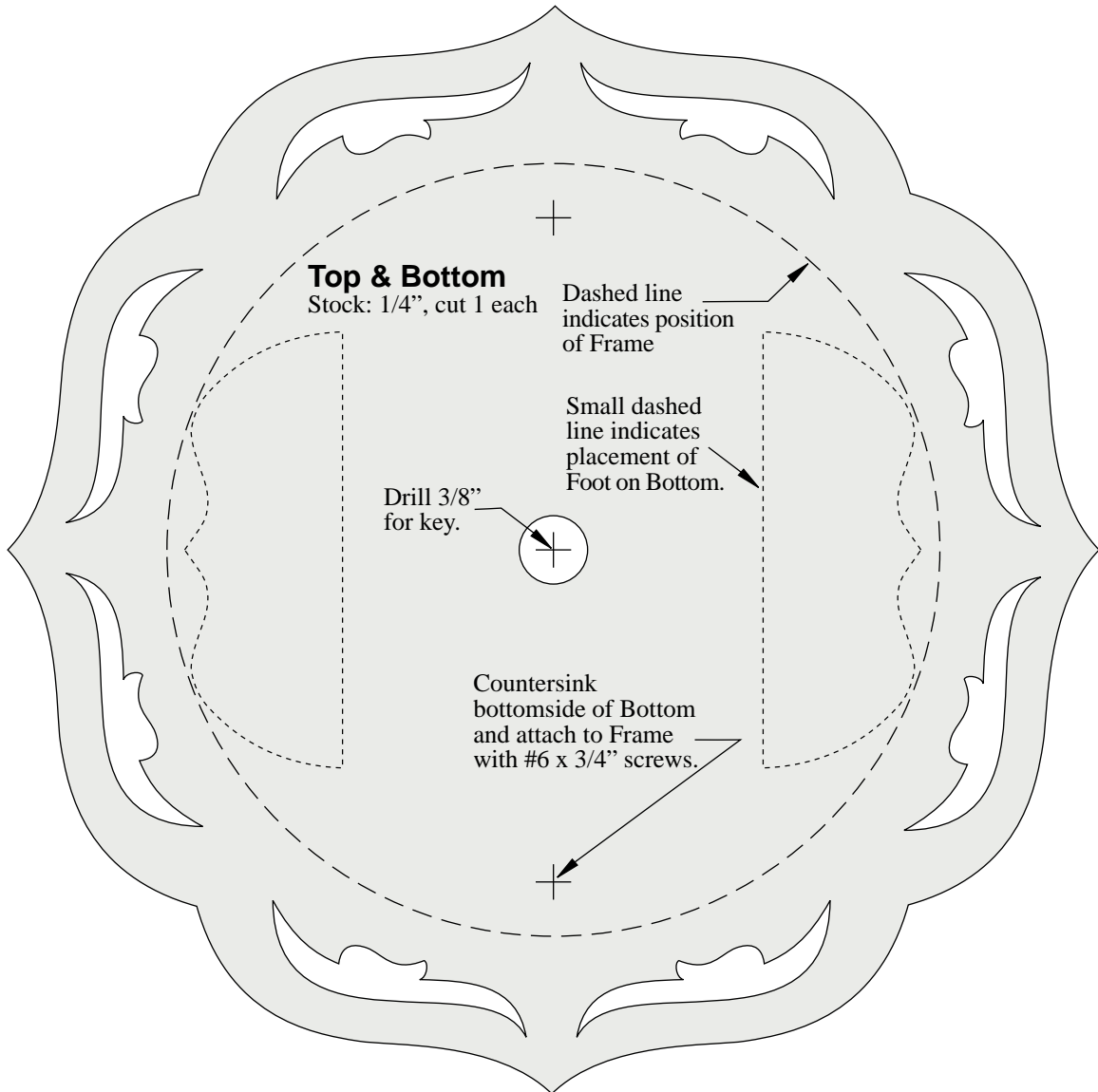
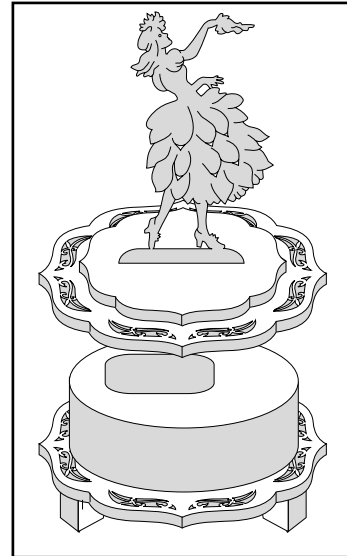
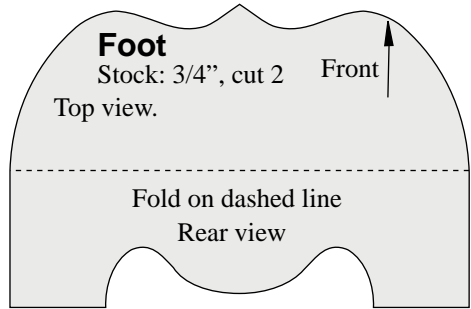

Project #35-58

Turntable

Stock: 1/4". Countersink the bottomside with a 1" forstner bit 1/16" deep. Secure the metal turntable with super glue or silicone.

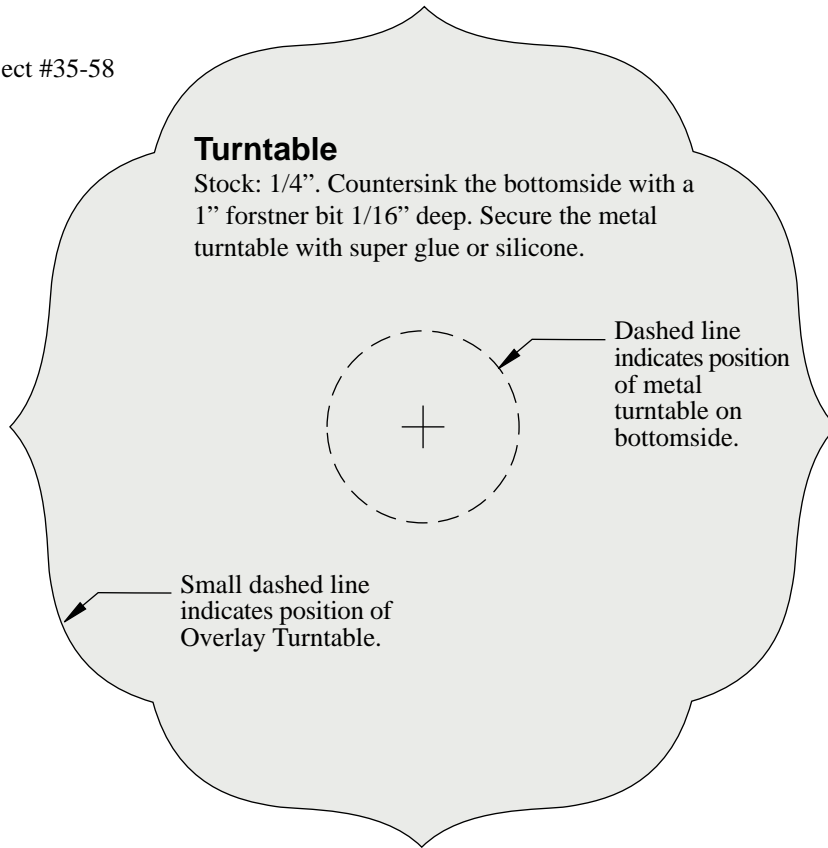

Frame

Stock: 1 1/2"

Circle indicates position of key and turntable shafts.



Cut out for music box

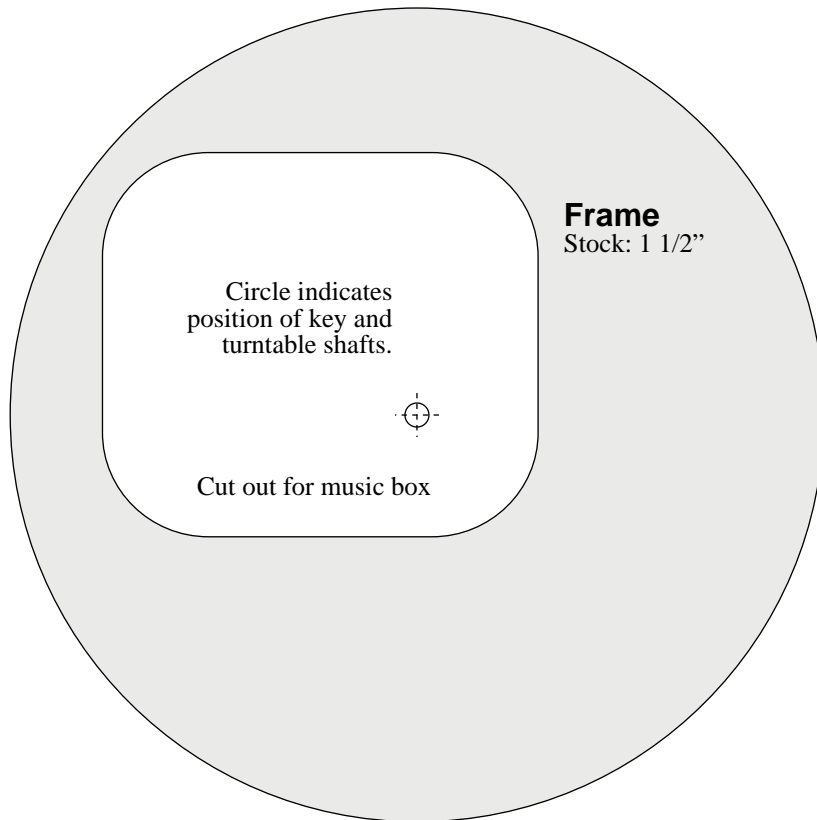

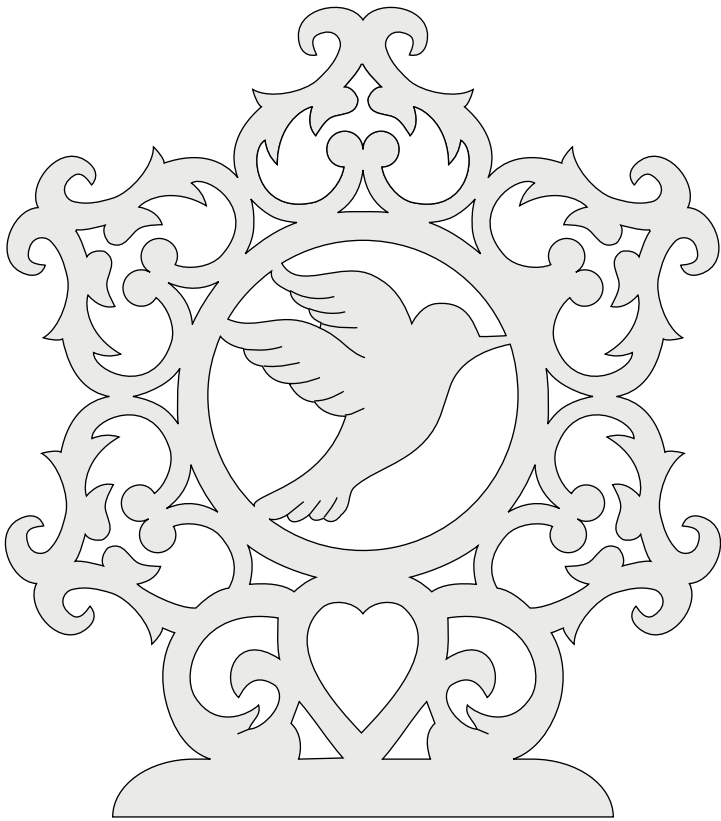

Bird & Hearts
Stock: 3/8"

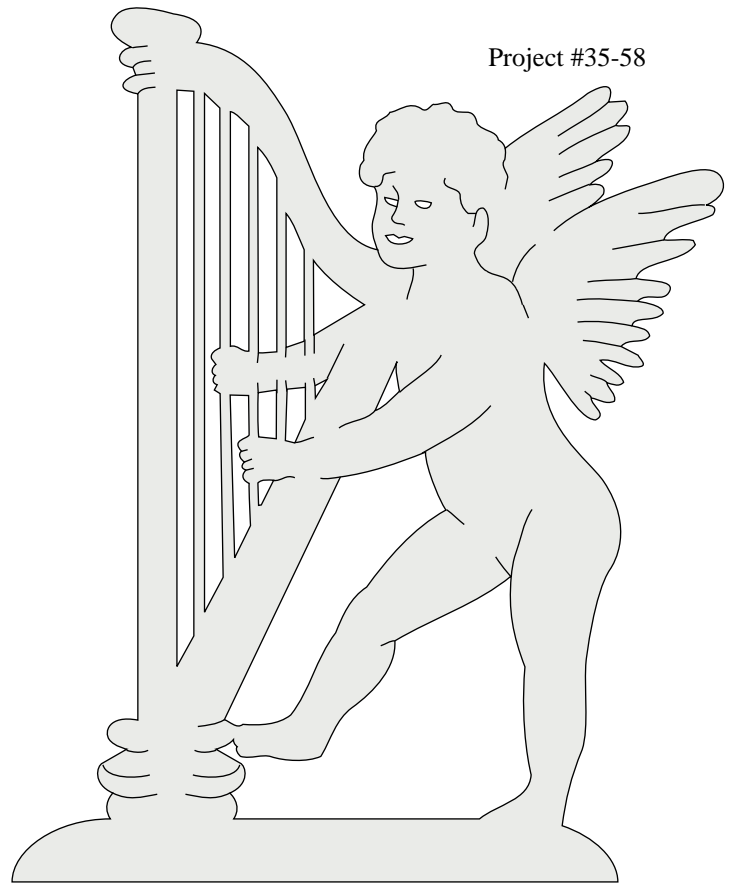

Cupid & Harp
Stock: 3/8"

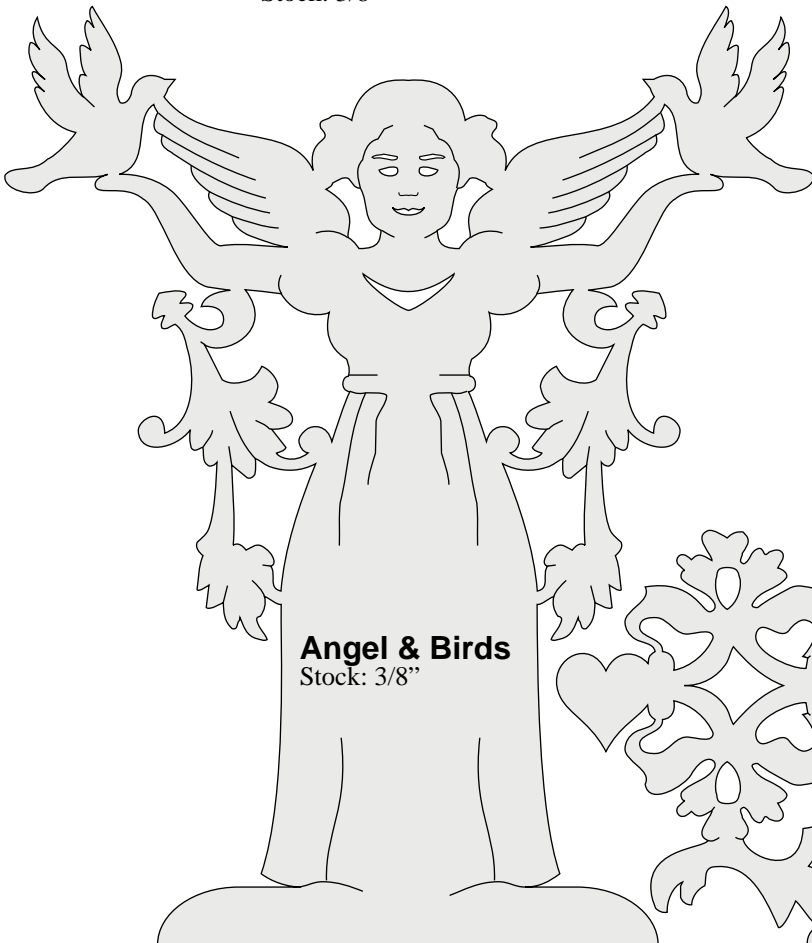

Angel & Birds
Stock: 3/8"



Victorian Heart
Stock: 3/8"

Project #35-58



Gal
Stock: 3/8"

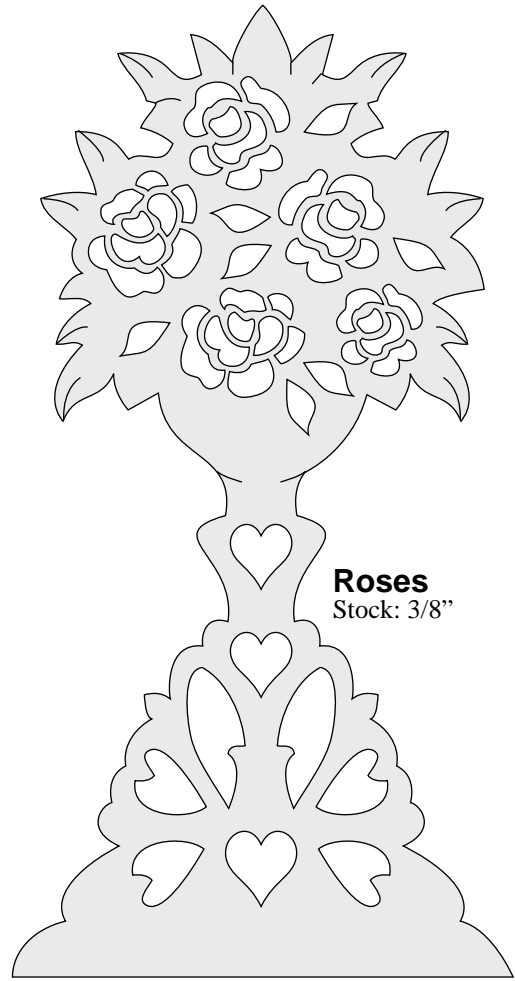

Roses
Stock: 3/8"

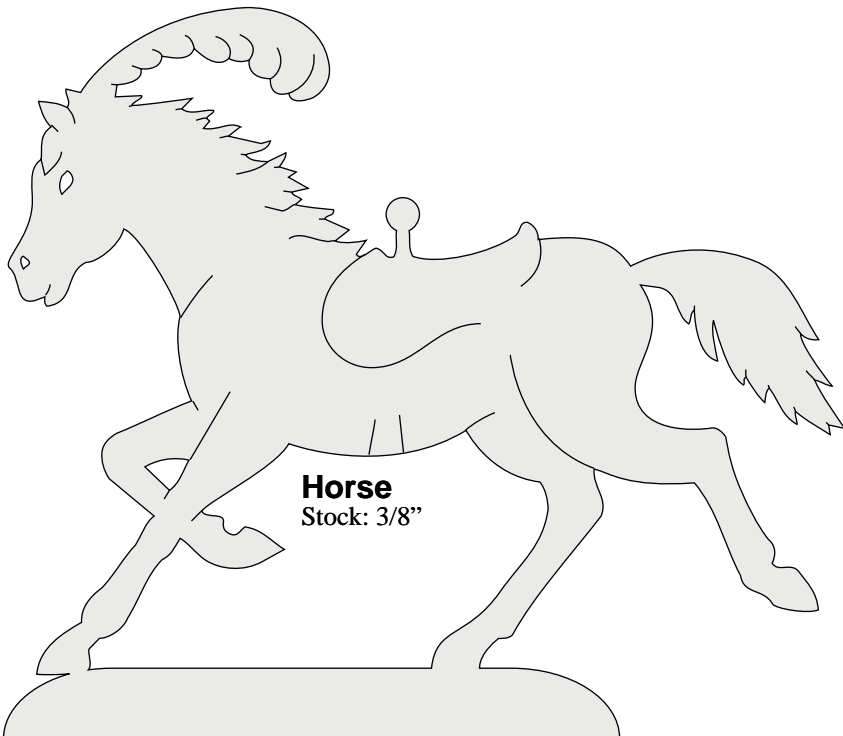

Horse
Stock: 3/8"

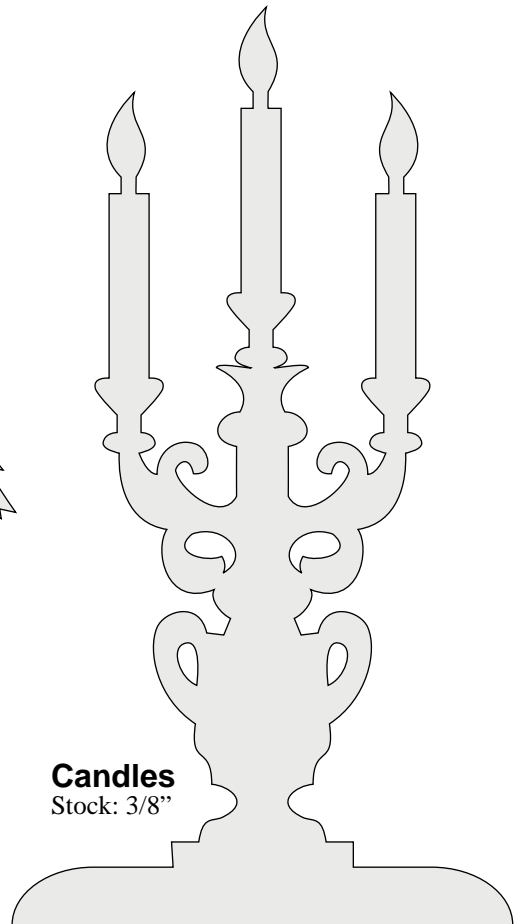

Candles
Stock: 3/8"

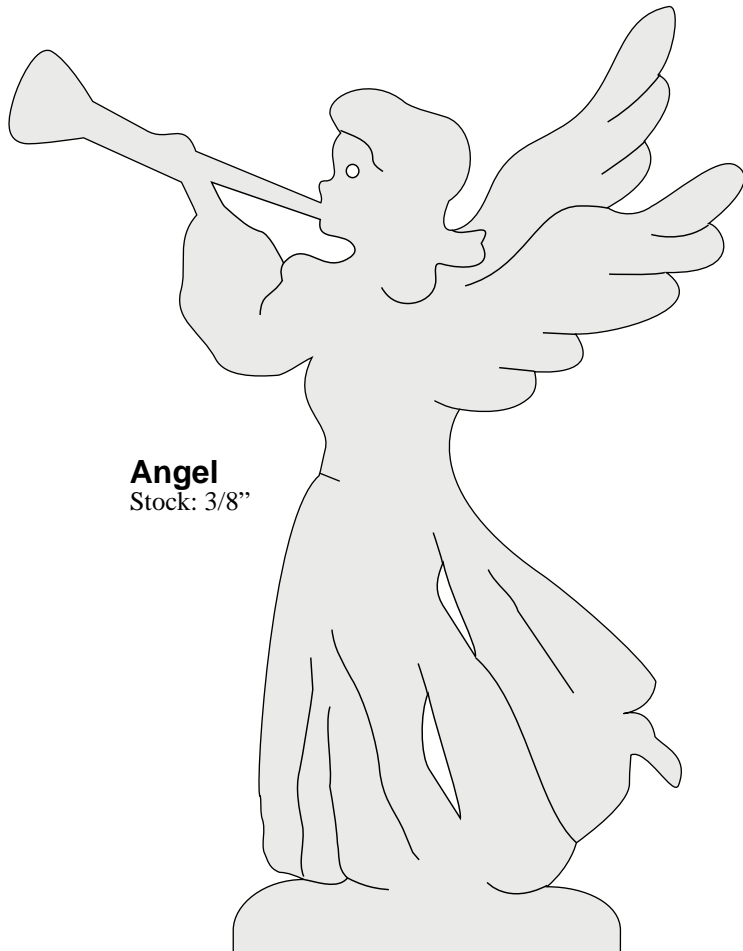

Angel
Stock: 3/8"

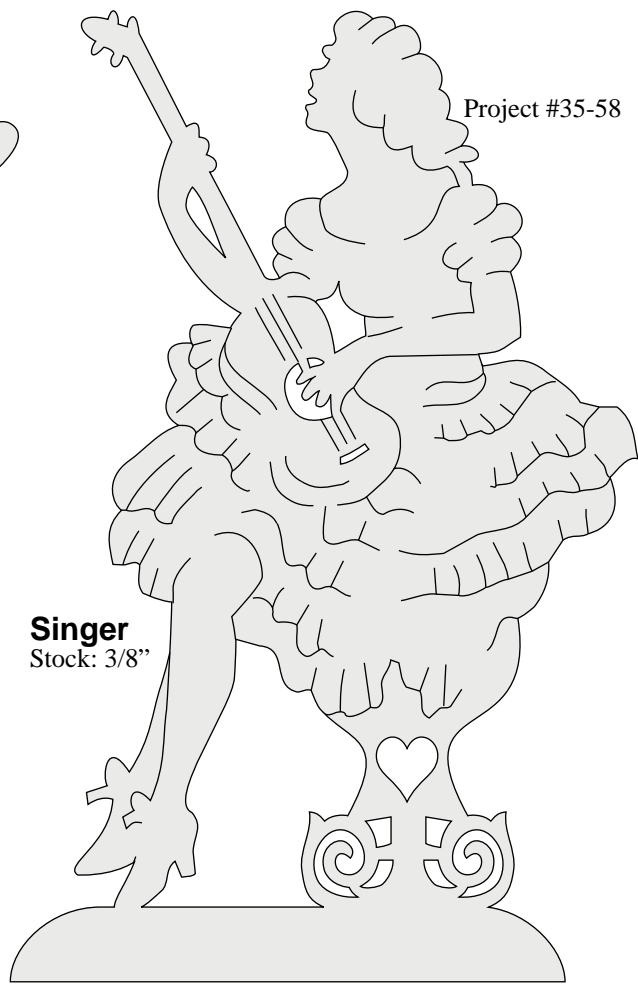

Singer
Stock: 3/8"



Flowers
Stock: 3/8"

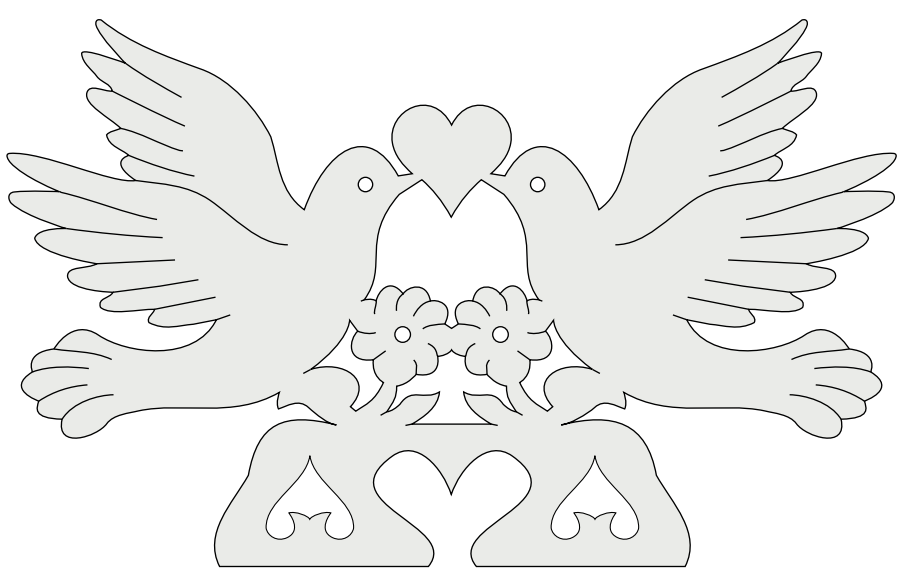

Love Birds
Stock: 3/8"

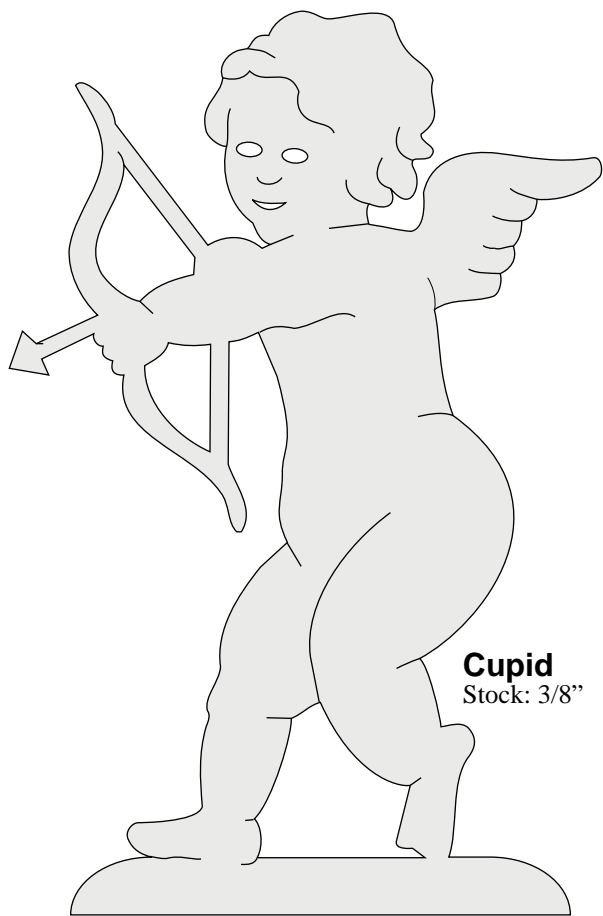

Cupid
Stock: 3/8"

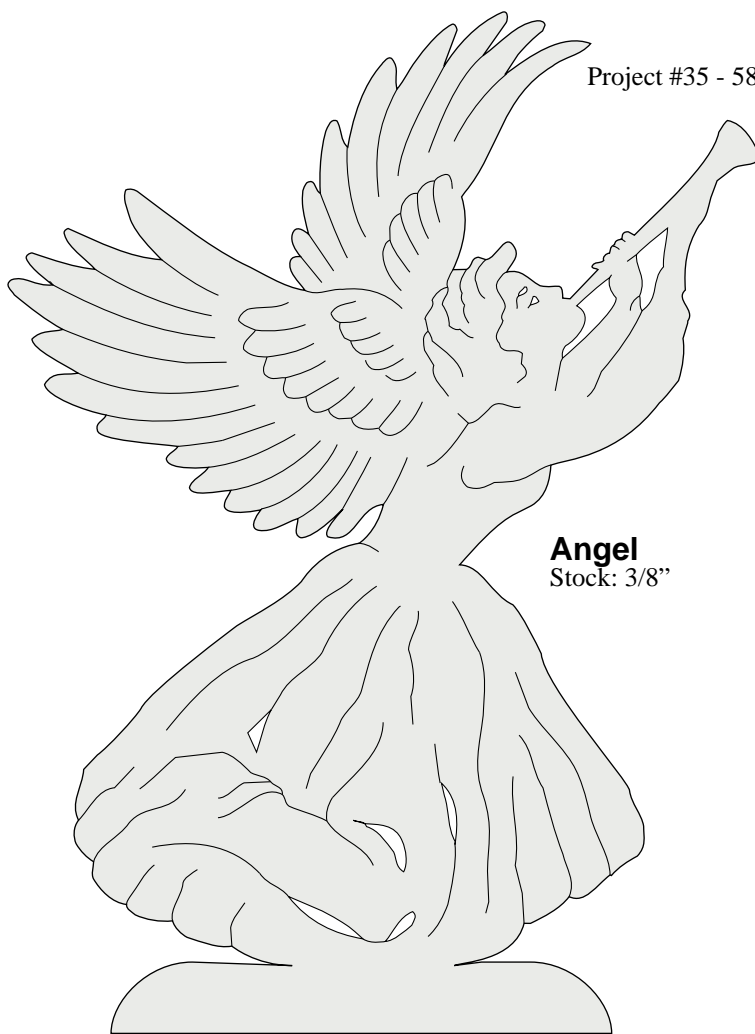

Angel
Stock: 3/8"

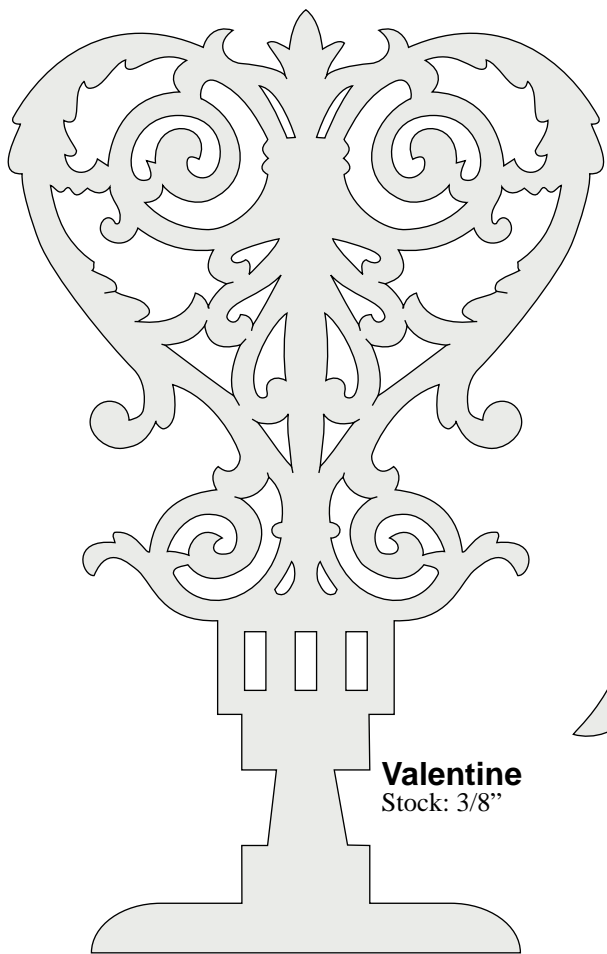

Valentine
Stock: 3/8"

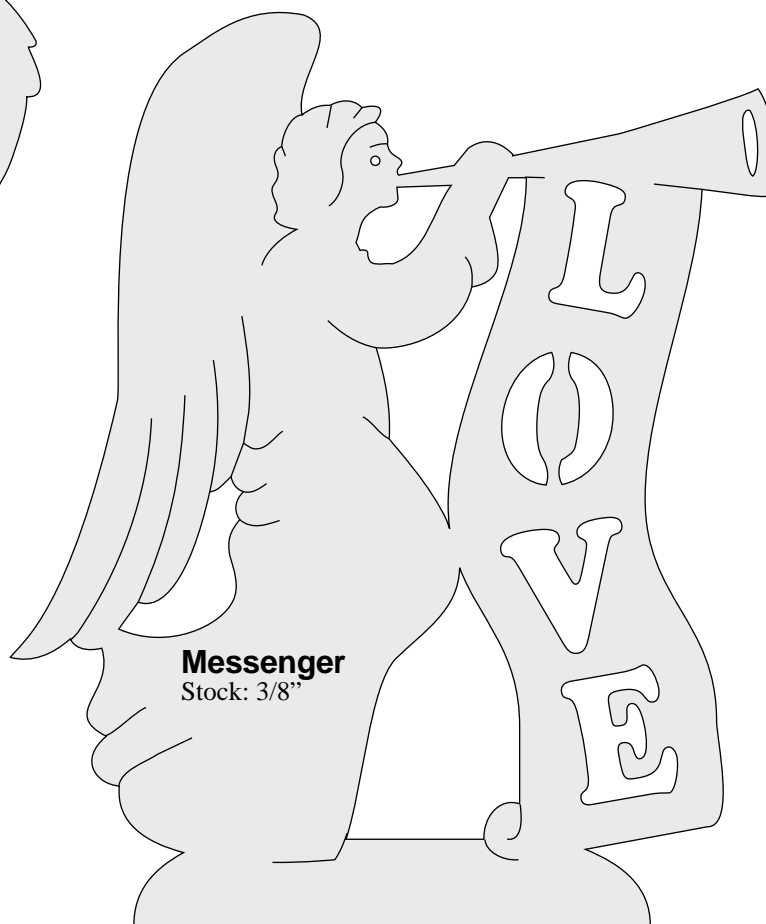

Messenger
Stock: 3/8"

Project #35-58

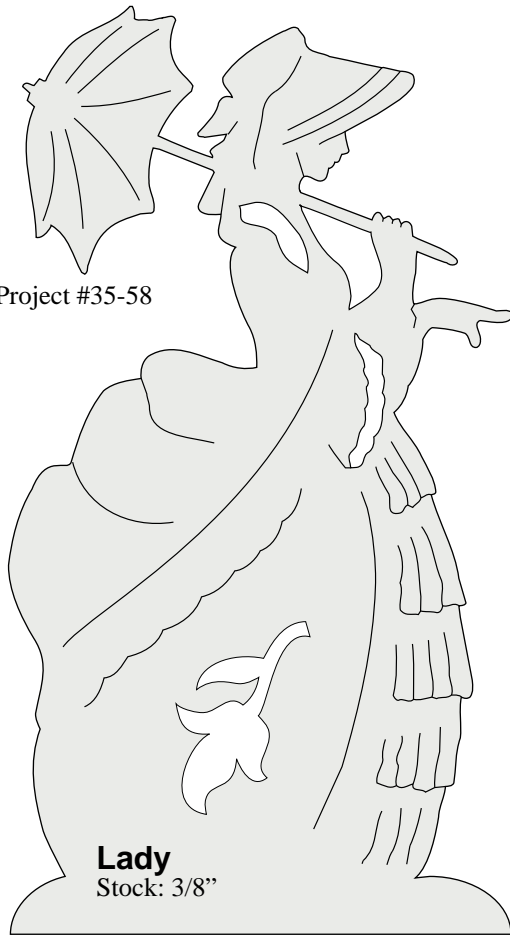

Lady
Stock: 3/8"



Gentleman
Stock: 3/8"

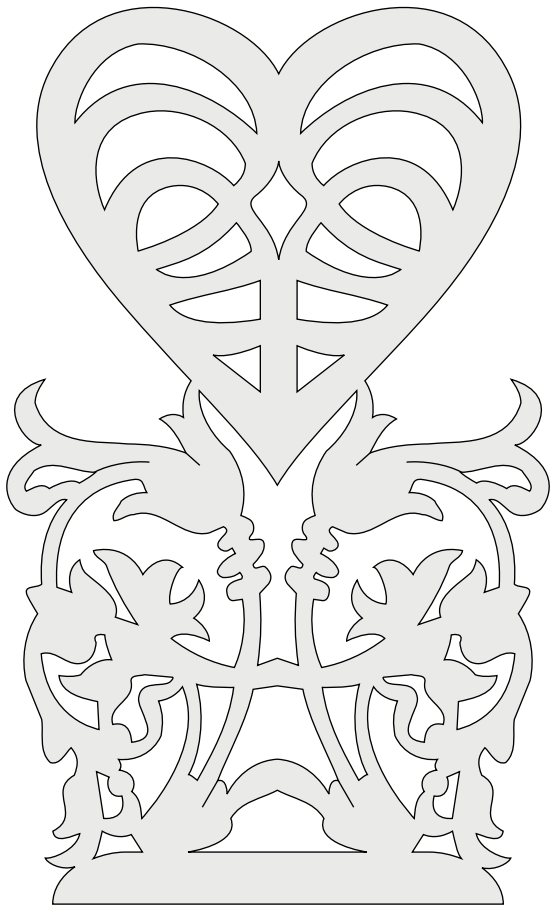

Flowerly Heart
Stock: 3/8"



Sweet Couple
Stock: 3/8"