

Folk Toys

Patterns & Projects for the Scroll Saw



Ken Folk

Folk Toys

.....
Patterns & Projects for the Scroll Saw
.....

Ken Folk

STACKPOLE
BOOKS

Copyright © 1998 by Stackpole Books

Published by
STACKPOLE BOOKS
5067 Ritter Road
Mechanicsburg, PA 17055

All rights reserved, including the right to reproduce this book or portions thereof in any form or by any means, electronic or mechanical, including photocopying, recording, or by any information storage and retrieval system, without permission in writing from the publisher. All inquiries should be addressed to Stackpole Books, 5067 Ritter Road, Mechanicsburg, Pennsylvania 17055.

The author and publisher disclaim any and all liability for the safety and design of the various items as ultimately crafted and built.

Printed in the United States of America

10 9 8 7 6 5 4 3

FIRST EDITION

Cover design by Wendy Reynolds

Cover photograph by bet Photographic Illustrations

Contents

Introduction

6

The Projects

Shorebird	8	Lady and Her Flock	42
Lumberjacks	12	Hinged Snake	46
Ladies Churning Butter	16	Flying Chicken	48
Zebra Hobbyhorse	20	Climbing Monkey	52
Horse with Moving Rider	22	Pedaling Cyclist	56
Diving Frog	26	Walking Crocodile	62
Walking Pig	30	Hand-Powered Railcar	66
Court Jester	34	Hinged Dachshund	70
Walking Rabbit	36	Beetle	72
Hinged Crocodile	40		

Sources of Supply

77

Metric Conversions

78

Introduction

One surefire way to put smiles on children's faces is to give them amusing toys with moving parts. Early American toymakers realized this and went to great lengths to provide plenty of eye-catching antics with animation.

Early toys were crude and scarce because the colonists' lives consisted of long hours of labor with little time or money for amusement for themselves or their children. The Industrial Revolution, however, brought increased prosperity and leisure time to Americans, and toymaking developed. By the second half of the nineteenth century, hinges, cranks, and mechanical devices became common features on wooden folk toys. Soon, ingenious toy manufacturers built on these ideas as well as on techniques for clockworks passed down from their European fathers, and a multimillion-dollar industry was at hand.

The world has changed since that time. Plastic and video dominate the market. But these clever toys still offer timeless appeal for home craftsmen and their children. This book offers a collection of patterns for animated classics that were popular during the late-nineteenth and early-twentieth centuries as well as

some of my own designs. You'll find a woman with a moving staff herding a flock of waddling geese, birds with nodding heads and flapping wings, animals that scuttle across the floor, and a beetle with feelers that swing from side to side. The toys are operated with pull cords, cranks, hard motions, or simple gravity.

PLANNING THE PROJECT

All of the projects in this book contain full-size patterns. My favorite method for transferring the shape of each part onto the wood is to use cardboard patterns that can be moved around for best position and then traced. Start by photocopying the patterns from the book. Then glue the copies onto a thin sheet (about $\frac{1}{8}$ -inch thick) of poster board. It can be easily cut with scissors, but it's stiff enough to trace. I buy the 22-by-38-inch size for less than \$1 at arts-and-crafts or stationary stores.

If you are a novice scroll sawer and need more information on techniques, consult John Nelson's *Patterns and Projects for the Scroll Saw*, published by Stackpole Books.

MATERIALS

Most of the toys in this book require about one square foot of wood, so cost is not a significant part of the project. Pick a wood that is strong, resists splintering, and finishes well. Hard maple has these qualities in addition to a very tight grain, which makes it easy to get a glass-smooth finish with paint or varnish. You'll find that cutting and sanding hard maple is slow going, but the improved appearance and life of the toy make it worth the extra effort.

ASSEMBLY AND FINISHING

Before assembly, make sure that the parts have been smoothly sanded and that all corners and edges have been rounded to at least a 1/32-inch radius to prevent splintering. Then temporarily assemble the toy without glue to make sure that there is a loose fit between the moving parts. When you're satisfied with the fit, disassemble the toy and apply the finish to each part except for glued surfaces, pivot joints, and wheel axles.

There are many alternatives for finishing your toys, but whatever you choose, it must be nontoxic. For

painted surfaces, I prefer an oil-base primer and topcoat for durability and a sprayed-on lacquer finish for the clear parts.

The last step is to apply the facial, body, and ornamental details. There are two ways to do this type of decorating: hand painting and sign film. For hand painting, make a full-size photocopy of the decoration, transfer it onto the project with carbon paper, and then paint in the details. The sign film technique is an excellent alternative for those who don't want to attempt hand painting. Sign film is made in dozens of colors and is sold by the foot at art supply stores. The film is about as thick as a human hair, so that when applied it's difficult to tell the difference from paint. To begin, transfer the decoration on to the sign film using a photocopy and carbon paper. Cut out the detail with a scissors or craft knife. Peel off the paper backing and apply it to the project. If it doesn't look right, remove it and try again.

To ensure that the toy runs smoothly, rub some candle wax on the wearing surfaces of the axles, pivots, and rubbing parts for lubrication. To finish, assemble the toy with a quality yellow glue or epoxy.

SHOREBIRD

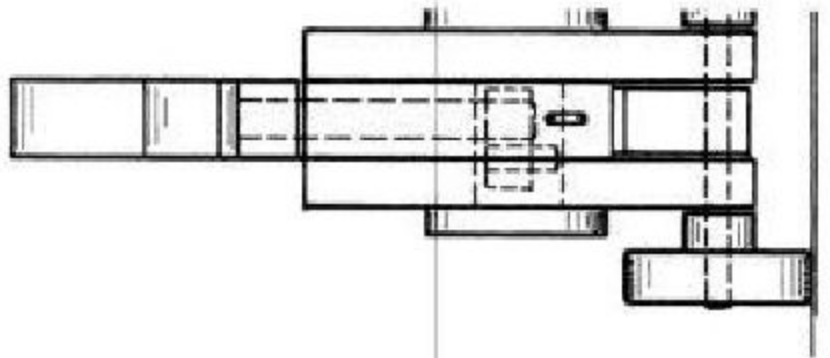
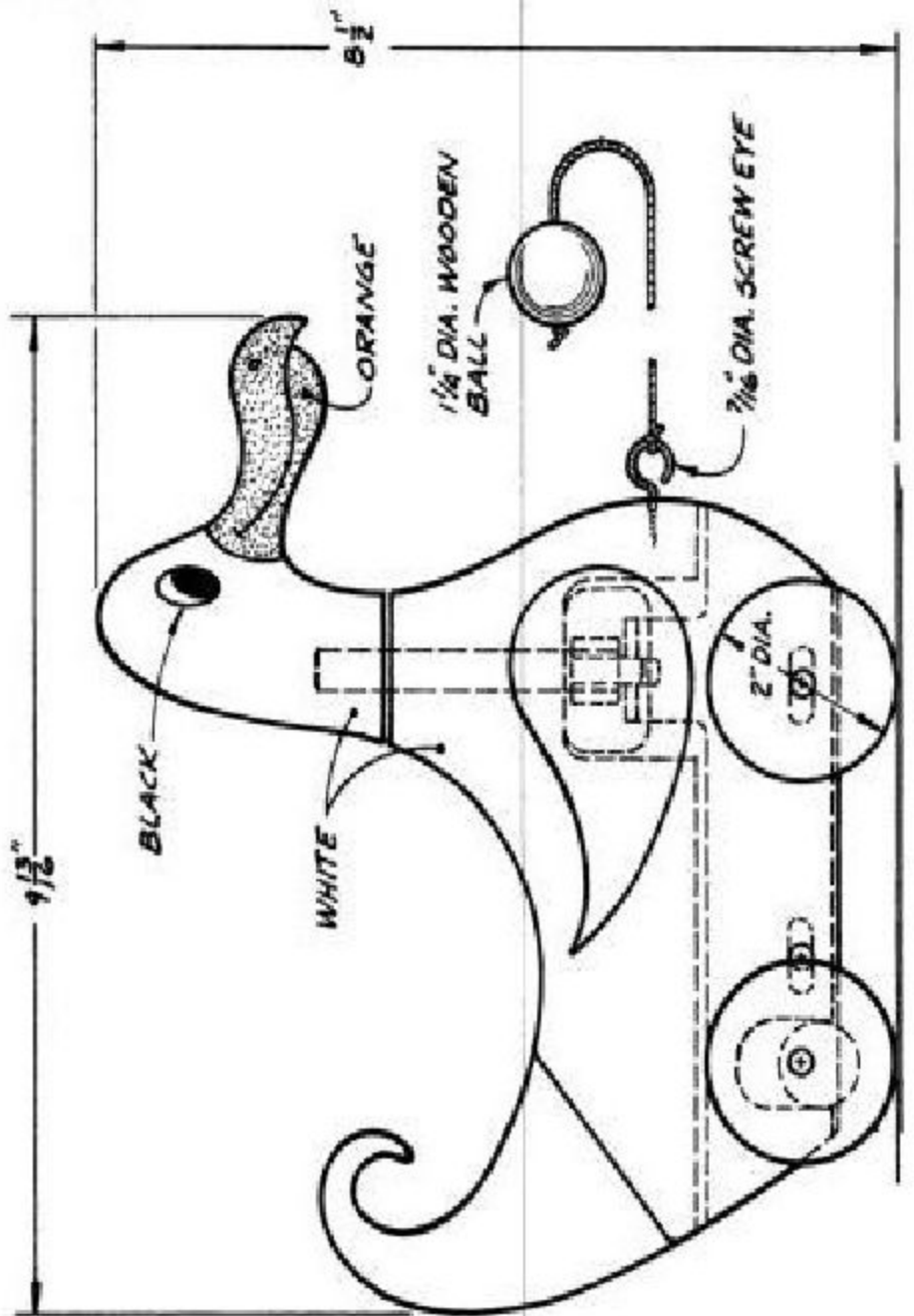
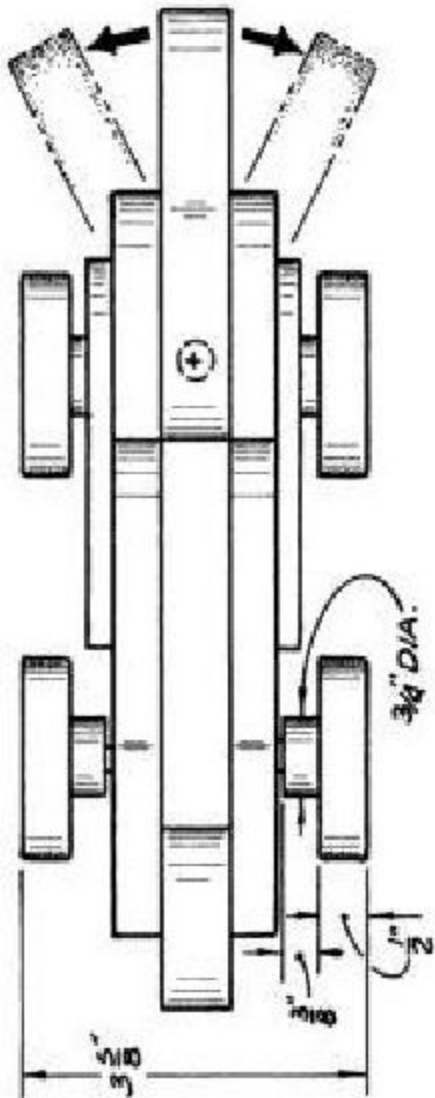

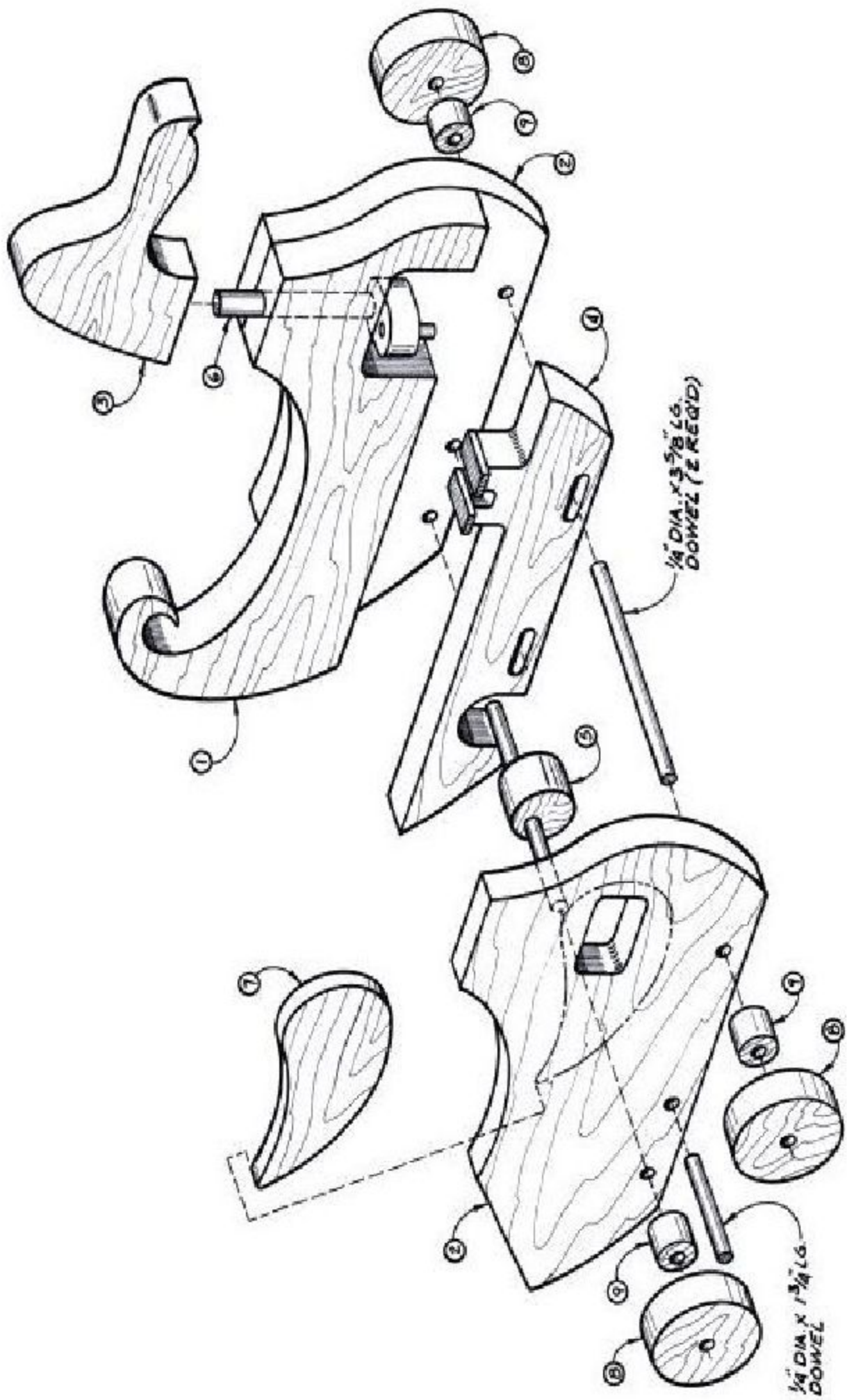

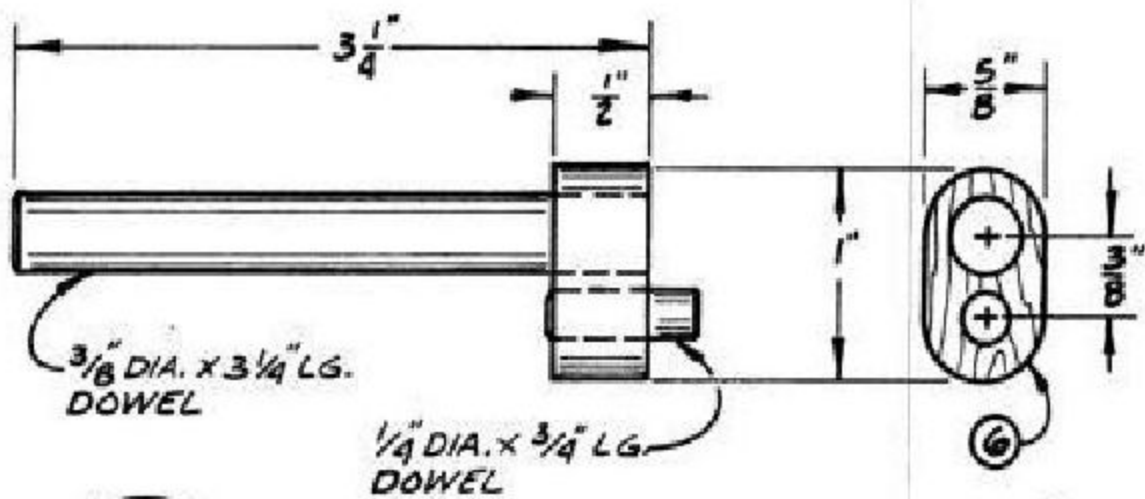

HEAD PIVOT & CRANK

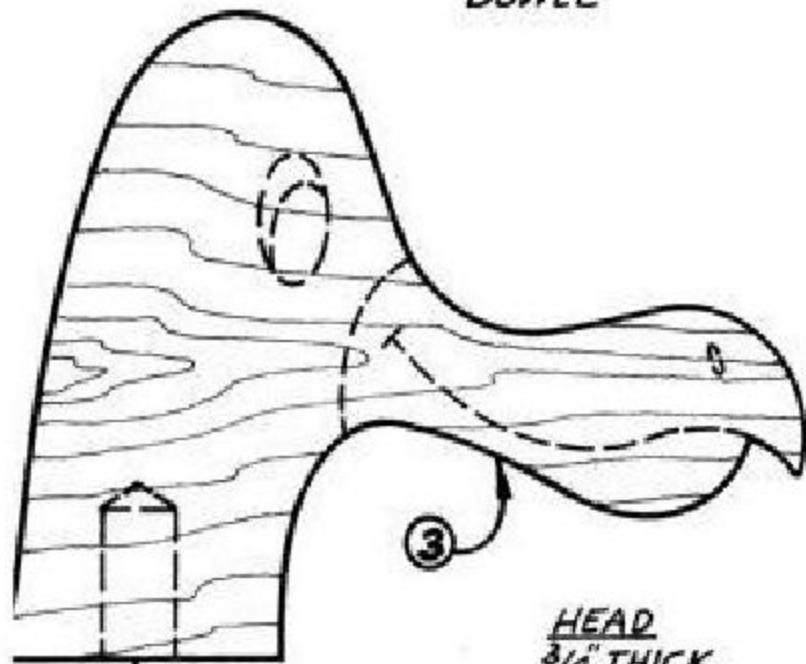

HEAD
3/4" THICK

3/8" DIA. X 1 1/16" DP.

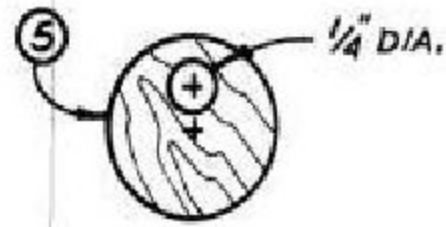

DRIVE DISK
23/32" THICK

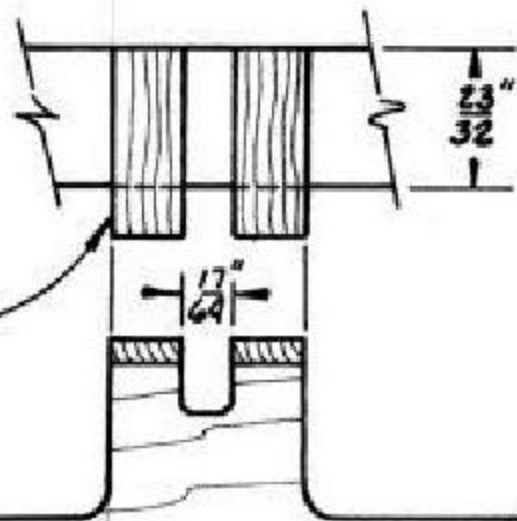

1/8" x 3/8" x 15/16",
GLUE IN PLACE



SHOREBIRD
FULL-SIZE PATTERNS

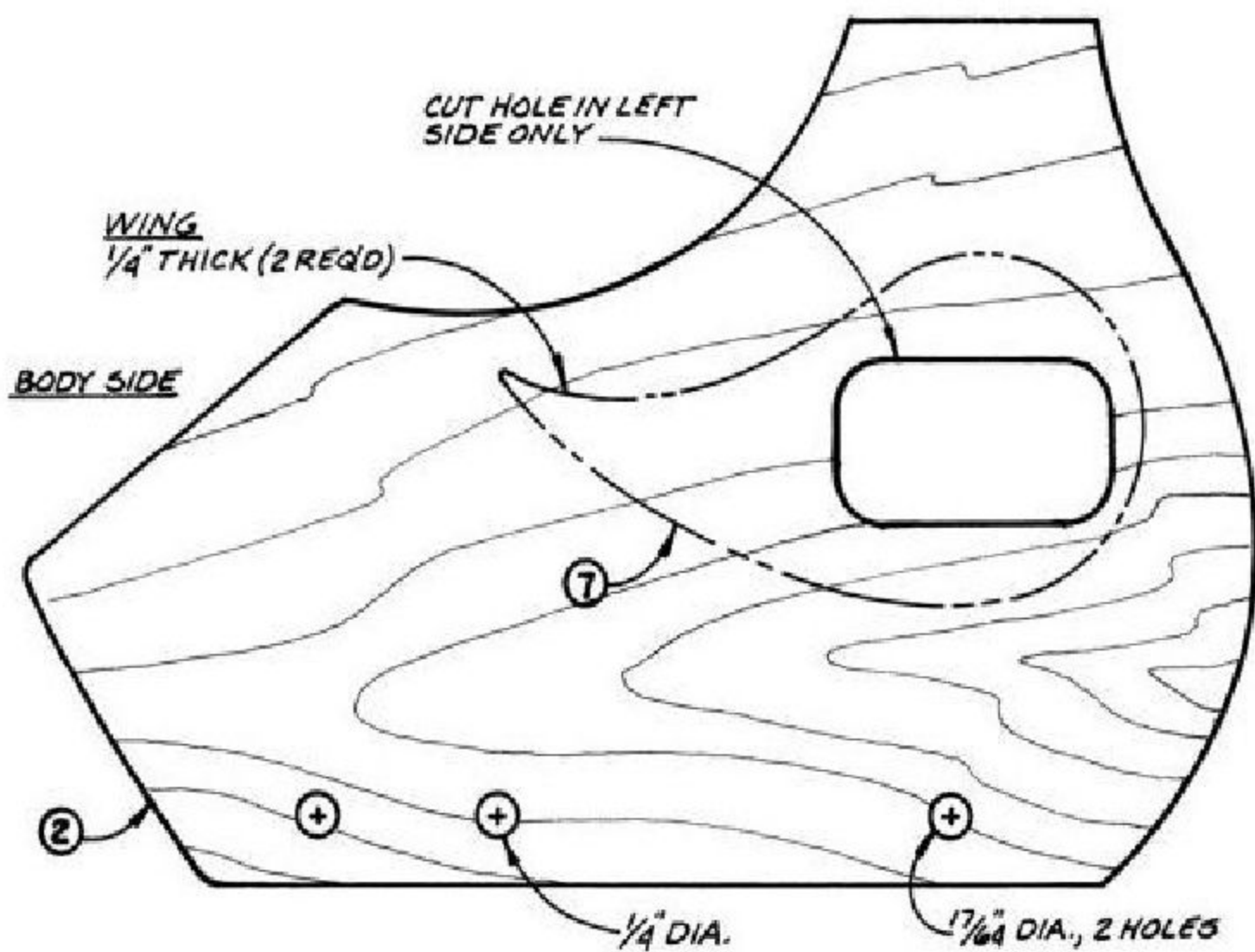
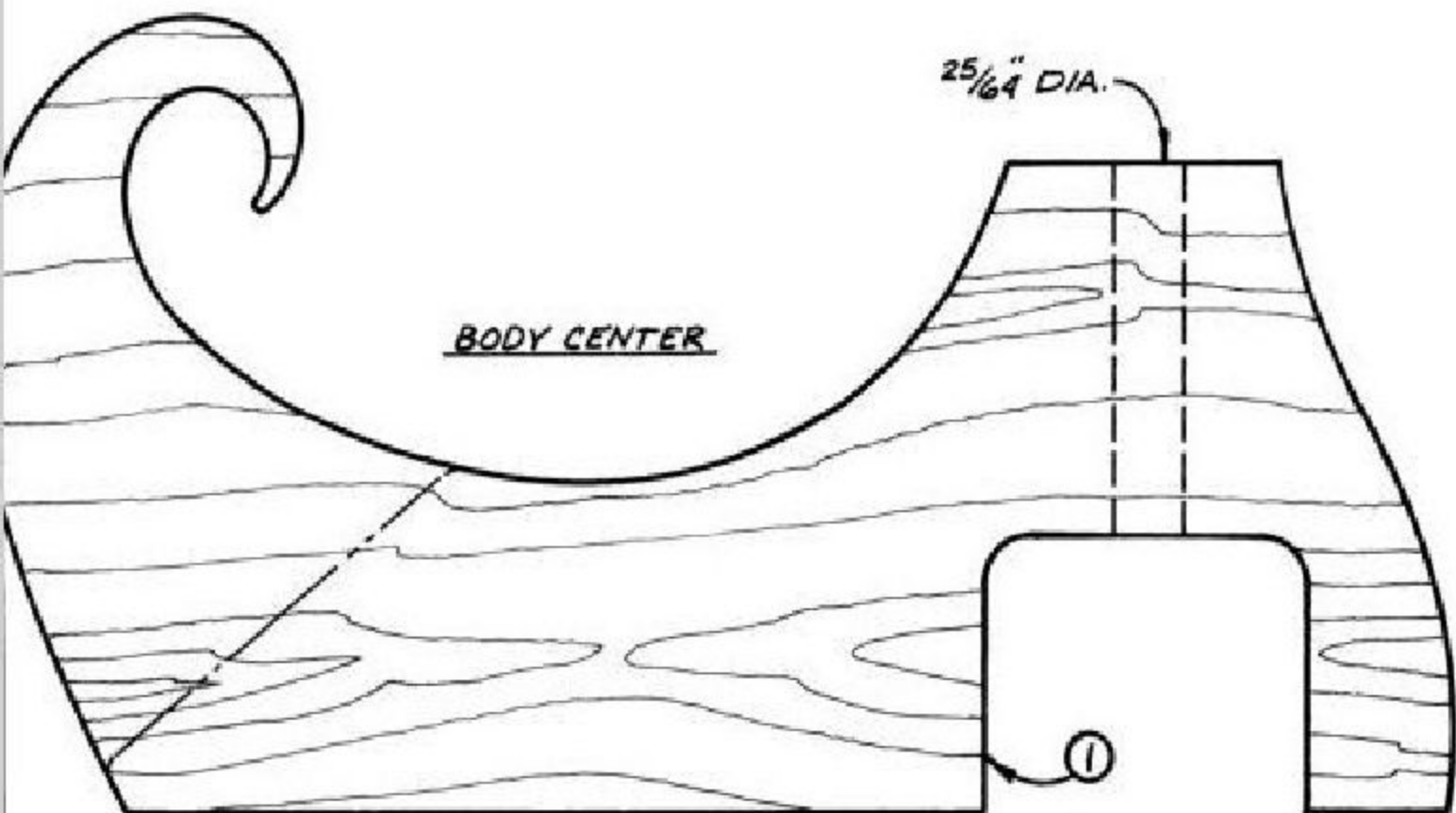

LUMBERJACKS

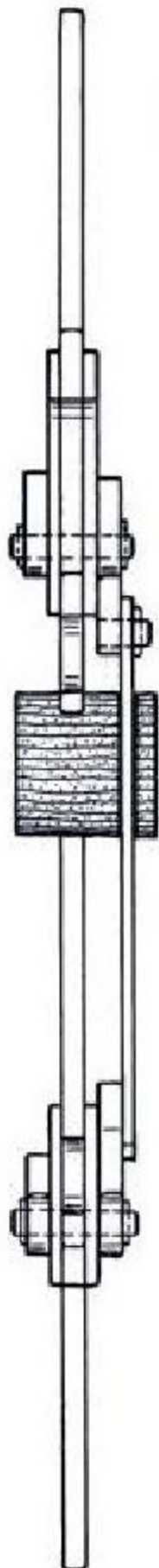

TOP VIEW

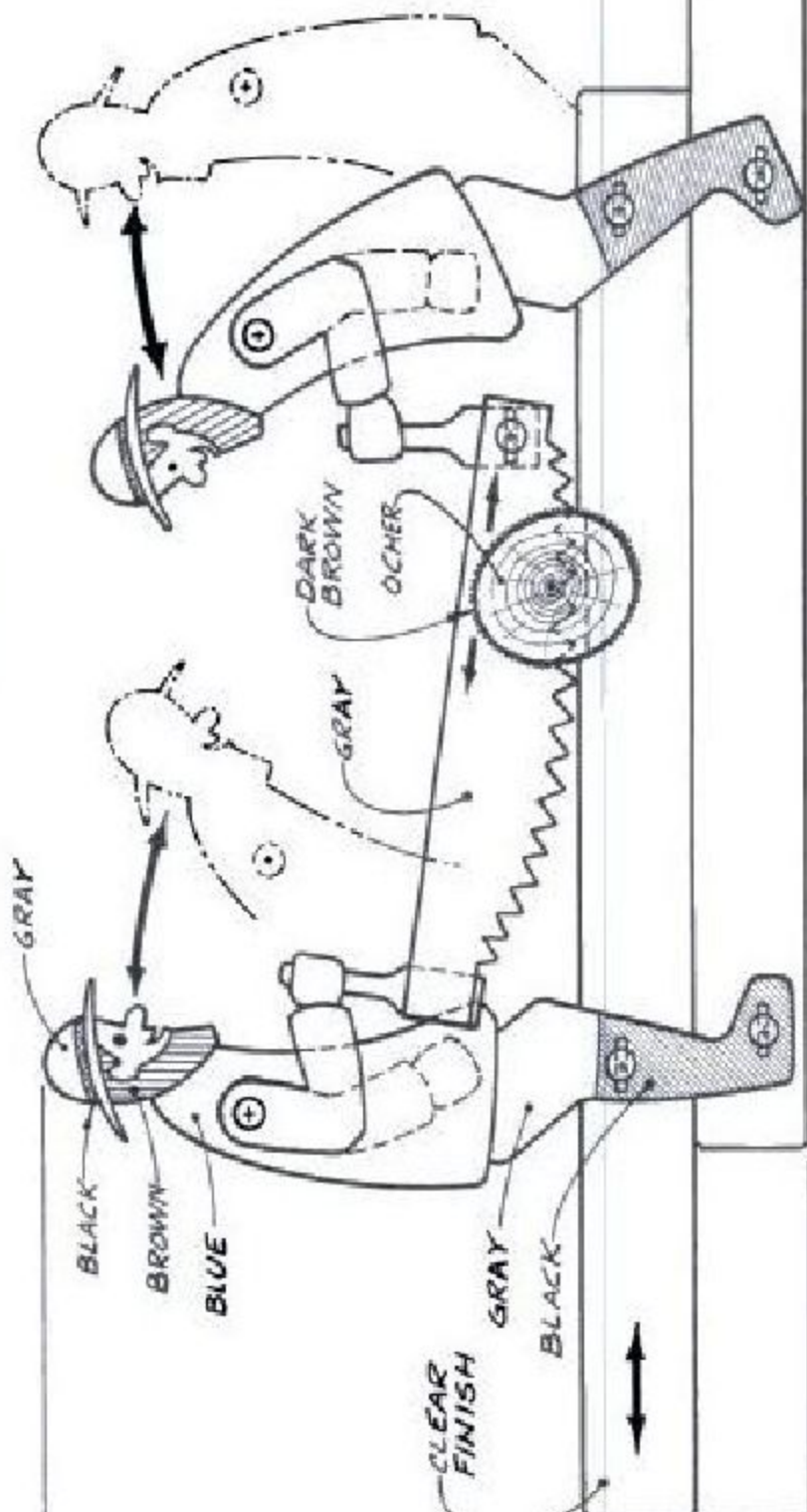

FRONT VIEW

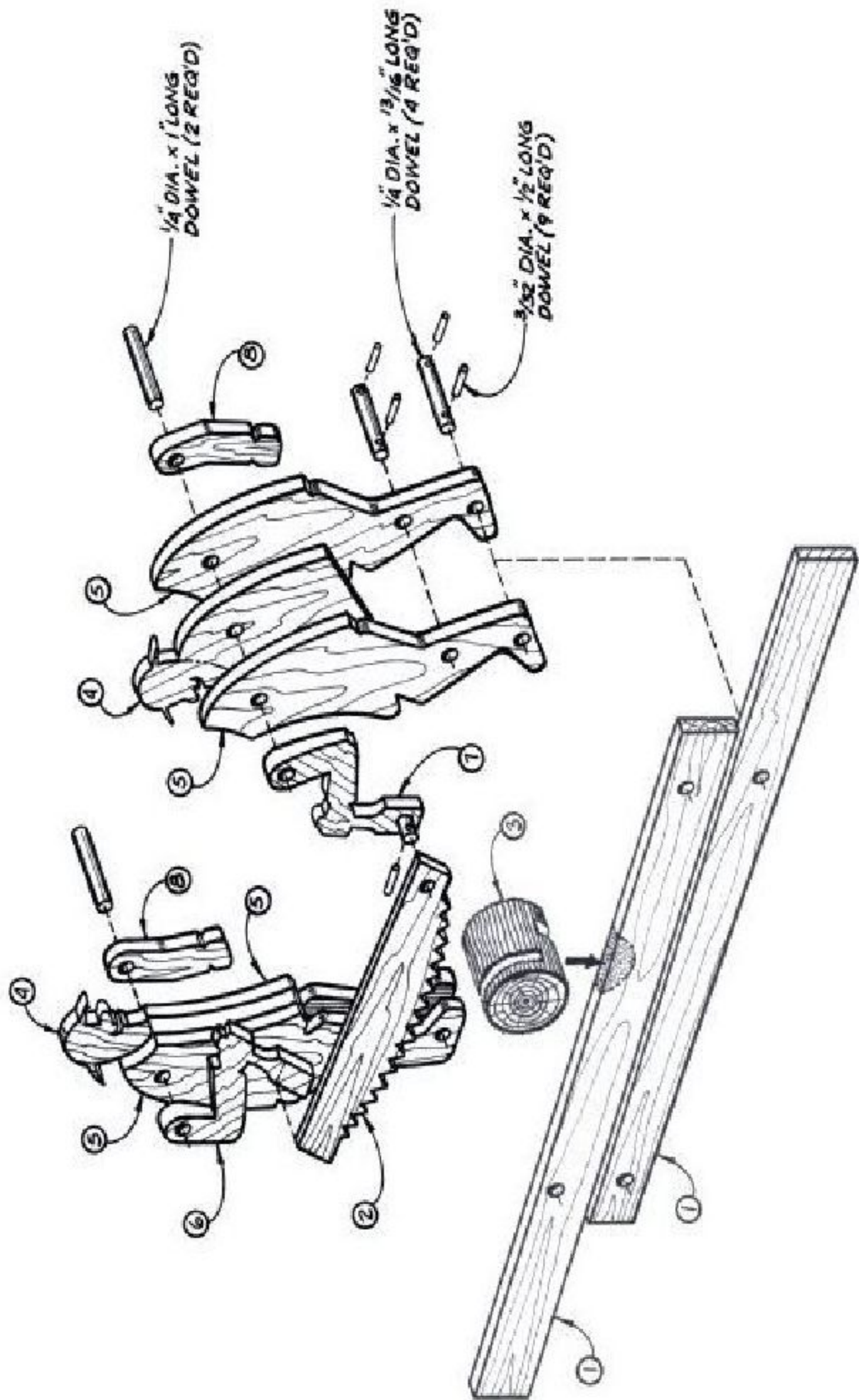

LUMBERJACKS

FULL-SIZE PATTERNS

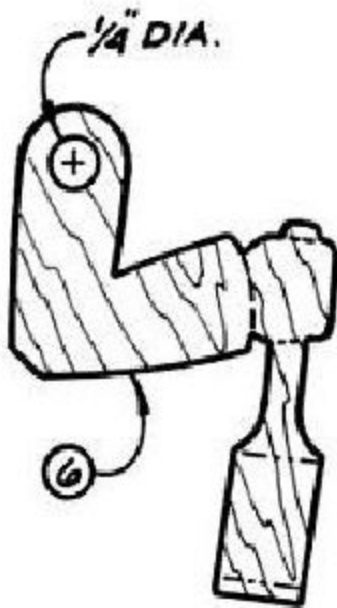

ARM
1/4" THICK (2 REQ'D)

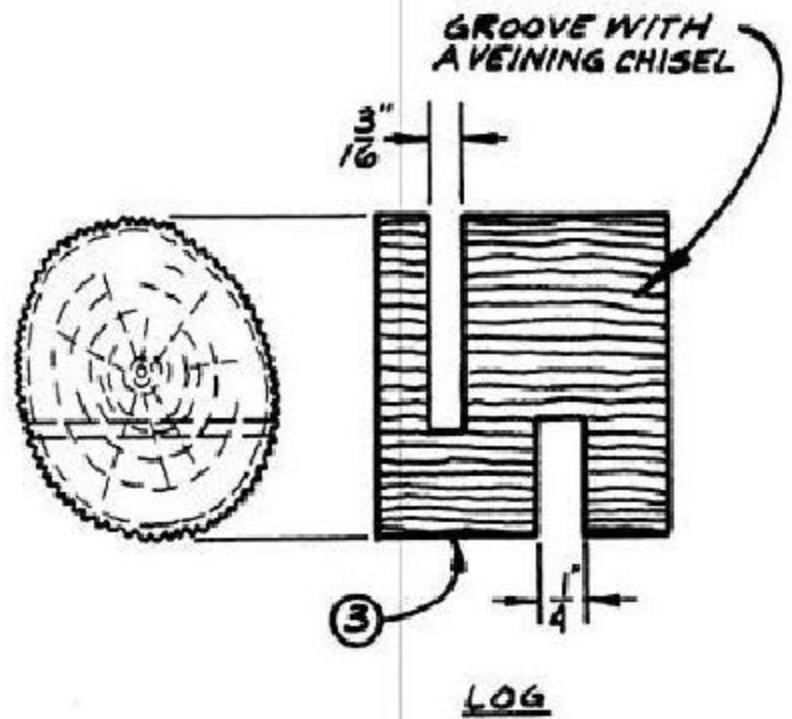

BODY CENTER
1/4" THICK (2 REQ'D)



ARM
1/4" THICK (2 REQ'D)

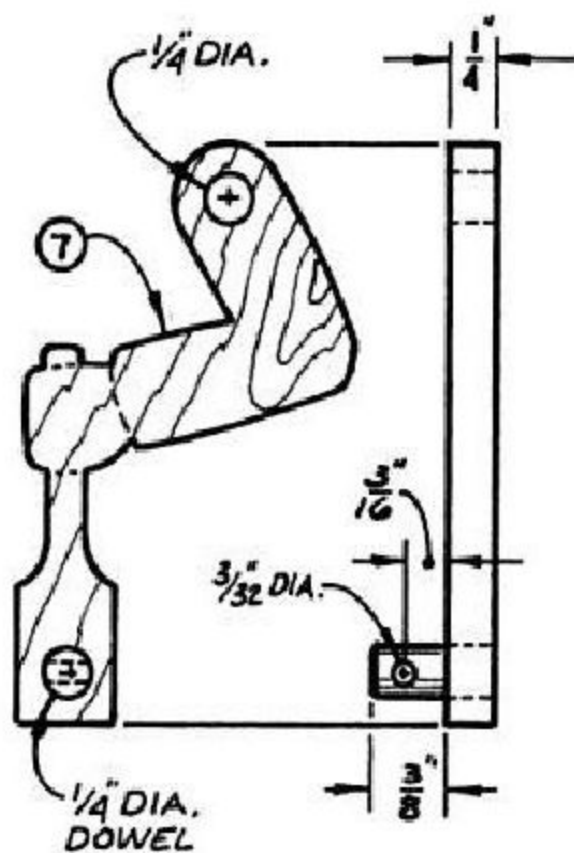
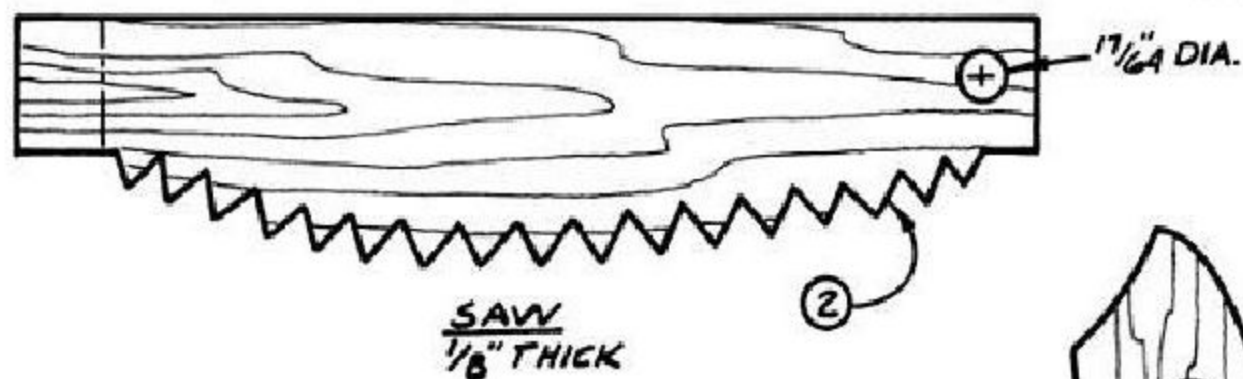
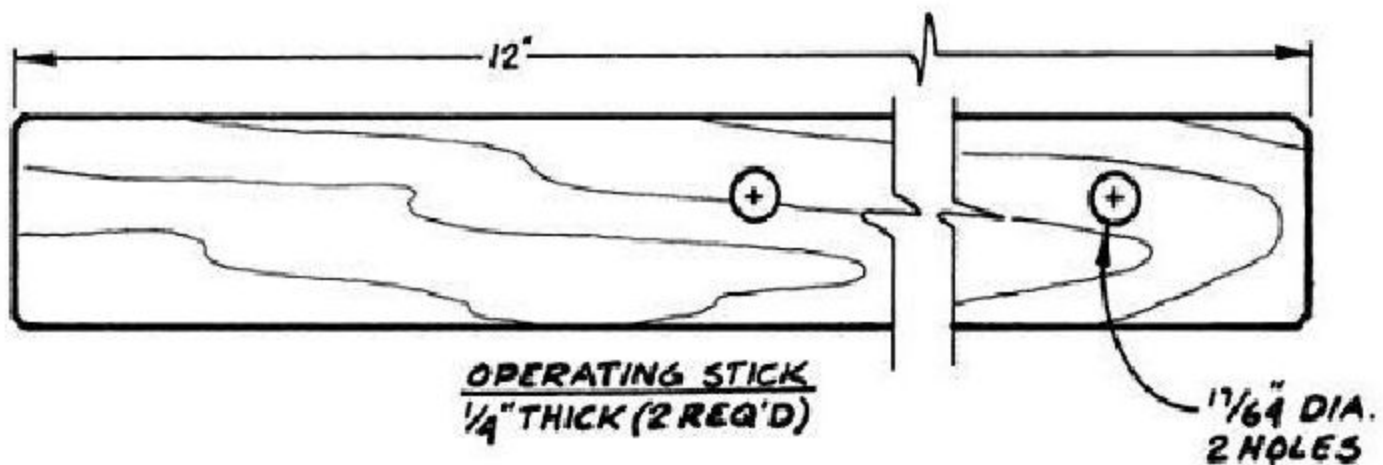

PIVOTING ARM
(2 REQ'D)

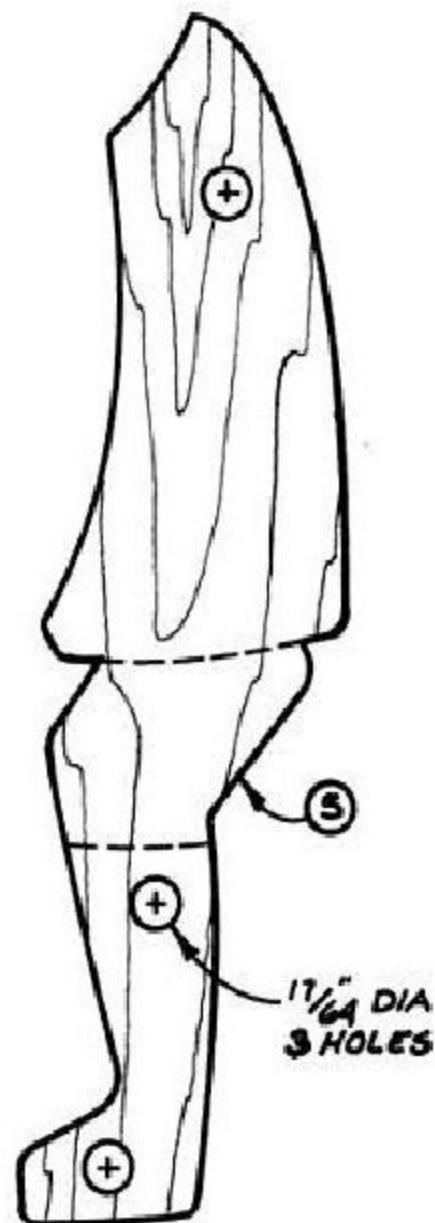

BODY SIDE
1/8" THICK (4 REQ'D)

LADIES CHURNING BUTTER

TOY'S ACTION

HAND CRANK ROTATION CAUSES THE CHURN HANDLE TO STROKE UP AND DOWN AND THE LADIES TO MOVE FROM SIDE TO SIDE

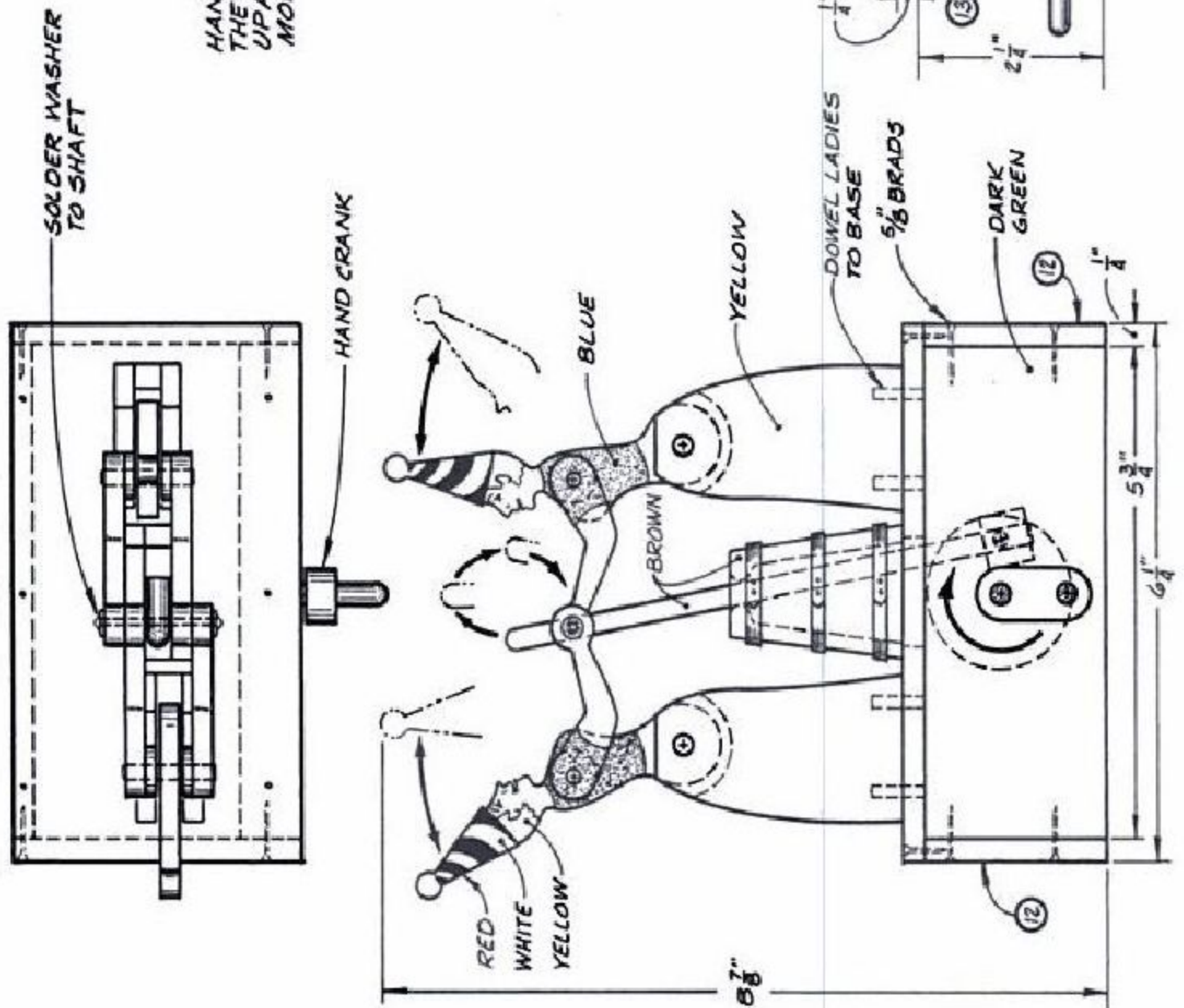

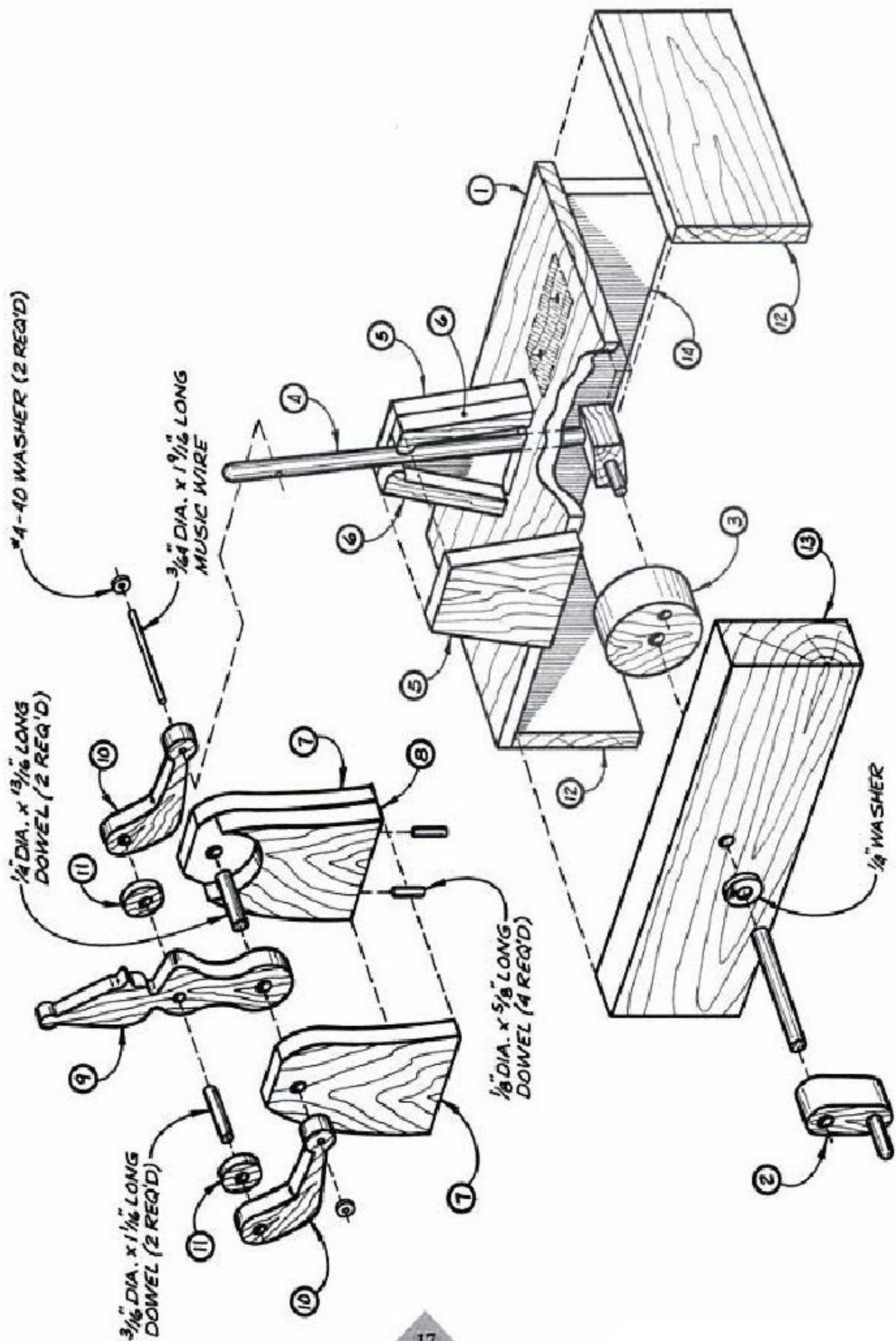

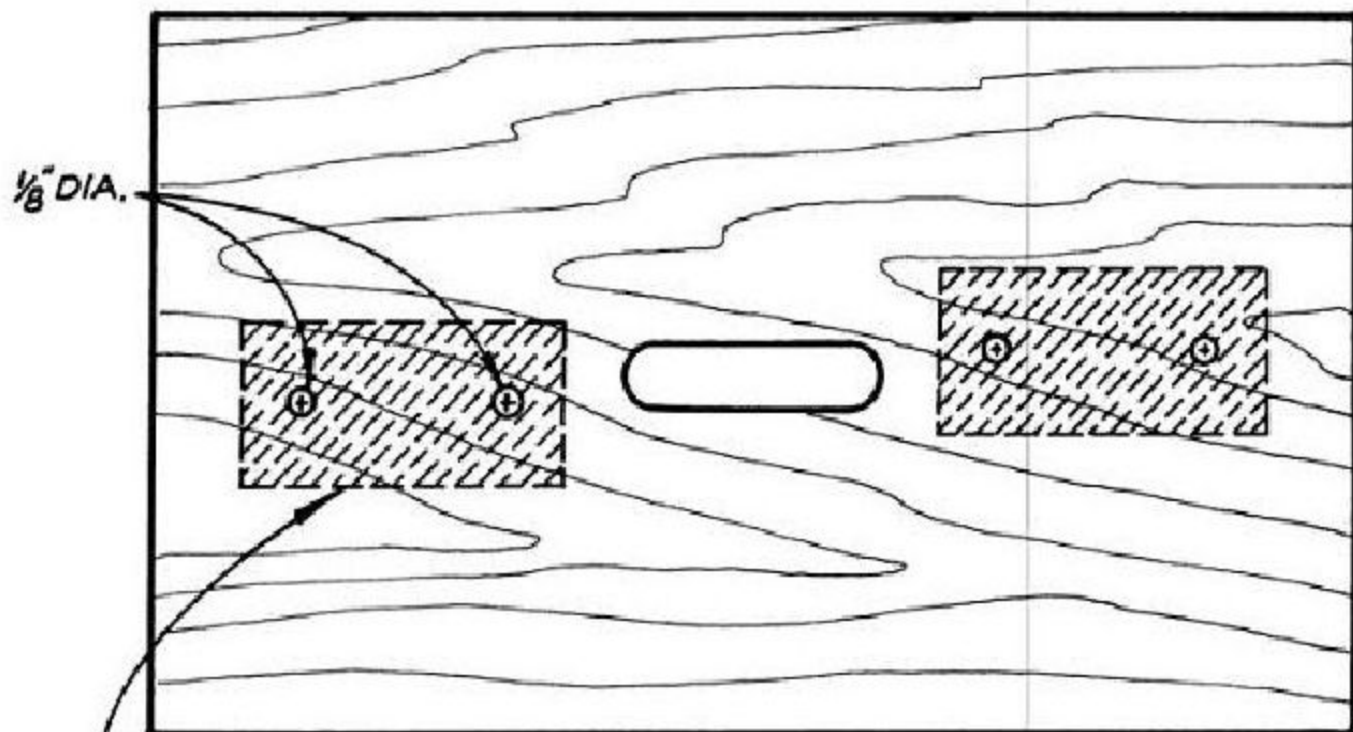

BASE
1/4" THICK

POSITION OF
LADY



ARM SPACER
1/8" THICK (4 REQ'D)

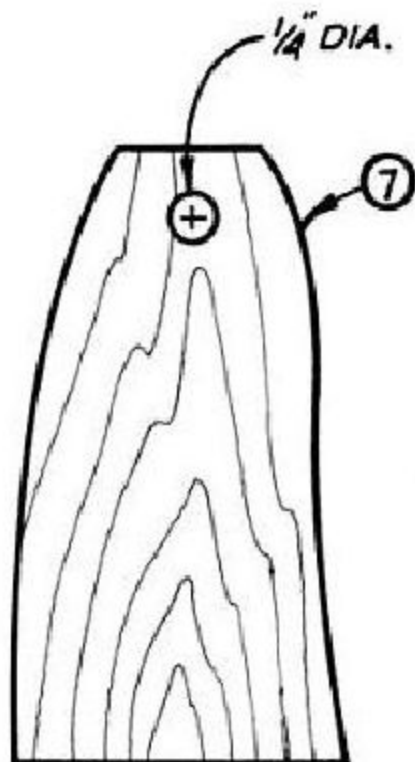

SKIRT
1/4" THICK (4 REQ'D)

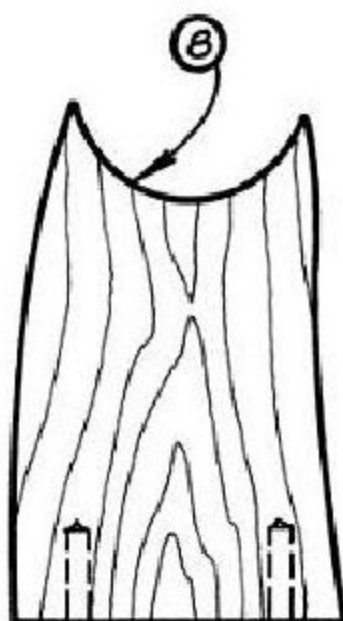

SKIRT CENTER
3/16" THICK (2 REQ'D)

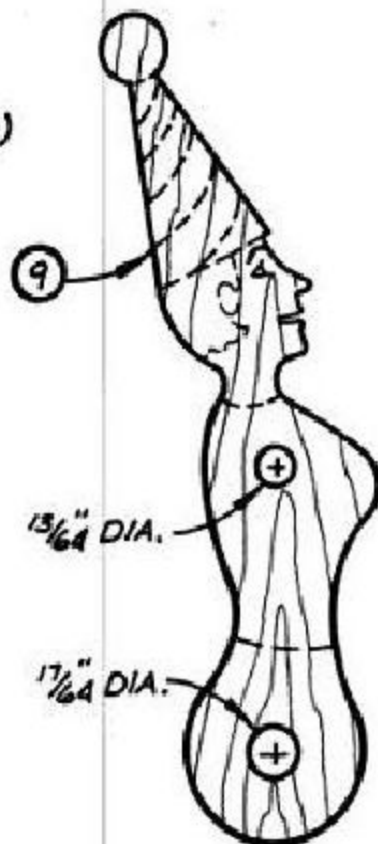

LADY
1/4" THICK (2 REQ'D)

LADIES CHURNING BUTTER FULL-SIZE PATTERNS

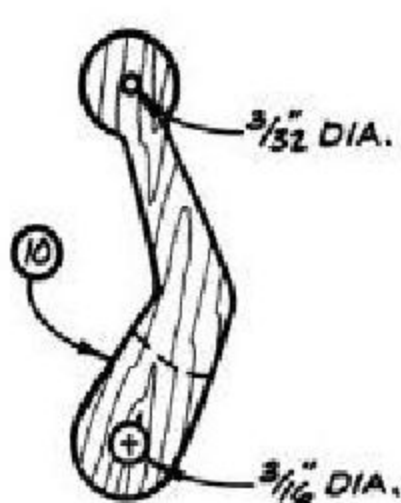
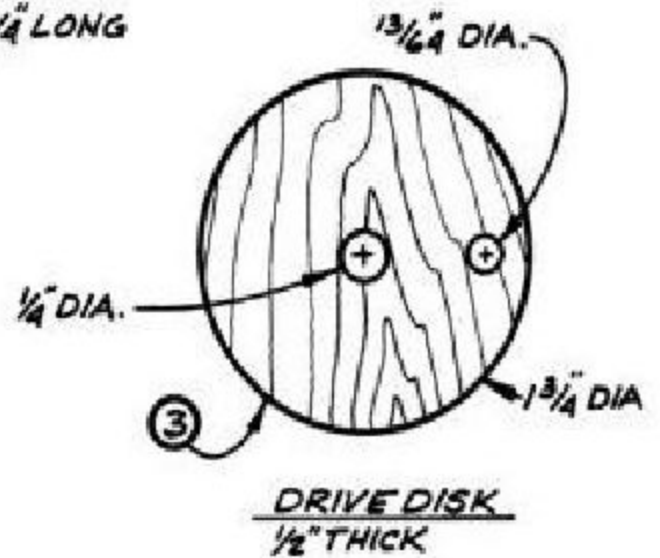
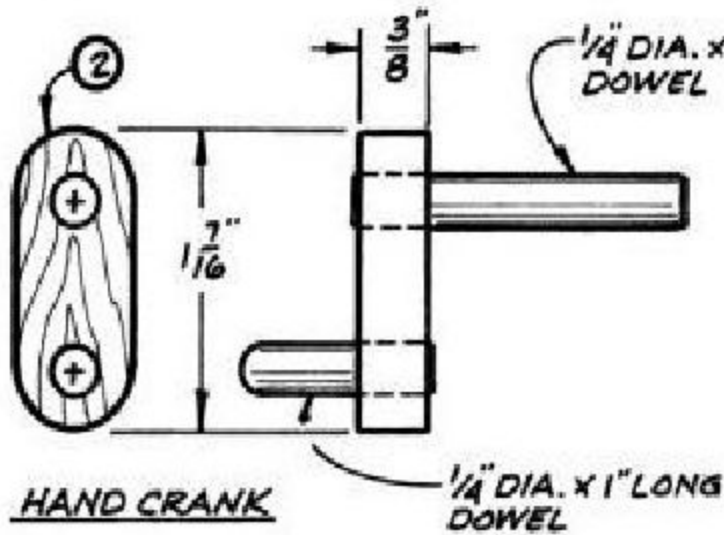
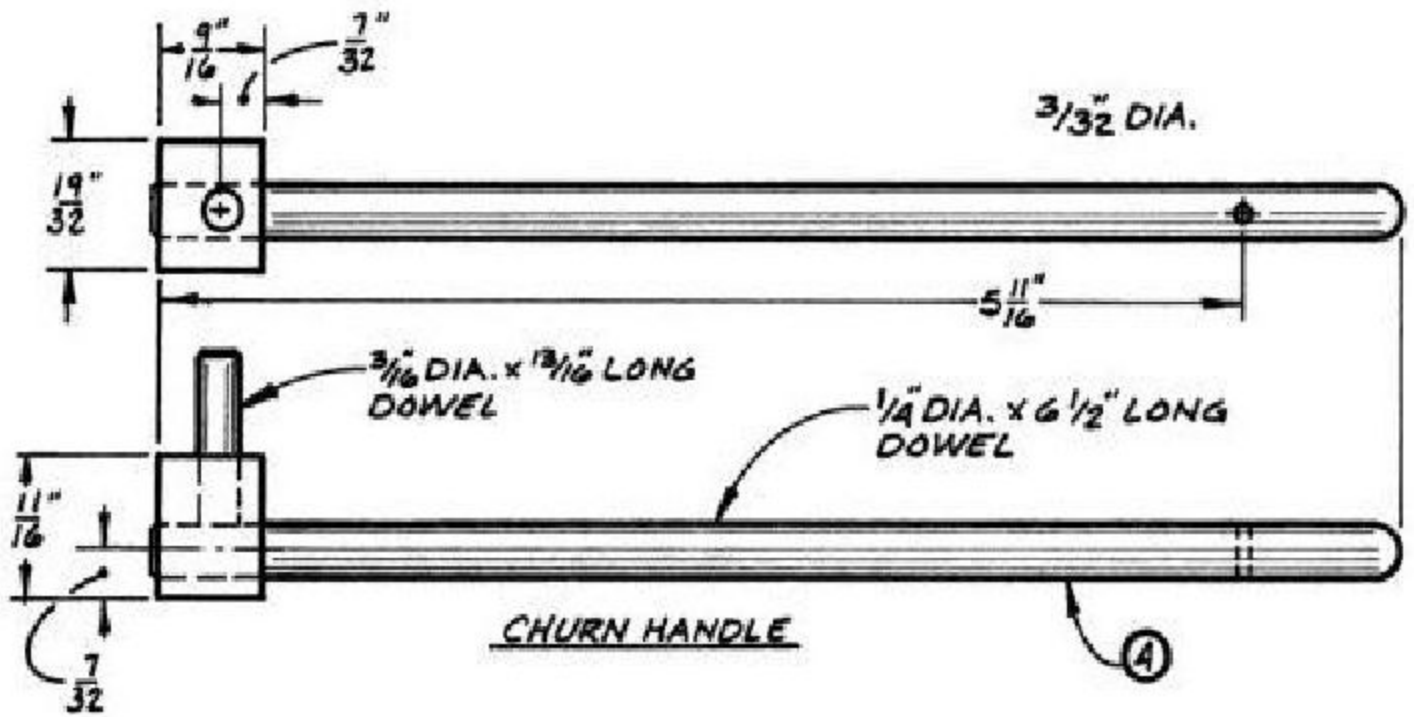

ARM
1/4" THICK (4 REQ'D)



SPACER
5/16" THICK (2 REQ'D)

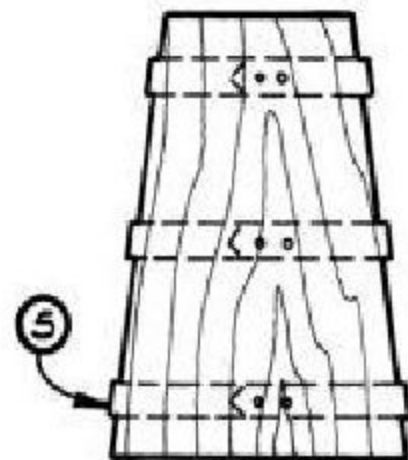

CHURN
1/4" THICK (2 REQ'D)

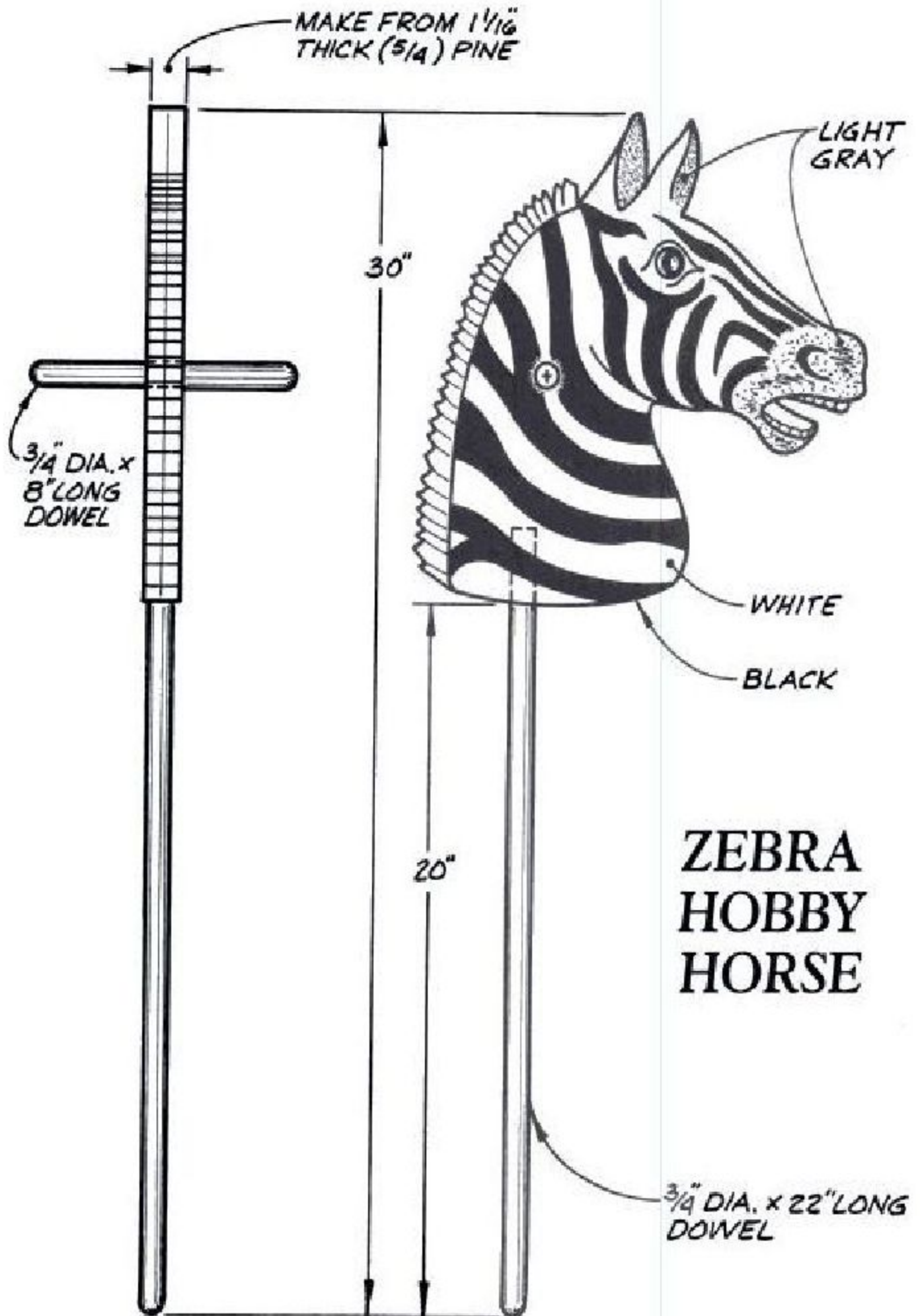

ZEBRA HOBBY HORSE

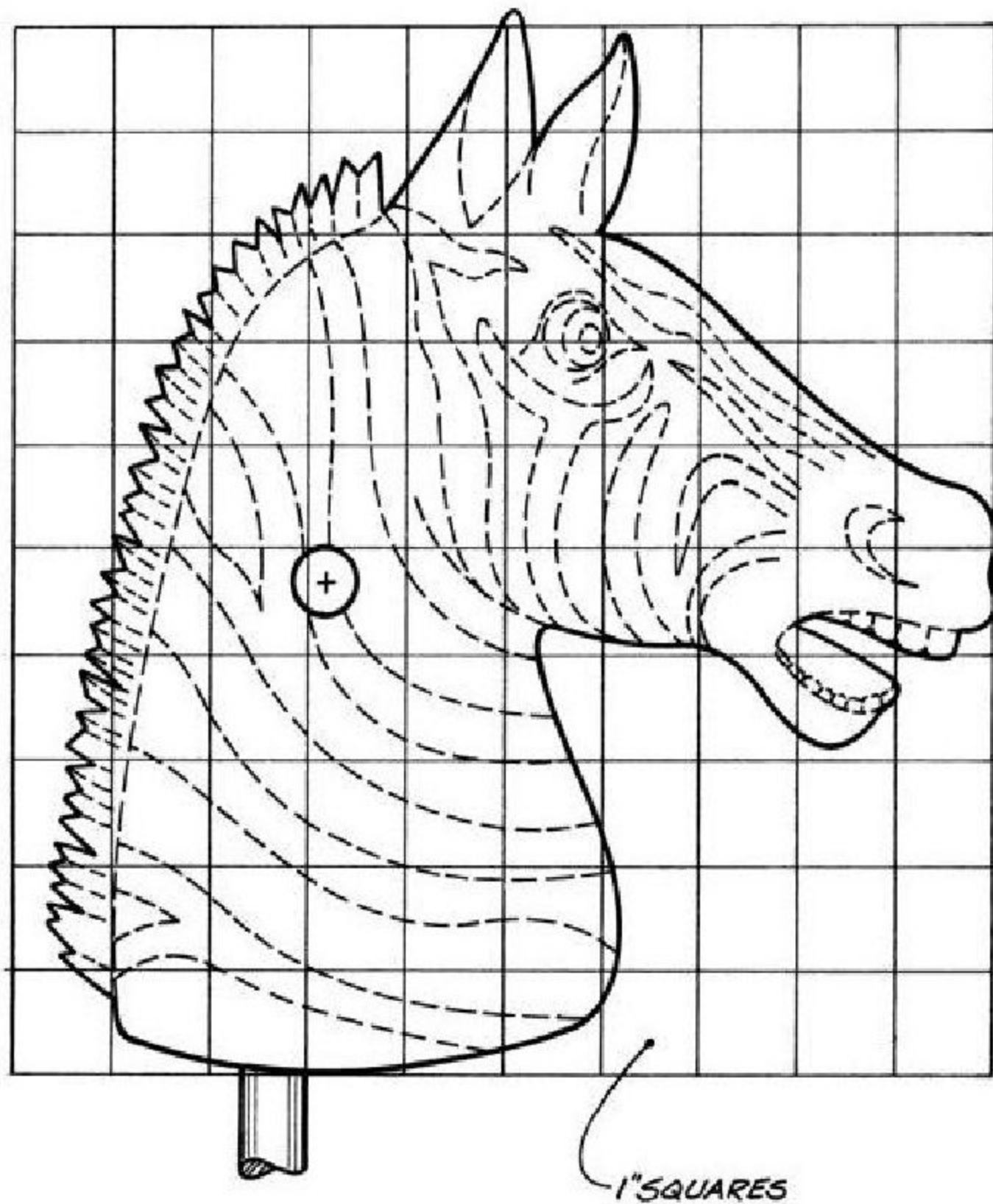

FULL-SIZE PATTERN

HORSE WITH MOVING RIDER

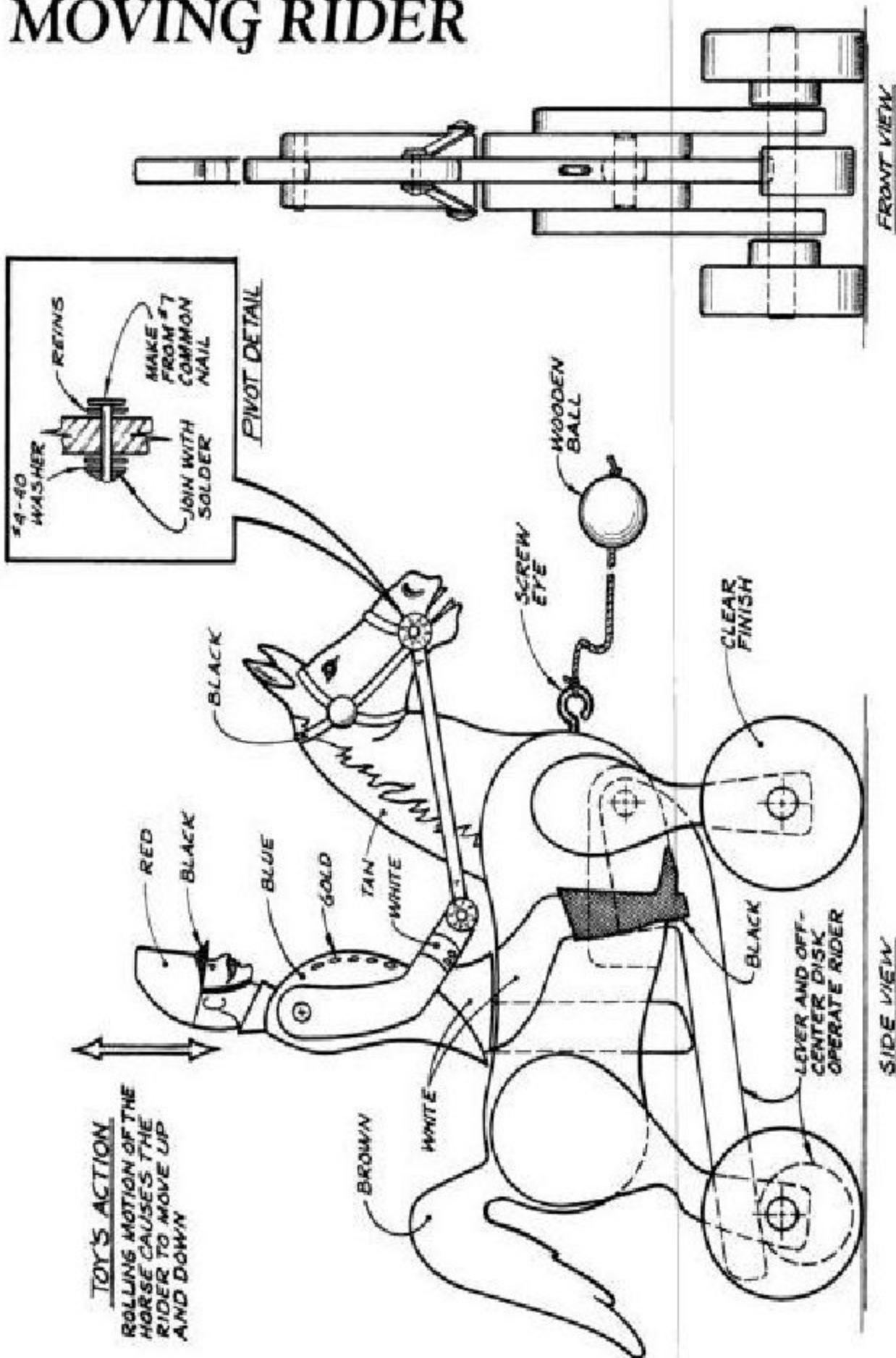

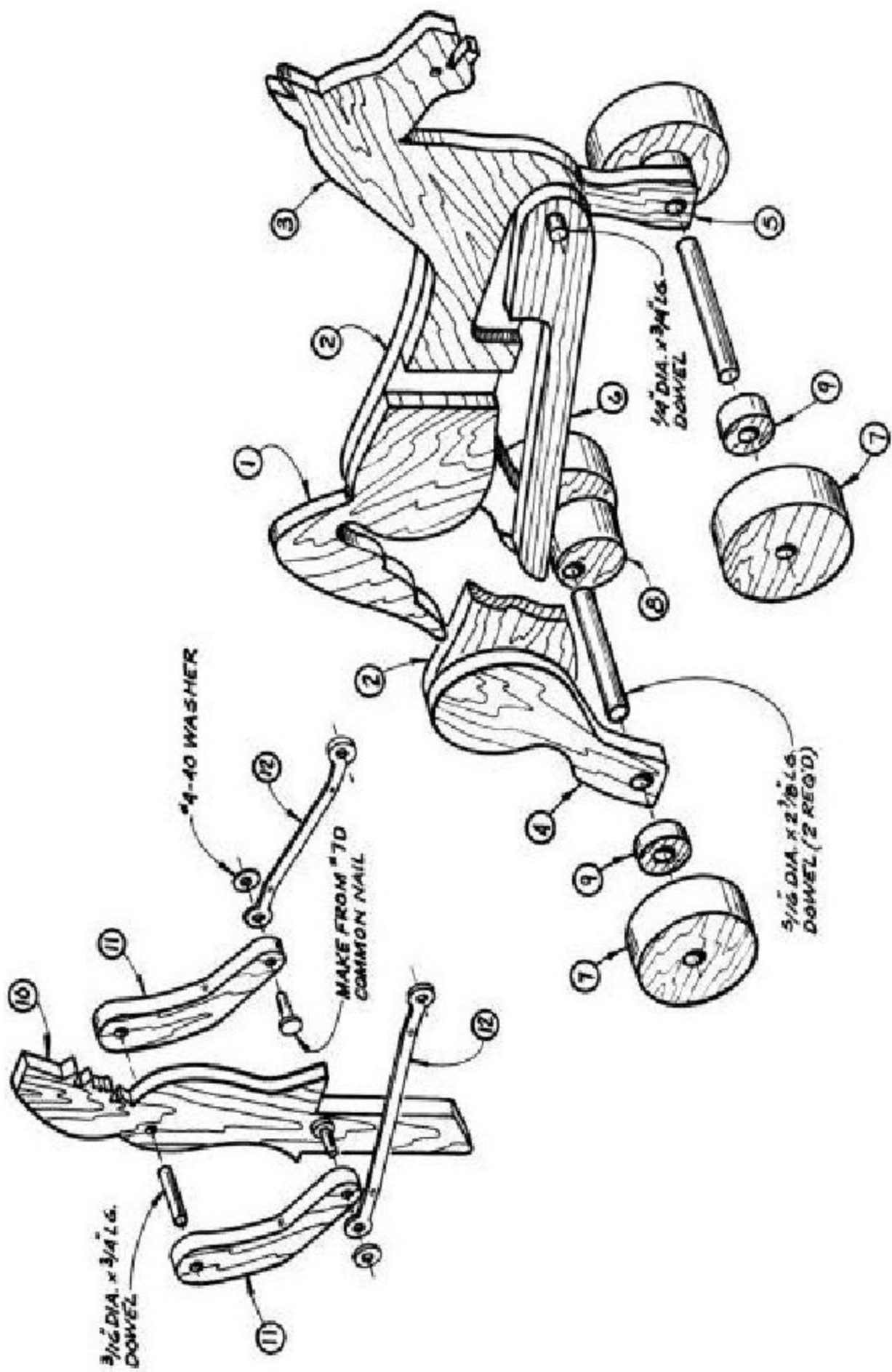

HORSE WITH MOVING RIDER

FULL-SIZE PATTERNS

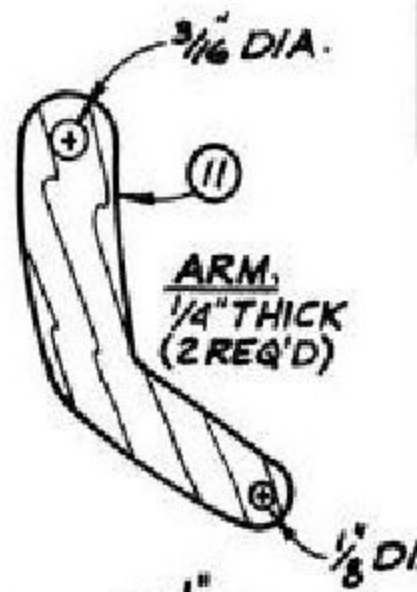

FRONT LEG
1/4" THICK
(2 REQ'D)

5/16" DIA.

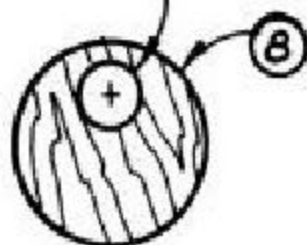

OFF-CENTER DISK
1/2" THICK

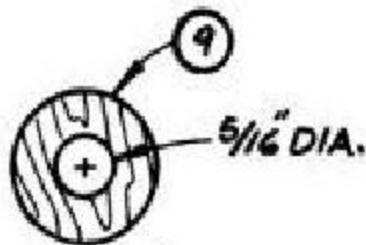

DISK, 1/4" THICK
(4 REQ'D)

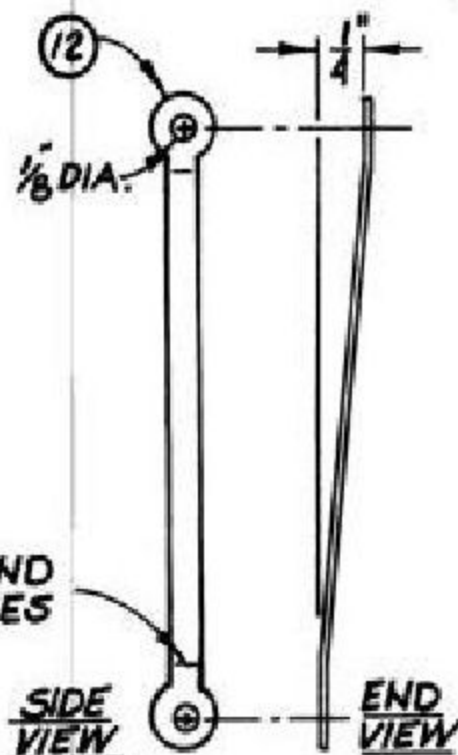

REIN
.020 ALUMINUM
(2 REQ'D)

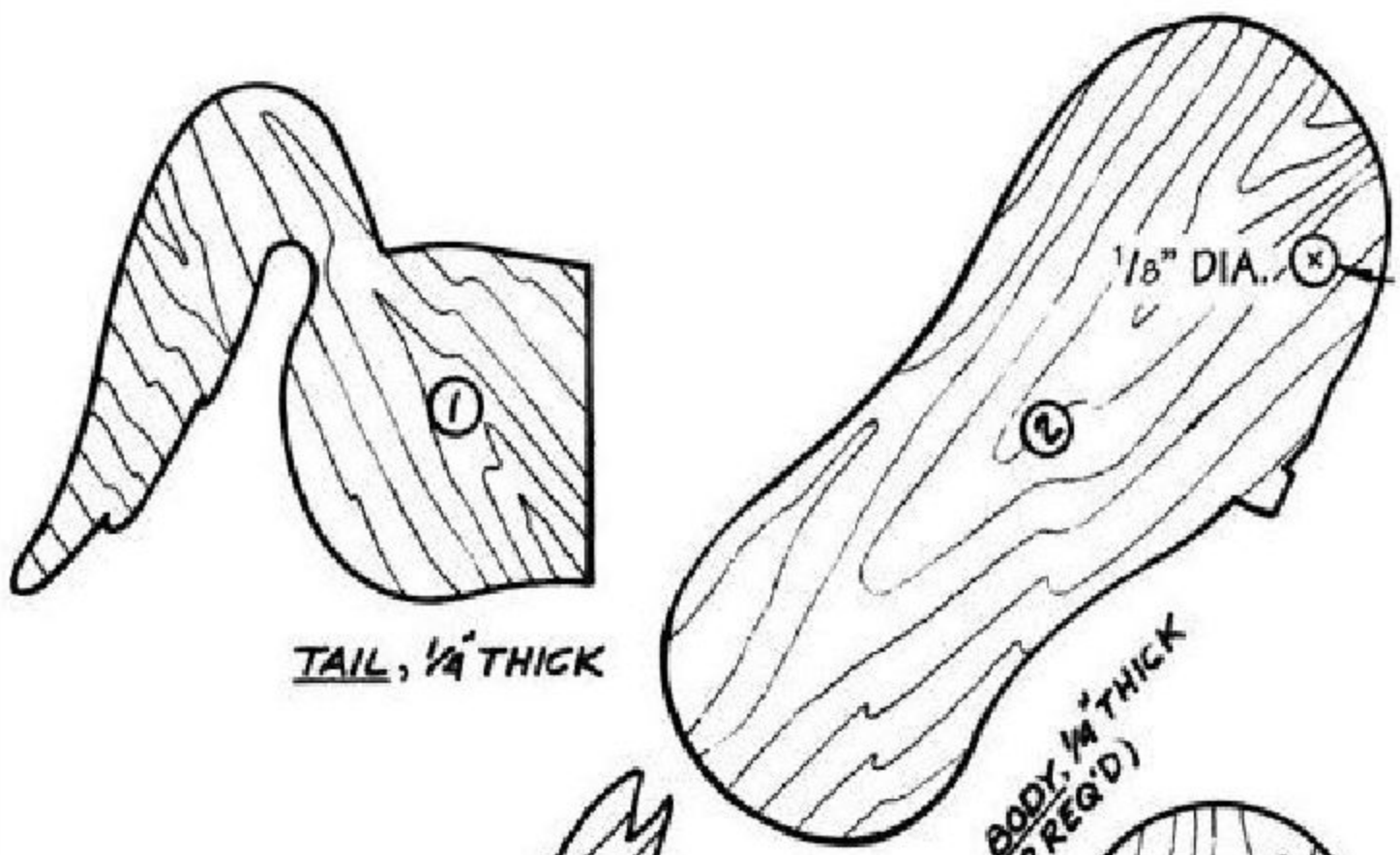

TAIL, 1/4" THICK

BODY, 1/4" THICK
(2 REQ'D)

1/8" DIA. (x)

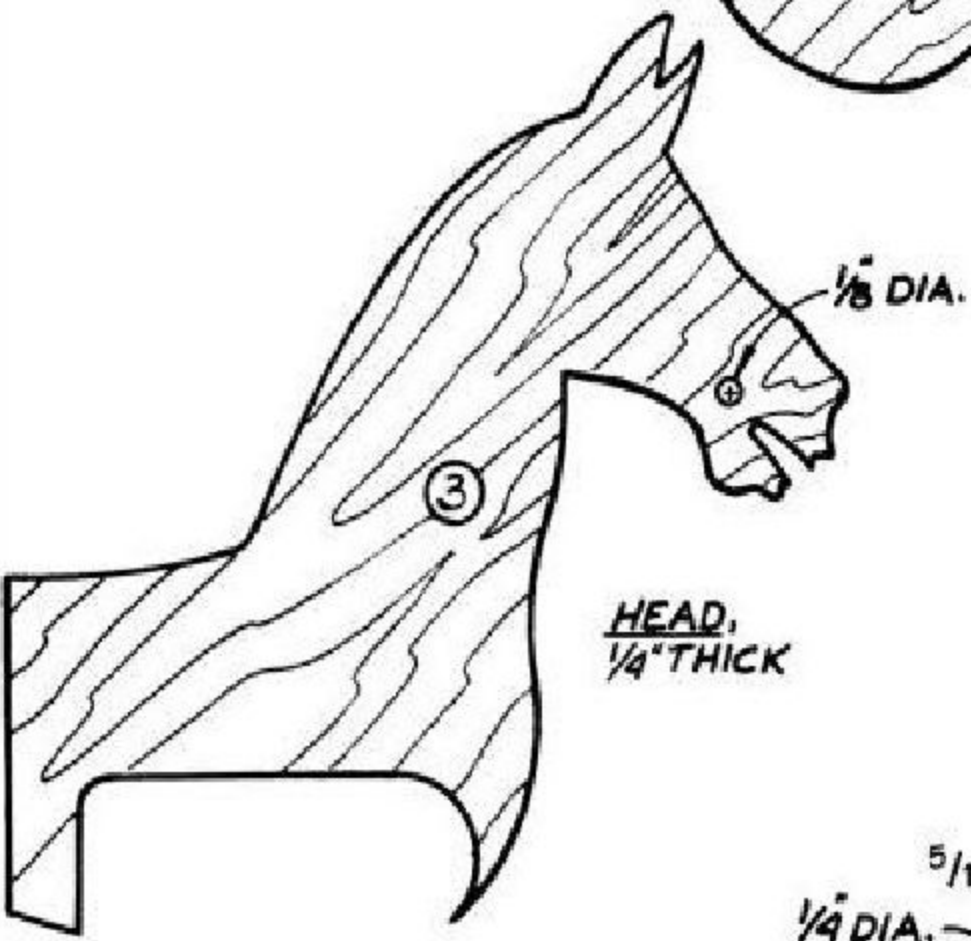

HEAD, 1/4" THICK

1/8" DIA.

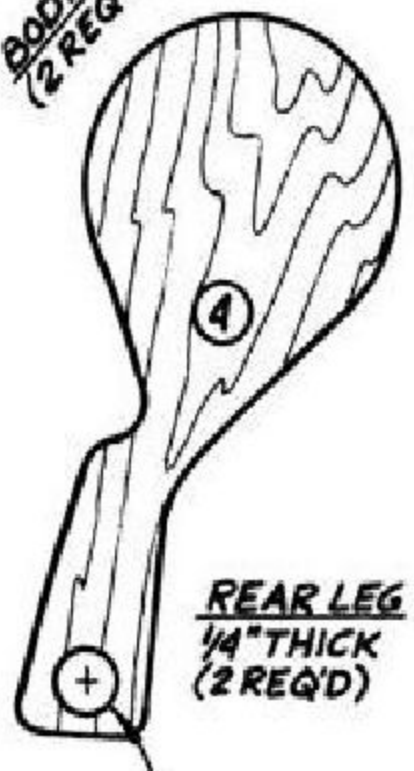

REAR LEG
1/4" THICK
(2 REQ'D)

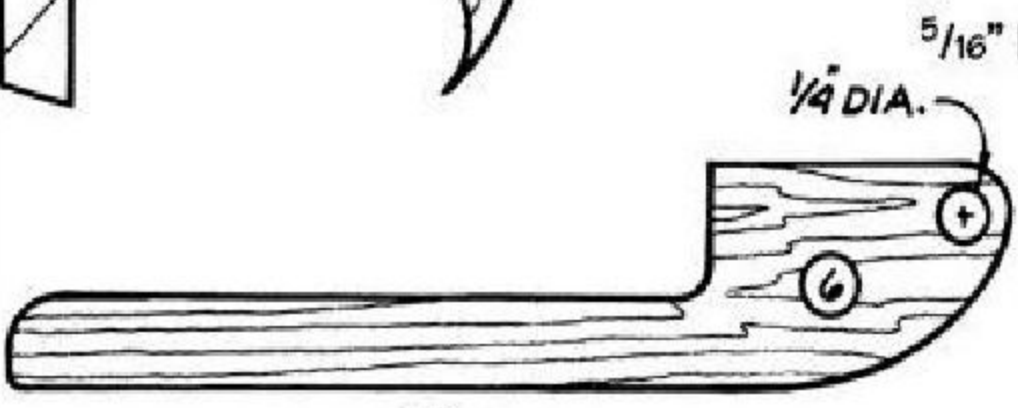

LEVER, 1/4" THICK

1/4" DIA.

5/16" DIA.

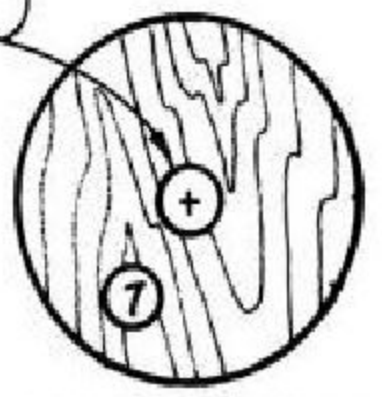

WHEEL, 1/2" THICK
(4 REQ'D)

DIVING FROG

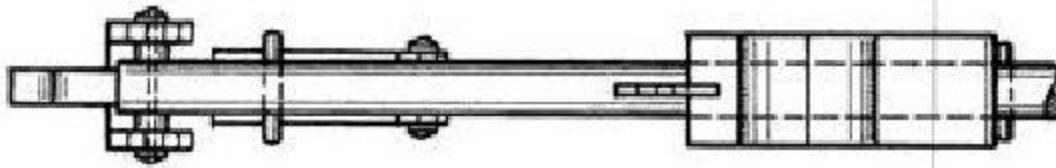

TOY'S ACTION
 MOVE OPERATING ROD TO
 MAKE THE FROG DIVE FOR
 THE BUG

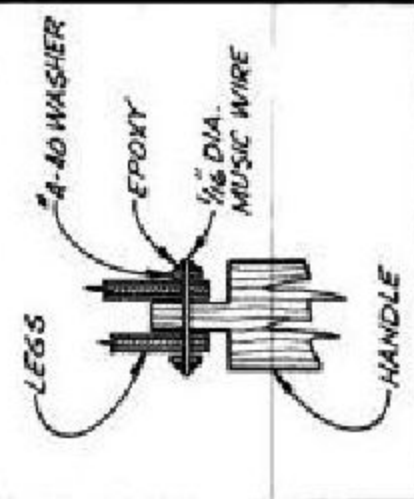
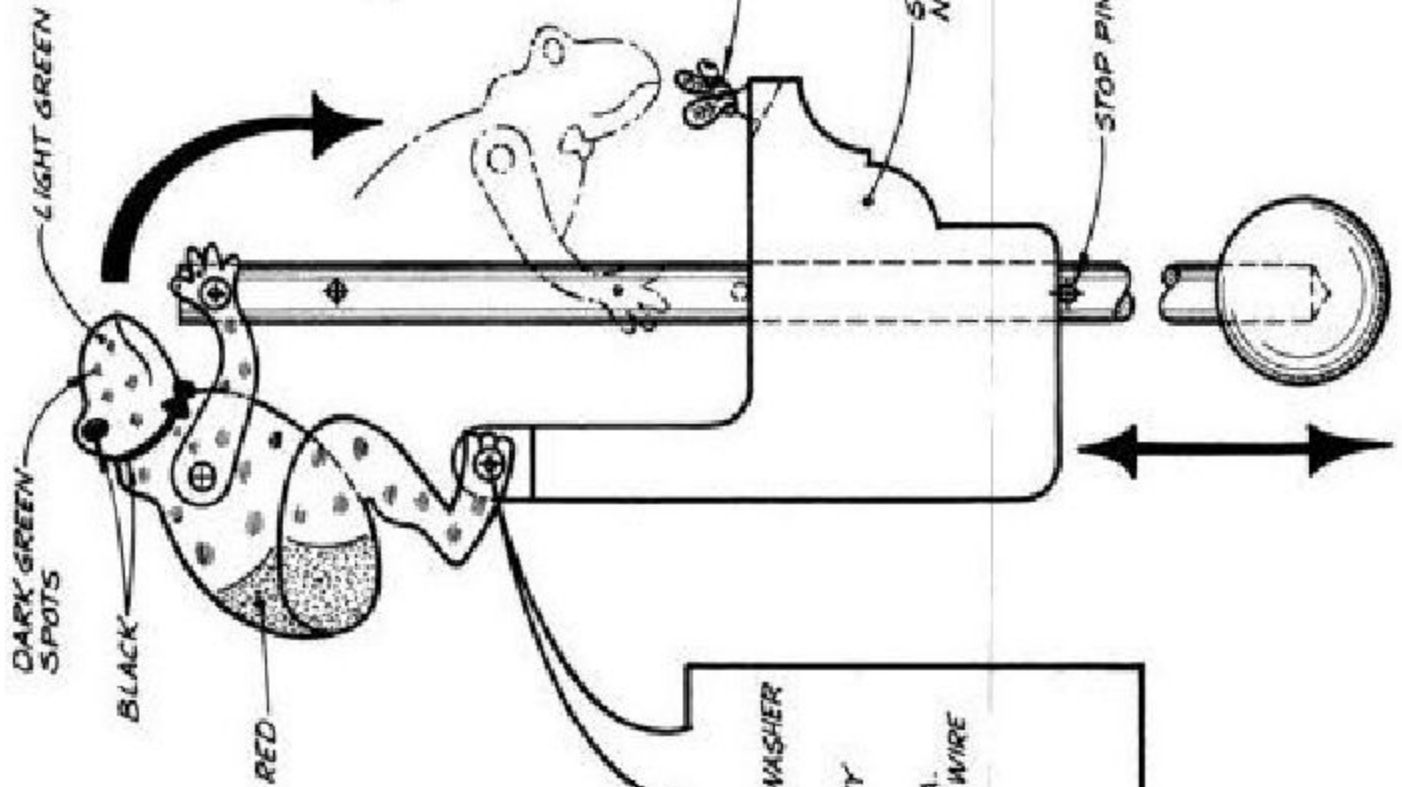

PIVOT DETAIL

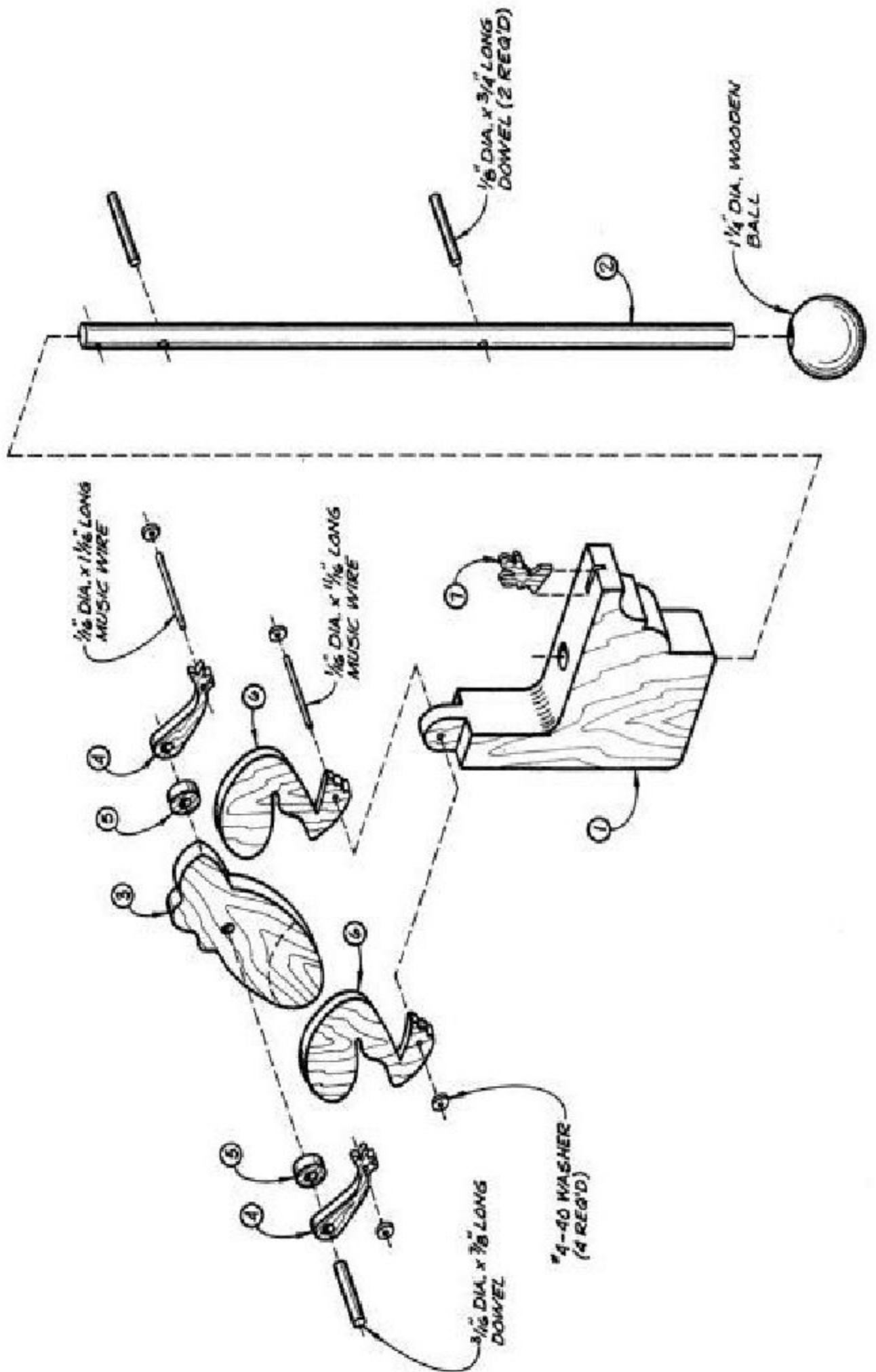

DIVING FROG

FULL-SIZE PATTERNS

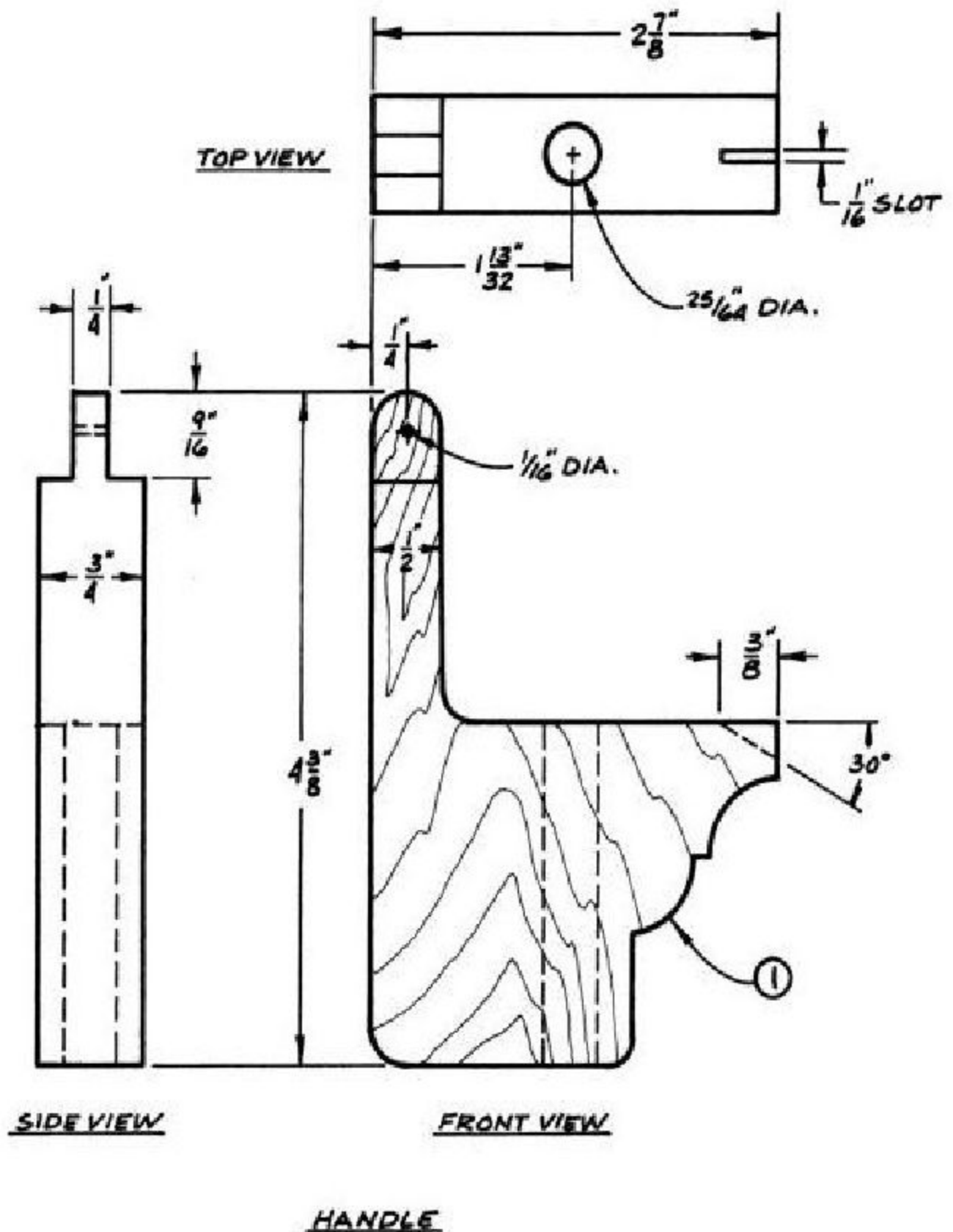

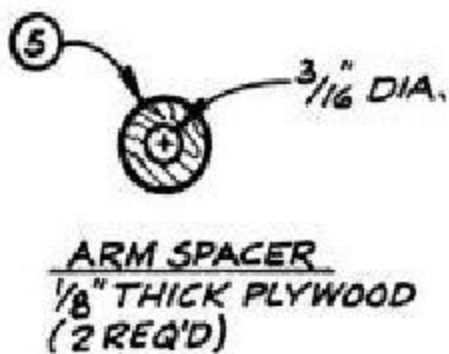
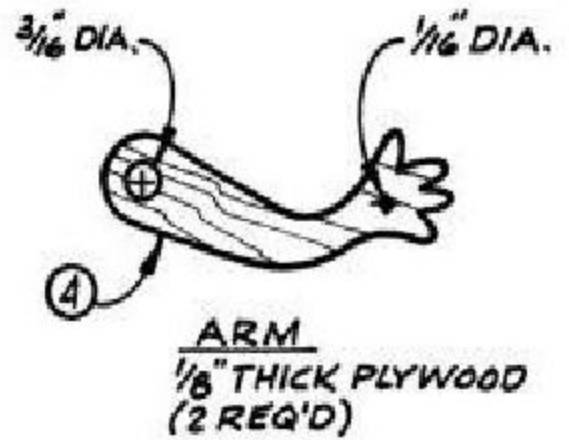
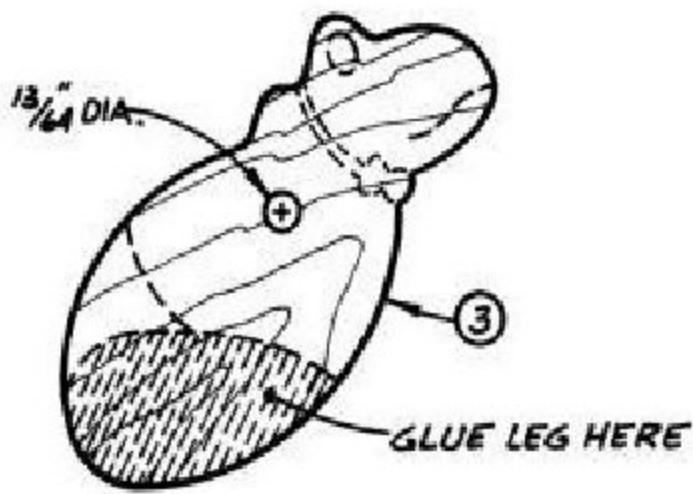
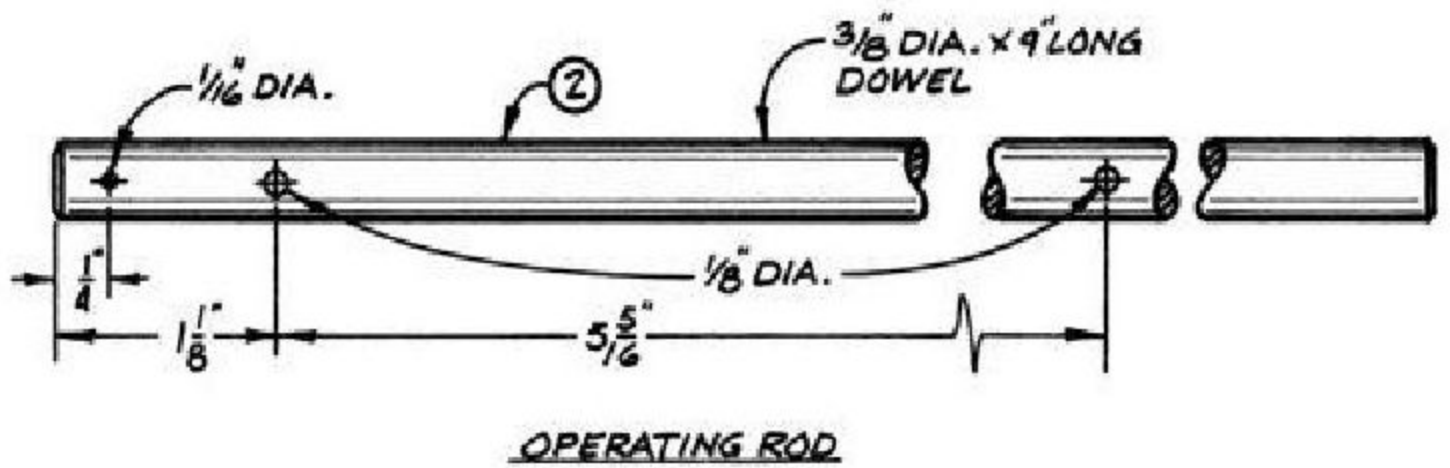

WALKING PIG

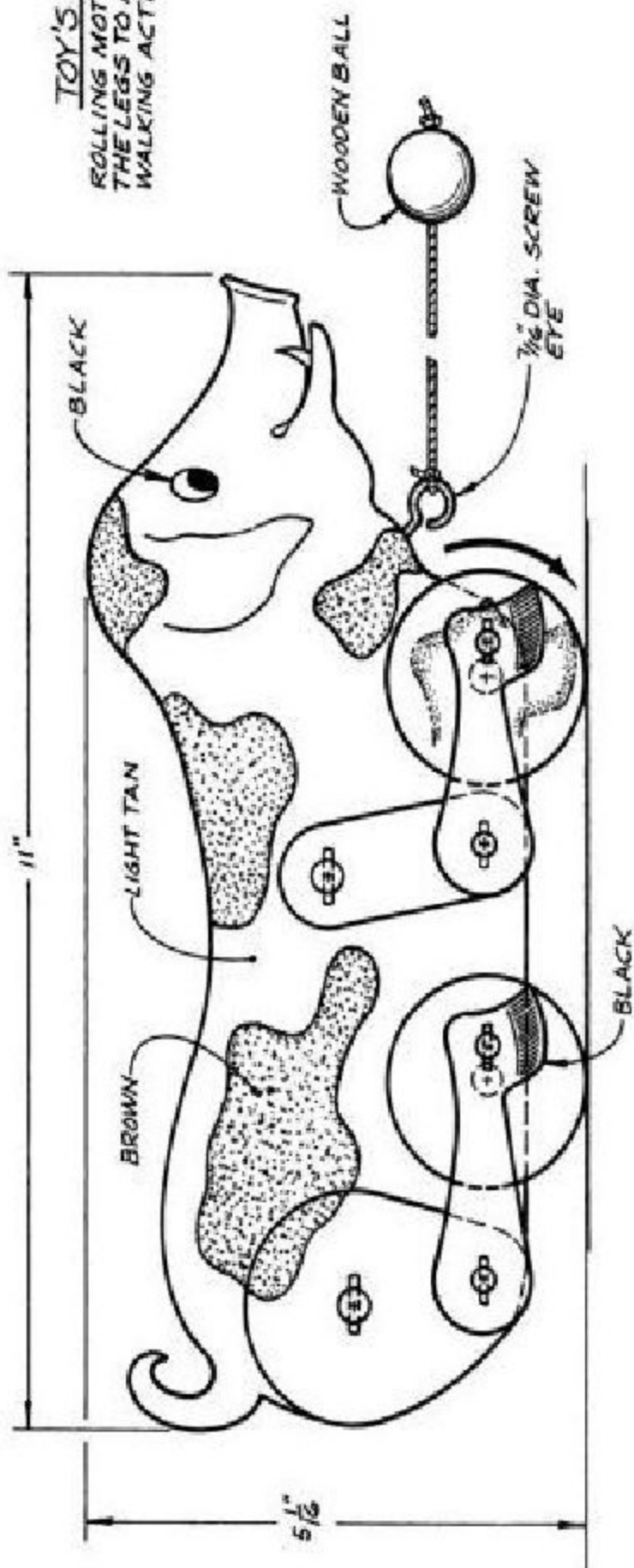
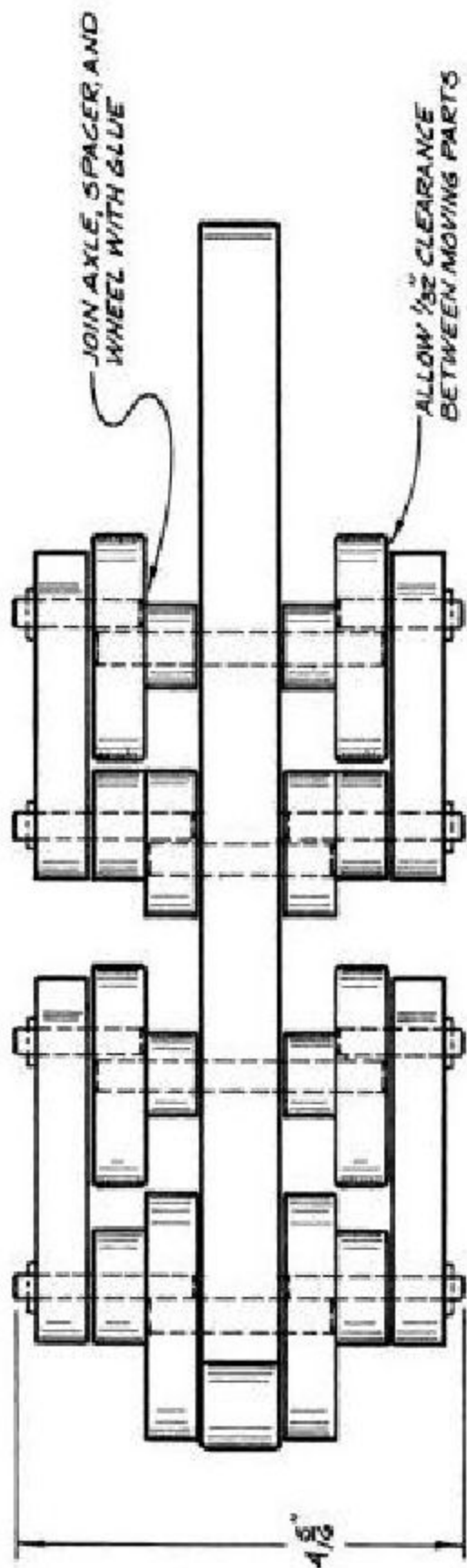

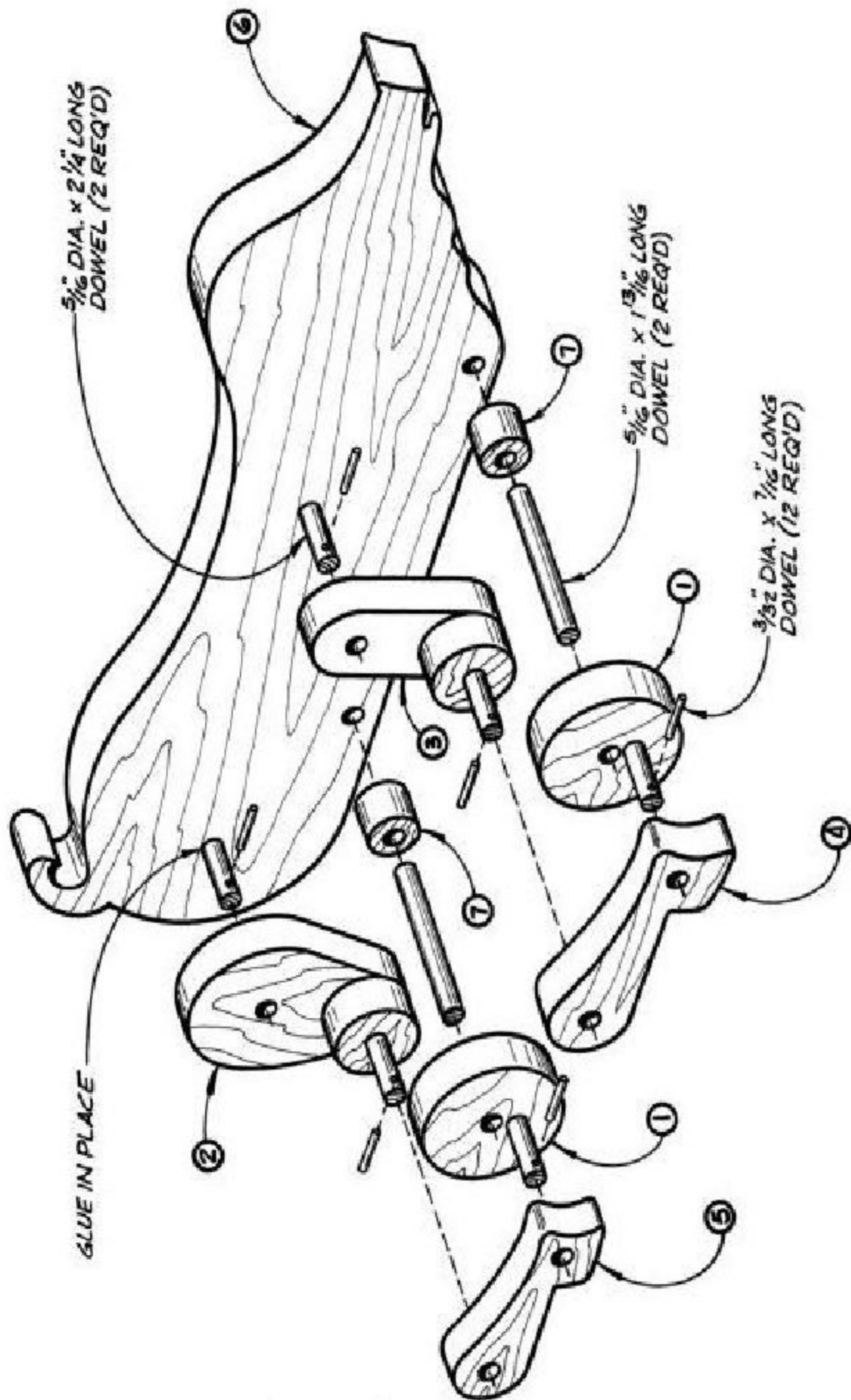

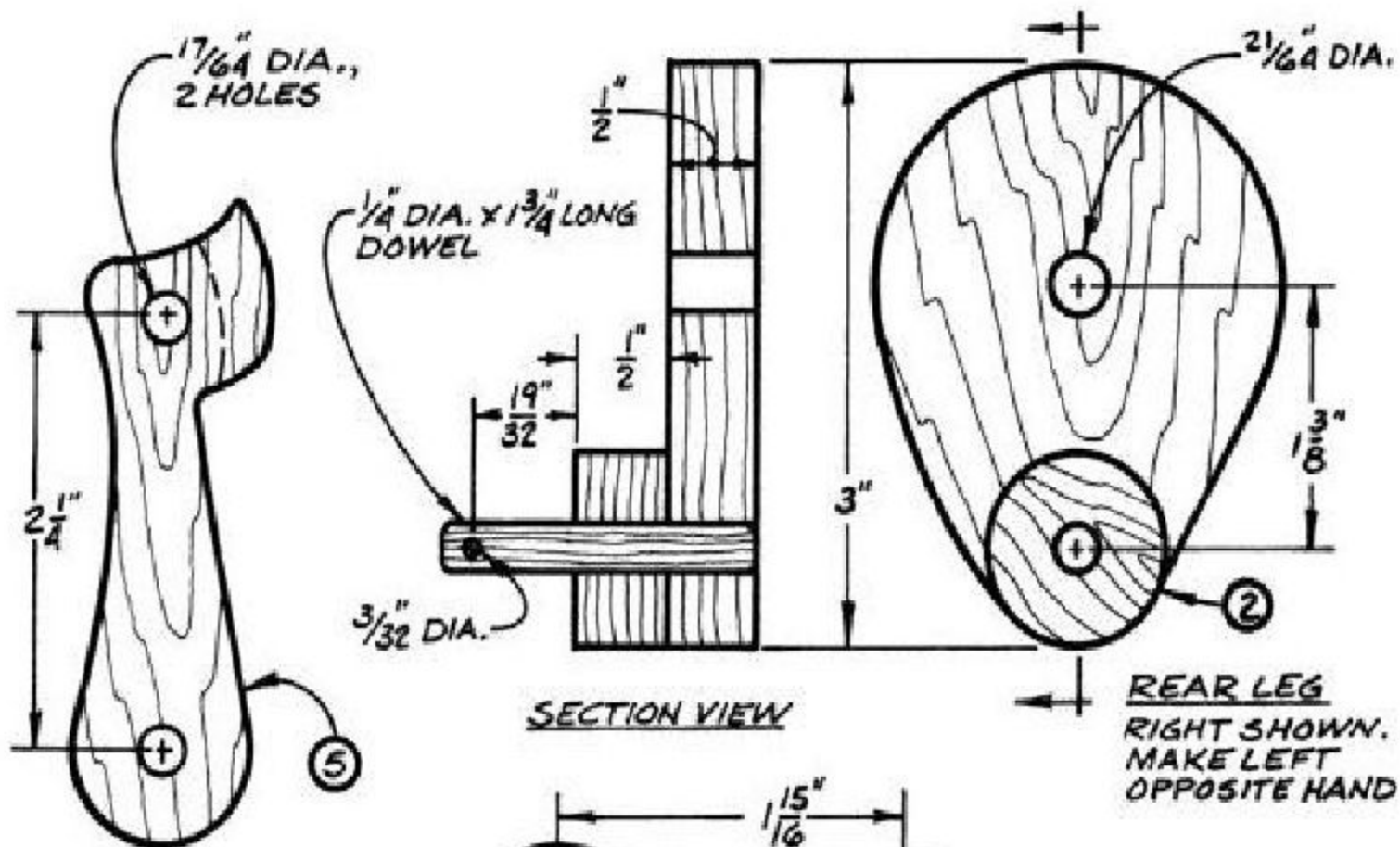

REAR LEG
1/2" THICK (2 REQ'D)

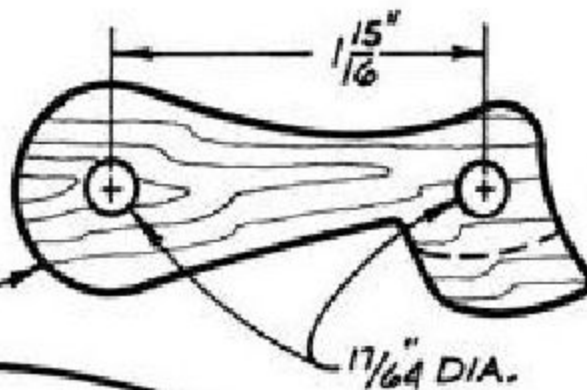

FRONT LEG
1/2" THICK (2 REQ'D)

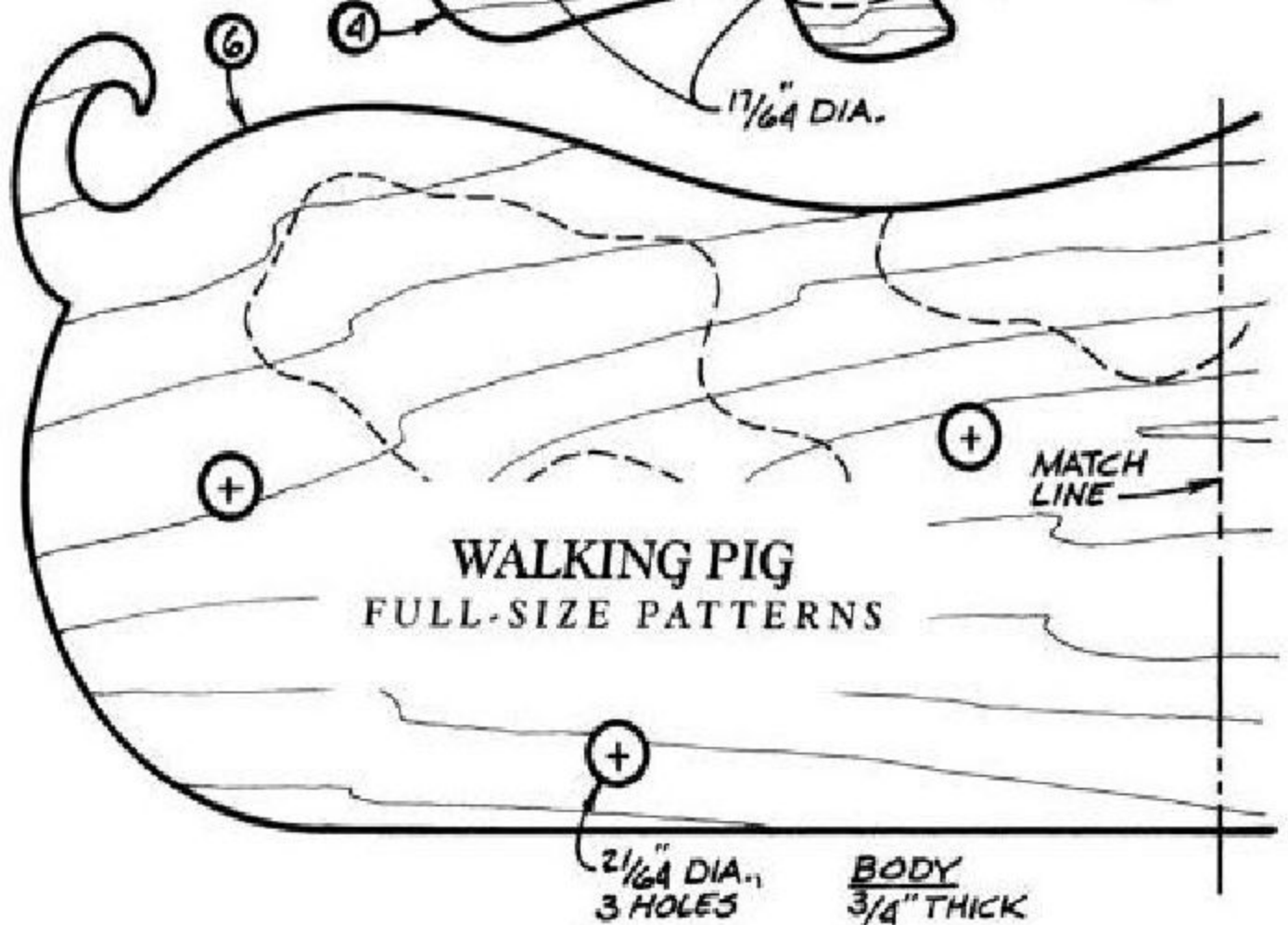

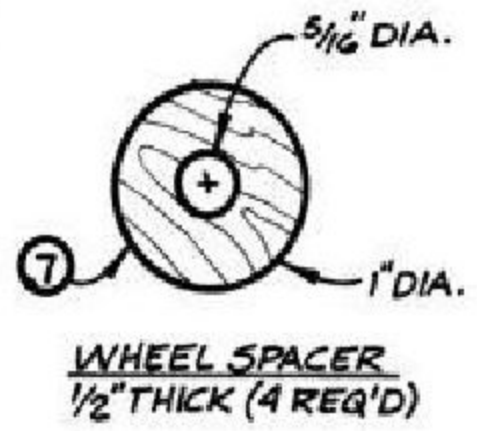
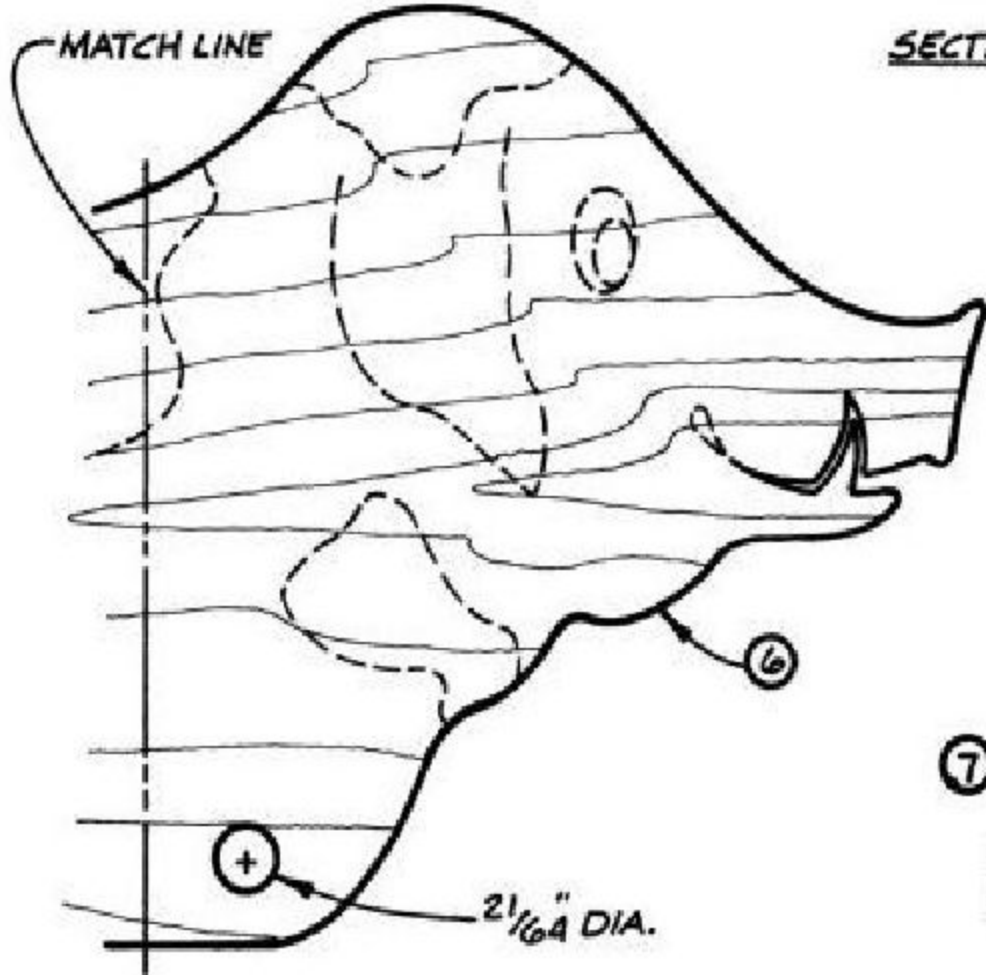
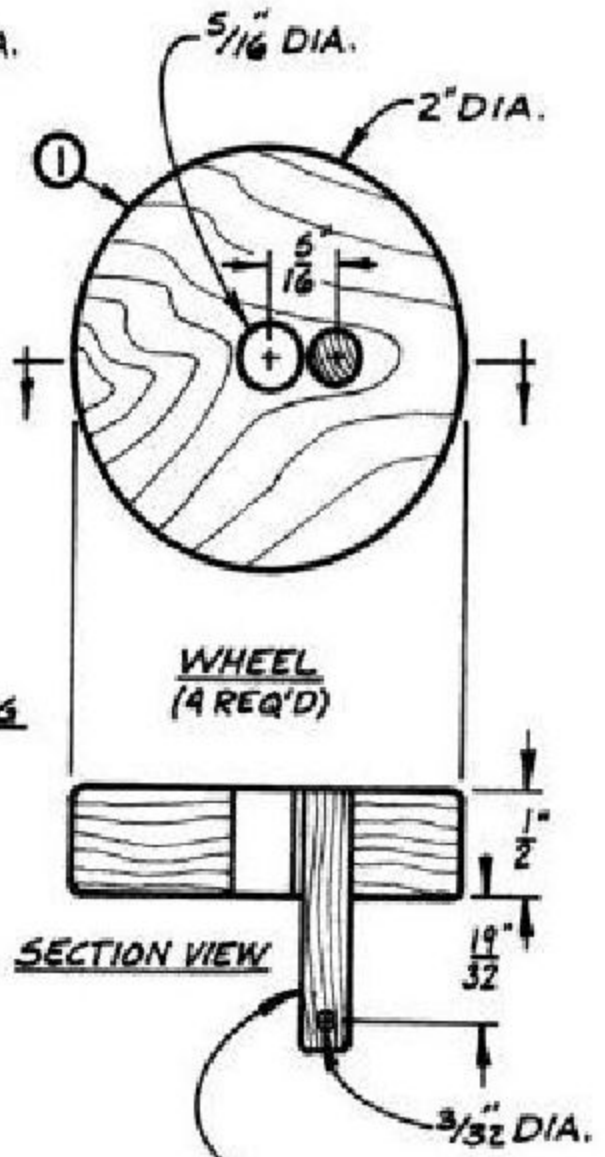
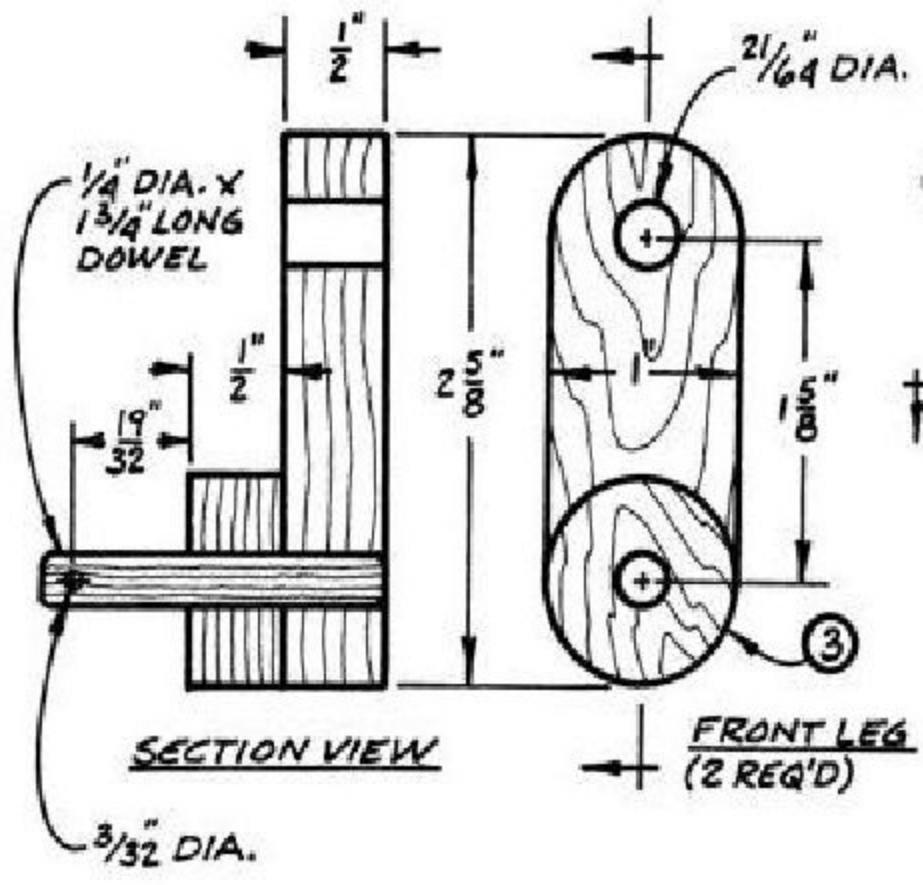

COURT JESTER

TOY'S ACTION

THE JESTER WILL SEEM TO MAGICALLY CLING TO THE EDGE OF A TABLE OR THE STAND AS HE ROCKS BACK AND FORTH

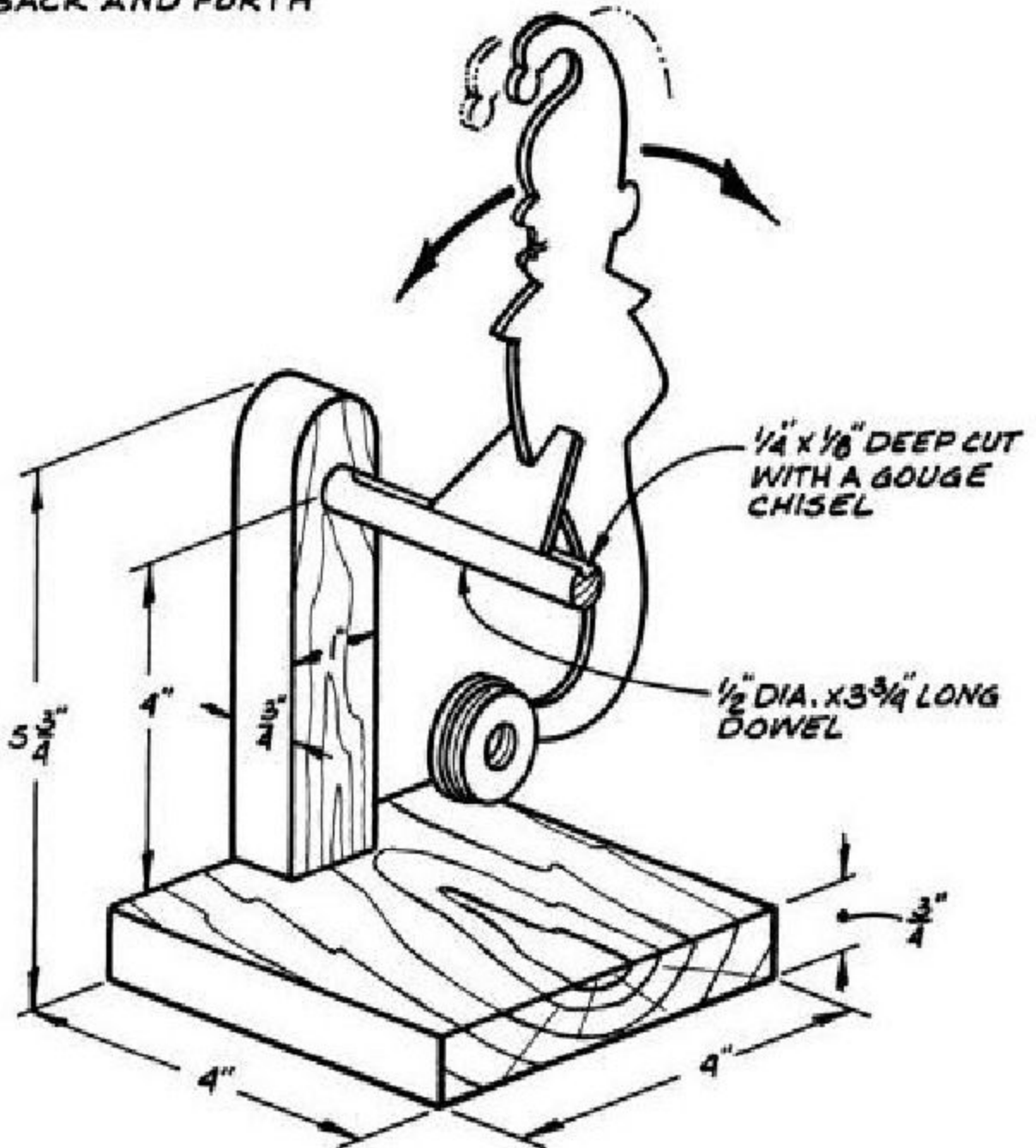

STAND

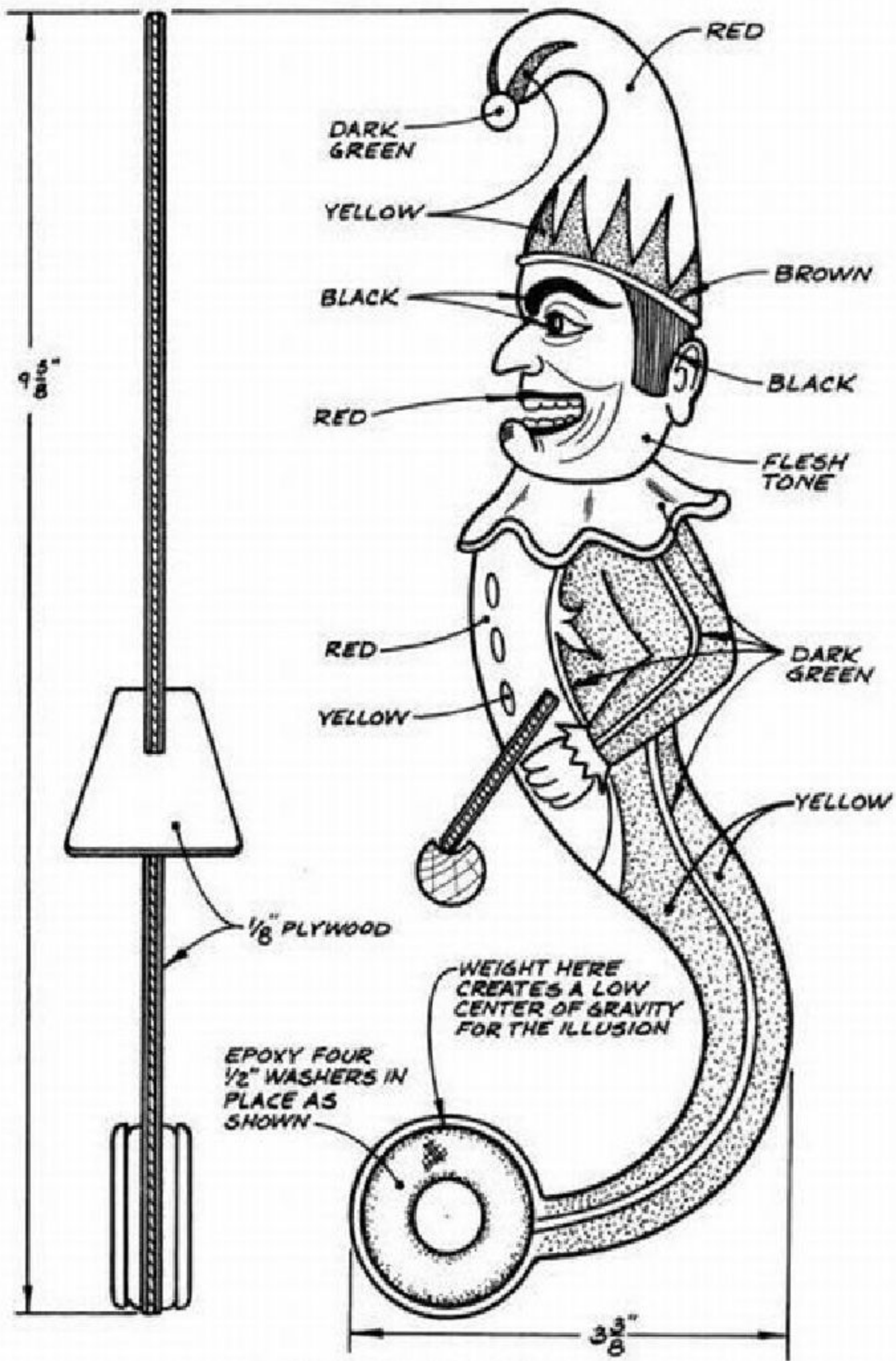

FULL-SIZE PATTERN

WALKING RABBIT

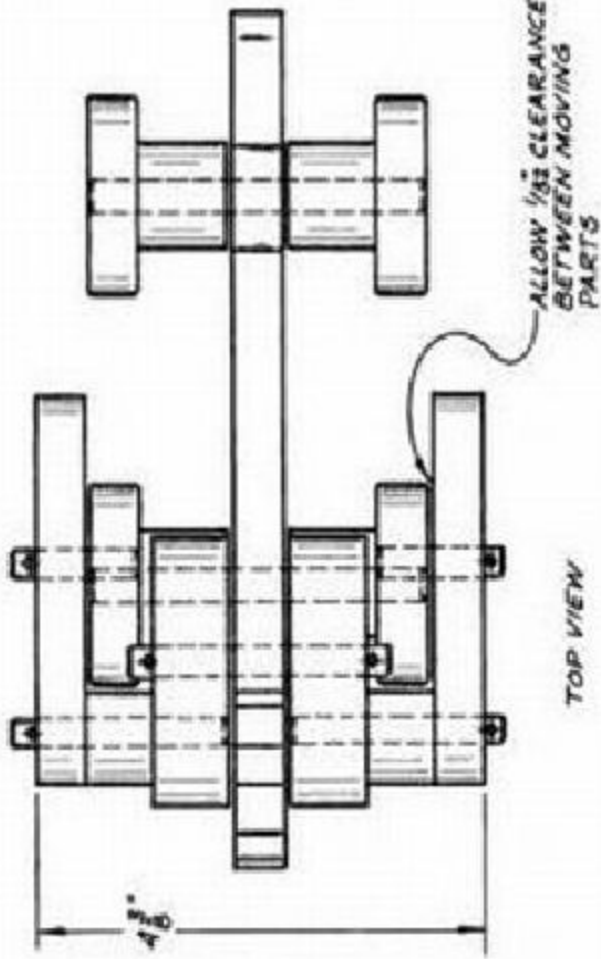
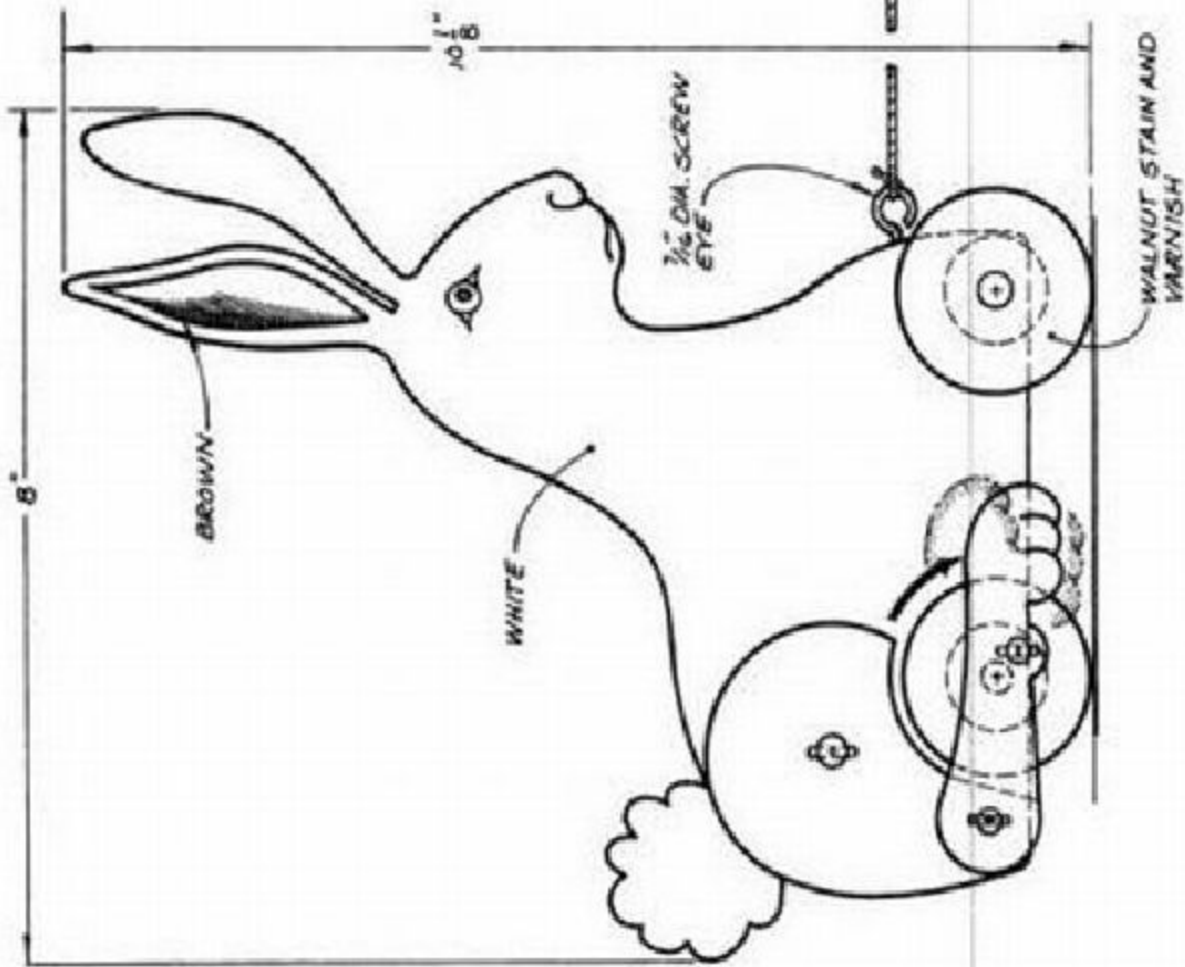

TOY'S ACTION
 ROLLING MOTION CAUSES
 THE LEGS TO MOVE WITH
 A WALKING ACTION

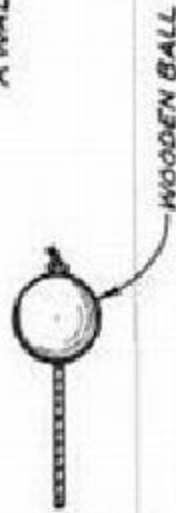

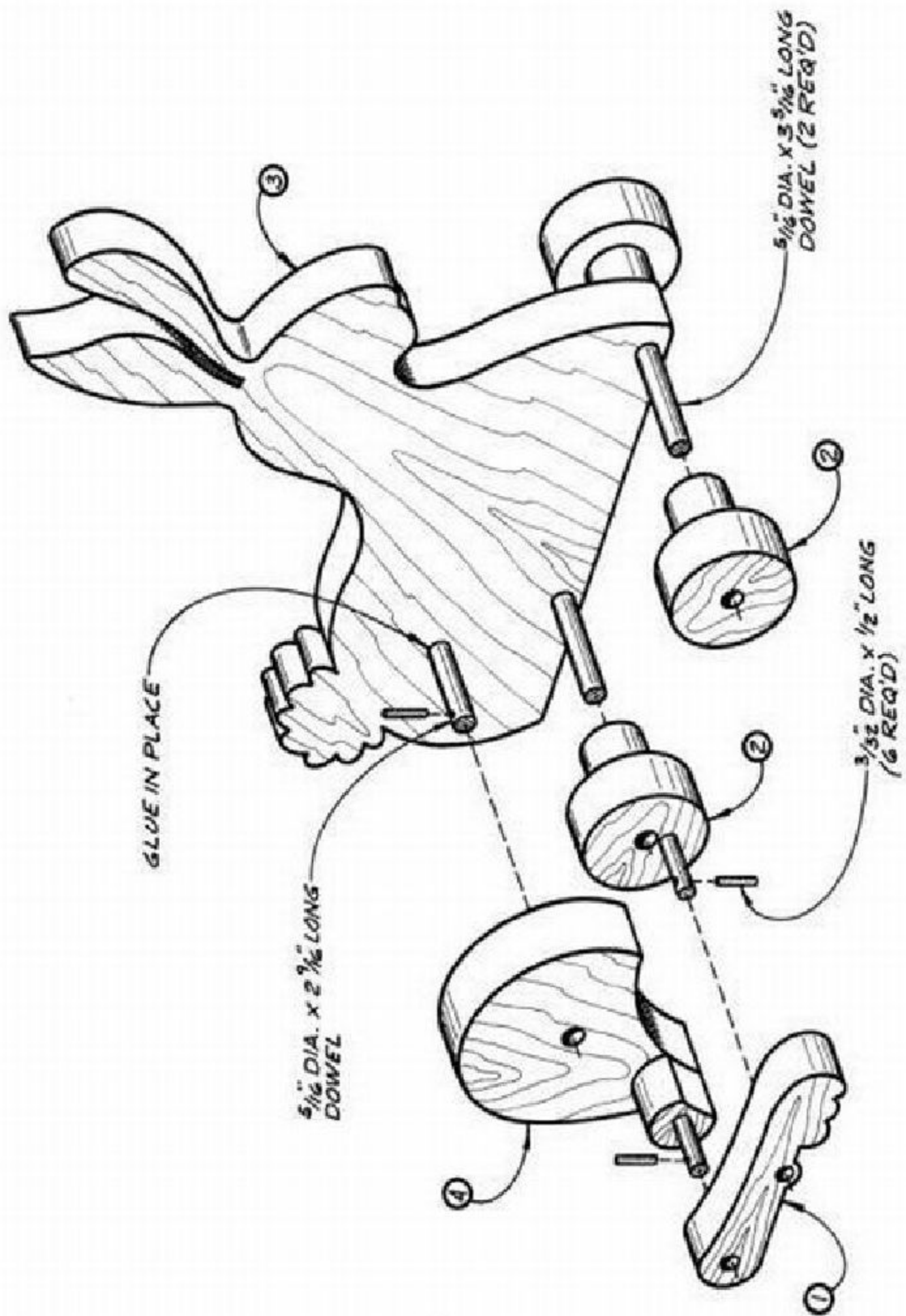

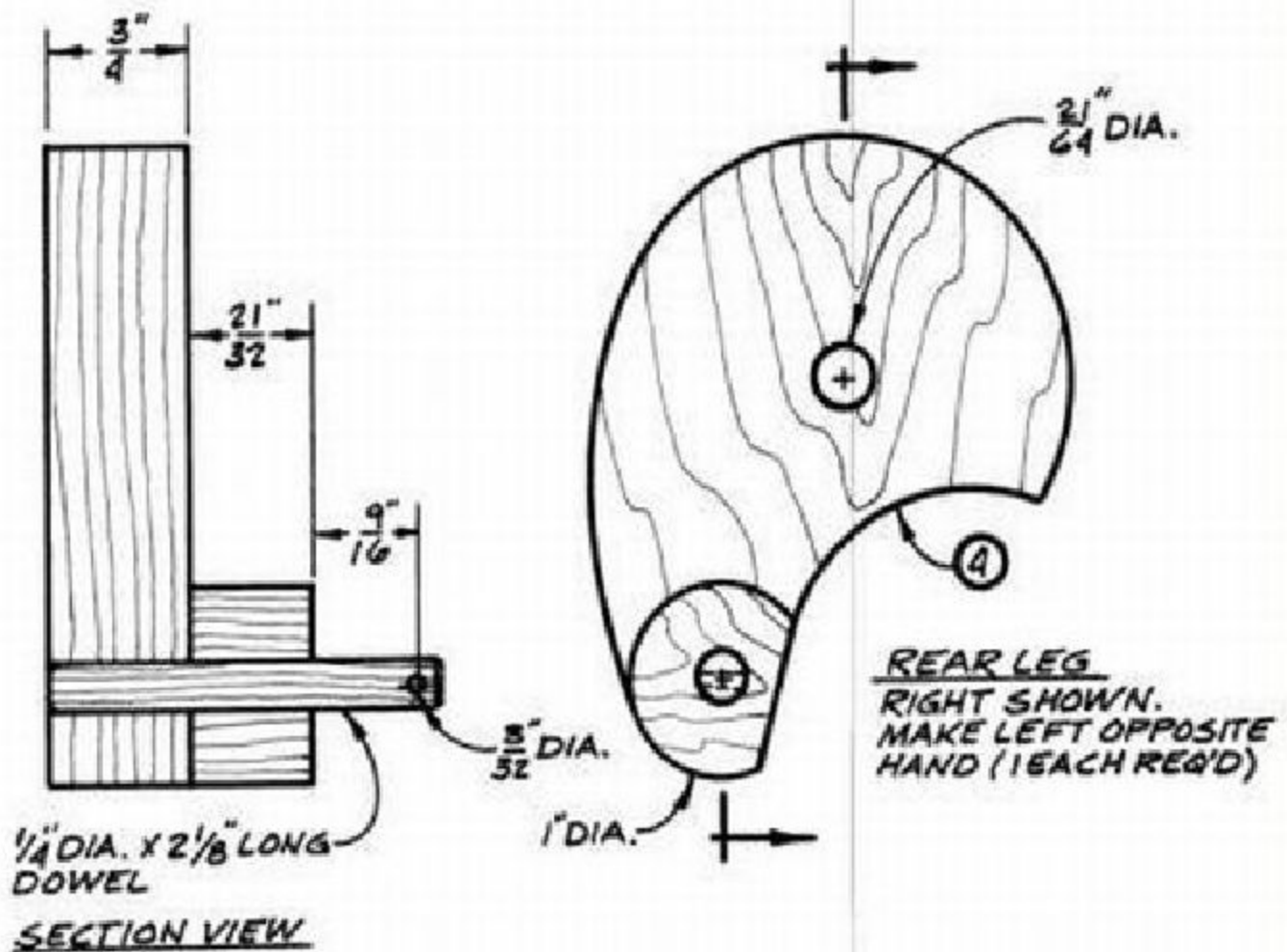
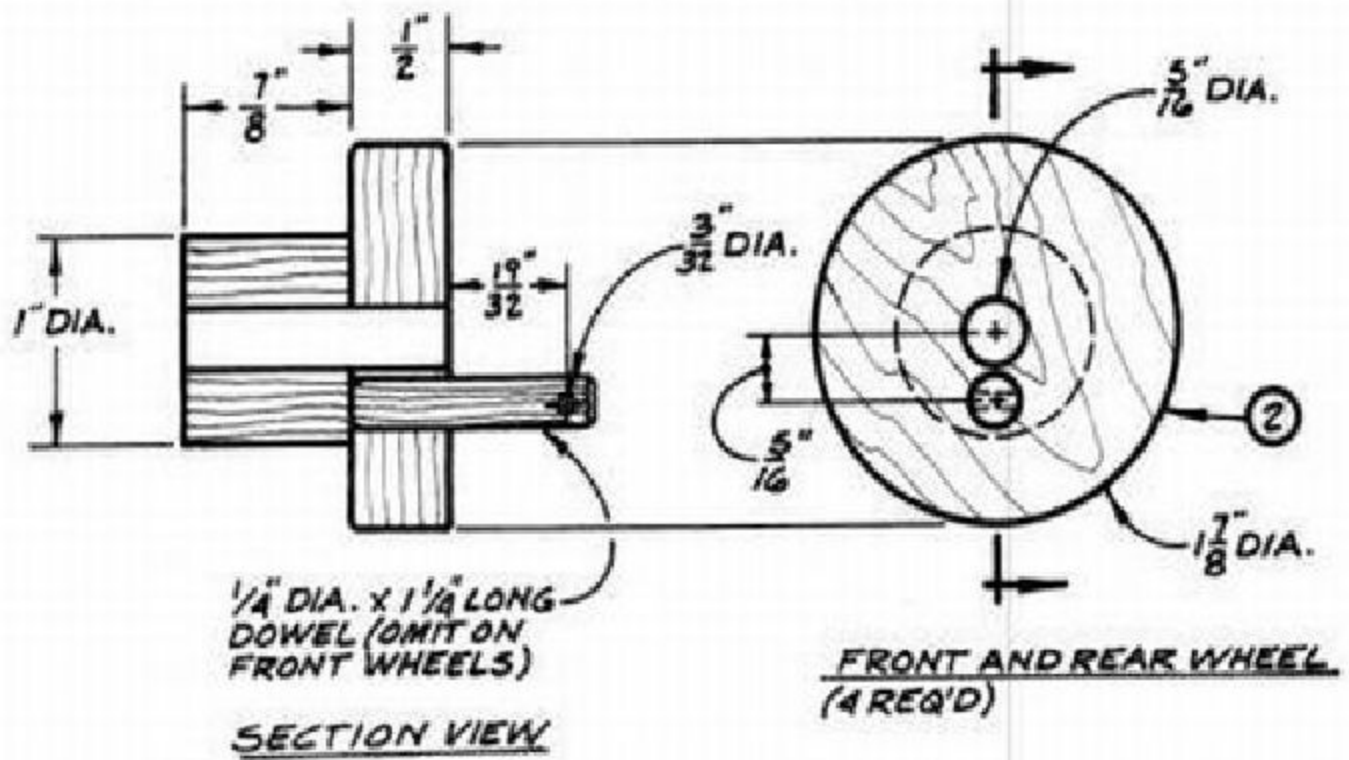

WALKING RABBIT
FULL-SIZE PATTERNS

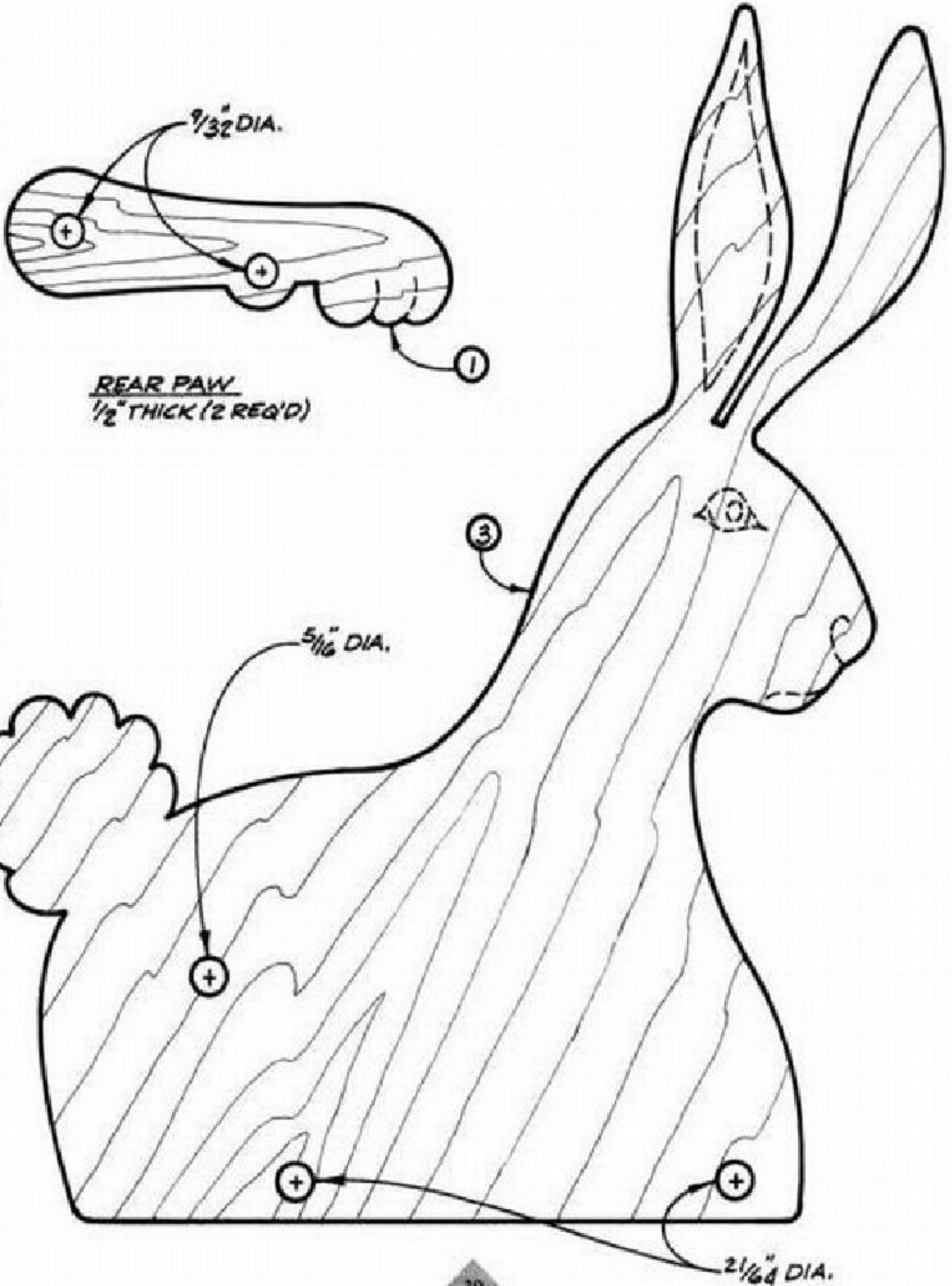

HINGED CROCODILE

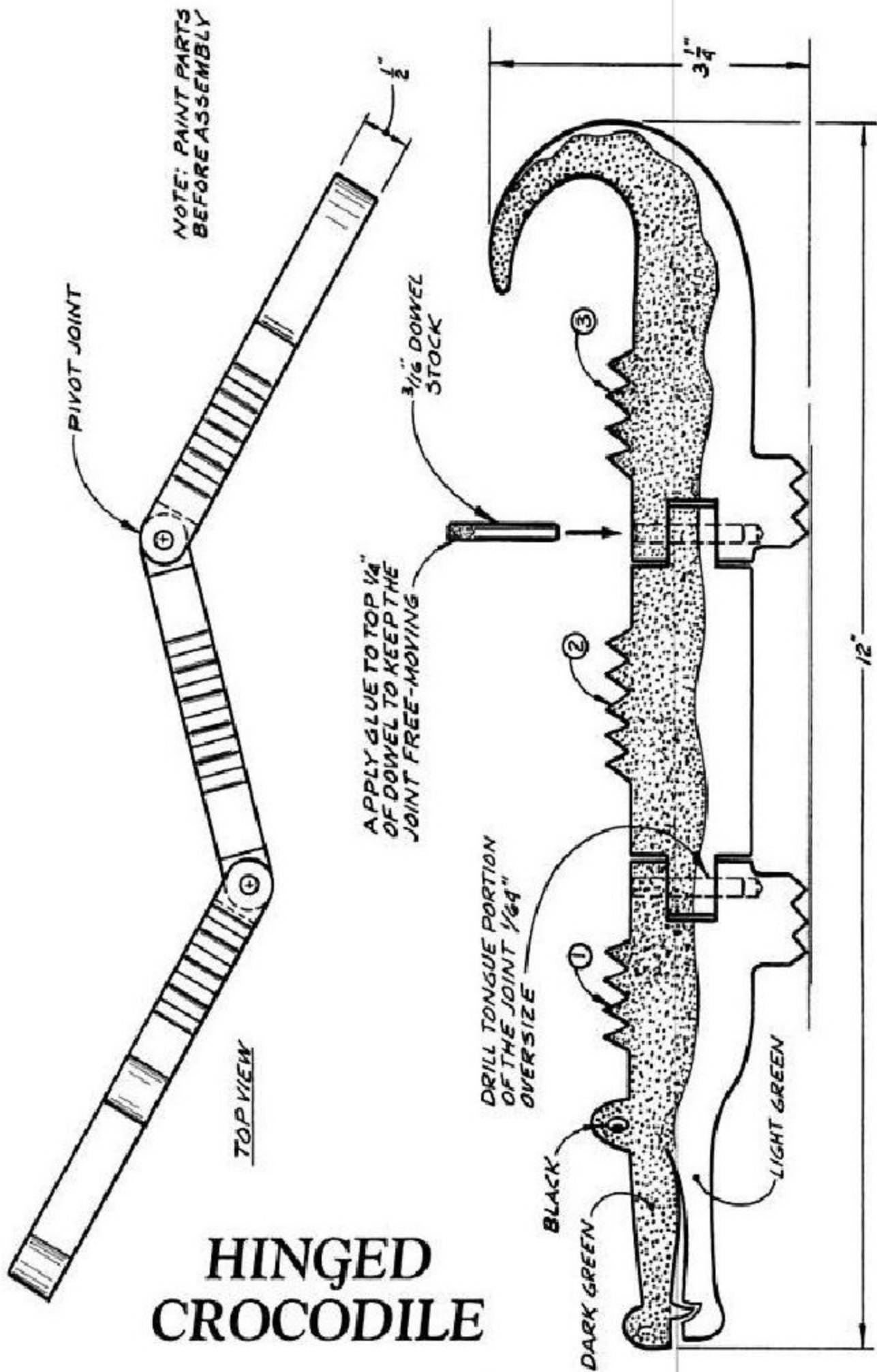

FULL-SIZE PATTERNS

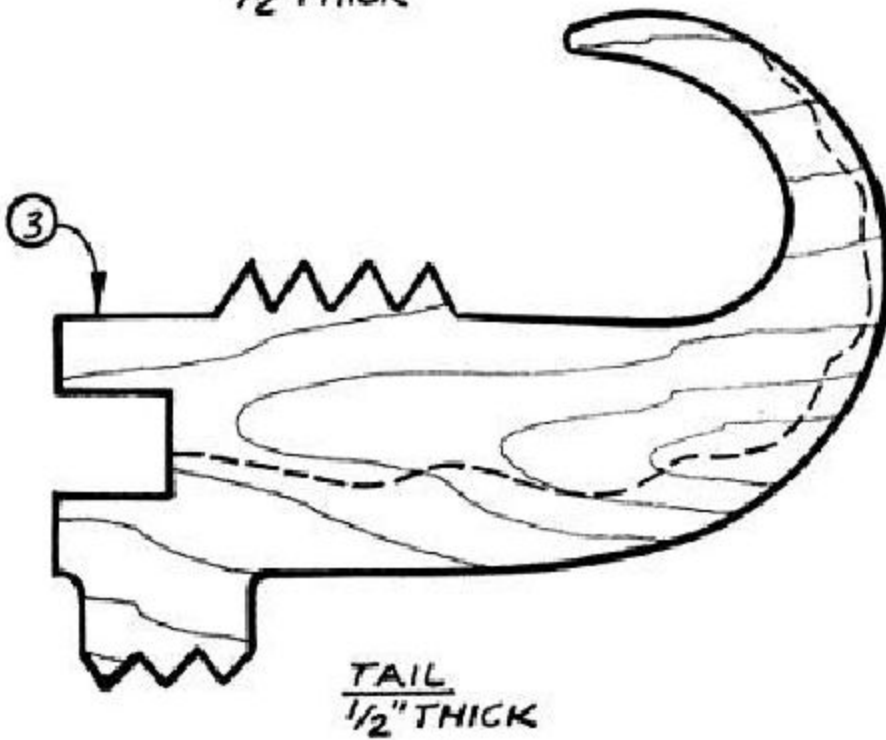
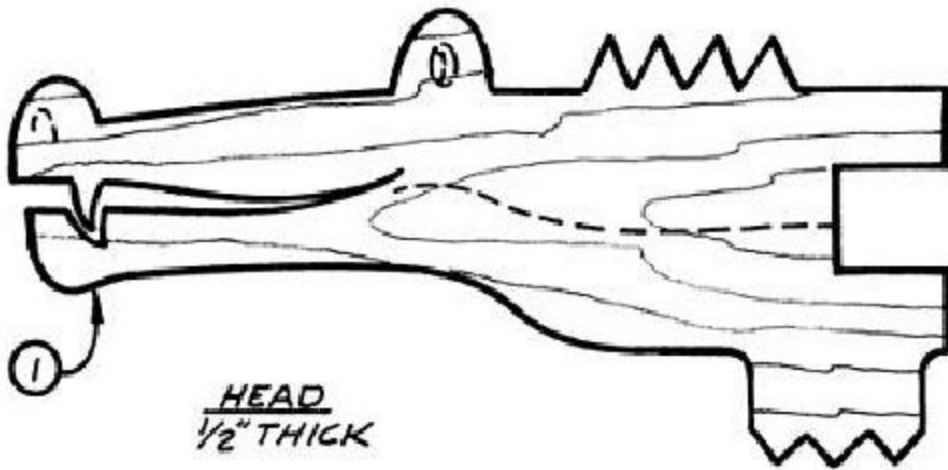

LADY AND HER FLOCK

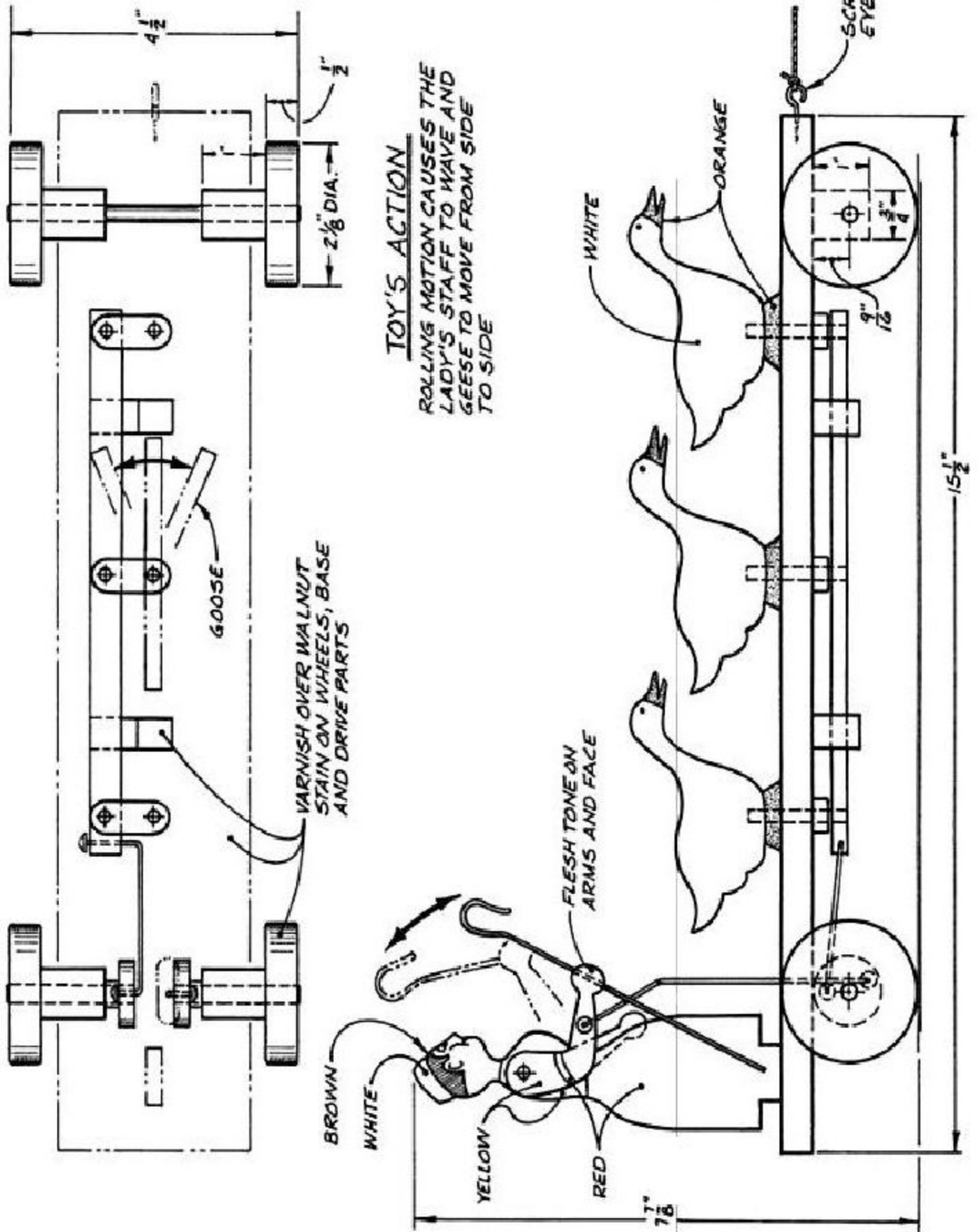

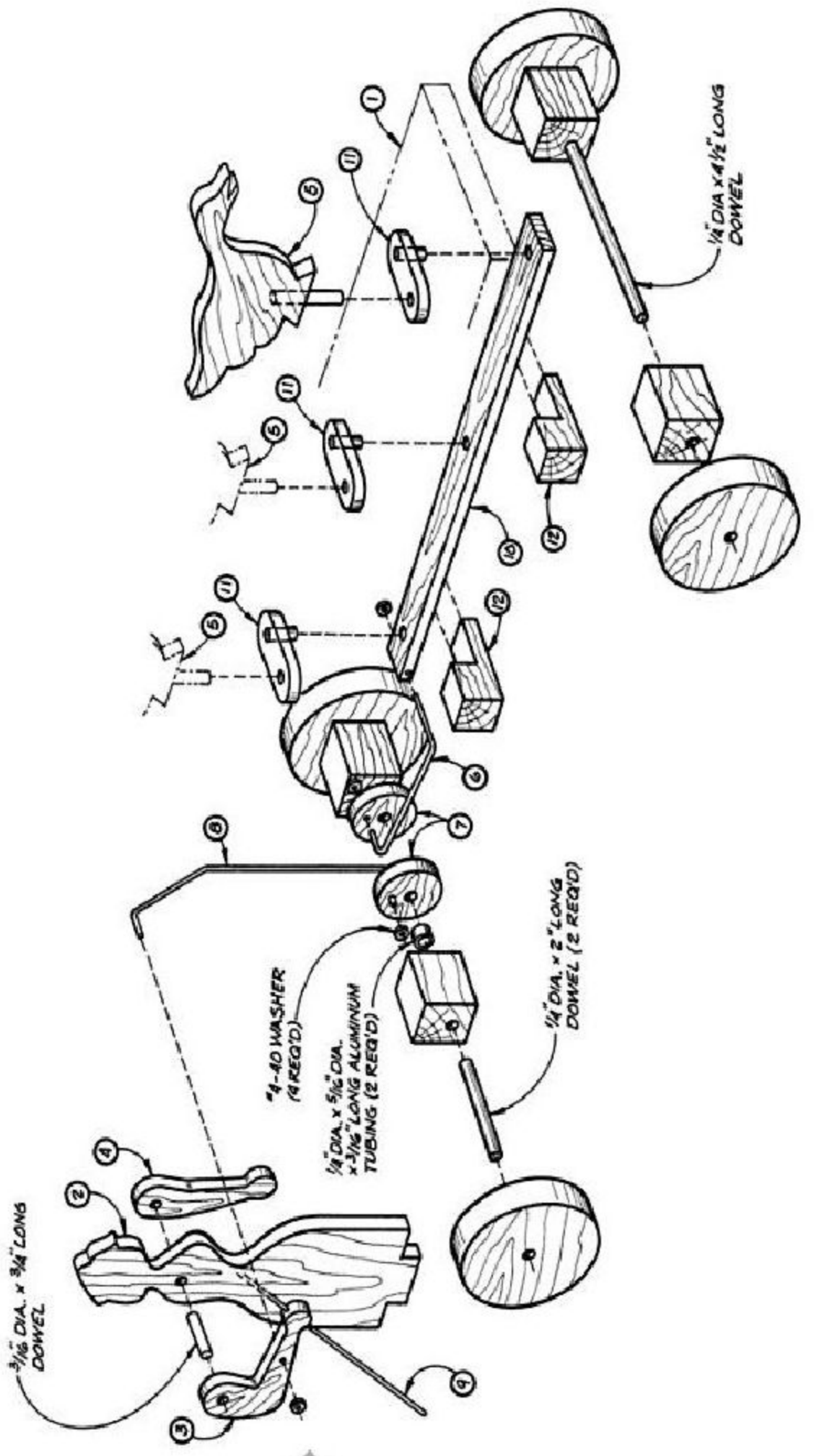

LADY AND HER FLOCK FULL-SIZE PATTERNS

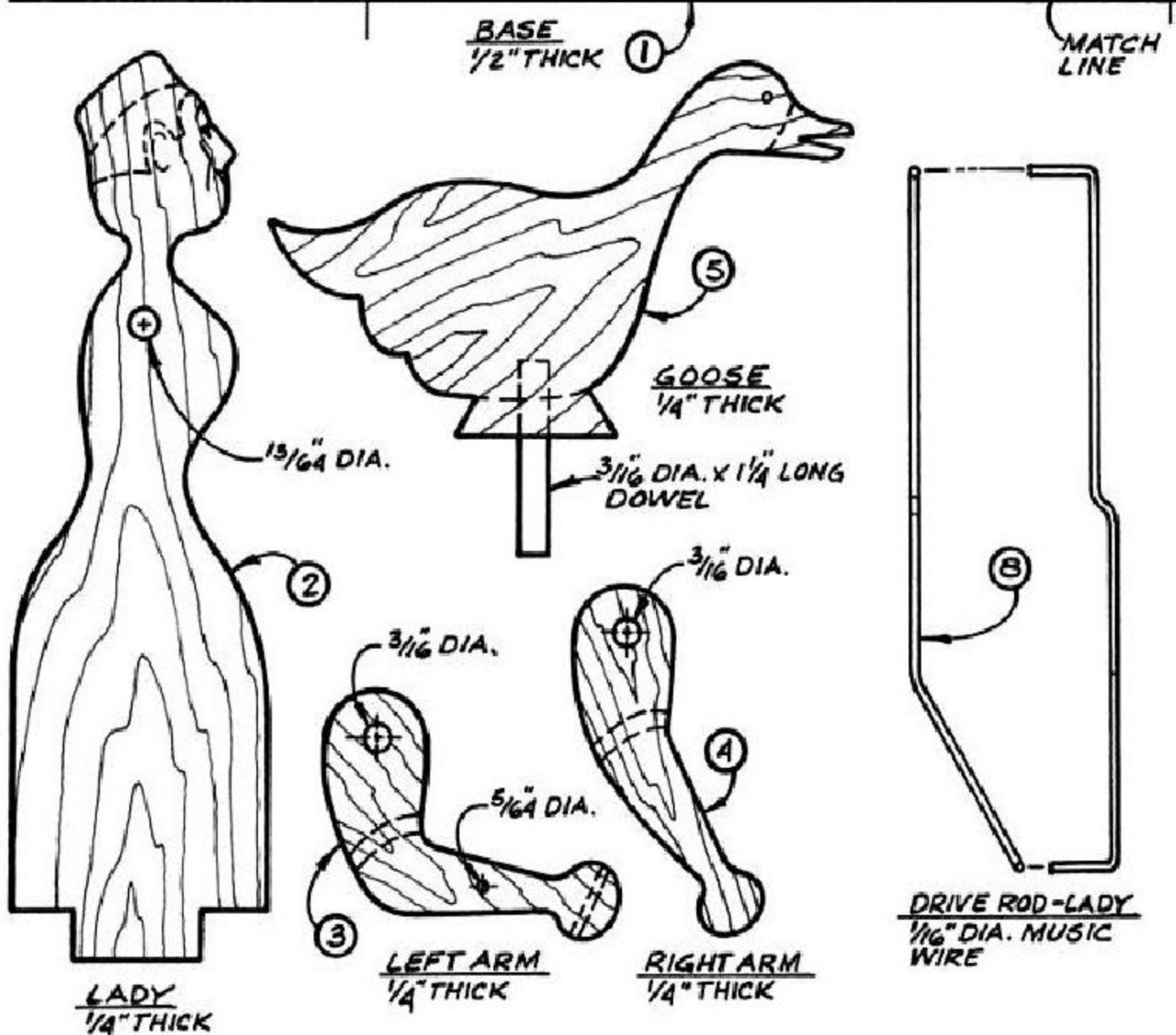
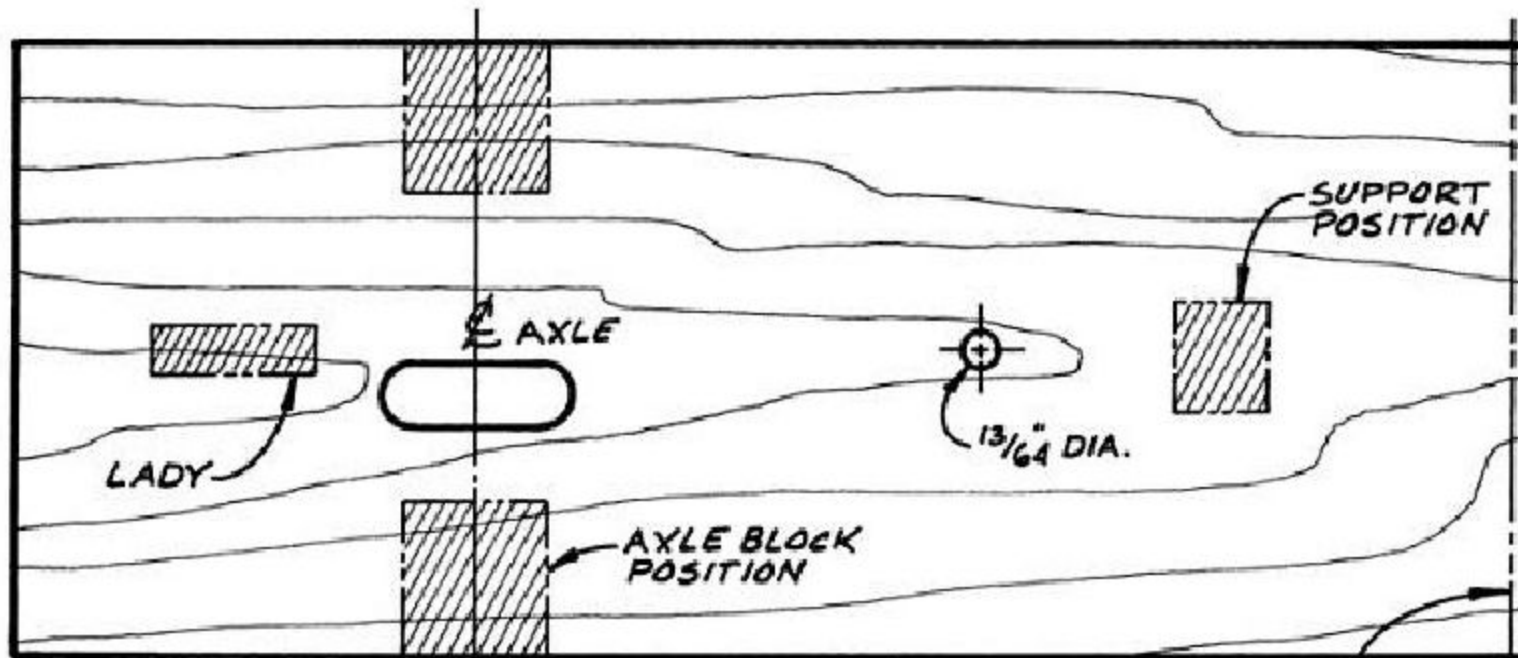

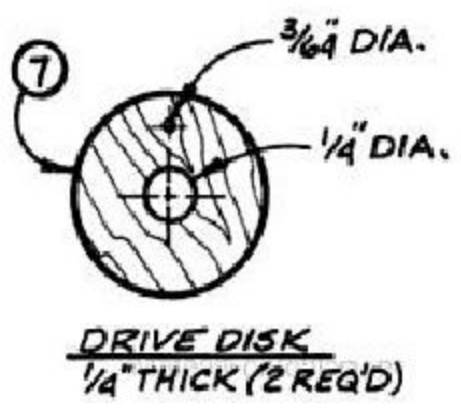
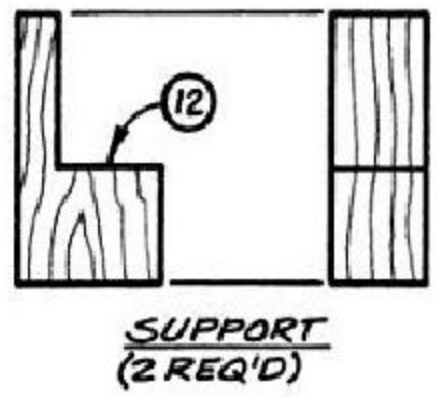
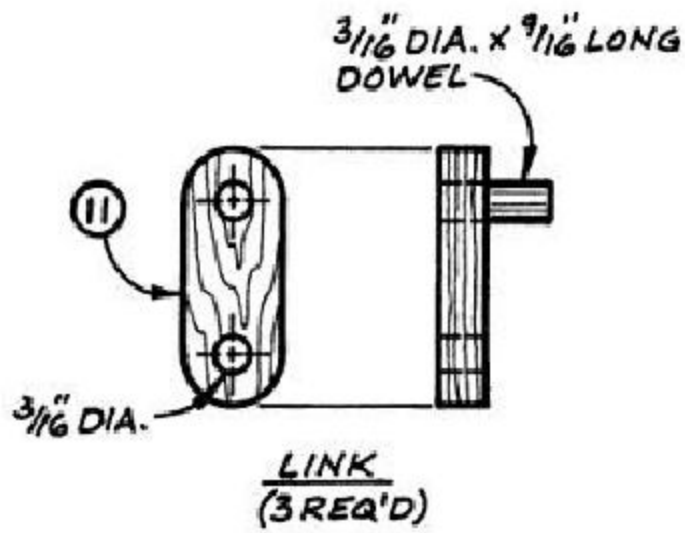
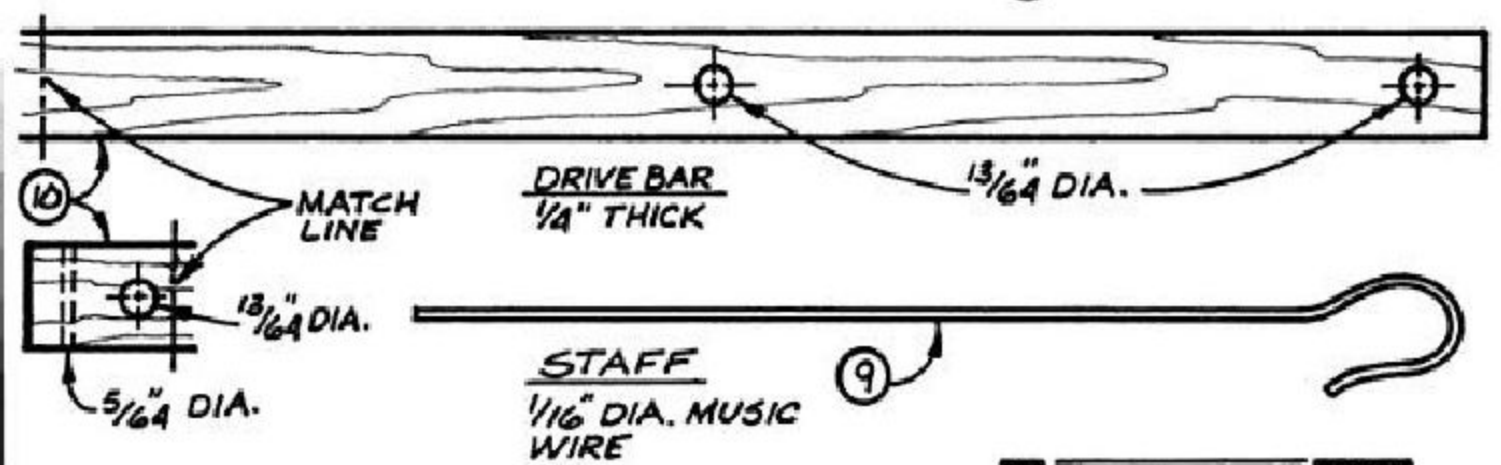
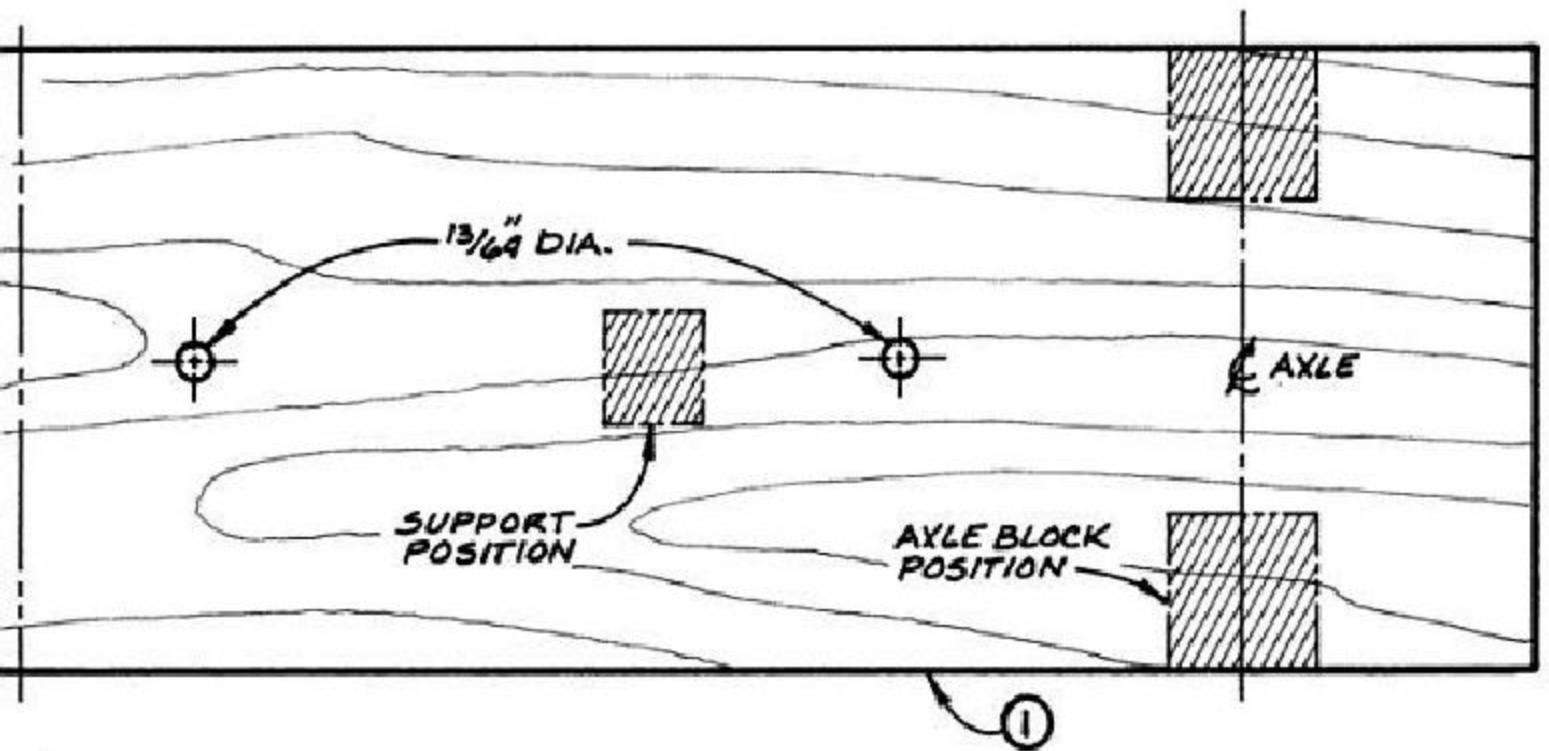

HINGED SNAKE

NOTE: PAINT PARTS BEFORE ASSEMBLY

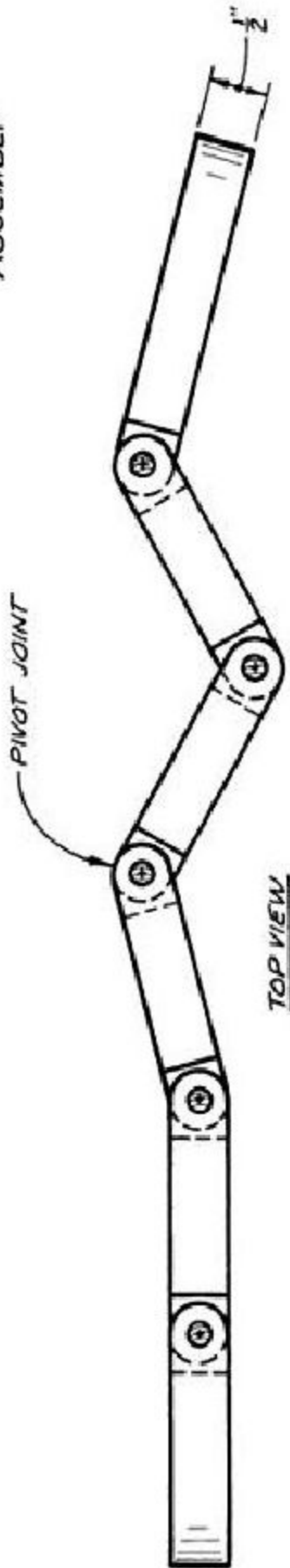

TOP VIEW

APPLY GLUE TO TOP $\frac{1}{4}$ " OF DOWEL TO KEEP THE JOINT FREE-MOVING

$\frac{3}{16}$ " DOWEL STOCK

DRILL TONGUE PORTION OF THE JOINT $\frac{1}{16}$ " OVERSIZE

DARK GREEN

LIGHT GREEN

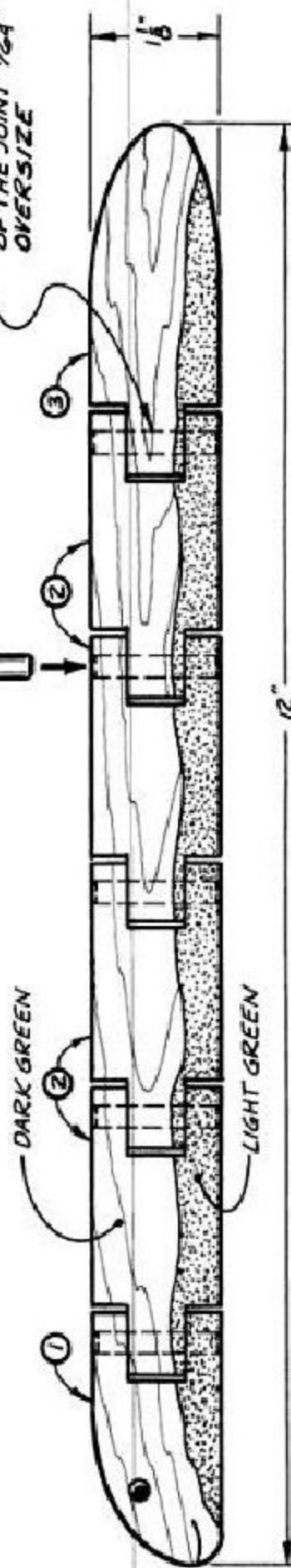

FULL-SIZE PATTERNS

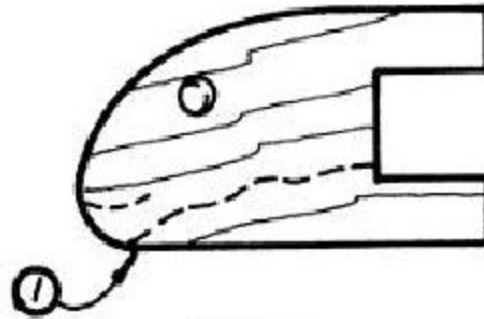

HEAD
1/2" THICK

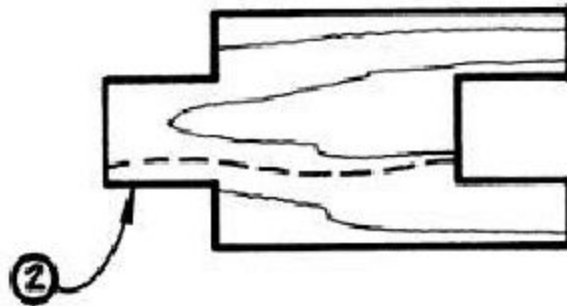

BODY
1/2" THICK (4 REQ'D)

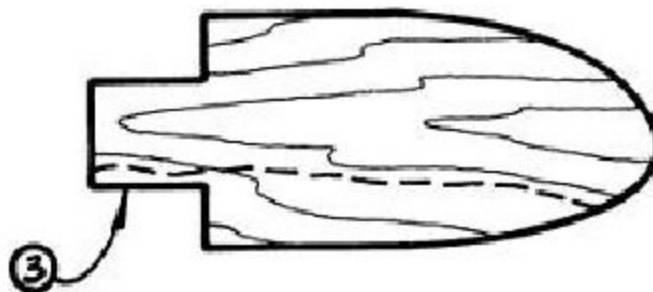

TAIL
1/2" THICK

FLYING CHICKEN

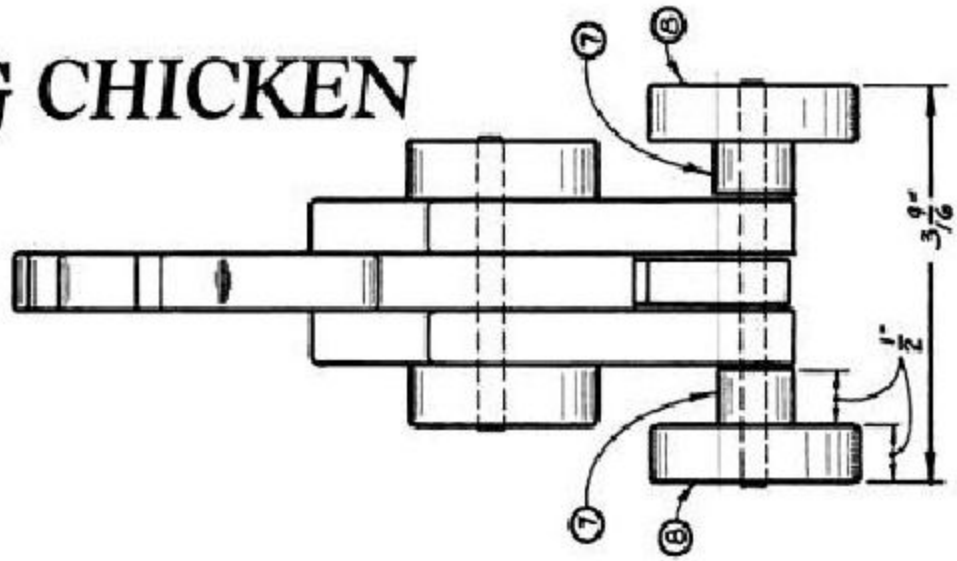
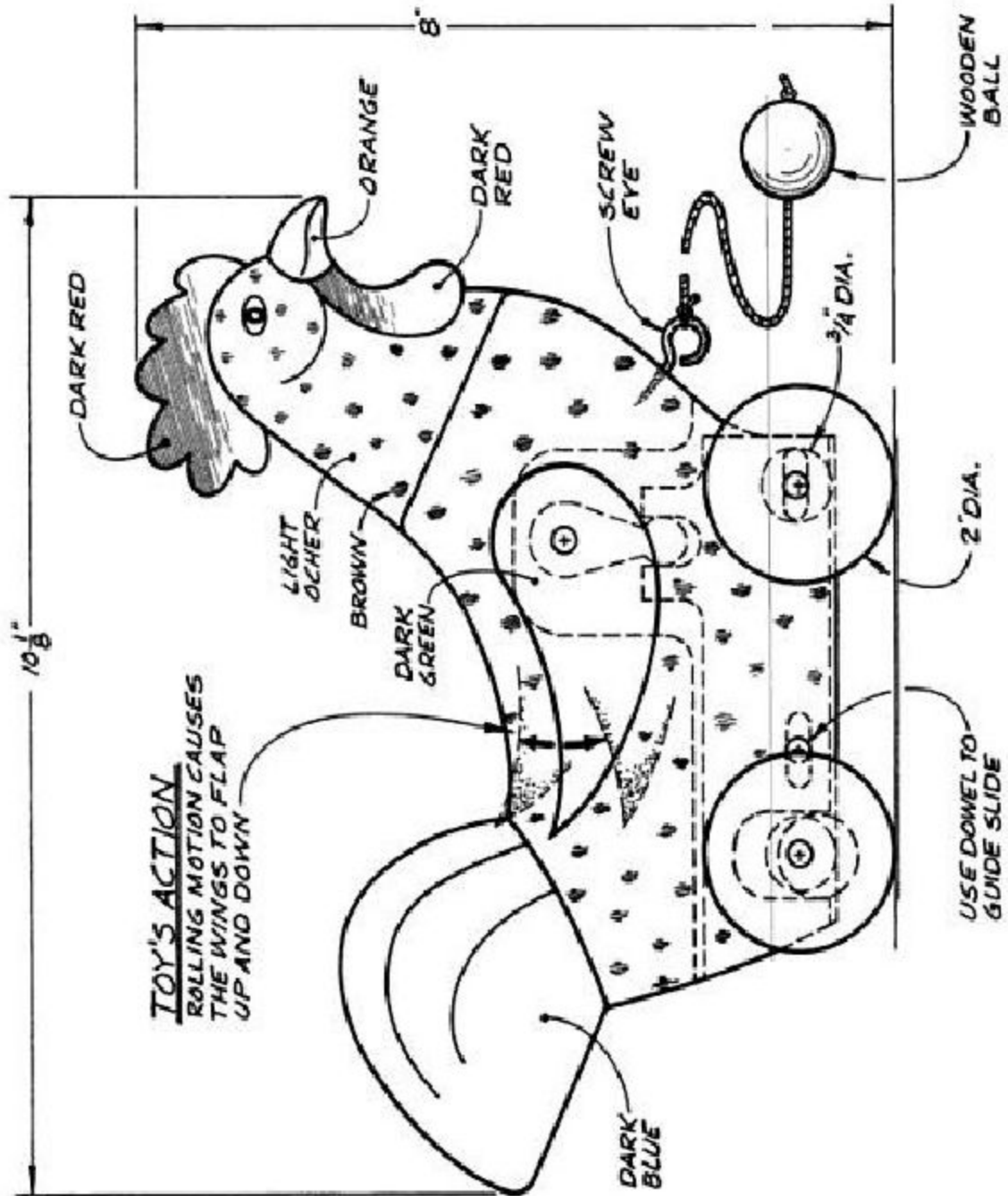

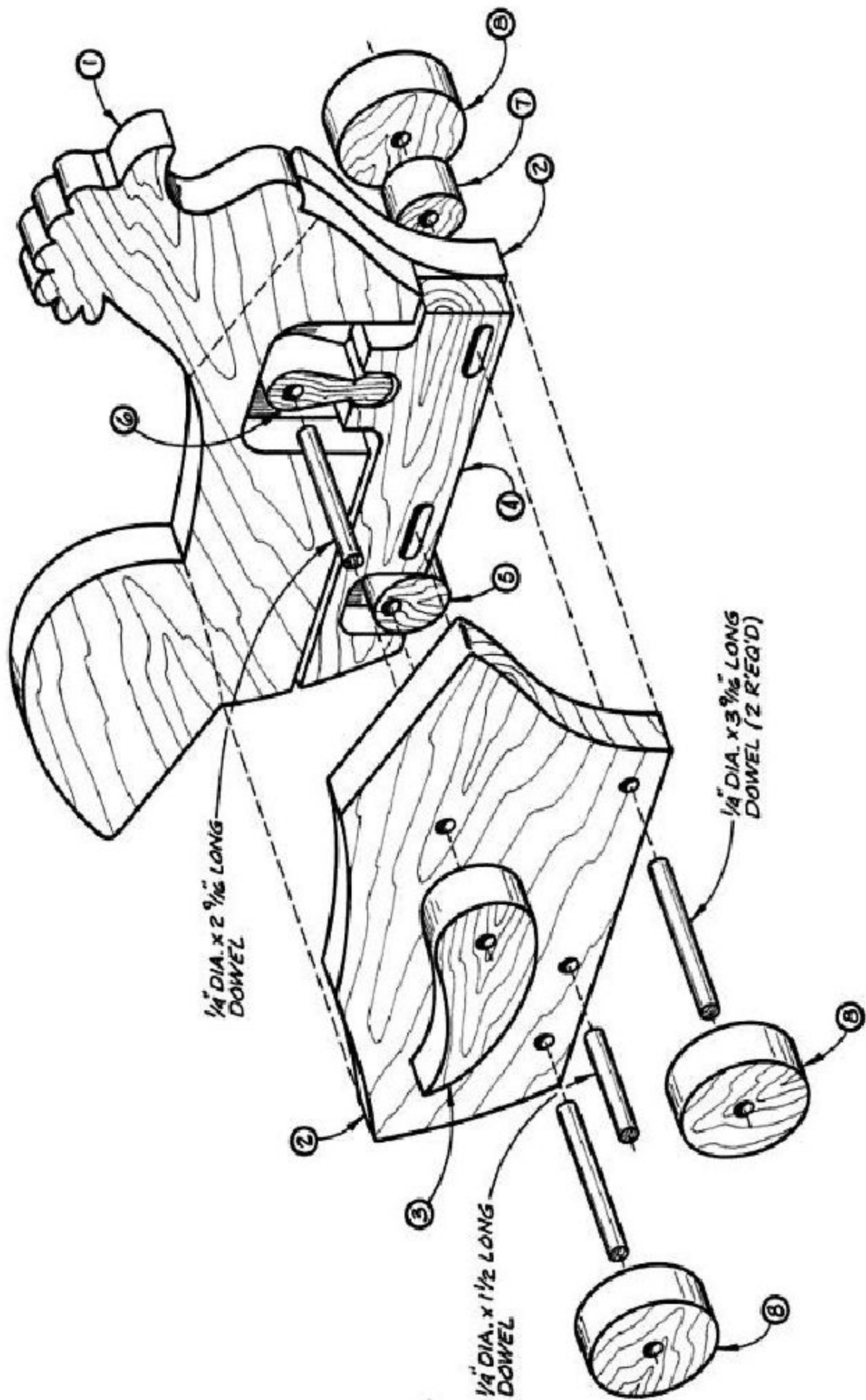

FLYING CHICKEN FULL-SIZE PATTERNS

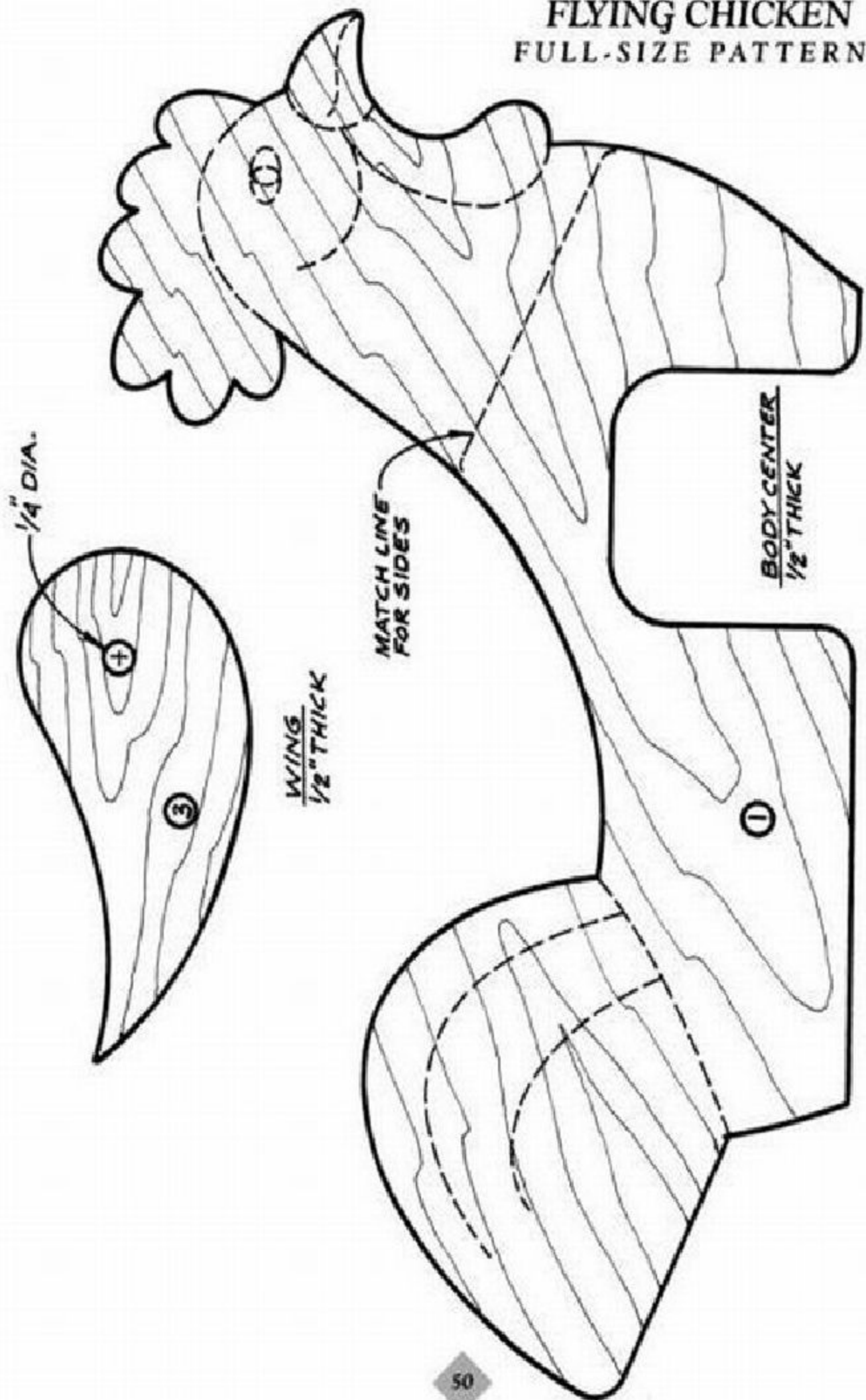

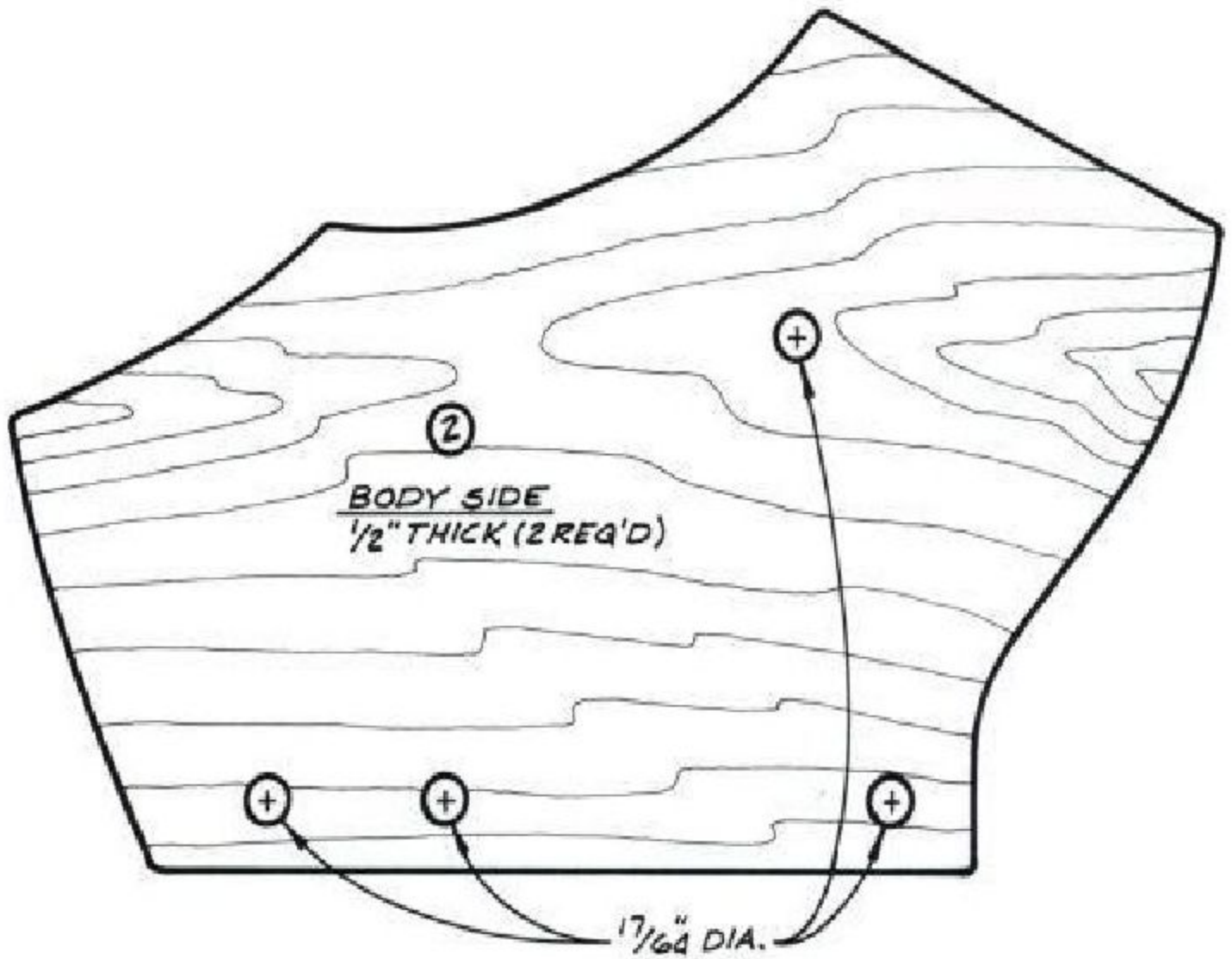

DRIVE DISK
7/16" THICK

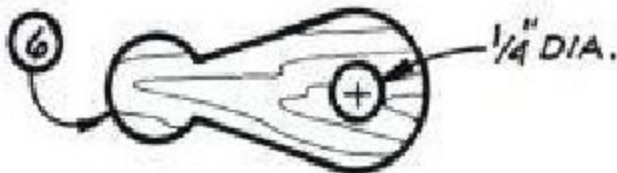

DRIVE LEVER
7/16" THICK

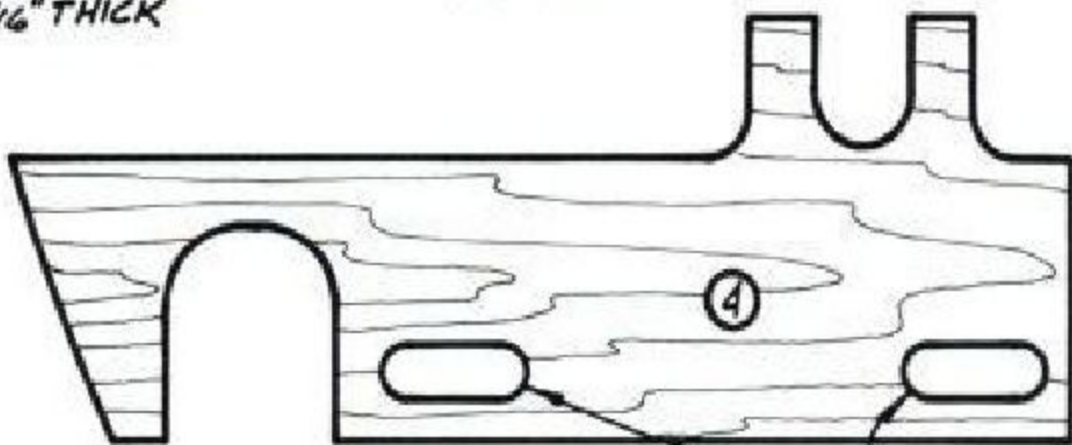

SLIDE
7/16" THICK

CLIMBING MONKEY



TOY'S ACTION
DROP MONKEY ON FIRST
RUNG AND WATCH HIM
DESCEND THE LADDER

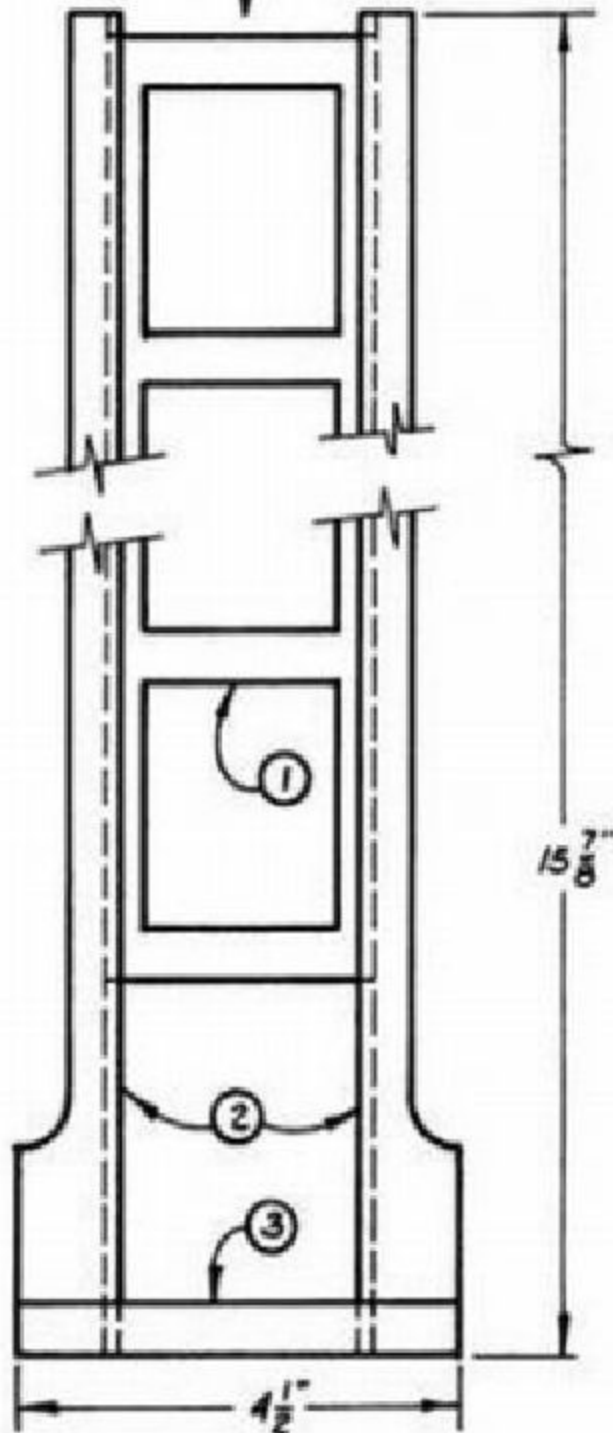

FRONT VIEW

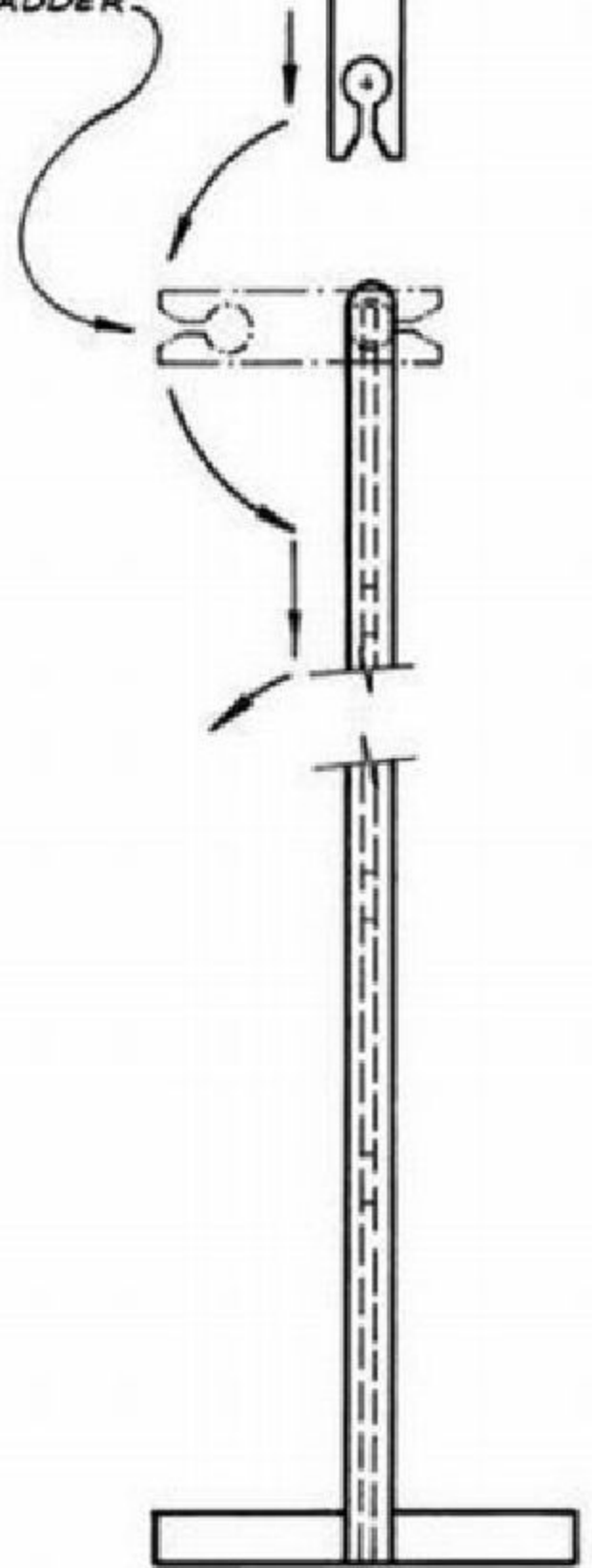

SIDE VIEW

FULL-SIZE PATTERNS

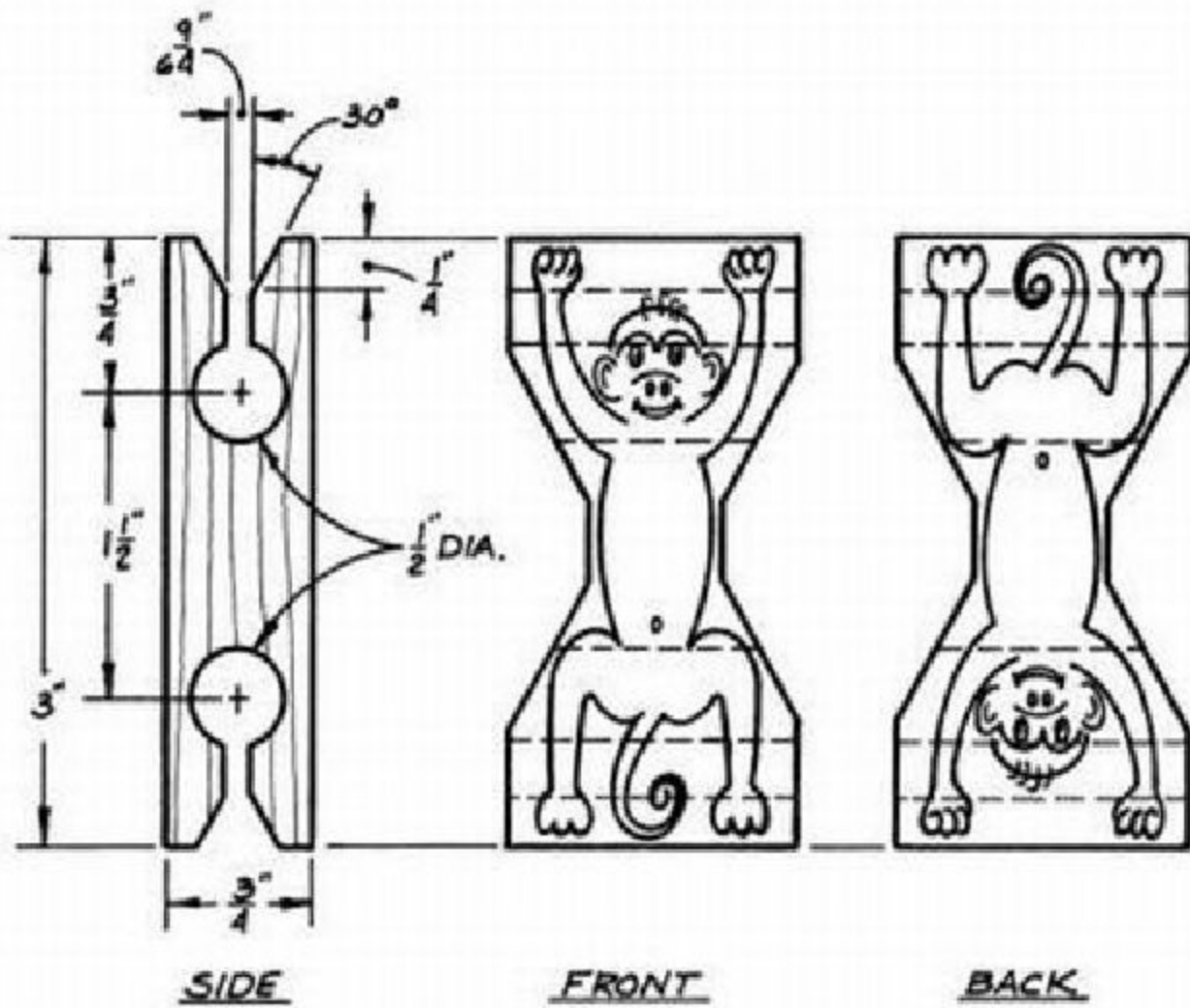

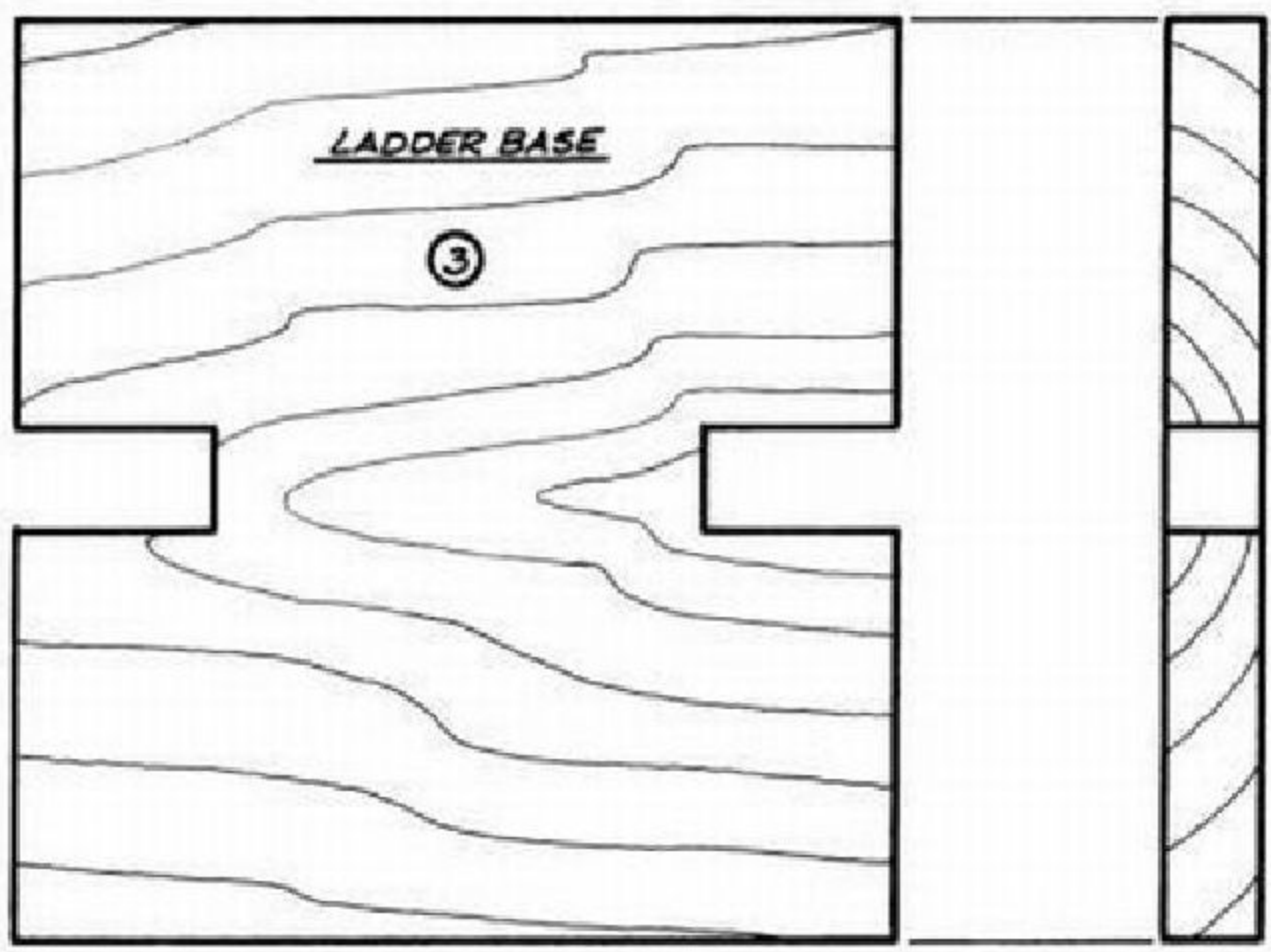
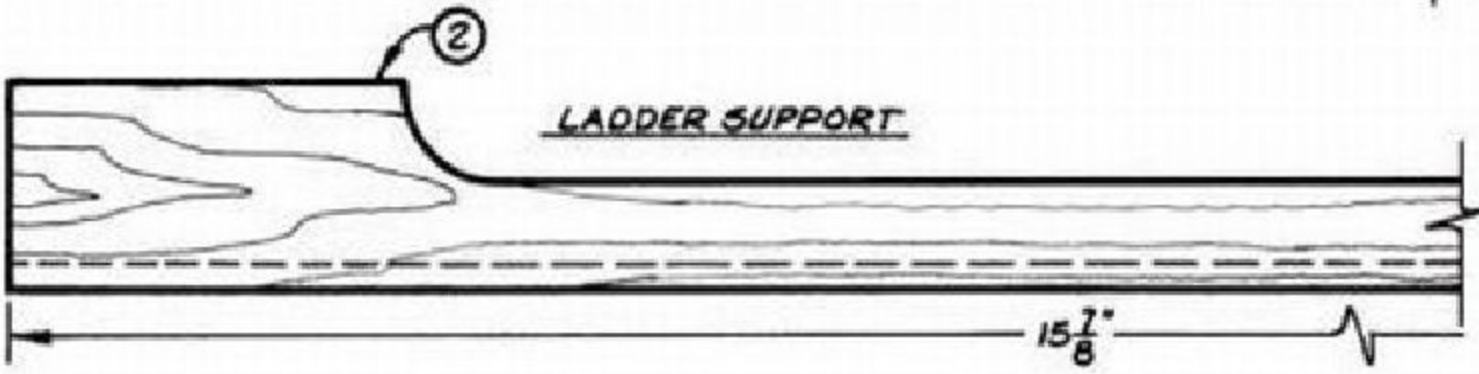
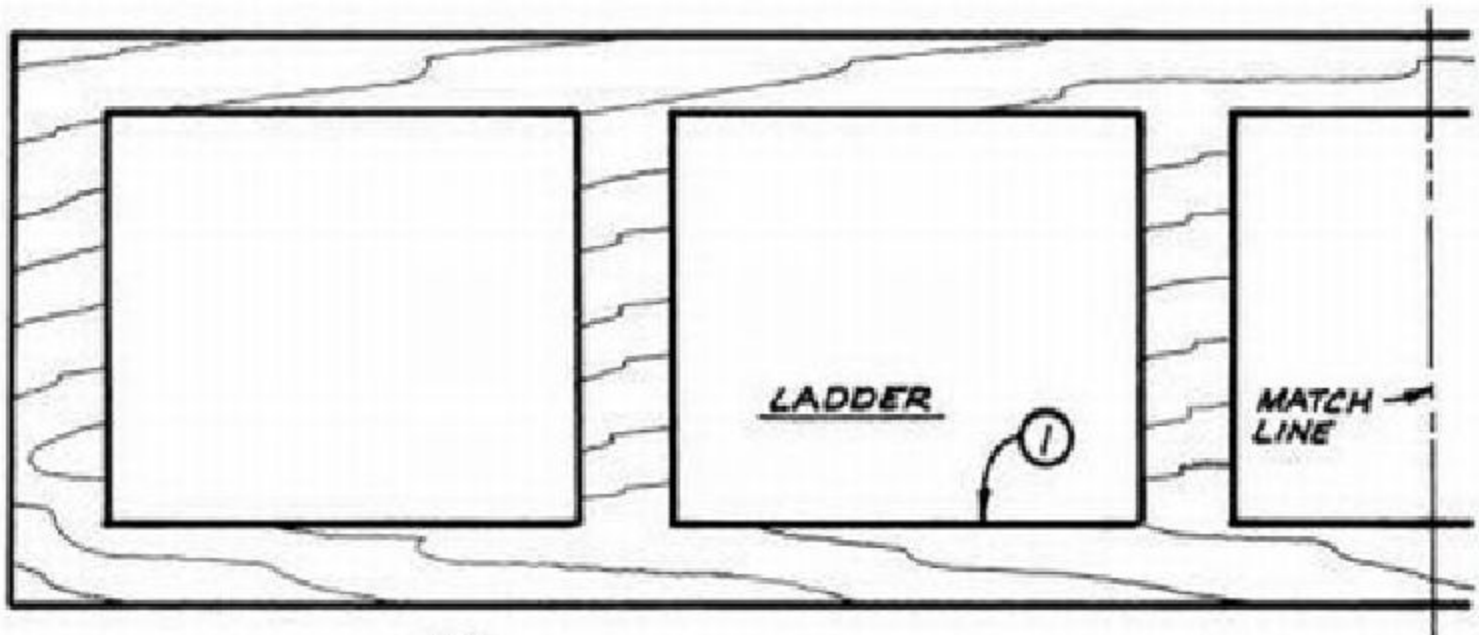

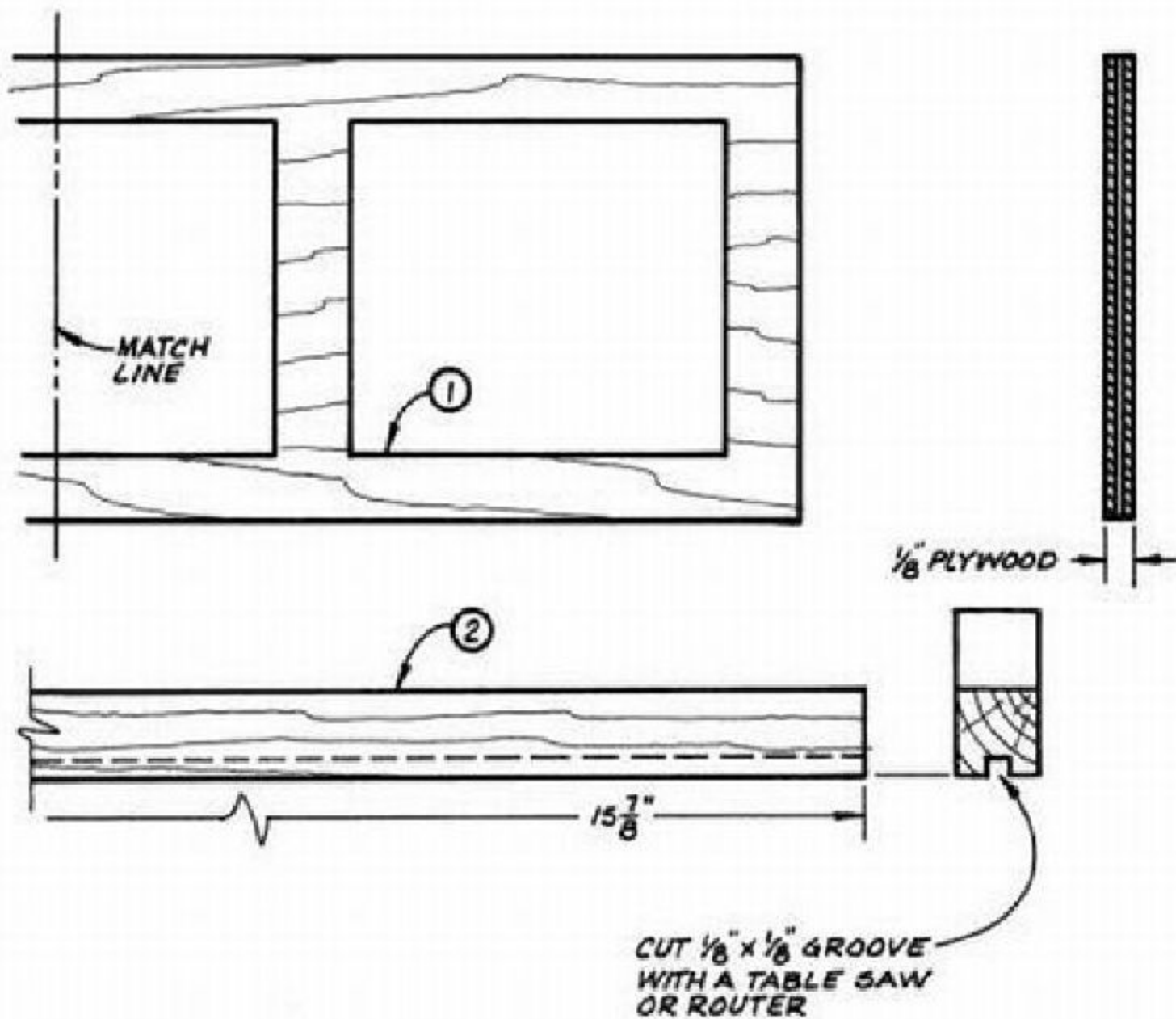

CLIMBING MONKEY FULL-SIZE PATTERNS

PEDALING CYCLIST

TOY'S ACTION
 ROLLING MOTION CAUSES
 THE CYCLIST'S LEGS TO MOVE
 WITH A PEDALING ACTION

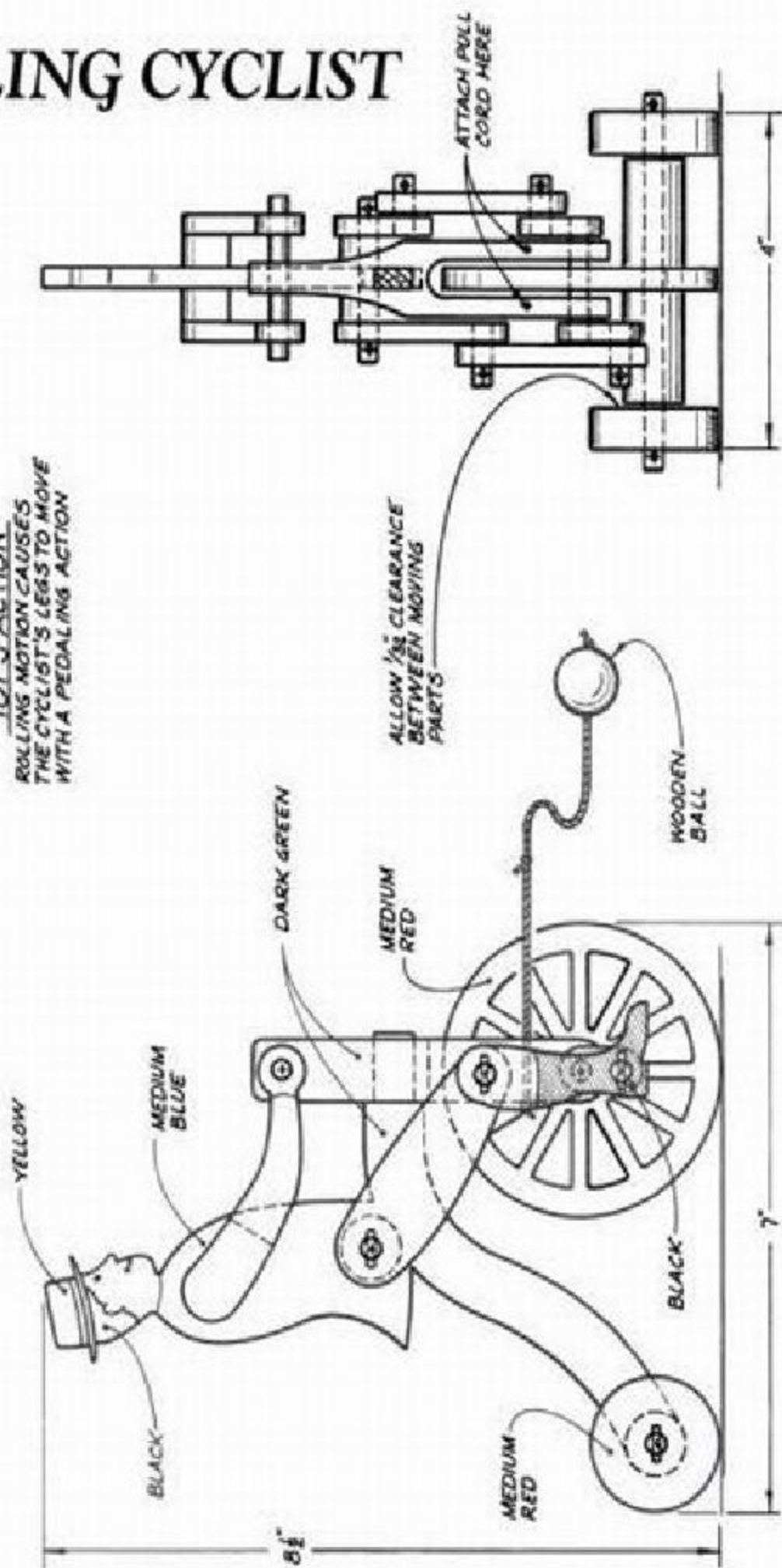

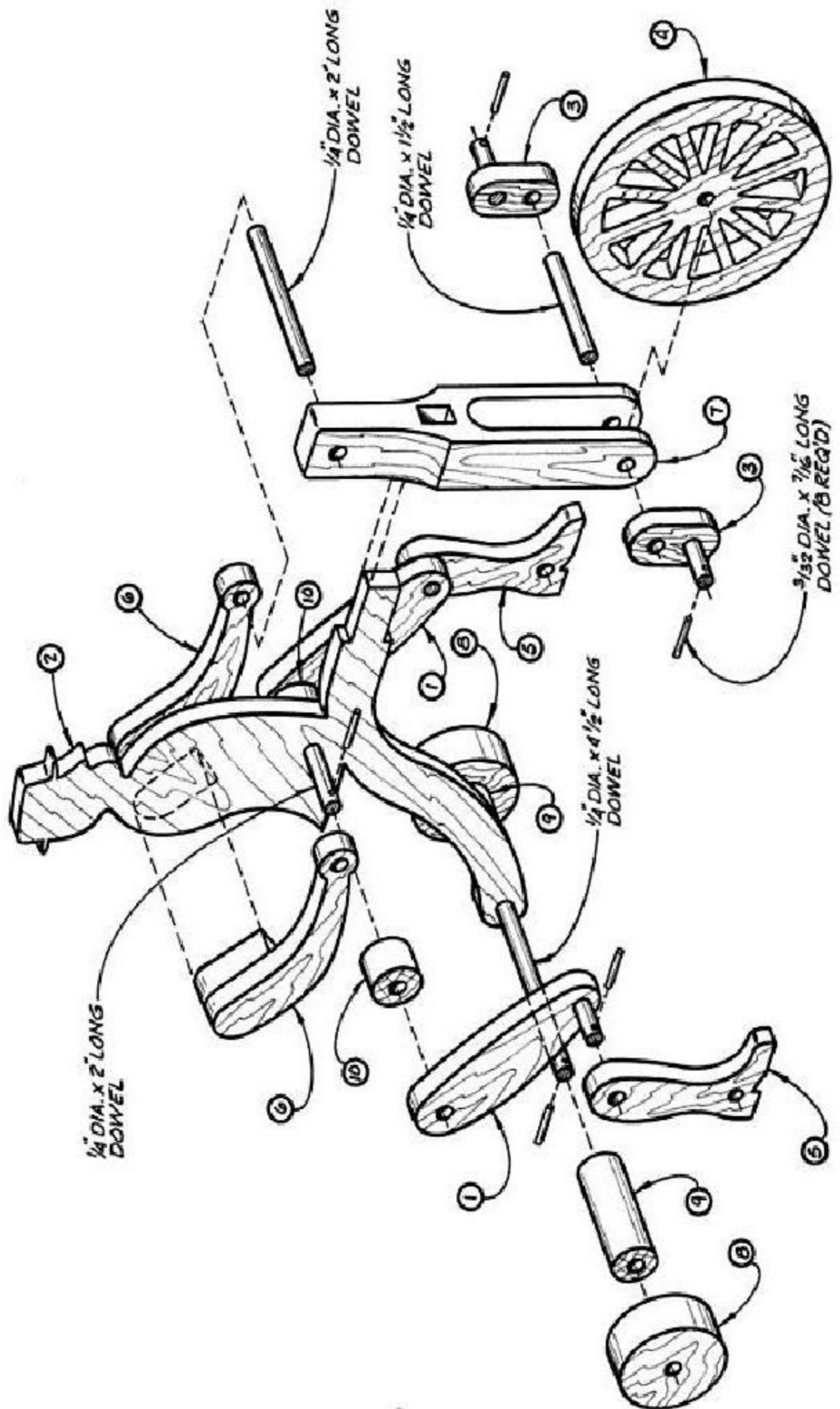

PEDALING CYCLIST

FULL-SIZE PATTERNS

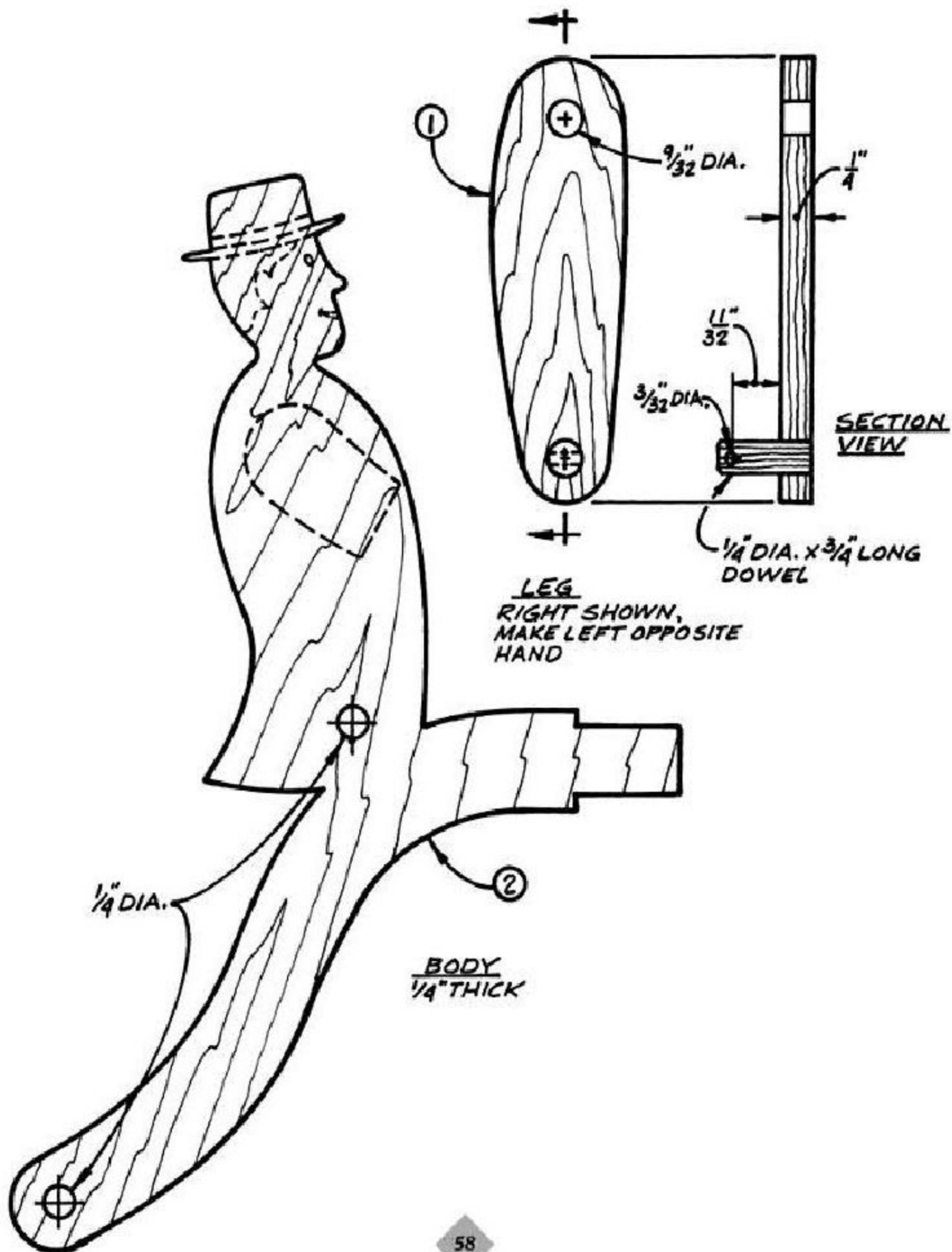

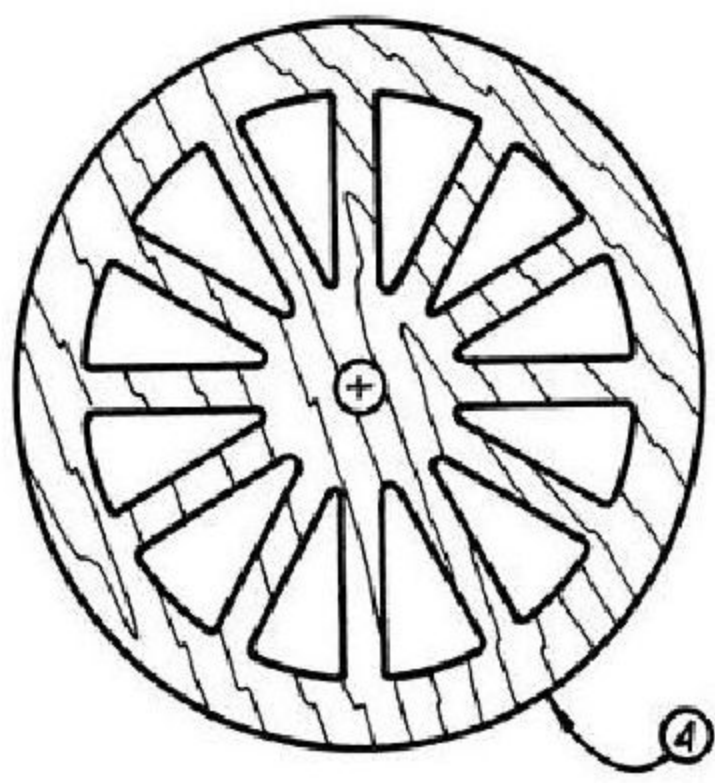
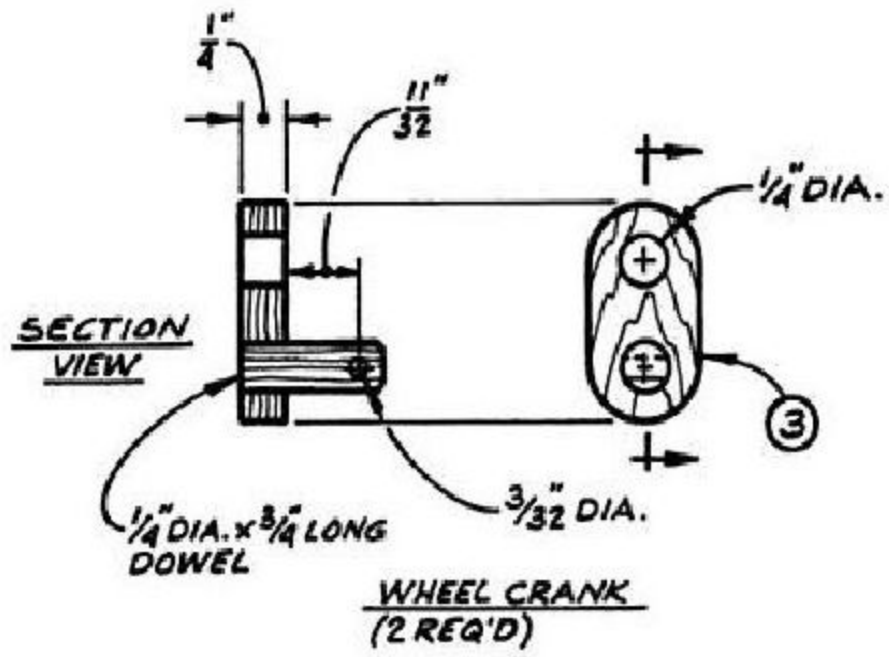

FRONT WHEEL
 $\frac{1}{4}$ " THICK

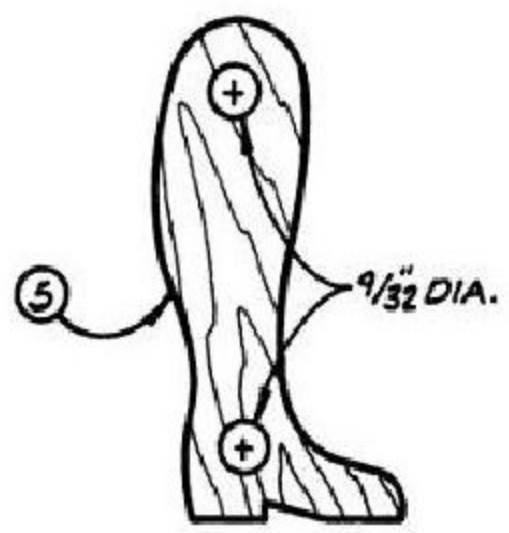

LOWER LEG
 $\frac{1}{4}$ " THICK (2 REQ'D)

PEDALING CYCLIST

FULL-SIZE PATTERNS

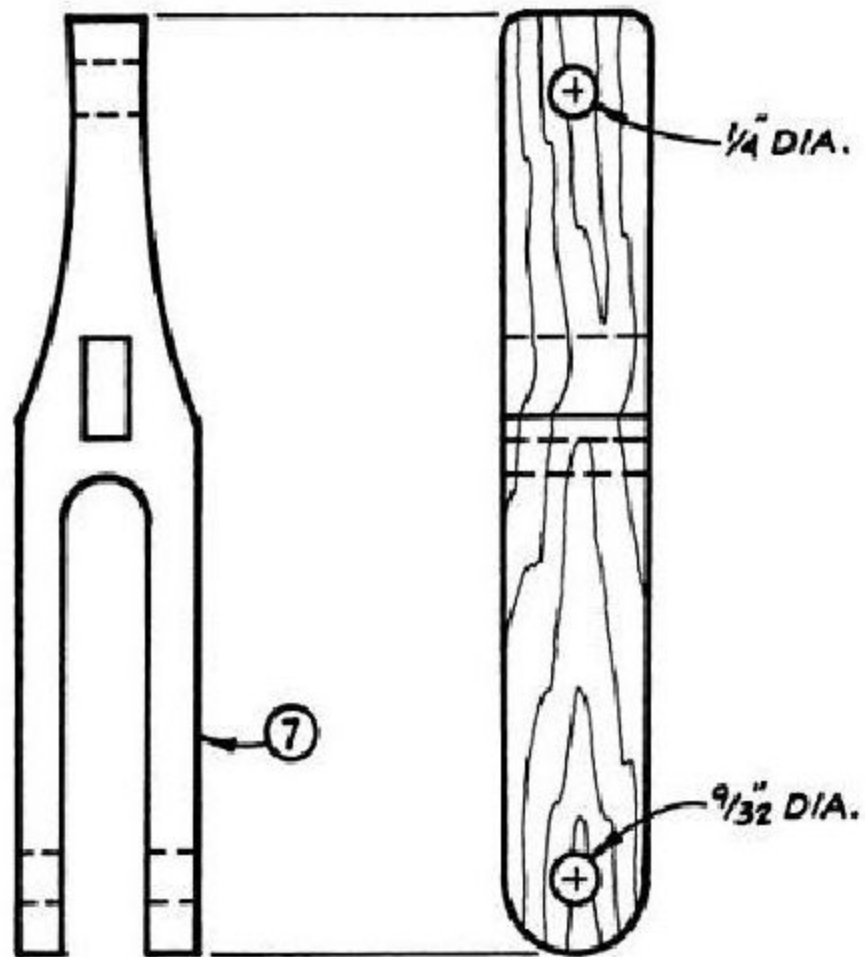

FRONT WHEEL FORK

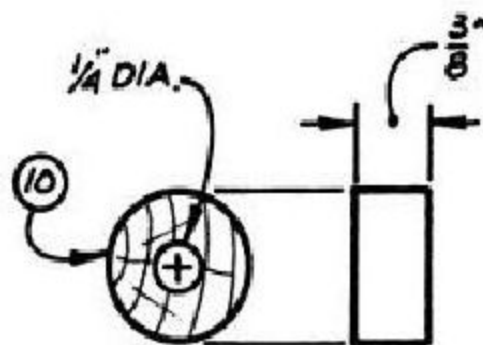

ARM SPACER
(2 REQ'D)

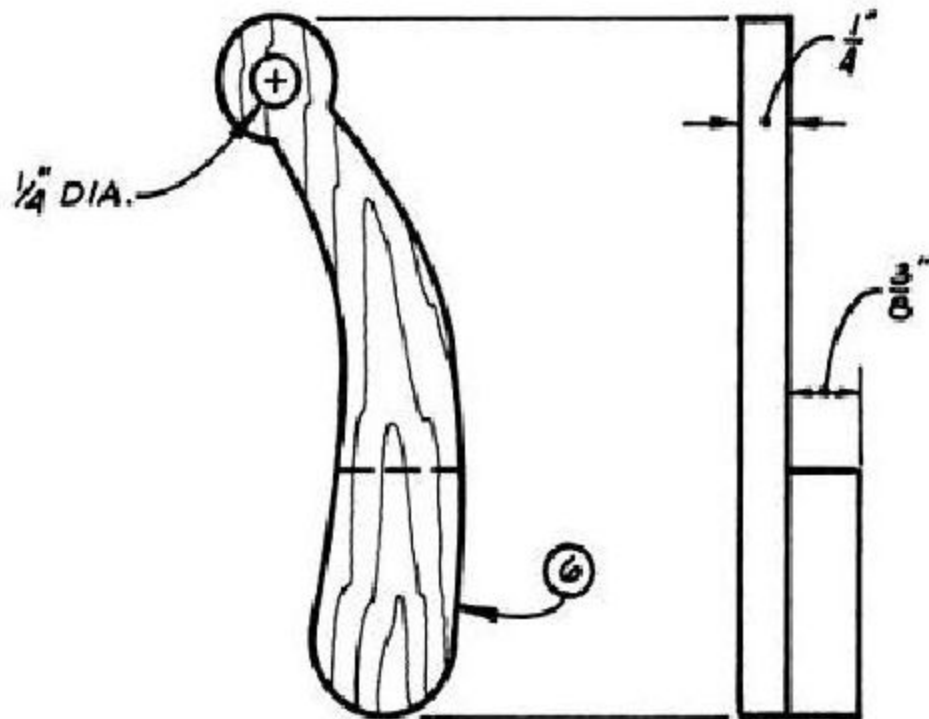

ARM
 RIGHT SHOWN,
 MAKE LEFT OPPOSITE
 HAND

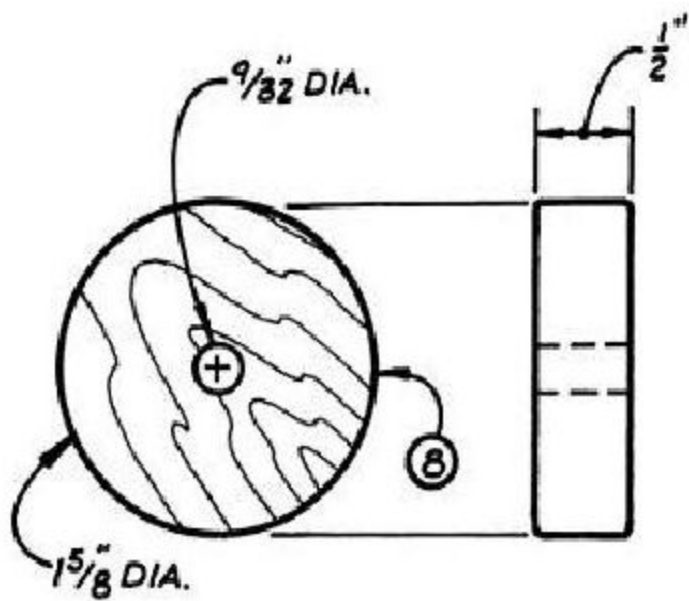

REAR WHEEL
 (2 REQ'D)

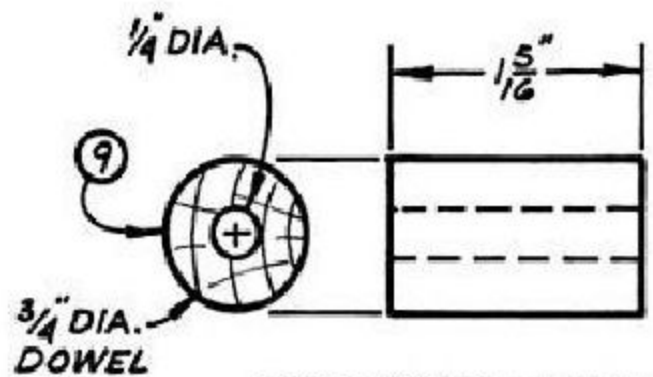

REAR WHEEL SPACER
 (2 REQ'D)

WALKING CROCODILE

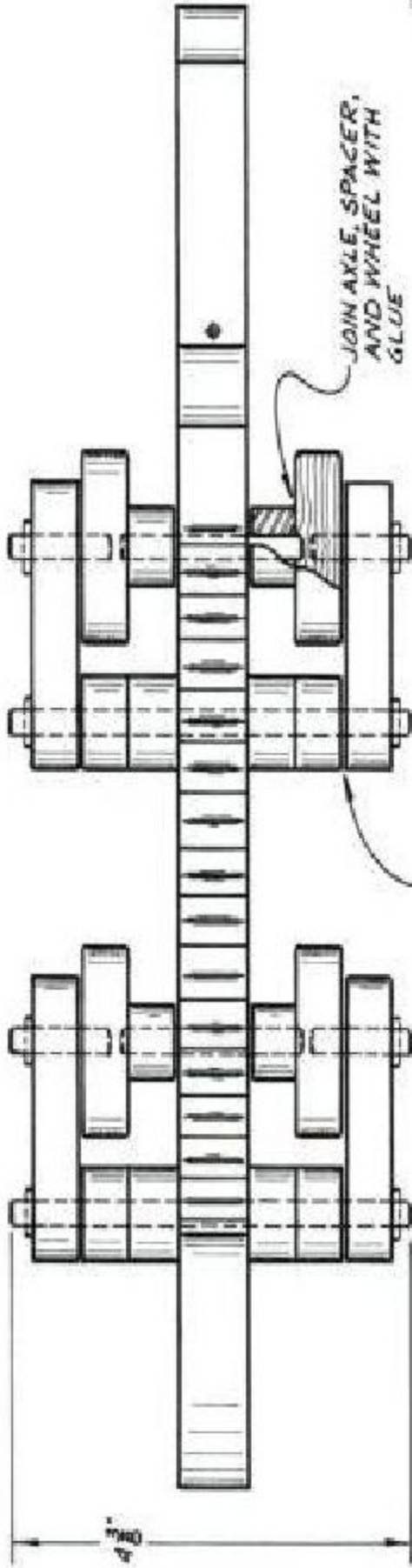

TOY'S ACTION
 ROLLING MOTION CAUSES THE LEGS TO MOVE WITH A WALKING ACTION.

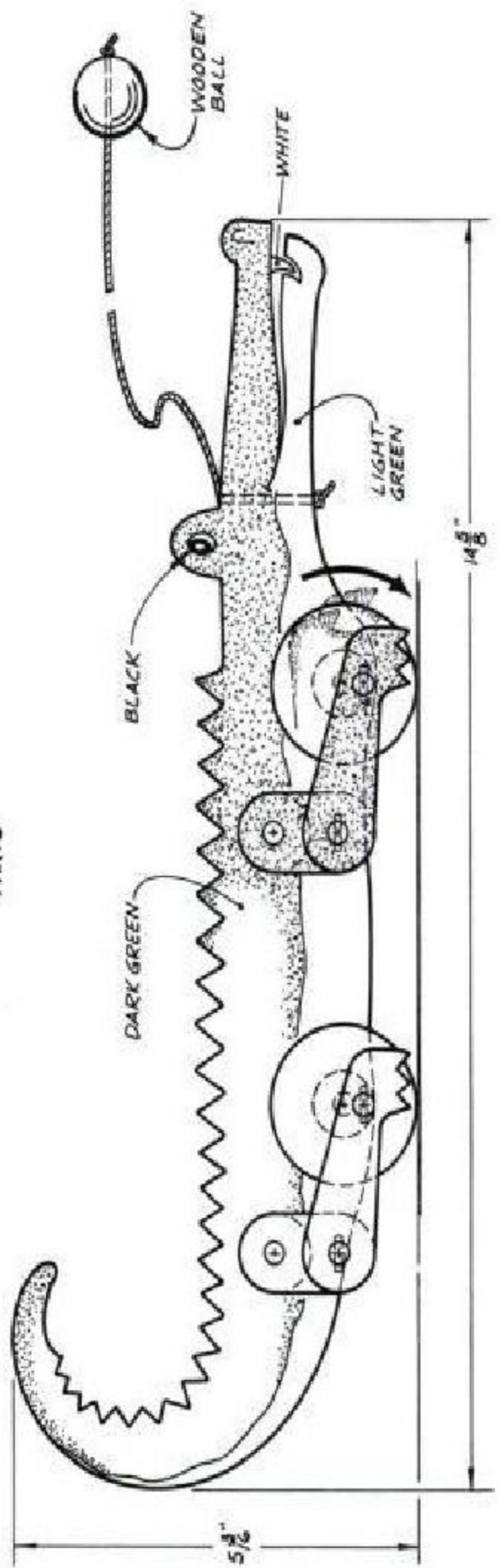

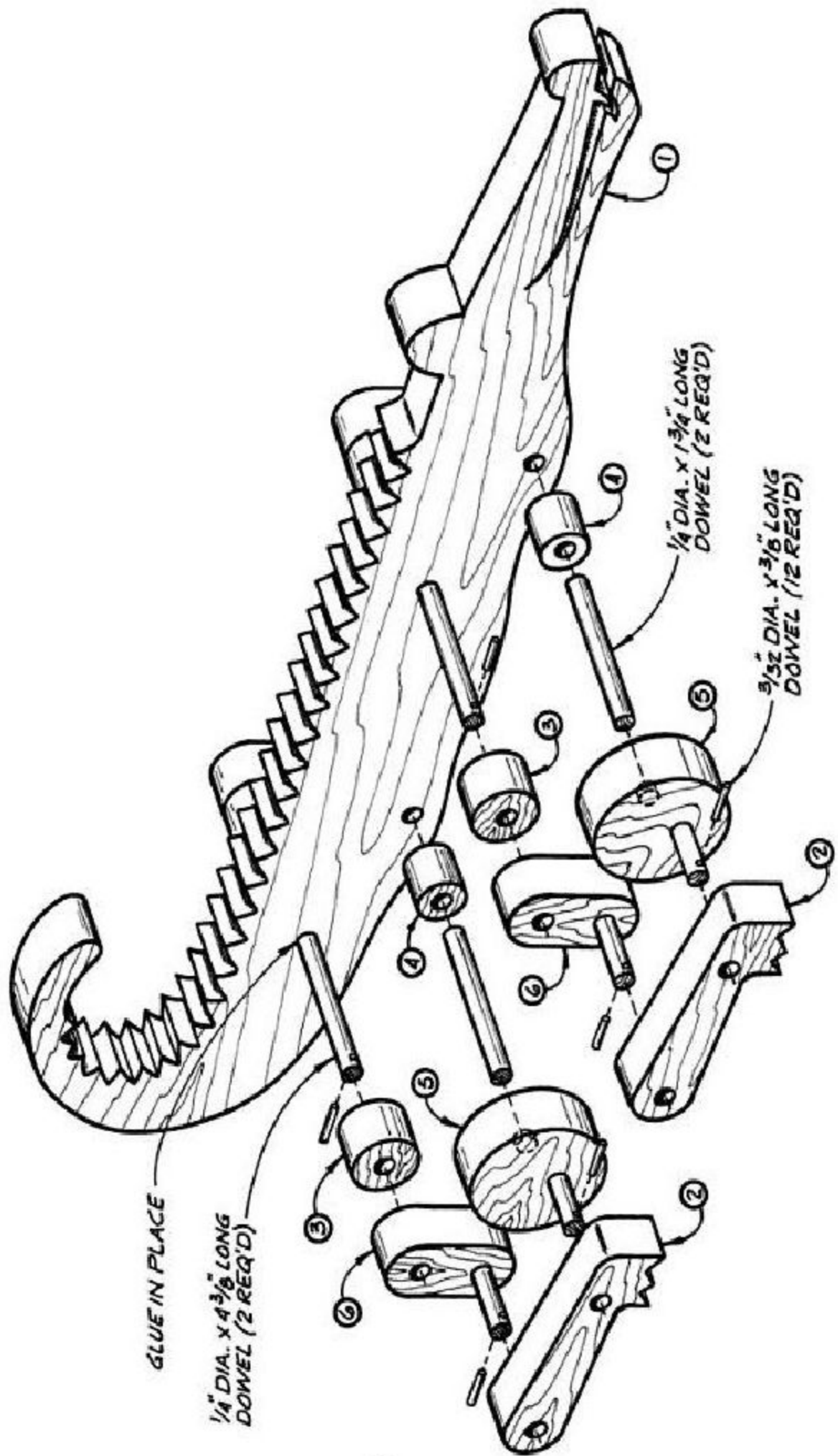

WALKING CROCODILE

FULL-SIZE PATTERNS

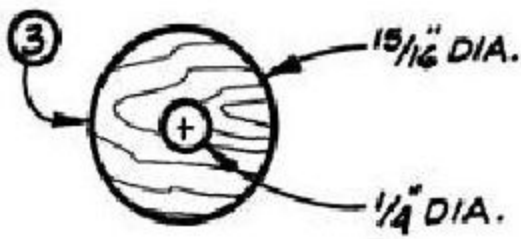

ARM SPACER
1/2" THICK (4 REQ'D)

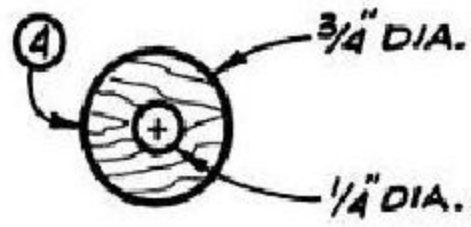

WHEEL SPACER
1/2" THICK (4 REQ'D)

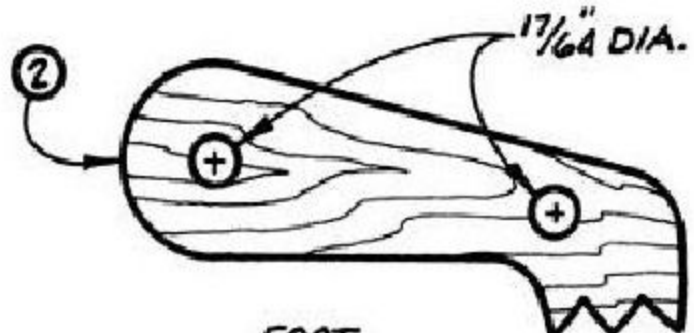

FOOT
1/2" THICK (4 REQ'D)

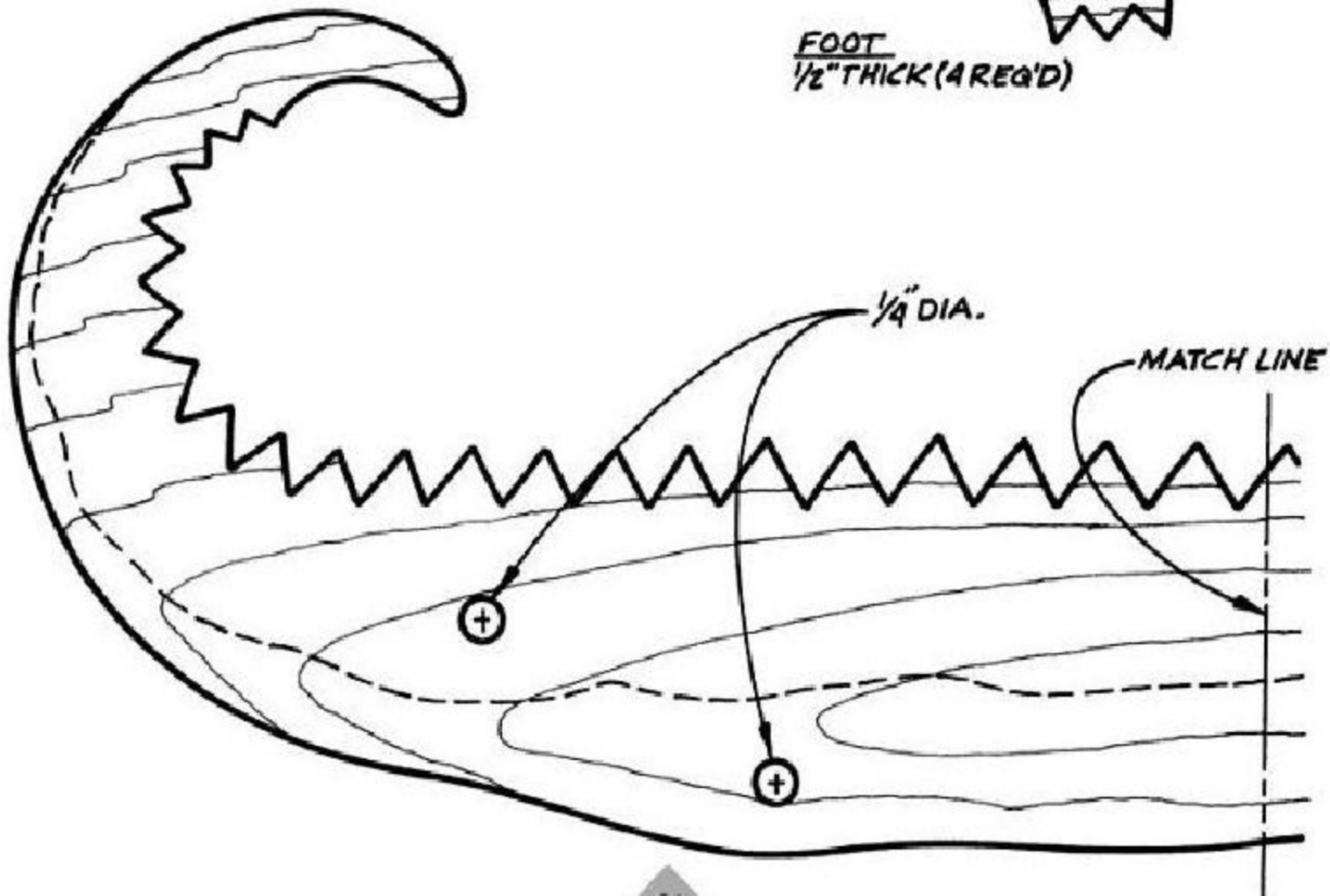

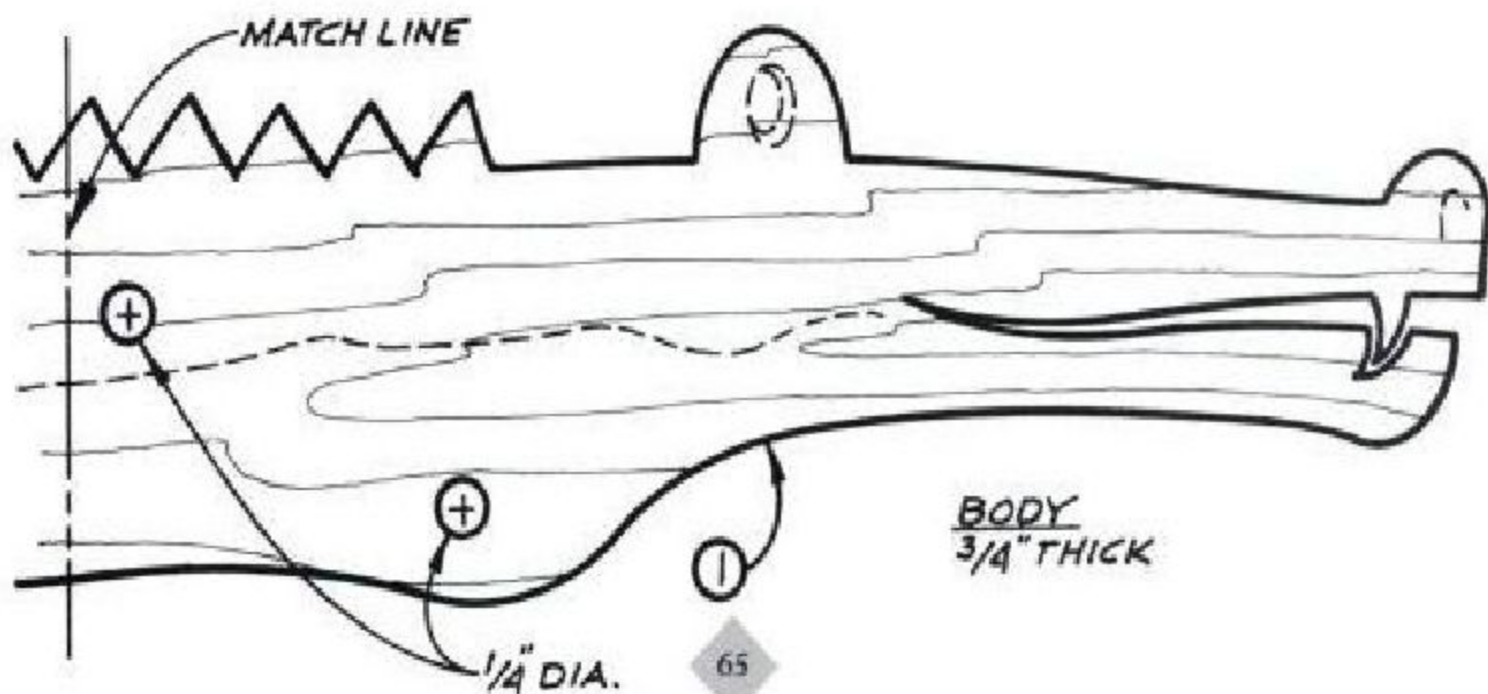
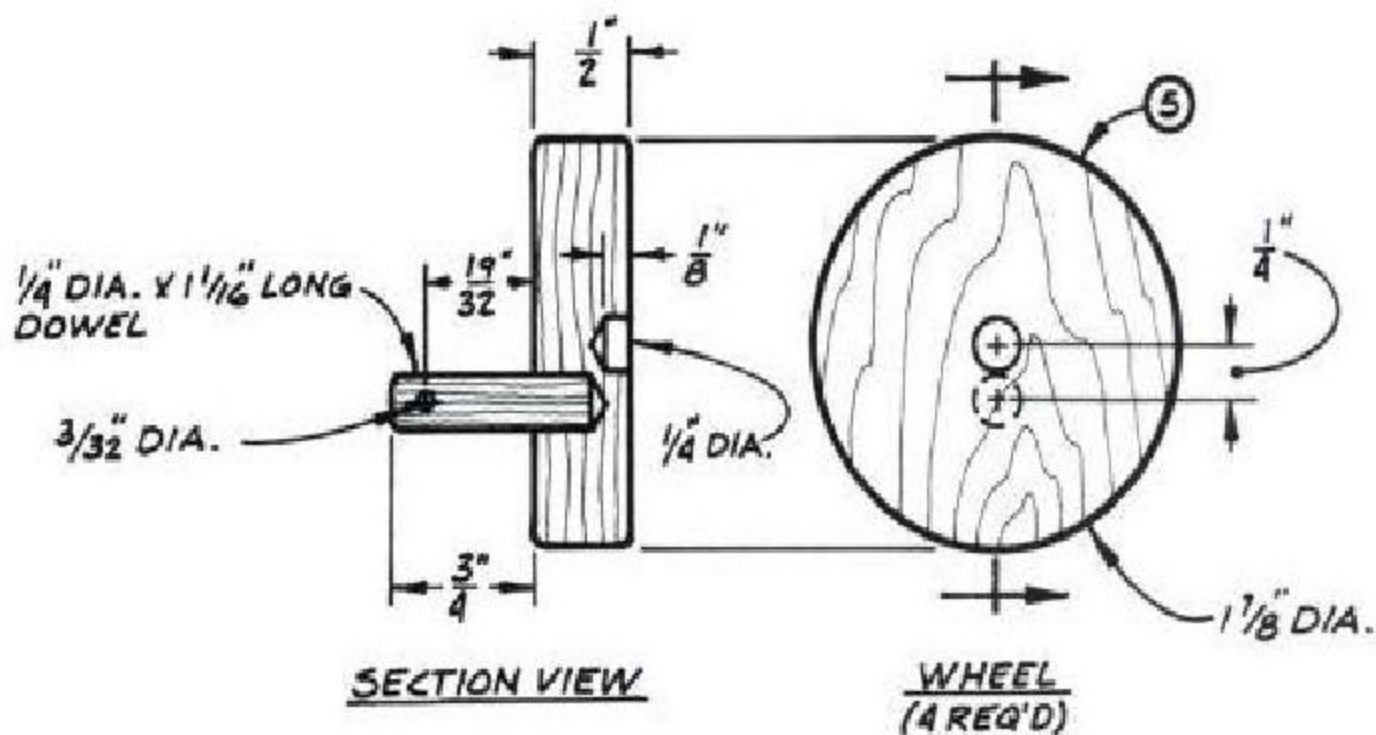
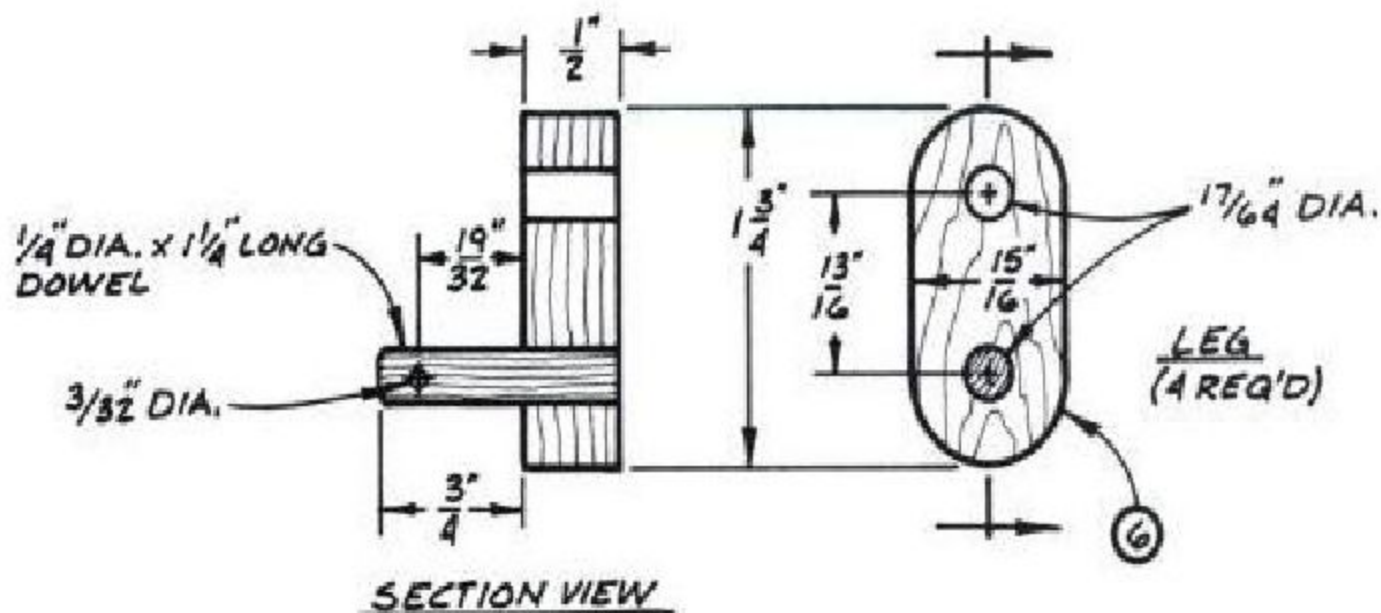

HAND-POWERED RAILCAR

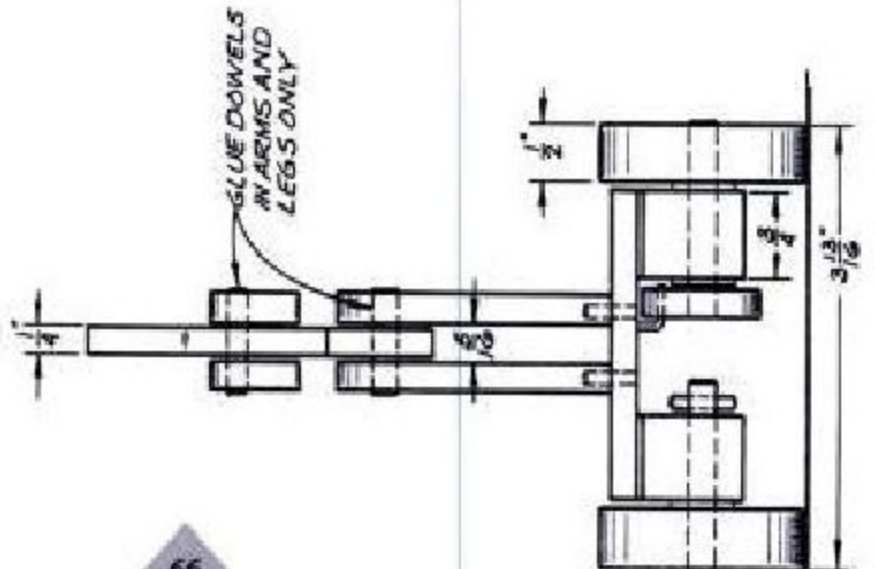
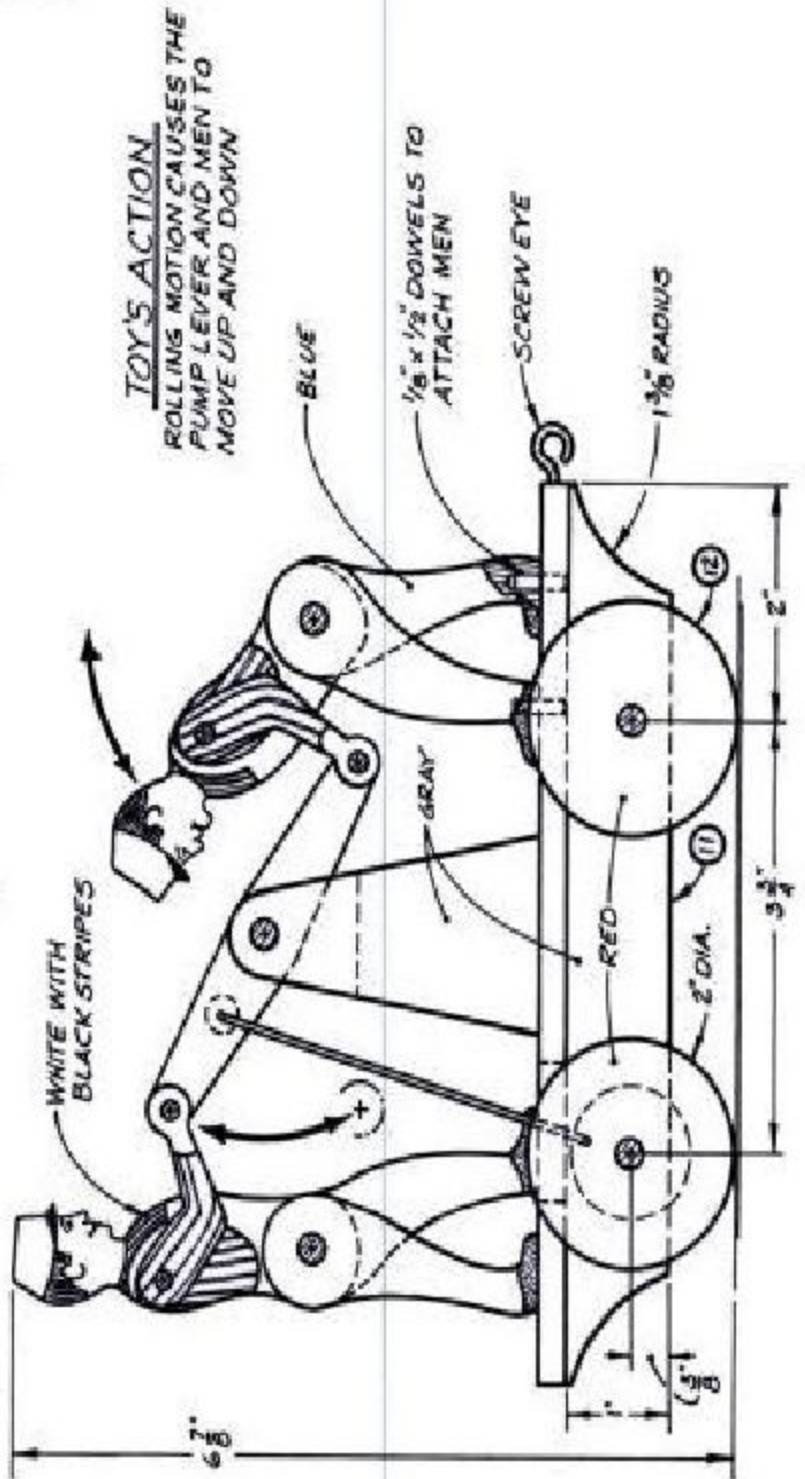
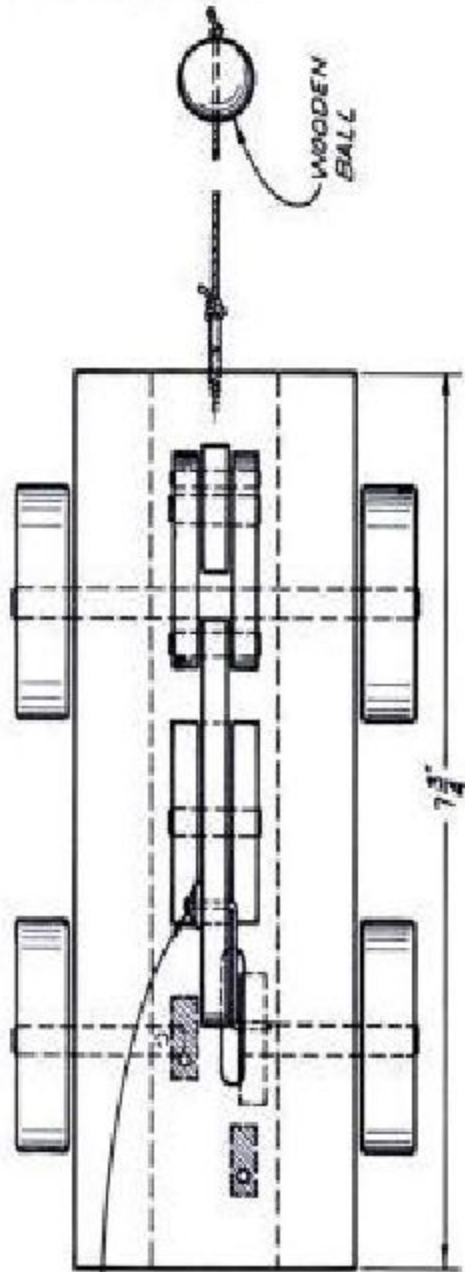

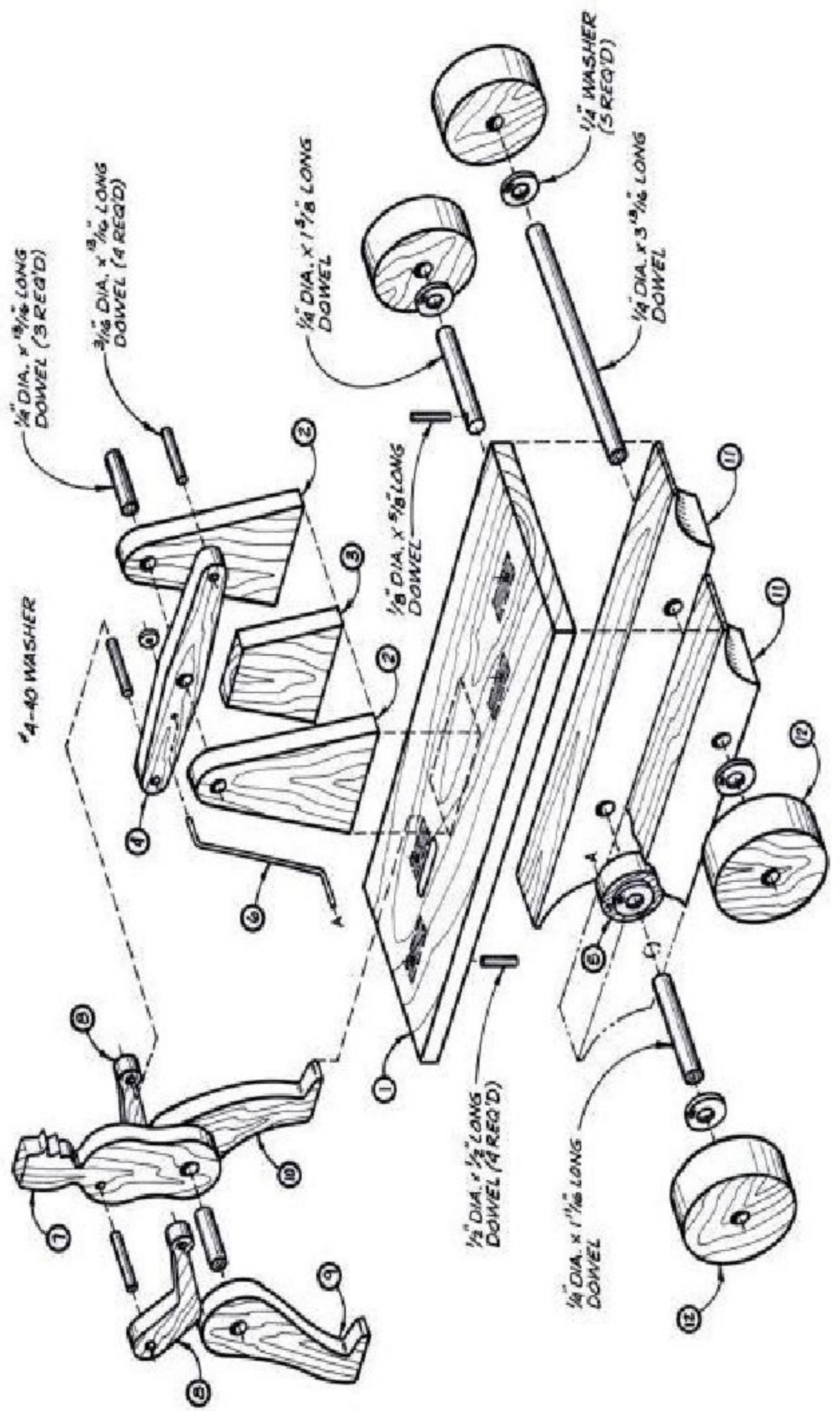

HAND-POWERED RAILCAR

FULL-SIZE PATTERNS

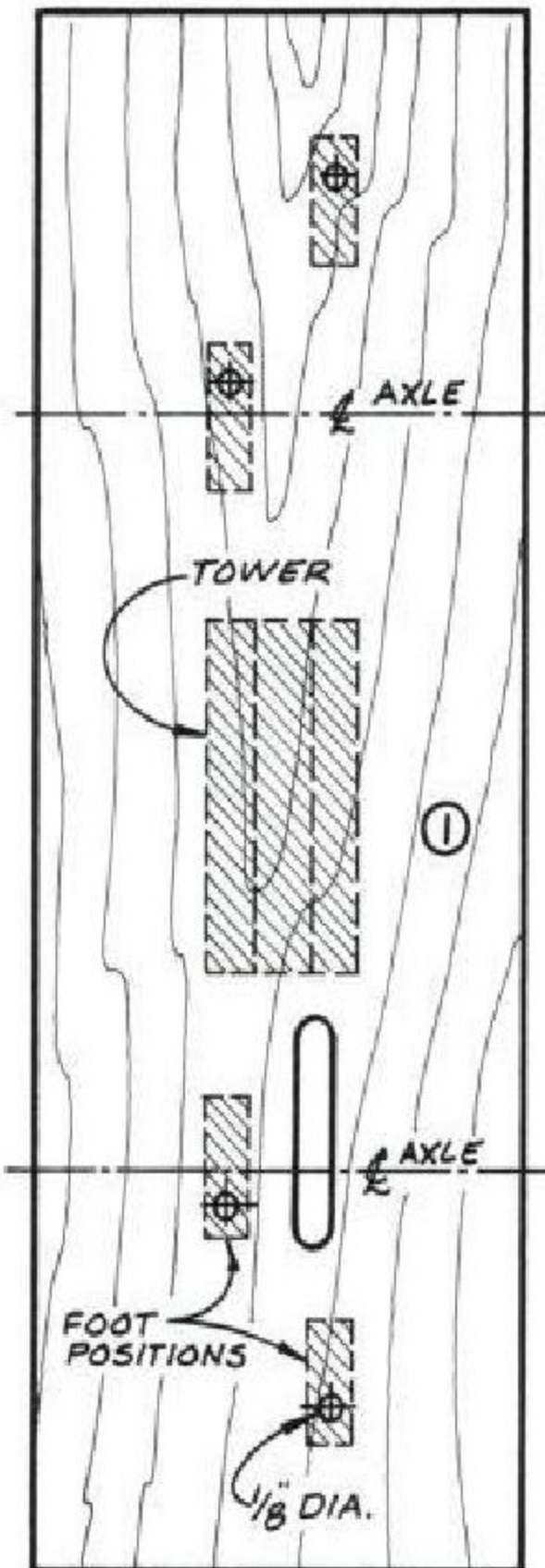

BASE
1/4" THICK

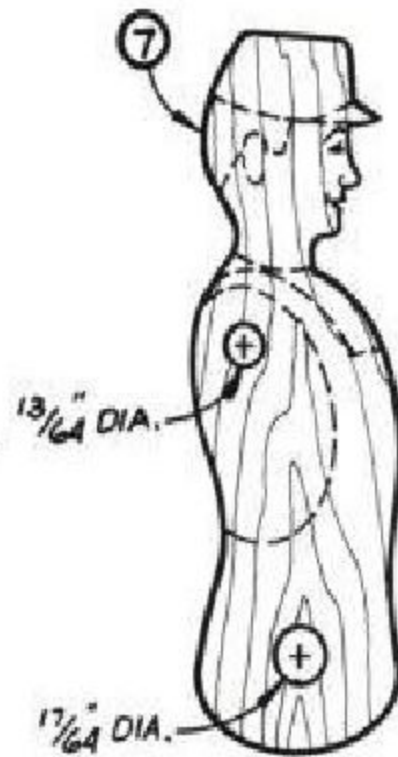

BODY
1/4" THICK (2 REQ'D)

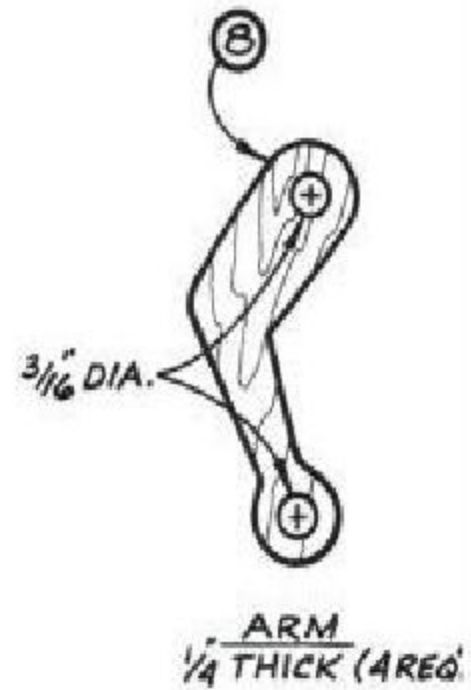

ARM
1/4" THICK (4 REQ'D)

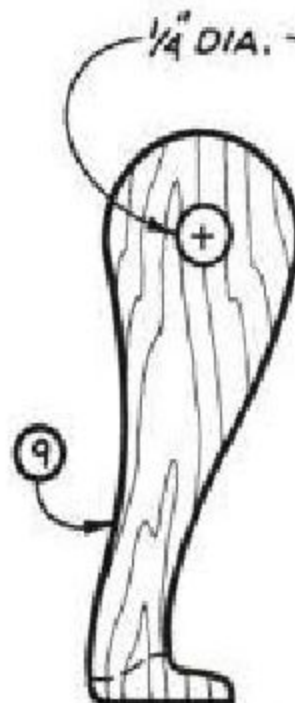

REAR FOOT
1/4" THICK (2 REQ'D)

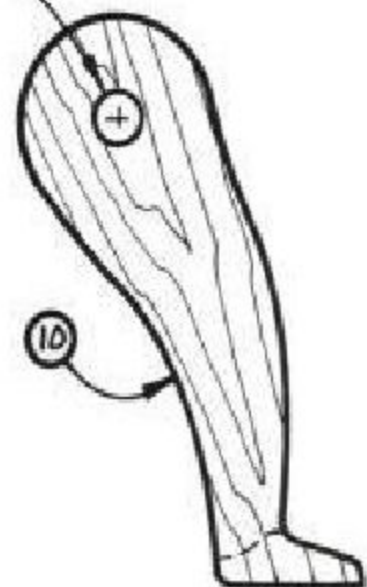

FRONT FOOT
1/4" THICK (2 REQ'D)

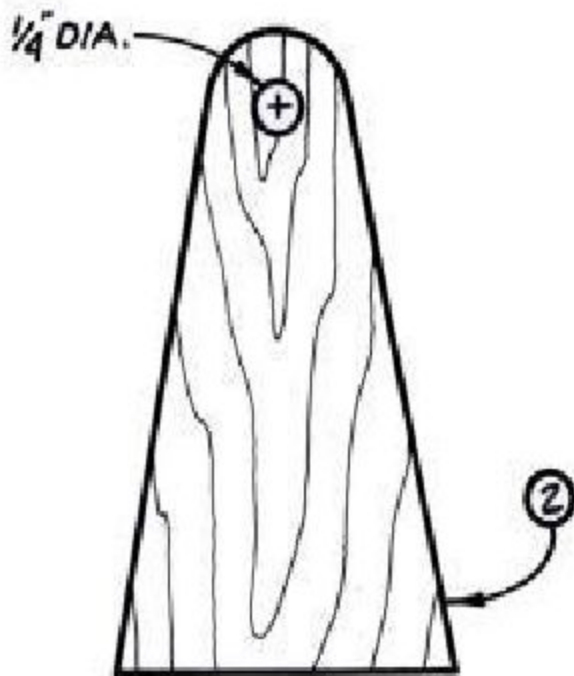

TOWER SIDE
 $\frac{1}{4}$ " THICK (2 REQ'D)

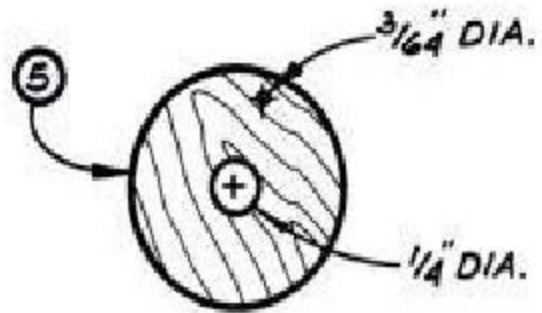

DRIVE DISK
 $\frac{1}{4}$ " THICK

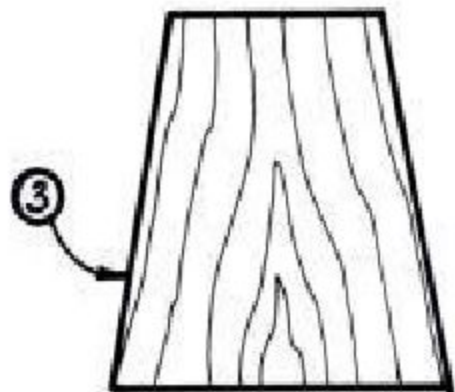

TOWER CENTER
 $\frac{5}{16}$ " THICK

LEVER
 $\frac{1}{4}$ " THICK

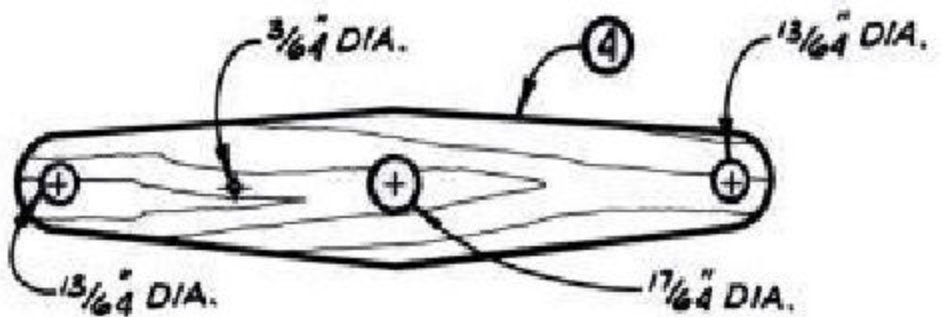

DRIVE ROD
 $\frac{1}{16}$ " MUSIC WIRE

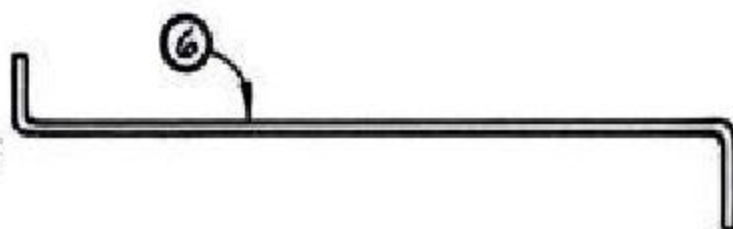

HINGED DACHSHUND

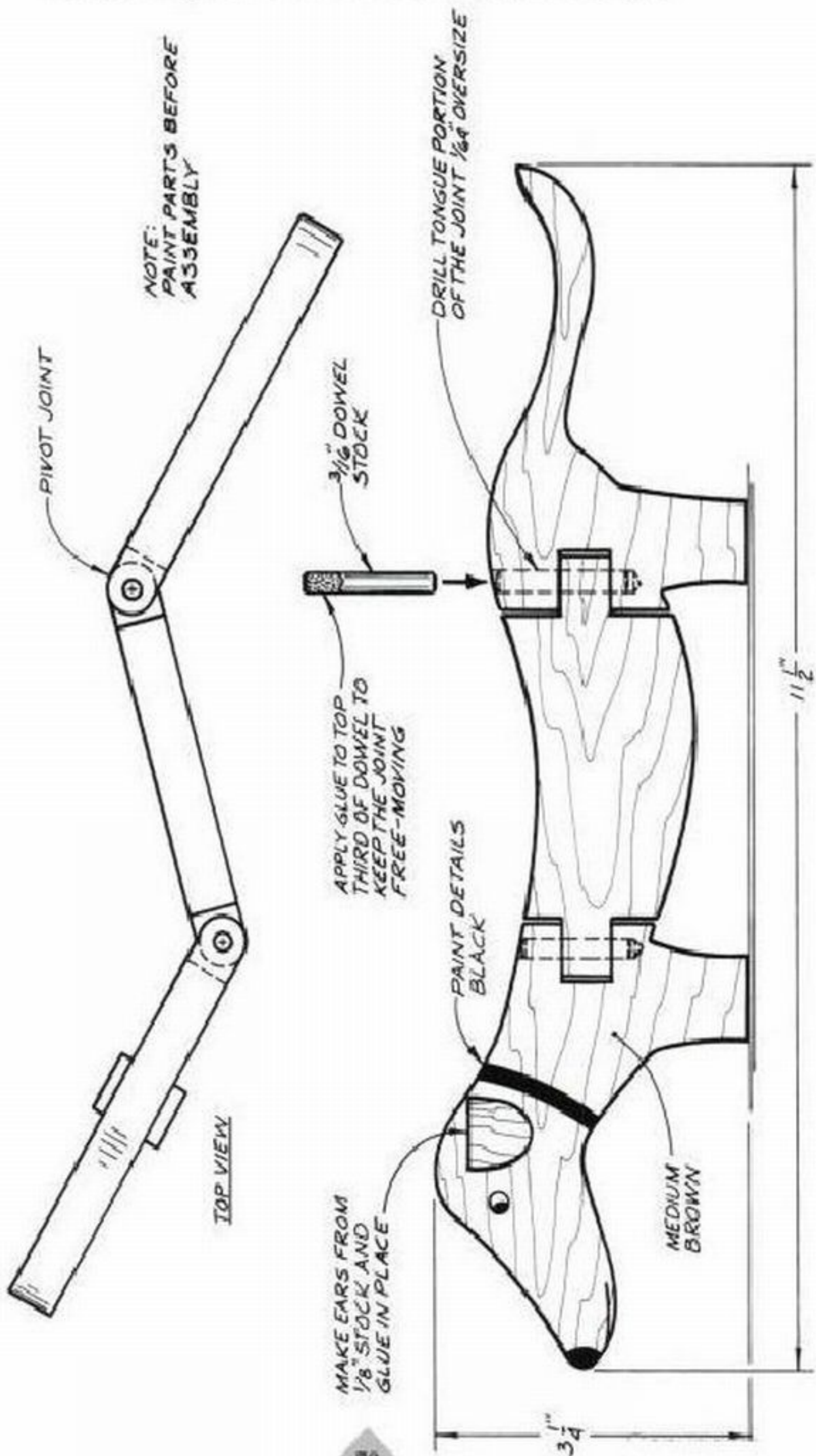

FULL-SIZE PATTERNS

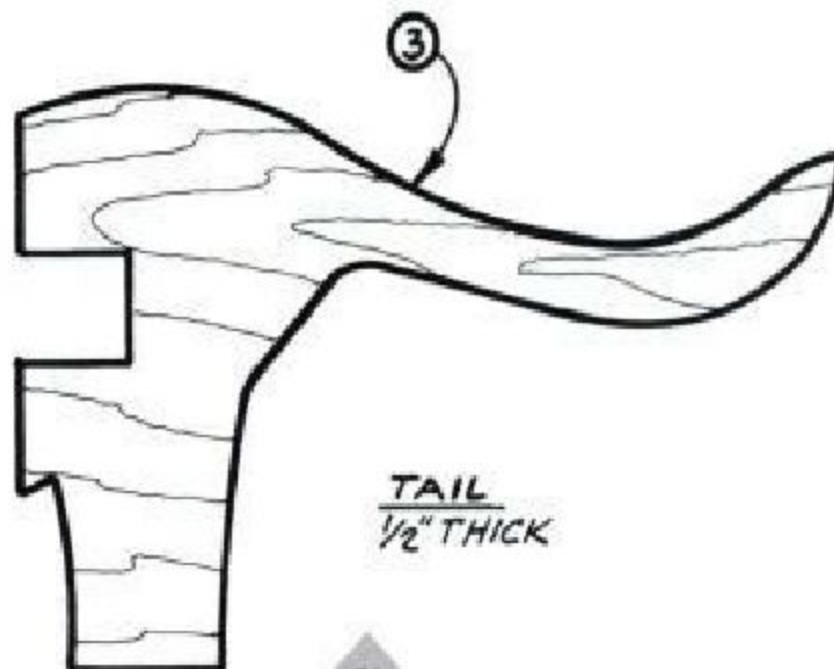
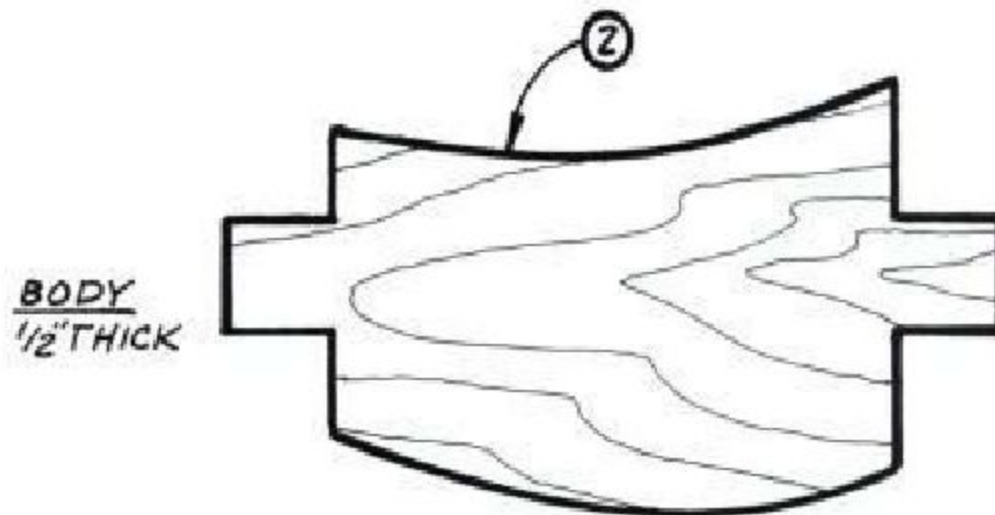
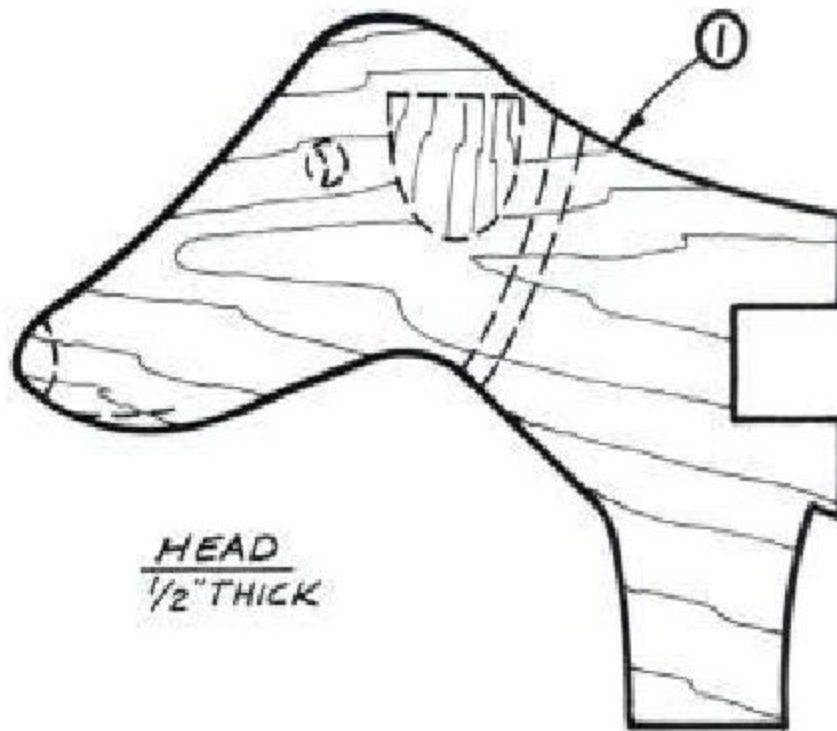

BEETLE

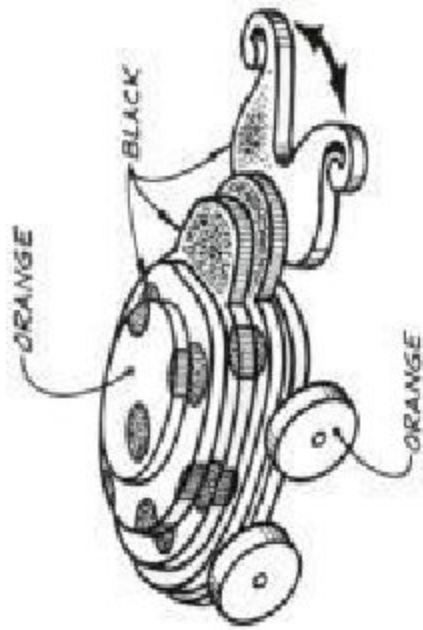
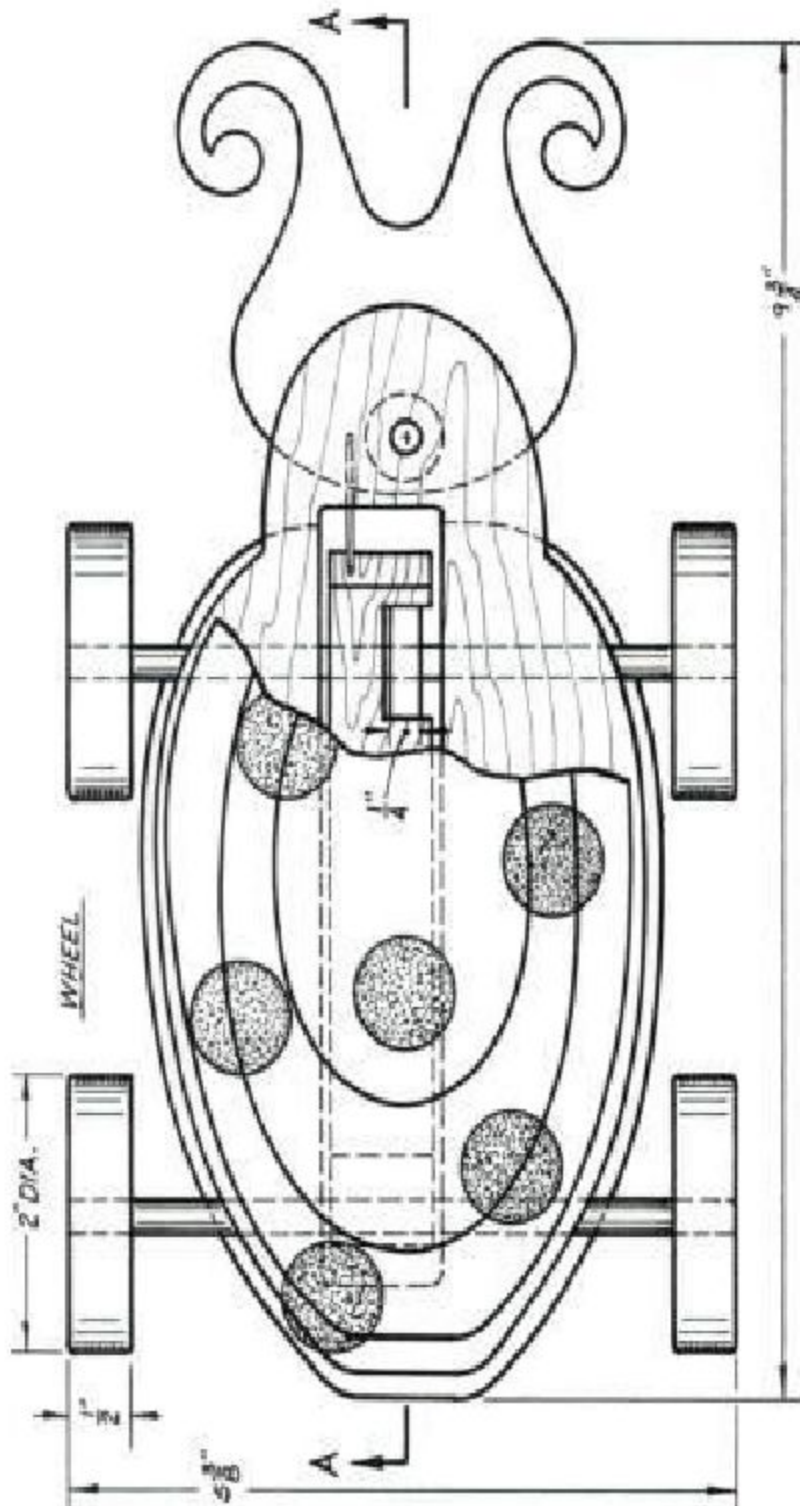

TOY'S ACTION

ROLLING MOTION CAUSES THE BEETLE'S FEELERS TO MOVE FROM SIDE TO SIDE

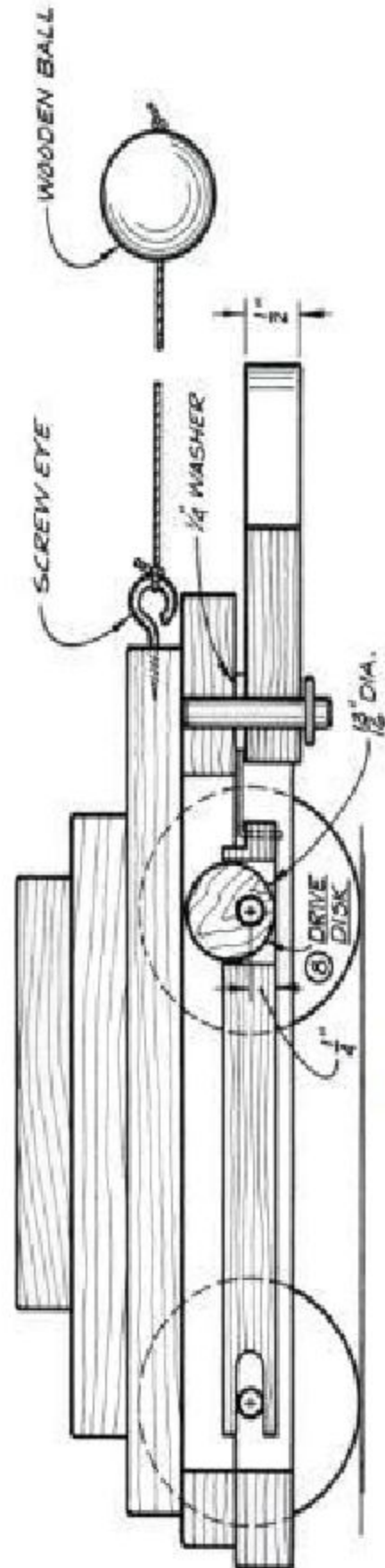

AA SECTION VIEW

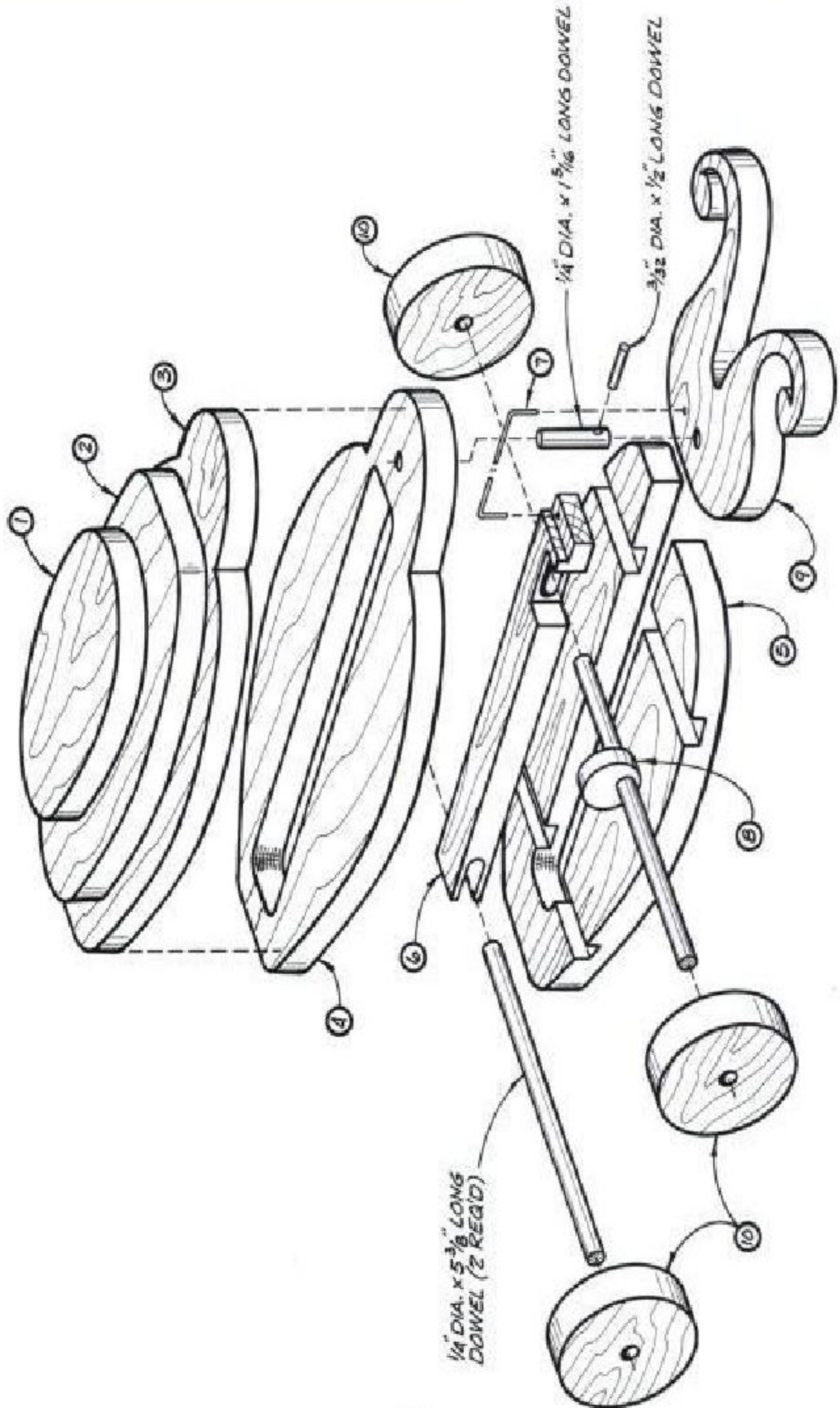

BEETLE
FULL-SIZE PATTERNS

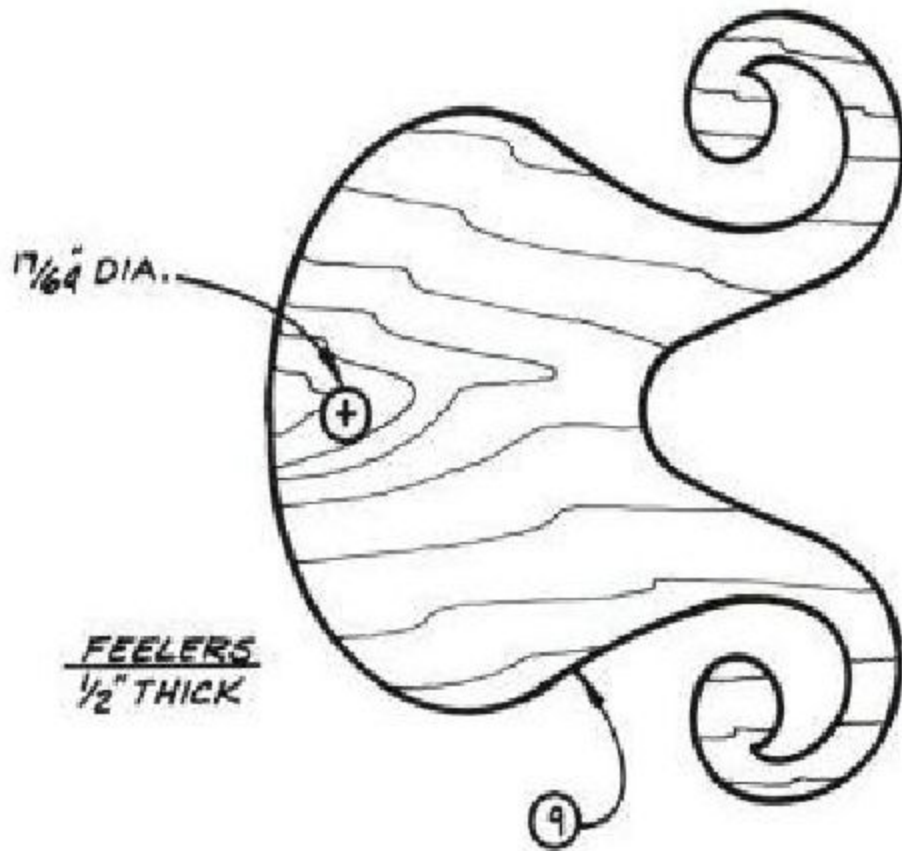

① ② ③

UPPER BODY
PARTS
1/2" THICK

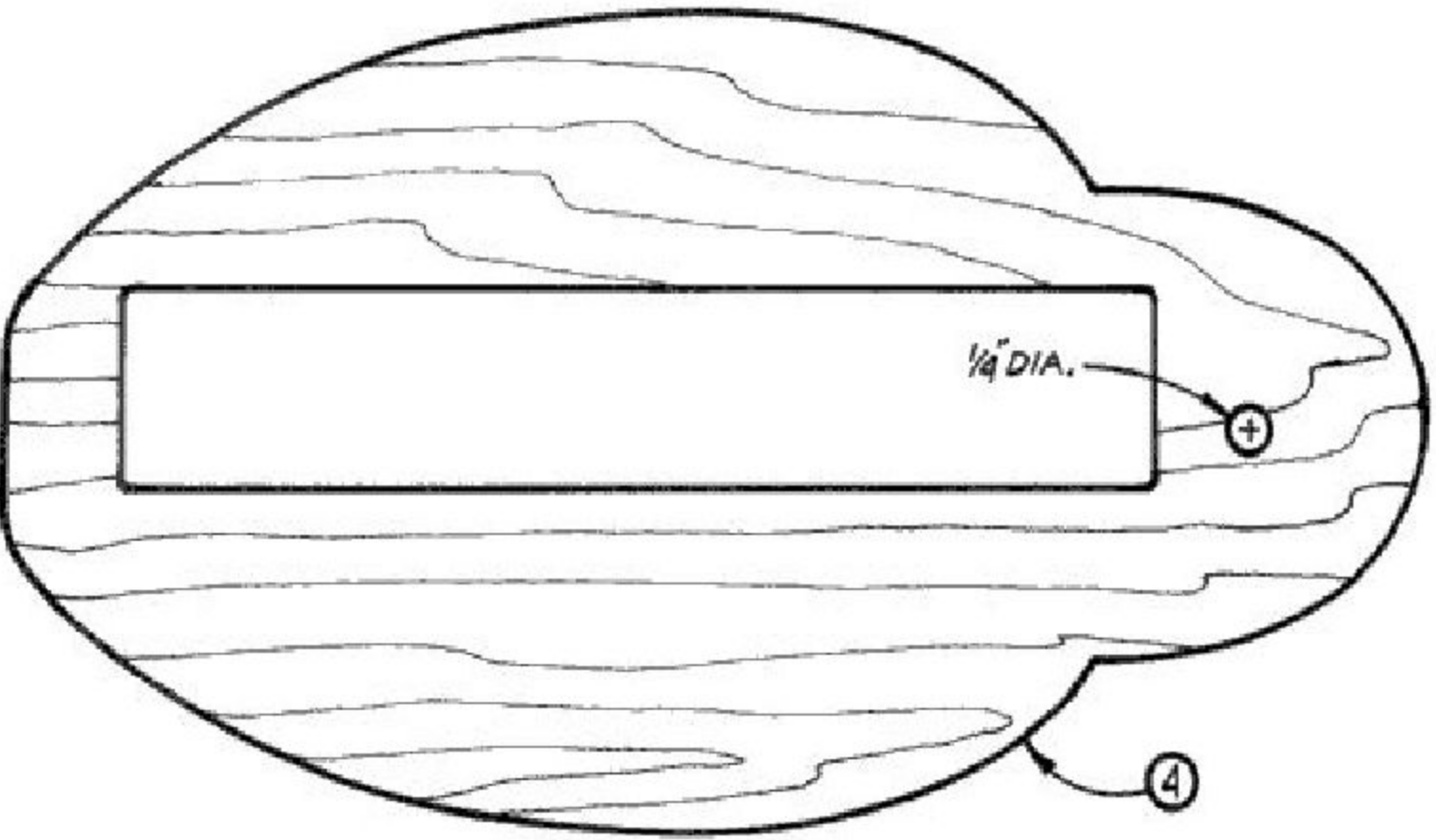
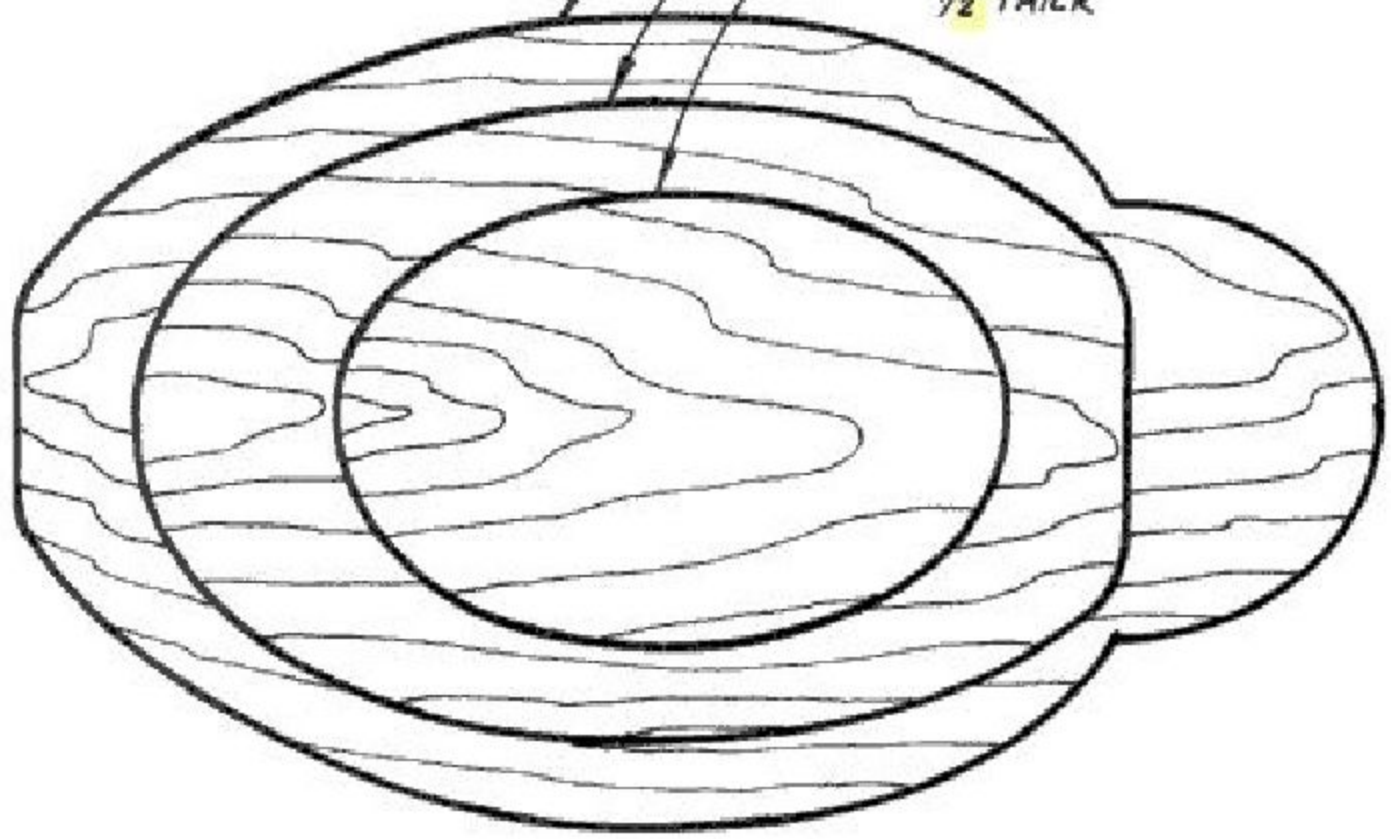

MIDDLE BODY
1/2" THICK

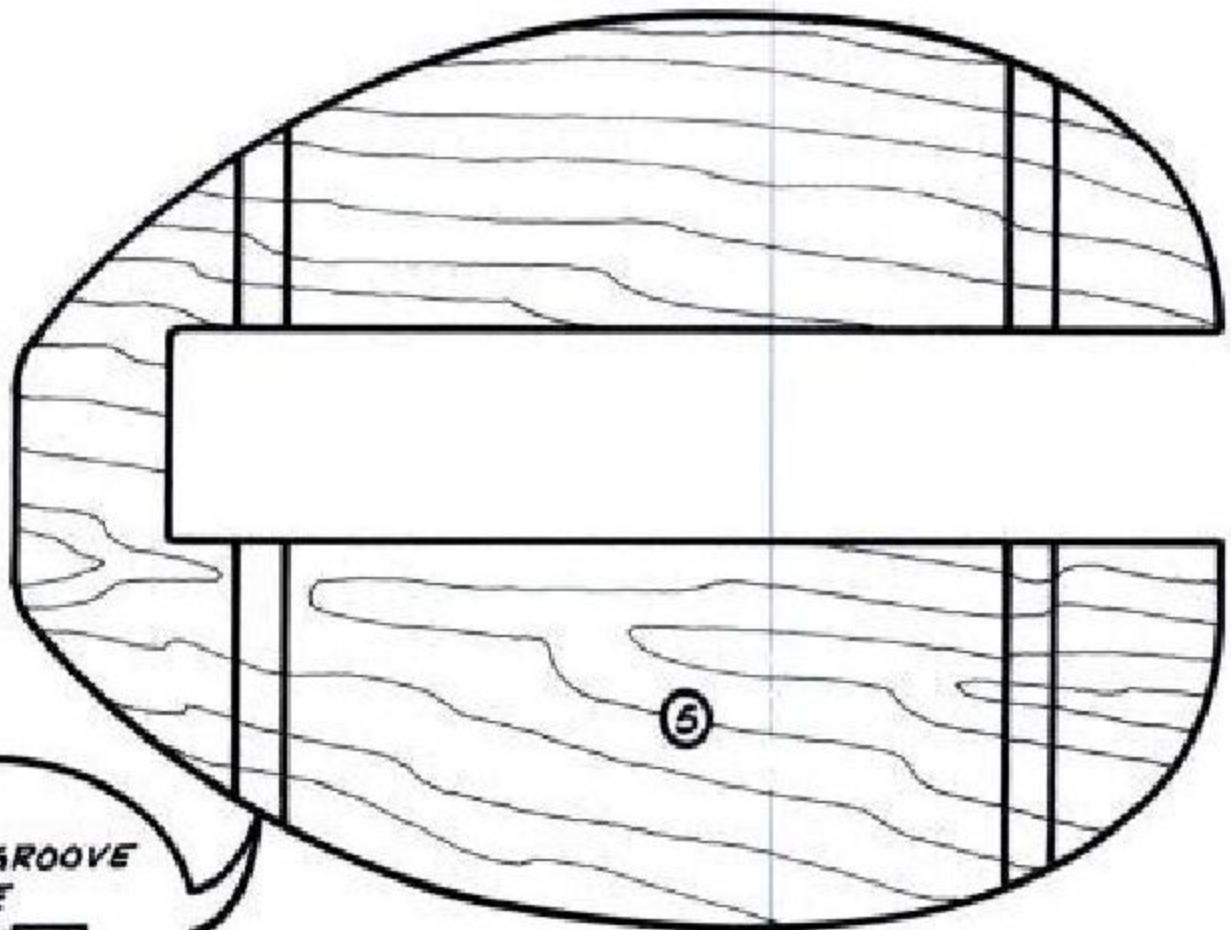

LOWER BODY
1/2" THICK

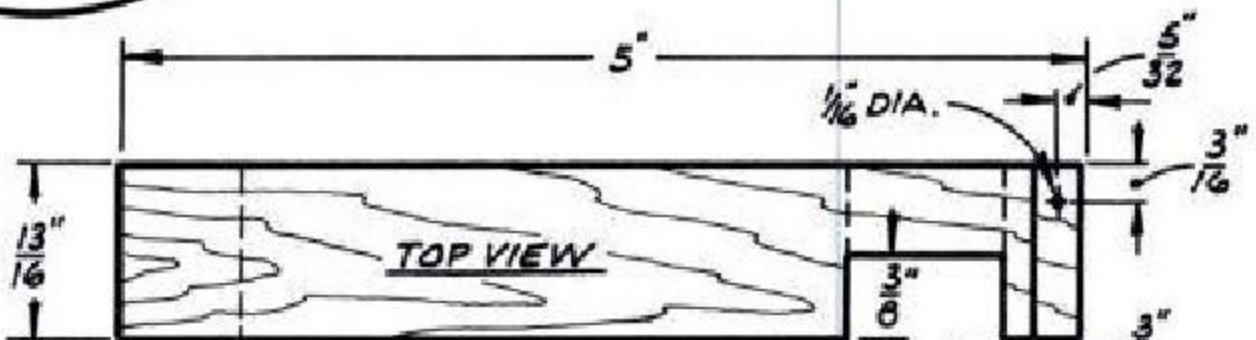

TOP VIEW

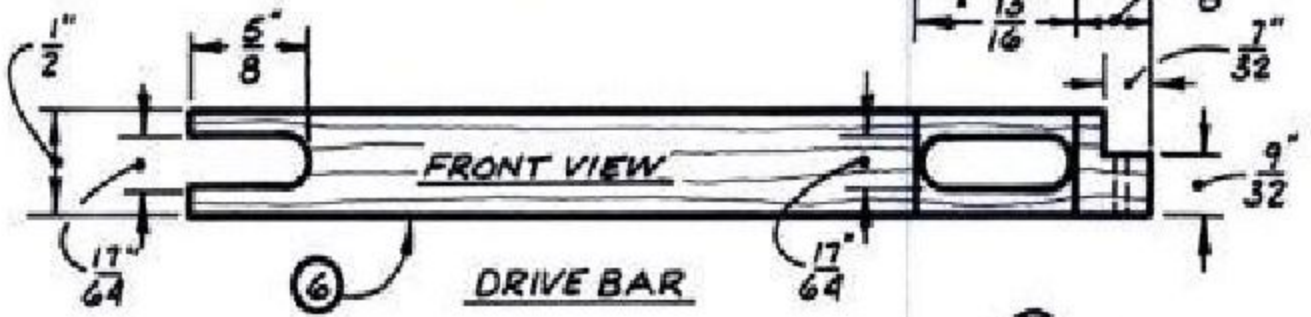

FRONT VIEW

DRIVE BAR

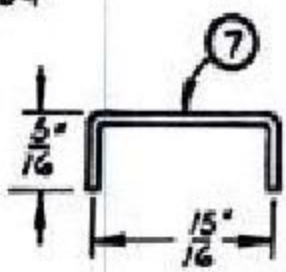

DRIVE ROD
3/64" DIA. MUSIC WIRE

BEETLE
FULL-SIZE PATTERNS

For additional patterns,
try these other scroll saw books from Stackpole . . .



CLOCKS

Full-Size Designs, Ready to Cut

Offers detailed patterns for exquisitely crafted timepieces, many based on antique originals. Includes designs for shelf clocks, wall clocks and a weather station. \$14.95



EASY CLOCKS

Full-Size Designs, Ready to Cut

Amusing and imaginative, the patterns in this book include a teddy bear clock, a football helmet clock, a cat clock, and an elegant Victorian silhouette clock. \$14.95



FANCY FRETWORK

39 Full-Size Designs, Ready to Cut

Contains intricate patterns for a variety of decorative and practical household items, such as trivets, plant hangers, mirrors, shelves, clocks, and picture frames. \$14.95



LETTERS AND NUMBERS

Full-Size Designs, Ready to Cut

Use these designs and typeface styles to make signs for the front yard, bookends for your office, personalized toys, decorative plaques for special occasions, and more. \$14.95

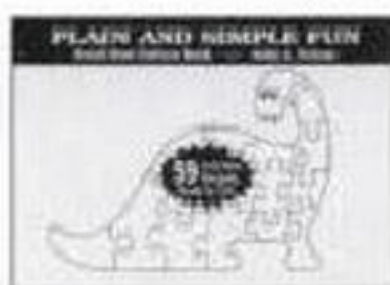

PLAIN AND SIMPLE FUN

59 Full-Size Designs, Ready to Cut

Animal cutouts, wall plaques, puzzles, and pull toys are but a few of the many projects in this book. Give them as gifts to children or to any person who enjoys good ol' fun. \$14.95



TRAINS, PLANES, AND AUTOMOBILES

Decorative Designs, Ready to Cut

Features patterns of classic cars, famous planes, and historic steam engines. Cut them out and start a collection. Use them as knick-knacks or wall plaques. \$14.95

5067 Huber Road, Mechanicsburg, PA 17055 • 800-732-3669
e-mail: sales@stackpolebooks.com • www.stackpolebooks.com

**STACKPOLE
BOOKS**

Also from Ken Folk . . .

COUNTRY TOYS & CHILDREN'S FURNITURE

*Antique Designs with Complete
Plans and Instructions*

With the detailed plans and easy-to-follow instructions provided in this book, you can recreate enjoyable toys, games, and play furniture from the past. Eighteen delightful projects are included:

- Small Child's Chair
- Doll Cradle
- Small Wagon
- The Acrobat
- Marble Solitaire
- Nine Men's Morris
- Rocking Horse
- Eighteenth-Century Cradle
- Play Wagon
- Rolling Horse
- Ring Toss
- Pigs in Clover
- Diablo
- Twirler Tops
- Three-Wheeled Doll Pram
- Child's Rocker
- Military Drum Toy Box
- Child's Sled

\$19.95 • PB • 192 pages • 11 b/w photos • 167 drawings • 8 x 11 • 0-8117-2428-X

5007 Riner Road, Mechanicsburg, PA 17055 • 800-732-3900
e-mail: sales@stackpolebooks.com • www.stackpolebooks.com

STACKPOLE
BOOKS

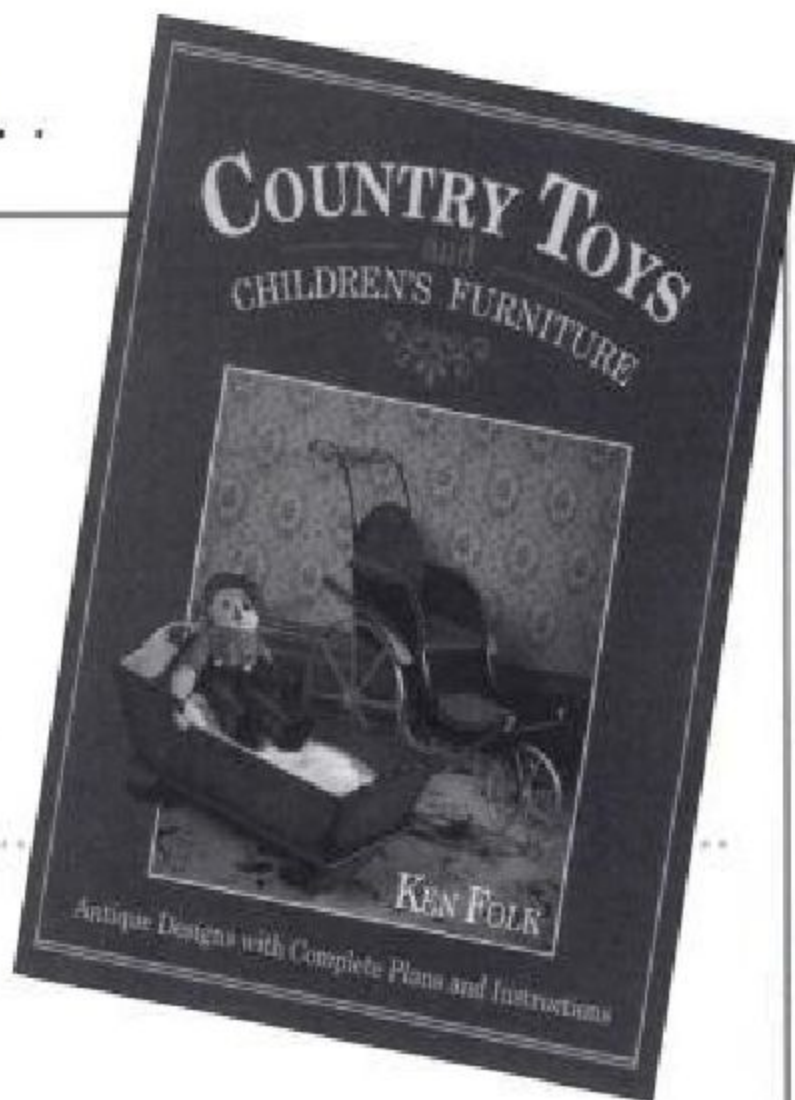

With a scroll saw, some scrap wood, a touch of paint, and this book, you can create fascinating, movable toys from the past. Full-size patterns and plans for 19 pull-cord, hand-crank, and gravity-operated classics are offered. You'll find a waddling shorebird, diving frog, strutting pig, creeping crocodile, scuttling beetle, and more than a dozen other toys that crawl, push, pull, rock, roll, bob, leap, spring, pivot, plummet, and zigzag.

KEN FOLK, an engineer and woodworker, is author of *Country Toys and Children's Furniture*.

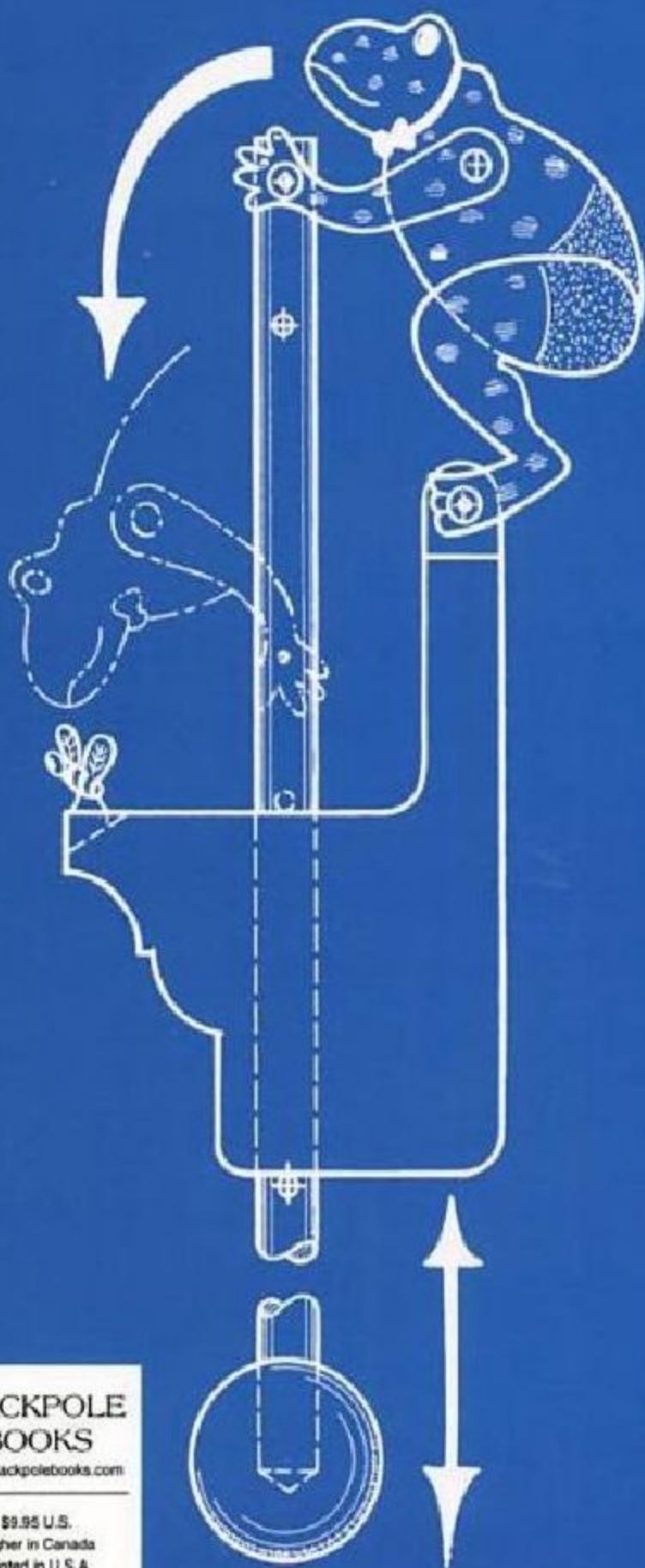

ISBN 0-8117-2920-6



9 780811 729208

90000>



**STACKPOLE
BOOKS**

www.stackpolebooks.com

\$9.95 U.S.
Higher in Canada
Printed in U.S.A.