

# Carving Netsuke

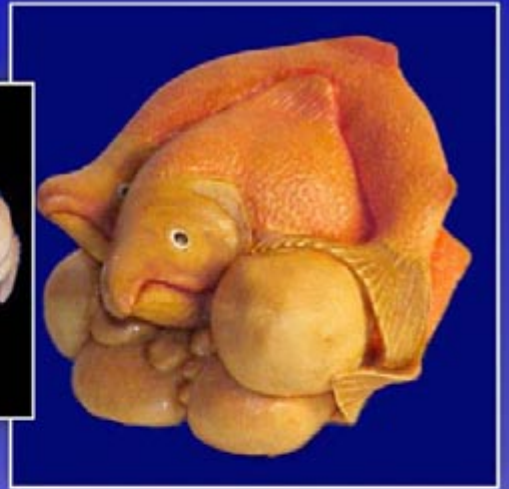

## The Miniature Sculpture of Japan



## Ancient Traditions, Modern Methods

by Tom Sterling  
Second Edition 2006

# CARVING NETSUKE

## The Miniature Sculpture of Japan Ancient Traditions, Modern Methods

**Second Edition 2006 by Tom Sterling**

Copyright © 2006 Thomas J. Sterling, Jr. All rights reserved. No part of this publication may be reproduced, stored in a retrieval system, or transmitted, in any form or by any means, graphic, electronic, mechanical, photocopying, recording, or otherwise, without the prior permission of the copyright owner. The purchaser of this publication may, for personal use only, produce hardcopy output or otherwise reproduce the carving patterns contained herein for the purpose of personal and non-commercial carving of the subjects. Persons conducting carving classes for the purpose of carving education may likewise reproduce the carving patterns for use only as class carving projects.

Second Edition Published August 2006, First Edition Published March 1994

Foredom™ is a trademark of Foredom Corporation.

Deft™ is a trademark of Deft Corporation.

Adobe™ is a trademark of Adobe Corporation.



Note the netsuke and pouch worn by the attendant.



My Old Office...

# Table of Contents

About the Author	6	Hair and Fiber	36
Introduction	6	Oblong cuts	36
What is a Netsuke?	8	Dimple Texture	37
Why Such an Exciting Art Form?	9	Small Raised Dimples (Lizard Scales)	37
The netsuke "Formula"	9	Punch textures	39
Equipment	11	Short knife cuts	40
Power Carving Tools	11	Hair and Fiber Textures	41
Rotary Hand Pieces	11	Wire brush Texture	41
Rotary Cutters	11	Oblong cuts	41
Rotary Finishing	13	Combined Texture Techniques	41
Knives, Chisels and Scrapers	16	Shadow	41
Netsuke Carving Materials	20	Making and Inlaying Small Wood Eyes	42
Ivories and Ivory-like	20	Round Eye Inlay	45
Corals, Stones	20	Cat or Reptile Eye Inlay	47
Ceramics and Metals	20	Pitfalls to watch out for	49
Boxwood	21	Fitting Pieces Together	50
Ebony (Gabon)	22	Dental Amalgam Inlay	51
Desert Ironwood	22	Gold and Silver Leaf Inlay	52
Lignum Vitae	22	Making Barnacles	52
Holly	23	Ukibori Bumps and Warts	53
Hawthorn	23	Wood Ukibori Techniques	54
Fruit and Nut Woods	23	Ivory, Bone and Metal Ukibori	55
Basswood	23	Adding Elements to Carvings: Ladybugs	56
Ivory	24	Some other ladybugs	58
Elephant and Fossil Ivory	24	Carving the Spawning Sockeyes Netsuke	76
Hippopotamus teeth	25	Inlaying Thin Elements	123
Bone	25	Errors and Common Mistakes	142
Antler and Horn	26	Filling holes and correcting errors	142
Antler	26	Common Mistakes by Novice Carvers	143
Horn	30	Finishes	143
Ideas, Subjects, Research and Design	32	Polishing	143
Ideas and Subjects	32	Silver Nitrate	143
Research	32	Ivory Finishes	144
Design	33	Wood Finishes	144
How long do carvings take?	33	Mini-Project: Practice Cuts	146
General techniques of power carving	34	Project: Carving the Duck Decoy	147
Work Holding	34	Project: Carving the Sleeping Mouse	156
Texture and Shadow	36	Pyrography and Small Carvings	161
Dimples (holes)	36	Project: Carving the Baby Sparrow	177
Small Raised dimples	36	Netsuke Patterns	184
Punch textures	36	Snail on a Bucket Netsuke	184
Wire brush	36	Manju Netsuke	186
Short knife cuts	36	Crab in a Bucket	187

# Table of Contents

## Netsuke Patterns (continued)

Crab in the Weeds	188
Hatching Dragon	190
Octopus in Basket	192
Hermit Crab	193
Octopus on Broken Pot	195
Sometimes the Dragon Wins!	196
Wasp in Gourd	197
Hatching Alligator	199
Assorted Patterns Yet to Carve	202
Netsuke: First Night Out	206
Netsuke: Chickadee and Pinecone	208
Netsuke: Cloud Dragon	208
Netsuke: Diving Helmet	209
Netsuke: Haida Harvest	209
Netsuke: Humpback Whale	210
Netsuke: Sea Nettles	211
Netsuke: Praying Mantis	213
Netsuke: "The Old Ones Gather Firewood"	214
Netsuke: "Pitcher Thief"	215
Netsuke: Yin/Yang Stingrays	215
Netsuke: Fugu (Japanese Puffer Fish)	216
Netsuke: Box Turtle	217
Netsuke: Brother Cellarer	218
Netsuke: Bumblebee on Blackberry	219
Netsuke: Calimari and Prawn	220
Netsuke: Chickadees in a Nest	221
Netsuke: Cicada on Curled Leaf	222
Netsuke: Crab Kagamibuta	224
Netsuke: Crab Kagamibuta	225
Netsuke: "Spring Phlox" in the Snow	226
Netsuke: Crab in an Oyster Shell	227
Netsuke: Dead Duck Decoy	229
Netsuke: Entwined Fate	230
Netsuke: Tree Frog on Mushrooms	231
Netsuke: Wormy Garlic	232
Netsuke: Hermit Crab	233
Netsuke: Inro, Netsuke and Ojime Suite	234
Netsuke: Golden Crowned Kinglet	235
Netsuke: Woodworking Plane	238
Netsuke: "Puget Sound Symphony"	240
Netsuke: Washtub Pumpkins	241
Netsuke: Pygmy Owl	242
Netsuke: Seahorses	244

Netsuke: Siamese Fighting Fish	245
Netsuke: Spanish Dancer	247
Netsuke: Twins	248
Netsuke: Golden Orb Spider	249
Netsuke: Shrimp	250
Ojime: Cicada	251
Ojime: Frog on Branch	252
Ojime: Fugu	253
Ojime: Ladybugs	253
Ojime: Blackberries	256
Ojime: Sea Nettle	256
Ojime: Spider and Web	257
Miscellaneous Carvings	257
Inspiration Pages	258
Ox, by Ryuun	258
Goat, unsigned	266
Rat on Lotus Root, unsigned	267
Monkey, unsigned	271
Tiger and Monkey, by Ran	272
Tiger, unsigned	273
Tigers, unsigned	274
Sea Horse, unsigned	275
Centipede on Rock, unsigned	275
Snail Ryusa, unsigned	276
Hawk Manju, unsigned	276
Blind Men on Plank, by Ikkosai	277
Dancer, by Minkoku	278
Robber on Log, unsigned	279
Wise Man with Scroll, unsigned	280
Gamma Sennin, unsigned	280
Root netsuke, unsigned	281
Pea Pods	282
Frog and Basket	283
Okimono	284
Miscellaneous Items:	286
Press Molds and Precious Metal Clay	286
Carving Porcelain Netsuke	292
Floating Treasures	310
Elegant Display and Presentation Box	314
Making a Buckskin Pouch	322
Medicine Pouches	342
Carving Bird Skulls	351
How To Identify Different Kinds of Ivory	357

# Table of Contents

Tools List_____	357
Bibliography and References_____	358
Contemporary Netsuke Carver Web Sites____	359
Good Netsuke or Carving Web Sites_____	359
Sources of Supply_____	360
About This Book_____	361

## About the Author

Tom Sterling was born in Texas and raised everywhere else. After many years of service with the US. Air Force, he now carves wood full time as his excuse for not getting a real job. A member of the Dayton (Ohio) Carver's Guild, Tom began carving as a Boy Scout at the age of 10, and with the exception of a 9th grade art class, is completely self taught. During his first assignment in the Air Force, he discovered Japanese netsuke at the DeYoung Art Museum in San Francisco. Subsequent assignments in England further advanced his interest in netsuke when, by constantly browsing antique shops, he was able to accumulate a small collection of his own. In 1986, as netsuke prices began skyrocketing and rapidly became a rich man's game, he began carving his own. With few books available to help, he experimented for several years to reproduce many of the techniques of the ancient netsuke masters, and has updated many to modern methods and tools. This book is his first attempt to pass on his skills to those who wish to take up this fascinating and unusual hobby.

## Introduction

This book is not intended to teach you to carve; rather, it is intended to teach you to carve netsuke. If you are a beginning carver, please refer to one of the many good books on basic carving techniques to learn how to properly use and sharpen your power tools, knives, and chisels. We will be exploring the techniques I have used successfully after several years of experimentation and self-teaching, as well as techniques from the Japanese masters themselves, albeit somewhat altered for modern tools and materials. Some of these techniques are fairly advanced, but I have no doubt that even a beginning carver can master them with some practice. Not every netsuke requires them all, so the beginner can produce good carvings without having to master all the advanced techniques. We will be using power tools for the majority of our work, but will also revert to knives and chisels for some tasks, especially in the finishing stages. Once you've mastered the techniques presented here, you'll be able to apply them to any type of carving. Besides netsuke, I've used them to produce necklaces, decorated jewelry boxes, and carved walking sticks. There's no end of eye-catching sculptural and decorative items you can produce.

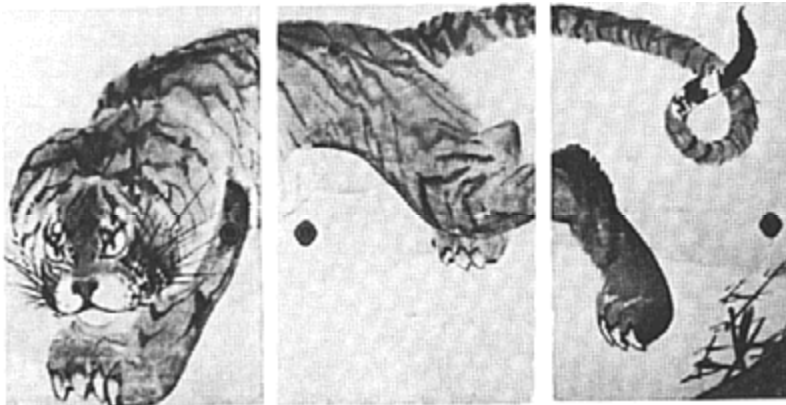

# SAFETY FIRST, SAFETY ALWAYS!

Please read, understand and use all the safety procedures that the manufacturer recommends for your power tools. There is no more important safety procedure than ALWAYS, ALWAYS, ALWAYS wearing safety glasses or goggles! Rotary carving tools operate at speeds up to 20,000 rpm, and some of the newer ones operate at 35,000 and even 70,000 rpm. Pieces of cut material or disintegrated bits leave the grinder at extremely high speeds, and can easily do permanent damage to your eyes. The quickest way I can think of to spoil a great hobby is to be seriously injured by it!

Also, for use with knives and chisels, I strongly recommend using one of the cut-resistant gloves available on the market today, made with Kevlar™ or steel wires. However, I recommend you do not wear these gloves while operating your rotary grinder using the common small rotary bits and burrs. The weave of the cut-resistant gloves is likely to snag the bits, causing them to wind up into the material, yanking the tool out of your carving hand, and possibly doing more damage than without the gloves. Many of the bits are small enough to get between the weaves and contact your skin beneath. If you wish to wear gloves while using the rotary carving tools, I recommend sturdy leather work gloves; they won't snag as badly,

Many exotic woods and materials are toxic if their dust is inhaled, so be sure to wear a well fitting and effective dust mask, especially when using the rotary carving tools. A dust collector is also useful. Materials like ivory have been known to transmit diseases like anthrax, and while this is quite rare, at least be forewarned and wear a dust mask. Other animal materials like horn, bone, and antler may have similar hazards.

Some of the finishing methods I'll describe use materials or procedures that are very flammable, and have toxic or noxious vapor properties. Be sure to use them only in well-ventilated areas, with proper fire extinguishing equipment immediately at hand, and according to the manufacturer's safety recommendations. Also, linseed oil, contained in many of my primary finishes, is subject to spontaneous combustion if you leave oily rags lying around. Please dispose of them properly --- I burn them in a safe manner immediately after use.

# SAFETY FIRST, SAFETY ALWAYS!

**What is a Netsuke?** Netsuke (pronounced “net-ski” or “net-skay”) are an ancient Japanese art form, of tiny size and incredible beauty and detail. Netsuke wearing was popular from 1603 to 1912. Netsuke wear gradually declined as the Japanese began adopting western-style dress after Commodore Perry’s “visit” in 1853 ended Japan’s self-imposed centuries of isolation. In the 18th and 19th centuries, the dress of the day lacking pockets, people carried a small box consisting of several sliding drawers, called an inro, to contain their sundries. The inro was the Japanese version of a wallet. These drawers were strung on a loop of cord and slid up under the sash of the kimono. A decorated bead called an ojime was strung on the cord to snug up the inro drawers and keep them closed. A large button or toggle was fastened at the end of the cord to keep the cord from sliding out from under the sash. It was this button that eventually developed into the lovely netsuke we see today. Each netsuke is characterized by holes or openings (the “himotoshi”) in the design for the cord to pass through. Naturally, the early plain buttons became increasingly decorative, and eventually became one of the ways people displayed their status in the community. Japan had severe laws preventing open displays of wealth, and the netsuke was the perfect way of demonstrating your wealth and status, in a distinct but unobtrusive (and legal) manner.



on a loop of cord and slid up under the sash of the kimono. A decorated bead called an ojime was strung on the cord to snug up the inro drawers and keep them closed. A large button or toggle was fastened at the end of the cord to keep the cord from sliding out from under the sash. It was this button that eventually developed into the lovely netsuke we see today. Each netsuke is characterized by holes or openings (the “himotoshi”) in the design for the cord to pass through. Naturally, the early plain buttons became increasingly decorative, and eventually became one of the ways people displayed their status in the community. Japan had severe laws preventing open displays of wealth, and the netsuke was the perfect way of demonstrating your wealth and status, in a distinct but unobtrusive (and legal) manner.

Netsuke became more and more elegant, with a netsuke carved by a famous artisan sometimes costing the owner as much as a lavish house. Netsuke became popular for carrying tobacco pouches and pipe cases, purses, and anything else which

might be suspended from a cord. Often, the netsuke and inro were subject and color-coordinated, and were made of an enormous range of different and precious materials. The most common netsuke seen today are carved from lovely hardwoods or ivory, although precious metals and stones, lacquer, horn, deer antler and pottery aren’t uncommon.

Typical netsuke have several features in common. They are very compactly designed, with no sharp protruding parts to catch on expensive clothing or break off. They are carved on all sides, top and bottom.



They were designed to be handled; for all their small size and extreme detail, they are surprisingly sturdy. My universal experience with netsuke is that they all feel good when handled. They fit in your hand comfortably, and most are between one and three inches in size. Many have literally survived centuries of use and abuse; in fact, the most beautiful examples are worn quite smooth, and take their beauty from ages of the wear, dirt, grime and skin oils we now call patina. I find this to be one of the most attractive parts of carving netsuke. The carver is not the ultimate end of netsuke production, because the owners impart a style of their own through handling and wear. My favorite antique netsuke are those which are the most worn, showing they were cherished possessions and part of the owner's everyday life. The Japanese carved an astonishing array of subjects, ranging from mythology and religion to everyday objects and animals. Today there is a growing movement of contemporary netsuke carvers. Most are Japanese, but there are also surprising numbers of Western carvers in many countries around the world. Some even make their living by netsuke carving. With this very short explanation of the history of netsuke art, I've barely scratched the surface. For additional information about netsuke, see the references at the end of this book. Many of these books may be available at your local library.



Attendant with tobacco pouch and ojime

### What Makes Netsuke Such an Exciting Art Form?

A netsuke offers a format for the artist to portray, in full sculptural form, an astonishing array of subject matter, including (but not limited to) legends, folklore, history, studies of animals, flowers, insects, mythological creatures and more. The viewer enters a magnificent miniature world, where philosophy, customs, and culture are conveyed through the art form, captivating in its whimsy and incredible beauty. More fascination is added by the variety of style which ranges from the intensely realistic to the abstract and surreal. However, the most unique quality of a netsuke is its appeal to the sense of touch. Netsuke are sculptural masterpieces which have all the power and attraction of full size sculpture, yet, they can be held in the hand. Upon handling a netsuke, there is an intimate physical and often spiritual interaction which is not present in other art forms.

### The netsuke “Formula”

Because of its derivation from a functional object, the creation of a fine netsuke poses a tremendous challenge to the artist. Designs have to be compact, without sharp or protruding edges, which would either snag a beautiful silk kimono, or break off in use. There should be openings (himotoshi) for the cord to pass through, carefully placed so the netsuke would hang attractively when worn. The netsuke should also balance when it is being displayed as a fine piece of sculpture. Netsuke should feel good when handled and

should be carefully finished and be aesthetically appealing from every angle, including upside down.

To fully appreciate the attractiveness of netsuke, we must visit a uniquely Japanese concept of beauty, **Shibui**. Beauty in Japan is sometimes expressed in levels, from brash and glaring to the most attractive of subtle elegance. Shibui is the quality of beauty that doesn't need announcing; its qualities speak for itself. The literal translation carries the meaning of the puckery and astringent qualities of the green persimmon. This meaning is symbolic and carries the idea of something not sweet in nature, but rather one that is reserved and somberly austere in its effect. The artistic meanings of shibui relate to the simple yet refined characteristics and to the subtle and restrained nuances found in a work of art. The concept of Shibui relates to great reserve in works of art or in other aspects of the visual world around us. It reflects something of what in the West is called "good taste." By far the best and simplest definition is "quiet elegance." This simple elegance is what attracts us to Japanese art. Interestingly, Japanese youngsters have appropriated the word to mean "cool" or "rad."

Some authorities make the claim that prior to the mid-1850s (Commodore Perry's visit) the Japanese language had no word for "art." Odd that a culture where even the most mundane objects were constructed to reveal their functional beauty, a culture where most objects were beautiful, had no concept of "art for art's sake." The West had, for thousands of years, produced art objects which had no particular function beyond being aesthetically pleasing, while Japan apparently had no such idea. The Japanese apparently had no need for a formal concept of "art," because they did not separate useful things from beautiful things as the Western world does. While objects were painstakingly altered to be beautiful, each thing had a practical function beyond just looking good. Netsuke are the perfect concept illustrating this. Beautiful in and of themselves, they served a practical purpose.

## Equipment

The traditional method of carving netsuke primarily involved tiny knives, scrapers, and chisels. The netsuke carver occasionally used saws and large bladed knives, but these were mainly used in the roughing out stages. I'm well aware of the controversy today between the "traditionalist" woodcarver who uses only "hand" tools for carving, as opposed to the power carver. Obviously, all of these tools were hand powered. I'm always amused by the arguments of the traditionalist who only uses knives and chisels, but often roughs out blanks with a jig or band saw. Certainly not traditional hand tools in my book! I believe that the traditional carvers used the best tools their technology had to offer, and would certainly use modern methods were they alive today. In addition, I believe a carver should strive to produce the best art they can, and I believe power tools allow carvers to produce designs that can only be executed at great difficulty and risk with traditional hand tools. However, if you wish to carve using traditional methods, then go for it! Netsuke carvings were made perfectly well in pre-industrial revolution feudal Japan, so they can certainly be produced without power tools of any kind. The carving of your original masterpiece is the point, not the methods of execution. All the designs I present in this book can be executed without power tools, and only the speed of completion will suffer. I personally use a Foredom™ rotary grinder, and I've also used Dremel™ tools with excellent results. Any of the rotary tools on the market that can generate at least 10,000 RPM should work just fine. Variable speed control (I like the foot operated version), while not required, is often very useful. I get bored easily, so I use the tool that achieves the desired results quickly.

## Power Carving Tools

### **Rotary Hand Pieces**

I use four different types of hand pieces with my Foredom™: the large bore collet hand piece for roughing cutters with 1/4 inch shafts, a similar key-tightened hand piece for 1/8 and 3/32 inch cutters for general work, a pencil hand piece for detailing and operations requiring fine control, and a hammer hand piece for texturing. I have several of each type, but there is no requirement for using this many. I've simply acquired them over the years for convenience. I started out with just the key-tightened hand piece, and used it successfully for many years. You can certainly do just as well. If you haven't yet acquired a rotary carving tool, I suggest a multi-use hand piece be your first purchase. The others can come along later as you gain in skill.

### **Rotary Cutters**

I've acquired more than two hundred cutters, bits and burrs over the years, and have found that only rarely do I use more than a few types and sizes. Often specially shaped cutters in the catalogs look attractive, and seem as if they'll be useful, but often turn out to be good for one task only. The types I find I use the most are BALL or EGG SHAPED cutters, from large, to small, to extremely tiny.

I use a large selection of ball cutters. My cutter stand currently has 20 in it, although a few are duplicates. I have more in reserve. The largest have 3/4 inch diameter cutting heads with 1/4 inch shafts, used for roughing out. The size I use most often is 1/8 inch diameter, and the smallest about the thickness of a coarse hair. The smaller sizes come with shaft diameters of 1/8 inch and 3/32 inch. The 3/32 inch shafts

are fine for the smaller diameter cutters used for fine detail, but if used for heavy cutting they often vibrate and chatter severely, causing a rough finish. For those used for general cutting, you should get 1/8 inch shafts. Cutters like these are available through most wood carving supply catalogs. A good source for the smaller sizes of cutters is through your local dental supply house. Not all ball cutter sizes are available in tungsten carbide (usually referred to as just plain “carbide”), especially in the tiny sizes, but where it is available I recommend you spend the extra money and get carbide rather than steel. Carbide will far outlast steel, and the harder woods, bone, and ivory you’ll be carving will dull high-speed steel in a single heartbeat. These rotary cutters are almost impossible to sharpen.

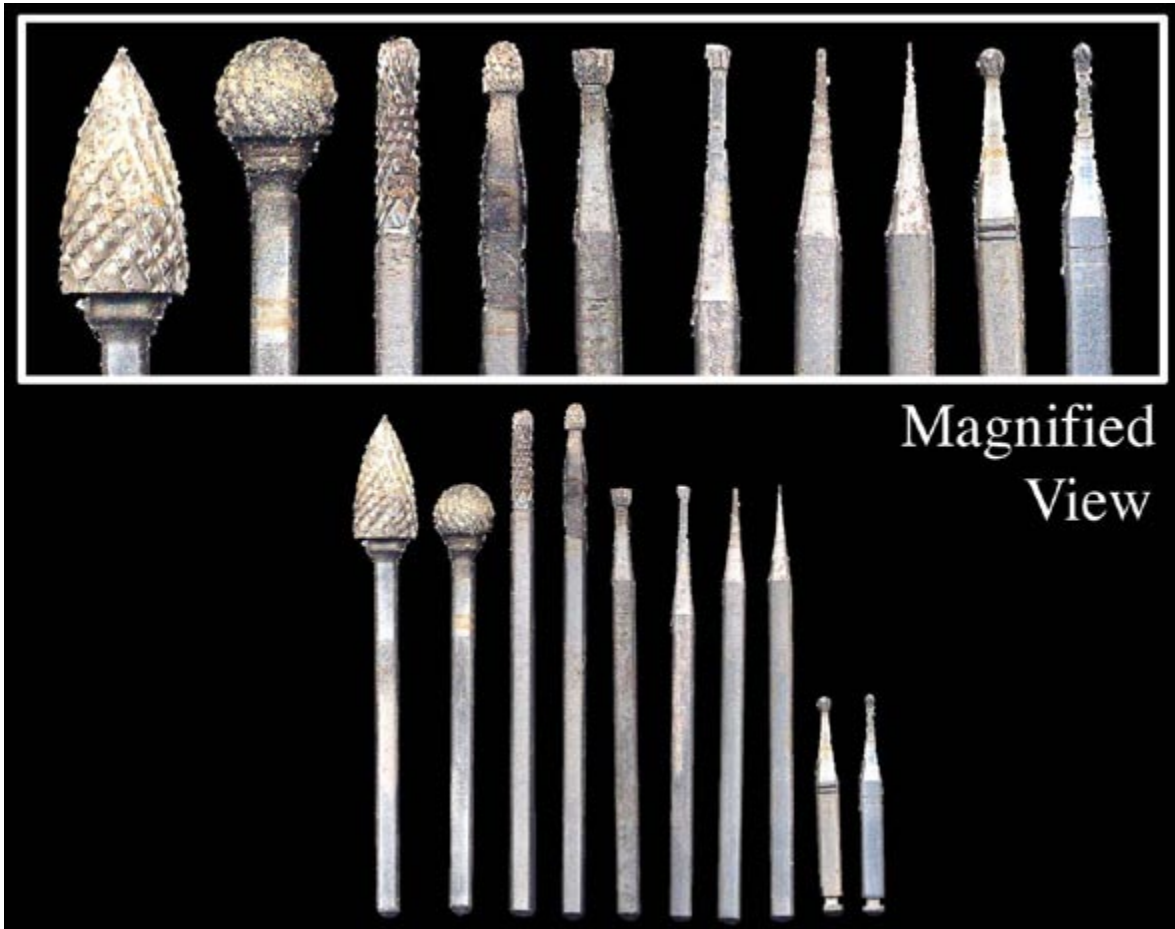

**Hint:** Sometimes a dull cutter can be useful in the finishing process, especially with lighter colored woods. When used at high speed, they will slightly burn the wood and give your cuts additional contrast.

The other shapes (not shown here) are also occasionally useful. The barrel shaped cutters are used for general roughing out and areas where a 90 degree corner or shoulder is. The flame shape has a sharp point

for detailing, and can also be used for general carving over areas with broad curves, since its edge curve isn't as pronounced as a ball cutter's. The inverted cone can be used for less than 90 degree sharp corners and shoulders, and for undercutting. There are also abrasive ruby cutters available through wood carving supply firms. These are available in similar shapes and sizes as the cutters above, and in two grades: coarse and fine. They work quite well for a number of types of wood, and can be used for smoothing and texturing as well. They are especially useful in tight and delicate places where controlled cutting is required. The coarse versions cut surprisingly quickly. The ball and flame shapes in 1/4 and 1/8 inch sizes are the most useful.

I survived for years on cutters from 1/4 inch diameter and less, and so can you, at least during your early experiments carving netsuke. The following cutters are useful, but fairly expensive and not essential. I would wait to buy these as your skills increase, and your pocketbook can stand the strain. I've found that the 1/4 inch shafted carbide cutters (same shapes as the cutters above), with up to 3/4 inch diameter cutting heads are useful for early roughing out, as well as the structured carbide burrs with hundreds of needle-like teeth. They both remove waste wood very quickly.

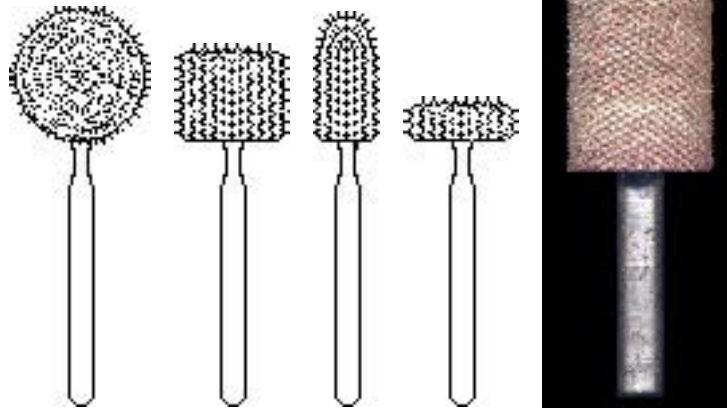

## WARNING

**Structured carbide cutters make huge clouds of dust, so definitely wear your dust mask! Many of the exotic woods you may be carving are toxic, and the structured burrs make large quantities of extremely fine airborne particles.**

## WARNING

### Rotary Finishing

I use a great variety of rotary finishing aids, many of them homemade. Some of them are adapted from jewelry making tools and techniques. First off, however, let me say that with careful carving you should

require relatively little smoothing and finishing. The standard finishing techniques using sandpaper only will be all too obvious. Even the tiniest of sandpaper scratches can be easily seen when your carvings are examined as closely as is typical for carvings as tiny and detailed as netsuke. I try to leave the surface as smooth as possible using just rotary cutters, detailing chisels, and tiny scrapers. From there I use abrasive finishes (like sandpaper) only if necessary for further smoothing. If I've been careful enough I won't require sandpaper and can go on to polishing. If I do need sandpaper, I use only paper as fine as 220 grit and finer. Often, I'll cut out a piece of sandpaper about 1 1/2 inches square, punch a small hole in the center, and mount it between two small washers on a general purpose mandrel for use in my rotary tool.

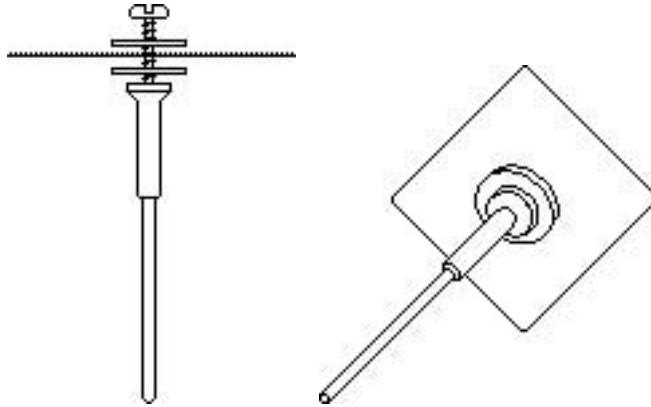

The picture shows an exploded diagram of a mandrel with sandpaper between washers. Be sure to tighten the screw down for actual use. While the sandpaper disk starts out square, it will soon become round with use. The sandpaper doesn't last long, but is cheap and effective. For sanding large areas, a more durable type of sandpaper can be found by using drywall sanding screen, available at your local hardware store. Drywall sanding screen is used in housing construction, and looks like screen window mesh covered in abrasive. It cuts quickly, and at low speeds is flexible and conforms to contours of the work piece. At high speeds, the rotational force is so great that the screen or sandpaper disk acts as if it is quite stiff, and will not conform to the contours. Try using it at various speeds. Once you have the surface very smooth, either straight from the cutting tools or after using progressively finer grades of sandpaper, the work piece is ready for polishing.

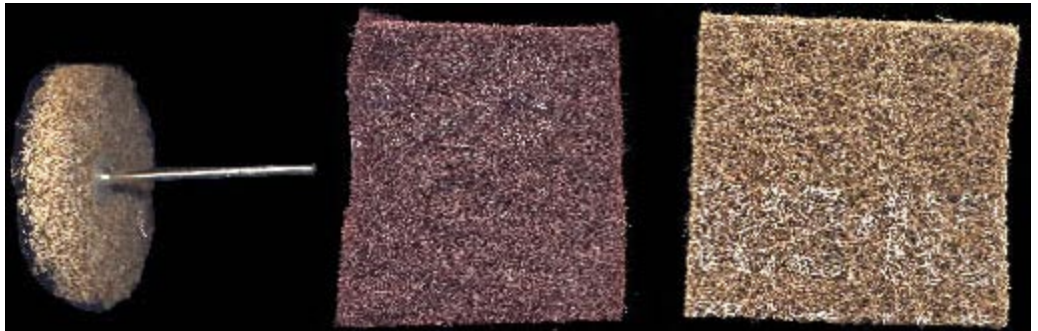
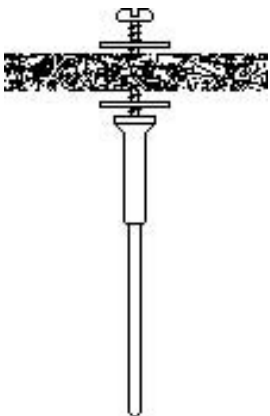

For final "sanding" I use abrasive polyester fiber pads on a mandrel just like the sandpaper disk. These

pads look much like a sponge, and are about 1/4 inch thick. One brand called ScotchBrite™ seems to be commonly available, made by 3M™ corporation. It is available in several grits, starting about where very fine sandpaper leaves off. It's used for final wood smoothing before painting, and there is a version for metal polishing and smoothing. I use the coarse (olive drab color) and the medium (maroon color). The other grades I don't like: either they don't do anything on the hard materials netsuke carvers use, or they leave color behind. You'll generally find abrasive polyester fiber pads in the paint or sandpaper department of the hardware store. The pads will leave the harder woods with a lovely smoothness, and even a sheen from polishing. Cut pieces about 1 1/2 inch square and mount on a general purpose mandrel between two small common washers. The more abrasive grades can remove fine detail if you're not careful, so approach your work with care. As the pads wear down, be sure to replace them before the mandrel parts or the washers can come into contact with the work piece and scratch it. Watch out so the material doesn't snag projecting pieces of the work and break them off or yank the piece out of your hand. **Eye protection and dust mask are absolutely required here!**

For very small areas, I have a set of diamond points in various shapes. They are used for carving fine detail and for smoothing. They come in many shapes, but I find the small ball and flame shapes the most useful. They sound expensive, but aren't really, especially considering they'll never wear out if used strictly for carving wood. Don't try to use them at very high speeds because they are likely to burn the material you're trying to shape and smooth. Medium speeds work best. If the points begin to accumulate a glaze of abraded material on them (called loading up), then soak them in turpentine or paint thinner.

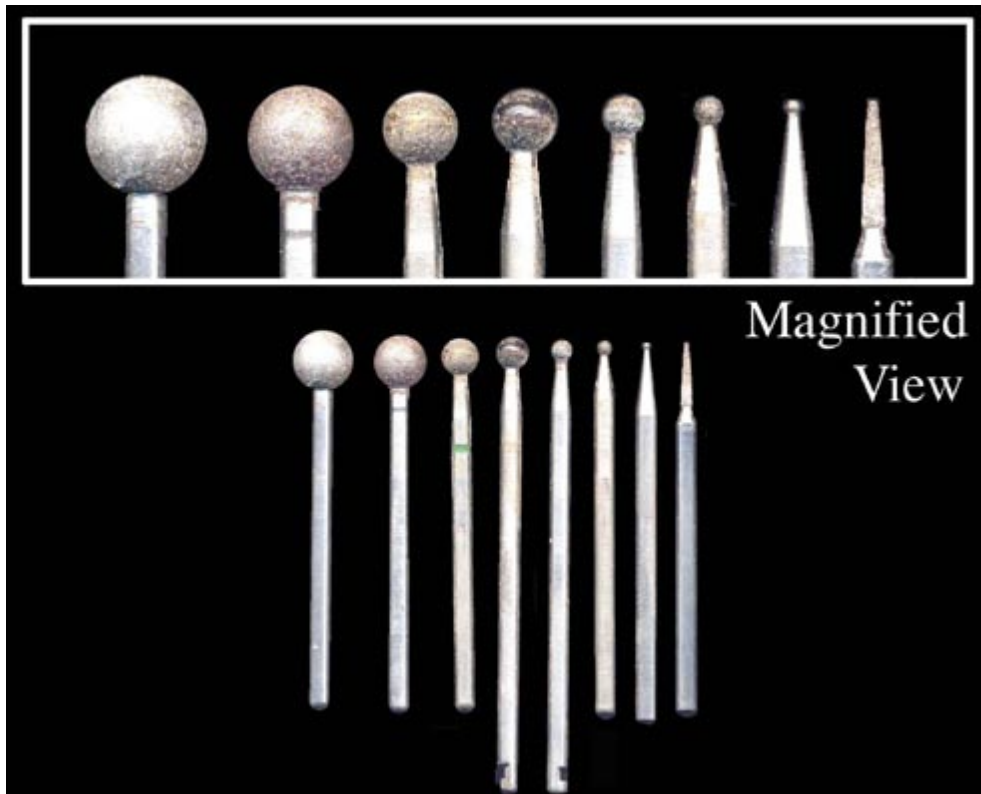

I try to match the steel and carbide burr shapes and sizes with diamond or ruby burrs. Above are my dia-

mond burrs, with one ruby (second from the left). Notice they're all ball shaped with the exception of the ling, skinny tapered burr on the right, and the 4th from the left needs deglazing.

**CAUTION: Advertisers say the structured carbide cutters can be burned free of glazed wood. I have done that for difficult cases. Don't try that with diamond abrasive points; diamond may be hard, but it is just organized coal and burns just like it. I suspect thermal shock would ruin your ruby carvers as well, and high-speed steel will lose its temper and dull instantly.**

**Hint: When working in "gooey" woods or other materials that tend to load up the burrs with sap, I keep my structured carbide cutters, diamond and ruby carvers in turpentine while I'm using them. As I need one, I simply take it out of the turpentine, rub it with a wire brush to remove the build up, and dry it with a paper towel just before use. Spray type oven cleaners also work quite well to clean out the goo. I place the cutters in a jar, spray liberally with the oven cleaner and let sit for several hours, then wash off with water.**

Once the piece is as smooth as you can get it with tools, sandpaper (if required) and the polyester abrasive pads, then apply the finish. Once dry, I generally begin polishing with muslin buffs. These look like circles of white cloth stitched together in a stack, and about 1/4 inch thick. They come in several sizes, and I prefer those about 1 1/2 inch in diameter. In addition, for very hard woods, there are also some felt buffs available, which come in both hard and soft varieties. The hard types are useful for polishing large smooth areas, but are prone to burning the surface if used too long in one spot or at too high a speed.

A valuable adjunct to sanding is the popsicle stick or tongue depressor. I glue various grades of very fine emery paper to tongue depressors with white glue to sand hard to get at places and large smooth surfaces. I once read somewhere that the only way to get something really round was to sand it with something flat. Strange as it seems, I have to agree, and the popsicle sticks really work well for that. Not only can they work on large areas, but when you really need to get them into a tight area, they can be cut down with a knife into the shape you need. Just don't use your good carving blades to trim the abrasive stick with; the emery paper will dull them in a hurry.

### **Knives, Chisels and Scrapers**

For many years I made do with the limited knives and chisels I could find or make. My smallest chisels were adapted from old dental tools and ground down allen wrenches, or manufactured from high carbon steel piano wire (available at hobby shops). I spent many hours grinding and shaping these tools, and many more hardening and tempering them.





**Hint: For homemade tool handles, try using hardwood “shaker” pegs as handles (like the top chisel above), available from better woodworking stores and lumber suppliers. They come in convenient sizes and comfortable shapes.**

Then, I discovered a set of tiny woodworking chisels used for micro detailing. With those discoveries, my knife and chisel worries were over. Of all I’ve mentioned, I find these the most useful. Definitely start with a set of these. I advise getting the smallest (advertised as the 1 1/2 mm set), and the largest (the 3 mm set) for starters. These chisels come as square, skew, gouge and v-tools. Expansion sets are available with several other shapes and sizes, including dogleg chisels. Without small tools like these, good netsuke carving is nearly impossible.



Straight Chisels of 3 sizes (above)



**Skew Chisels (above)**



**Gouge (top) and V-tool (bottom)**

I use these types extensively to place a fine, dark shadowed line to separate portions of carvings, like the area where an arm contacts the body when held tightly against it. Fortunately, when they do break, only the tiny tip is damaged and is easily replaced by sharpening. Since the points slope down, they tend to dig into the carving surface. I use them by controlling how much I allow them to dig-in, often resting the bottom of the shaft on portions of the carving. I use the contact area as a fulcrum for leverage to control the amount of dig-in. The real secret (of course!) is to practice.



I also find scalpels useful for some parts of a carving. The replaceable blades (I like the #11 thin, pointed blade best) always allow me to have a sharp one available without my having to sharpen them. Be sure to get the small #3 scalpel handle for use with the #11 blade. The #11 blade won't fit on the larger #4 handle. If you can't find a source for scalpels, hobby knives will work as well. There is a similar #11 blade available in the hobby knife line.

Since the carving materials I like to use are very hard, I often find it more expedient to use scrapers than knives. I make my own scrapers from sharpened dental tools. Your dentist may have old ones to give you, if you ask nicely. If not, they are available from dental supply houses, and sometimes from carving supply catalogs. Also, I've found some custom made small knives I have become addicted to.

Below they're shown with several pieces of plastic tubing from the hardware store I slip over the business ends to preserve my fingers when the knives aren't in use.



**Note: There are some dental tools that look more like tapered, bent wire, and are round in cross section. Those are not the ones to use; they can't be sharpened into scrapers.**

The bottom tool (shown in top and side views) has a leaf-shaped end, and one that is round. Their faces are flat, and I sharpen all sides. The hook-shaped tool is triangular in cross section on both of the business ends, and I sharpen the inside edges of the hooks. Since these are scrapers, I find it useful to burnish the edges with a hard piece of steel (usually I use the smooth end of a small drill bit). Burnishing will cause the fine edge of the dental scraper to curl over slightly and improve its cutting action. Don't remove the wire edge from sharpening and burnishing. Scrapers require this tiny, rough wire edge to cut with.

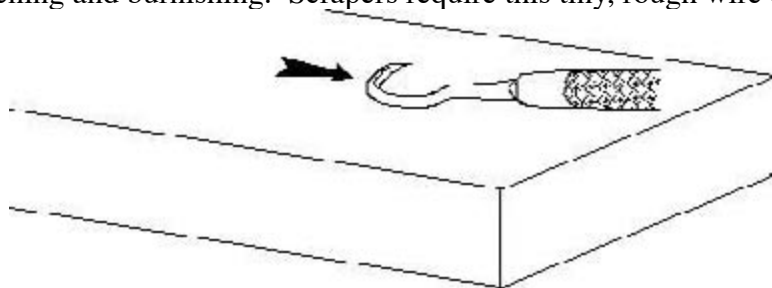

Another makeshift tool I find useful is one of the ruby carvers or diamond abrasive bits held in a pin vise.

By choosing a bit of the right shape, you can use it to smooth many areas where conventional sandpaper or polyester pads simply can't reach. It's simple, effective, and cheap.

## *Netsuke Carving Materials*

The traditional materials of netsuke carving are as diverse as imagination can make them. They include many of the woods carved today, plus an incredible number of other precious, semi-precious, and common-place substances. Here is a short list of materials to stimulate your imagination. The best advice I can give you is to innovate and experiment.

### **Netsuke Carving Materials (a short list!)**

#### **Woods**

Boxwood, ebony, cherry wood, plum wood, pear persimmon, holly, desert ironwood, Lignum Vitae, yew, rosewood, bamboo (especially roots and the thick section at the base of a bamboo stalk), vegetable ivory (corozo/tagua nuts), semi-fossil woods (millennia-old wood from peat bogs, called umoregi in Japanese), fruit pits and nuts

#### **Ivories and Ivory-like**

Elephant ivory, fossil mastodon and mammoth ivory, whale tooth ivory, walrus tusk ivory, fossil walrus tusk ivory, hornbill casque ivory, hippopotamus tooth ivory, boar tusk ivory, bone, horn, antler, rhinoceros horn

#### **Corals, Stones**

Red coral, black coral (called umimatsu in Japanese), marble, semi-precious stones (jade, agate), amber, glass

#### **Ceramics and Metals**

Pottery, porcelain, gold, silver, copper and their alloys, iron, pewter

Just to mention a few I've carved: elephant ivory (from antique billiard balls), hippopotamus ivory (antique sources also), antler (naturally-shed), boxwood, ebony, lignum vitae, desert ironwood, tulipwood, Mayan bloodwood, holly, and naturally occurring tree oddities, like burls and knots. All the animal products I use are from recycled antiques, or non-lethal harvest from non-endangered species.

**Note: Elephant, whale, walrus, and hornbill casque ivory are governed by the International CITES treaty and national regulations concerning possession, transportation, and sale of animal products from endangered species. Use with caution. Better yet, use fossil ivories instead.**

Of the woods, there are only two requirements; they must be very hard, with very tight grain and few pores.

The harder the wood, the better I like it. Of course, I do most of my carving with power tools. If you are just using hand tools, you may want to rethink this strategy. Use the really exotic woods with showy colors judiciously. Not only may they be from threatened and endangered species, but the wild colors and patterns may detract from your design. Also, their grain may be very erratic. This isn't much of a problem for power tools, but hand carving will be doubly difficult. Although woods with open pores are not suitable for extreme detail, in some cases you may wish to use open grain woods like oak or rosewood to achieve a particular textural effect. Use your imagination!

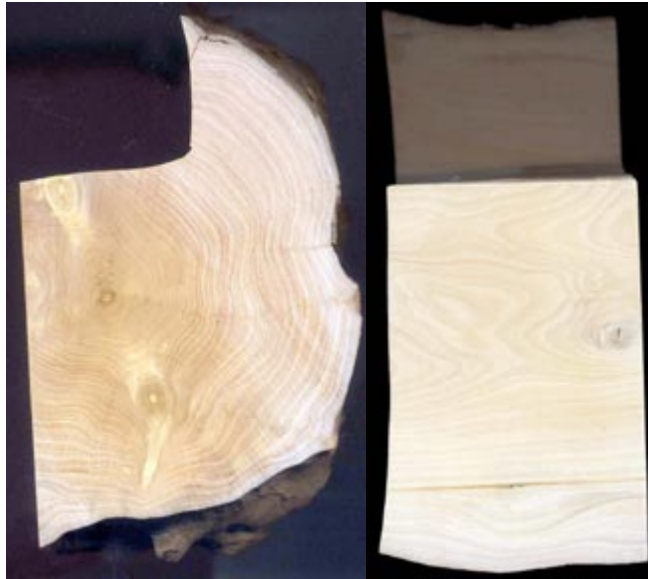

### **Boxwood**

The ultimate wood for highly detailed carving, and by far my favorite. It is a tan to yellow wood, moderately hard, with extremely fine texture and virtually invisible structure. Boxwood isn't brittle, and holds crisp detail while carving very smoothly. Boxwood grows as a bush (the very same bush as in your hedge)

or small tree (in the wild), and seldom attains a trunk size greater than 6 inches, so don't expect to find enough to carve a life-size cigar store Indian. It has done everything I've asked of it. Boxwood has a pleasant smell during carving, reminiscent of baking peanuts. Since it has such tight grain, it doesn't take stains terribly well without resorting to extreme measures like long soaking or boiling. See the section on finishes. Hardwood retailers with large selections can probably order it for you, but it is expensive. I obtained a log of it about the size of a man's leg for \$166.00 in 1993. Of course, a piece that size is enough material for many netsuke!

### **Ebony (Gabon)**

This dense, black wood is my second favorite, next to boxwood. If you need a black wood, this is the one. It is very dense, with fine texture, holds detail well, and carves well with power tools. True ebony will be jet black in color with occasional brown streaks. Many types of wood on the market are sold as ebony, like Macassar ebony, but don't have the same qualities. Ebony is brittle in small, thin sections, but I have never had any difficulty with it. Ebony polishes well and tools leave it quite shiny. Ebony is very available, although somewhat expensive, and is usually stocked by better hardwood retailers.

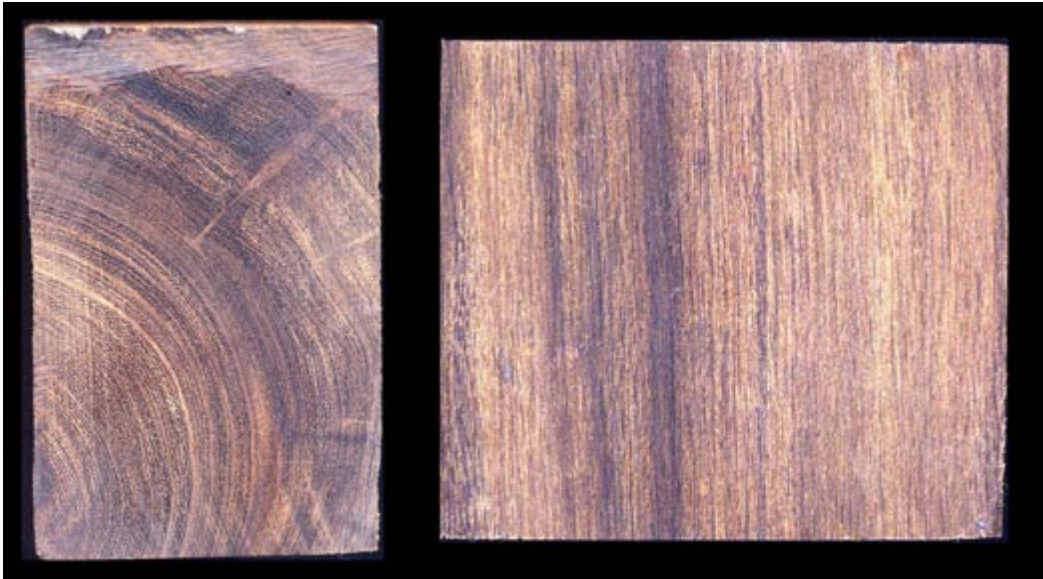

### **Desert Ironwood**

A dark brown wood from the desert southwest of the United States and Northern Mexico, it is as dense as any wood I've found, and carves well with power tools. It can be a problem with knives, as it tends to produce chips rather than shavings, and can be brittle. When used with oil finishes is very dark brown with little visible grain. Unattractive smell during power carving, and I've heard it is one of the more toxic and allergy-causing woods - definitely wear a dust mask! Edged carving tool cuts will usually leave a surface sheen. I've seen this wood for sale mostly at rock and gem shows.

### **Lignum Vitae**

It is an attractive medium to dark brown, often in streaks. Lignum Vitae is very hard, and quite oily, making gluing a bit difficult - I recommend epoxies only. When using rotary burrs I notice the wood comes off in

tiny fibers, but isn't brittle. Many times has attractive grain variations and patterns. The wood polishes well and edged cutting tools leave it with a sheen. It is expensive, sometimes stocked by better hardwood retailers.

### **Holly**

A white, very hard wood, with little grain, no open pores. Holly carves and takes stains well and is useful for extreme color contrast effects with multiple woods and materials. It is my second choice material for barnacles on marine subjects, after ivory. I cut my own from ornamental shrubs.

### **Hawthorn**

I've heard it is close to boxwood in carvability, but have never used it. Hawthorn isn't available commercially, but can be found in woods and in the green spaces along roads and fields.

### **Fruit and Nut Woods**

Cherry, pear, plum, apple, citrus woods, etc. You should also investigate nut woods like almond (but not walnut or pecan). Most are hard and have a tight, attractive grain with few open pores. Some of the more familiar woods like walnut are too soft, and the grain is too open for most netsuke designs. I've carved pecan, and it seemed too brittle to me. Olive wood is a creamy white with dark streaks and nice, close grain. Cherry is available at most hardwood retailers, and I've occasionally seen pear as well. The others may be available locally in firewood piles in regions where they grow.

### **Basswood**

For the experienced folk-art carver addicted to this stuff, I've included this one. Forget it. Basswood is far too soft, it will damage easily (remember, netsuke are to be handled!), it won't hold good detail in the tiny sizes netsuke are carved in, won't take a polish, and tends to fuzz badly when carved with rotary cutters.

Other suitable woods of many colors and grain patterns are too numerous to mention, and your local hardwood retailer will have many to select from. Just remember the basic rules of tight grain and hardness, and you aren't likely to go wrong. Always be on the lookout for good netsuke material, especially in your day-to-day activities. Remember, netsuke don't take much wood, so you can often find useful pieces overlooked by others. Especially be on the lookout for ornamental trees and shrubs growing locally; they are often of small size, but quite often contain very striking netsuke wood. If you see someone working in their yards and trimming bushes, take a look at the wood. It may just pleasantly surprise you. Several interesting woods I've come across in the back yard are camellia and lilac. Don't overlook your and your neighbor's firewood piles. Also, be on the lookout for burls growing on trees and shrubs. Even open-grained woods often have beautiful tight-grained areas where burls form. Small burls also make interesting free-form netsuke subjects, often suggesting the subject when you see them. I made an attractive netsuke that looked like a small green pepper using an odd growth from an Alabama pine tree. I simply smoothed the rough outside, carved a large bug-eaten hole into the interior, shaped the seeds in the center, and added a recycled ivory caterpillar.

Since I've mentioned woods that aren't available commercially, I should mention curing green wood that

you collect. Simply cut or split it into thick planks (no more than 3 inches thick) and stack them in an out of the way place to dry, for as long as possible (but no less than one year). Put “stickers” (strips of waste wood) between the planks so air can circulate to all sides, and place them in an area out of direct sunlight, and with a reasonably stable temperature. Some woods will dry well with minimal checking or splitting, others will not. Try it, you have nothing to lose. You may also experiment drying a small piece in your microwave oven, on a low setting for several minutes at a time.

**CAUTION: Do not leave this activity unattended - wood may catch on fire if microwaved improperly.**

This is personal experience. While I didn't actually burn up the microwave, it did smell strongly of barbecued wood for quite a while.

## **Ivory**

Probably the most common material antique netsuke are carved from. Even contemporary carvers used ivory almost exclusively until the 1989 international treaties banning elephant ivory import and export. Today in the United States, marine ivory and elephant ivory cannot be imported or exported except under special circumstances. I would recommend against using these materials for anything other than your own personal enjoyment, and only then if you are sure they are from pre-1989 sources, or did not come from endangered species. Antique sources, the fossil ivories (mastodon, mammoth, or walrus) and hippopotamus teeth are about your only practical alternatives. Hippopotamus teeth are apparently considered a renewable resource, since zoos must continually trim hippo teeth in their captive animals. I've found elephant ivory in antique billiard balls, and the handles of antique toiletry items (mirrors and brushes) and antique curiosities (an ivory knife handle missing the blade). Even then, I would not attempt to sell elephant ivory, even if it is antique, since your local law enforcement agencies aren't likely to be able to tell the difference between legal (pre-1989) and illegal ivory. If you wish to carve netsuke out of antique ivory, just do so for your own pleasure.

## **Elephant Ivory and Fossil Mastodon or Mammoth Ivory**

These ivories carve well with both power tools and sturdy knives and chisels. Hand tool carving can better be termed “scraping” since ivory is much harder than wood, although I don't notice tremendous differences between the harder woods and ivory when using rotary carving tools. Elephant ivory is usually a translucent cream color, and yellows considerable with age. Ivory polishes quite well, and can, with special techniques, be colored moderately with stains. Ivory billiard balls are probably the most common sources of significant amounts of antique ivory, but may contain cracks and crazed surfaces from years of pounding, considering the nature of billiard and pool games. In cross section, tusks are similar to a tree. They have concentric rings and a central nerve channel. In portions of the tusk this central channel is sometimes closed (the Japanese carvers call this a “sleeping” channel). Other sections have a dark spot or opening. This may or may not be present in antique billiard balls. The fossil ivories have a somewhat “swampy” smell when carving, and are often attractively stained cream and brown from thousands of years lying in mineral-laden water and soil. Usually, fossil tusks have cracks along the length, as well as around the concentric rings, and carvable sections may be relatively small.





Fossil ivory cross section



Fossil ivory longitudinal section

The above cross section of fossil ivory show the crosshatched "Schreger" lines characteristic of the elephant, mastodon and mammoth ivories. The longitudinal section Schreger lines show up as long streaks.

### **Hippopotamus teeth**

This ivory is a uniformly stark white, and usually somewhat harder than elephant ivory. In addition, hippo ivory has layers of alternatively softer and harder material, leaving tiny ridges on the surface once polished. These ridges are only noticeable upon close inspection with proper lighting and are of similar shapes and size as the ridges of your fingerprints. Carves about like elephant ivory, with the exception of a thick outer layer of very hard enamel. This enamel will dull saws, rotary cutters and knives alike, but will take an attractive polish should you include portions in your design. When unwanted, I remove the enamel by soaking it in 50/50 water and muriatic acid (available at hardware and swimming pool supply stores). Remember to **ALWAYS ADD ACID TO WATER, NOT VICE VERSA**, and wear eye protection and rubber gloves! 30 minutes will generally remove the enamel, leaving a softened layer of ivory below. Remove the softened layer of ivory by scraping, or simply carve it away.

### **Bone**

I've haven't carved much bone, but it is somewhat like ivory, and slightly fibrous. It is cream to white in

color, with tiny black holes in it. All bone that I've seen has either a hollow or spongy center. Articles I've read recommend beef leg bone, boiled in water with an onion (?), dried and bleached in the sun for several weeks. Give it a try. If you can't obtain some ivory, it would be an acceptable substitute for barnacles in marine subjects.

### Antler and Horn

Often (and incorrectly) people use these two terms interchangeably. Antler consists of bone, usually shed each year and regrown the next. Horn, on the other hand, is a permanent fixture on the animal, and while it may have a bone core (like cow horns), is actually built from the same material as your fingernails. Some "horn" isn't horn at all, such as rhinoceros horn, which is actually hairs cemented together.

### Antler

Some of my favorite antique netsuke are carved from deer (red stag) antler. Antler is definitely a challenge to carve because of its restricted size and configuration. Wood generally comes in blocks, but antler only comes in funny shaped sections, creating a requirement for very restricted compositions. That said, this very restrictiveness can be very interesting and lots of fun. The outer surface of fresh antler is invariably medium to dark brown, with many small knobs and ridges. Antlers that have spent a lot of time out of doors are white to grey from exposure to the sun. Inside is a layer of white-to-grey bone, surrounding a spongy center of varying porosity. Stag antler (from an Asian red deer) and moose are the best I've found, with the least spongy center, and the thickest bone layer. Other deer species seem to have more spongy center. The thick bony layer of antler carves well, about like ivory, but the spongy center requires care. Rotary cutters and knives seem to catch on it and dig in. In all species that I've looked at, the bony layer is thicker with a less spongy center near the crest, where the antler attaches to the skull, and also further out towards the tips. Fortunately, antler is shed every year, so using this material doesn't necessarily require the death of the animal. The following images are of antlers of several different species of deer.

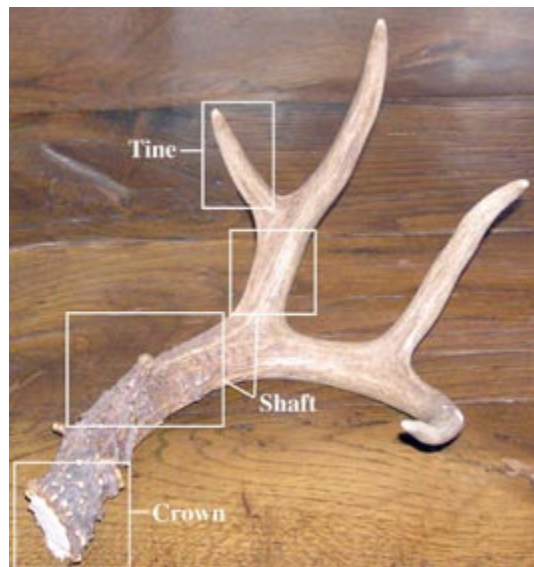

Above is a typical large whitetail deer antler, about 14 inches from base to tip. I've labeled the areas we'll

be discussing with the section names I'm going to use.



The above images are cutoffs of the crowns of whitetail antlers, very common in the United States. The first three are of shed antlers. Deer generally shed their antlers each year after mating season, and grow a fresh set the following spring, adding tines (the pointy parts) each year. This leaves a rounded portion at the base of each antler. These portions are usually the most solid with the least amounts of spongy center. The wavy base is also quite nice to carve and has a really neat appearance. Since shed antlers simply fall off the deer and are left lying on the ground, they come in many different states of preservation. Left alone in the sun, they become white and will actually rot away. The antlers are a good source of minerals for the little critters of the woods, and the antlers are often gnawed, as in the second image above. The last image above shows an antler crown from a deer which was killed by hunting, and has a section of skull attached. This bone can be carved just like the crown, and is usually quite solid. While I have occasionally carved antlers from hunted deer, I much prefer to obtain shed ones. While I'm in favor of humanely harvesting non-endangered animals, I feel a little sorry for wild creatures and the gradual reduction of their

environment today.



The three above images are of a section of the main shaft of an elk antler. Notice the thin outer (and carvable) areas and the large spongy center. The center spongy material is usable only for broadly carved elements, as it is far too fragile for small details. This is the cause of antler's difficulties. Large sections aren't normally available, so compositions are severely restricted by the narrow sections.



The above image is of a deer antler tip. Tips are generally (but not always!) more solid than the shafts, and will hold detail well, but are much narrower and will restrict composition.



The above image has various cross sections of antler shafts, as well as a section of fossil ivory for contrast. Notice the various colors of the antler and the varying color and density of the center spongy sections.

Notice the top second from the left section of a piece of red stag antler (my last piece I've been jealously husbanding for just the right project). It is quite light in color, with very thick walls and little spongy center, carves very well and is quite expensive and difficult to obtain.



Above are cross sections of moose antler. The right-hand section is through the shaft near the crown (next to the skull) and the left section is through the large flat "palm" section. The shaft is quite dense, with very little spongy center and carves very well, almost identically to ivory. Since this is a shed antler from Alaska and may have spent several seasons out of doors, the shaft has several radial cracks which would have to be taken into account during carving. The palm sections have fairly thick, hard outer sections, but have much more spongy centers than the shafts or the tines growing from the palms.

## Horn

Most horn readily available to us comes from cows. Cow horn is available in lots of colors, from black to brown to white and is usually hollow, except at the tips. Below is an example of cow horn, in a common color and translucency. The horn is quite thin at the base, and gets thicker the closer it gets to the tip. At the lower right is a tip cross section of a translucent black horn. Horn carves well, especially with power tools, but can be rubbery and fibrous (notice the fibers on the outer layers) and difficult to carve with hand tools or polish. Polishing should be done slowly, not allowing excessive heat build up, which can scorch the surface. Light colored horn can also be dyed, although there won't be a dense build up of color, nor will the color penetrate deeply without long soaking.

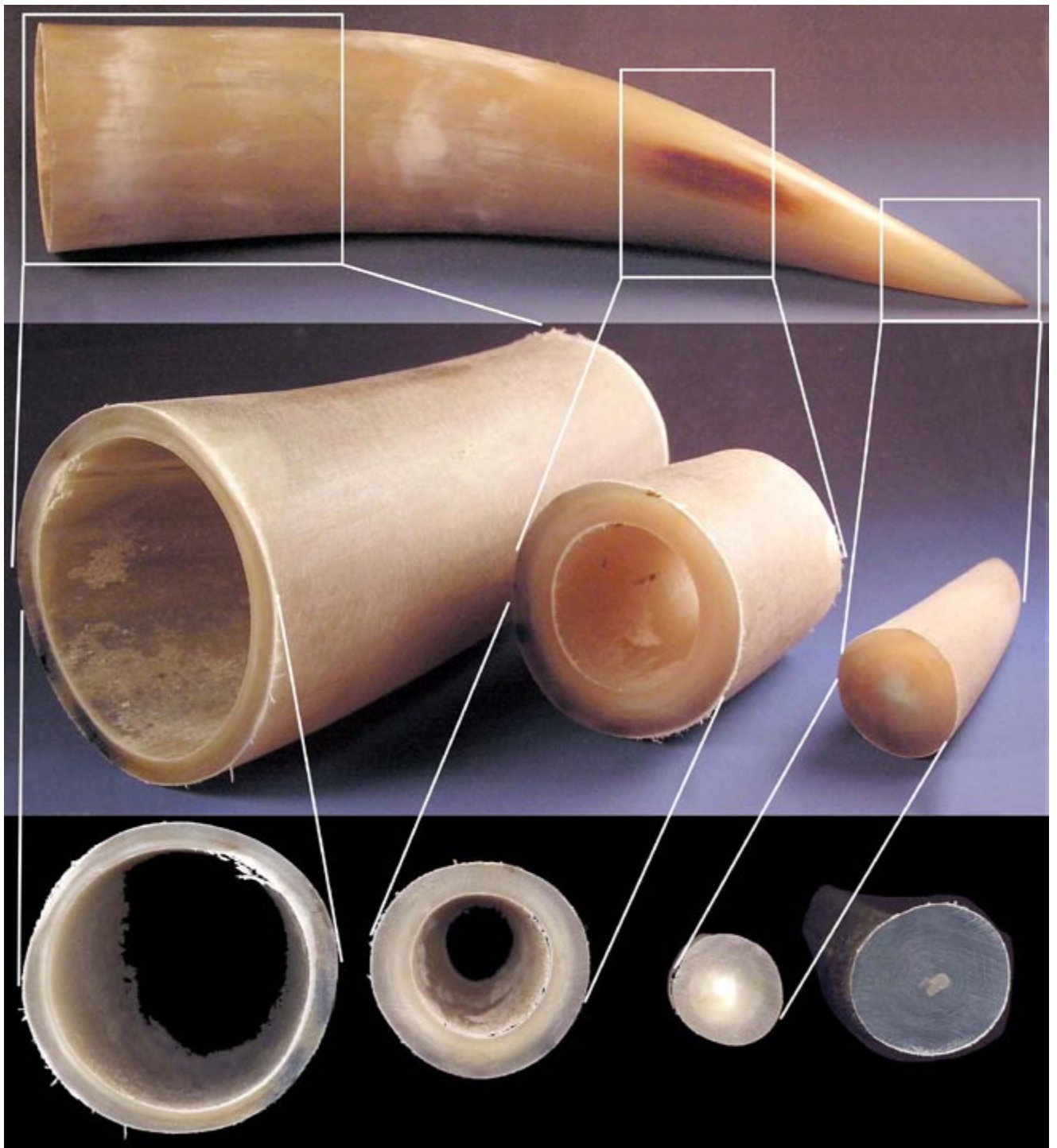

## *Ideas, Subjects, Research and Design*

### **Ideas and Subjects**

I've found that by far the hardest part of carving is coming up with a good subject to carve. Artists often say that the most difficult thing to face is a blank canvas. I find that true of a block of wood as well. Sometimes a piece will suggest an idea simply from its shape or color. Then it's easy. Other times I have to search for an idea that appeals to me. If you become a student of antique netsuke, you'll quickly notice many netsuke of almost identical design and subject, even from carvers widely separated by school and locale. Some of this can be accounted for by the popularity of particular themes, but I suspect a good portion can be attributed to the age old difficulty of coming up with a good original design. If your livelihood is carving netsuke, you must continue to carve even when you are experiencing a mental block. Fortunately for most of us, carving netsuke and finding marketable ideas is not our immediate problem. For the novice netsuke carver, I suggest carving a few of the designs presented in this book or one of the many reference books on netsuke before striking out on your own untrodden path. I started by finding a design I would like to own, searching for it amongst the netsuke dealers in London, and not finding one, I carved my own. I constantly look for ideas among carvings, sculpture, paintings, art publications, nature books and magazines, TV shows on PBS, anything, anywhere. You never know when an idea will strike. When I get an idea, I immediately write it down, because it may be some time before I get the chance to carve it. I have a midget memory, so I'm certain to forget it before I can get around to carving one. Try keeping pencil and paper at your bedside; I find many of my ideas come just before sleep. When I'm waiting for the doctor, dentist or government bureaucrat, I peruse the fishing, hunting, National Geographic magazines, etc. If you make a trip to the library or book store, look through the art, nature, and magazine sections. Don't overlook the children's sections, either. I've noticed many kid's books seem to have excellent nature photographs and illustrations, and I've found about a third of my ideas from them. If the subject is cute enough to appeal to children, it will certainly appeal to woodcarvers! (I wonder what this really says about us?) Make a folder of interesting photos and ideas for research once you've chosen a subject.

### **Research**

Once you have a carvable idea, the rest is downhill. Libraries and bookstores provide the bulk of my research materials, but don't overlook trips to zoos, art and natural history museums, nature reserves, etc., with camera in hand. To illustrate the point, my local zoo news publication had an article about Komodo Dragons hatching in their reptile nursery. It seemed to me a baby Komodo Dragon hatching from an egg would provide an excellent subject for a netsuke. The article even had a fairly good picture with it. Unfortunately, pictures are 2 dimensional, and not necessarily life sized. Once you begin thinking about how to carve a particular subject, lots of questions will present themselves. How big is a baby Komodo Dragon at hatching? Can I carve it life sized, or will I have to carve it reduced or enlarged? How big and what shape is its egg? Is it football shaped, or larger on one end like a chicken's egg? Is the eggshell hard or rubbery like a snake's egg? (Incidentally, a Komodo Dragon egg is between 2.5 and 4 inches long, has a rubbery membrane, and is football shaped.) How many toes are on a Komodo Dragon's feet? Are they all the same length? Claws? What shape and pattern are their scales? What does one look like from the top? The side? The bottom? A single picture only shows one view, and your netsuke will be 3 dimensional. Not only that, but your admirers are going to examine every millimeter of your carving, front, back, top, bottom, sides,



and inside out! Suffice it to say, a single picture generally isn't enough. On top of that, as appealing as the subject was to me, information was simply not available on baby Komodo Dragons. Every reptile book had a picture of a 10 foot long Komodo Dragon, but none had a picture of a young one. Finally, I found a specialist herpetology magazine that looked promising. It had the same picture I already had, but did say how long the eggs were. It did not say how wide they were, or a ratio of length to width, I'll just have to estimate that from the picture. Fortunately, the zoo had a 6 month old baby Komodo Dragon on display, so I solved most of my problems with a camera. All of that took about six weeks, between coming up with the idea and enough information to begin working on the design.

## Design

Remember the general principles of netsuke design - netsuke are compact, with no sharp or delicate protruding parts, are generally small and feel comfortable in your hand. Of course, don't think you have to obey all of these rules, since your netsuke isn't likely to be worn on your kimono all day, everyday. Break the rules if you want; the netsuke police aren't going to arrest you. Also, always remember that above all else, netsuke are a form of art. A perfect copy of a picture or subject isn't necessarily good art. I've seen many sculptures that were faithful copies of a subject, and which missed the mark completely. Don't be afraid to reposition your subject, add or subtract parts which aren't in your reference pictures to achieve pleasing composition. We really don't want to spend our lives making copies, anyway. While copying is often how beginners learn, our eventual goal is to produce original interpretations. Good art is a personal interpretation; an abstraction of how things should be or should appear, not necessarily how they appear in real life. If it's an exact copy you want, you should probably take up photography as a hobby, and not netsuke carving.

I develop most of my designs on paper, and in my head. Many successful woodcarvers work from clay models when developing their designs. While wood is a subtractive medium, clay is an additive one, and is much more forgiving of mistakes. If you remove too much clay, you can put it back. Wood isn't as easy. If you feel more comfortable working out your design in clay, then by all means do so. Usually, for complex subjects I work up a two-view (front and most detailed side) drawing on my computer, using a paint and drawing program. I will print out several versions; one that is enlarged to show detail clearly, and several netsuke-sized versions. One will be for reference during carving, and the others I will glue to the raw wood for cutting out and rough out. If you draw up your designs by hand, don't forget that most copy machines can enlarge and reduce, so for little money and effort you can have all the reference and sacrificial drawings of the right scale you want.

## How long do carvings take?

That's a hard question to answer. Often, I jump around during the process of carving because I'm curious about how a certain texture, inlay, or technique will look, rather than following my own advice about approaching a subject with a sensible and sequential plan. That's just the strange way I work. By now, you probably believe I think in strange ways, too. You're probably right. At my first large woodcarving show and competition, a lady psychologist accused me of having a lot of womb symbolism in my work. Maybe she was right? You'll probably develop your own peculiar ways, as well. I find I spend an average (estimated) of about 30 to 50 hours per carving. Some take less, some take more. I estimate the alligator

hatching from the egg took about 60 hours. I say estimate, because often I'm experimenting with different techniques, rather than carving merrily along. For example, I had to develop techniques to produce the scales on the baby alligator, and smooth such a large expanse of boxwood as the egg's surface. On an ebony bumblebee and blackberry (about 20 carving hours, several other hours for research), I had to develop a method of making the thorns on the blackberry stem look convincing, yet not be so delicate as to be untouchable. I also had to develop methods for inlaying light colored wood for the bumblebee's stripes. I also think I'm getting faster as I gain experience. I don't seem to have to re-invent the wheel as often. Hopefully this book will help you learn faster than I did. Or maybe I'm just particularly slow or hard headed about learning things?

### General techniques of power carving

Just as painters are taught to use the largest brush they can, power carvers should generally use the largest bit they can get by with. More often than not, the job will go quicker, and yield better looking results. Always attempt to get the surface as close to the finished texture as possible. This will reduce the time and effort spent in the finishing process, and provide a better finish in the long run. On carvings of as small a scale as netsuke, even the finest sand paper can often leave scratches that look like the Grand Canyon!

**Hint: Always let the power tool do the work. If the motor slows down or stalls during carving, you are asking the cutter to cut too much, too fast. Take smaller cuts with lighter strokes.**

### Work Holding

I almost never use a vise, although I sometimes find it useful to steady the work against the workbench or a backing. Sometimes I mount a 4x4 in my workbench vise to raise the carving up closer to eye level, and press the work piece against the top or sides. You may find it useful to fasten a 3/4 inch thick board with a "bird's mouth" to the top. This is my version of the traditional Japanese netsuke "workbench." Of course, the Japanese version is used while seated on the floor. For the sake of my back, I sit at a regular workbench, with the bird's mouth held in the vise, and about chest high. Be careful when pressing the work against something hard, however. You certainly don't want to break off pieces of your carving. You may also find it useful to use a bench hook. I have two basic methods of holding the work piece and the rotary tools by hand; one for general carving and the other for fine detailing. The first method is with the heavy duty or general purpose hand pieces.

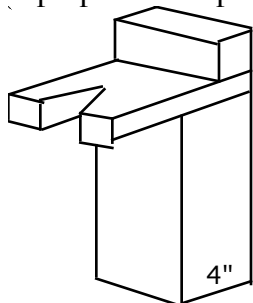

Bird's Mouth

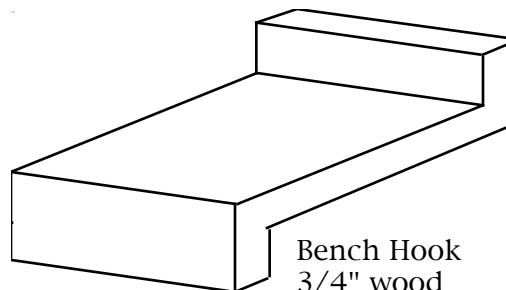

Bench Hook  
3/4" wood

I hold the carving in my left hand, and the rotary hand piece in my right hand like you would hold a hammer in your fist. This provides the best control for heavy cutting in the roughing out stages, when I'm usually using large, fast cutting burrs. This is the stage when the cutters are most likely to grab and "run." In the final stages of rough out, a "run" might be disastrous.



**The "Hammer Grip"**

The second way is most often used for detail carving with the thin rotary hand piece. Again I hold the carving in my left hand, but I hold the rotary hand piece in my right hand as I would hold a pencil. By the way, I'm right handed, so if you are left handed, I don't know how you would handle this. The cutters rotate clockwise (when viewed directly on the cutting end). This will cause the forces created by the revolving cutter to drive the hand piece towards you, not away as in a right handed person.



**The "Pencil Grip"**

There are reversible rotary carving tools available, but the reverse rotation can only be used with abrasive cutters like the diamond bits or ruby carvers. Any cutter with blades will be rotating the wrong way, and will only burn the work, not cut it. All carving motion comes from the hand, and not the arm. For the "hammer grip" I often rest the thumb of my right hand against the work or the heel of my left hand, and use my right fingers to pull the hand piece towards me in short carving strokes. This resists the tendency of the revolving cutter to pull away from me, and offers the greatest control, either for power strokes, or delicate carving.

For use with the “pencil grip,” I usually rest both hands or wrists on the workbench or work holder surface (bench hook or bird’s mouth). Sometimes, I simply bring both arms tightly against my chest, and hold the work suspended in mid-air, not touching the workbench. This tends to bring the work close to your face for best viewing; however, it is also very close to your eyes. Be sure to wear eye protection. Cutting motion comes from my thumb and first two fingers, usually short strokes towards my body. Usually, my little finger and right ring finger are pressed against the fingers of my left hand to steady the carving tool. Extra care is required when a sharp corner is near the rotary cutter. If the corner is behind the cutter, there is a danger that the rotary motion will grab the corner, causing a “run.” Think of the rotating cutter as the wheels of your car. When turning, it wants to cause the “car” to move forward. You are resisting that motion with your hand, but if the “wheel” suddenly gains excessive traction (the sharp corner), it will move quickly and unexpectedly. If you are paying attention, you will be ready for this tendency, and successfully counter it. If it’s a surprise, your work may be damaged. You can practice this by carving a small cube of wood, and observing what the rotary carving tool wants to do when carving on the face, and on the corners. If you are going to carve delicate structures near a corner, it is best to approach that corner from behind, that is, with the corner between the rotary cutter and your body (this procedure is for right handers; left handers, work this out yourselves). While grain direction is less of a concern for rotary carving than hand carving, it does play a role. If the corner is such that it must be approached against the grain, then you have two choices. Carve against the grain if your wood type will allow it (tight grained woods usually don’t care much), or if you must carve with the grain to avoid fibers chipping out then use the smallest diameter cutter you can, or switch to an abrasive cutter. Smaller diameter cutters and abrasive cutters (diamond cutters or ruby carvers) generate less force and are less likely to run. Be aware of what the tool will do, and be alert to resist it.

### **Texture and Shadow**

I seldom use stains or chemical darkening, and have never used paints on my netsuke. To gain definition, I either use a different colored or valued (darkness and lightness) material, or different textures. I have six basic textures that I tend to use. They are (in order of frequency of use):

**Dimples (holes)**

**Small Raised dimples**

**Punch textures**

**Wire brush**

**Short knife cuts**

**Hair and Fiber**

**Oblong cuts**

An artist’s trick to reducing textures and tones to their most basic value is viewing the model or research materials through tightly squinted eyes. This tends to reduce the detail, and points out the basics. Give it a try when attempting to simulate texture.



### **Dimple Texture**

Dimples are the simplest type of texture using a rotary carving tool. The example shown is dimple texture surrounding the “A” in a small necklace of Mayan bloodwood and Osage orange I made for my daughter. The dimples were made using a very small ball cutter. They are simply holes poked into the surface using ball cutters.

Typically, my dimples are as deep as half to three quarters of the cutter diameter. They are closely spaced, with some of the holes overlapping, but most with a tiny ridge separating them. I don’t put them in with much care. I think the most successful textures should look random. I just poke in the holes quickly, taking care to cover the surface well. Sometimes, I outline the area to be textured with dimples first, being careful not to destroy the surrounding detail. You must be careful, however, not to make it look like an outline. Don’t place the dimples in too neat a row. After most of the dimples are in, I look them over and go back to areas that need more dimples, or look too regular. Often, I use several sizes of ball cutters, starting with the larger ones and working to the smallest.

For netsuke carving, the largest is about 1/8 inch in diameter. The larger the dimple, the shallower the hole is, and the smaller dimples actually go inside the larger ones. I don’t want the larger dimples to be discernible from the smaller.

### **Small Raised Dimples (Lizard Scales)**

Here’s how to construct a very useful tool for making small raised dimples. Begin by cutting a small piece of metal rod, of a diameter that will fit in your selection of collets or hand pieces. Chuck it into your hand piece and spin it up to at least 10,000 RPM. Using a tiny abrasive cone or bullet-shaped burr held in your

hand (and dipped periodically in water to keep everything cool), cut as small a hole in the end as you can, to a depth of about 1/32" (see picture step 1 below). Then, using a larger abrasive (preferably diamond) ball-shaped burr held in your hand, wear down the edges of the rod until they intersect the cone-shaped hole (see picture step 2). Once these edges are sharp, they will cut nice, neat round dimples when used in your grinder. Don't run your grinder too fast, however, or you'll burn the dimples. If you're making lots of dimples, you'll occasionally need to clean out the hole in the end of the tool. Be sure to practice on some scrap wood first!



### **Dimple Tool Construction**

Incidentally, I've successfully used both 3/32" steel rod and brass (bronze?) brazing rod. The steel lasts longer, but the brazing rod is quicker and easier to manufacture. I usually put a dimple cutter in both ends of the rod, each a different size. On my Komodo Dragon I used scales of two different sizes, mixed in together in the patterns of the brown and yellow skin colors.



### **Punch textures**

I most often use my Foredom™ reciprocating hammer hand piece to produce punch textures. This produces small indentations on the surface, as closely spaced as necessary to achieve the effect you desire. An example of punch texture can be seen on the wasp in the gourd netsuke in the **Pattern Pages** of this book. If you look closely at the edge surfaces where the wasp has eaten the gourd, you can see the punch texture. Once the texture is placed in all the areas needed, I follow up with the polyester abrasive pads to smooth any rough areas. My hammer hand piece has a small tip that tapers to a quick, shallow point, at an included angle of about 60 degrees. I suspect a point with a shallower taper would stick too deeply into wood surfaces, and the hammer hand piece would not function correctly. Also, a thin point wouldn't leave a large enough hole without going excessively deep, perhaps splitting the wood and damaging the carving. Incidentally, my hammer hand piece can adjust how hard the point is driven in. I play with this setting on a scrap piece to determine the best force for the material I'm working on. Large sewing needles (reground into a steeper point) in a handle also work, although slowly. Many carvers solder several nails together (properly sharpened beforehand, of course), and tap them into the wood for faster texture production. Rotate them as you go for a more random appearance. For the smaller areas typically found on netsuke, try soldering 5 or 6 large sewing needles together, reground with shallow points



**Detail from Robber on Log (see Inspiration chapter).  
The artist darkened the cuts with ink.**

### Short knife cuts

Often, short, sharp cuts are useful for simulating rough textures, like bark, rock surface or tiny scales. In general, use this texture for surface features which might be too small to put in individually. They can be made by any number of tools, like the point of a fairly thick-bladed knife or engraver. I like the diamond sectioned engravers the best. Thick blades are a must, because the cuts are produced by stabbing the point into the material, then levering out the tiny chip. Often, the tiny holes produced are triangular in shape. Space them as closely as you need to. This texture is most useful on materials with very tight grain, and little or no grain patterns. They may also be less effective on dark woods. The surface may be left somewhat rough and splintery after knife-cut texture, so be sure to smooth the textured areas with the polyester abrasive pads, or a wire brush.



**Multiple textures used in the crab and bucket (see Projects chapter),  
hair and fiber for rope and wood slats;  
shallow dimples for hammered metal bands.**



## Hair and Fiber Textures

I simulate hair and fiber textures with many small parallel lines. These can be applied with knives, sharp pointed engravers, file edges (as in the crab and bucket wood slats and rope detail), or with rotary cutters. Rotary cutters might be coarse abrasive stones, structured carbide bits, or just sharp-edged or pointed cutters. Whatever you think will do the job. This is another area for experimentation. Many variables determine how the texture will look: depth of lines, spacing, width of cuts, how they are started and stopped, the pattern they are applied in, etc. Practice on scrap material to determine the best type for the carving at hand.

## Wire brush Texture

The little circular wire brushes for rotary carving tools are very versatile. They can be used to clean the “fuzz” from your carving or, used more vigorously, can impart a texture of their own. When used with the grain, they typically will dig out the softer areas (the summer wood portion of rings), and leave the harder. Used across the grain, they leave little scratches, and dig out the rings less. The brushes also vary in stiffness, with the stiffer ones leaving more obvious texture. One drawback to the wire brush is its inability to get into every little nook and cranny. They are most useful for broad areas of texture, and cleaning out long undercuts.

## Oblong cuts

Oblong cuts are essentially long dimples. They seem to be most useful for simulating smooth body texture (like snails) when directionality is desired. The oblong dimples should flow smoothly along the length of the body surface. Don't forget that you can use different sizes of ball cutters, just like the round dimple textures.

## Combined Texture Techniques

I often use the preceding texture techniques in combination. An example is the reciprocating hammer-punch texture followed by a wire brush to simulate pottery. I used this technique to simulate pottery in the *Octopus on Broken Pot* netsuke in the **Projects chapter**. Another way might be to texture with one of the previous methods, then carve or polish away parts of it. Use your imagination, innovate, experiment, and maybe just get lucky.

## Shadow

Carvings often need shadow to delineate details if there are no other dividing elements like color, value (tone), or textural contrasts. One way you can achieve shadow is by undercutting details like arms, masses of hair, etc. I often use a thin, hairline engraver or a hook scraper to create a tiny undercut line along the edge of details, even those with a significant undercut. For instance, an arm held tightly against the body in a figural netsuke would need a tiny undercut separation line, even though it is carved in the round and already significantly undercut. This makes a tiny dark line that separates the elements of the composition, and is visible from every angle. Picture a carving of two cubes, one smaller than the other and sitting on top of the larger. If the sides of the two cubes are carved to the meeting points with no undercutting, the composition will look right only from certain angles; when the meeting points are in deep shadow.

Tilt the carving slightly so the lighting changes, and the contrast between the smooth side planes of the

cubes vanishes, along with the viewer's conviction that they are actually two separate cubes. Netsuke are constantly picked up and viewed from every angle, so you cannot depend on the shadows being right. The two cubes would only make a successful carving if you provide the tiny undercut along the meeting points so a dark line is always present, in any light, and at any viewing angle.

### *Making and Inlaying Small Wood Eyes*

I have this ingrown aversion to seeing inappropriate additions to wood carvings. Things like store-bought glass eyes or even worse, beads or such things meant to represent eyes. I like to think of a carving as something I create by myself, not something created in partnership with someone else. How about taking a little more effort to dress up your hard work by inlaying eyes you make from colored woods?

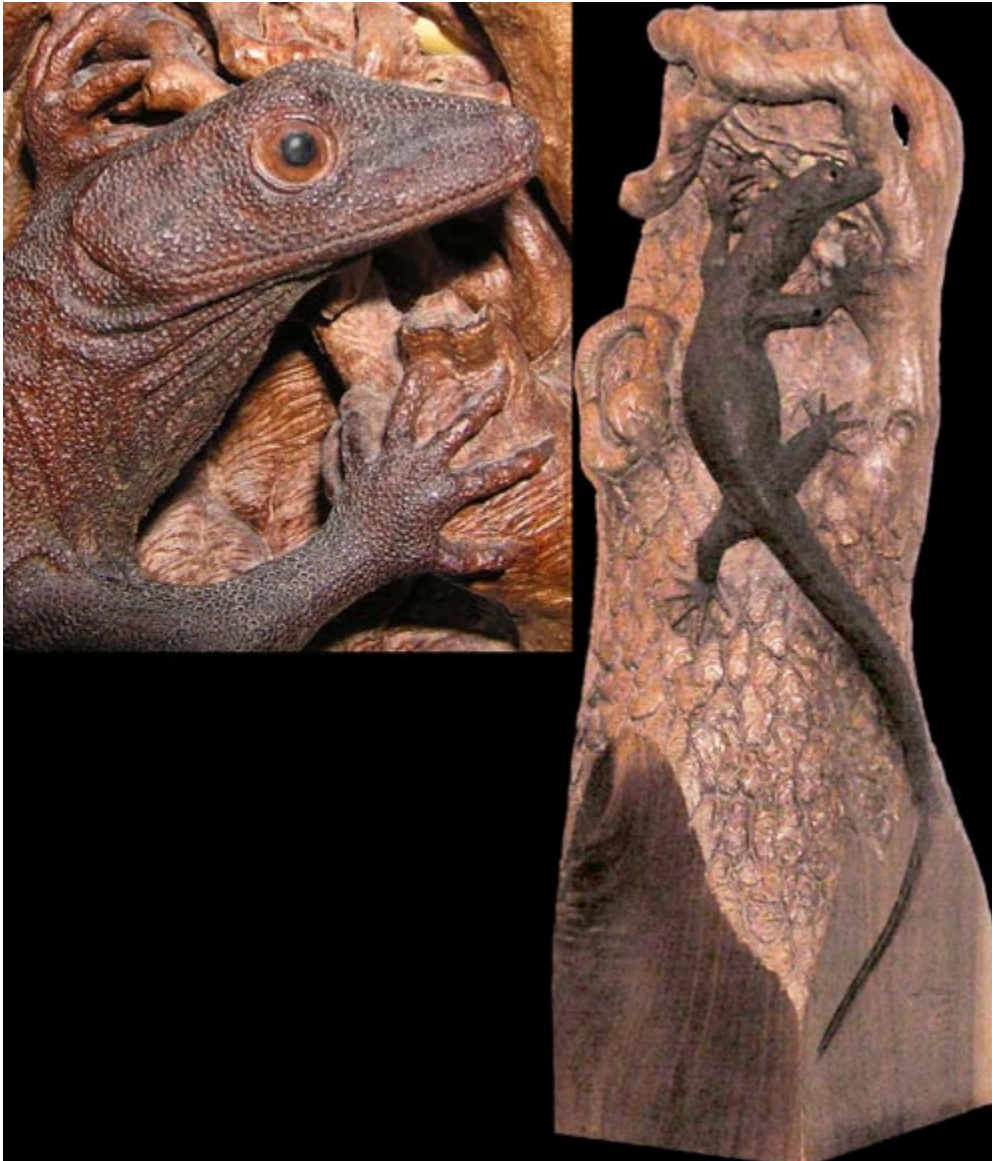



I've found inlaying colored eyes in my smaller carvings seems to enhance them immeasurably. Since I never paint and seldom stain my work, many times I'll use several colors of wood to add realistic and contrasting eyes. Most artists will tell you that eyes make the piece, and I believe that too.

I've taken my cue from antique Japanese netsuke, the archaic art form of Japan that thrived during the 1700s and 1800s. These tiny but spectacularly intricate works of art were carved from almost any imaginable material, but ivory and wood were the most common. Many of the most beautiful had eyes inlaid in contrasting materials, and it's these types of eyes I want to talk about.

I make my eyes from various colors of hardwoods, horn, amber or fossil ivory, trying to come close to the real eyes of my carved subjects. I try to match their colors with a colored material, and using these techniques, I've inlaid eyes ranging from a millimeter in diameter, up to half an inch (so far, that is). Some common hardwoods I use are holly (white), ebony (black, especially good for pupils and rodent eyes), lemonwood (yellow), ironwood (dark brown), and Mayan bloodwood (red). Any close-grained wood will do, so your color palette really is limited only by your imagination, with the possible exception of green. I haven't found a suitable green-colored wood I like, yet.



Now, let's have a short survey of eyes in the natural world. Humans have eyes of three colors: the white of the outer eye, an iris color (usually brown, blue, or green), and a black pupil. Mammals like cats have two colors that show, with the added problem of elongated, non-round pupils. Dogs usually have eyes of only two colors, white (usually little can be seen), and a dark iris center. Other than the few breeds of dogs with blue eyes, pupils are usually not easily seen. Smaller mammals and rodents like mice have single colored eyes; all dark, unless they're human-bred white lab rats and mice with pink eyes. Birds often have two-color eyes, with a wider range of iris colors like yellows and bright greens. Fish generally have large eyes, generally of only two visible colors: an iris and a pupil. They also usually have nice large round pupils.

The easiest eyes to make are those with only round parts. They are easily made with a lathe. You don't have a lathe? Well, read on and I'll tell you how to deal with that problem. Eyes with elongated components are a little more difficult, for creatures like cats, dragons, many types of snakes and lizards, goats, octopus, etc. Inlaid eyes can be complex or simple. I usually make eyes consisting of two parts only, the "whites" of the eye, and the iris. In the small carvings I generally make, anything more won't show, and is simply courting disaster. Many times, especially when my carving is in a light wood, I'll only inlay a single dark iris or pupil. This all depends on how large your carving is and what effects you're seeking. Generally, the larger the carving, the more complex the inlays must be.

Well, enough waxing poetic for now. Here's how I make the eyes. For the sake of argument, we'll start off making a small human eye. I generally carve my inlaid eyes in place on the carving itself. I begin making the inlays after the carving I'm working on has the face mostly finished, carved down almost to the actual surface of the eyes. I take out my assortment of power carving ball-shaped burrs and choose one that has the same diameter as the largest portion of the inlay I'm going to make.

## Round Eye Inlay:

### Step 1 - Determine burr size for inlay

I decide by holding each ball-shaped burr up to the eyes of my carving to see which will match the best. I use calipers to measure the diameter of the burr. That's the size of the peg I'll turn on my lathe for each eye. I turn the peg of an appropriately colored, tight-grained hardwood, using my calipers to determine the right diameter. In this example, we'll use holly for the white of the eye. I turn each peg with a very slight taper. This taper will insure a tight fit at the surface of each eye, making an invisible joint.

### Step 2 - Turn tapered pegs of colored hardwood (tapers exaggerated for clarity)

Using your smallest round ball burr, drill a pilot hole in the center of the eye. For small holes, don't use a drill bit! You'll find small, thin drill bits will tend to wander badly, following the grain and ending up out of center, and out of round. You've already put in a lot of work on your carving so far. Don't trash it now! Using successively, ever-larger ball burrs, drill out the hole until you reach the size of your chosen and measured burr. As I approach the desired hole size, I keep test fitting the turned peg. Remember that each burr you use will drill the hole out to a slightly larger size than its measured diameter, and if you aren't very steady at hand, the hole won't necessarily be perfectly round. This continual test fitting will allow you to make slight corrections if needed. Once the hole and peg fit correctly, I'll glue the peg in, with a fair amount still left above the surface. If I'm in a hurry (and I often seem to be!), I'll use instant cyanoacrylate ("super") glue, but realize I should be using epoxy, or white or carpenter's glue (as long as the carving won't be exposed to moisture or extreme temperature changes). Then I'll carve the peg and the eye down almost to where it needs to be. With the white of the eye cut down flush with the surface, I'll repeat the above tricks for each successive inlay of iris and/or pupil. When I'm happy with the results, I apply a semi-gloss finish if I want a shiny look, otherwise I'll apply whatever finish the piece will receive.

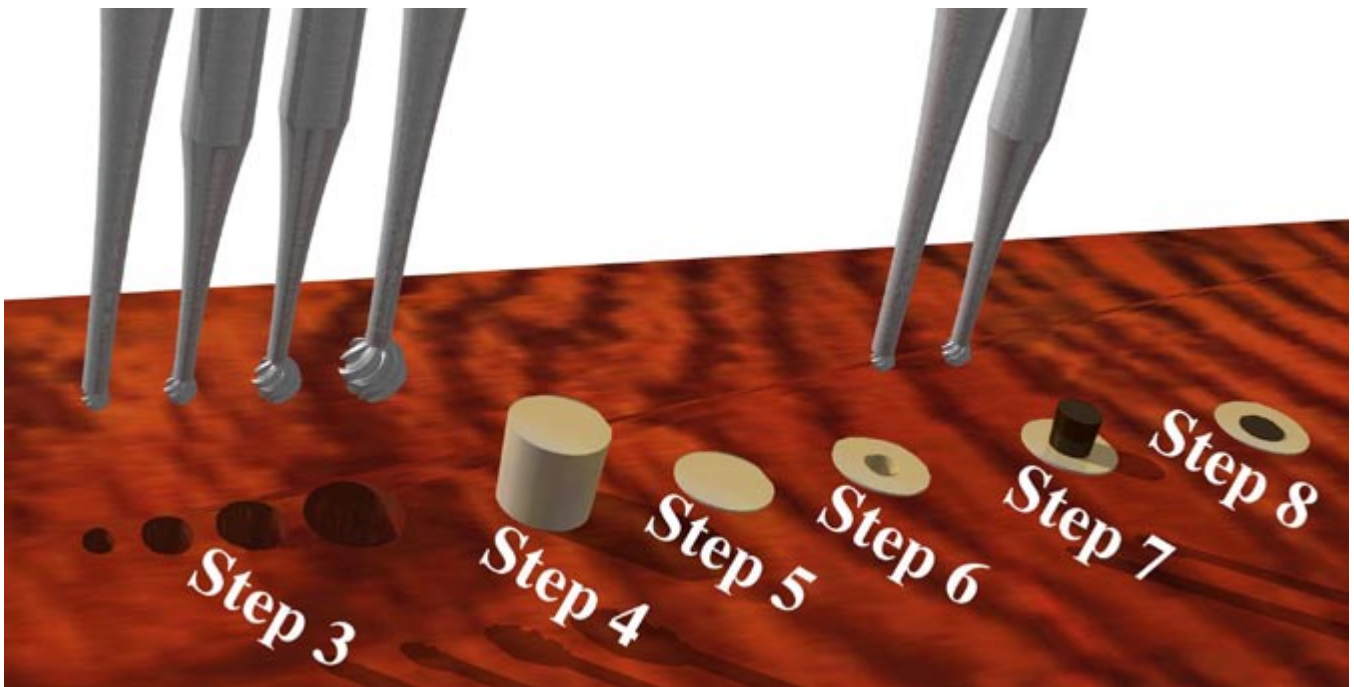

**Step 3 - Drill a small hole, then successively enlarge the hole stepwise with increasingly larger burrs**

**Step 4 - Glue in tapered peg, so that some is left above surface**

**Step 5 - Carve peg almost down to eye surface**

**Step 6 - Drill successive sized holes for pupil or iris**

**Step 7 - Glue in tapered peg**

**Step 8 - Carve pupil or iris peg down to eye surface**

**Step 9 - Apply finish and admire your work; you're done**

For most smaller carvings, we could get away with round eyes, but not for larger sized eyes. If you want to inlay larger sizes, you'll run into anatomy problems. If you look at eyes closely, you'll find many aren't round. Think of the proverbial almond-eyed beauty of literary mention. Don't worry though. If you turn your pegs slightly larger than the largest dimension of the eyes, you'll have a little room to work with. Drill out the eye holes as before, but when you get near the eye size, you'll have to begin carving the holes to the desired shape. You can then carefully shape the peg to fit. Be sure and test fit the peg as you go along, trimming the sides to get a close fit. If you carve the inlays with a slight taper, just as we turned them on the lathe, you should be able to achieve tight fits with a little practice. If you're lucky, your iris or pupil will still be round, and you can drill and turn those parts as before.

If it's a reptile or cat eye you want, you can drill, glue, and inlay the main portion of the eye as before, depending on the final size. Leave the eyeball rounded and standing proud of the surface of the face. You can inlay slit pupils by taking a drum-shaped burr (with a 90 degree profile) and carefully cutting through the raised portion of the rounded-over eyeball. Be sure to orient this cut in the proper direction of the slit

pupil! Rather than using a round peg, here you'll use a small square peg (with 90 degree corners), glued on its side into the slit. When dry, carve the square peg down to the surface of the eye and you'll have a slit pupil!

### Cat or Reptile Eye Inlay Steps:

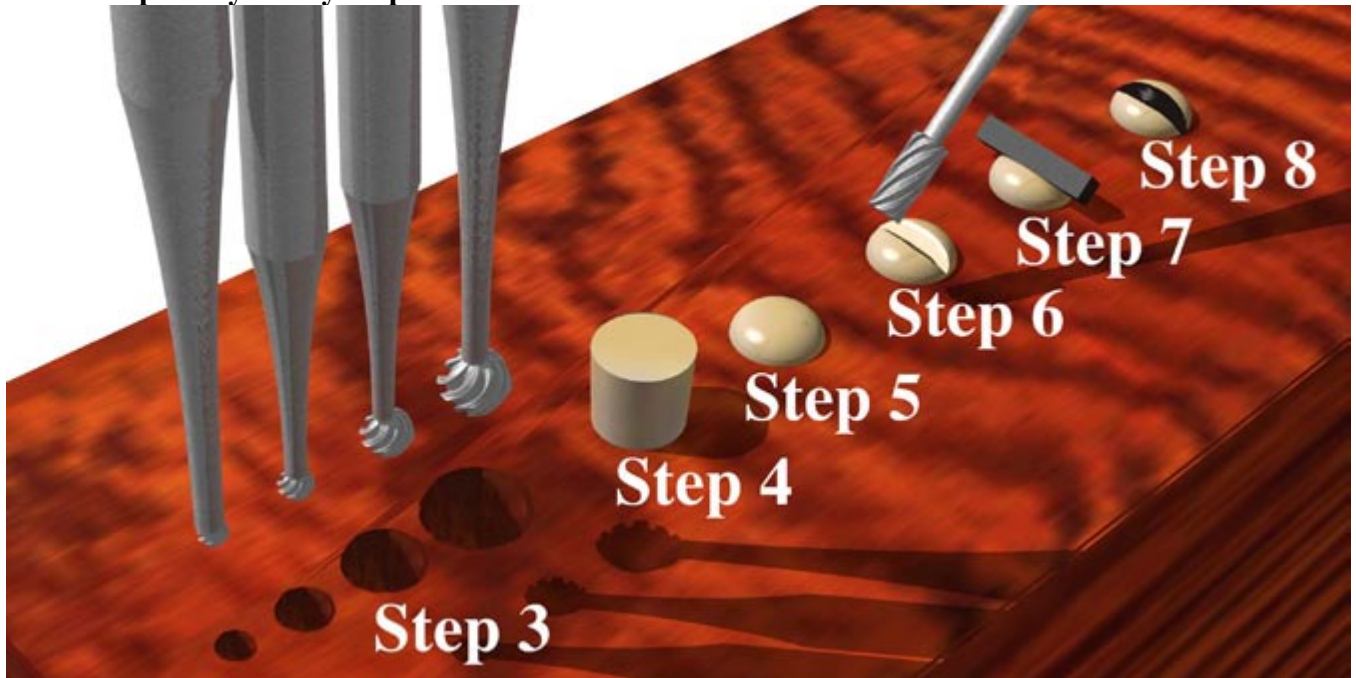

**Step 3 - Drill successive sized holes**

**Step 4 - Glue in tapered peg**

**Step 5 - Carve peg, leaving rounded surface above face**

**Step 6 - Cut groove using cylindrical burr**

**Step 7 - Glue in 90 degree square peg**

**Step 8 - Carve pupil peg down to eye surface**

**Step 9 - Apply finish and admire your work; you're done**

I use a Sherline miniature metal cutting lathe for most of my eye peg turning work. The Sherline is an excellent piece of miniature precision metalworking equipment. It seems tailor-made for this kind of operation. For those of you who ever have a chance to do some wood turning on a metal cutting lathe, give it a try. It's easy, and the results can be nothing short of awesome. Unlike its larger brethren, the Sherline has a headstock that can be turned out of its alignment axis in order to cut slight tapers. If you don't have a Sherline or other kind of lathe, you can make a small lathe using a flexible shaft carving machine (like a Foredom™).

## Homemade Lathe using flexible shaft carving machine

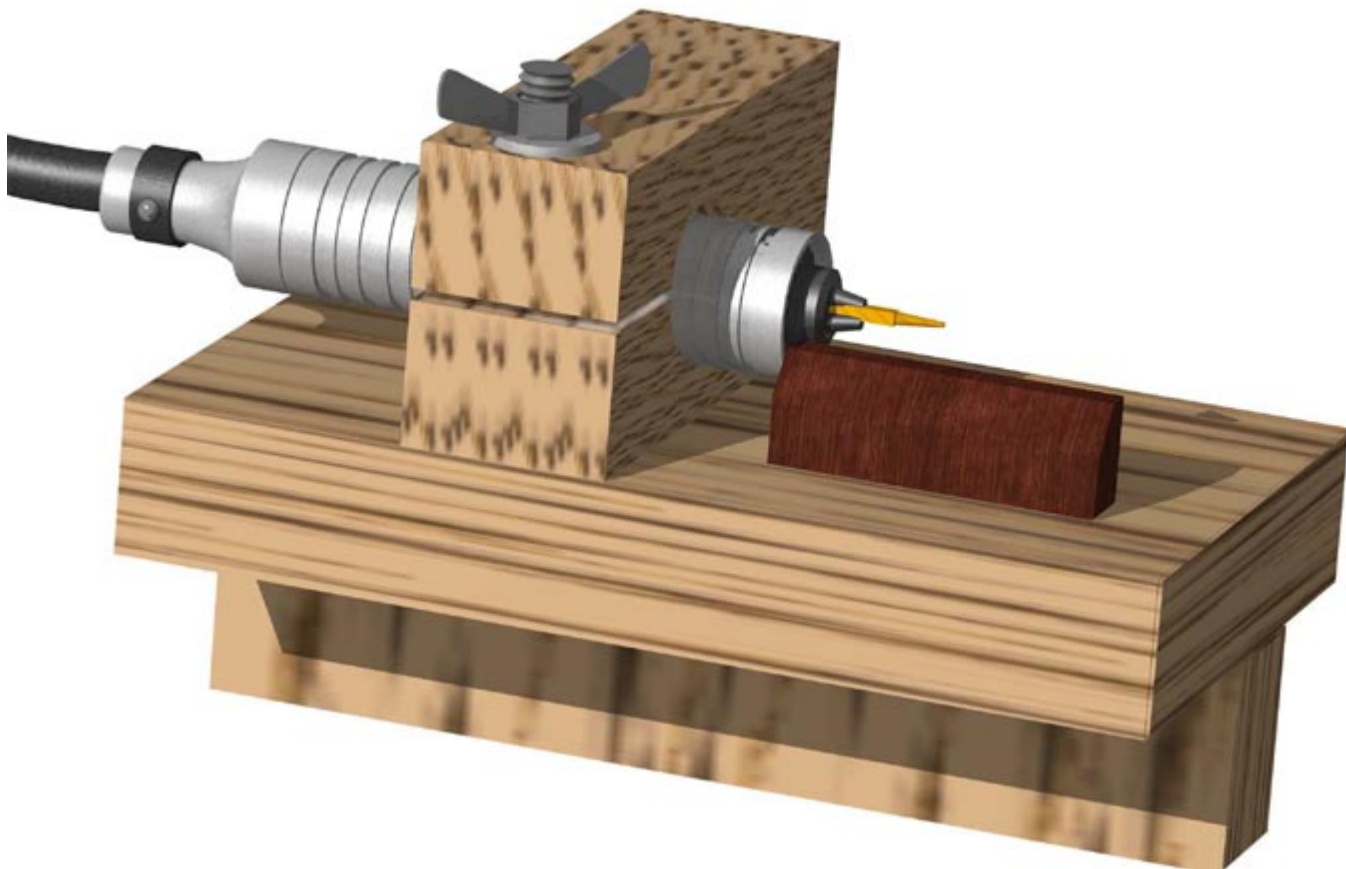

Make your version of the Foredom<sup>™</sup> lathe by drilling a large hole in a piece of two-inch thick wood that's the same diameter as your hand piece. I have a 1 inch Forstner bit that works perfectly for this. If your carving machine isn't a Foredom<sup>™</sup>, your hole may have to be slightly different. Measure your hand piece and adjust the size as needed. The dimensions of this piece of wood should be about 2x2x4 inches. Larger dimensions are OK, whatever you're comfortable with. At right angles to the large hole, and about an inch in from the end, drill a smaller hole to fit a bolt to act as a clamp to hold the hand piece in place. About a quarter of an inch diameter bolt with washer and wing nut will be fine. See the picture for where these holes go. Next, cut a saw slit all the way through the large hole, extending a little past the far side of the hole. You now have a clamp that will hold the hand piece securely. I placed mine on a larger piece of wood, and glued on a tool rest. The only critical measurement on the tool rest is how high it is. You should be able to place your turning tool on the top of the tool rest, holding it at a comfortable angle, and have the cutting edge meet the turned cylinder slightly below the center of rotation. Play around with this until it feels right. The top edge of the tool rest should be relatively narrow, say about a quarter of an inch, and near the edge of the base. I added another piece of wood under the base so I can hold the whole mess in my bench vise.



I use a Foredom number 30 hand piece (the large one with a Jacobs chuck the chuck you adjust with a key like a hand drill). I can chuck small square pieces of wood (grain along the long axis) without any more fuss. Larger pieces will require you to reduce the size and carve them round to fit in the chuck. The other large Foredom™ hand piece with collets (number 44) will also work, but will be a bit more finicky about chucking up square pieces, definitely requiring you to carve them round and to a diameter near the working size of the collet. I use a small straight carpenter's chisel to turn my pegs. Don't forget to turn them with a slight taper, and check them with your calipers until they're the right sizes.

### Pitfalls to watch out for

When you drill your holes, make sure you know which direction you want your eyes to look. If you're not careful, you'll end up with a cross-eyed carving, or worse. Also, be sure to practice on a piece of scrap wood (the same kind of wood as your carving). Be sure and practice with the very same burrs, and in the same order as you're going to use them before you try this on your carving. Burrs larger than one eighth of an inch in diameter are quite subject to harmonic chatter if you're trying to use them as drills, and may enlarge your holes unexpectedly. Be sure you know how yours are going to act before you do the irreversible.

You don't have to limit your inlays just to eyes. Here are some grub worms (carved in ivory) with their heads inlaid in ebony just like tiny pupils in eyes. The worms are about a quarter of an inch long, and the inlay is 1 millimeter in diameter.



Some more eyes. Netsuke aren't the only carvings that are enhanced with inlaid eyes...





### ***Fitting Pieces Together***

If you intend to carve a netsuke out of more than one type of material, you must master the methods of fitting the pieces together in a seamless fashion. Since I don't use paint, I often use contrasting materials to enhance my netsuke.

The technique I use to achieve the good fit necessary to escape notice when closely examined is simply repeated trial and error. I estimate what the contact area needs to look like and carve the surface to approximate that. Once it has a reasonable fit, I move on to a more exacting method. I use carbon paper to show the areas that need more material removed. To accomplish this, I place a piece of carbon paper, black side to the piece I'll be removing the material from, and press the two carved pieces firmly together. The carbon paper will leave a black mark on the high areas, and show where to remove material. In the early stages of fitting I'm fairly aggressive, removing about a millimeter of material at a time. As the black mark gets larger, showing more contact area, I remove less and less material at a time. This process can be very fiddly, but the results are definitely worth it. For dark woods, try to find "white carbon" paper. I've occasionally seen it in specialty office supply stores, although with the imminent demise of the typewriter, this is becoming more difficult. Failing that, try to get some white strike-out typing correction papers. The ones I'm talking about are the small sheets, not the ribbon type. My embroidering friends

tell me dressmaker's carbon comes in red, yellow, white and blue and is easily found in stores that carry sewing notions. There is also a white transfer paper called Saral™, available in art stores. If all else fails, rub white chalk on a piece of thin paper and use that like carbon paper. It is a bit more messy and smears easily, but will work.

Once the pieces fit together well, you must fasten them together. If you intend your masterpiece to last for centuries, you will have to find a permanent method for joining them. I use epoxy glue most often. In museum conservation circles, there is some debate about how long epoxy bonds will last. Many items made using hide and fish glues have lasted for centuries. Epoxy resin glues haven't been around long enough to find out. I risk the permanence issue for strength and durability in the near term. I also believe my netsuke aren't likely to be exposed to large amounts of the worst offenders that cause plastic glue degradation: ultraviolet light (also direct sunlight), and polluted atmospheres. I sometimes use small dowels, pegs, or wires besides the epoxy glue to try for a better bond. You may also find some types of woods do not bond well with epoxy, especially if the woods are quite oily. In cases like that, try washing the contact surfaces several times with lacquer thinner. This will remove the oils from the surface and allow the epoxy glue time to cure before the wood oils re-infiltrate the area.

It is probably a good idea to wash any contact surfaces with lacquer thinner, just to be on the safe side. For pieces with larger contact areas, I also roughen both of the glue surfaces. Often, this takes the form of dimple texture with tiny rotary cutters. Just be sure the texture doesn't extend beyond the contact areas, or you'll have some unwanted texture visible. Once I have applied the glue, I diligently remove any glue that is squeezed out of the joint, usually with cotton tipped swabs, sometimes slightly moistened with lacquer thinner. I say slightly, because you certainly don't want any of the thinner to seep into the glue joint itself. Be careful to remove any cotton fibers at the same time. The cotton swabs often shed. I go to great lengths to make jigs and holding fixtures to apply pressure during the epoxy hardening process. Rubber bands may also work well in many cases. Incidentally, I don't use the "5 minute" epoxies. I want maximum strength, so I use the long hardening time kinds. For very small pieces, I often use alphacyanoacrylate (instant) glues. Another calculated risk. If I were to try epoxy for things like each individual barnacle in a barnacle colony, the carving would take far too long to keep my interest. So far I've had good luck. I tend to think the small pieces are not exposed to great stress anyway. Also, since I wouldn't be able to apply adequate pressure during epoxy curing, I think the instant glue has about as much strength anyway.

### **Dental Amalgam Inlay**

A trick I read about once is to use the same stuff your dentist uses for filling teeth: dental amalgam. This consists of a small capsule with powdered metal and mercury, separated by a thin frangible membrane.

### **WARNING**

**Mercury is highly toxic. Use only in a well-ventilated area, and use a dust mask when cutting and sanding amalgam. When mixing mercury and metal, don't use containers or tools you or your family may use for eating or drinking. Dispose of waste mercury and amalgam properly. Ask your dentist to help with disposal.**

## WARNING

Once mixed together, the mercury dissolves the metal, and makes a thick liquid-like mass. You can pack this material into a routed-out area on your carving, and once it hardens, burnish and polish it. It is very easy to do, and makes a perfect fit. I've used this method on several occasions. To make a secure inlay, be sure to undercut the edges of the inlay area so the amalgam will not fall out as the wood or ivory swells and contracts with humidity. I've heard of people taping the unopened capsule to the blade of a saber saw, and letting the reciprocating action of the saw mix the metal and mercury. This is similar to the machine your dentist uses to mix the amalgam. When I mix the metal and mercury together, I open the capsule and place the contents in a small jar with a smooth bottom. I quickly mix them together with a small dowel, using a grinding motion like with a mortar and pestle. I use my leaf-shaped scraper to spoon the amalgam into the inlay, and press it firmly into place. Work quickly. You only have a few minutes before the amalgam starts to harden. Be sure to pack it well, and use a smooth metal rod or other tool to burnish the surface of the amalgam as it hardens. I like to leave a small amount above the surface, to be removed by my standard cutting, sanding, and polishing methods later. Once fully hardened, additional burnishing will make the surface appear smooth and shiny. While the dental amalgam doesn't seem to ever take on a really bright mirror finish, once hardened overnight you can polish the amalgam to a high luster. This method looks especially good in dark woods. I like to use it for eyes. Incidentally, the amalgam is available in several colors, including gold and silver.

### **Gold and Silver Leaf Inlay**

Another method I use is also borrowed from my dentist. Early fillings were often made by packing 24 carat gold foil into teeth. Dentists today occasionally still use gold foil restorations, and they have small electric hammers for the packing. For very small inlays I simply use gold leaf, and pack it tightly into an undercut inlay area. It will pack quite easily, and adhere to itself well. It will take several sheets of gold leaf to fill even a small inlay, so it may be prohibitively expensive for larger areas. For larger inlays, it is probably more cost effective to obtain the gold foil from a jewelry supply company. Once filled, I burnish the surface with a smooth metal rod, or an ukibori punch with polished tip. I used this method to make gold pupils in the silver octopus in *Octopus on Broken Pot* (see **Pattern Pages**). You can also use silver leaf with this method as well. Gold and silver leaf can be obtained from art supply stores.

### **Making Barnacles**

One of the easiest and most dramatic things to add to marine subjects is a colony of barnacles. I use them extensively in my marine carvings, and with great success. The best part is they are easy to make. They really dress a carving up. The top group of barnacles is from the back of the Hermit Crab. The second group is from the Octopus Pot (for both carvings, see **Pattern Pages**).

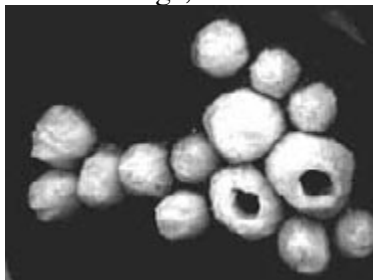

**Carved Barnacles (Left and Center) Real Barnacles (Right)**

All you need are some small wood dowels, some instant glue and a material that contrasts with the main part of your carving. I've used ivory most often, but light colored woods (like boxwood or holly) or bone will work fine too. With a bandsaw, I cut small blocks of ivory just slightly larger than the barnacles I want to make. I glue these onto the flat end of one of the dowels with instant glue so I have something to hold onto. Some of the barnacles are quite tiny. Then I carve the outside of the barnacle block into a cone or volcano, the basic shape of a barnacle. I make them with 4 to 6 sides on the bottom, and tapering towards the top. In general, a diamond shape. Just don't leave them square. The angular bottoms will help you put them together into a close fitting colony later on. Often a fine structured carbide bit will work well, because one of the things we will eventually do is put vertical lines along the taper. The structured carbide does much of this for you. With a small ball cutter, I carve a trench around the flat top of the volcano shape, and slightly oblong to represent to opening parts of the barnacle shell. Depending on the size, you can detail this as much as you like. For some in each colony I use the ball cutter to drill all the way through, simulating the dead ones you always see in a barnacle colony. Be sure to vary them, both in shape and size. After the basic shape is complete, I add random vertical lines to represent the plates that barnacles are made of. You need quite a few of these for convincing looking barnacles. Be sure to look at a sea-shore guide for photographs of the various types of barnacles. I often do this with a fairly stiff wire brush. When the lines are in, use a sharp knife to cut the barnacle free of the dowel. I generally do this inside a shoe box, because the barnacle always pops off and flies into the nearest pile of sawdust. If the barnacle is going to be applied to a curved surface, use a diamond or ruby ball cutter to cut a shallow concavity on the base. Then glue it onto the netsuke. You will need quite a few to make a convincing colony. Once I have a few glued in place, I try to cut the rest so the bases will fit fairly closely together. A nice touch is to make sure the barnacles you apply are the kinds you would find with the other subjects of your marine netsuke carving. Don't put Pacific Ocean barnacles with an Atlantic octopus scene.

**Ukibori Bumps and Warts**

The old netsuke masters developed an interesting technique raising small bumps and lines on wood and ivory carvings, called ukibori. No one living today has yet been able to completely recreate all the seemingly impossible things the old carvers were able to do with this technique, but the basics are understood. The best of the old masters were able to create tiny raised bumps as texture, and even raised writing. They are so perfect and tiny, to see some of these in person is quite a humbling experience. Some contemporary carvers are using the ukibori technique, but none yet have produced anything like the old masters. Although the basics are quite simple, good ukibori is definitely an advanced technique that will require practice.

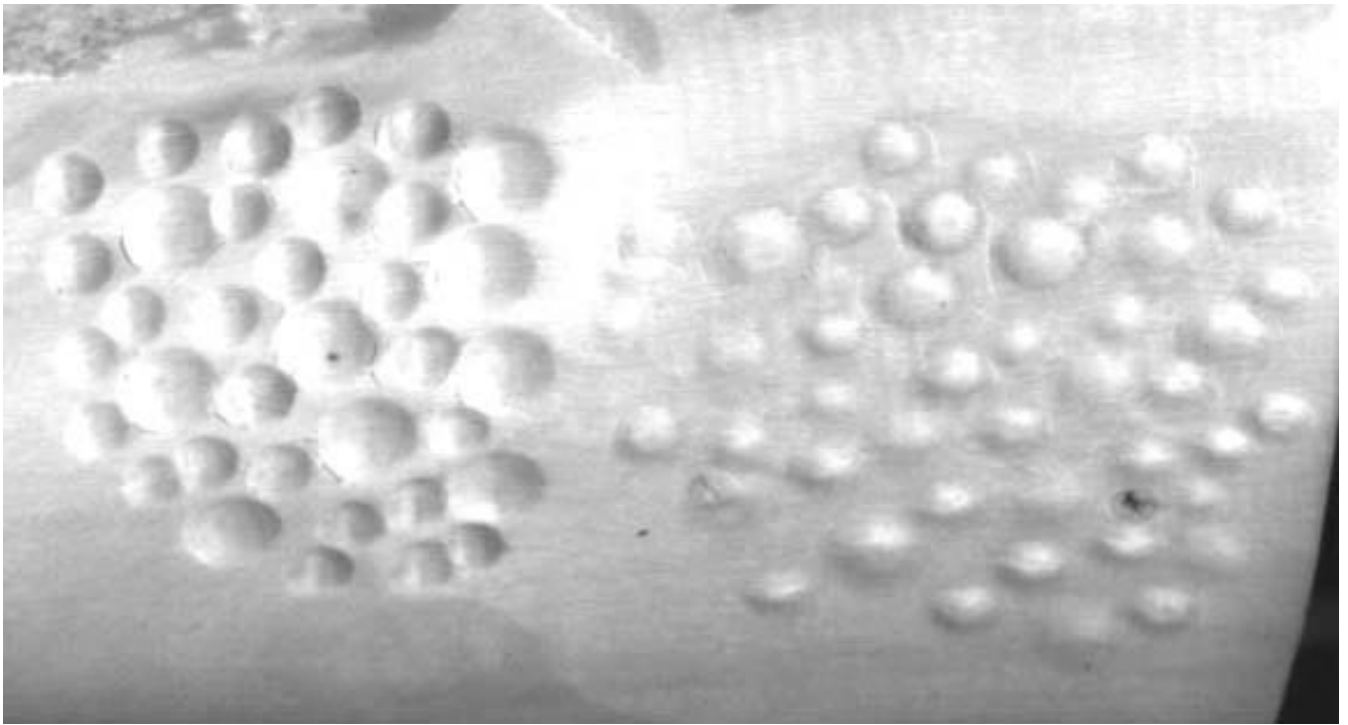

**Left side punched depressions, Right side raised bumps after wetting**

### **Wood Ukibori Techniques**

The technique for wood goes like this: using a hard punch with a very smooth rounded end, the wood is depressed a small amount beneath the surface. This often requires a firm tap with a mallet. The surface is then carved down level with the bottom of the depression formed by the punch, and the area of the depression was wetted with boiling water (use a small brush). Wetting the surface should be done soon after punching. The longer you wait, the less chance you have of succeeding.

Don't punch the depressions in the evening and then try to raise the bumps the next day. Since the wood in the depression was compressed, it was not cut away when the surface was lowered. The crushed wood fibers will swell up when wet, creating a bump above the surrounding surface. The secret to successfully using this technique is knowing how much you can depress the wood fibers without breaking or cutting them, and using dry wood. Green or wet wood won't swell up after being compressed. In addition, you need punches the size of the bumps you'll be making, and of the right shape. The dangers of the technique are that in tapping the punch on your nearly completed netsuke, you run the risk of splitting it or breaking off vulnerable parts. If you experiment with these techniques, don't forget that you can make any shape of bump you like by altering the shape of the punches. A round, hemispherical punch will make a circular bump, and an oblong one will make an oblong bump. Straight and curved lines can be made by repeatedly joining oblong punch depressions. I haven't seen ukibori punches available commercially, so these are tools you'll have to make for yourself. Fortunately, they're easily made. Simply take a piece of steel (a nail will do), shape the tip to the size and shape of the bump you want, then smooth and polish it. Leaving sharp areas on the tip will cut the fibers, rather than depress them, spoiling the effect, and maybe your carving. Definitely practice on some scrap material carved to the same basic shape as your netsuke. This will

give you a feel for how deep to make the depressions, and how likely it is the punch will slip and skate off the surface (breaking of the nose of your subject, of course). Generally, you can only depress the surface several millimeters without cutting and crumbling the wood. In addition, the swelling of the wood fibers is variable at best. It works well for naturally varying features, like the warts of a toad, or the texture of a snail's body, scales of a dragon, etc., but trying to use ukibori for very regular or man-made features may be asking for trouble. Also remember that the ukibori bumps and warts are made from damaged wood. They are not nearly as durable as the undamaged wood surface, and may be polished away, or worn off during handling. Even though subject to early wear, don't be afraid to use ukibori in your work. Wear and the dirt and grime we call patina have added immensely to the appearance of antique netsuke; yours will be a good-looking antique someday, as well.



**Detail from Hermit Crab (see Pattern Pages)**

### **Ivory, Bone and Metal Ukibori Techniques**

For these materials, ukibori is basically an acid etching process. The raised part of the design is masked with an acid-resistant substance (called a mask), and the piece is placed into an acid bath. The areas not covered by the acid-resistant mask are eaten away, and the masked areas end up above the surface of the surrounding areas. These techniques can produce spectacular results, but like everything worth doing, they require practice and experimentation. I've used both sulfuric and hydrochloric acid with ivory and metal. I've never tried bone, but I don't see why it shouldn't work. Hydrochloric acid is available through hardware and swimming pool suppliers as muriatic acid, a commercial grade of hydrochloric acid. Sulfuric acid is available through chemical suppliers, or perhaps your druggist could obtain it for you. For acid resistant masks, I've successfully used wax, lacquer, and fingernail polish. The wax is much more robust, and can resist the attack of the acid indefinitely, but is harder to apply. I use paraffin wax (the candle and candy-making kind), either straight or dissolved in a small amount of warm turpentine or other wax solvent. If you dissolve the wax in a solvent, it will be easier to apply where you want it with a pointed tool, artists India

ink pen or small brush, but is thinner and not as acid-resistant. Heating the wax/solvent mixture will help in spreading it. However, be careful in heating it, since the solvents are flammable. Use a double boiler, and keep a fire extinguisher handy! Using pure wax is useful for small, circular bumps since it naturally forms those shapes, but any other shapes are tricky. You may also be successful covering a large area with wax, and scraping away the wax in the negative areas (those areas that will be eaten away by the acid). Be sure to put the mask on areas you don't want touched by the acid, as well as the ukibori design. You don't want to make some lovely ukibori designs only to find out the acid has eaten away the rest of your netsuke because you forgot to cover the rest of it with the mask!

### WARNING

**Be certain to wear eye protection, gloves, and an apron when handling acids. Concentrated acids are dangerous, and produce hazardous, caustic fumes. If you are going to dilute acid, ALWAYS, ALWAYS ADD ACID TO WATER, never vice versa. Failing to do this will produce an extremely violent reaction, dangerously spattering acid everywhere!**

### WARNING

Also, experiment with the amount of time you leave the piece in the acid, and the concentration of the acids. If you'll be using nail polish or lacquer, you'll definitely need to use about 50/50 acid and water mixture or less, since concentrated acid will quickly float the lacquer mask off the surface. For ivory, I've generally found about 30 minutes is the longest time I've needed to produce bumps about a millimeter high. This will vary with concentration and temperature. Warmer acid is more reactive than cold. Continually take the piece out of the bath and test it to see how far along the process is. Ivory will not be completely removed from the surface. It tends to become soft, rather than be eaten away, so you will have to use a small sharp-pointed tool to test the softened surface. Once the acid has gone deep enough, remove the piece from the bath and rinse it thoroughly in clear water. Once it is rinsed (and still wearing your rubber gloves!), scrape the softened areas to remove the skin. The acid-soaked areas will remain soft as long as they are wet; if an area dries out, wetting it with clear water will soften it again. The tool you use to scrape the softened skin off can be anything handy, but I've found a small, sharp scrap of the same material as your netsuke is the best. Shape it to make a chisel-like surface. Being of the same hardness as the unaffected parts of the ivory or bone, it won't make unwanted scratches and scrape marks. Continually wash the sticky, softened scrapings off the surface with clear water. Once you are finished scraping, wash well with liquid dish washing detergent and water, and let it dry for 24 hours. After that, you are ready for final carving, smoothing and polishing. Be careful, however. Your hard won ukibori bumps and lines are not large, and are easily carved or polished away.

### *Adding Elements to Carvings: Ladybugs*

While a lot of my carvings are one piece, with the possible exception of eyes, I sometimes need to add additional elements to carvings. In this case we'll examine my method for making ladybugs, although these principles will obviously be of use for other subjects as well. Since these additions will stand proud



from the surface and be exposed to wear and damage, I'm quite concerned with making them very sturdy, especially their attachment to the surface. I don't need the pain or enmity of clients because of items being broken off or damaged on an expensive piece of work.

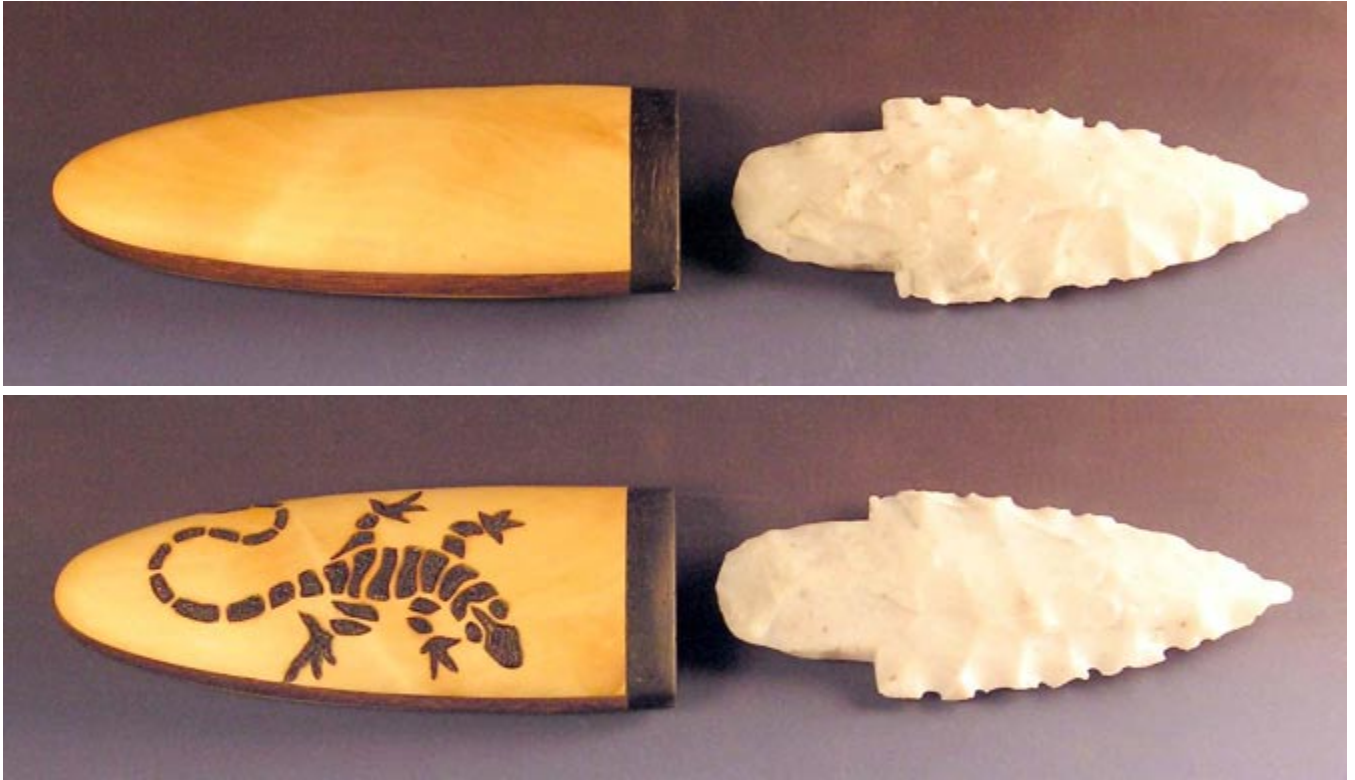

Here is a small stone-bladed knife with a pyrographed lizard on one side. I often like to portray natural subjects in their natural adversary predator/prey relationship. In this case, the lizard will be hunting a group of insects (ladybugs). In the past I've used other bugs like ants, beetles or spiders.. I've chosen to represent the lizard in a rather stylized manner, and the ladybugs in a more realistic setting. I often like this juxtaposition of artistic styles in one piece. It seems to add a certain tension. Above are the stone blade and the handle blank (yellow - English boxwood, center core - black walnut and black guard - ziricote). I'll be adding ladybugs, coloring them and adding dark pegs for their spots. The pegs will also do double duty by providing added strength in attaching the ladybugs to the surface of the carving.



I've chosen to use moose antler to construct the ladybug's bodies out of. There's a little method to my madness here. The hard outer surface of the antler is quite resistant to damage and wear, is porous enough to take stain fairly well and is pretty white so it won't interfere with the colors I'll be using. Above are the beginning stages of ladybugs. At the bottom of the image is a small block of raw antler, the hard outer layer. I sanded the base flat and used gap-filling cyanoacrylate glue ("super" glue) to attach a block to a piece of 3/16 inch dowel straight from the hardware store (top of the image). I sanded the end flat to obtain a good fit for a strong glue joint. In the center is a roughed-out ladybug I sanded to shape using a disc sander. You could carve it as well using a rotary grinder and various burrs. One of the major problems I've often faced in netsuke carving is holding and manipulating small pieces. If I hold such things in my fingers I either end up getting blood on them, or they go flying into the far corners of the studio and bury themselves in a pile of sawdust, never to be seen again. A temporary gluing to a sacrificial holding device solves a lot of the problems.

A wood like boxwood could just as easily be used, however in this case I would bleach its normally yellow color to white, since I'll be coloring the ladybugs red and the boxwood's yellow cast would change the red to an orange. I'm sensitive to this, since the general perception of the public to ladybug color is "red," although I've never seen a red ladybug in real life or in a photo, only orange ones and yellow ones. Trust me on this, I'm speaking from experience. I could have sold this ojime a dozen times over, except I portrayed the ladybugs in an accurate orange color, and got lots of comments that the color should be red. Live and learn - client perception is often more important than biological accuracy. Go figure.



**Some other ladybugs**

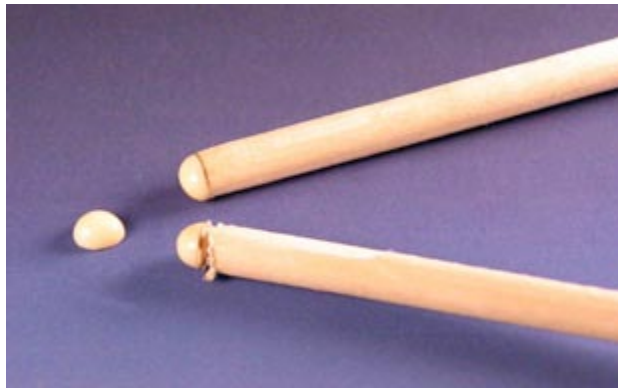

Here are shaped and polished ladybug blanks. I've concentrated on getting the overall shape correct and have sanded and polished the surfaces while they're on the dowels, since once they're glued in place, getting polishing buffs into the nooks and crannies will be difficult (top in the image). I'm not going to worry too much about making a bug an entomologist could differentiate down to the species level. My ladybugs are going to be relatively simple, and I'll just strive to obtain the "essence" of ladybug. Once the bug blank is ready to take off, I use a small diameter burr to carve away the dowel just below the bug's base, leaving a small peg (bottom of the image). I can then break or twist the bug off the dowel. Next, using a sharp knife, I trim away any remaining dowel and glue, being certain to scrape away all of the glue. Cyanoacrylate glue is convenient since it sets fast, especially using a glue accelerator, but this type of glue doesn't have good strength characteristics. I'll be gluing the bugs on with slow-setting epoxy for strength and any remaining cyanoacrylate glue on their bases will interfere with a good epoxy bond, weakening the work.



In this image, I've carved away an area where I'll be burning a bark texture down into the handle blank.

The center area I'll carve flat and smooth to match the flat bases of the ladybugs to ensure a strong glue joint. I'll be placing a group of five on this side, with one on the lizard side.



Here's the bark burned in. I've burned the edges using a fairly high temperature, really burning deeply for texture. I've burned at a much lower temperature, looking only for color and not texture, again for a good glue joint.

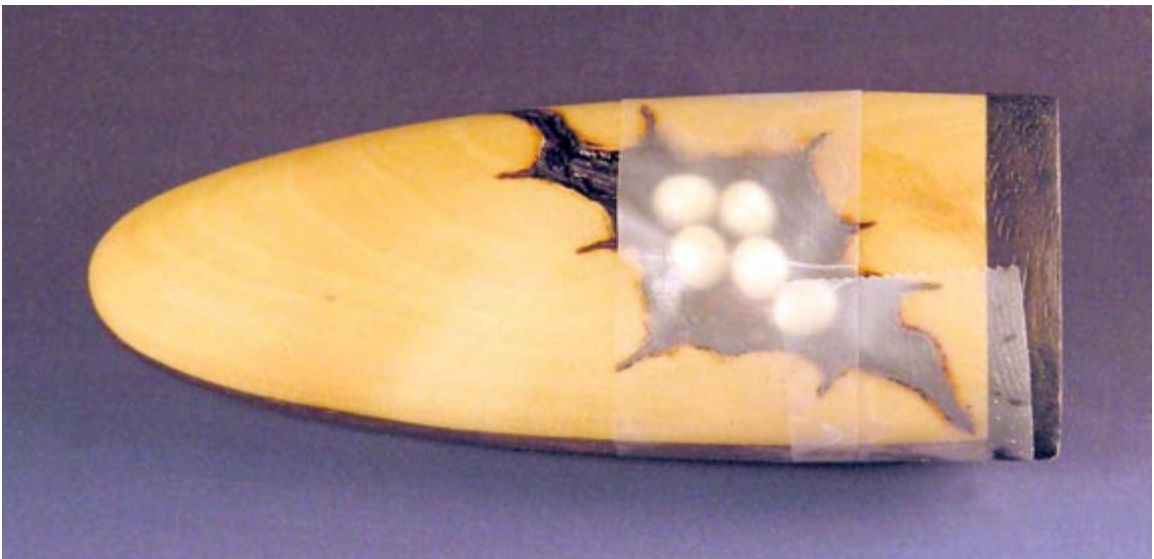



I've glued the bug blanks on using a slow-setting epoxy. I don't like the five-minute epoxies because I feel they don't provide as strong a glue joint as a slow-setting type. Another problem common to netsuke carving is holding small elements in place while the glue sets. Here I've used cellophane tape. I also often use small spring clamps, rubber bands, string or thread, or whatever I can cobble together. This sometimes requires a bit of creative thinking.





Here are the blanks glued in place. I've waited about four hours since gluing. The slow-setting epoxy isn't completely cured yet, but I'll be going back in with small, sharp scrapers and removing the excess glue around the outside of the bug blanks. I often find this is the best time, since the epoxy is still slightly soft and tacky, and is more easily removed without damaging the surface below. However, you do run the risk of weakening the bond. I'm satisfied with taking the risk in this case, since I'll be pegging the ladybugs into the wood to aid the epoxy.



Above, I've drawn in the basic shape of the ladybug's head with a pencil, as well as the dividing line between the wings. I have a number of ladybug photos for reference to get the proportions correct.



Using my tiniest burr, I've carved grooves where the pencil lines were, and about the depth of the diameter of the burr. I'm really just looking for a hint here, since the bugs are quite tiny.



While I still have my tiniest burr chucked up, I've carved/drilled three holes in each of the ladybugs. One is just behind the meeting place of the head groove and the wing dividing line. These are the starts of the peg holes. I've carved/drilled holes with the next size burr and enlarged each hole successively until I reach the desired hole size. I like to use successive sized burrs for accuracy, since I find it too easy to wander if I use the final burr without resorting to the smaller pilot holes. I've chosen to show only three spots since any more will be ridiculously fiddly and onerous to do, and won't really add anything to the carving.



I'm ready now to begin making the pegs that will both hold the ladybugs in place mechanically and provide the dark spots.





Above is the setup I use with the bandsaw to cut the small pieces of dark wood I'll make the pegs out of. The peg wood is the dark piece in the center. On the left is a small piece of scrap wood to guide the peg with. On the right is another scrap that I've cut a notch in to push with. These keep my fingers away from the blade. Cutting small pieces like this is very dangerous without such guiding and pushing sticks, since your fingers would be just millimeters away from the blade! Since the pegs are so small, they often become jammed behind the blade or fall into the throat opening. If this happens, shut the saw off and let the blade stop moving before attempting to extract the peg. Let's not lose any fingers or friendships over this!



Here are the cutout blocks for the pegs. We have six ladybugs with three spots (pegs) each, so we'll need

a grand total of 18. I've cut a few more since I invariably mess at least one up, although my waste pieces are getting fewer. Each of the pegs above is between one and one and one half inches in length, and maybe three sixteenth inches wide.

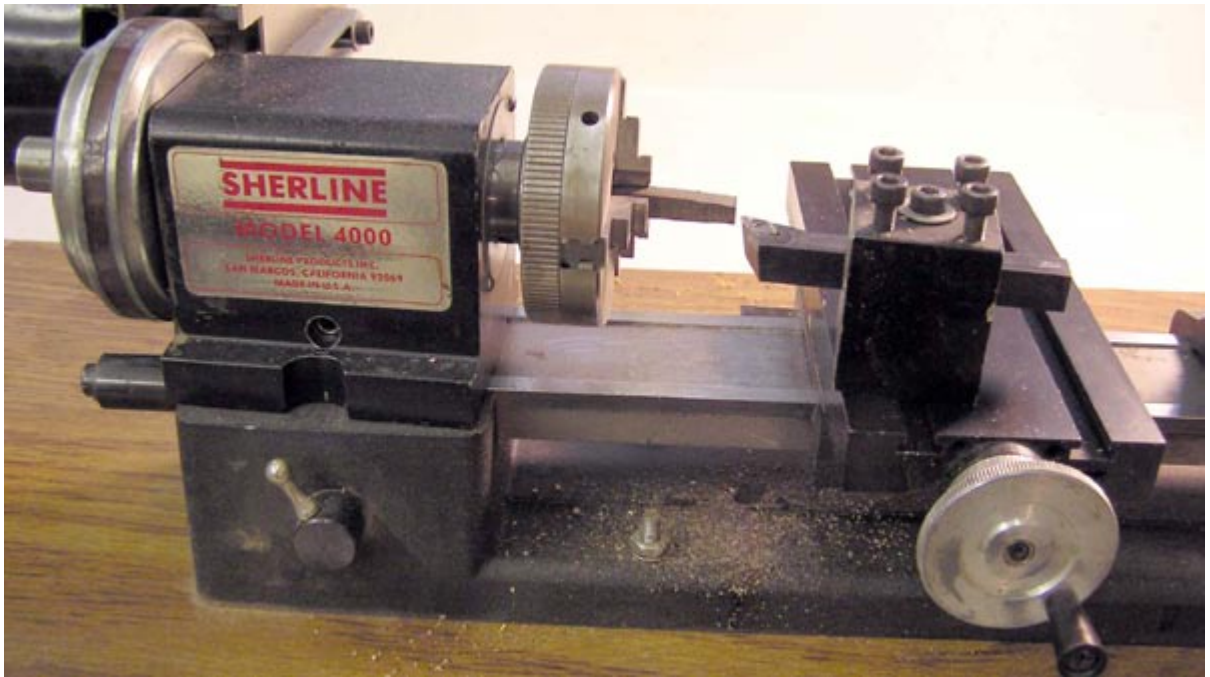
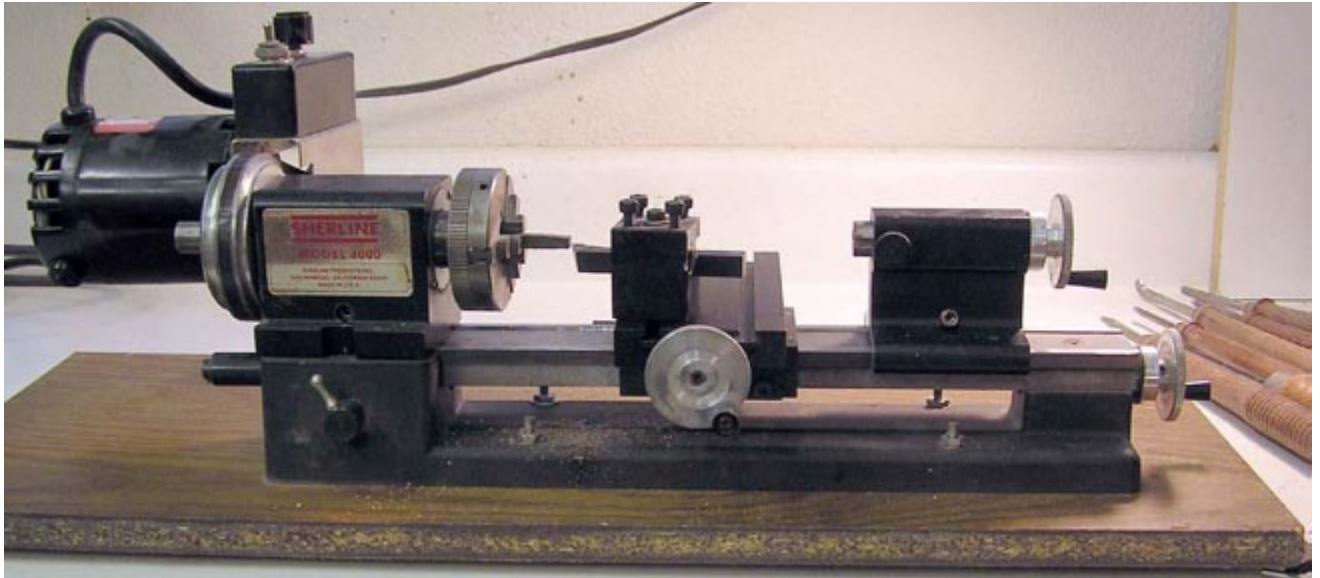

I use a Sherline metal cutting lathe for making the small tapered pegs we need. I simply place each approximately square peg in a three jawed chuck and turn them round. The tiny Sherline lathe is absolutely perfect for this operation, and chews through wood like it was butter.

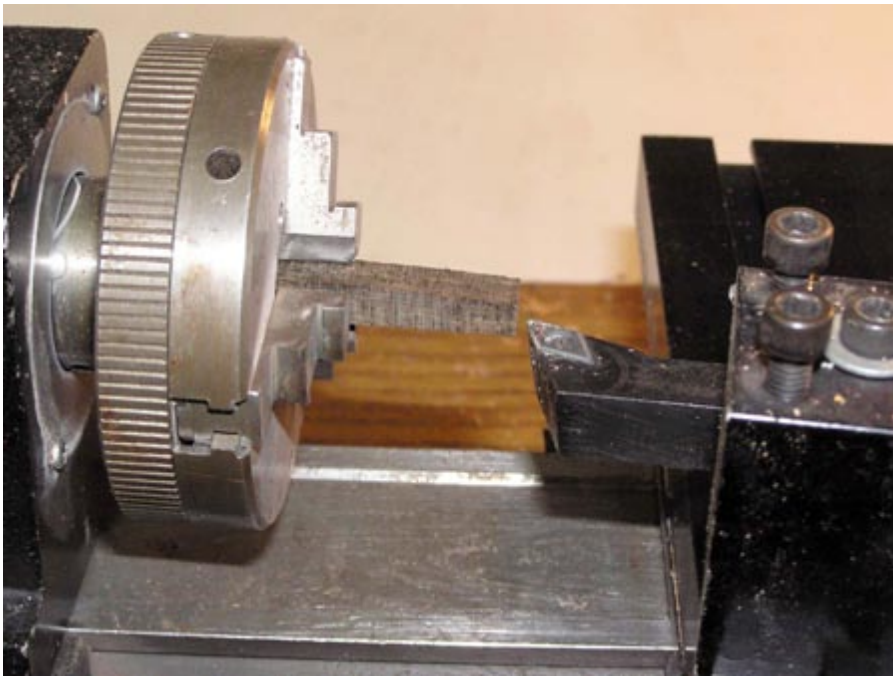

For turning tapered pegs, I simply rotate the Sherline headstock a few degrees clockwise. This is a feature that seems unique to the Sherline lathe. See the blue arrow above and note the small angle the headstock makes with the base (near the arrow).

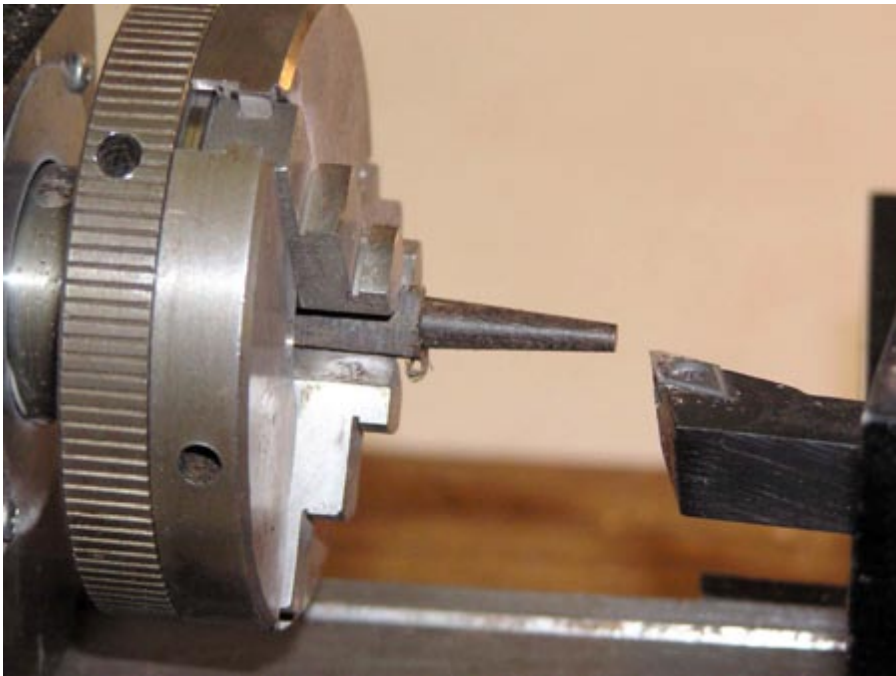

I turn the square pegs round, leaving the tapered peg fairly thick, as above.

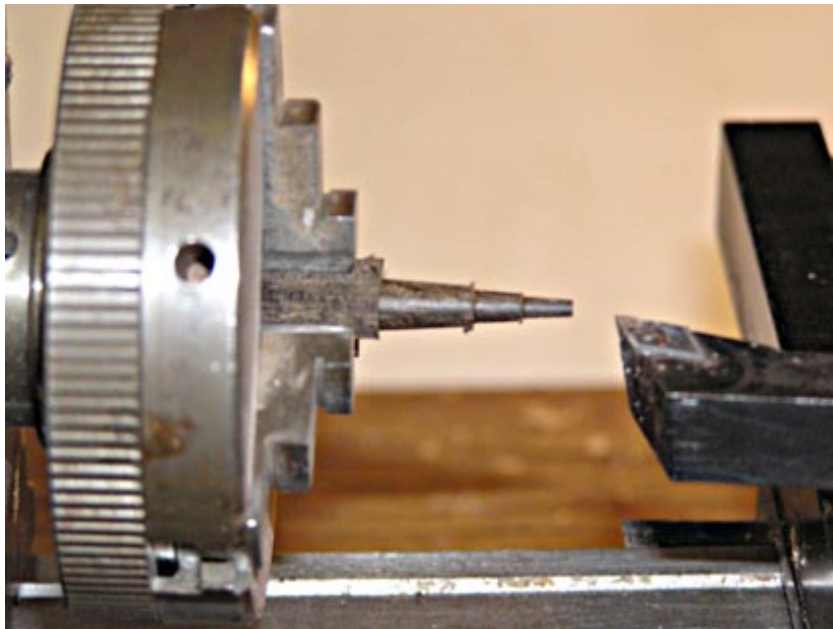

At this point, I reduce the thickness of the peg in small steps, as above. Since the pegs we need are much smaller than a pencil lead, I have to approach the turning like this. As the peg becomes very thin, the wood will flex away from the cutting tool and not be cut. Steps like above leave the wood thick enough not to flex very much.

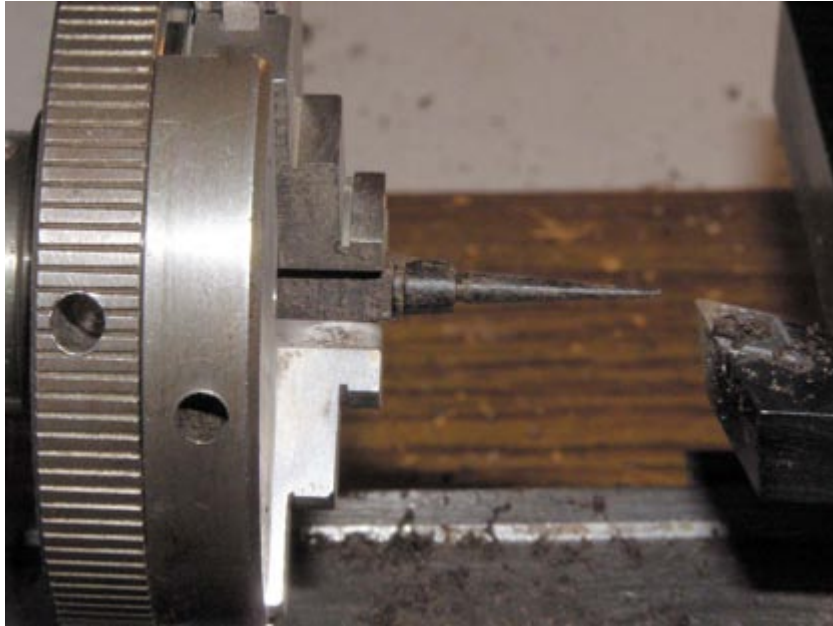

I adjust the crossfeed with the cutting tool at the very tip of the stepped peg until I'm cutting almost a sharp point on the peg. Now as I cut the peg towards the headstock, the thick steps will keep the very thin peg from flexing away from the cutting tool. When the peg is complete, I make a shallow cut into the peg's base (see the inset picture above). This will allow me to snap the peg off without damaging the very thin wood.



Above are all of the pegs I've turned. The entire group took about 45 minutes.



Here, I'm gluing the pegs in place. I've carefully searched through the pegs to find six of the longest and thinnest ones to glue into the hole that continues through the bug and into the wood. Some of the pegs aren't thin enough for that critical position, and will be used in the other spots. I use slow-setting epoxy here for strength, using a small diameter wire to make sure the glue gets all the way to the bottom of the mechanical holding peg hole, and smear additional glue on the surface of the pegs to ensure a strong bond.

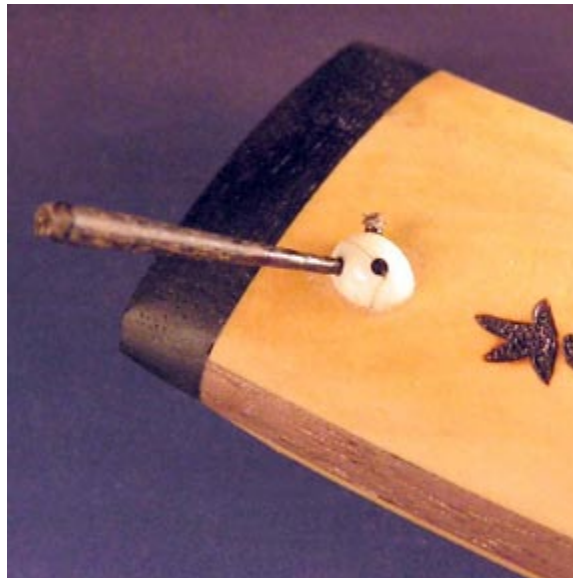

Now that the epoxy has cured, above are examples of the three stages handling the long pegs. The long

peg is untouched, and I've used a small burr to cut the center peg near the bug's surface, leaving a little above. Be careful not to let the burr get out of control here, or you'll scar the bug's surface. The spot on the right has been carefully cut down to the surface, using the same small ball burr and a long, thin flame-shaped diamond burr sander.



Above are the completed spots.



Here are the ladybugs on the back side. I carefully fit the important mechanical holding pegs first, then

added the rest. I've managed to get all but one peg into the holes, and can't quite manage that one, since the other pegs are blocking it. This is fairly unusual, since this stage usually takes about three gluing sessions. This forest of pegs has an interesting look all its own, so I'll remember this for a future project. I'm all set to log and clearcut this forest!



Here are the completed spots, ready to be stained.



At this stage, I've painted all the antler ladybugs with white vinegar (the cooking kind from the grocery store) to etch the surface to allow better stain penetration. Just paint it on the antler (works for ivory as well) and let it dry - not getting any on bare wood, of course. You'll notice an immediate dulling of the polished surface. I've also been very careful to remove any excess glue, since a glue coating won't allow



the stain to penetrate, leaving white, unstained places. Following the vinegar treatment, I used a fine-tipped dip pen and sumi ink to line around the head and the wing dividing line. I inked them after the vinegar to avoid dissolving the ink and making a runny mess. The vinegar seems to dissolve the ink, but the dye won't.

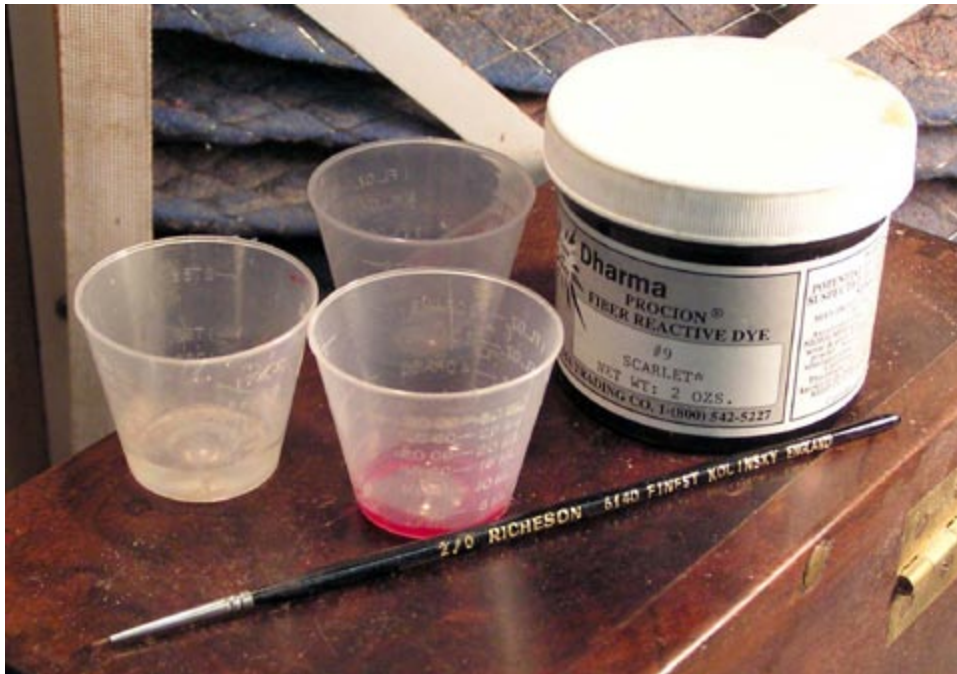

Here's my dye setup. I use little medicine cups with a knife tip's worth of dye and a few drops of distilled water. I wouldn't use tap water, since you may get some unpredictable and unwanted adverse reactions. If you have trouble getting the dye liquid to wet the surface, try adding a little TSP (Trisodium Phosphate). We're making less than half a milliliter of dye, so don't go crazy. With the amounts of powder the dye comes in, at this rate one container of powdered dye will last a lifetime.

I'm using a high quality fabric and fiber-reactive dye called Procion™ MX. This dye is available in many colors, is easy to mix and isn't bad about rubbing off on other materials. Other commonly available fabric dyes like Rit™ are easy to obtain and will work, but I've found them to rub off on other materials which come in contact with the dyed surface. My dye palette consists of Dark Brown, Scarlet, Lemon Yellow and Sky Blue Procion™ dye. These four colors, when mixed in differing proportions give me every color I want.

Add dye if you want more saturated color, distilled water if it's too concentrated. I like to have a scrap of the same material I'm carving to test the dye on. You never know what's going to happen until you test. Even the same types of material from different sources can vary markedly. When all is satisfactory, I use a tiny paint brush to apply the dye with. The one I like best is a 2/0 sable.



Above, I've painted one coat of dark-colored dye on the ladybug heads. I mixed the dark color here from the brown, scarlet and blue, equal amounts of each, yielding a sort of eggplant color. It will take several coats to make the heads really dark.



Here's the front side ladybug, with both dark head color and red. I show this side because it is a special case. The back grouping of ladybugs is surrounded by dark burned wood, so any overflow of dye won't really hurt anything. The front side, however, is a different matter. This ladybug is surrounded by light-colored wood. Here, an overflow could make a real mess. Be careful and apply dye sparingly, sneaking up to the edges.



The back group with a single coat of dye.



The color won't ever be really strong on this kind of dense antler (or ivory), but I don't really want a highly saturated color, anyway. I prefer things to remain a little muted, subtle and (hopefully) elegant. The problem to watch out for here is small areas of glue on the surface of the antler, as you can see in the yellow circles above. I missed that area in the cleanup. Just take a small scraper and remove the glue along with a little surface area, then reapply more dye. That should fix the problem.



Here's the finished knife, with a coat of a Danish oil finish applied (mostly linseed oil).

### *Carving the Spawning Sockeyes Netsuke*

Here's how I often design a netsuke from start to finish. After deciding what subject and a general conformation of what I'm going to work on, I gather reference material. I've found the World Wide Web (Internet) is a wonderful resource, especially the image search options in search engines like Google. They allow me to search and review lots of pictures, as well as specify the approximate sizes of the available images. I often make composite groupings of the images I've chosen as reference and print them out. Here's a small version of the reference sheet I'm using. I didn't keep any information as to the sources of the images, and so to those artists and photographers whose work I've blatantly plagiarized, my sincere apologies. Please take comfort in my appreciation of your efforts to make this information available to others. Thank you!



For this work, I cobbled together a model for reference. I don't normally produce models, since I often feel that once the model is completed, I've already created the work and rapidly lose interest. Some of that attitude comes from my experience with models in the past. I either used plasticine modeling clay or ceramic clay. Both have their drawbacks. The plasticine modeling clay (you know this stuff from kindergarten) is easily damaged and collects carving dust like a super magnet, rapidly obscuring all your hard-won work. The ceramic stuff isn't as bad about dust, but I invariably drop the model or knock it off my carving station, shattering it beyond repair. However, in this instance I tried a new approach that wasn't available when I started carving. I made this model out of polymer clay, a new material that works as easily as either plasticine or ceramic clays, but has the advantage of being able to be "baked" in your home oven, becoming the consistency of hard rubber.

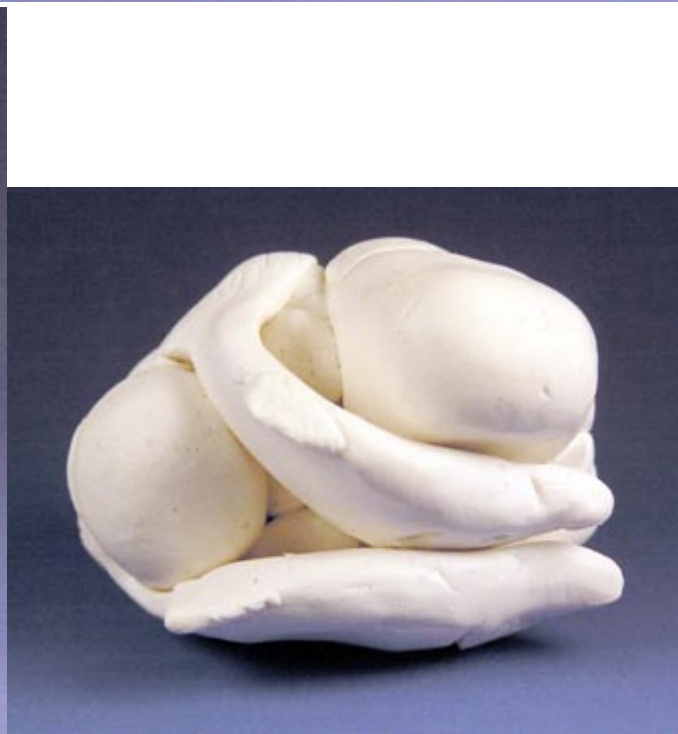



I rather liked this approach, since the model is nearly indestructible. I also discovered it has the advantage of being carvable, so as I "lived" with the model for awhile, the little changes that always become apparent can be made. You can also add more unhardened clay and bake the whole thing again. I noticed on my model that there were a few things that needed changing. Some changes I'll simply make to the netsuke as I carve it, but some I made by carving away the clay of the model. For instance, the large boulder to the left of the sockeye salmon was simply too large and gave the netsuke a clunky look. Also, I felt there were too many rocks on the bottom of the netsuke, so I carved away the ones I didn't want using my rotary grinder. I didn't like the looks of the left salmon's tail (it twists to the left), so in the finished piece I'll carve the tail twisted the other way. Here's the revised model, and (mostly!) in the conformation I'll use to carve the netsuke in.



I've noticed the right pectoral fin on the right-hand salmon looks bad, so I'll have to allow for the rock it rests on to stick farther out so the fin can stick out from the fish's body in a nice, sweeping curve. Rather than add on more clay and rebake, I'll just remember to leave space during carving. Living dangerously can be so exhilarating! I've also reduced the size of the large boulder and excavated under, adding a cray-

fish. Notice I've also severely reduced the number and sizes of the rocks underneath the model. I've left lots of room in between in order to add lots of little salmon eggs (made of pink and red coral) at one of the last stages in carving.





Here's the model and the piece of English Boxwood I've chosen to carve the finished piece in. I've shaped the wood very roughly to conform to the outer dimensions of the model. I've coated the wood with linseed oil to minimize any cracks due to humidity changes since it may be a while before I actually can start carving.



Above, I've begun establishing the basic planes of the elements of the carving. I've very roughly drawn in the positions of the salmon, and have begun establishing the rough placement of the rocks. Notice the fish are being established first, since everything else in the composition depends on them. I'm establishing only the top surfaces so far, since I can always carve further downwards and reduce how high up the fish are in the composition, but once I begin carving the undersides they are locked in place. Any corrections that can be made after that are only to reduce them in height, but not position. This is a basic tenet of carving: work on only one side (or top or bottom) of an element until the positioning is correct. Once you begin working on the other side, your options are instantly reduced! A word of note: I never try to simply replicate the model. It is only for rough reference, and really only used during this stage of roughing out. I'll allow myself to wander away from the model as the spirit moves me in the later stages of carving.



In the above sequence, I've been refining the establishment of the major masses and planes of the elements. Notice in the head-on shot I've now carved on both sides of the inside salmon. I now have no option of moving it left or right, I can only narrow the existing shape. Hence the basic tenet of carving on only one side until you're satisfied with it's position. If I wanted to move the inside salmon left or right,

I'd be stuck with it now. Notice I've added a little more curve to the heads than is in the model. I told you I'd begin deviating from the model!



Here are the only tools I've used in the carving so far. I've used the spherical ball burr the most, with a little bit of use of the flame burr. It does a little better job on flattish planes, and the tip can be used to cut narrower grooves than the ball burr. At this stage I try to follow the artist's rule of thumb to use the largest paintbrush possible. Of course, my paintbrush works in 3D, and I can't paint out my mistakes.

That's a full day's carving, so it's time to stop for now.



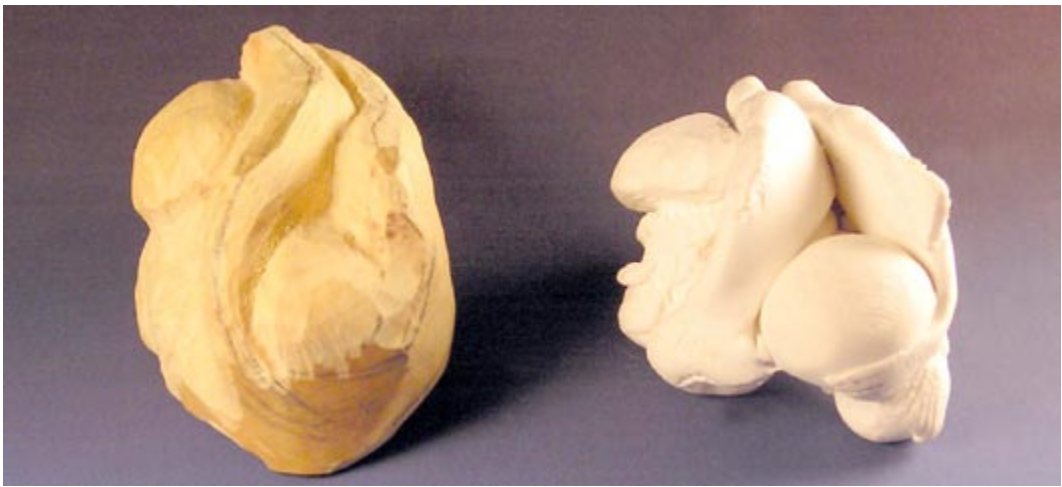



Here are the next steps. I've continued refining the masses and planes, constantly referring to the model and the reference pictures. I'll begin deviating significantly from the model from this point on. I'm beginning to pay particular attention to rounding off all surfaces, keeping in mind that a large portion of the experience "viewing" a netsuke is the tactile aspects. It should feel wonderful in the hand, with no sharp points or delicate (and breakable) features. I'm working hard to avoid the beginner's mistake woodcarvers call "profiling." Profiling means the piece takes the overall shape of the original block of material. That's why so many beginning woodcarvings look so blocky. I'll continue to refine the overall shape, often just feeling it and removing or reducing any area that doesn't feel right.







Continuing with the refining, and I'm beginning to make decisions that can't be altered. From here on, things are being set in concrete. Notice the tails - I've radically altered the inside fish by flipping the tail the other way. In the model, you'll notice the tail twists to the left, and in the carving I've twisted the tail to the right. I've also made the decision to have the outside fish's tail to be on top of the inside fish's tail. From here on, I can't change my mind about that. I've also now carved on both sides of each fish, so all I can do now is narrow them. I can't, for instance, carve the outside fish in deeper, since that would cut into the inside fish. Decision, decisions! Carving isn't for the faint at heart...and then there's all that blood when you have those little slips!





Notice in this series how much deeper all the gaps are becoming. I'm adding in smaller rocks between the larger masses, so I don't carve the gaps out so large smaller rocks can't go in between. Now is probably a good time to illustrate how you make deeper and narrowing cuts with ball burrs.



Carving a deep and narrowing groove is carved with a progression of smaller and smaller burs, each carving the groove more deeply, but never so deep the burr carves into the surface you wish to leave. This leaves a surface that is grooved longitudinally along the cut, and you go back and remove the ridges left, until the surface is nearly smooth. At that point, you are ready to refine the surface with hand tools or long and narrow diamond burs.





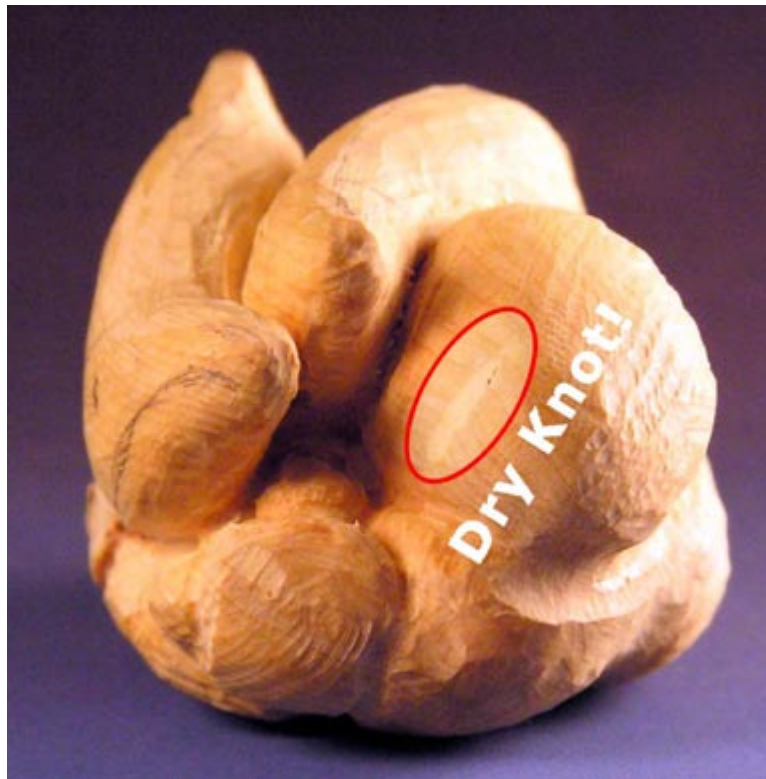

Notice in this series I've run into a small problem in the form of a dry knot. I'm fortunate that it is in the end of the large boulder, and I can deal with it simply by altering the design, changing the shape of the boulder and carving the knot away. If this had been in a critical area, I would have to deal with it either by A) living with the problem, B) filling the hole with a peg of the same type of wood (noticeable), C) filling it with superglue and sawdust (OK if you're not going to color or stain later), D) changing the design and adding an inlay (which may result in your having to add other inlays, or E) tossing it out and starting over again. If you're a beginner, keep carving for the learning experience. Knots like this are not uncommon

in boxwood, and you can't necessarily know when they'll show up. The surface may be fine, with a nasty surprise waiting below. Here, I was lucky that the knot was both in a non-critical place and wasn't either a loose knot (where the knot can fall out) or a nasty little pocket of bark or rot.



The above illustrates how deep I'm carving. The image on the left is when I began carving this morning, and the image on the right is where I left off after another full day of carving. Note how the small boulder is becoming more defined, and the area between the fish is being excavated quite deeply. I'm planning eventually to completely tunnel under the left fish into this area. It will probably become part of a "natural" himotoshi.



These are the additional burrs I used, as well as the two larger ball and flame burrs from the first part of this tutorial.

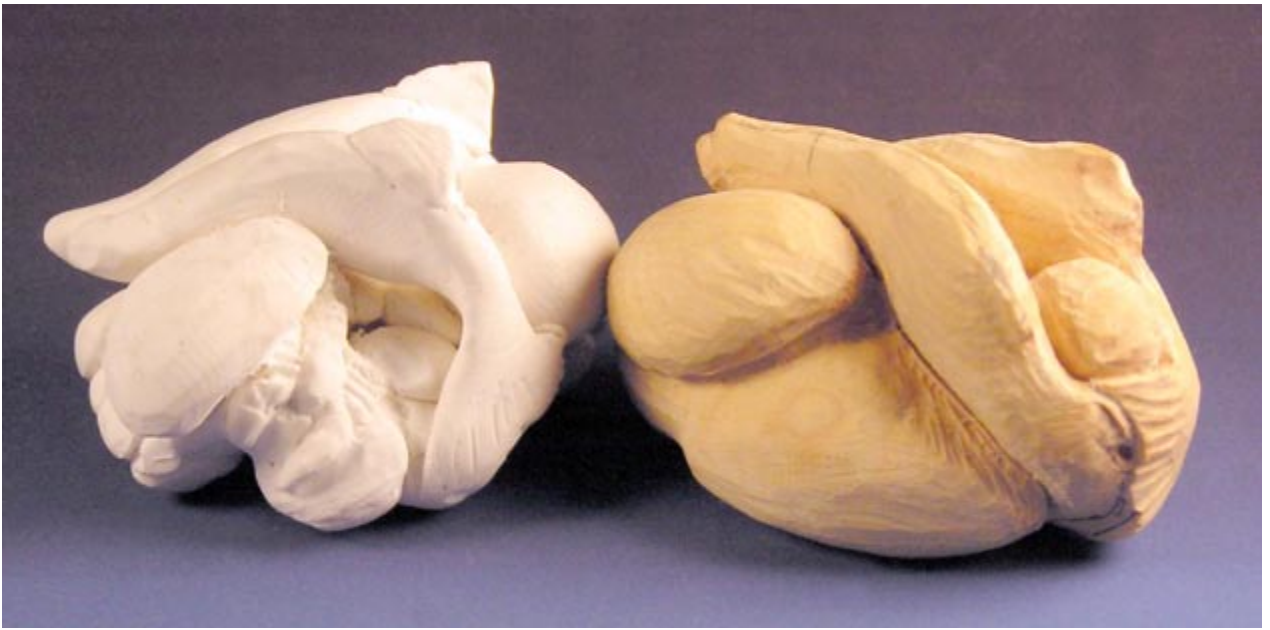

This is probably a good time to start adding the crayfish, since I'm at a reasonable stage to do so, and I'm in the mood for crayfish. I need to watch when I add delicate portions of the carving, since there are times I'm pressing fairly hard with my tools and burrs, and should delicate parts get trapped between the pressure and a hard surface, they might break off. I've carefully considered where the delicate crayfish will go so it is protected by more sturdy elements of the composition, in this case the rocks and thicker fish. In this little nook, damage can only be the result of an unlikely accident or deliberate misfortune, not casual handling. In the above image, I've smoothed the area where the crayfish will go, so I can draw (using a pencil, not pen!) the crayfish in. Below, I've drawn in the crayfish.





Above, I've begun roughing in the major shapes and planes just using a small ball burr. I've carved very deeply around the claws, since I want them to sort of hang down (almost dangling) in front of the crayfish and be in close contact with the small rock that will go in below them, for support. I'm looking for radical differences in the planes the various elements of the crayfish occupy, to avoid a "flat" appearance. I'm planning on the left set of legs to be fairly flat (just in relief) against the underlying rock (for security reasons) and will carve the right hand set crammed in against the rock, but much more three dimensional (maybe even completely undercut below) since the adjacent rock will protect the tiny legs.



Above, I've rounded off the head and body. I haven't begun any undercutting yet, to leave the option open as the carving progresses to sink the crayfish further down into the wood, if necessary.



Here are a few detail views from other angles.



Here I've added in the rocks, using a small ball burr. I've established where the rocks are, and rounded them all off. I'm not working in the immediate vicinity of the fish or the crayfish yet.



I've deepened the crevices between the rocks with a smaller ball burr, concentrating especially in the triangles where three rocks meet. The burr I've used is the second from the smallest in my burr "palette."





In the above group of images, I've used the very smallest ball burr I have, a 9/0 size, which is just slightly larger than a hair. Notice how deeply I've gone in between the rocks, and especially deeply in the triangle where three rocks meet. I'm looking for deep shadows in these areas. Since boxwood is a fairly uniform color, shadows are very important to separate composition elements.



In this series, I've used a tiny, tapered diamond burr to sand most of the rocks. When I was satisfied with

their shape and smoothness, I used a coarse ScotchBrite™ brand polyester abrasive pad in a mandrel to smooth the rocks even more. Following that, I've wet the surface with water to raise the grain, then polished with a finer grade ScotchBrite™ polyester pad in a mandrel. You can still see a lot of bumpy areas between the rocks that need to be taken care of. Below is an image of the burrs I used for the rocks. From here on out, most of the remaining work on the rocks will be with hand tools.

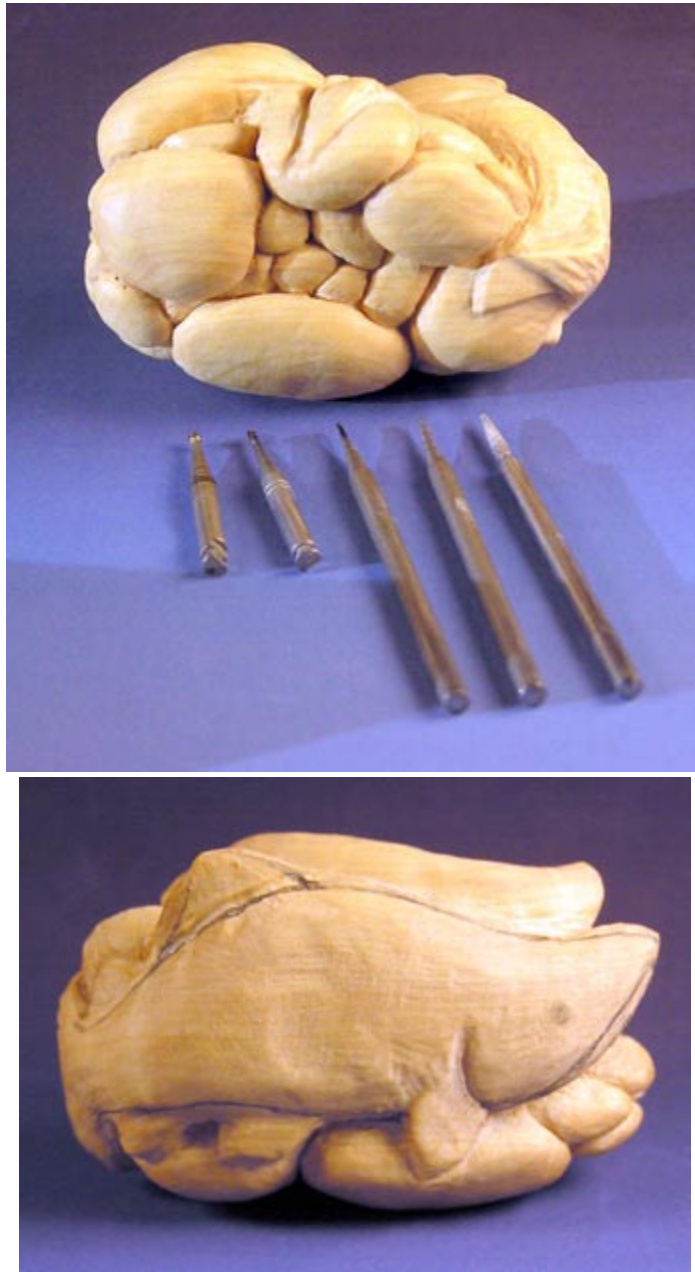

I've drawn in the outline of the outside fish. It needs quite a bit of refining, and it's important to get it right, since it is the one that will be the most visible.



In this series, I've begun cutting the outside fish down to the line, and am excavating between the fish's body and the rocks below and in front. I'm carving quite deeply between the fish and the rocks because I want very deep shadows in these areas.



You can see here in the front that I've carved deeply in between the fish and the rocks, have established the mouth line, and need some significant thinning in the jaw area. I've also started refining the tail and the fins, although the fins are still quite thick. I'm going to need to leave them thick until I have the rocks in their vicinity a little more refined, since I want the delicate fins to remain attached to the protective mass of the rocks. I'll sink the fins further back (except the dorsal - top - fin) once the rocks are at final size.



I've carved further down between the two fish, and excavated under the inside fish. You can see a little light through the hole. I'll make this area the himotoshi (the cord holes).



I've also carved way in behind the outside fish in the tail area. Those deep holes in front of the tail go all the way through, and I'm refining the left (inside) part of the fish shape down deep in those holes, so the fish actually looks disconnected from the rest of the netsuke. Doing this in several areas so you can see light through the netsuke really makes it interesting to view up close.



This series of images shows the continuation of refining the fish shapes, especially the center fish, their fins and tails. It's almost time to rough out the crayfish, start adding the eyes and begin carving with hand tools.



I've continued refining any shape that doesn't look right. I've used a piece of folded 150-grit sandpaper to smooth the large surface planes of both fish, followed by 300-grit. In this series of images I am using my small hook-shaped scraper to shave small, paper-thin shavings off the surfaces of both fish. The sandpaper gave me a reasonably flat and smooth surface, and the scraper is adding to that. Be sure to use the scraper tool WITH the direction of the grain of the wood, not against it.



Here, I've begun roughing in the crayfish. I've used my second-smallest burr (a 4/0 steel ball burr) and begun defining the major shapes, legs and claws of the crayfish.



Now that the major parts are roughed in, I've carved the basic indentations of the "face" and carved (not drilled) the holes where I'll insert the eye pegs. Here's a reference photo to see where we're going.

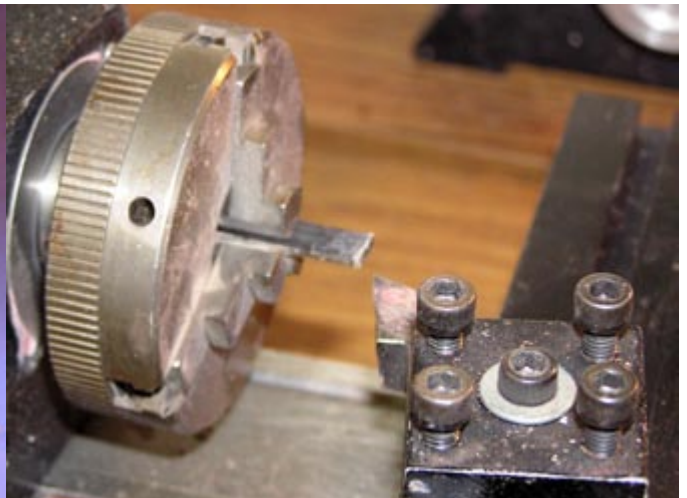



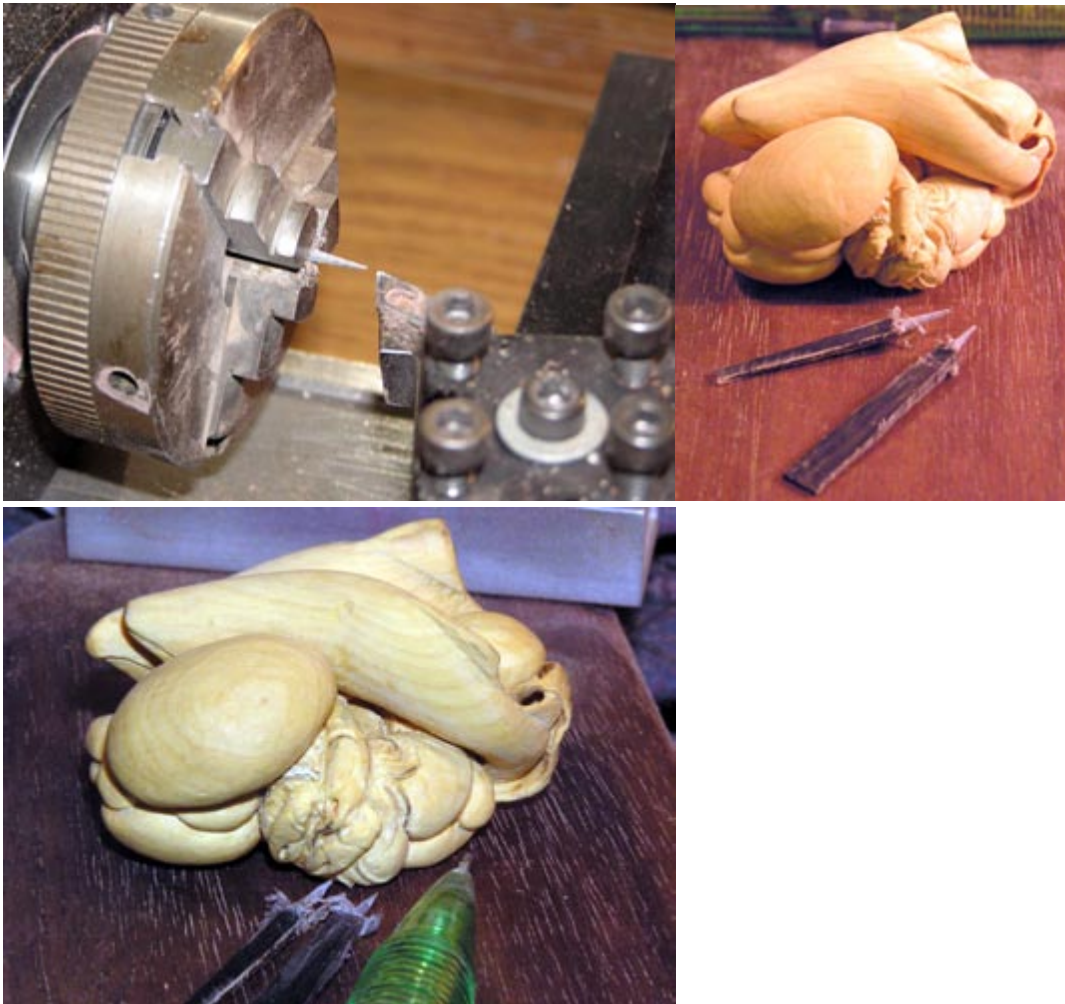

I'm going to use tiny, tapered pegs of black horn for the eyes. Horn is very strong if the fibers are oriented along the axis of the part, and it is slightly flexible, so it can absorb a bit of punishment. In this sequence, you can see the two small slabs of black cow horn. I've used my small Sherline metal cutting lathe to turn the little tapered pegs. Just to give you a hint of the size of the eyes, that's a .5mm lead pencil in the last image.



No, this isn't some weird form of animal torture. I've glued the pegs into the carved eye holes, then used a small burr to cut them off to length when the glue has dried.





I've used small steel and tiny diamond burrs to carve the eyes to shape, and then polished them with a small fiber brush and white jeweler's rouge mounted in my hand grinder. You can see the polished wood area around the eyes.





In this sequence, I've continued carving to refine the shapes and add detail. In the above image are the four burrs I used. The two on the left are 4/0 and 8/0 steel ball burrs for carving, and the two on the right include my smallest fine diamond ball burr and a tapered diamond burr, both for sanding and fine carving.



Meet Tad the Crawdad, ready for final detailing with small hand tools.



I've carved (not drilled) the hole for the outside fish eye. In the first image you can see the four burrs I used for this, in graduated sizes. The three on the left are steel ball burrs in very small sizes, and the right hand is a diamond ball burr. I used the diamond burr only because it happens to be the right size for this particular carving. The second image shows the blanks of fossil ivory and black horn I'm going to use for the eyes. The fossil ivory will be the whites of the eye and the horn will be the dark pupils. The third image is a close up of a real sockeye's eye.

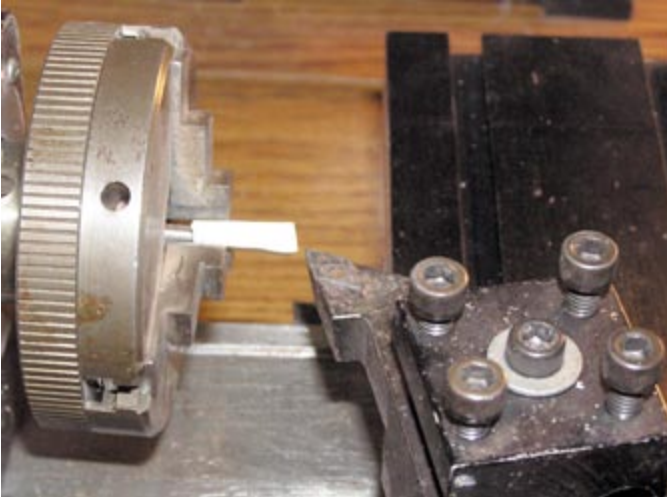

The first image shows a fossil ivory blank in the three-jaw chuck on my Sherline metal cutting lathe, and the second shows the completed tapered peg.

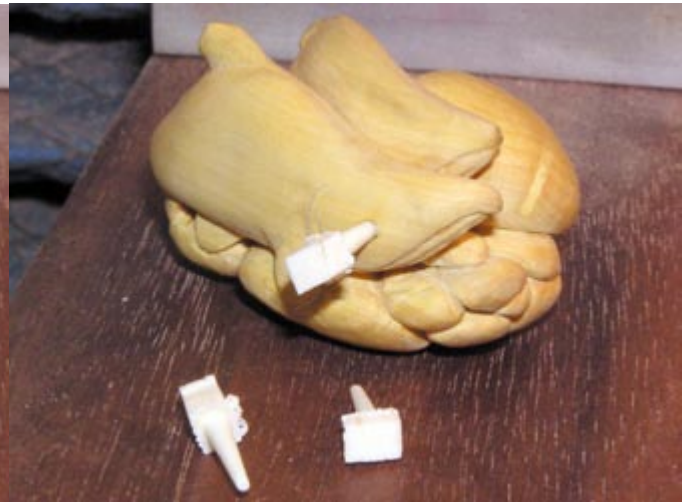

Here are the finished tapered fossil ivory pegs, ready to be glued into the eye socket. The second image shows the peg glued in and ready to be trimmed off.



Now the glue has dried, I cut the excess peg free of the netsuke. You can see the remaining peg lying on the carving surface. I used a small ball burr and simply carved right through the peg, leaving a little standing proud of the surface. The second image shows the eye surface carved and smoothed down almost to the end level of the eyeball. I've left it just a tiny bit high so I'll have enough room to smooth off both the whites and the pupil once it is installed. You can see the tools I used, a small diamond burr for sanding and the tip of my triangular scraper smoothing around the edges of the eyeball and removing any excess glue on the wood. Since I'll be using dye to color the fish, any glue left on the wood will be more than obvious. Get it off now!



Using my two tiniest steel ball burrs and a tapered diamond burr, I carved (not drilled) the hole for the dark cow horn pupil. In the second image, you can see the black horn tapered peg ready to be glued in.



Here's the tapered horn peg glued in, and then trimmed off, leaving a little extra standing proud. You can see I've actually used very little of the tiny horn peg. Be sure and save these little offcuts (I keep them in an old pill bottle) for other projects.



Here's the finished eye, cut down and smoothed to the final shape and size. I've used the tip of a scalpel blade to put a little tiny drop of linseed oil on the surface of the eye, being careful not to get any on the wood. I don't want to interfere with the ability of the wood to take up the dye later on, but would like a little oil in and on the eye to prevent any dye from staining the porous fossil ivory.



And here are the finished eyes in both fish. That's a big chore taken care of. Eyes are extremely fiddly things to do, but as the saying goes, the eyes are the windows of the soul. This is always a major turning point in my carvings and the fish are beginning to have some personality.





Time for another extremely fiddly task, but the effect is well worth the effort. We're going to add some salmon eggs among the rocks at the bottom of the stream. I'll be using pink and red coral to make the eggs. I purchased one of the commonly available small necklaces strung with bits of pink coral branches. These are inexpensive and one will provide a lifetime's worth of salmon eggs for netsuke. I looked for red branches, but could only come up with smaller bits on a similar necklace. In this series of images you can see the raw materials, and a few branches I've selected. Note there is already one egg glued into the bottom of the netsuke.



The longer pink coral branches are easy to hold while forming the egg and post shapes we need, but holding the shorter red branches is a problem. I've solved that problem by using thick, gap filling cyanoacrylate ("super") glue to fasten the short branch to a toothpick, and then lashing the entire assembly with artificial sinew, as in the first image. Artificial sinew adds the additional strength we'll need during carving, and is a wonderful material for temporary fastenings like this. Artificial sinew comes in a roll made of many microscopic nylon strands arranged in a flat waxed strip, about an eighth of an inch wide. I then split a

strip (about three feet long) lengthwise into four smaller strips. You can simply separate each strip in the middle with your fingernail and pull apart. Split each of these again for four total long strips. Each strip is fairly thin, slightly stretchy and the wax makes it "grabby." I use these for holding two parts together while gluing, as well. I like them better than rubber bands.

In the second set of images on the previous page, you can see a small scrap of boxwood that has several holes in it. These holes are the size I will use in the netsuke to glue in the egg posts, and I use this block for test fitting and temporary storage of the eggs (a word to the wise - they are easily lost!). You can see one egg in a hole, two empty holes, a free red coral egg, a pink coral branch with an egg ready to be cut free, and a toothpick with a carved red coral egg glued on. You can also see a hole carved in the netsuke for the next egg.

Incidentally, I carve coral and shell wearing a respirator and in front of my dust collector. Coral dust is very bad for your lungs - protect yourself!

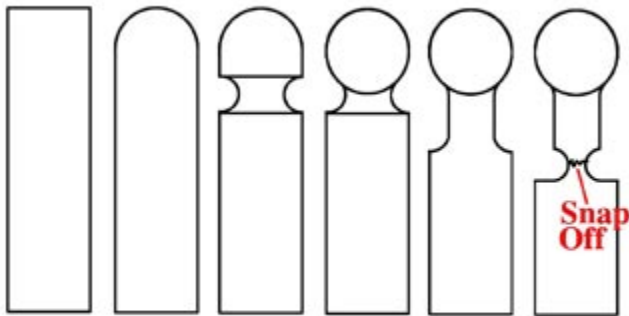

**Salmon Egg Carving Procedure**

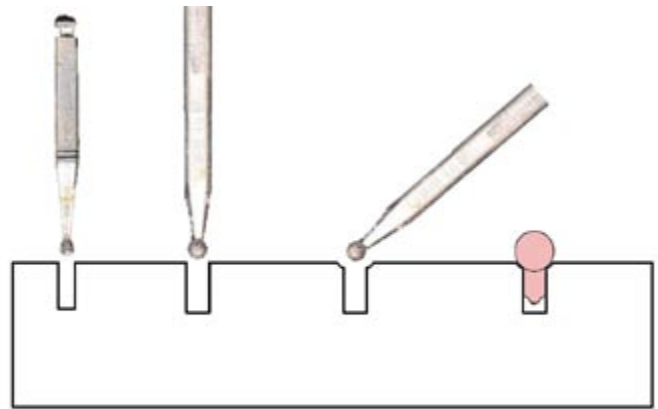

**Salmon Egg Hole Procedure**

To carve the eggs, I use a tapered diamond burr in my hand grinder, and begin by forming a dome at the end of the branch. This will become the top of the egg. Once the dome is formed, I cut in a shoulder below the mass of the egg, and then round in the underside of the egg. Carving on down, I form a small post that I will glue into a hole in the netsuke. When all is ready, I cut in another shoulder at the base of the egg post, and snap the egg free. I carved these particular holes with a small carbide ball burr and a diamond ball burr that happened to be the right size. For the holes in the netsuke, I carve them in, and then cut a slight chamfer around the edge of the hole so the bottom round surface of the egg will fit snugly against the surface of the netsuke.



Here in the first image, you can see the second egg glued in. I use hide glue or epoxy for this, being careful to clean up any glue residue as I glue in the eggs. A little clean up now will help make things a lot easier in future finishing. Obviously, the surface in the area to be glued should be in it's final form, including any color or dye to be added. Glue will cause light spots in the wood if any coloring is added afterwards. I use a small wire tool to place glue in the hole. Use good gluing technique here or you'll regret it later. Glue should be applied to each of the mating surfaces, and the posts should have a fairly close fit in the holes. I've also been very careful to place the eggs in an area where other elements of the carving will protect them from an accidental bump. In this case, the surrounding large rocks keep the eggs from making contact with the surface the netsuke will be sitting on. The eggs are fairly sturdy, so handling shouldn't do any damage, but dropping them or hitting them on a hard surface isn't a good idea. In the second image, I've glued in eight of the eggs. You can also see the three burs I used for both carving the eggs and their holes - one carbide ball burr (holes), one diamond ball burr (holes) and one tapered diamond burr (eggs). Only a few more to go! Light is beginning to show at the end of this tunnel...



Here are all the eggs in place and polished with a white jeweler's rouge. Now to put in the fin textures and go over the whole piece to take care of any and all little problems.



Here, I've used small diamond ball burrs and a small tapered diamond burr to cut in the fin rays. The crayfish legs have been thinned down as much as I dare. I could have pierced them through on the underside, but they look fine to the naked eye, and piercing them would have weakened them greatly. Netsuke are meant to be handled, and broken legs are not a desirable end product! I've also gone over everything with fine sandpapers and abrasive polyester pads, as well as polished the broad wood surfaces with white jeweler's rouge on a small hard felt buff. The sockeyes are ready for their Procion™ dye applications.

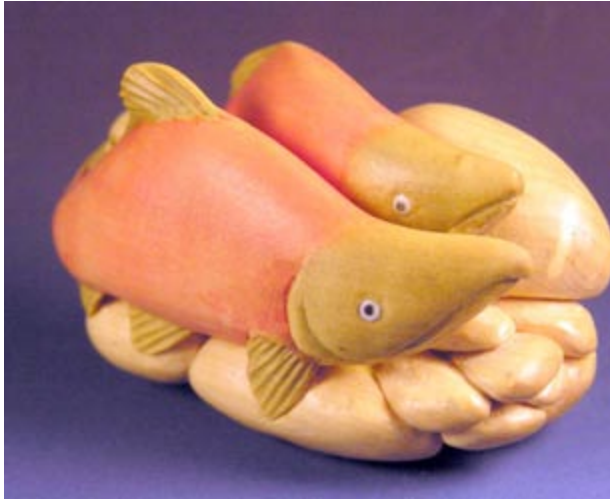



Here is the completed netsuke, ready for the first application of a linseed oil finish. The oil will add a lot of depth to the wood, bring out the grain (and any little flaws!) and darken everything slightly. There will be several rounds of oil, polish, tiny nook and cranny cleanups, repeat, repeat, repeat, repeat, repeat, repeat, until I'm finally satisfied.







My client has asked for a few changes in the final design, which includes changing the ivory and horn eyes to amber inlays. I've opted to use the trick eyes which seem to follow the viewer around the room.





Here are the raw materials for this style of eye. The large piece of amber in the rear of the image is in the raw state. The middle ground is a smaller piece removed with a bandsaw, and the foreground is a smaller peg, cut in the same manner. I'll chuck it in the lathe to turn the tapered peg, just like the ivory and horn eyes I carved earlier. The paper has a small section of 24-carat gold leaf. You can see the amber has a nice golden color in the large piece in the background, but most clear amber I've seen is almost colorless in the small sizes we need for netsuke eyes. The gold leaf will provide both the color and the light reflection we need for great-looking eyes.

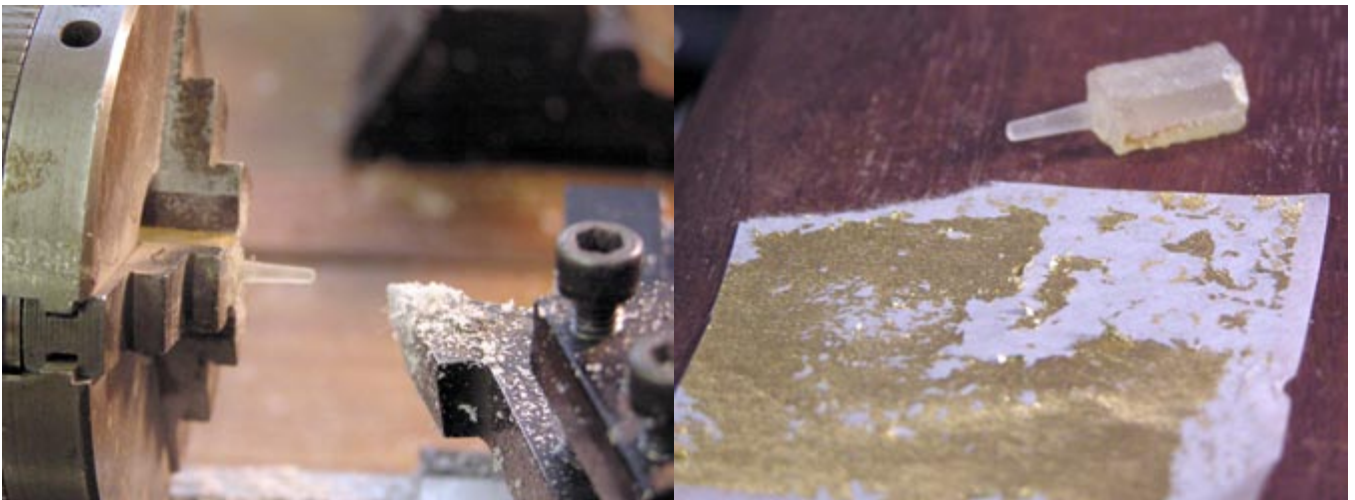

Here's the amber peg in the lathe, and removed from the three jawed chuck. Be careful clamping amber, since it is very brittle and breaks quite easily. Amber eyes are not robust, and break and scratch easily.

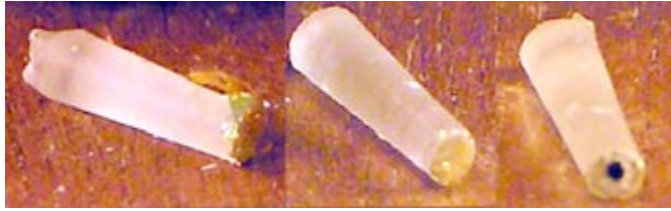

Here are the steps in making the eyes. I've very carefully fit the peg into the eye socket. I want a close fit, but not a tight one. A tight fit is begging for problems. As the wood moves over time with changing humidity conditions, the amber will crack if there is any stress. I want enough room to allow for wood movement, but not so much slop there is a readily noticeable gap. I want a small layer of cushioning glue between the amber and the wood. On the left, I've applied a tiny amount of gold size (the glue used with gold leaf) and pressed the small end of the peg into the gold leaf. The leaf will stick quite readily. I let the size dry for a few minutes and then repeat the size and gold leaf application several more times. I want a nice thick layer of gold on the bottom. You can see the ragged edges of the leaf hanging off. The center peg has been burnished with a hard, round object, and the excess gold removed from around the edges. The right peg shows the pupil, which was created by cutting a small dome in the center of the gold leaf (and into the amber), then filling the small dome (dent?) with sumi ink. Let the ink dry thoroughly and it's ready to inlay.



Here one of the eyes is being glued (using clear epoxy) into the eye socket. When dry, I'll use a small burr to carve off the excess, leaving a slight dome standing proud of the surface. Using tiny scrapers and fine sandpaper I refine the surface. Finally, jeweler's rouge for a spotless polish.



Here are the finished eyes.

### *Inlaying Thin Elements*

I figured out an easy manner of inlaying very thin elements like insect legs. This method uses the grain of the wood to advantage and results in a very strong inlay which projects above the surface of the wood. Here's how to accomplish this feat.



This method uses a thin surface substrate and cuts the channels entirely through the surface. In the above images I've used a forstner bit to drill a flat bottomed hole for a basket lid. The second image shows a thin piece of holly wood turned and slightly domed that will be the substrate for the inlay, a silk weaver spider.

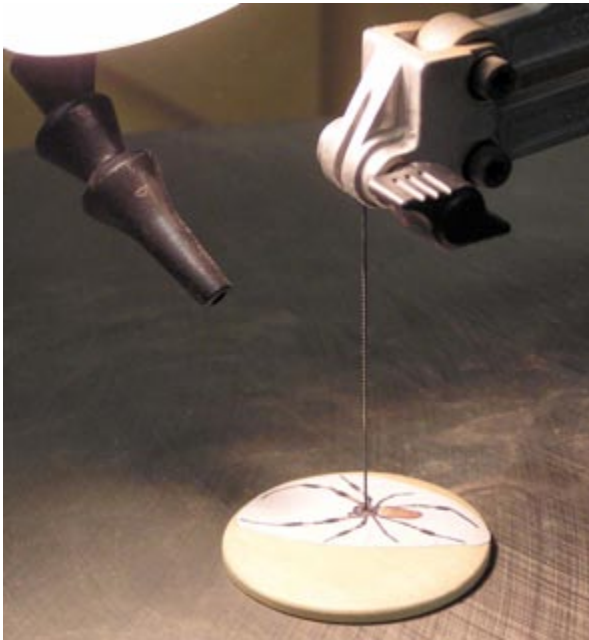

Here I've used robber cement to glue on a paper copy of the spider, scaled and positioned like I want. In the second, third and fourth image I've drilled a small ( $\frac{5}{64}$  inch diameter) hole in the center of the spider's head. This hole is centered in the spot where all the legs converge, and is smaller than the head inlay that I'll eventually put there. It will eventually be covered and filled with the head inlay, but for now I'm using it for the entry hole for my scrollsaw. In the last image you can see the scrollsaw blade threaded through the wood and reattached to the blade holding fixture. From here I'll cut a thin saw kerf down the center of each leg. I'll be paying attention to make the turns of the saw cut at each joint in the spider's legs so everything will be logical and look natural. Remember that scroll saw blades come in different thicknesses, so you can use this to your advantage in inlaying various different sizes of thin elements. I used a 2-0 skip tooth blade for this piece. If you don't have a scrollsaw, a jeweler's hand saw will work just as well.



Here are the saw kerfs, ready to begin the inlay process. I'll be insetting short sections of thin tapered wood in each of the kerfs until the leg is completed.

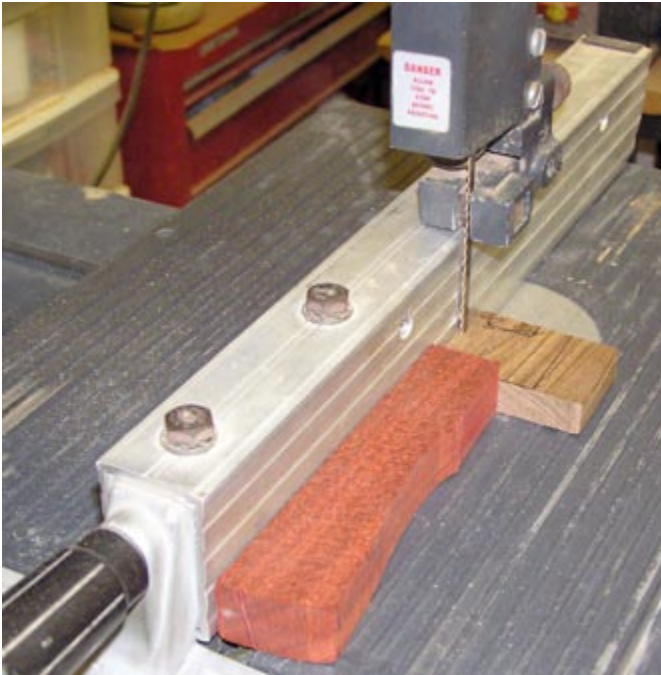

Since we're going to need multiple thin pieces of a darker wood, I've set up the bandsaw with a fence to make this a little easier. The small brown piece of Bolivian rosewood is the piece I'll be cutting the strips from. You can see a strip half cut in the second image. I'm using a piece of scrap wood (the reddish wood) as a push block to keep my fingers clear of the blade. I'm cutting with the grain of the wood to exploit the best strength qualities.

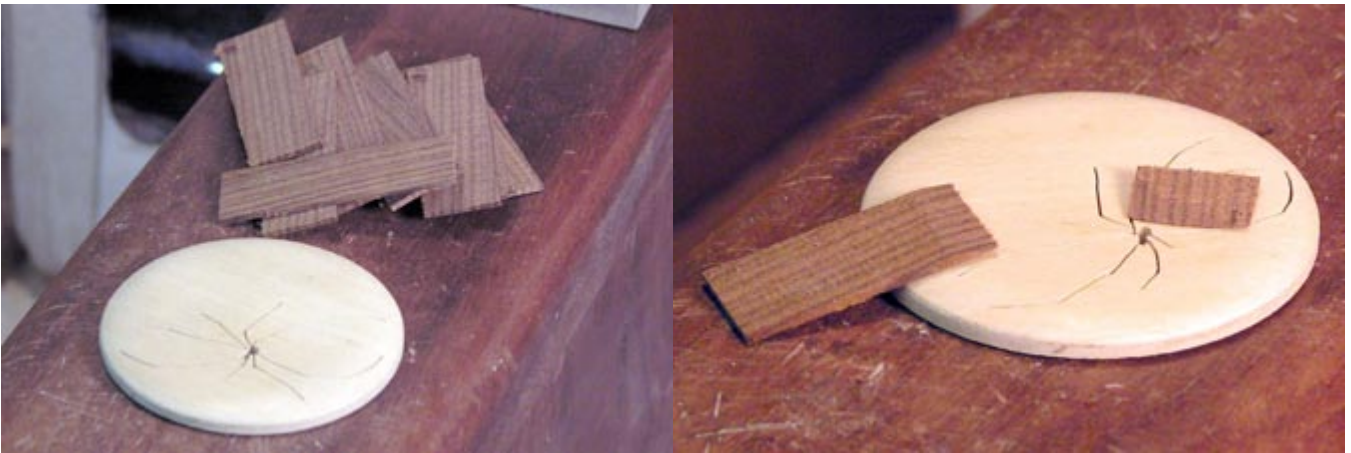

Above are the thin strips of rosewood for the legs. These are less than  $\frac{1}{16}$  of an inch in thickness. In the second image I've sanded a taper on both ends of one of the strips and cut one off. I usually just use a small round burr in my grinder, lay the strip on a waste wood block and carve the ends off.

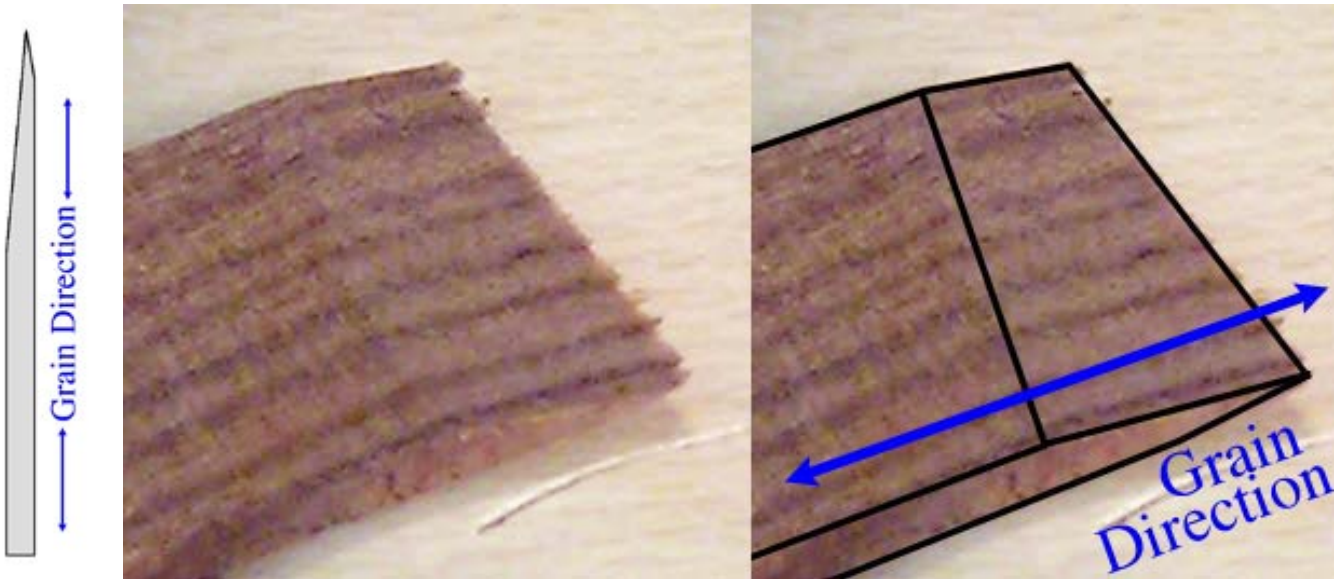

The taper should be very gradual, and the above images illustrate that. The drawing is a side view.

**Very Important! Note the direction of the grain is along the long length of the thin strips. This provides the inlay with strength. Should the grain run any other direction, damage to the inlay will probably result.**

I usually sand a very long taper on one side, and a shorter one on the other, just for ease. Your project might require something different - keep an open mind...

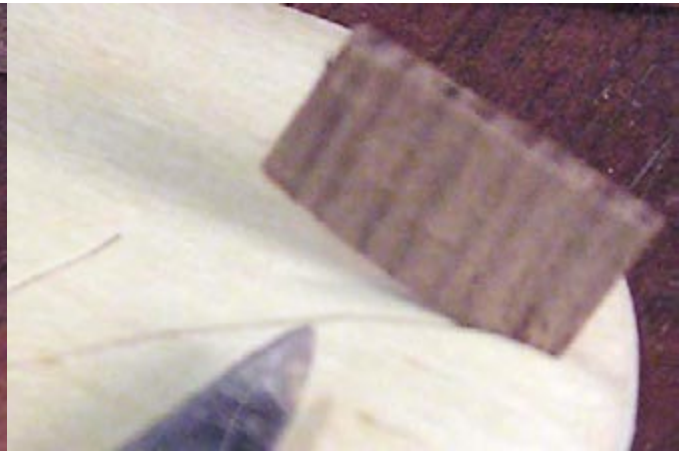
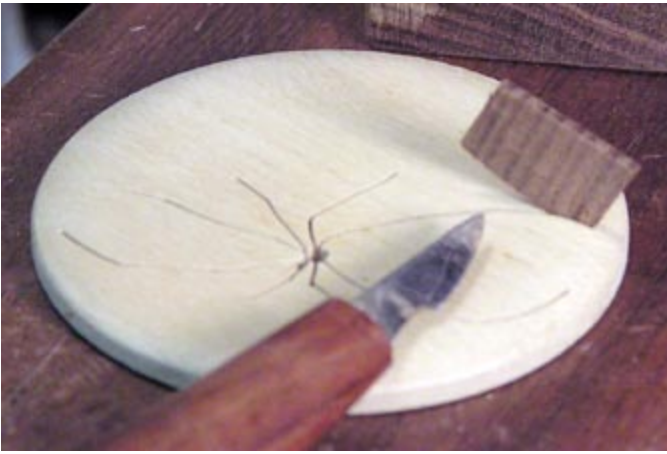

Beginning at the end of one of the legs, I insert the tapered end of one of the strips, making sure to press it firmly against the end of the saw kerf. I've inserted it at an angle, since the spider legs consist of short straight and curved parts of the saw kerf. I'll use the tip of my knife to mark the place where the tapered wood no longer fits, either because of the curve or a turn in the leg.

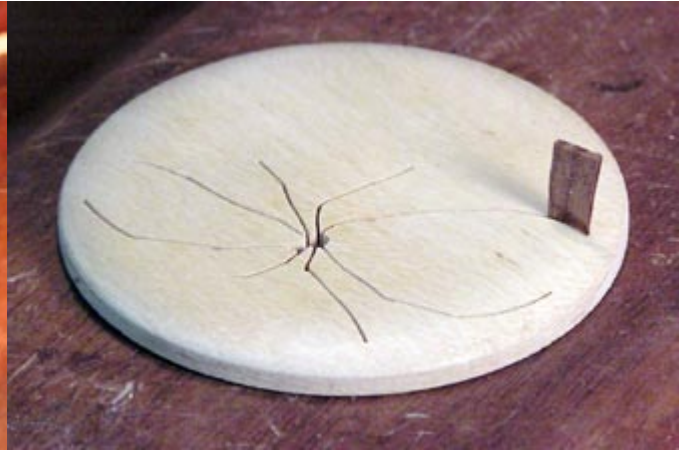

Once I've marked the spot where I'm going to cut to length, I place the tapered wood on a waste wood block, line up my knife and simply press down. Since the grain of the wood is running along the long length of the thin strip (pointing up as it will be inlaid into the saw kerf) the thin strip will simply split along the knife blade. Clean up the split if necessary, and test fit back into the saw kerf. If everything is set, the next step is to glue it in.

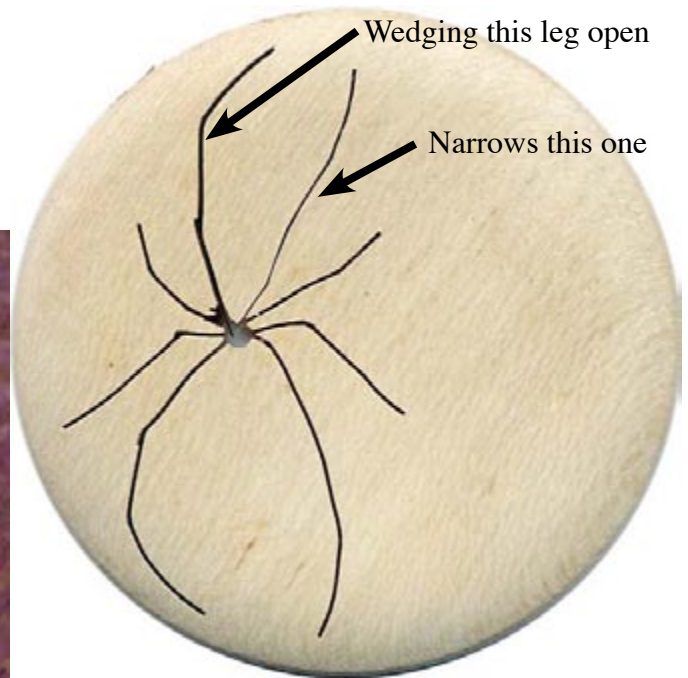
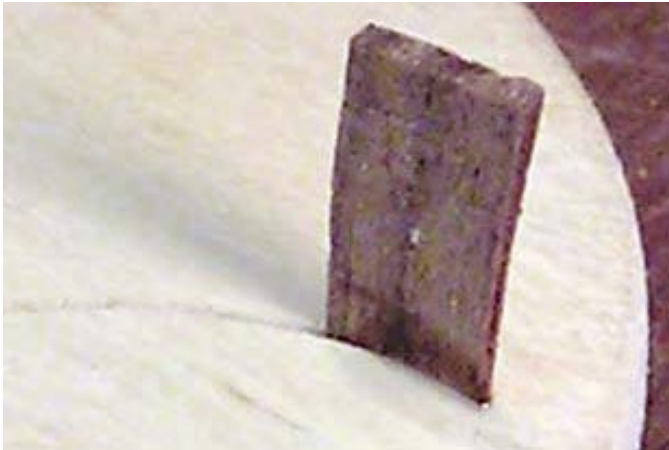

Here's the first piece glued into the saw kerf. There are several things that are critical to remember here. First, use only as much glue as you need, not more. You don't want extra glue puddling up along the inlay - this will make extra cleanup work on the substrate surface. Second, press the tapered piece in only hard enough to seat it well. If you wedge it in too far, you will be forcing the adjacent wood to move over into the next saw kerf, narrowing it. This way, you'll end up with one thick leg, and other leg next to it will be too thin. If this occurs, all is not lost; just put it back in the saw and re-cut the saw kerf.



Here I've glued in another tapered piece, following the same procedures as the first one. Making sure I've firmly seated the right hand end of the second tapered piece against the left hand end of the first, I've measured, marked, cut and glued the second piece in. I've also used a small dot of glue in between the tapered pieces so they've been glued together as well as glued into the saw kerf. While I normally don't like to use alphacyanoacrylate ("super" glue), I make an exception here and use the gap filling type. You can use other types of glue for this if you are willing to slow down the process; I use the instant glues for speed.





Here's a whole row of tapered pieces glued into the saw kerf. Notice on the last tapered insert I extend it into the hole where the legs converge (the one I used for the saw blade). I'll trim the ends flush in the hole so everything ends up nice and neat, as I'm going to use this hole later when I inlay the head portion of the body. You can also see the brand of instant glue I like to use. It's not really instant, since it's thick and doesn't dry instantly, but is quick and is compatible with the linseed oil finishes I like to use. I also use a spray accelerator that dries this kind of glue instantly when I've inlaid all the tapered pieces in a leg, AFTER I've cleaned up any puddling glue along the surface and inlaid tapered pieces. I really like my little leaf shaped scraper to remove any glue puddles in the corners before they've completely hardened.

**NOTE! Using an accelerator with instant glues will often leave a glaringly white residue on the surface of any exposed glue. Make sure you clean off any excess glue on surfaces that you aren't going to carve away, or you'll have an unpleasant little surprise to fix.**

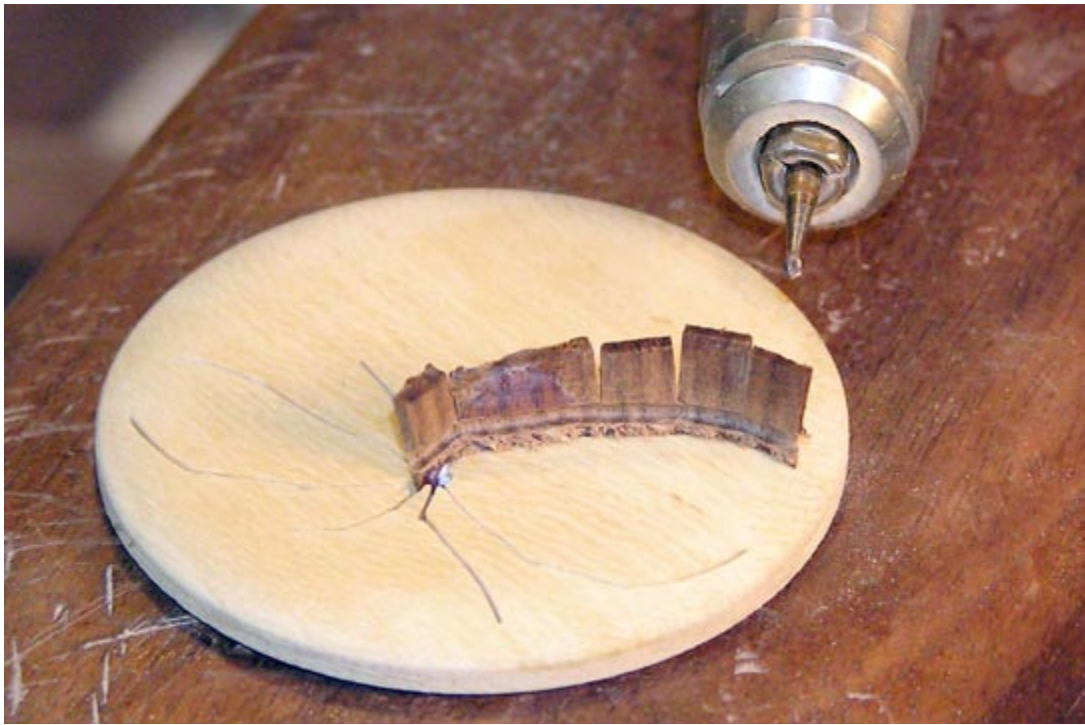

Once the entire leg has been inlaid and the glue is dry, I've begun to trim the entire leg to size and shape. Here, I've used a small round dental burr to carve a groove down one side of the tapered pieces, carving a little higher than I intend the final size to be. I'll continue to deepen this groove until I've cut all the way through.



Here the excess has been cut away, and I've tapered the leg towards the end and also rounded the sides somewhat.



Here I've used a ScotchBrite™ polyester pad to finish the job of rounding, sanding and smoothing the leg. Go gently here, since this coarse pad can damage the holly substrate surface and erase the leg very quickly. I'll use this for each leg as I get them finished.

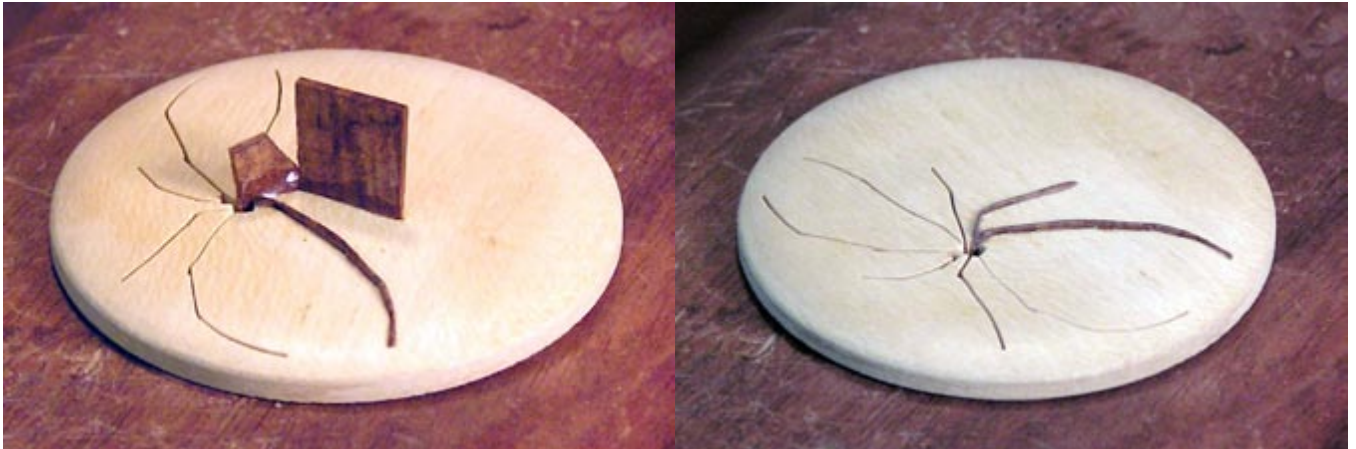

In the first image, I've begun inlaying the tapered pieces in the next leg. I lucked out on this one since there turned out to be a relatively long straight run, hence the large first piece. The second image shows the finished leg.



Here are four of the legs finished on one side.



Here, I've finished all of the legs.



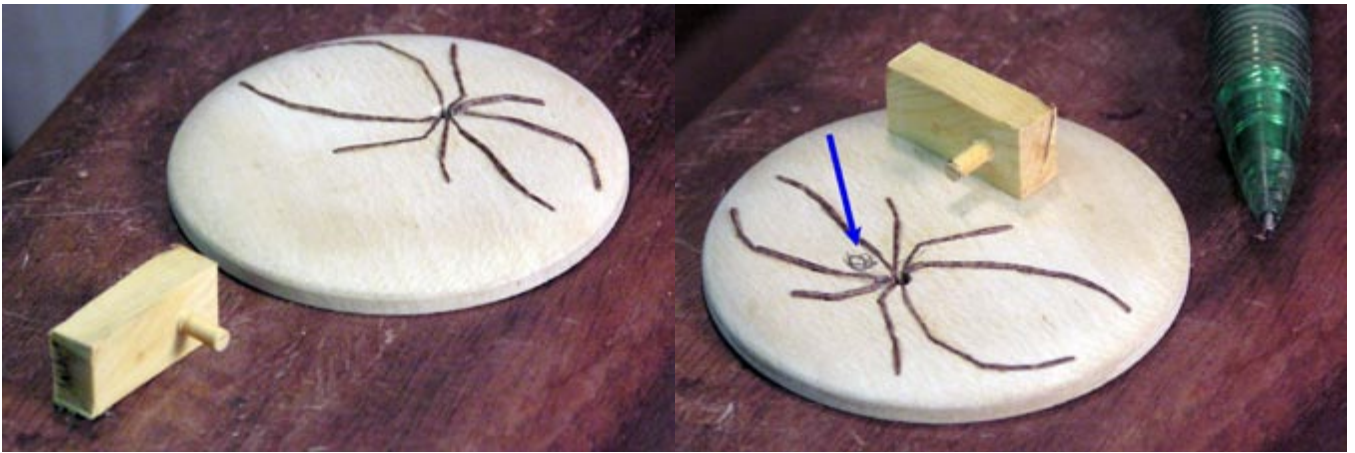

Now I'm ready to begin inlaying the abdomen. I've turned a small peg on the bottom of a piece of very yellow boxwood (chosen strictly for it's color). In the second image, I've used a sharp pencil to mark where I'm going to carve (not drill!) a hole for the peg to fit in. I insist on pegs for this type of carving because I want the carving to have an unusual amount of strength - I expect it to be handled often, and I don't want it damaged. You may have noticed I've been being a bug here on the issue of strength...

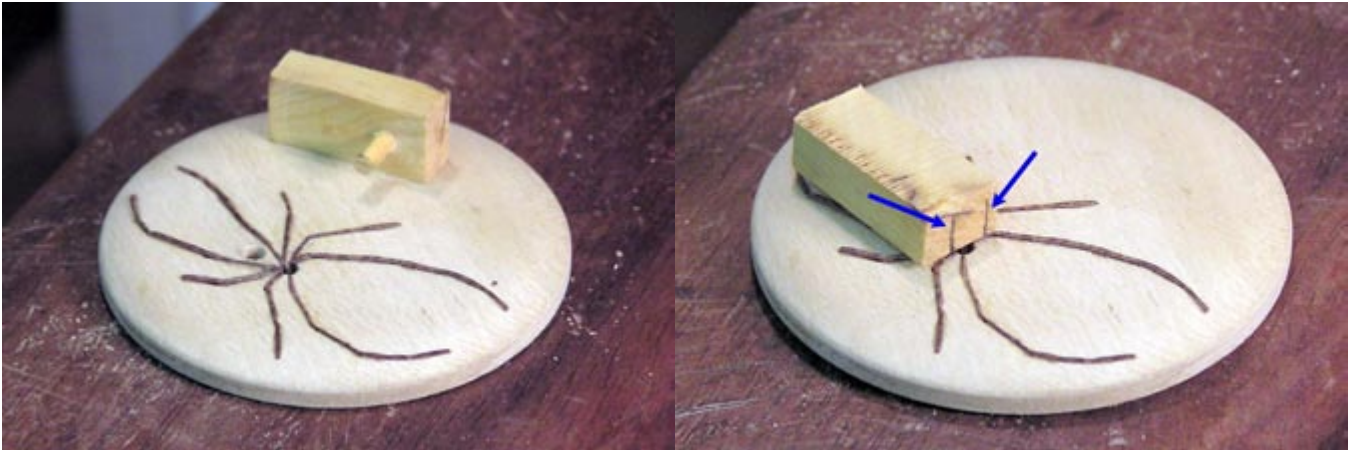

In the first image you can see the hole I carved, using smaller, then larger round burs until the peg fit well. No sloppily large holes here - the peg is for strength, and won't hold well if the hole isn't tight fitting. In the second image, I've set the peg in the hole, aligned the block and marked the width of the body with my pencil.



Using those marks as a guide, I've drawn in the approximate body shape on the block. In the second image, I've carved the block roughly to that shape. You can see a copy of the pattern I used. I print several of these, scaled to size, on a sheet of paper so I can have extras as I need them. I find they are handy cut out like this, since I can fold the pattern in different places and hold it next to the carving to compare sizes. For instance, to compare the length of the abdomen we're carving now, I would fold the paper down the center of the body longitudinally.



In the first image, I've placed the rough carved abdomen in the hole. You can see that it is sitting on top of the legs, and not contacting the holly substrate surface like I need it to when it will be glued. In the second image, I've begun to correct that using a piece of carbon paper to mark the areas where I need to carve away so the legs will fit into the abdomen block. If you look closely, you can see some of the carbon marks on the bottom of the block.



In the first image is the second go round with the carbon paper. I'll mark, carve away and repeat until I'm satisfied with the fit. In the second image is the finished block, ready for gluing.

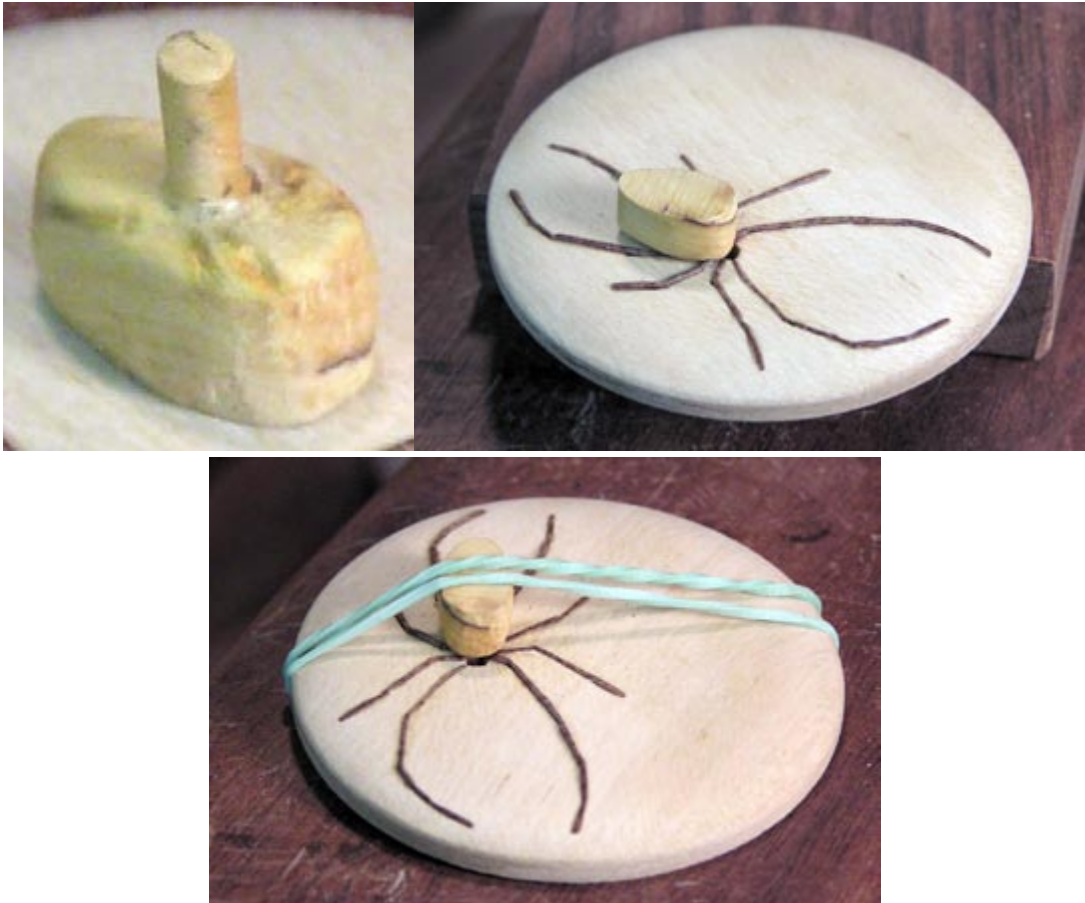

Here's a close-up of the finished block, in place ready for gluing, and while gluing using a rubber band to hold it securely until the glue dries. I've used a standard carpenter's wood glue for this, rather than the instant glue.



In the first image, I've continued carving the abdomen until it's roughly at its final shape and size. I waited until the abdomen was glued in to carve it to shape because it is a very small part and is much more easily held this way. You can see the front end of the abdomen extends partially over the original saw blade hole. Nearby is a tapered peg I turned for the head portion of the body. In the second image, I've carved a hole angling back into both the abdomen and the holly substrate disk.



In these images, note how the peg fits into the hole, but has gaps below the shoulders of the peg. I'll have to carve away portions of the shoulders to get it to fit against the holly substrate disk.



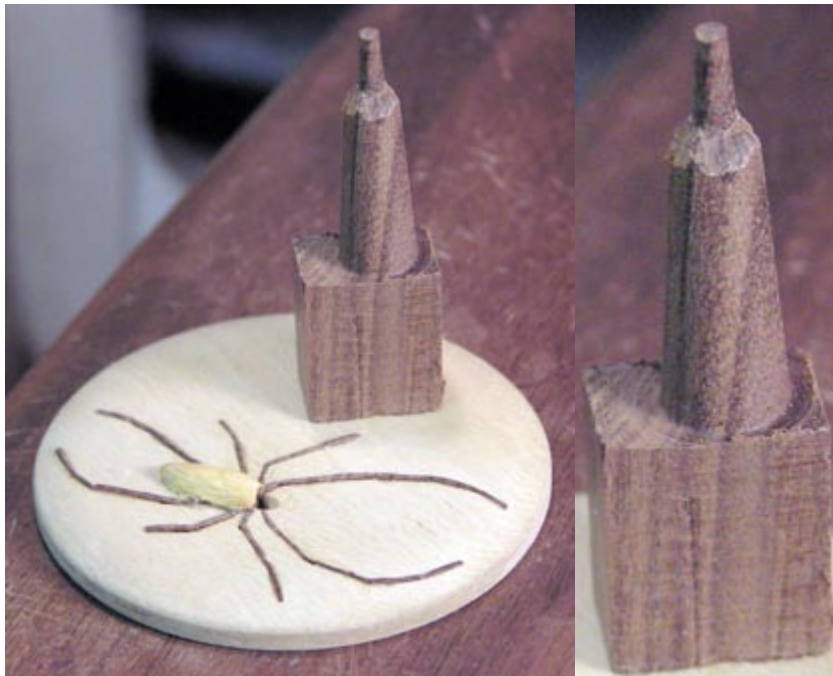

Here I've used the carbon paper trick to carve away the shoulders so the bottom angle will fit against the holly disk substrate for additional strength when glued.



In the first image is the peg glued in, a much better fit. The second image shows the peg cut off, ready to carve the head portion. Below is a close-up of the fit.





Here's the head, carved to shape.



I couldn't leave well enough alone, so I had to add some eyes. The first image shows several tiny fossil ivory pegs glued into place, and the second image shows the trimmed and final-carved. I went with white eyes as a contrast to the dark wood head, even though the real eyes would be dark. Artistic license, you know...



Here I've used a knife-tipped woodburner to LIGHTLY burn in a spider web.



In these images, I've used a specially created tool to place tiny dimples along the sides of the spider's abdomen. See the section on **Small Raised Dimples (Lizard Scales)** to see how to make this tool.



Here's a close-up of the dimples.



Using my altered fine-point burner tip (see the **Burnt Offerings: Pyrography and Small Carvings** section for more about this burner tip), I created a little texture among the dimples.

To add additional strength to the carving I'll force epoxy glue into the saw kerfs on the underside when I glue the holly disk into the basket lid.



Here's what I started with. In the first image, I scanned in the holly disk and Bolivian rosewood lid, then superimposed and scaled my spider pattern to determine size and placement. The second image is the pattern sheet I printed out for use during carving.



The first image shows the holly disk epoxied into the teak lid. In the second image, the assembled lid is shown in the turned and drilled walnut rim.

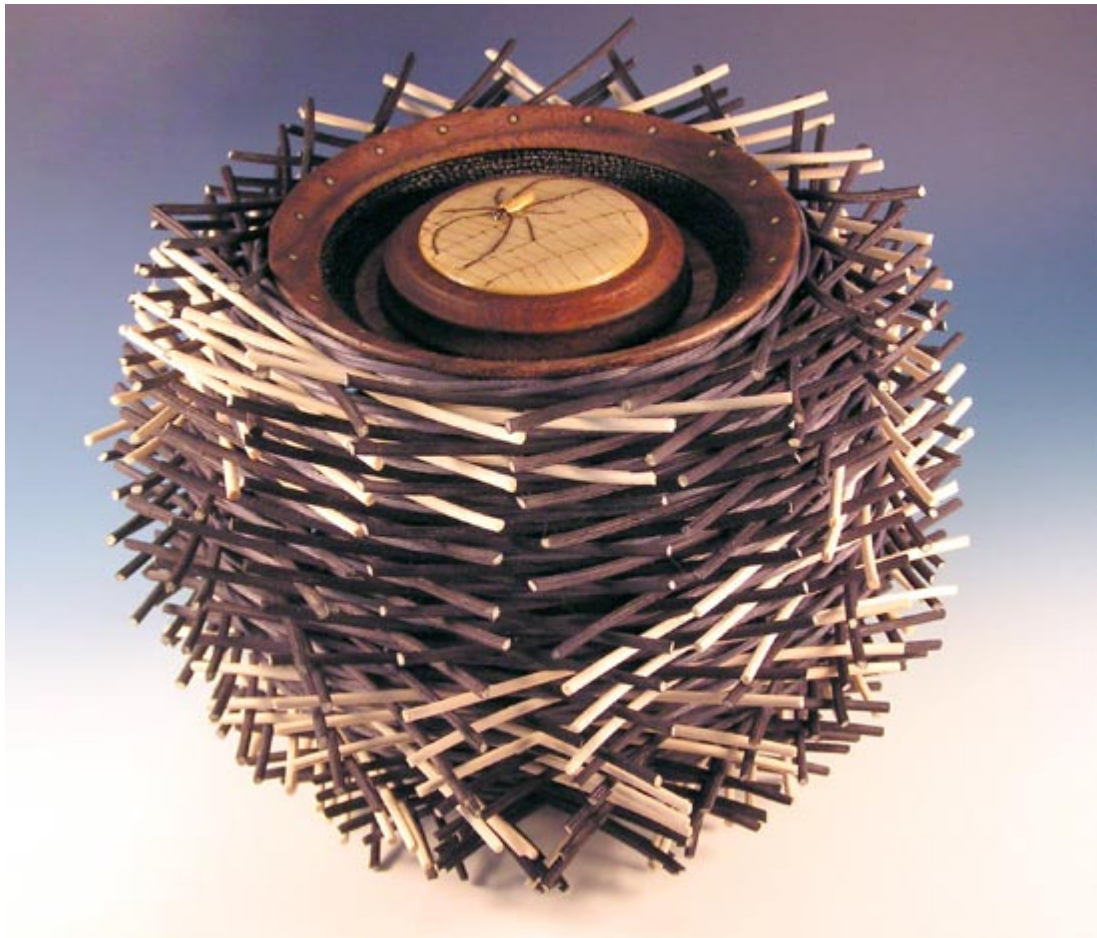

Here's the finished art basket, about 8 inches tall. My wife does the basket weaving. We call these "Sea Urchin" baskets, since we live on the Pacific coast. I guess they would be "Porcupine Baskets" if we lived in the interior of the country...



Here are a few more inlaid insects using this technique, this time a little folding knife. The firefly is deer antler with inlaid ebony legs, and the spider is all ebony.

### ***Errors and Common Mistakes***

#### **Filling holes and correcting errors**

It will happen. You will slip or mistakenly remove something you should not have. When carving natural materials, you can always run across unexpected areas of rotted wood, knots, or unpleasant whatever. Carving a netsuke is always a learning experience. You will have to adjust your composition, fill a hole, or apply another piece. Don't get flustered. If you work diligently, it will probably not be noticeable. Don't give up too early. If you can't figure out what to do immediately, put the carving away for a while. Often, you will figure out what to do in several days or weeks. If not, at least you've had a good learning experience. To fill a hole or glue on an additional part, you must take into account how you intend to finish the piece. Invariably, fillers and glues will not finish the same as the rest of the material, so you must devise a way to make them unnoticed. Textures are a good way of reducing the contrast between the original material and filler or glue lines. You may be forced to finish the piece in natural color when you had originally intended to darken it. The best filler I have found for wood that is going to be finished with a penetrating oil is to mix shavings of the original material with a clear glue. Try not to use sanding dust. Sanding dust invariably contains sandpaper grit that alters the look of the filler and won't match the surrounding wood. I find the alphacyanoacrylate (the instant or "super") glues are good choices for the glue. They dry very quickly, and seem to blend in the best with the oil finished wood. I apply them by taking fine shavings of wood, pulverizing it, and packing it into the void. The fine structured carbide cutters can often provide you with the fine dust needed. Then I add the alphacyanoacrylate glue (the thin kind, not gap-filling), press the material into the void again, then allow it to dry (about ten minutes). I repeat the process until the hole is filled. When cured, the wood/glue mixture will carve about the same as the surrounding wood.

## Common Mistakes by Novice Carvers

One of the most common mistakes by novice carvers is not getting their subjects “round” enough. I see many carvings that could have been dramatically improved had the carver simply taken a little more effort to round off the corners. If you look in one of the woodcarving journals, you won’t have to look far for an example of this. While it takes a lot of effort to properly round off a square block into a face using only hand tools, with a power carving tool there really is no excuse. Give it a little extra effort: you’ll be pleased with the results and impact your carving will have on viewers.

Many times I hear a carver explain that a certain questionable look or portion of a work was included because “that is how the original looked.” Remember that art is not supposed to be an exact science. Art is the process of making something pleasing. It is a process by which you can interpret a subject, rearranging or adding what is needed for good composition or removing items not needed. If you want an exact copy, take a photograph. It will be a much better reproduction than you can possibly achieve by carving.

## Finishes

Once the netsuke is completely carved, it is time to apply the final finish. Items like ivory may need no finish, but may be darkened if desired. Other materials like antler are commonly left natural. Woods may be stained or left natural, but require some sort of protective surface finish to reduce wear, grime accumulation, and the detrimental effects of humidity. I avoid making my finishes too shiny. A nice sheen is good, but excessive shininess isn't. I don’t use lacquers or shellacs. You usually don’t see shiny finishes on professionally-carved contemporary netsuke. Most woodcarvers seem to agree that shiny finishes are not desirable.

## Polishing

I often use a combined product of hard wax and polishing compound called Hut™. This comes as a small brick, and is available from specialty woodworking stores. It leaves a lovely satin shine on the surface, and can remove fine scratches as well. Depending on the wood used, you may use various polishing compounds like white or red jewelers rouge for polishing, either before or after the finish is applied. Be certain to experiment on scraps of the same material you are carving. The colored polishing compound may collect in the large pores of some kinds of wood or antler, and be very difficult to remove.

## Silver Nitrate

While technically not a finish, it is a method of chemically darkening wood. It may be obtained from chemical suppliers or your druggist. It comes as a clear liquid that darkens when exposed to light. I have used it and obtained colors from dark brown to black. One word of caution though; it is mainly a water solution, so it runs if you’re not careful. I would recommend you apply it with an artist’s ink pen (the old-time kind you have to dip in the ink). It works for both ivory and wood, but be sure you put it where you want it. You must shave off surprising amounts of material to get rid of it. When you scrape the area clean, you are often just exposing more of the silver nitrate to light. It initially seems as if you’ve removed it, but in a short time will darken as well.

## **Ivory Finishes**

The ancient netsuke artists seemed to darken their ivory works about half of the time. They most often seemed to apply a “tea” made from birch cones (they look like tiny pine cones) steeped in water. This was applied by letting the ivory piece repeatedly soak in the tea, either cold or warm. In between soakings, the ivory piece was dried and polished. The process was repeated as often as needed to get the ivory to the desired color. In my experience, the warm tea seems to act more quickly. With repeated polishing, the nooks and crannies of the netsuke became darker than the areas more easily reached with the polishing materials. I’ve used tea (like you drink), but didn’t really like the way the ivory took it up. I think I would try some other natural stains if I were to do it again. A nice, dark brown stain may be made by soaking walnut shells or sawdust in water and ammonia (about 50/50). A yellowish stain can be made by soaking old yellow onion skins in the water/ammonia mix. Many other colors can be obtained by soaking sawdust from exotic woods in the water/ammonia mixture, or in alcohol. Experiment.

## **Wood Finishes**

As I’ve said before, I generally don’t stain my wood netsuke, but when I do, I use one of several methods. To darken a light wood, I use a liquid chemical darkener I make myself. It consists of steel wool dissolved in vinegar for several weeks, then filtered to remove the sludge. What you should wind up with is a clear liquid that reacts with tannin in the wood to produce a range of browns to blue to jet blacks. How dark the wood turns depends on the number of coats and strength of the liquid you use, and the amount of tannin in the wood. Boxwood turns about the color of walnut wood, while oak or walnut (with high tannin contents) can turn a shiny blue-black. I often use this liquid to blend in lighter colored woods with darker ones. Recently, I made a series of carvings with blackberries as themes. The leaves and most of the thorny stems were made of walnut, but to gain strength I used boxwood for the long, thin stems that the berries grow on. After I applied several coats of the steel wool/vinegar solution to the boxwood, it was indistinguishable from the walnut, and much stronger. The second method I use to darken a light material like boxwood, but only over the entire piece. Since boxwood has such a tight grain, it takes stains very poorly. In addition, a water-based stain will raise the grain on wood, requiring additional smoothing. If the stain does not penetrate very deeply (as in boxwood), then smoothing will remove most of it. To get the stain to penetrate and eliminate the raised grain effects of water, I use a dark Danish penetrating oil finish and literally boil the netsuke in it.

### **WARNING**

**The oil finish is flammable. Use a double boiler in a well-ventilated area, with fire extinguishing agents immediately available. One of the best is a lid large enough to fit completely over the double boiler to smother any flames.**

**Linseed oil is a primary constituent of most commercial oil finishes. Linseed oil is subject to spontaneous combustion if you leave oily rags lying around. In other words, the oily rags or paper towels can burst into fire all by themselves! Please dispose of them properly. I burn them in a safe manner immediately after use.**

### **WARNING**



This generally takes at least 2 hours for boxwood to absorb enough of the oil finish. Take the netsuke out periodically, dry it off and examine to “see if it’s done yet.”

A few words of caution: if your netsuke is made of several pieces, the heat will probably destroy the glue bonds. Wait to glue the pieces together until at least 72 hours after a boiled oil finish is applied. Also, be sure to roughen the contact surfaces so the glues will achieve good bonding. Even for netsuke that I want left natural, I often use the boiling method with clear oil. I either use clear Danish oil, or linseed oil. If you intend to darken incised lines with ink, wait until the oil finish has been applied and is dry. Otherwise, the ink may run into areas you don’t want darkened when the oil finish is applied. The oil finishes are by far the most attractive I’ve found, giving the wood a beautiful depth and clarity. They really bring out the beauty in the wood grain. Also, don’t be surprised when they darken the wood slightly. If the oil finishes are used on ivory, bone, or antler, they impart an unusual translucency. While not unattractive, it seems to be avoided in the commercial netsuke work I’ve seen; however, keep it in mind as a special effect you may want to use.

We've already talked about using fiber reactive dyes like Procion™ MX. To recap, I use little medicine cups with a knife tip’s worth of dye and a few drops of distilled water. Don’t use tap water, since you may get some unpredictable and unwanted adverse reactions. If you have trouble getting the dye liquid to wet the surface, try adding a little TSP (Trisodium Phosphate). We’re making less than half a milliliter of dye, so don’t go crazy. With the amounts of powder the dye comes in, at this rate one container of powdered dye will last a lifetime.

I'm using a high quality fabric and fiber-reactive dye called Procion™ MX. This dye is available in many colors, is easy to mix and isn't bad about rubbing off on other materials. Other commonly available fabric dyes like Rit™ are easy to obtain and will work, but I've found them to rub off on other materials which come in contact with the dyed surface. My dye palette consists of Dark Brown, Scarlet, Lemon Yellow and Sky Blue Procion™ dye. These four colors, when mixed in differing proportions give me every color I want.

Add dye if you want more saturated color, distilled water if it’s too concentrated. I like to have a scrap of the same material I’m carving to test the dye on. You never know what's going to happen until you test. Even the same types of material from different sources can vary markedly. When all is satisfactory, I use a tiny paint brush to apply the dye with. The one I like best is a 2/0 sable.

**Mini-Project: Practice Cuts** - For this mini-project, we'll explore a few practice cuts and textures with a small cube of boxwood.

1. First, using your power equipment, trim the edges of the cube to relieve their sharpness. Follow this with the coarse polyester pad in a mandrel to smooth all the surfaces and edges.

**Note: Remember to keep good hold of the small cube, or the power tool will take it out of your hand and throw it into the largest pile of sawdust or most inaccessible place in your studio.**

2. Choose one of the faces and make six dimples (like the "boxcar" six on a pair of dice) using a ball burr. Try to make the holes of uniform depth and size.

3. Draw in your initials (in outline form) on one face of the cube. Using the inverted cone burr, outline them. Next, use one of the ball burrs to cut the surface away from around the initials. If you desire, also use your small chisel to clean up any of the edges of your initials you think need it. Now, texture the surface around your initials using the ball burrs by cutting lots of small random holes.

4. Turn the cube on another face and cut lots of tiny lines with the inverted cone burr, trying to make the surface look like it's covered with hair. If you like, try carving a feather on one face, using the inverted cone burr and chisel.

5. Now try hollowing your cube out on one face, to make it look like a small, thick walled box. Draw the side walls in, rough out the inside, and finish smoothing the inner walls with the small chisel.

6. Using any of the burrs you like, try to make the remaining face look like weathered wood.



"6" dice dimples

Initials

"Fur" texture

Feather

"Box" edges



Weathered wood texture

*Our First Carving Project: Carving the Duck Decoy*





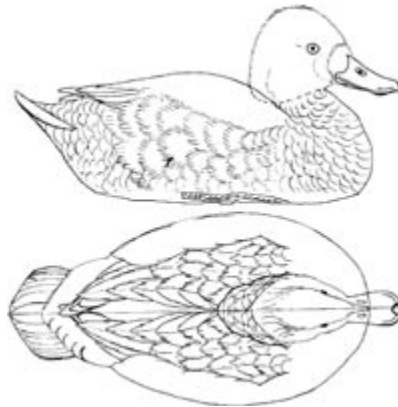

This duck is a bluebill duck, but you couldn't tell it by me. I know it's a bluebill because the pattern said so. It just happened to be a convenient pattern I had available, and easily altered for our purposes. Anyway, it's a fairly easy and straight-forward carving, but it demonstrates a number of important miniature carving techniques in an easily recognized format. Judging from the number of duck decoys I see at carving shows, it's also a very popular subject. Although the more technical details may be elusive, almost everybody has a basic idea of what the average duck looks like.

Begin by assembling the needed tools. You'll need various sizes and shapes of burrs for carving with a Foredom™ or Dremel™ type of rotary grinder. In addition, you'll need your small chisel, and polyester abrasive pads. You'll also find the tiny Dockyard™ brand micro-detailing chisels very useful, as well as

dental scrapers and jeweler's engraving tools. Locate a suitable type of wood, lay out the patterns, and saw to the outlines (I use a photocopy of the pattern, and apply it to the wood with rubber cement). Once I saw the outline on one side, I reattach the waste wood with rubber cement for easier sawing of the face at 90 degrees to the first cuts.



**Roughed out duck, center lines drawn in**

I started my carving with a band-sawn block of boxwood, and roughed out the major surface levels (see picture above). Be sure to leave the roughed out areas a little larger than needed. You can remove wood as you go, but it's certainly difficult to put it back.

Leave yourself a small margin for error (about  $\frac{1}{16}$  of an inch). Constantly refer to the pattern and any reference pictures you may have. If needed, measure distances with calipers or dividers, and depths with small dowels or toothpicks. As you near the finished product, be careful with metal measuring tools so you don't scratch the carved surfaces. Keep a center line marked (in pencil!) on the duck. As you carve portions of it away, re-mark it. Note on the rough out picture the "side pockets" carved on the side of the duck. These are large rounded feathers which fit over the wings when they are folded. Your duck should have a distinct long dent where the side pockets contact the wings. Once the duck is roughed out, use a coarse (brown) polyester abrasive pad in a mandrel to smooth it all over. On my rough out, you can see the small grooves left by the Carbide Kutzall™ I used. You'll need to remove all such tool marks, leaving a silky smooth surface to carve the feathers on.



**Head detail**

Now is the time to carve the head and bill. I left mine until the end...a mistake. When I tried to smooth the head with a polyester pad, I obliterated some of the feather detail on the front edges of the wings and had to carve it back in.

In general, I used the  $\frac{1}{16}$ " ball burr, with the smaller ones for finer details. Note the groove the eyes are set in. It extends from the back edge of the bill to the back of the head, then turns and starts down the neck. Also, note the cheek areas, and a larger bump behind them. I think that area is referred to as the "jowls." It's hard to see in the picture, but the bill has almost a small "hook" on the end. Look at some reference pictures or a study bill if you can. Don't forget the nostrils. I did, and had to go back later and carve them in.

I used a special tool to carve in the eyes. See the **Small Raised Dimple** texture section in this manual for instructions on how to make a similar tool.



### Feet and himotoshi detail

You need to decide now whether or not you're going to carve in the feet and the himotoshi (the two holes used to pass the hanging cord through). I used a .0382" ball burr to outline the feet and legs, then a tiny .0138" ball burr to make a visual separation undercut. Use the larger  $\frac{1}{16}$ " ball burr to shape the underside of the feet.

I carved tiny dimples on the legs to simulate the scale pattern on real ducks. If you want to make your carving a genuine netsuke you'll need to add the himotoshi's U-shaped channel. I carved my himotoshi using the larger  $\frac{1}{16}$ " ball burr. There is a U-shaped tunnel connecting the two holes. The insides need to be quite smooth.



### Wing and tail detail



Now is the time to begin detailing the wings. Referencing the pattern constantly, draw in the feathers on one wing (not both!). Once you have one wing carved in, it will be easier to draw the other one in to match. If you do it now, you may find that carving has altered one wing slightly, and then they won't match well. When you're drawing in the feathers, pay particular attention to how they overlap, and which edge will overlay its neighbor.

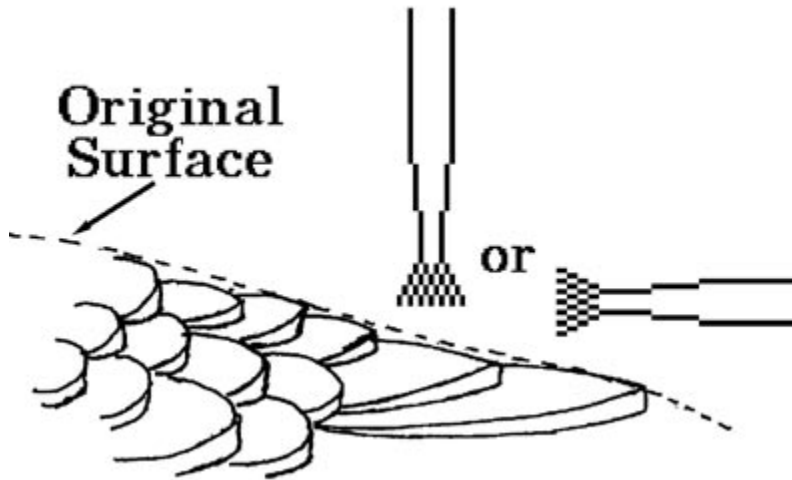

**Inverted cone burr and wing detail**

Take the inverted cone burr and carve the wing edges like little stair steps. You can hold the inverted cone either vertically in relation to the plane of the feather, or horizontally. Use whichever orientation feels the best and is best oriented towards the grain of the wood. Remember to always try to cut “downhill” (with the grain). You can successfully cut “uphill” (against the grain) with power tools much better than with hand tools, but the surface left by the cutters won't be as smooth as a downhill cut, and the tool may tend to try and “pull” or “run” in one direction or another. Since the inverted cone burr you're using is so tiny, you'll be left with little troughs outlining the feathers.

Use the small straight chisel to refine the feather shapes, and bevel the feathers from their tips down to the bottom of the inverted cone burr cuts. Leave the edges fairly thick, with the tips at the level of the original surface. This will leave the edges between  $\frac{1}{32}$ " and  $\frac{1}{64}$ " thick. Don't worry about that thickness, we'll take care of that very neatly later on. Remember, we're still working on only one wing!

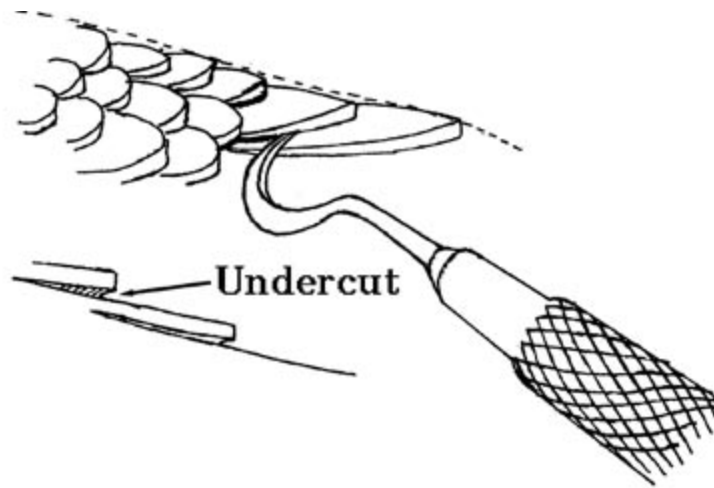

### Undercutting wing feathers detail

Once all the feathers on the wing have been outlined with the inverted cone burr and trimmed flush with the chisel, we're ready to create a visual separation by using the hook-shaped scraper to cut a small, dark line undercut along the bottom edge of each feather.

Place the point against the bottom edge of each feather and steadily pull it "downhill" along the edge. If you've properly sharpened the scraper it will cut a neat line along the edge. It may take several passes to cut the entire line. If you must scrape "uphill" (and at some point you will), then do so carefully. Uphill cuts run a greater chance of being directed off course by the grain, so be on the lookout for that to happen, and resist the direction change.

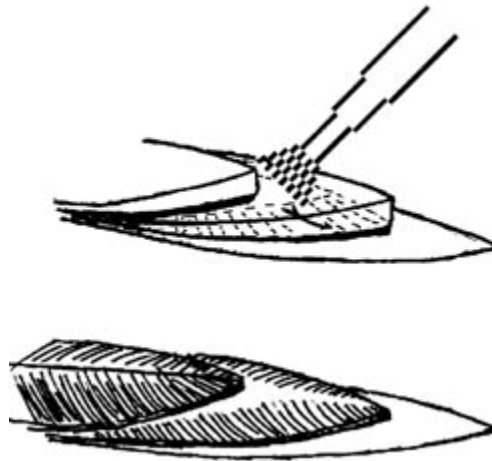

### Wing bevel and barbule detail

Now it's time to "neatly" take care of those thick feather edges like I promised. Taking the tiny inverted cone, and holding it a 45 degrees to the feather surface, make closely spaced cuts from **near** the center of the feather towards the outside. Slightly curve the cut towards the tip of the feather to simulate the

direction of barbules in a real feather. Press harder at the edges to cut deeper, thus removing the thickness of the edges. Try to leave the longitudinal center of the feather uncut, to simulate the center rib of a real feather. Since our duck is so small, we're not going to try and carve that rib. In larger scales you could do so by first carving in the center lines on each side of the rib with the inverted cone burr, and leveling the surrounding area with the straight chisel, then cutting in the barbules with the inverted cone. With this, you should be done with a single wing. Draw the mirror-image feathers on the other wing, using the first wing as the pattern, **not** the paper pattern. This will ensure your wings look the same. Repeat the above steps with the other wing.

Using a maroon polyester pad in the mandrel or a piece held in your hand, smooth the area, running the pad in the direction of the feathers, not against their edges. If we run the pads the wrong way, we may break off the thin edges.

Carve the tail feathers the same way you carved the wings. Pay attention to how they overlap, and realize that each half is a mirror image of the other. Note also how the center feather is portrayed on the pattern. Since the tips of the feathers are exposed here, carve the tops first, then draw and carve the bottom surfaces to match the top. When making the visual separation undercuts with the hook scraper, make sure the underside and top edge undercuts meet, giving the illusion the feathers are neatly tucked next to each other.

Once the wings and major tail feathers are complete, we're ready to carve the large side-pocket feathers. These feathers are large, rounded, soft-appearing feathers, somewhat similar to those in the shoulder area of the wing, but much more flimsy. Using the pattern, draw them (in pencil!) on one side only. If you draw them on the other side now, you'll only smear them while holding the duck and carving the other side, making a nice mess. Avoid smearing the pencil graphite into the previously cut texture on the wings. It's very hard to remove without re-carving the area. Using the larger  $\frac{1}{16}$ " ball burr (not the inverted cone), cut a groove along the outside edge of each large feather. We're not going to apply much detail here, in an attempt to get a soft look, yet still delineating the feather shapes. Don't use anything other than the larger ball burr to do this with, and don't use the chisel or inverted cone to define the edge of the feather. Once you have all the feathers in this area outlined with the ball burr, use the inverted cone to cut in the barbules on each. Be sure to use the inverted cone to level each feather somewhat. The effect we're aiming for here is for each feather to be sort of a small hump. While real ducks are quite smooth in this area, with tiny reticulated markings delineating each feather, we don't have that option. Using a little artistic license, we're going to use these small bumps and barbules to make an approximation of feather separations. Repeat the above steps on the other side. Breast, stomach, and back feathers are cut in the same way. Most of these are so small I don't bother to draw them in, just cut in a semblance of a pattern with the ball burrs, then cut barbules with the inverted cone.

We'll also use the larger and smaller burrs to put in the tiny feathers on the neck and head. Rather than putting barbules on these, since they are so small we'll just use short cuts with the ball burrs to simulate this texture. Practice on a piece of scrap until you find a texture that is pleasing. Remember all feathers on a duck point backwards to minimize drag in flight, so don't carve any of yours pointing forward. Pay particular attention to blending the different textured areas together. If you need to add or recarve feathers

in the transition areas, do so.

Finish your carving by soaking it in hot penetrating oil, either clear or stained, as you prefer. To get the liquid to penetrate the dense boxwood and eliminate the grain-raising effects of water based finishes, I use a Danish penetrating oil finish and literally boil the netsuke in it.

**Caution: The oil finish is flammable. Use a double boiler in a well-ventilated area, with fire extinguishing agents immediately available. One of the best is a lid large enough to fit completely over the double boiler to smother any flames.**

This generally takes at least one hour for boxwood to absorb enough of the oil finish. Take the netsuke out periodically, dry it off and examine to “see if it’s done yet.”

### *Our Second Carving Project: Carving the Sleeping Mouse*







**1 3/8" x 1 5/8" x 1 5/8" Completed June 1986**

The mouse is what I consider to be a classic of netsuke design, and always a favorite with crowds at carving shows. This one is patterned after several antique netsuke I saw at the Victoria and Albert Museum in London, by the famous Masanao line of netsuke carvers. This group of carvers handed down the Masanao carving name through at least seven generations, from before 1800 until about 1922. I've included a picture of the original in this article. The original had hair incised in tiny straight lines, but I liked the boxwood grain and color so well I left my version smooth.

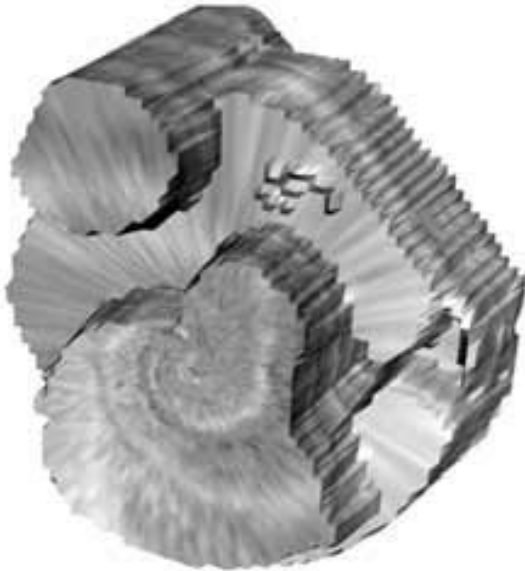

I started my carving with a band-sawn block of boxwood, and roughed out the major surface levels like stair-steps (see picture above). Be sure to leave the roughed out areas a little larger than needed. You can remove wood as you go, but it's certainly difficult to put it back. Leave yourself a margin for error. Constantly refer to the patterns, study cast, and pictures. Measure distances with calipers or dividers, and depths with small dowels or toothpicks. As you near the finished product, be careful with metal measuring tools so you don't scratch the carved surfaces.

Round out the details as you go, leaving the small details like eyes and feet for the last. The tail is textured with tiny, carved parallel lines, in rings along the length of the tail. Each of the rings is a different thickness from its neighbor; you can think of the rings as stacked paper cups. The tail should be shaped into one long tapering curve first, then the little stair-steps carved into it. If you carve the steps first, the tail will probably end up looking far too blocky. A little ingenuity or careful work with a scalpel or XActo™ knife will provide you with a suitable substitute. Incidentally, if you need a better look at a mouse, check out the neighborhood kids or take a trip to the pet department of the local department store. That's the beauty of carving the mouse; you don't have to go to the zoo or a taxidermist for samples.

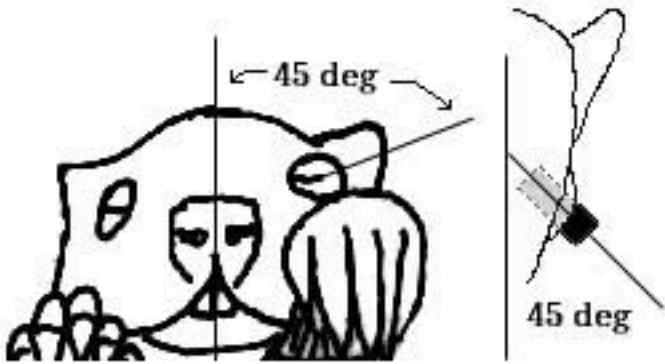

You can carve the eyes closed or open. The Masanao versions have dark inlaid open eyes. I left mine closed, and this may be the easiest option. If you want to carve open eyes, here's how to do it. Mice and rats don't have any detail in the eyes that you can see, like irises or pupils. Their eyes are basically round, so I would use tiny ebony pegs to provide the black eyes. Carefully drill holes the diameter of the ebony pegs in the right locations, **before** you do any detailing around the eyes. I find small ball burrs provide me better control than drill bits. In any event, practice on some scrap hardwood before drilling your carving. The holes are drilled at 45 degree angles to the front. This will make the eyes appear oval from the sides, but still be easily constructed from round pegs. Make sure the eyes line up on both sides of the head, when viewed from the front **and** the top of the head. You might want to use two straight pins for a trial placement before drilling. Drill well into the wood, since you'll be carving down into the wood; you don't want to cut below the depth of the pegs. Secure the pegs with epoxy cement. Carve the eyelids slightly bulging out from the face, and the black eyes protruding slightly beyond the eyelids.



I left my version smooth, but if you want to add hair to yours, have at it. Either way, carefully smooth all surfaces, even if you are going to add hair. I would use the inverted cone burr to apply as much hair texture as possible, held at 45 degrees to the surface. Make very light cutting strokes, parallel to each other and about  $\frac{1}{8}$  inch in length. Space the strokes as closely as you can. If you know how to draw pen and ink crosshatching, then you already know how to carve hair. You can make directional changes by slightly overlapping sets of strokes, and at slightly different angles. The hair typically runs from the tip of the nose towards the tail, and straight down the backbone. As you go farther down the sides, the hair turns more towards the belly, although it never turns at right angles to the nose-tail line. Refer to the picture of the Masanao prototype for hair direction, shown by the little arrows.

Finish your carving by soaking it in hot penetrating oil, either clear or stained, as you prefer. To get the liquid to penetrate the dense boxwood and eliminate the grain-raising effects of water based finishes, I use a Danish penetrating oil finish thinned about 50/50 with paint thinner. This generally takes at least several hours (even better overnight, if you can wait) for boxwood to absorb enough of the oil finish. Take the netsuke out periodically, dry it off and examine to “see if it’s done yet.”



## *Burnt Offerings: Pyrography and Small Carvings*



My wife, Mary Alice, and I collaborate on a series of art baskets (Mary Alice is the basketweaver, I carve the lids) and we're often asked about our "woodburning" techniques used on our artwork. This short tutorial on pyrography demonstrates the techniques we use for our art baskets and my knives. Pyrography is Greek for "Fire Writing," and is an art form probably as old as fire. Some artists today are advancing this peculiar art form by leaps and bounds with stunning "paintings", but it still has not caught on in the mainstream art world. There has been a new resurgence due to the popularity of bird and duck decoy sculpture. The burners used for this work are not the kid's clumsy burning pens we remember, which were more like pen-style soldering irons, and which were difficult to use and highly unsatisfactory. The newer units are small, hot knives capable of broad ranges of temperatures and intricate detail, and are a pleasure to use. Thank you, modern technology...

Pyrography has many advantages as we use it. Pyrography allows a wide range of lights and darks, and burned areas do not "run" or bleed in porous woods like liquid colors sometimes can. These light to dark browns and black colors are "in" the wood, with no chance of them being worn away without significant erosion of the material. Colors are not always "in" the wood and are sometimes fragile as well as fugitive (fade over time or in light). Pyrography allows a fairly substantial range of textures, with wide range of accurately placed lights and darks, with no color bleeding.

We'll start by looking briefly at Celtic line drawing. We started our Celtic careers by taking a Celtic line drawing course offered by Cheryl Samuel.

[http://www.ravenstail.com/celtic\\_line\\_drawing/celtic\\_workbook\\_series.htm](http://www.ravenstail.com/celtic_line_drawing/celtic_workbook_series.htm)

Here's a link to her Web site, where you can contact her for training, or to purchase her very well written and clear instruction booklets. They are delightful, and a great introduction to an enjoyable art form just in itself, and very reasonably priced. From her beginnings, we've developed a method to take highly detailed and interwoven Celtic art from paper to wood.

## Tools

We use a solid state control box, with two types of burning pens. The first is a small, hot knife tip. This tip outlines the areas to be darkened. The second type is a specially modified tip with a small point jutting off to the side, which is used to "stipple" the dark areas.



**The “Detailer”, by Colwood Electronics.** A good inexpensive unit, other types and other manufacturers also available.



**Two of the types of pens we use.**



### Detail of the tips

The following is a brief introduction to Celtic line drawing, which will serve as a small project to learn our style of constrained pyrography. I call it “constrained” because we will use no shading and limited texture, all contained within smooth outlines.



The picture to the left is what we’re going to produce when all of this is done. It’s the top rim for a basket similar to the basket at right.

**Celtic Basket**, (right) Maple rim with Waxed Irish Linen weavers.



Oh, yes, a very important part is the use of magnifiers. We are known for our extremes of detail and tiny art. While we do not intend for our work to be viewed with magnification, we find that when the work looks good in the magnifier, it looks great to the naked eye. Plus, there is that inescapable age and eyesight factor...



### Optivisor magnifiers

In real life, the design is drawn straight onto the wood piece, rather than using paper. For clarity's sake, we'll begin using paper for the pencil drawing parts, since we couldn't get the pencil marks on the actual wood to show up well when scanned. Sorry about that.

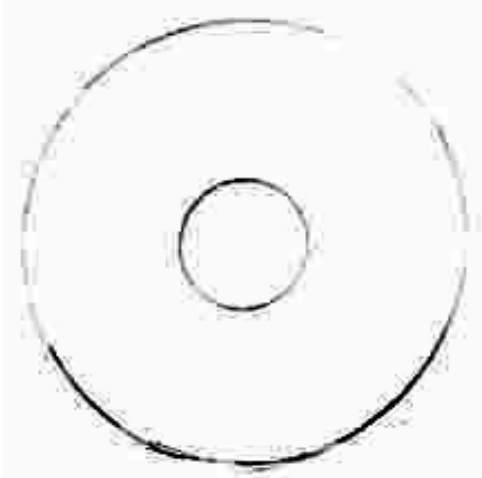

Here's the "wood" part (simulated by two concentric circles on paper).

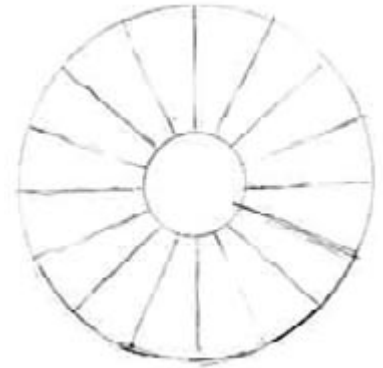

We begin by drawing 16 lines through the center. The number of lines are directly dependent on the size of the wood piece. This particular one is two inches in diameter, so we could get away with this many. Typically, the smaller the wood piece, the fewer divisions.

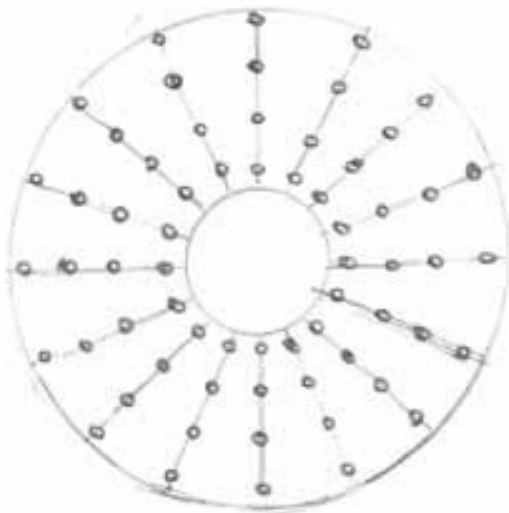

Next, we draw small circles along these lines. These are the beginnings of the Celtic line drawing system developed by Cheryl Samuel. The bigger the small circles, the thinner the final ribbons. Conversely, the smaller they are, the larger the ribbons are.

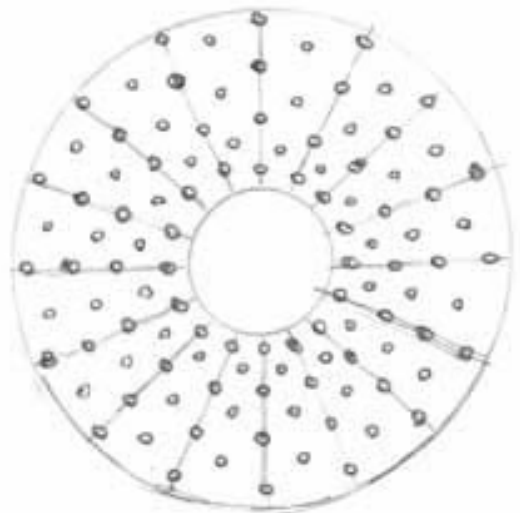

Next, little circles go between each four of the circles we drew in the previous step. Don't forget these center circles; forgetting these is the most common error.

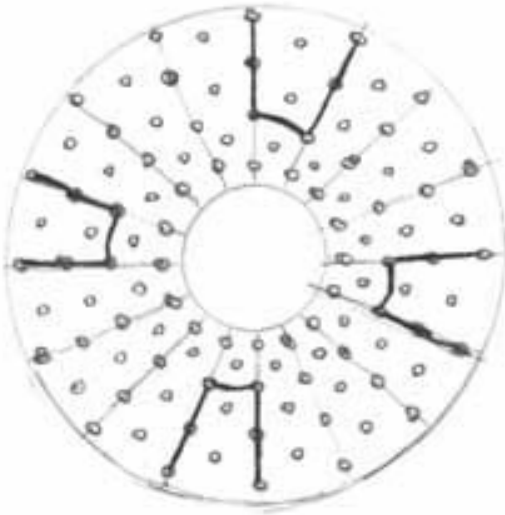

In order to provide a little visual interest, we've added in "cuts" (the darker lines). These are like little stop signs, and the ribbons are not allowed to go past the cuts. They have to bend around and "reflect" off of the lines.

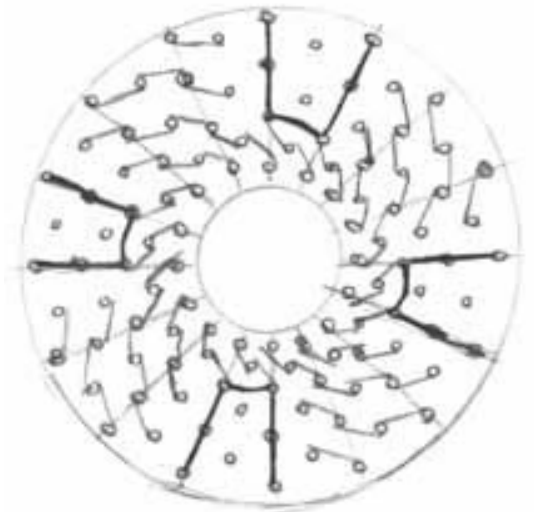

Now, starting clockwise, we begin a series of under and over lines connecting the little circles. There are specific (but simple and easy) rules which govern this behavior. Note how they stop at the cuts.

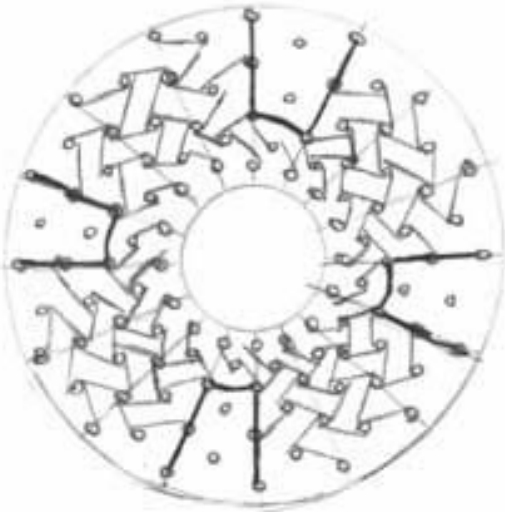

Once all of the clockwise over and under lines are in place, we go back counter-clockwise and do the same, with slightly different rules. You should be able to see some of the ribbons beginning to emerge.



Note that the ribbons, while visible, aren't terribly neat, and they're missing the outside and inside turns. In this step we begin to add these in, and neaten up the ribbons.



Here's the completed design. Up to this point all has been drawn in using pencil (lightly!).



I've drawn the same pattern on the wood. As I stated before, I would normally have done all the preceding steps on the wood only. At this point, we put away the pencil, and take up the knife burning tip. We begin by outlining the ribbons with a fine, dark line using the knife tip. Here, several of the ribbons have been outlined, and you can see the pencil design.



Here's a close-up of the hot knife tip we use for outlining. Incidentally, you sharpen this hot knife exactly like a regular knife. Keeping it sharp ensures fine lines and good control. Remember, you can erase pencil lines, but burned ones don't come off!



Here's the entire design outlined with the hot knife. You can still see the pencil design.



Next, the pencil design comes off. We lightly(!) use an abrasive Scotchbrite pad in a mandrel on a flexible shaft grinder to erase the pencil marks. Here's the piece without the pencil marks. It's important to do this now before the dark areas are added.



Scotchbrite pads come in a variety of abrasive grits. This is a medium grit (purple color). We cut small squares off and chuck them in a 3/32" mandrel. They'll become round very quickly as you use them. Be sure to place small washers on each side of the pad, or the pad will simply rip free. We use them at about half speed in a Foredom flexible shaft grinder.



Now we begin to add in the dark areas. We do this by using the other tip, with the tiny point jutting out the side.



Here is a detail of the tip we use for stippling (the tiny burned dots). Stippling produces an area with dark dots, and a wonderful fine texture. This tip was modified from a standard commercially available tip with small grinding burrs. This tip is quite sharp so it will burn tiny dots. We also use this tip to sign our work.

It's important to apply the stippling in random patterns, rather than lines or circles, which look too regular and have an odd appearance. Also, we work on a small area, then move to another area to allow the previous

area to cool. The wood near where the tool is burning these tiny stippled dots tends to scorch when the tool stays in one area too long, so we hop around a little.



Here's the finished article.  
Time for a break to rest the  
hand and the eyes.

## Here are a few Celtic and other items using pyrography:



Feather pyrographed  
in maple.



Pygmy Owl carved in box-  
wood. Feather details are





Celtic maple lidded basket, carriage cane weaver

## Line, Color and Shading



Dragonfly pyrographed in maple. Color can be added in the form of very diluted paint or fabric dyes if the areas are completely outlined with the hot knife. Colors will not tend to run across the cuts IF you are careful.

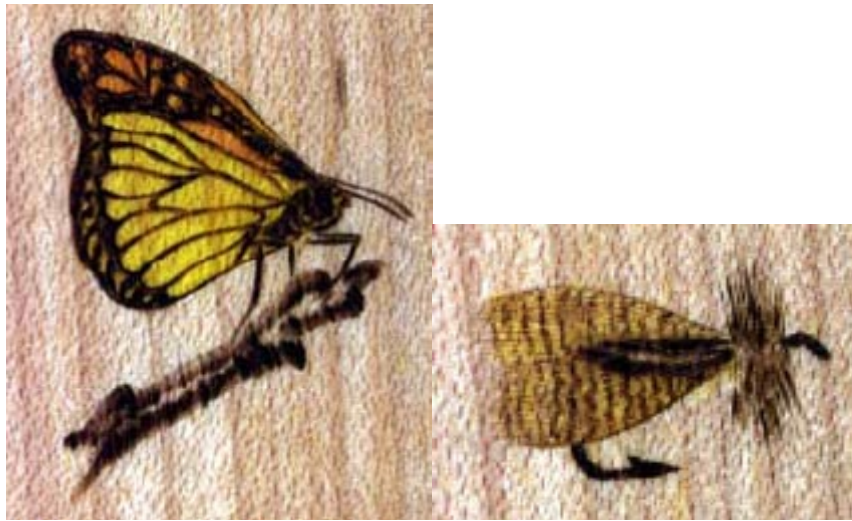

**Butterfly pyrographed in maple, colored with fabric dyes.**

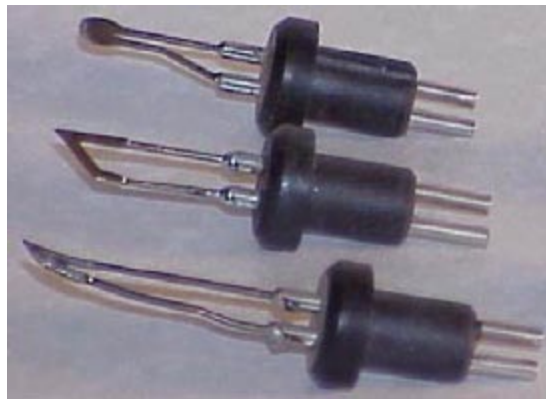

Here are a few of the tip shapes available that I like to use. The top pen with the thick bent wire tip is useful for stippling, but providing much larger stipples than the tiny tips I've shown you so far. When stippled burns are closely spaced, this tip makes wood look somewhat like hammered iron. I don't use the paddle-shaped tip at the top as is, but instead alter that shape to make the tiny stippling tips. I use small diamond burrs in my electric grinder to shape it as desired. I often prefer wood burning over the conventional "v" cut for lines and dye control. Wood burning provides several advantages over the "conventional" v cut technique. First, the line left by wood burning can be of a light to dark brown color, requiring no additional undercutting to be well visible. Wood burning also allows better control of detail and better durability. It's also simpler, since a burned cut requires only one pass, whereas a v cut requires two.

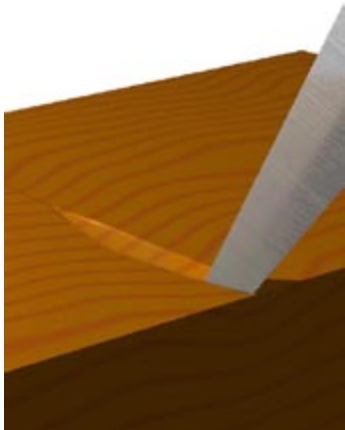

V-cut: First Knife Cut

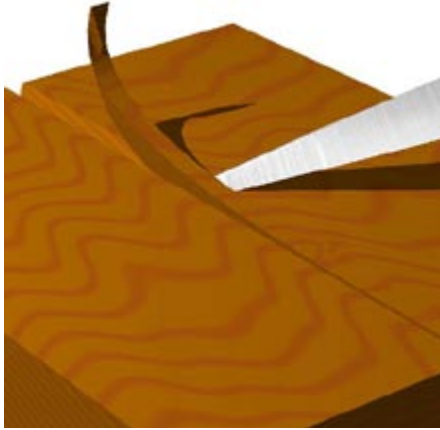

V-cut: Second Knife Cut

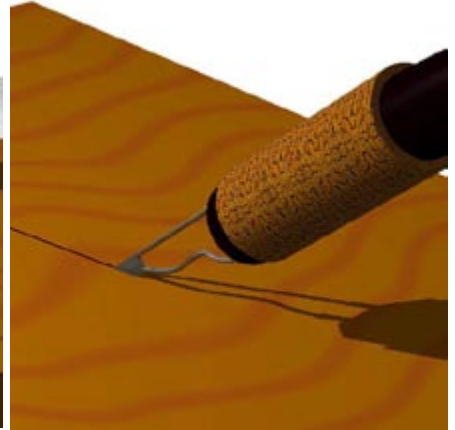

Burned Cut



**Line Texture**  
Dark to Light



**Stipple Texture**  
Dark to Light



**Dot Texture**  
Dark to Light



# Anatomy of a Pyrographed Netsuke: Pygmy Owl

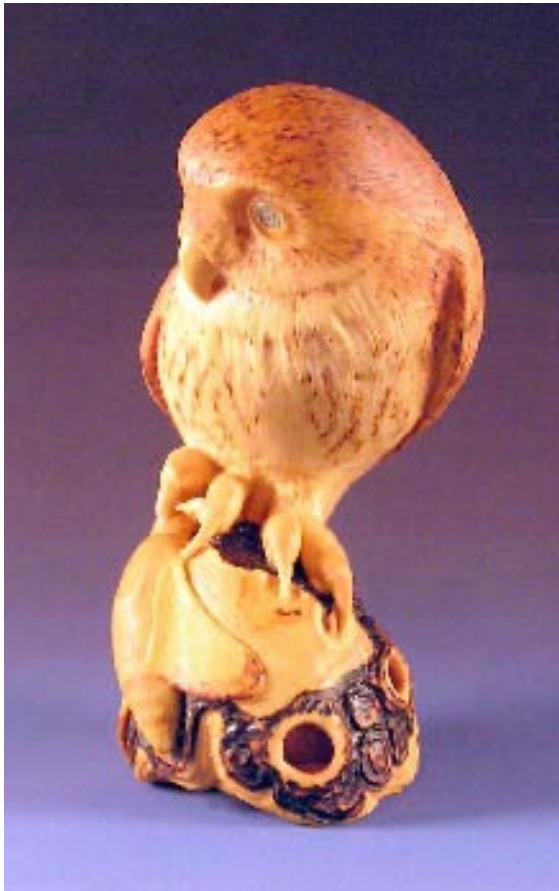

## Eyes: The Windows of the Soul



Carved in English Boxwood. With the addition of the eyes, I'm ready to begin burning and dyeing the feathers. All that is needed to finish the carving portion is attention to final smoothing.

**Burning: In the Beginning**

Here, I'm using low heat to texture the feathers around the eyes and white breast. I increase the heat to obtain a darker brown in the areas where the feathers have dark streaks. These are short strokes in the direction of the feathers, using the little knife blade burning tip.

**The Task Goes On...**

Note the barring on the tail - requires a steady hand, and strong magnification.



Here you can see the moth. I've textured at low heat and added darker areas, followed by careful application of yellow dye, making sure it doesn't run into unwanted places.



I've been working on the rotted wooden stump the little owl is sitting on, using very high heat, and the bent wire tip, trying to make the very dark areas look like bark.

Tom Sterling

Carving Netsuke



And On...

Until Finally One Day...**Everything Comes Together!**





## Our Third Carving Project: Carving the Baby White-Throated Sparrow

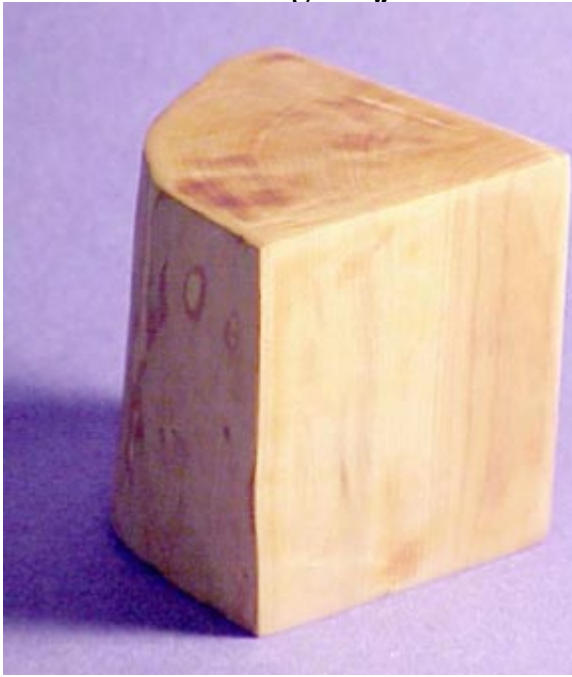

Here, most of the carving is complete, the eye holes have been carved and we're ready to begin adding in the carved and woodburned feathers. I'm using English boxwood, my favorite. I've also used a two-part wood bleach, available at most hardware stores, to bleach the normally yellow boxwood closer to white.



I've burned in the primary wing feather outlines with the small knife-tip woodburner. These outline burns are fairly deep and serve as stop cuts, as well as adding color. Following that, I used knives and small chisels to carve the wing feathers flat so the feathers appear to overlap.



I've added the amber eye pegs, and begun outlining the smaller wing feathers, using small burrs and chisels. With this type of simple eye, I used a little india ink to blacken the insides of the eye holes before gluing in the amber pegs with epoxy. Small bird eyes just look like dark circles, since you usually can't see the pupils. Be sure the ink is dry before gluing.

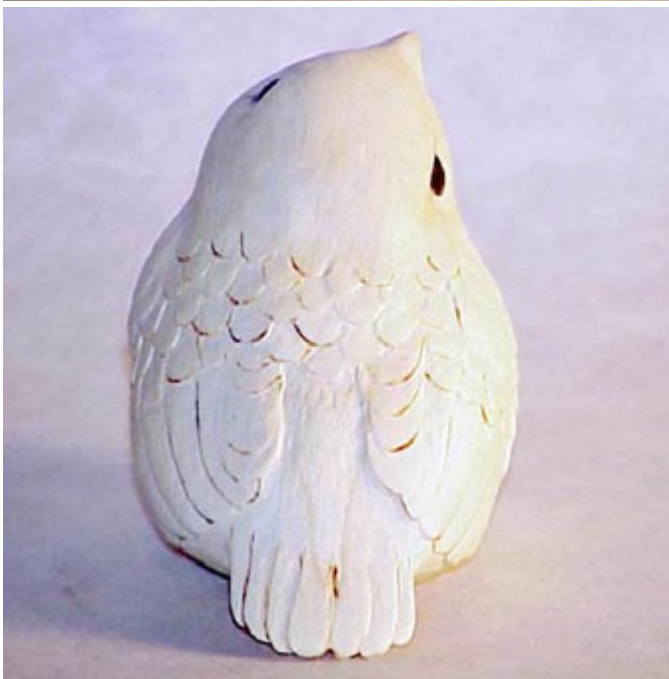

I'm using a small round diamond burr to outline the round feathers of the breast. I'm not using the wood burner to outline here because these feathers are small and soft, without much detail. I just want the "lumpy" look, rather than smooth, polished boxwood. I've also begun burning in the detail on the wing feathers. I start by burning two tapering lines for the center rib, then add in the barbs at a typical angle. I burn at medium heat for the center ribs, and use only low heat for the barbs. I'll come back later and add darker details in the barbs. I also burned and carved the tail feathers similar to the wing feather technique.



Here, I'm working on the darker barb details I promised. Notice I've left the edges of the wing feathers white, as well as the breast feathers to match the feather patterns on a white-throated sparrow. Also notice I haven't put any central rib details on the soft breast feathers. I also dyed the bill yellow. I prefer to operate under the principle of "graceful degradation." I dyed the bill now, so that should there be any unfortunate runs or spills, I could take care of the problem before I added much detail around the mouth area.



Adding more and more feather detail.



I've added in the himotoshi, done the final carving of the feet and left a signature reserve. Plan ahead! The tail feathers are detailed, and I've darkened in the smaller wing feathers, with more little white edges left undarkened. Also, notice how I textured the underside feathers near the feet using little burned color, but adding in small streaks of darker color, just like on the real bird. Don't forget to research small details like these if you want a realistic appearance.



Finally, all the feather details are in, and I've added the dyes (Procion™ brand). I've used pure Procion™ lemon yellow near the beak, and gray for the breast and tail feathers (combination of Procion™ sky blue and a tiny bit of Procion™ dark brown). All of the browns come from the burning. Prior to the dyes, a VERY light going over with a maroon polyester pad just for a light smoothing. Don't sand away your hard-won detail! I used a straight yellow for the beak area. A mixture of dark brown with a little sky blue makes the blue-grey for the breast and rump, with a similar mixture with more brown for the brown feather areas. The white is the natural color of the wood. A linseed oil finish overall is the final application.

Oh, yes, I use my smallest ball burr to carve my signature, followed by refinement with a small dental scraper. Then I apply a dilute (thinned with lacquer thinner) coating of clear lacquer (I prefer the Deft brand) to the signature reserve and down in the signature itself. This will seal the wood so the final application of colored ink won't run into the wood. I apply the ink with a fine tip artist's dip pen

### *Netsuke Patterns*

The following pages, are of netsuke that I have carved over the years, along with a few actual patterns. The patterns are approximately life-sized (the size of the actual netsuke, not necessarily the size of the original subject). They are for your use, and may be reproduced for non-commercial carving, or by instructors for the purpose of carving instruction. They are copyrighted and may not be repackaged and distributed or sold. For further information on the copyright, please see the copyright notice at the beginning of the book.

Please feel free to copy any of the carvings you see in this book. They are either mine and the copyright is owned by me, or are antiques that I own whose legal United States copyrights have expired many years ago. Copying is how we learn; however, once you have carved a few pure copies, strive to make each new carving your own work by adding to or altering the original design. Copying is useful for learning techniques, but copying alone can only make you a technician, not an artist. Becoming an artist requires your own interpretation and creation. The old saying "a worker uses his hands, a craftsman uses his hands and his head, and an artist uses his hands, head and heart" is really quite true. With each new carving, strive to try something new, add a new feature or change an interpretation. As soon as possible, strike out on your own with your own ideas. I promise it will be a fulfilling experience!

#### **Pattern: Snail on a Bucket Netsuke**







One of the classic netsuke designs and my first netsuke. It's of a snail on a bucket, done in desert ironwood. Believe me, it photographs a lot better than it shows in person. It was carved with a very limited set of chisels. A novice carver with the minimum set of tools recommended in the Tools List should be able to do at least as well. Just goes to show you, practice really does help improve carving abilities. While it now

looks extraordinarily poorly done to me now, at the time I was very proud of it. From lowly beginnings we progress, I suppose. I see this one in netsuke reference books quite often. You can carve the bucket with the old fashioned sapling hoops, or with metal bands, like the crab in the bucket pattern I've previously carved. The bucket would look good really old and weathered. You might also try differential staining on the snail shell using painting frisket as a mask (look for frisket in art supply stores). Mask off some spots or tiger stripes on the shell, soak in clear linseed oil, then remove the frisket mask and soak in dark Danish oil for contrast.

**Pattern: Manju Netsuke**



**1 13/16" diameter x 5/8" thick Completed January 1986**

My second netsuke, adapted from one I saw in the Victoria and Albert Museum in London. I made it from a slice of antique ivory billiard ball. Manju netsuke are so named because they look like the Japanese rice cake of the same name. The antique versions are masterpieces of low relief. There is a hollow manju called a ryusa (named after the carver who invented the style), with the design pierced through to the large empty space in the center. My version depicts a moon among low flying clouds, waving grass and flowers. I mainly used barrel shaped rotary cutters since it is mostly shallow relief carving, followed by scrapers. The texture of the clouds was made with a homemade tool. I took a large needle, and ground a four-sided tapered point, and sharpened the corners of the point. With the needle in a wooden handle, I made tiny holes by rotating it against the ivory. If I were to do it again, I'd use either my hammer hand piece, or a v-pointed engraver to make tiny triangular holes. I darkened the textured and undercut areas with India ink. The moon gave me a little trouble. It is a highly polished area, and I kept using the rotary hand piece at too high a speed causing little brown burned areas in the ivory. I then had to scrape them down to white ivory and start again a word to the wise. For some reason, this netsuke has proven quite popular at shows. Odd, because manju types are not the most popular with collectors of antique netsuke.

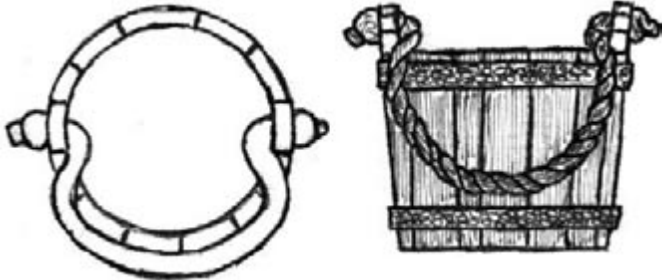
**Pattern: Crab in a Bucket**

**1 5/8" x 1 3/8" x 1 3/8" Completed August 1986**

The bucket is made of boxwood, and is stained with a dark Danish oil finish. Boxwood grain is so tight I had to "boil" the bucket in the Danish oil finish for 2 hours to get it to take any stain. I'm particularly pleased with the way the rope handle turned out. In person, it really looks like old rope. I textured the rope and bucket staves with a small dental tool I found which looks like a small file. This might also be done with a short section of a fine toothed saw blade (like a hacksaw or jigsaw blade), the corner of a coarse file, or a small riffler if you can't locate an appropriate dental tool. I simply carved a deep groove to separate the bucket staves and drew the file-like teeth along the stave lengthwise to simulate weathered wood texture. The rope handle was done by carving the main twisted parts of the rope in, and then using the file teeth to simulate all the tiny fibers. I decided on having metal hoops for the bucket, so carved them, and then textured their surfaces with closely-spaced gouge marks to simulate hammered metal. I made a special tool to make the rivets, and then carved the end where they overlap, and left the rivet area standing proud. The tool was a short length of small-diameter metal tube, filed flat across the end, and then sharpened with

a file and stone to create a cutting edge. The easiest way is to chuck the tube in the rotary hand piece and hold it against the file and sharpening stone. The rivets are made by pressing the rotating tube against the wood so it cuts in about a millimeter or so, leaving a small round trench around a round center. Then carve the wood away around the rivet head down to the bottom of the circular cut and leave the center area raised above the surrounding surface.

The crab was made from a piece of antique ivory billiard ball, and has scrimshawed dots darkened with sepia ink. I didn't use a pattern for the crab, so I leave it to the carver to develop. I first carved a piece of ivory into a small cylinder that fit tightly in the bucket (using the carbon paper technique to achieve a good fit). Then I drew a rough outline of a crab on it, and began detailing. I constantly placed the crab in the bucket to get an idea how the crab would look, and carved only those parts that would show. It looks good from the only vantage point the bucket allows, but it certainly looked odd before I fastened it in with epoxy glue. Be sure to roughen both the base of the crab and the bottom of the bucket so the glue will form a good bond. Of course, the bucket pattern is useful for placing other things in, not just crabs. Fish, flowers, vegetables, etc., would all look good. One of the classic designs of netsuke is a snail on a bucket. Use your imagination.

### **Pattern: Crab in the Weeds**





**4" long, 7/8" diameter Completed February 1987**

The crab was made from a small whale's tooth I found in an antique shop embedded in some sort of trashed "object de art." It was my fourth attempt at a netsuke, and represents a scene from some of my fondest memories. Near my grandparents' house in Florida was a small spring fed river that fed into the Gulf of Mexico. We went fishing there often. Through the crystal water you could see hundreds of blue crabs on the limestone bottom, hiding in waving fronds of aquatic weeds. This was an attempt to capture those memories. (Overall, not too bad for an early carving.) I was in a pretty remote place at the time I was carving this, and had difficulty finding good research material on crabs. The crab's shell isn't quite right, and he should have one more leg on each side. Oh, well, live and learn. The back side of the tooth and the root were left unfinished as a contrast to the smooth, glowing translucent polish on the carved areas. This netsuke was carved using small round and barrel rotary cutters and dental scrapers only; I hadn't discovered the micro chisels or engravers at the time.

**Pattern: Hatching Dragon**





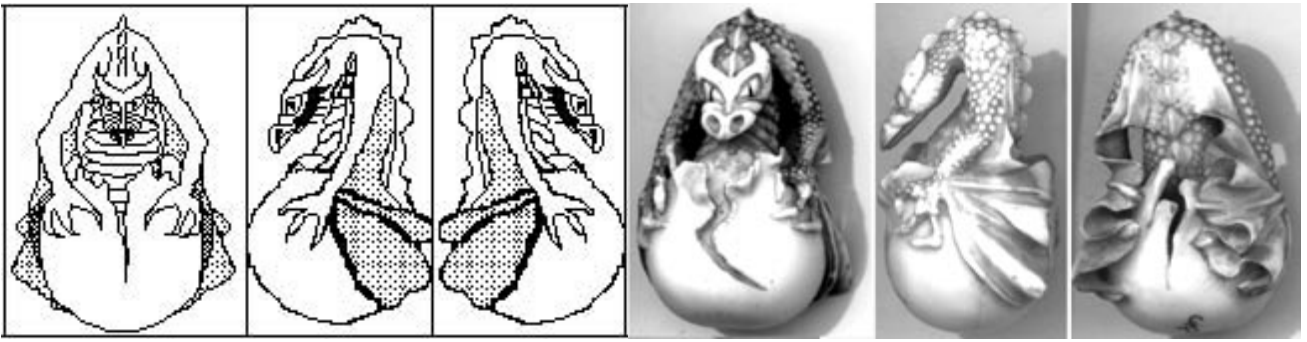

**1 1/8" x 1 3/4" x 1" Completed January 1988**

This little dragon hatching from an egg is made from a piece of hippopotamus tooth I discovered in an antique shop. The tooth was part of a Victorian gong setup, which was missing the gong. I discovered how hard hippo tooth enamel is with this piece, and destroyed a bandsaw blade in the process. I also worked out the procedures for applying ukibori to ivory pieces on this netsuke. The himotoshi is formed by having the dragon's arms separated from his body on both sides. I used rotary cutters and homemade chisels on this piece. The dragon was stained by boiling in tea. I'm not really pleased with the way it stained. Some parts stained fine, others didn't take any. You can see one of the areas that didn't stain well on the front of the dragon's left arm. I suspect the acid bath to produce the ukibori bumps may have had something to do with the differential staining. I used candle wax dissolved in a little turpentine for the acid resist. The bumps vary in size, with smaller bumps on the forearms, getting bigger the higher up the body they go. The egg surface and the horns and face area received extra polish to remove the stain. Final polishing was done with toothpaste! I couldn't get any jeweler's rouge where I was at the time, so I made do. Surprising what you can come up with when necessary. As I recall, I used India ink to darken the pupils of the eyes. The membranes of the wings are carved quite thin on the edges, and taper more thickly towards the interior of cavities for added strength.

### **Pattern: Octopus in Basket**

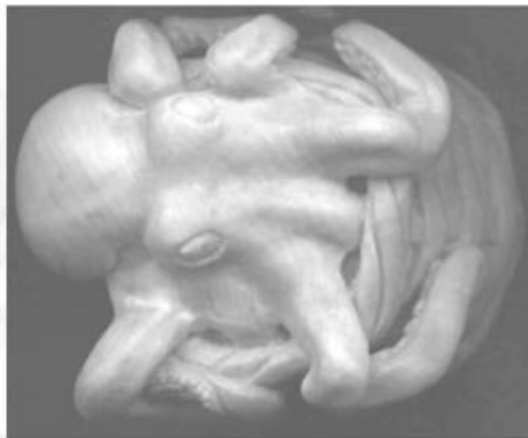

**1 3/8" x 1 5/8" x 1 1/2" Completed May 1988**



This piece is of boxwood, left natural color, and finished by oiling in clear Danish oil. The himotoshi is formed by the right front leg (if one can say that about an octopus) or the left rear leg projecting out from the basket. Detailing was done with micro chisels and engravers. I think this was the first carving I did with both the micro chisels and engravers, and I can see a lot of difference. It was a fairly straight forward carving, with the only tricky area being the basket. It's easy to get lost and make pieces go over or under the wrong way. Just draw in the weaves carefully. The weaves are carved by roughing out with the rotary hand piece and barrel cutters, then inspected carefully to make sure they are right. First I tried up the edges all around, then slightly rounded over the top surfaces. Be sure to make them look as if they flow smoothly over and under the vertical weaves. Once that looked correct, I undercut the edges with a sharp-edged engraver to separate all the elements. The weaves that finish off the top edge of the basket were carved especially deeply in some spots with tiny rotary cutters. Some of them you can look behind and beneath so they look loosely twisted, adding some visual interest to the basket.

**Pattern: Hermit Crab**



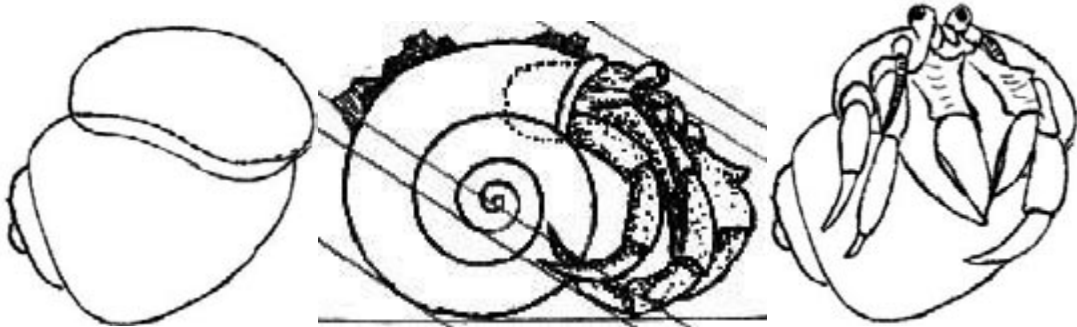

1 1/4" x 1 1/2" x 1 1/4" Completed April 1990

The hermit crab was made from two materials. The shell is ebony, the barnacles and crab are in ivory (elephant) from an antique billiard ball. I carved the shell first, then the crab. I achieved a good fit by repeatedly fitting the crab into the shell cavity with carbon paper to indicate the areas where more material needed to be removed from the crab (not the shell). I used epoxy glue to fasten the crab into the shell, and instant cyanoacrylate glue to fasten on the barnacles. The epoxy should be permanent, but I sometimes wonder how long the instant glue will last. Only time will tell. The bumps on the crab were made using the ivory ukibori technique mentioned in the text (muriatic acid bath with wax mask). The himotoshi is

concealed in the two large barnacles on the back of the shell. The straight lines on the side view indicate your eye level in the front view; in other words, the front view is rotated up to show the crab straight-on. Remember that the legs must have sufficient gap between them for the feet to contact the shell. Only the claws are not touching the shell. On retrospect, I feel the effect would be better with a light wood crab and ebony shell, or ivory crab and lighter wood shell, rather than the stark contrast of ebony and ivory. (I carved several early netsuke using similar stark contrasts, but maybe my tastes have mellowed over the years?)

**Pattern: Octopus on Broken Pot**



1 3/8" x 2 1/8" x 1 1/4" Completed May 1991

This is a multi-media netsuke. The octopus is of silver, the barnacles are of hippopotamus tooth, the pot is of desert ironwood, and the oyster cluster visible through the broken part of the pot is of natural color boxwood. Although the octopus is of silver, he was originally carved in wax, and cast by the lost wax method. This piece has turned out to be one of my favorites. I developed a method for simulating pottery texture with this one. The pot appears to be a rough-thrown pottery storage jar or tall flower pot, broken and thrown away. You can see finger grooves from the manufacturing process around the outside. My first attempt at texture used a small abrasive diamond ball, repeatedly chattered across the surface leaving small dents. This was moderately successful, but I eventually found a better way. I first used a small wire brush in the rotary hand piece, and cut it fairly hard against the grain. Incidentally, the grain runs from the top to the bottom of the pot. I used greater pressure in some spots, and less in others to make the finger grooves appear slightly uneven. This left the surface with tiny lines around the circumference. After that I used a broken rotary cutter shaft (missing its cutter head). The broken point was quite sharp and jagged, and I bent it very slightly so it would not run true in the rotary hand piece, describing a small circle when running. Then, I let the rotating point dance all over the surface and roughen it. After the surface was marked up quite well, I rubbed it down with fine steel wool and wet the surface with the finishing oil I intended to use. The oil is important because it often changes the appearance of a piece significantly, especially by darkening the wood. By wetting the surface I was able to judge how the texture would look when finished. Be careful only to remove the rough splinters, and not the texture. I repeated these three steps several times until I was satisfied with the look.

### Pattern: Sometimes the Dragon Wins!

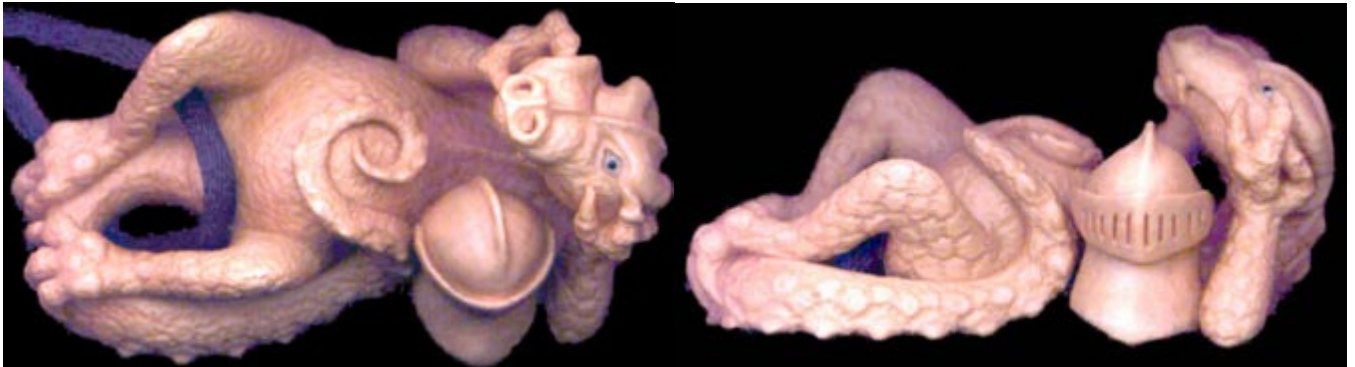

This guy was just for fun. I carved and sold him before I had a decent camera, so I'm afraid this is as good as it gets. You can't see it, but he's picking his teeth with the claw on his right hand/paw.

**Pattern: Wasp in Gourd**



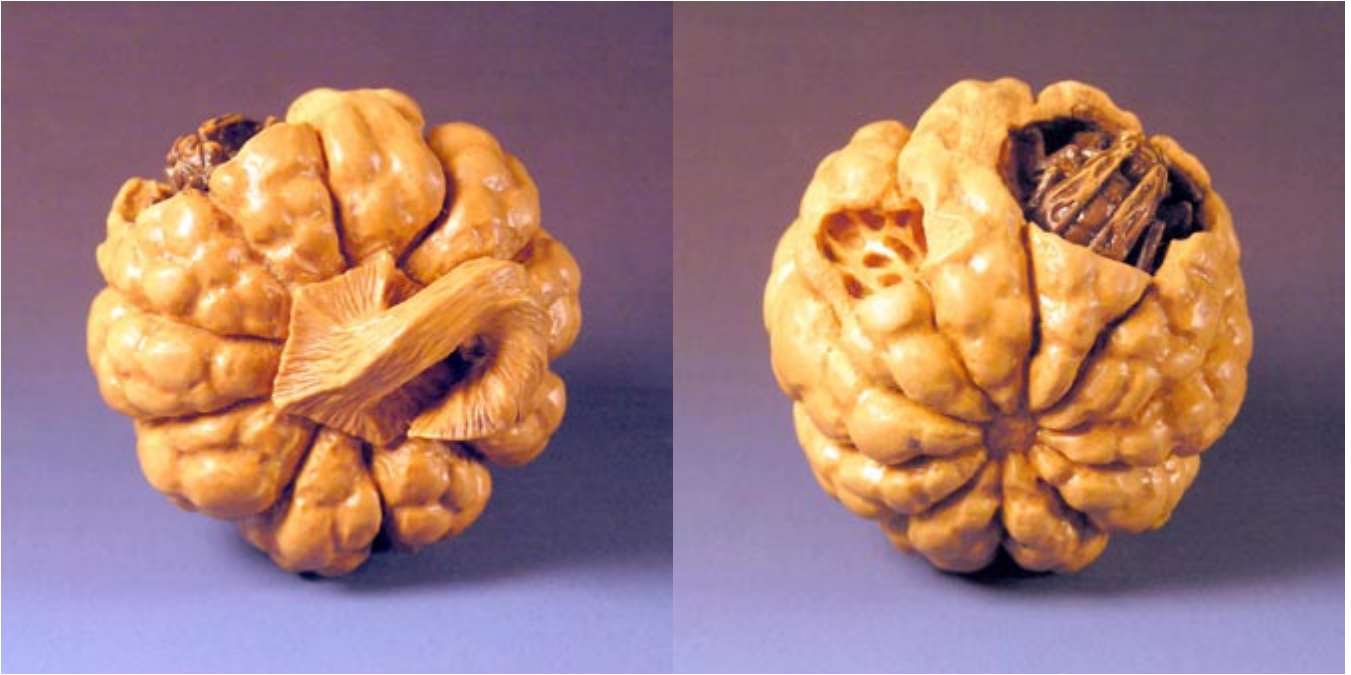

**1 5/8" x 1 5/8" x 1 5/8" Completed June 1992**

A wasp in a half-eaten vegetable or fruit is another classic netsuke design. My version is a wasp in a gourd, in natural colored boxwood. The gourd is one of those knobby, decorative kinds you see at Halloween. I used pointed rotary cutters to carve the grooves in the gourd, then switched to ball cutters of various sizes to carve the bumps. I used large cutters first, then decreased sizes as the bumps got smaller. The troughs between the bumps have rounded bottoms, and the vertical grooves have pointed, narrow bottoms. The interior is carved to look like the stringy fibers you see in pumpkins, with several large interior holes where the wasps have eaten. There are also several other holes around the outside. The edges of all holes were textured with the hammer hand piece to look eaten and dried out. The stem is quite twisty, with the texture spiraling around it. The bottom of the wasp is continuous with the gourd for strength, and the legs were carved as thin as I dared. It is quite sturdy because the wasp is completely below the surrounding surface. I textured the wings with very shallow gouge cuts, and the separate areas of the wasp's anatomy were detailed with my tinniest ball cutters. I don't provide a pattern with this one, since I don't feel it would be very useful. I simply started to carve, and wound up with this. Look at a reference book on insects for pictures of wasps or bees. You could also use beetles or grubs instead.

**Pattern: Hatching Alligator**







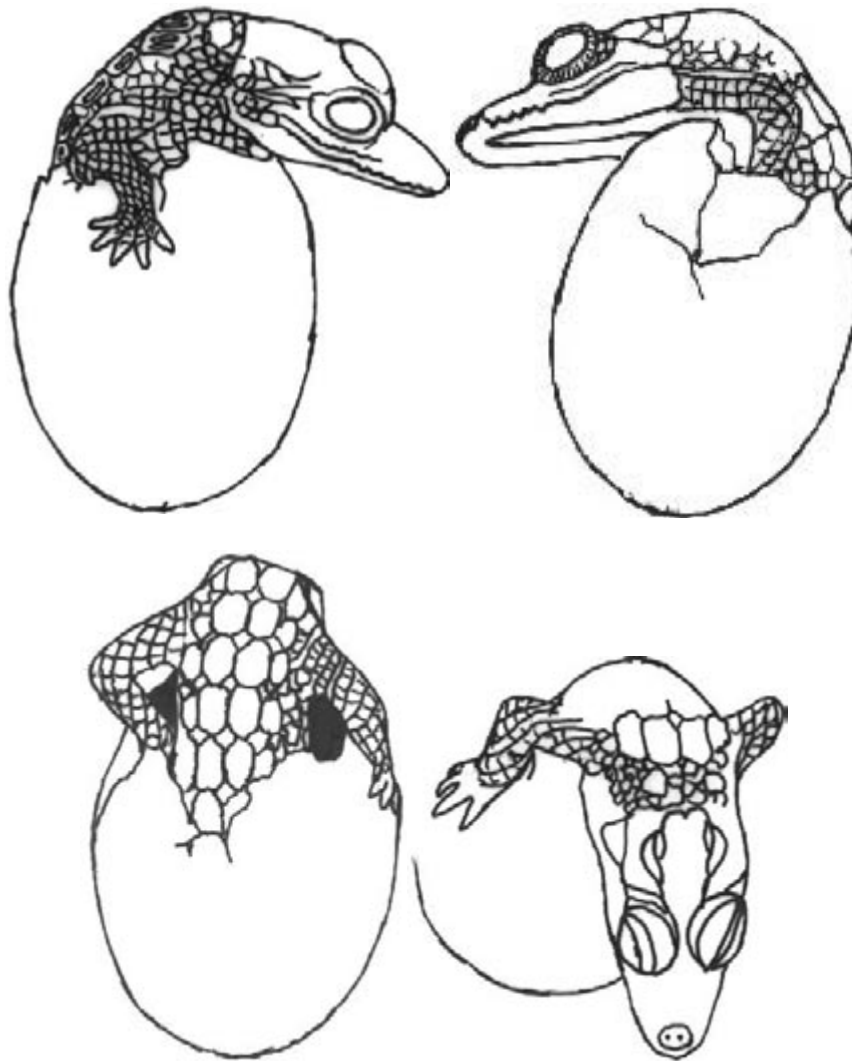

**1 3/4" x 2 5/8" x 1 1/8" Completed December 1992**

This little alligator is made of a single piece of naturally-finished boxwood. While living in England, I made the acquaintance of a gifted ceramic sculptor who specialized in creating exquisite baby dragons hatching from the egg. When I saw a picture of a hatching alligator in a book, it reminded me of his baby dragons, so I decided it would make a good subject. This was a tough pattern to develop. The picture I had that I liked didn't show any of the baby's arms out of the egg, so I had to look at many other pictures to figure out how they might look. My favorite picture also only had one view, and not a very large one at that. I also learned that crocodylians lay eggs with hard shells (more like chicken eggs), not eggs with a flexible membrane like most other reptiles. To achieve the look of an alligator straining to get out of the egg, I had to tilt his head at about a 30 degree angle, so no blocked-out, straight-on pattern could be drawn. That was a little bit of a challenge. The scales on these beasts are fairly regular on the bottom side, basically squares and parallelograms, becoming irregular towards the top of the body. Needless to say, I drew them in very carefully with India ink (I didn't want them to rub off while I carved), constantly referring to

research pictures and patterns. I carved the large scales by first drawing them in, then outlining them with my tiniest detailing ball cutter. The smaller, more regular scales I outlined using a sharp-tipped triangular engraver. Once outlined, I used micro chisels and engravers to clean up the spaces between the scales and slightly rounding in the larger ones.

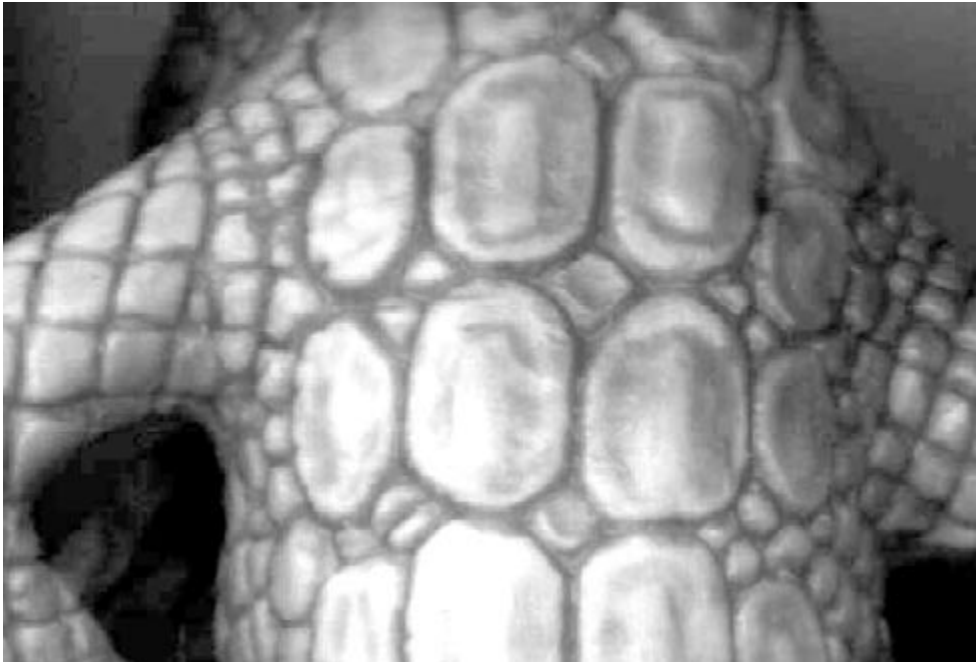

**Scale Details (Back of Alligator)**

Then I took larger ball cutters and carved in the detail on the large scales on the back. Note the detail picture of the large back scales. After the scales were well defined, I used abrasive polyester pads, both in the rotary hand piece and by hand, to smooth them down to the thickness and definition I wanted. The bottom edges of the jaw have no scales, and I achieved a rough pebbly look with the hammer hand piece, followed by abrasive polyester pads. The eyes I roughed in with rotary cutters, and detailed them with micro chisels and engravers. Once I had them looking like I wanted them to, I smoothed the eyeballs with extremely fine emery paper on tongue depressors, and followed that with polyester pads in the rotary hand piece. The egg's final smoothing was with emery paper and polyester pads. Once it was as smooth as I wanted, I went back and cleaned up the broken eggshell edges, which had been rounded over by the smoothing operation. I completed the hatching alligator carving with a 2 hour boiling in clear Danish penetrating oil finish, and a Hut™ stick polish and waxing. Optionally, this design would look good with a differential staining, darkening the alligator, and masking the egg for a final clear finish. Also, instead of leaving the egg shell smoothly polished, you might try for an “eggshell” finish.

### **Assorted Patterns Yet to Carve**

Here are a few more patterns. I always intended to carve these, just never got around to it, so I don't have pictures of finished carvings to show you. Maybe you'll finish these for me.

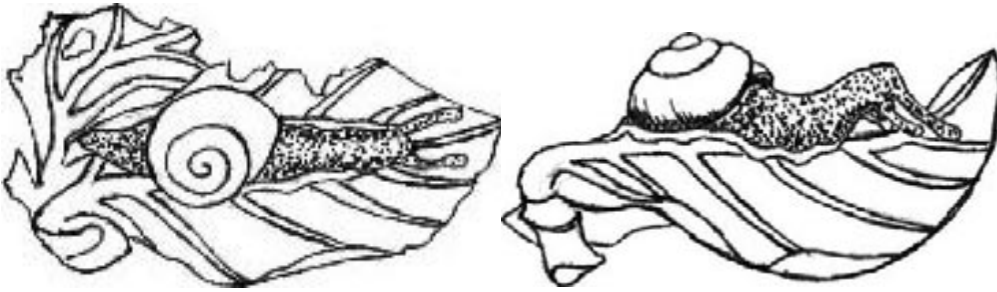

A really pretty design I saw in a netsuke book. This is a functional netsuke, originally used as a Japanese calligraphy brush rest. The snail's body in the original is textured with small, oblong gouge cuts, and is in natural-colored boxwood. The himotoshi is formed where the snail's head is lifted off the leaf, or where the leaf stem is separated from the leaf. In between the ribs, the leaf is also textured with small gouge marks. Be sure to make the leaf texture different from the snail's body.



A very compact design. The himotoshi is formed by a cavity beneath the snail's foot and the bottom of the shell. I plan to texture the snail's body with ukibori bumps. If you don't feel up to this, try texturing the body with patterns of small diamonds using an engraver, or small scoops with a gouge or rotary ball.

Netsuke - "Newborn" Hatching Alligator





Polychromed Whidbey Island Blacktail Deer Antler, with double-inlaid boxwood and Baltic amber eyes. American black walnut carved base. The himotoshi (cord holes) is hidden under the tail on the left side. By the way, "polychromed" (fancy art term for many colors) means I used Procion™ dyes for color. If I recall correctly, this was just a weak Procion™ dark brown solution. (2 $\frac{1}{4}$ "x1 $\frac{1}{4}$ "x1") Completed October 1997

## Netsuke: First Night Out



White-throated sparrow fledgling on a holly leaf, spending his (her?) first night away from home. The bird is of pyrographed (wood burned) and polychromed English boxwood with amber eyes, on an antler lid topping a desert ironwood bowl, with hippo tooth cord hole inlay. The ironwood bowl has a hippo tooth indexing peg that fits into a corresponding groove on the bottom side of the antler plate to prevent the assembly from spinning freely. 1 <sup>3</sup>/<sub>4</sub>" x 1 <sup>3</sup>/<sub>4</sub>" x 1 <sup>1</sup>/<sub>4</sub>" Completed December 1997

Netsuke - "Autumn's Beginning" Alder Leaf



Wilted Alder leaf in hippo tooth, with carved and fitted American black walnut display base. (2 1/2"x1 3/8"x1/2") Completed November 1997

**Netsuke: Chickadee and Pinecone**

Netsuke of young chestnut-backed chickadee on a pine cone, carved of pyrographed and polychromed English Boxwood. Inlaid amber eyes. American black walnut display stand and fitted tomobako.  
2" x 1 <sup>3</sup>/<sub>4</sub>" x 1 <sup>7</sup>/<sub>8</sub>" Completed March 1999

**Netsuke: Cloud Dragon**

This was my first truly complex netsuke. The dragon is carved from a piece of briar burl (like smoking pipes are made from), and the clouds are made from holly. If I recall correctly, the holly clouds are actually three pieces, individually carved to fit within the voids of the dragon, and glued together in the center. I didn't record the exact size, but it's about two inches in each dimension.



**Netsuke: Diving Helmet**

This was an interesting netsuke to make. It's carved of many pieces. The helmet itself was turned on the lathe in two pieces: the round head part, and the collar. Each of the portholes were lathe-turned from boxwood and amber, all the little valves and bolts on the collar are from ivory, and the octopus is carved from ivory with ink scrimshaw stippled color. To scrimshaw the ivory, I used a sharp pinpoint and poked tiny holes in the polished surface, then painted a red colored ink over the holes, and wiped it carefully off. The ink remained in the holes and provided the color.

**Netsuke: Haida Harvest**

Salmon and Dungeness crab in Native American style basket. Stained boxwood basket, stained hippo tooth crab with inlaid ebony eyes, Abalone shell salmon with double-inlaid hippo tooth/ebony eyes.  
(1 5/8" x 1 1/2" x 7/8") Completed July 1997

**Netsuke: Humpback Whale**

Humpback whale netsuke, carved of hippo tooth with inlaid desert ironwood eyes. American black walnut and boar tusk stand.

3 1/2" x 1 1/4" x 3/4" Completed December 7, 1998

Note: Stand fits under right pectoral fin, attaches to inside.

## Netsuke: Sea Nettles (two versions, ivory and horn)



Unstained hippo tooth ivory jellyfish with carved and fitted Horn jellyfish with steel and wood-  
 manzanita burl stand, fitted American black walnut stand. Stand, (3"x7/8"x7/8")  
 (2 1/4"x7/8"x7/8") Completed July 8, 1997

**Netsuke - Lizard on Mushrooms**

Anole lizard on two mushrooms and liverwort, carved of Whidbey Island Blacktail Deer Antler crown (naturally shed), with inlaid ebony eyes. Earthworm and two woodlice (aka roly polys or tumblebugs) on underside.

(1 3/8"x1 5/8"x1 3/8") Completed August 1997

**Netsuke: Praying Mantis on Pine Branch**

Whitetail deer antler sashi-style netsuke of a Praying Mantis on polychromed pine branch, mantis is natural antler color, inlaid horn pupil. French-fitted American black walnut presentation case, walnut display stand with steel pin. Pin fits in hole on underside of branch (not the himotoshi on upper branch end). (5 1/4"x2"x1") Completed July 18, 1997

**Netsuke: "The Old Ones Gather Firewood"**

I consider this to be one of my finest works. She won first runner-up to best in the world at the 1994 International Woodcarver's Congress in Davenport, Iowa. An unheard-of feat for something this small. Anyway, she's carved of English boxwood. A two-inch tall carving of a Native American woman collecting firewood, single piece with no inlays, and very tiny details like the lacing of her moccasins and torn skirt. The judges said her careworn face just looked old and tired.

**Netsuke: "Pitcher Thief"**

Fairly large for a netsuke at about three inches in diameter, I couldn't bring myself to cut down this magnificent deer antler crown any smaller. I took my inspiration from a college botany class field trip to a nearby Florida swamp, where I watched a small green treefrog raiding the dead insects in some pitcher plants. Simple inlaid ebony eyes.

**Netsuke: Yin/Yang Stingrays**

One of my first netsuke, and my first kagamibuta. If I recall correctly, the rays are cherry and boxwood, on a cherry bowl. The ojime is my first "ebony core" technique, using boxwood and ebony. About 1 1/2 inches in diameter.

**Netsuke: Fugu (Japanese Puffer Fish)**

Netsuke of fugu, carved of polychromed boxwood. Double-inlaid abalone and horn eyes, ivory lips. This fish inflates like a basketball when frightened, and is a great delicacy in Japan, even though extremely toxic if prepared improperly.  $2\frac{3}{4}$ " x  $1\frac{3}{8}$ " x  $1\frac{3}{8}$ " Completed February 2000

**Netsuke - "Belugas"**

Netsuke of three beluga whales, carved of hippo tooth. Inlaid horn eyes. A good example of multiple elements fitting within the netsuke "formula." Note how all the fins are wrapped around with no thin or sharp protruding parts.  $2\frac{7}{8}$ " x  $1\frac{1}{8}$ " x  $\frac{3}{4}$ " Completed July 1999

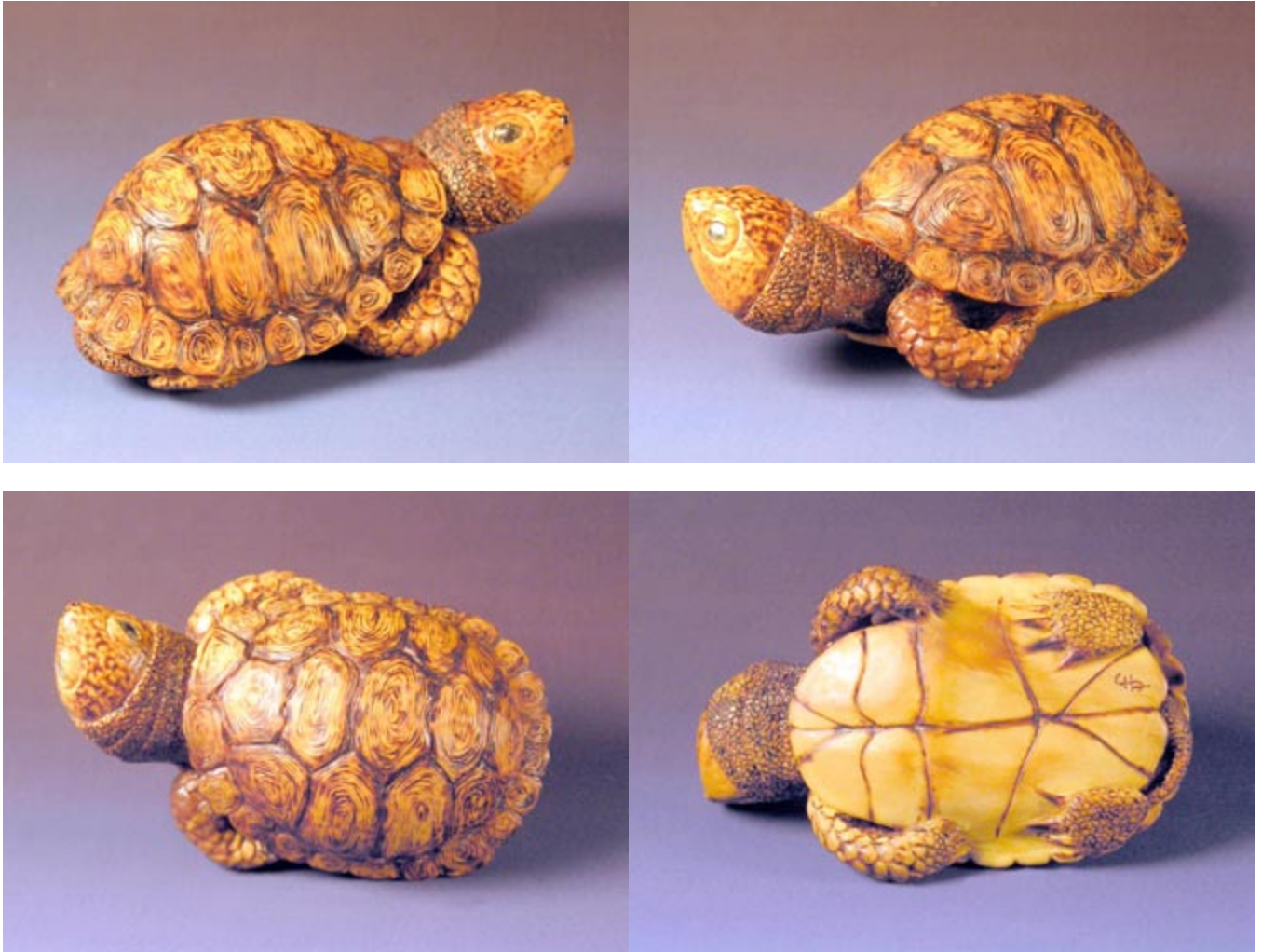

**Netsuke: Box Turtle**

Carolina Box Turtle carved of pyrographed and polychromed English Boxwood. Inlaid horn eyes. The scales on the legs were carved in a similar fashion to the wing feathers in the baby white-throated sparrow project, just a little bolder. I used the tiny stippling point of my woodburner to make the tiny round scales on the neck and feet, and the small knife point was used for texturing the plates of the shell. I used the flat of this same burner blade to color the mottled brown spots on the head.

2 <sup>3</sup>/<sub>8</sub>" x 1 <sup>1</sup>/<sub>2</sub>" x 1" Completed October 1999

**Netsuke: Brother Cellarer**





Drunken and slumbering monk carved of natural and pyrographed English Boxwood. His habit (robe) is stippled using the tiny stippling tip of the woodburner, and the small blade burner for the woven texture on the sandals and the barrel stays.

1 1/2" x 1 3/8" x 1 1/4" Completed October 1999

### **Netsuke: Bumblebee on Blackberry**





Another fairly complex assembly. The blackberry and the body of the bumblebee are from a single piece of ebony. The wings and yellow parts are boxwood, glued into prepared sites and then carved in place. The stem/leaves on the blackberry are another piece of boxwood. Carved mostly with small ball burrs, and minimal clean up with small chisels. About an inch long.

### **Netsuke: Calimari and Prawn**





Squid and octopi are two of my favorite subjects, and have appeared in a lot of my work, both within and outside the netsuke format. This one is of hippo tooth ivory, with abalone squid eyes, and black horn eyes for the prawn. The tentacles form a hollow basket. I used the stippled scrimshaw technique to color the body of the squid. This was prior to my Procion™ dye days. If I were to attempt something like this again, I would probably dye the body, using an artist masking fluid to preserve the white spots.

### **Netsuke: Chickadees in a Nest**





A trio of Mountain Chickadee fledglings in the nest. The birds are of pyrographed (wood burned) and polychromed English boxwood with amber eyes.  $1 \frac{5}{8}$ " x  $1 \frac{5}{8}$ " x  $\frac{7}{8}$ " Completed April 1998

**Netsuke: Cicada on Curled Leaf**





Netsuke of empty cicada shell on curled leaf, carved of polychromed boxwood. As a boy growing up in Florida, I always looked forward to the annual invasion of the cicadas when they emerged from their underground lairs. These paper-thin empty body shells were left on every tree, leaf, tall blade of grass, window and door screen while the adult cicadas sang from the tree tops. In years when there were especially heavy groups of emergers, the noise could be deafening.

$2\frac{3}{8}$ " x  $\frac{3}{4}$ " x  $1\frac{1}{8}$ " Completed April 2000

**Netsuke: Dragonfly Kagamibuta**

One year at a netsuke convention, I obtained a few pieces of a deep water coral branch. I made the bowl of this kagamibuta netsuke from that, and added a lid of pyrographed boxwood. The hole in the bottom of the bowl is lined with ivory.

**Netsuke: Celadon and Porcelain Crab Kagamibuta**

Kagamibuta netsuke of porcelain crab in celadon glaze, moose antler bowl.

1 1/2" x 1 1/2" x 3/4" Completed November 2000



**Netsuke: Smoke-Fired Porcelain Crab Kagamibuta**

Kagamibuta netsuke of porcelain crab with triple fired, smoked finish, yew wood bowl.  
1 1/2" x 1 1/2" x 3/4" Completed November 2000

Netsuke: "Spring Phlox" in the Snow



Phlox in spring snowbank, polychromed hippo tooth (Procion™ dye).  
(1 1/2"x1"x5/8") Completed January 1998

**Netsuke: Crab in an Oyster Shell, with Oyster on the Halfshell Ojime**





The tiny purple shore crab (a local beach crab here on Whidbey Island, Washington) is carved of stained boxwood, and is glued and pegged (tiny ivory pegs) into a deer antler oyster shell. Several little ivory barnacles make up the himotoshi (cord holes). The oyster on the half shell ojime is of deer antler and holly.

**Netsuke: Dead Duck Decoy**

I carved this guy as a joke. I was hanging around a bunch of bird carvers who were harassing me to try carving duck decoys, so I did. Duck decoys have a little keel attached on their bottoms to make them float correctly. The dead duck decoy is carved from boxwood, with an accurate half-scale shotgun shell ojime of boxwood and Mayan bloodwood. About two inches long, Completed in 1995.

**Netsuke: Entwined Fate**

I carved this netsuke at the height of the tuna/dolphin netting controversy. Carved from a three inch long piece of sambar stag antler. The nicest antler I've ever carved, very dense and white, with very porous and interesting marrow core.

**Netsuke: Tree Frog on Mushrooms**



Netsuke of a tree frog on mushrooms, carved of hippo tooth with double-inlaid amber and boxwood eyes.  
2" x 7/8" x 7/8" Completed December 1998

**Netsuke: Wormy Garlic**

Netsuke of a wormy garlic, carved from holly with deer antler and ebony worm. Another humorous piece designed to make the viewer stop and reflect on the vagaries of life. About 2 1/2 inches tall.

**Netsuke: Wormy Pepper**





Netsuke of a wormy pepper. Must have been in my wormy phase at the time. It's carved from a small pine burl I picked up on a family reunion in northern Alabama. I use it here to illustrate that you should always be on the lookout for carving material. Any odd shape of material can be used to produce a novel netsuke if you keep an open mind and a sense of humor.

### Netsuke: Hermit Crab

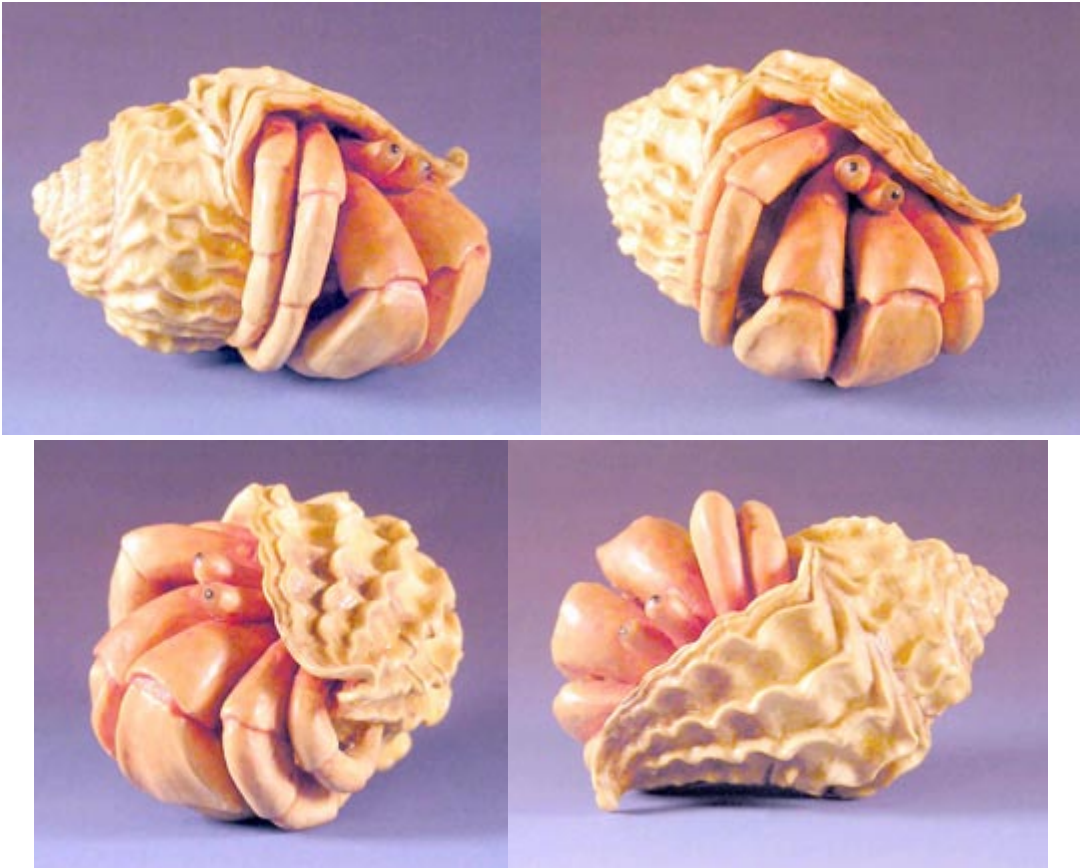

Netsuke of hermit crab, carved of polychromed boxwood, double-inlaid eyes of ebony and horn.  
2" x 1 $\frac{1}{2}$ " x 1 $\frac{3}{8}$ " Completed April 2000

**Netsuke: "Fall of Maple" Intro, Netsuke and Ojime Suite**

Matched set of netsuke, ojime and single case intro. Netsuke is carved of pyrographed and polychromed English boxwood and Washington (the state) vine maple burl, with representation of alder and vine maple leaves. Ojime is of fossil walrus ivory and vine maple burl. Intro is carved of pyrographed and polychromed Washington Vine Maple Burl. About 3 inches in diameter. Completed November 1998

Netsuke: "Sizing Up" - Golden Crowned Kinglet





Sashi style netsuke of a Golden Crowned Kinglet and Swallowtail caterpillar. Carved of pyrographed and polychromed English Boxwood. Inlaid amber eyes Vine Maple burl stand, American black walnut fitted tomobako.

1" x  $\frac{7}{8}$ " x 4" Completed May 1999

## Netsuke - "Kraken and Leviathan"



Netsuke of sperm whale and giant squid, carved of polychromed boxwood, double-inlaid eyes of fossil ivory and horn.

$1\frac{7}{8}$ " x  $1\frac{3}{8}$ " x  $\frac{7}{8}$ " Completed March 2001

**Netsuke: Woodworking Plane**





### **Netsuke - "After Tomochika"**

A copy of an 18th century English woodworking plane, carved in English Boxwood, Desert Ironwood and hippo tooth. To scale and all moving parts are removable and fully operable.

2 <sup>3</sup>/<sub>8</sub>" x <sup>5</sup>/<sub>8</sub>" x 1 <sup>3</sup>/<sub>8</sub>" Completed October 1998

The inspiration for this piece came from an unusual netsuke by Tomochika in the Avery Brundage collection in the Asian Art Museum (San Francisco), a 19th century netsuke of a Japanese style woodworking plane, carved in stained ivory.

**Netsuke: "Puget Sound Symphony" or "Wishful Thinking"**

Mussels on a rotted piece of driftwood from my beach, carved in deep water coral. Antler starfish inlaid with pink coral spots. Ivory barnacles. I was completely entranced by the outer surface of the coral, so I left it as I found it.



**Netsuke: Washtub Pumpkins**

Just a fun piece for Halloween. Boxwood pumpkins, osage orange washtub, with boxwood rings, and boxwood hollow ojime jack o'lantern. I chose the osage orange (also known as bois de arc, hedge apple) because I'd never carved any. Had the oddest bright fire engine green/yellow at first, then rapidly faded to

the color seen here. Chippy, with a fairly coarse grain. I wouldn't really recommend it for netsuke.

**Netsuke: Pygmy Owl**





Netsuke of a Pygmy Owl and Clark's Sphinx Moth. Carved of pyrographed and polychromed English Boxwood. Triple-inlaid amber/ebony/boxwood eyes. A friend took me with him to see this guy in the flesh at a local hawk and raptor recovery group. He (she?) had been injured and was being nursed back to health for eventual release back into the wild. I actually got to hold him while photographing. He was no bigger than my fist, and was as heavy as a brick. The folks there told me he was the boss of the place, and his fearless attitude really did show. These little fellows are the smallest of the owls, and they aren't nocturnal, hence their small eyes. Not uncommon in my neck of the woods, but almost never seen. Most people just assume they're some sort of small songbird, never realizing they're the toughest little Napoleans of the owl world.

$2\frac{5}{8}$ " x  $1\frac{3}{8}$ " x  $1\frac{1}{2}$ " Completed July 1999

## Netsuke: Seahorses

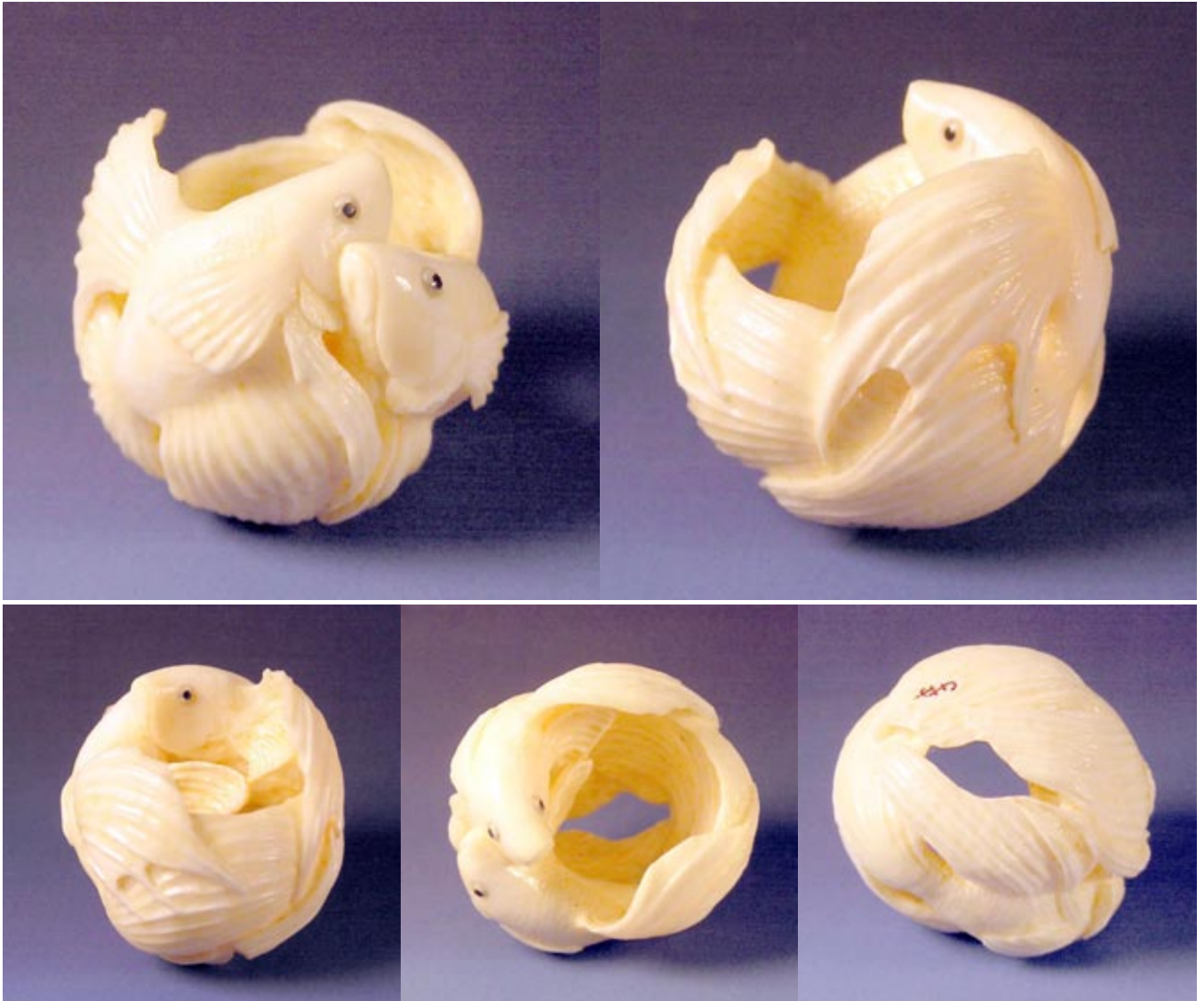

Netsuke of male and female seahorses. The male is the pregnant one - my wife says Mother Nature finally got it right. Pyrographed and polychromed boxwood, ivory and ebony double-inlaid eyes. About 2 1/2 inches tall.

**Netsuke: Siamese Fighting Fish**

Netsuke of two male Siamese Fighting Fish, carved of hippo tooth. Double-inlaid fossil walrus ivory and horn eyes.

1 $\frac{1}{4}$ " x 1 $\frac{3}{8}$ " x 1 $\frac{1}{4}$ " Completed July 1999

**Netsuke: Sockeyes**





### Netsuke - "Sockeyes"

A pair of Sockeye salmon, in spawning colors on gravel river bed. Carved of polychromed English boxwood with double-inlaid eyes of hippo tooth and ebony, salmon roe inlaid in pink and red coral. American black walnut tomobako.

1 1/2" x 1 1/2" x 7/8" Competed August 1998

### Netsuke: Spanish Dancer



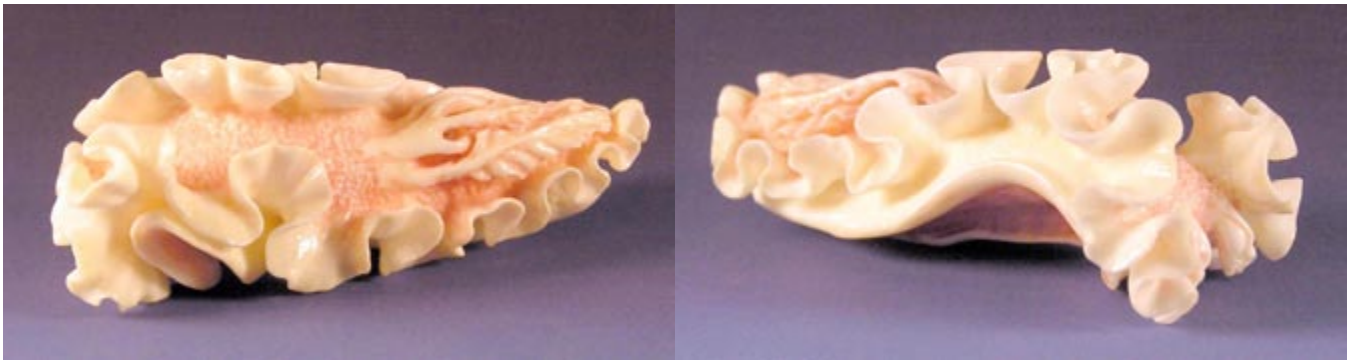

### Netsuke - "Spanish Dancer"

Netsuke of "Spanish Dancer" nudibranch (shell-less marine snail), carved of polychromed hippo tooth ivory.

2½" x 1" x 1" Completed March 2001

### Netsuke: Twins





**Netsuke - “Twins”**

Walrus katabori netsuke, carved of unstained fossil walrus tusk (hence “Twins”), with Desert Ironwood inlaid eyes.

1 1/4” x 1 1/8” x 1” Completed June 1998

**Netsuke: Golden Orb Spider**

Netsuke of a golden orb spider carved of boar’s tusk. Polychromed, with ebony inlay.

3 3/4” x 1 1/8” x 1/2” Completed February 1998

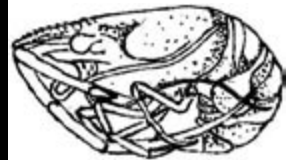
**Netsuke: Shrimp****Shrimp Front and Back views**

This shrimp I made for a necklace, and about 75% size of this pattern. I only carved the front half, and left the back flat, with some enamel left on the back half. I removed the thick (and hard!) enamel from the front half by soaking the slice of tooth in shallow muriatic acid, only as deep as the amount of the enamel I wanted to remove. This took about 30 minutes. I debated whether to leave the ivory white, or to put some ink-darkened scrimshawed stippling on the shell. I settled on white. I think this would look good in a light-colored wood as well.

***Ojime*** - Ojime are the little beads strung on the string between the intro and the netsuke. They're used to snug the intro drawers closed. The following ojime are a few of my versions.

**Ojime: Cicada**



.999 fine silver cicada ojime. I created this ojime from a new material called Precious Metal Clay. It's particles of pure silver in an organic binder that works like clay when wet, then is fired once it's dry at about 1700 degrees F in a kiln. The binder burns away and the particles of silver sinter (melt together), leaving solid metal. Sure beats lost-wax casting for one off designs! There's about a 25 percent shrinkage factor, which in the netsuke world is a real boon. You get to work in a larger size and end up with a smaller one. Works for me! About 1/2 inch long.

Ojime: Frog on Branch



.999 fine silver (Precious Metal Clay) tree frog on a branch ojime. About 3/4 of an inch tall.

**Ojime: Fugu**

.999 fine silver (Precious Metal Clay) fugu (Japanese puffer fish) ojime. A nice feature of Precious Metal Clay is you can form a shape around a core that will burn away during firing, leaving a hollow shape. This ojime is quite light, being hollow. Uses less material, as well. About 3/4 of an inch tall.

**Ojime: Ladybugs**

**Ojime - “Ladybugs”**

Polychromed hippo tooth ladybugs with inlaid ebony spots, stag antler core (a fairly spongy piece) with ebony sleeve bark. Turned American black walnut stand.  
(1”x5/8”x5/8”) Completed Aug 1997

**Ojime: Octopus**



.999 fine silver (Precious Metal Clay) octopus on a silver tube ojime. About 3/4 of an inch tall.

### Ojime - "Cherry Blossom Viewing"

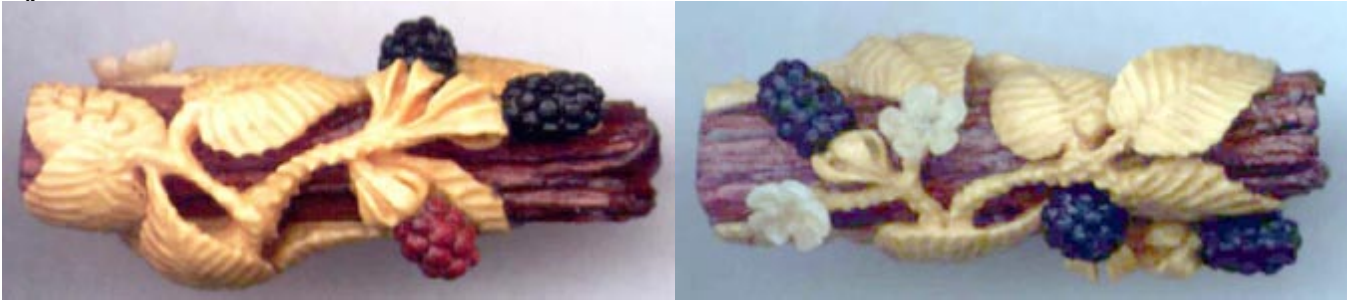

Stag antler core with boxwood liner, natural finished boxwood cherry tree and, hippo tooth flowers. "Ebony core" technique. (7/8"x1/2"x1/2") Completed July 1997

**Ojime: Blackberries**

Blackberries and flowers ojime carved from kingwood (core), ebony and Mayan bloodwood berries, ivory flowers. "Ebony core" technique. About 3/4 of an inch long.

**Ojime: Sea Nettle**

Sea nettle (jellyfish) ojime carved from hippo tooth ivory, ebony (core), . "Ebony core" technique. About one inch long.



**Ojime: Spider and Web**

Spider and web ojime. Amber spider, hippo tooth web, ebony (core). "Ebony core" technique. About one inch long.

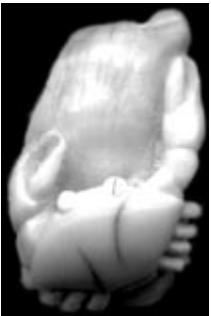
**Miscellaneous Carvings**

This is a little crab I carved out of an elk's tooth. Elk (the North American version, not the European, which is more like a moose) have two incisor(?) teeth that are ivory. This one came from a winter-killed elk I found in the woods on a fishing expedition. About 1/2 of an inch long.



This is a lizard on an oak branch I cast in silver. Made with the lost-wax casting method, it made a nice necklace, and would make a nice looking carving in wood.

### *Inspiration Pages*

The following selections of antique “real” netsuke are provided as inspiration. They are all good subjects for carving practice. Those with comments are some that I have information on. Others are simply pictures of museum netsuke that I liked and felt would make good carving subjects. Unfortunately, I didn’t record their information. Good carving, and good luck.

#### **Ox, by Ryuun 19th Century**









This little dark wood ox is my favorite netsuke. It's the most realistic little thing you've ever seen. The hair is tiny parallel lines engraved on the surface, and the hanging skin under his throat really makes this piece. It's certainly a shame you can't see this one in person.

Here's my version. Rather than make a direct copy, I added my own little spin to the creation by turning it into an American Bison (buffalo). I titled it "Matriarch" after a huge momma buffalo we watched in Yellowstone National Park, lying placidly on the grass while her young calf ran and played around her.













This last picture is of the original Matriarch (on the right) along with a bronze lost-wax casting a friend made. This is a method of producing multiple (and perhaps saleable) items from one original. Just something to keep in the back of your mind.



Here is Ox and "Matriarch" side by side.

Goat, unsigned 20th Century





This ivory goat is a 20th century piece, so those in the know tell me. Its double-inlaid eyes are quite nice, with dark pupils inlaid into amber. The hair is in long, rounded clumps; a good technique to remember for woolly animals without that smooth-coat look. Animals like this, especially in this pose are quite common in netsuke.

**Rat on Lotus Root, unsigned Late 18th or Early 19th Century**









An excellent carving using stag antler, and fairly large as netsuke go. It is of a rat on a cut piece of lotus root. You can see the porous interior of the antler in the dark area of the rat's back. Stag antler is definitely a challenge. It is such a limited material, available only in relatively small sizes, and only one basic shape. Whoever carved this one did very well. About 3 1/2 inches long, unusually large for a netsuke.

**Monkey, Unsigned 19th Century**



Feisty little monkey, carved of boxwood. About 1 1/4 inch tall.

**Tiger and Monkey, by Ran 19th Century**

Yes, they really are carved on all sides! A neat piece in ivory, with nicely incised hair, and expressive faces. Note the artist's signature in the oval area on the tiger's flank. About 1 1/2 inch long.



**Tiger, unsigned 18th Century**

Here's a really tough-looking ivory tiger. He reminds me of our family cat, Sam, now passed on. Many antique tiger netsuke really look like house cats, because the old netsuke carvers didn't have access to real tigers, only descriptions and paintings. This would be a good subject for a novice carver. Note how the artist defined the tiger stripes on the side. The dark stripes are outlined and left blank, and the space in between is textured with incised hair lines. Note the age cracks in the ivory on the rear flank of his hind leg. About 2 inches long.

**Tigers, unsigned 19th Century**



Mother and baby tigers. Note the fur and stripe textures.

**Sea Horse, unsigned 18th or 19th Century**

A stag antler sea horse. This netsuke gains much of its charm from its many worn spots and nicely polished patina. It's also a simple design that should be easy for novice carvers.

**Centipede on Rock, unsigned 19th Century**

This netsuke is of a reddish amber. A good example of one of the many materials netsuke were successfully made of. The rock is textured with small triangular chisel marks.

**Snail on Grape Leaves, Ryusa-style manju, unsigned 19th Century**

A really spectacular piece in person. Made of stag antler, the rough texture of the spongy antler marrow really enhances this one. All detail is in low relief or outlined by the pierced holes. The interior is completely hollow, and the back is of extremely porous antler marrow, with large holes.

**Hawk on Pine Bough Manju, unsigned 19th Century**

A nice example of multiple inlays called shibayama (named for the artist who developed the style). All detail is actually carved below the surface of the ivory body. The pine foliage is of tiny radial cuts, darkened with ink. The body is of ivory, and the wings and beak are inlaid in horn or tortoise shell. The tiny round dots in the pine foliage are tiny pieces of semi-precious stones.

Blind Men on Plank, by Ikkosai 1830 - 1843





Well carved ivory netsuke. Note the patterns carved in the second man's shirt. All the details are darkened with ink.

**Dancer, by Minkoku 1789 - 1800**





A really exceptionally expressive ivory netsuke, and very nicely polished. All the details are darkened with ink. Note the expression on the dancer's face; expressiveness is one of the endearing qualities of good netsuke. This piece balances on one foot.

### **Robber on Log, unsigned 19th Century**



Another of my favorites. This ivory netsuke reminds me of people I've worked with. Note the friendly look on his face, and the club behind his back. Subtle humor is often a characteristic of many netsuke. Of course, many have a sense humor that is earthy, or sometimes lost on Westerners.

**Wise Man with Scroll, unsigned 18th Century**

This is a very old piece, with most of its ivory details worn off through use. Even so, it is very expressive and has a wonderfully smooth feel and golden glow. It's so smooth and worn that I can imagine its owner using it like worry beads.

**Gamma Sennin, unsigned 18-19th Century**





Carved from antler, quite simple, but elegant. Note the expression on the sennin's (wise man) face, and how the leaves of his cloak are carved. Sumi ink darkens the line cuts.

### Root netsuke, unsigned 19th Century



A piece carved from a root with wildly swirling grain. Even in ancient times, woodcarving was a hobby. This is a piece often described as farmer's art. Since netsuke were such popular accompaniments to Japanese dress, this one was probably either carved for sale at the equivalent of a Japanese craft fair, or was carved by a hobbyist for his personal use.

Pea Pods



Several pea pods carved in ivory, very realistic. Netsuke subjects can be very simple, yet very effective.

**Frog and Basket**

Nice frog carved from vegetable ivory (tagua nut). Note the crack and void on the bottom - tagua nuts almost always have a small, irregular void in the center. Be aware of this if attempting to carve one.

**Okimono:**

No discussion of netsuke carving can go on without mentioning a related art of okimono carving. Okimono are decorative carvings like netsuke, only larger and not intended to be worn.

**Basket of Fish Okimono**

Carved of elephant ivory, about 3 1/2 inches tall. I've disassembled this one, and it looks like the inside ivory removed from carving the basket were used for the fish. There is a wooden plug in the bottom to raise the interior carvings so they rise above the top edge of the basket.

## Quail Okimono



Carved from some sort of wood knot, perhaps boxwood. There is a natural void inside the birds that is concealed by the slice of ivory on the bottom. Quite polished and worn, so I imagine someone lovingly fondling this piece over and over, perhaps for generations.

## Miscellaneous Items: Not Necessarily Netsuke

### Polymer Clay Press Molds with Precious Metal Clay

With the advent of new high-tech materials like Precious Metal Clay (PMC) and polymer clays, the artist has the option of producing combinations of simple molds and press castings to produce multiple copies for use with small carving projects. Here is a sampling of how I've been using both of these materials, largely eliminating my need for lost-wax castings and reducing the amount of expensive and dangerous equipment.



I begin by carving the master model. Here, I've used my computer to scale a scanned profile image of a stag beetle, and then rubber cemented the printed image onto a block of boxwood of appropriate thickness.



I've drilled holes in strategic spots so my scroll saw can conveniently cut out the profile. If you don't have a powered scroll saw, a jeweler's saw or coping saw with narrow blade will suffice.



Here's the profile cut out.



Here's the finished wooden master, and a flat piece of wood I'll glue the master beetle model onto.



Here's the finished wooden master, mounted on a flat piece of wood, and below is the polymer clay press mold. Follow the directions for the brand of polymer clay you have for softening the clay. Then, roll out a thick, flat section that is larger than the master model, and press the clay over the master. I used cooking starch to dust the clay with (as a separating agent so the clay won't stick to the model) prior to pressing it onto the master model. Trim and bake according to the manufacturer's instructions.



Shown in this photo is the first press casting of the PMC (the gray beetle below the light colored wood model). I coated the polymer clay press mold with olive oil so the PMC clay wouldn't stick. Then I rolled the PMC into a thick sheet, a little thicker than the depth of the polymer clay press mold and pressed it into the void with my fingers, then used a small plastic cylinder as a rolling pin to make sure I got the PMC into every small detail. Using a small sharp knife, I trimmed away any



excess clay around the edges. Here's a trick for getting the PMC out of the polymer clay press mold: taking a small piece of newspaper, I laid it over the PMC and rolled it once more with the plastic rolling pin. The paper sticks to the clay, allowing you to easily peel the clay out of the polymer clay press mold without damaging it. I then use small tools to clean up any small problems, and place the PMC on an unglazed ceramic tile and place it into a 175 degrees (F) kitchen oven for several hours to dry. Incidentally, this is the original type of PMC, not PMCplus or PMC3.



Once it is dry, I peel the paper off and use my smallest diamond burrs to carve any extra details or cleanup into the hardened PMC. Above is the unfired PMC beetle, cleaned up, detailed and ready for firing. I fired the PMC in a small kiln (mine has a digital controller - highly recommended! Spend the extra money and make your life far more pleasant!) at 1650 degrees (F) for 2 hours.



Above is the fired (and cooled) PMC beetle just out of the kiln. Note how dull and gray-white it looks.



Here's the same PMC beetle, burnished and polished.



I've used a silver blackening liquid to blacken the silver, then polished the surface. This leaves the raised areas bright silver, and the sunken areas black for greater contrast. Really makes the details pop out.



Here's the part of the real beauty of this system. I made another polymer clay press mold from the first PMC beetle I cast and fired. Original PMC has a 25 to 30 percent shrinkage factor. You can see the dramatic differences above. The wooden master is the original size, and the size of the void in the first polymer clay press mold. The top silver beetle was cast in the first press mold and has shrunk in the first firing. The last (and smallest) beetle is cast and fired from a press mold made from the first silver beetle.



Here are the original model, the first cast and fired beetle, and two smaller beetles cast from the second press mold. Thanks to this shrinkage factor that traditional jewelers sometimes think of as a nuisance, you can work in a larger size and end up with smaller sizes at the same level of detail. Ain't technology wonderful?

## Carving Porcelain Netsuke



Perhaps the easiest method of teaching porcelain netsuke carving is with a small ceramic press mold. This removes a considerable amount of both guesswork and eye-hand coordination from the project. A press mold is a simple cavity where wet clay is pressed (hence the name), allowed to dry briefly, then removed, leaving the clay in the shape of the original model. In this example we'll be using a spider carved on the top cap of a small mushroom.

**A word about Models** - Models should be simple and without undercuts. Press molds can achieve fairly decent detail, but the results will require a fair amount of "cleaning up." The example used here was chosen for simplicity. The cap and spider of the mushroom is produced in the press mold, leaving the underside to be detailed, and the stem to be fabricated by the student. This leaves a reasonable amount of work to be done for learning purposes, but also provides a reasonable assurance of success.

**Materials Needed:**

- Simple Model
- Fine-grained soft clay (no grog)
- Board with large hole or holes (mold board)
- Scrap piece of board
- Long bladed knife (Fettling knife works well)
- Nonstick cooking spray
- Newspaper strips, cut to the width of the mold board
- Access to a ceramic firing kiln

**Model - The top of the mushroom cap****Model - The bottom of the mushroom cap**

**Creating the Press Mold:**

Prepare the mold board by drilling or cutting a hole or holes. The holes need to be large enough to contain your model with at least half an inch to spare around the model. Line the holes in the board with the newspaper strips. It's handy to use the edge of the mold board and a sharp X-acto knife to cut through several stacked sheets of newsprint to make them the thickness of the mold board. Without the newspaper strips, the clay will stick to the board and you won't be able to remove the finished press mold! The mold will crack if left inside the board to dry.



**Mold Board - holes lined with newspaper strips.**

Place a small ball of clay in each hole, inside the newspaper strips. The board shown here has holes two inches in diameter, and took a ball of clay about the size of a golf ball to adequately fill the holes. Using the scrap of board, press the clay well into the holes. Using the fettling knife, cut along the top of the board to level the clay. It's important to do this step now, since pressing the clay model into the surface will cause the clay to overflow the top of the holes. Don't worry if the clay in the holes pulls away from the edges. When we press the model into the clay, the holes will fill back up. Just make sure not to let the knife pull the newspaper strips out.

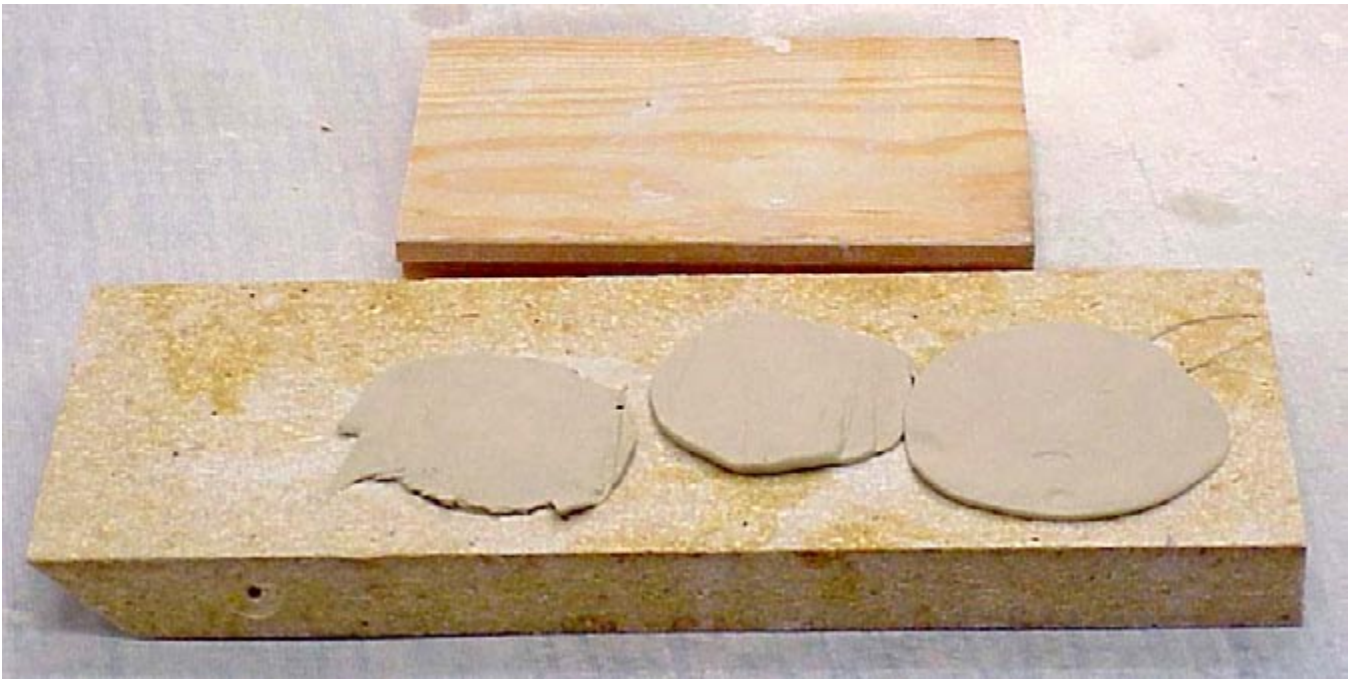

**Mold Board - holes filled with clay, forced into holes with board scrap**

Use the nonstick cooking spray to coat the surface of your model (the surface that will come into contact with the clay). We don't want the clay to stick to the model. Sticking will destroy the mold when the model is removed. Press the model into the clay. The "top" edge of the model should be down in the clay and level with the top edge of the mold board. The clay will overflow up over the top of the board. Use the fettling knife to trim off the extra clay down to the "top" level of the model.



**Mold Board and fettling knife - trimming the clay-filled holes flat**

Now, remove the clay and model from the mold board. If the newspaper strips weren't disturbed when you trimmed the excess clay off, the model and the clay should come out easily. Once removed, carefully pull the model out of the clay. You should pull straight up. If the model is pulled out at an angle, you'll alter the mold you're trying to make.



**The model and prepared clay, ready for pressing**



**Model pressed into the clay, trimming with the fettling knife**





### **Model pressed into the clay, and trimmed**

When the model comes out of the clay, it will probably pull the edges of the clay up with it, leaving a small ridge around the edge of the mold cavity. Rather than leave this sharp edge on (which will be both sharp and hard after firing), use a finger to smooth it outwards around the edges.

Let the mold sit until completely dry, probably at least four days. Be sure to put them on a surface where dampness will not damage anything, and (most importantly) where they will not stick, or they will crack. A few sheets of newspaper or a piece of cloth will keep them from sticking. Typically, I set mine to dry on a clean, unglazed tile (available from ceramic supply or building supply stores). The tile absorbs water a little more quickly and speeds the drying.

Once fully dry, fire them in a ceramic kiln somewhere between cone 08 to cone 04. It may be helpful to “candle” them for several hours (kiln on low to make sure they’re completely dry) before beginning the high-temperature firing. It’s important to only “bisque” fire the molds. This leaves the mold porous, so it can “pull” water out of the clay pressed into it, shrinking the clay so it can be released from the mold.

### **Creating a Ceramic Netsuke**

Now we’re ready to begin using the press mold we just made. We’ll begin with a medium fire porcelain clay, without any additives like grog (pre-fired, ground-up pottery added to strengthen the clay). We don’t want grog or similar additives because we’ll be carving the porcelain, and grog acts like boulders in the way of the knife or scraper.



### Materials Needed:

- Press Mold - (preferably one per student)
- Medium fire (for example, Cone 6) fine-grained soft porcelain clay (no grog)
- Long bladed knife (Fettling knife works well, may be shared by several students)
- Small bent and pointed scraper - (one per student)
- Small pointed brush - (may be shared by several students)
- Slip made from the clay you'll be carving (about the consistency of yogurt)
- Paper or plastic cups, one for clear water (brush washing and clay smoothing), one for slip - (these may be shared by several students)
- Small square of cardboard or wood scrap - a place for the netsuke to dry with a minimum of handling (one per student)
- Newspaper to cover work surface, paper towels for wiping brushes, students, work area, spills, etc.
- Access to a ceramic firing kiln

**Making slip** - you can make slip from the clay you'll be carving simply by adding water to the clay. You may find it easier if you cut the clay into flat strips 1/8 to 1/4 inch in thickness and allow them to air dry. Place them in a wide-mouthed jar or plastic butter tub and pour water over them. Allow them to stand at least for several hours, then pour off the excess water. Stir the mixture until smooth and the consistency of yogurt. Add more water if needed. If the slip is too thin, let stand overnight again and pour off the standing water once the clay has settled out. Once the slip is the consistency you need, cover tightly to store.

Begin the netsuke with a small ball of soft porcelain clay, about half the size of the cavity in the press mold. Place the ball in the **DRY** press mold, turn the mold and the clay ball upside down and press hard on a **solid surface covered with newspaper**. If you omit the newspaper the clay may stick to the surface and be difficult to remove without ruining the pressing.



The ball of clay in the press mold. This ball is actually too large. Half this size would work better.



The press mold upside down, preparing to press against the table top.



After pressing against the table top, excess clay squeezed out from beneath.

The excess clay will squeeze out from beneath the upside down press mold. Now taking the long knife (it doesn't have to be sharp), start in the center of the clay and scrape to one side. This will remove the excess clay that squeezed out during pressing. We need to start in the center, because if we start at an edge and go all the way across, the pressing will deform. Once half is done, turn the mold around and scrape the other half. Should the pressing deform a small amount, simply press with the thumb to spread the clay out completely into the mold cavity.



Half of the excess removed with a



All of the excess removed with a fettling knife. Note the pressing is not deformed.

Bisque fired and **DRY** press molds remove water from soft clay very quickly. As the water is removed from the clay, the clay will shrink, pulling away from the sides of the press mold. Once you can see a small

crack running all the way around between the clay and the press mold, gently tap the press mold upside down (clay side down) on the table top. The clay pressing will fall out.

Once the mushroom cap and spider pressing is successfully removed, we need to add the stem of the mushroom. We'll do that first by taking a little bit of clay and rolling it on a smooth surface to make a long roll. Think about what the stem of a mushroom looks like, or better yet, have some resource material handy with pictures of mushrooms. In the case of mine, I've left a large rounded end to resemble the part of the mushroom that contacts the ground.



**The top of the mushroom cap as it looks removed from the mold.**



**Depression cut into the bottom surface of the mushroom cap**

Using the scraper, cut a small depression in the bottom of the mushroom cap. This is where the stem will be attached to the cap. **Be careful not to damage the spider on top of the cap!**

Trim the stem/roll to length, then bend the stem into a spiral. This is to follow the netsuke formula rules of not having any delicate protrusions. I've left a small open space through the center of my spiral to form the himotoshi (the cord holes). Since netsuke aren't worn very often anymore, you do as you please. If you want to include the holes, you might find it handy to bend the stem around some small rod. Fit the stem to the cap, and make any adjustments that are necessary. Keep fitting and adjusting until you're satisfied with the fit.



**The stem rolled into a spiral. Notice the surface cracks in the quickly drying clay.**

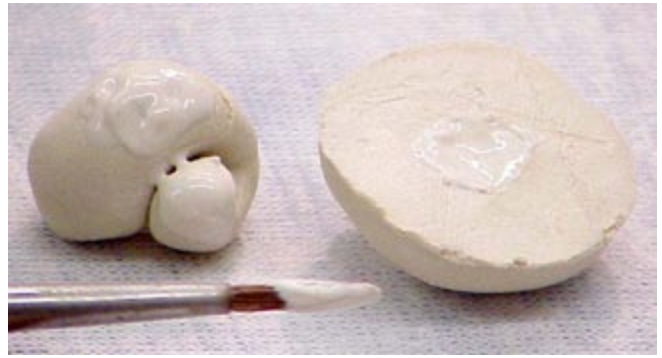

**Slip applied to the end and bottom of the stem, as well as the depression in the cap.**

Small cracks may appear on the surface of the stem as you bend it. These are caused by rapid drying of the surface of the clay. Don't worry about them, we'll fix those shortly.

Using the small paintbrush, apply slip to the stem where it will attach to the cap, and whatever portion of the spiral will touch the surface of the cap. Also apply slip to the depression in the cap. **Use plenty!** Think of slip as the "glue" for clay. The slip will make sure we get a good bond between the stem and the cap.



**The stem attached to the cap.**



**Two views of the mushroom cap with the stem attached.**

Let's fix the surface cracks on the stem now, if you have any. We'll do this by painting thick layers of slip into and around the cracks with the small paintbrush. Once this dries, we won't be able to tell the difference from the slip and the original clay. Keep this in mind as you work on this project. Slip can correct a lot of problems by simply painting it onto damaged areas. Remember that it may take more than one application, or simply use it to glue a little more clay onto a trouble spot. Not only that, but towards the end I'll show you how to further embellish your creation using slip applied with a paintbrush.

While I was attaching the stem I was also manipulating the mushroom cap to make it a little more pleasing looking. As we remove the cap from the mold, it is a perfect shape which is seldom seen in nature. I bent an edge of my mushroom cap up and several others down to make it look more natural. This is your opportunity to change the design to suit yourself. Let your creativity loose!

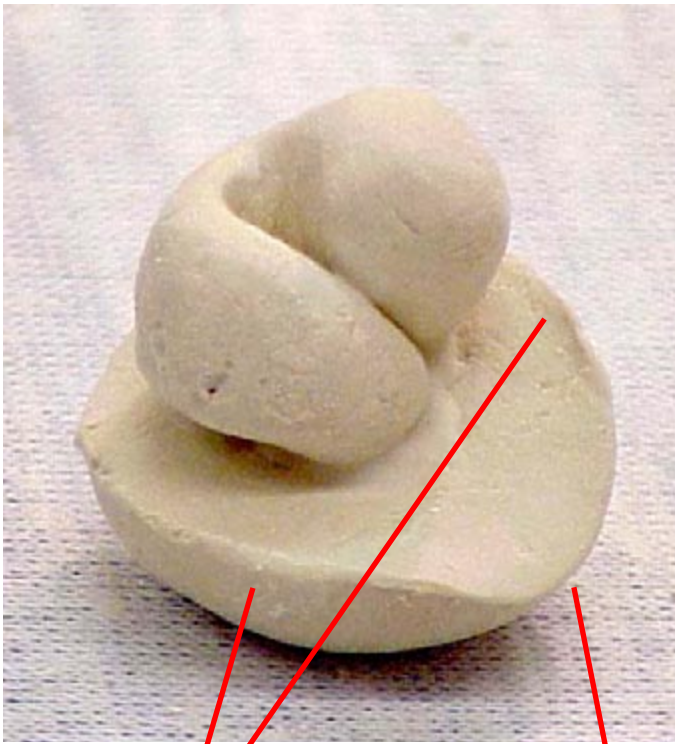

**Edges of the cap  
turned down**

**Edge of the cap  
turned up**

This is probably a good time to quit for the day. The clay is too soft to carve at this point. The clay needs to get to a stage called “leather hard” in order to carve easily. At the proper state, porcelain carves almost like soap. As it gets harder, it scrapes more than slicing soap shavings, but can be easily carved even when totally dry. However, when the clay is too soft, you’ll just do more damage than good. Let’s set the piece aside at least for several hours, preferably overnight to harden.

Now that the clay is “leather hard” or harder, it’s time to begin carving. We’ll be refining the stem, adding the gills on the underside of the cap, cleaning up the spider, and of course, adding our signature. To do all this we really only need the scraper tool, clean water, slip and a paintbrush.

Start by carving a circle in the clay on the underside of the mushroom cap, perhaps 1/16 of an inch from the edges. Start lightly until you get the feel of the clay. If you carve too deeply, you run the risk of cracking the clay and losing a portion you didn’t want taken off. If this happens, don’t panic; if it’s a large piece, just save it and glue it back on with plenty of slip. If it’s a small piece, just use the paintbrush to fill the crack and any holes with slip. With the clay as dry as it is, the slip you add will be dry in just minutes.

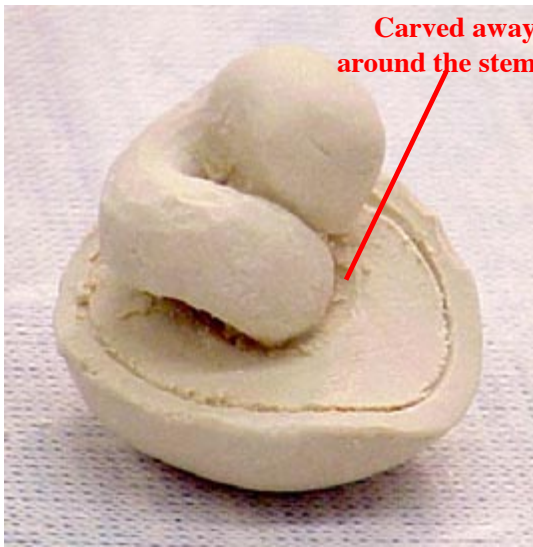

The circle carved along the edge of the underside of the mushroom cap and around

Next, carve away some of the clay around where the stem enters the underside of the cap. We eventually want to make a smooth curve from the stem to the outer circle so the gills will sort of bulge out. Remember, something in nature that looks flat is rare and has an unnatural appearance. Begin carving, gradually and gently, until you have deepened the outer circle and carved a gentle slope down to it. You'll also have to clean up the area on the outside of the circle to the edges. We'll want the edges gently rounded, with no sharp edges.

Clean up the stem and carve away any areas that don't look right. Now is also the time to clean out the "himotoshi" (cord holes).

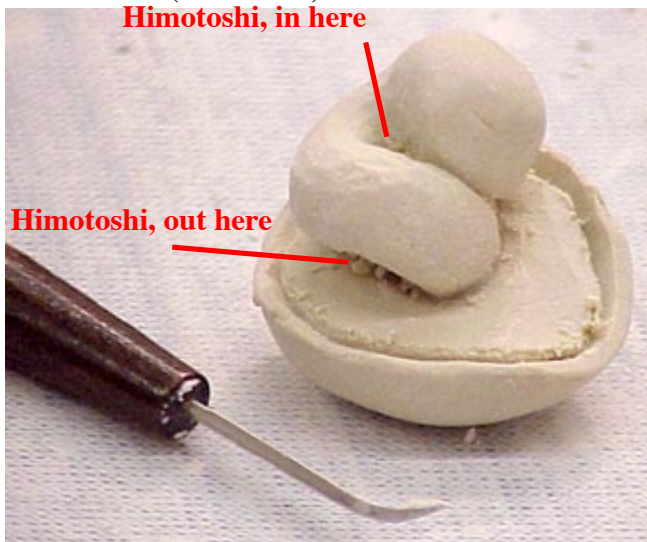

Gentle slopes carved around the stem and outer circle, and mushroom cap edges trimmed smooth.



The entire underside smoothed with paintbrush and clean water.

Now use the paintbrush and clean water to wet the entire stem and underside of the cap. If you take just



a few gentle strokes with the wet paintbrush on the wetted clay surface, all the little “nubbles” left from carving will disappear, and the rough surfaces will smooth out. **Be careful around sharp areas or tiny detail, because the water/paintbrush combination can rapidly “paint” them completely away!**

Next, it's time to clean up the top of the cap and the spider. The picture above shows two examples, the one on the left with a cleaned up spider, the one on the right shows the spider as it came from the press mold. You can also see a small area of wet slip (the whiter area) I used to fill in a small gap at the front of the spider on the right. Depending on how well the pressing went and the care taken during stem attachment and carving the underside, your spiders may be in different states of disrepair. Now is the time to fix whatever problems you run into. If the spider is beyond hope and you don't want to make one from scratch yourself, don't panic. Just repeat your press mold from the first steps, gently cut off the new spider, and attach it to the old mushroom cap using slip! Hey, it's clay! You can do all sorts of things. Nothing is permanent until it's fired.



**Left, a cleaned up spider**

**Right, typical spider as it comes from the press mold**

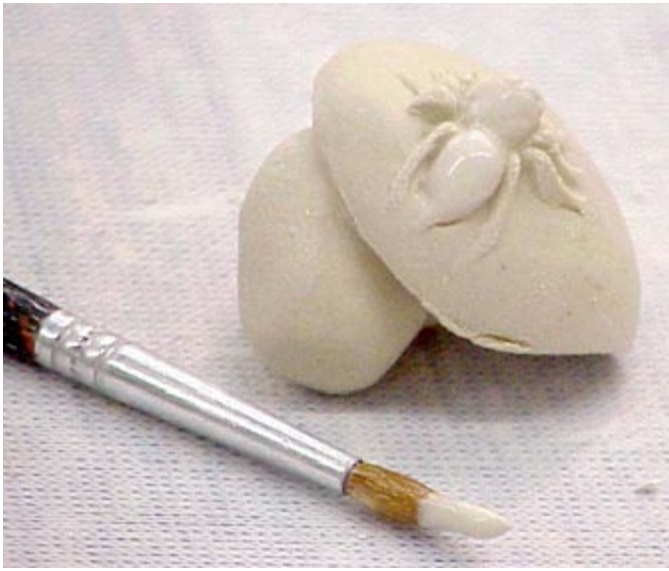

**My spider needed a little help with some slip to add depth to the body**

When all of the spider's parts are in place and accounted for, begin cleaning up by refining the two main parts of the body. Don't worry about the legs yet. The abdomen (hind part of the body) should smoothly taper to the back. The front part (the thorax) should have sort of a "suarish" look. Don't worry about cutting off the eyes, we'll put those back in with a paintbrush and droplets of slip. Did I mention this is a jumping spider? These don't build webs, but are active hunters and stalk around looking for prey. When they find something to eat, they jump very quickly and subdue it, rather than waiting for prey to come to them in a web.

Once the body is in pleasing shape, now it's time to doctor the legs and the two front feeding palps (near the mouth). Use the curved scraper to thin down the legs, tapering them from the body to the tips, and tapering the top edges. Tapering the top edges will allow the spider to look delicate, without making the tiny clay legs weak. If any legs are missing from your version, just use the paintbrush and slip to put them back on. That's how I made the legs on my spider prototype to start with, before I made the press molds. If you need to add one, start a leg by painting a small, narrow trail of slip on the surface of the mushroom cap. This is the most difficult part, getting the leg shape right, and not getting too much slip on the leg, making it wider than desired. Once this small raised leg is on the surface, it gets easier and easier to add slip without messing up anything. Remember, if you get too much on, just let it dry for several minutes and trim it up with the scraper, then continue on. You can probably expect at least eight applications of slip with the paintbrush to make a leg from scratch.

Now, it's time to add the gills to the underside of the mushroom cap. I chose this order because I can probably (if I'm careful) avoid squashing the spider on the top while I carve the gills on the underside, but probably would have squashed at least some of the gills while I worked on the spider, had I carved the gills first. Using the edge of the scraper like a knife, I simply made light cuts very close together, starting

at the stem and working radially outward to the edge of the gills. Don't continue on to the edge of the cap. Leave a small gap there. It just looks nicer that way. By the way, working from inside to outside isn't magic. If you want to work the other way, fine. You may find areas near the stem where you'll want to work the opposite way. Whatever works.

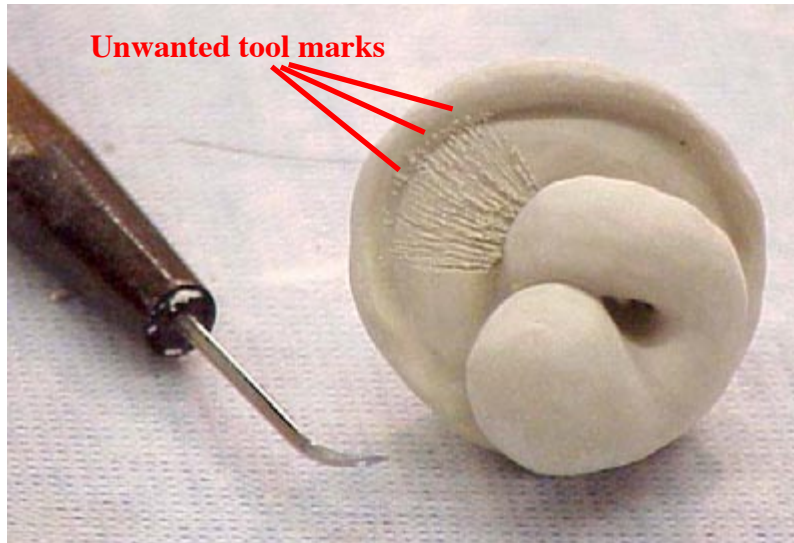

**The start of the gills. Notice where the scraper sometimes leaves small marks on the edge of the cap where I don't want them. I'll clean those up with paintbrush and water later.**

Since you've finished the top and the bottom sides now, it's time to add your signature. I chose the base of the stem for mine. My signature is my initials all together in a stylized format that has a sort of Japanese look to it. The signature may be the most difficult part. You need to incise the lines carefully, and then go back over them several times.

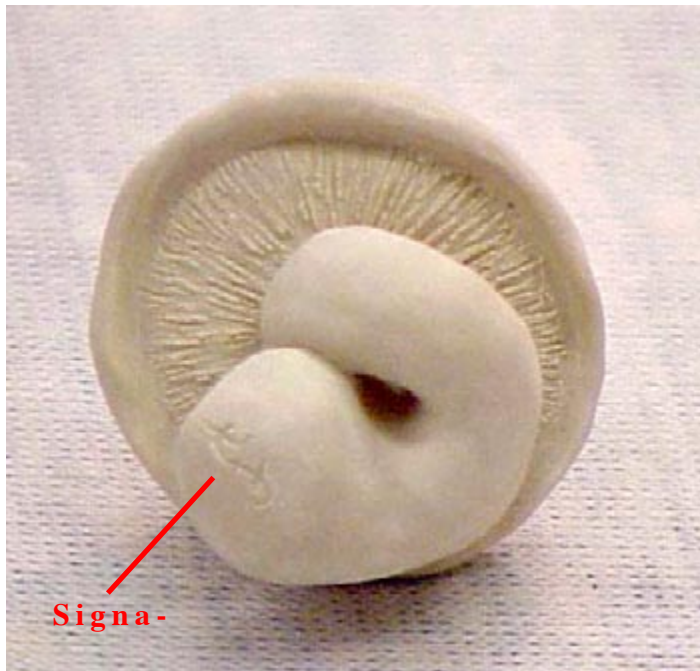

**The finished gills. Note my signature on the base of the stem.**



**The finished top side.**

Here's the finished top side. Note I've added two large eyes on the front of the head, and two smaller ones to each side. I used a paintbrush and small drops of slip for this.

Now is the time to consider whether you'll be satisfied with the netsuke as is. Below are examples where I've taken the standard model and added a few bells and whistles. On the left, I've added three ants for the spider to eat, one in plain slip, and two using slip from a black clay, by repeated applications with the paintbrush. You can find lots of different colors of clay at pottery suppliers, or make your own from the regular slip by adding dry powdered stains you can also purchase at the pottery supplier (ask for Mason stains). On the right, I've carved a face, and used the black slip for the pupils of the eyes. Let your imagination run wild, and enjoy!

**Making ants** - or for that matter, any kind of small insect. How about a ladybug? Any takers? Begin with a paintbrush and yogurt-consistency slip. I'm using black slip here. Think of ants as basically three parts, with six legs. There's the abdomen (oblong, with a point at the back end - the stinger), a round dot for the thorax (center part) and another, larger round part for a head. First, put in the abdomen, then the thorax, then the head. Now is the time to get the shapes right. Trim anything that needs trimming with the scraper now. Then add successive layers of slip (about eight) to build up the body to the right height. Carefully add the six legs. If you're using dark slip, you don't need any thickness here. One stroke will do. If you're using a slip the same color as the surface, you will need several layers so the legs are visible. Voila, you've got ants!

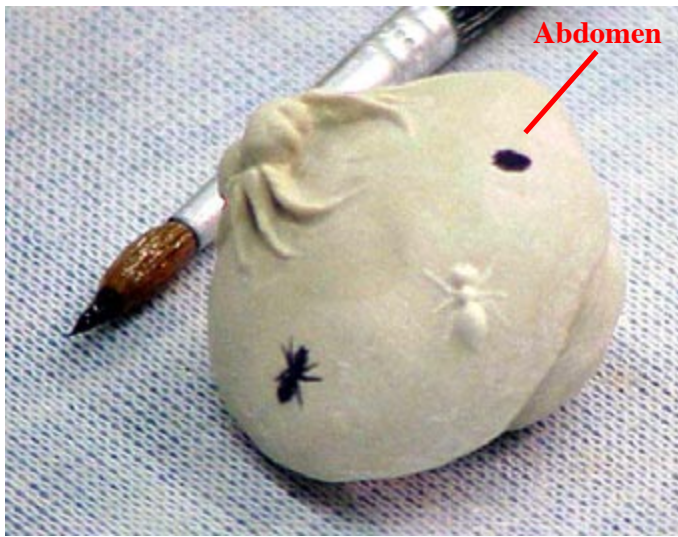

Step One - the abdomen

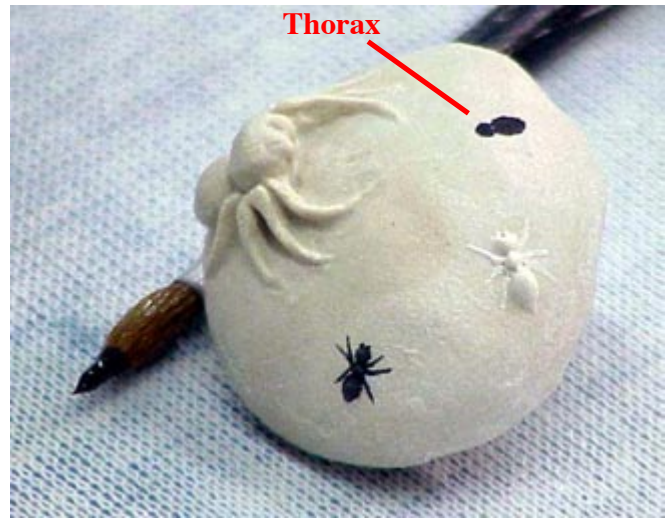

Step Two - the thorax

**Firing** - The piece is now ready to let dry completely, and then fire. I'd let several days elapse for complete drying. If the clay is wet at all during the firing process, it will explode and ruin the piece, and maybe several next to it as well. The clay I use is Dove porcelain, and is a cone 6 limit clay. I recommend you fire it to the cone 6 limit, using a slow "candling" at the beginning. Candling is allowing the clay to sit in a warm kiln for several hours to make sure all of the water is removed. For an electric kiln, I use 3 hours on a low temperature setting, followed by 3 more hours slightly higher, then 3 hours at half maximum temperature, then the remainder of time on high, then letting the kiln sit unopened overnight to cool down.

## Floating Treasures:

This style of carvings I call "Floating Treasures" since the subjects are on small raised platforms that seem to be floating inside the bowls of colored hardwoods. They are loosely based on Japanese "Kagamibuta" style netsuke, altered to be more useful for pendants.



The platforms in each of the above cases are of carved and pyrographed English boxwood. The bowl of the heron pendant is purpleheart, the bowl of the cherry blossoms pendant is bloodwood, the illuminated manuscript heron bowl is mesquite. The moon and cherry blossoms are of recycled hippo tooth ivory.



Here are the components for a "Floating Treasures" pendant: a small bowl (in this case moose antler), a small platform (note undercut) with a 1/4 inch diameter tenon either turned in place or installed separately. A small shim disk may be necessary to raise the platform up to the correct height if your measurement guess was a little off. The platform is turned to be a close fit with the mouth of the bowl, and the tenon insures proper centering as well as indulging my penchant for mechanical holding as well as glue. The platform (and shim, if necessary) are epoxied into the bowl during final assembly - carving is done prior to installation in the bowl. The tenon is slightly longer than necessary and is trimmed flush once the epoxy has cured. Don't forget to carve the holes for the necklace cord prior to installing the platform!



While developing this concept, I noticed my work-holding hand (my left) was hurting from the effort of holding such small items. Remembering back to my metal machining days, I recalled a trapping mechanism sometimes used for holding work on lathes and mills. My version is shown above with a "Floating Treasures" platform blank installed, ready for carving. I adapted it work for the tiny platforms here (a little

larger than an inch in diameter, but not very thick). The resultant fixture worked so well for this purpose that I'll be using it for many other kinds of small work. All that is required is a small tenon or peg either included in the work or attached.



Here is the holding fixture without a work piece. It consists of four parts; a wood screw (tip ground flat), two short sections of dowel and a wooden disk. A short section of dowel, drilled longitudinally slightly smaller than the wood screw thread diameter, is glued into a hole that cuts through the disk from side to side. This dowel is shorter than half the diameter of the disk. A freely-sliding dowel section is installed next, with a 1/4 inch hole drilled vertically through both the disk and the dowel. The wood screw is flat-tipped so as not to dig into the sliding dowel. To use, the 1/4 inch diameter tenon on the bottom of the "Floating Treasures" platform slides into the center hole in the disk and the sliding dowel. Tightening the wood screw pushed against the sliding dowel, trapping the tenon between the disk and the sliding dowel.



**Step 1: Wood screws, 2 x 1/2 inch diameter dowels, 3/4 inch thick disk**

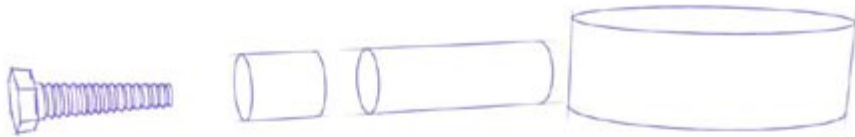

**Step 2: Using drill bit the same diameter as dowels, drill hole through disk edgewise**

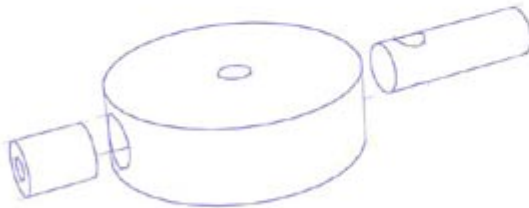

**Step 3: Insert long dowel into position. Using 1/4 inch drill bit, drill perpendicularly through disk and long dowel. Using bit smaller than screw diameter, drill through long axis of short dowel.**

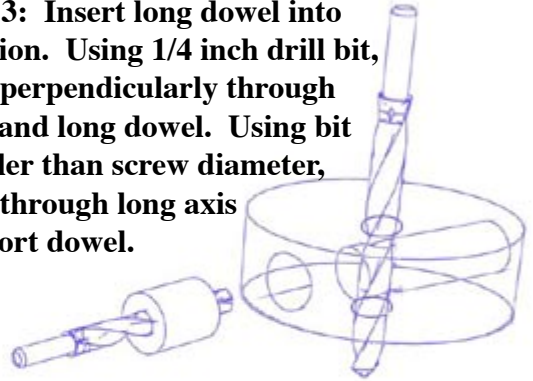

**Step 4: Glue short dowel into position. Long dowel must fit well but move freely. Grind tip of screw flat, install when glue is dry. Carve disk to comfortable shape.**

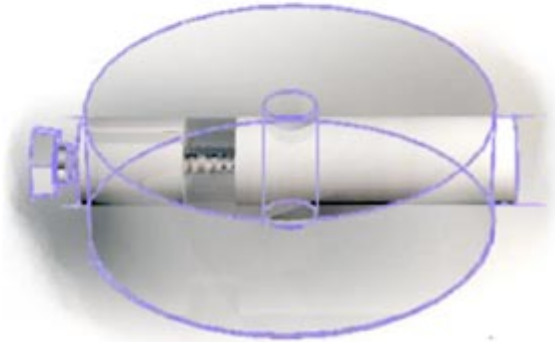

Here's a blueprint with instructions on how to make such a holding fixture. There's only one real trick to pay attention to during assembly: the sliding dowel and disk are drilled simultaneously, and unless your measurements are spot on center, you must assemble the sliding dowel and disk in the same orientation they were drilled, or the held object won't fit flush and flat against the disk surface.

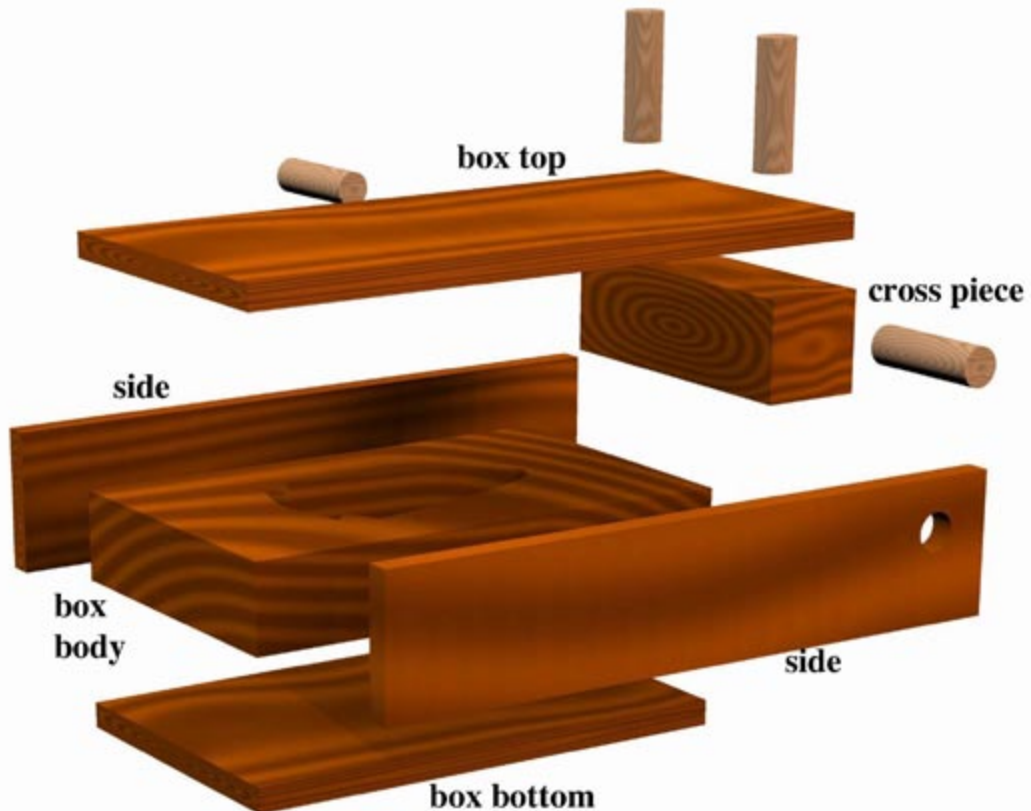
*Elegant Display and Presentation Box*

Here's an exploded diagram of the box we'll be making. I've not included any specific dimensions. I've made boxes as small as an inch and as large as 10 inches using this style of box. Have fun! The only

drawback I've sometimes found is there seems to be more interest in the box than the work in it. I wonder what they're trying to tell me?

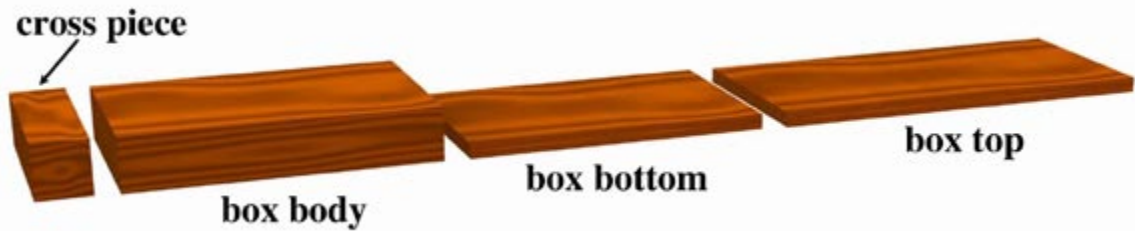

Begin by cutting two lengths of wood that are the same width. The easiest way is to set up a table saw and rip a piece of wood for the body that is thicker than the object to be stored in the box. Without changing the saw setup, rip a length of thinner wood that will be the top and bottom. The bottom will be the same length as the body of the box, while the lid must be about 25 percent longer. Cut the crosspiece from the piece used for the box body. It should be the same width, and square in cross section.



On the box body, trace around the object to go in the box, leaving a little extra so the object can be easily removed. If you're going to line the edges of the interior, leave extra space for that.

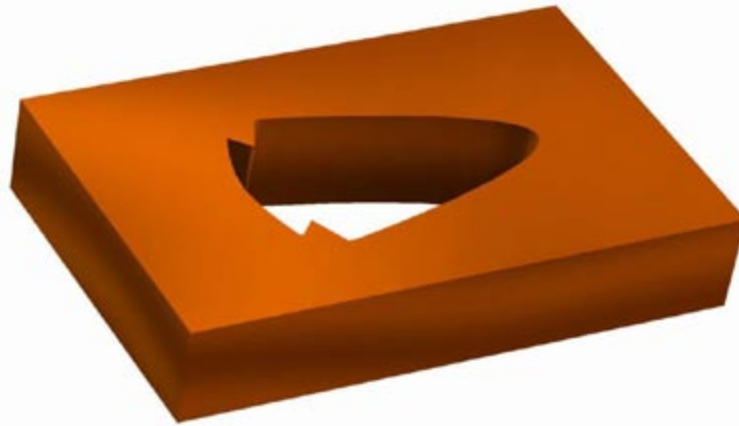

Cut out the shape, leaving a void. Test fit the object to make sure the object fits without jamming, making corrections as needed. Now is the time to sand the inside of the void to the extent desired. This will be more difficult later in the process, so do it now. If you want to line the edges of the void with leather, felt, velvet, etc, now is the time to do it while you can trim both top and bottom surfaces. Also, sand the top surface to final finish quality now, before the sides go on.

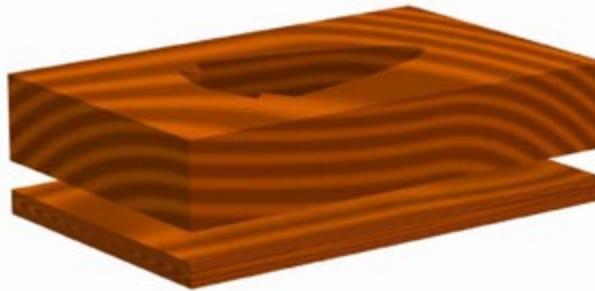

Carefully glue the bottom to the box body, making certain you're gluing the bottom to the correct side. Listen to me, been there, done that...While I seldom use cyanoacrylate glues (superglue) for anything critical, I make an exception here since it makes the box making process so incredibly easy. I use the thicker, slower-setting gap-filling glues for this. Once you have the bottom where you want it, squirt a little accelerator on the sides. DO NOT squirt it in the inside. Often the accelerator causes the instant glues to take on a white color. The outsides are going to be sanded, so it won't matter there, but the inside is much harder to deal with.

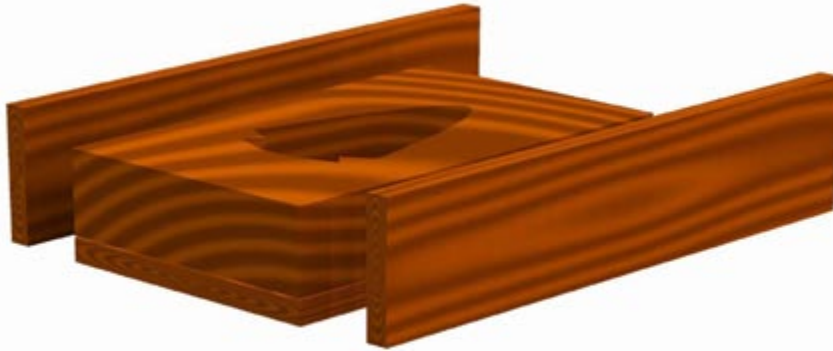

Now cut the sides. They should be of the same thinner material used for the bottom and top, and must be at least as tall as the combined bottom, box body and top. Their length should be as long as the top.



Here's a front view. If you have a belt or disk sander, it's alright if the sides are a bit taller than needed since you can sand all sides at the very last to bring everything into perfect fit. Glue the sides on, using accelerator on the outsides where you will sand, but not along the joint with the top of the box body - the white problem again.

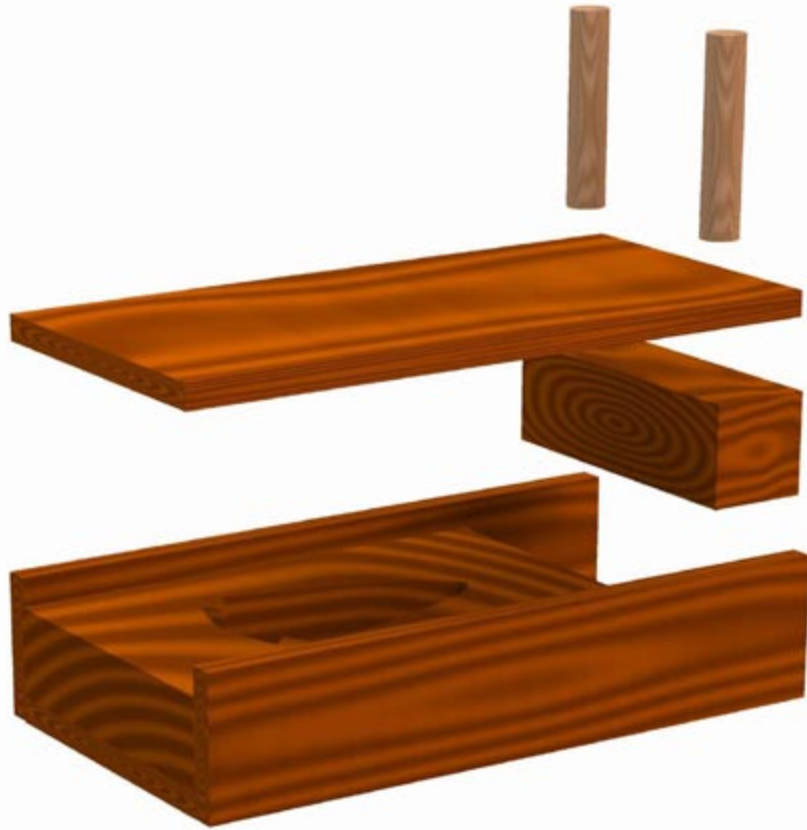

Now assemble and glue the top and crosspiece. The crosspiece needs to be square to the sides of the top, and flush with one end. I like to drill through the top and the crosspiece and insert and glue dowels for extra strength. The dowels look nice if they are of a contrasting wood.



Cut and sand the dowels flush on the bottom of the crosspiece, but at this point it's alright to leave the top standing proud. These will be sanded flush after final assembly.



Fit the top and crosspiece into position. There should be some distance between the inner edge of the crosspiece and the end of the box body to allow for rotation of the crosspiece when opening the lid. Carefully drill trough both sides and the long center of the crosspiece with a drill bit the same diameter as the dowels that will be the hinge pins. I find 1/4 or 3/16 inch dowels sufficient for most hinges. Smaller may be a little too delicate, unless the box is quite tiny.



Using a good-quality wood glue (not cyanoacrylate glue here) and a cotton swab, smear glue inside the holes in the crosspiece ONLY. Any glue getting on the sides will prevent the box from opening. Insert a dowel from each side. I find it is much easier to use two dowels, rather than trying to force a single long dowel through everything, gluing the wrong parts and possibly splitting the crosspiece.

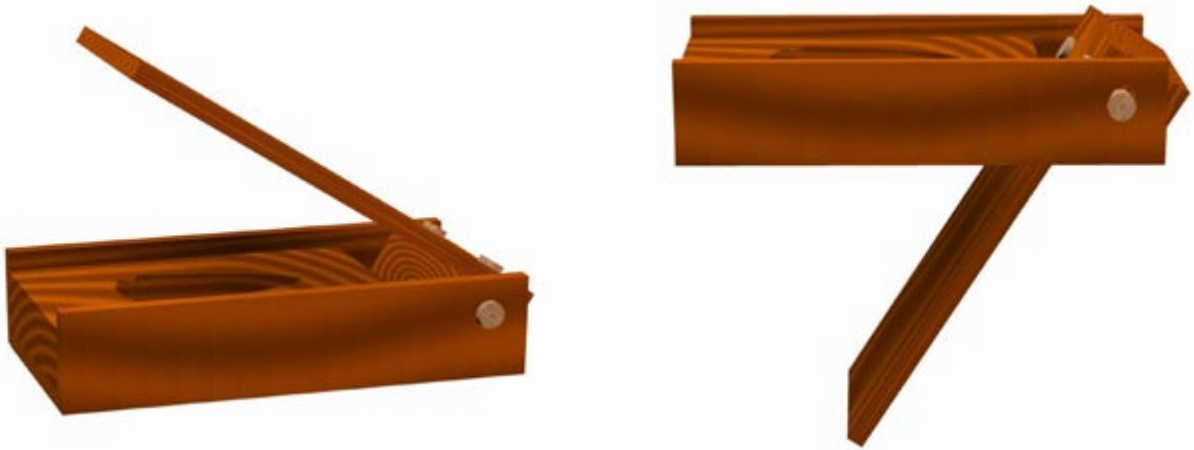

The box is now ready for testing. The lid should swing easily about 300 degrees, finally coming to rest against the forward edge of the box bottom. With the lid down, the box will sit up as a display stand. Make certain it's not too tippy and that the precious object inside can't easily fall out.





The whole thing is ready for final trimming and flush sanding everything. I use a bandsaw for trimming and a belt and disk sander combination for flush sanding, then an orbital sander for final smoothing. As a nice little added touch, I carve or sand a small thumbnail depression in the end of the lid for easy opening. Use a good quality oil finish and your box is ready for show.

## **Making a Buckskin Pouch**

OK, a buckskin pouch isn't exactly a netsuke or an intro. However, you can use a pouch as a nice little addition to put a netsuke in, and some of my clients have enjoyed the small medicine pouches I make with a little carved "fooferaw" or doodad as a little netsuke-like attachment. For what it's worth!

## **"Rock Candy" Pouch**



Carved  
Detail

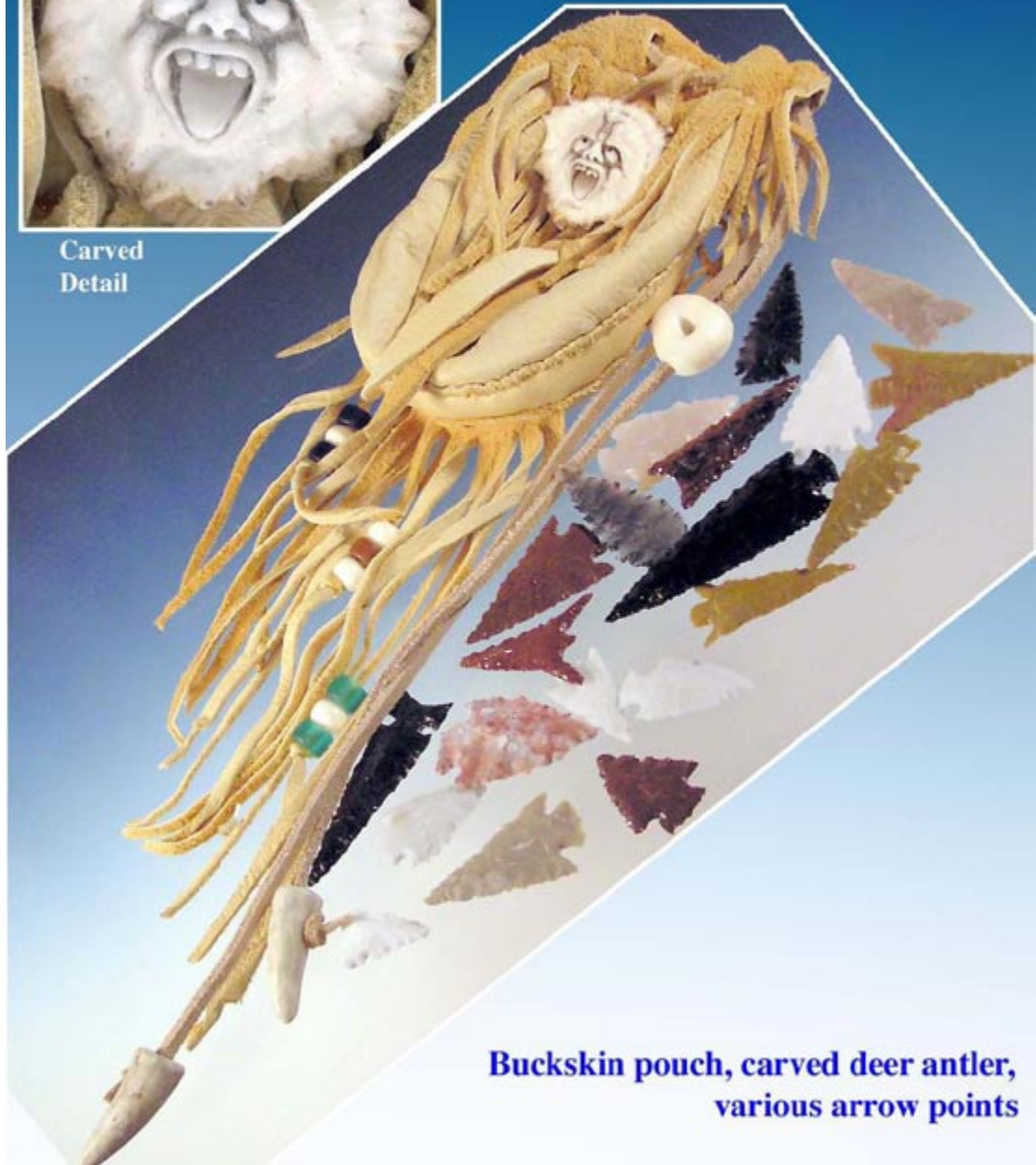

**Buckskin pouch, carved deer antler,  
various arrow points**

Here are instructions for making a high-quality buckskin pouch, as presented to me by a good friend who is a member of the Ute Indian nation. He received his instruction from his grandmother, an unbroken line of oral tradition from the distant past. A small piece of history, and a great honor for those of us without a direct connection to our roots.

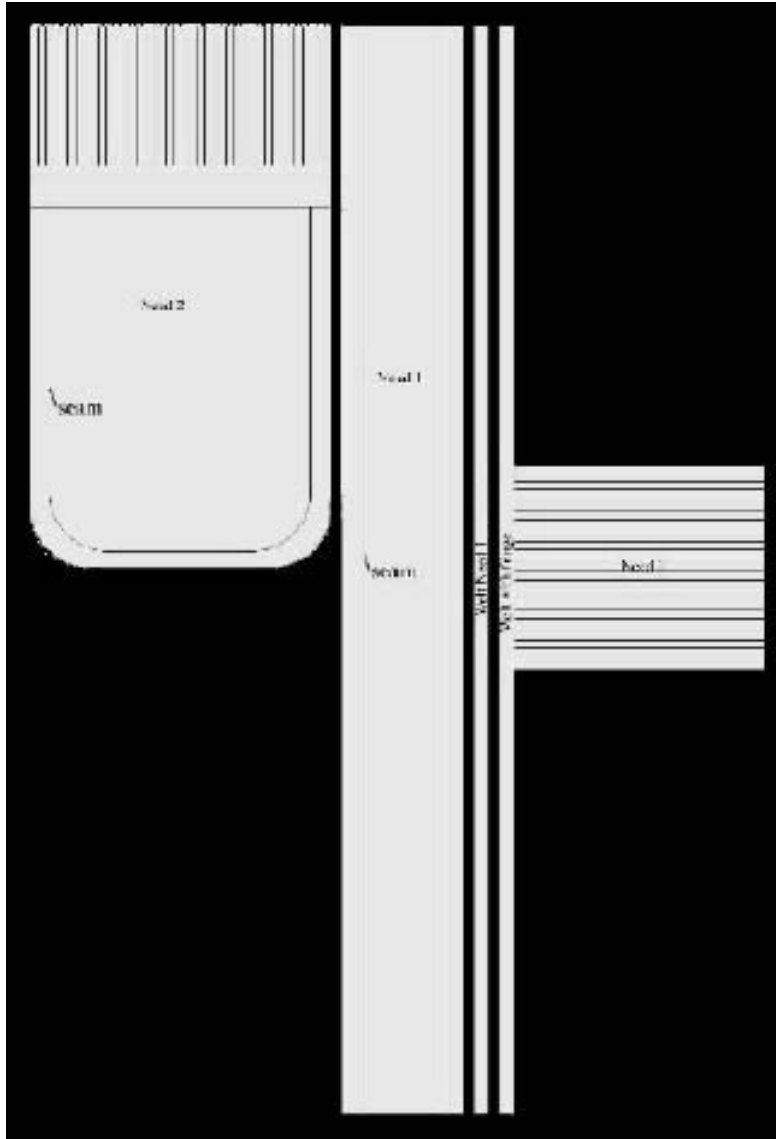

Here is what the pattern looks like. You'll find full-size, printable patterns in a separate PDF, in three different sizes, for three sizes of pouch. The file is called [Buckskin\\_Pouch\\_Patterns.pdf](#). The largest and middle size patterns will be printed out in three parts, which need to be cut out and taped together.

The pouch consists of five separate pieces, the front, back, side portion and two welts that fit in between the front and side pieces. One of the welts has a larger section that will become fringe once the pouch is completely assembled. The welts improve the looks of the pouch markedly, and have a practical side as well. They provide a thicker seam, allowing the thread to be pulled below the surface, and protecting the threads from being cut by the contents of the pouch.



I printed the instructions, glued the separate sections together (some of their dimensions are larger than a single sheet of paper), pasted them onto cardboard and then cut them out. Here's an image of the patterns traced onto the buckskin. I used a ballpoint pen to trace the patterns onto the leather, because ballpoint ink won't run like felt-tip pens will.



Here's an enlargement of the welt with the fringe section. Notice the long thin portion isn't laid out in a straight line. Long, thin sections don't need to be laid out in a straight line. Since they're going to be curved around anyway, you can wrap them around and save a little leather.



Here are the five pieces cut out. Notice I didn't cut out both of the welt patterns, since other than the rectangular portion for the fringe, they are identical in size and thickness.



Also, notice I left the bottom of the fringe section long, and it's not square along the bottom. I simply accepted what the leather was like in that position, since I've found that uneven fringe looks the best. At least to me. Also, the front and back portions have the same kind of uneven tops, since those areas will be folded down to make fringe with as well. I recommend you look for uneven sections of the skin for your fringe areas.



Now we'll begin assembling the pieces. Here I've laid the back section down, good side up (the smooth side, not the rough flesh side). On top of that, I've laid the fringe welt section, also good side up.

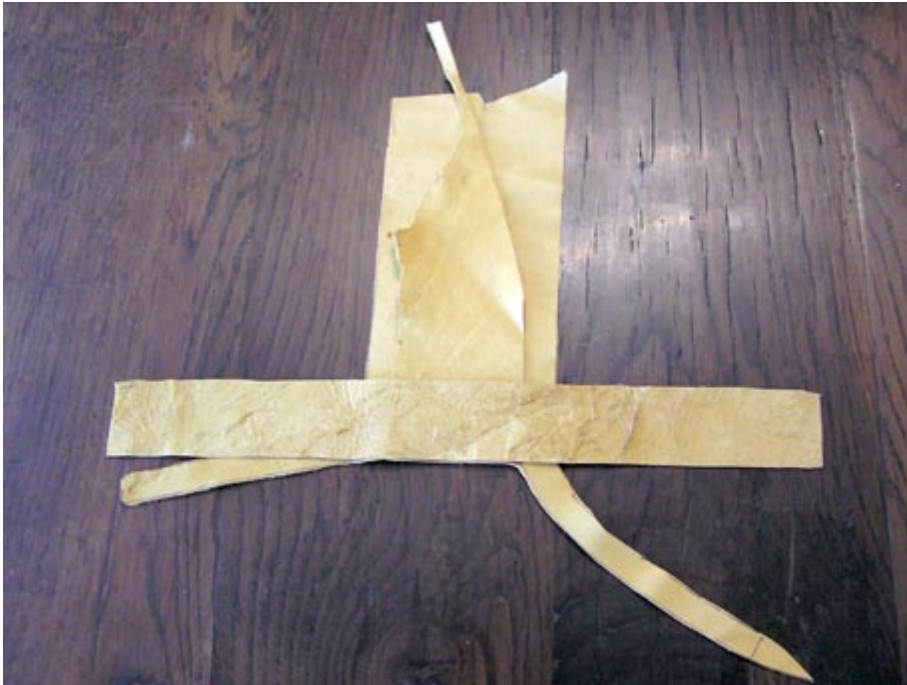

Now I've laid the side piece on top, flesh side up, and centered on the back section. You can easily find the center of the side piece by folding it double - the fold is the center. We're assembling the sections in this order because we're going to be sewing the pouch together inside out. Once we're done sewing, we'll turn the pouch inside out, and this arrangement will result in the good sides of all the sections ending up on the outside, and the good side of the fringe facing to the front side of the pouch.

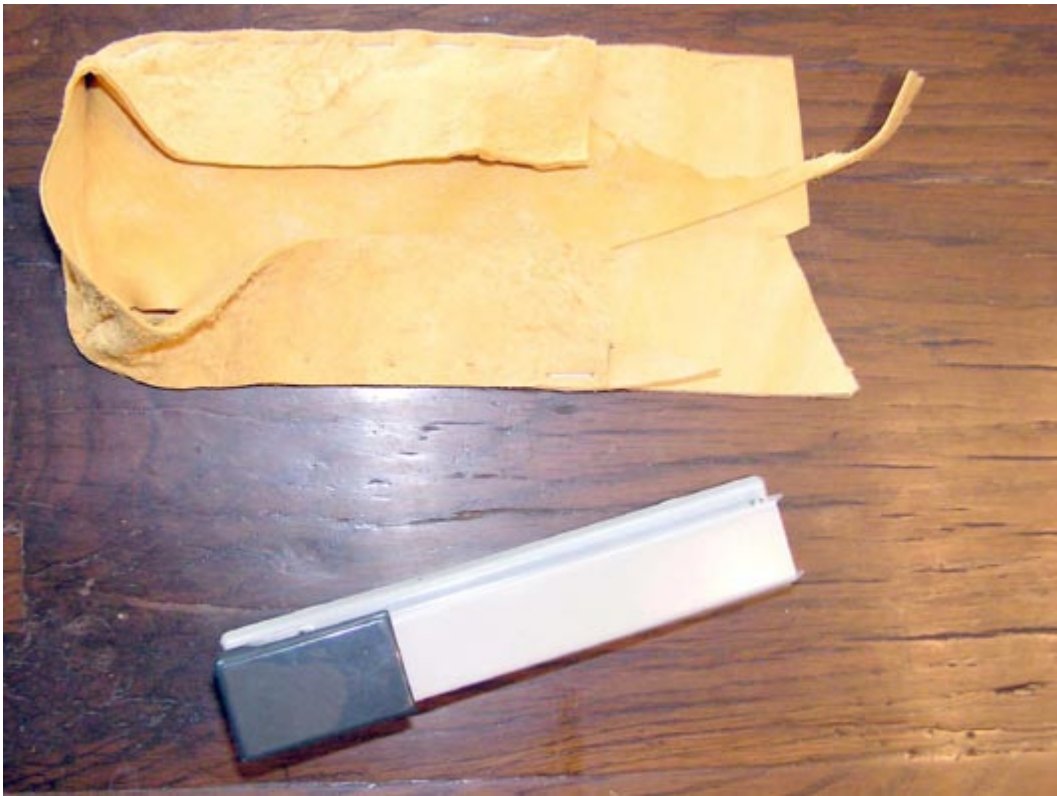

To hold it all together we could pin it, but I'm constantly running the pin into my fingers since the leather is fairly tough. A far easier solution is simply to staple it together. Much easier on the fingers, and we're going to trim the stapled portions off later. Be sure to staple reasonably near the edge, as we're going to make the sewing seams inside of the staples.

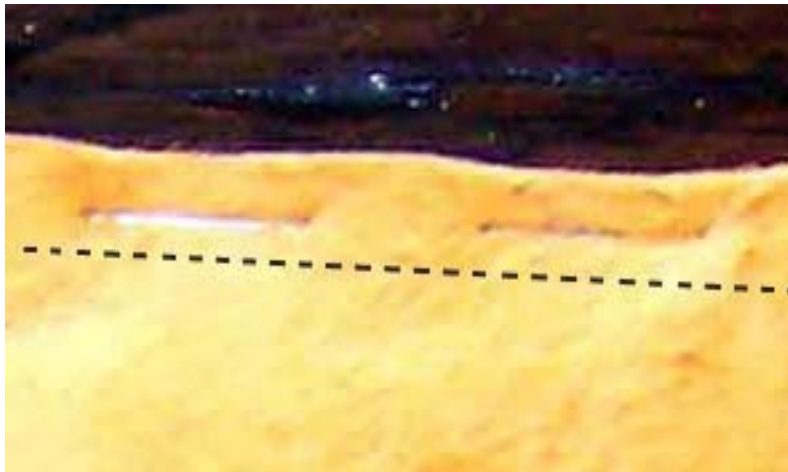

Here's a close-up of the staples. I've used the magic of the computer to draw in the seam. If you're unsure of yourself and want to draw in a seam line, use pencil lightly, not pen. Ink is permanent and will look terrible in the finished pouch. All of the ink marks we made laying out the pattern will be trimmed off at the end.



We're ready to poke holes in the leather for sewing. The ancient ones would have used an awl to make the holes, but we're going to use modern medicine. Above, I've taken a two-inch finishing nail like the one at the top of the picture and clipped off the head and sharpened the point. We're going to chuck the nail into a drill press and actually drill holes in the leather. If you don't have access to a drill press, leave the head of the nail on and use a hammer and piece of wood, or do it in the traditional way and use an awl. Watch out so you don't push it through the leather and stab yourself!



Here's the nail chucked in the drill press. We're using a sacrificial piece of wood to lay the stapled leather on, and drilling through the leather and into the wood. By the way, don't use a drill bit for this. Drill bits will remove leather as they make holes. You're left with a large hole that won't close up and hold tightly to the thread. The sharpened nail simply spreads the leather apart, and will close up later, holding tight to the thread.



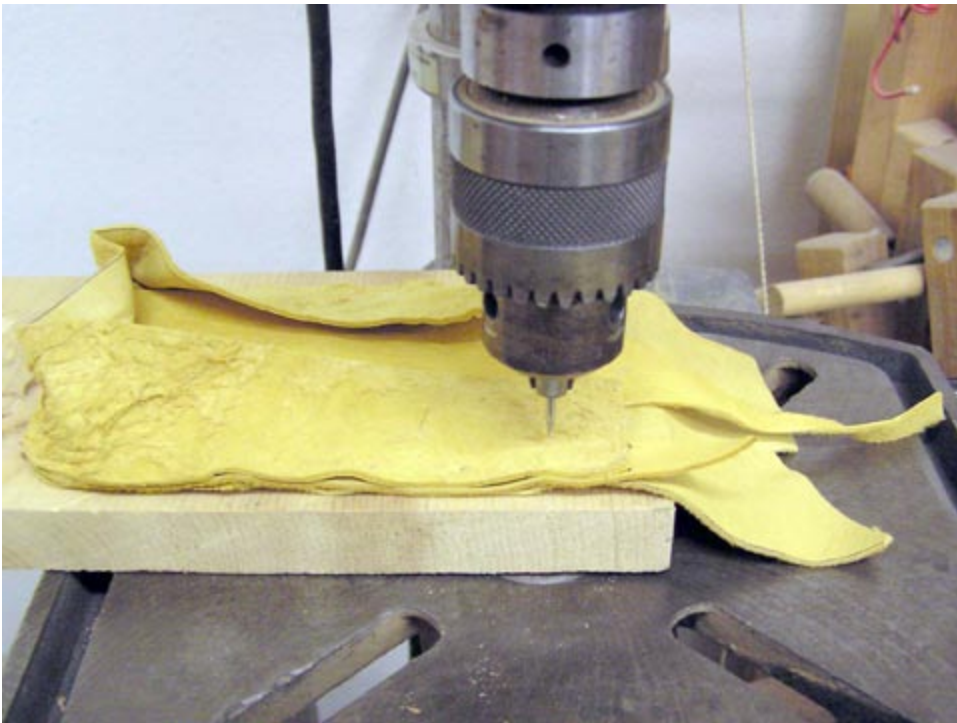

Here's the drilling operation. Once I've drilled a hole, I move the leather and the wood at the same time to the next position. This seems easier than moving just the leather.

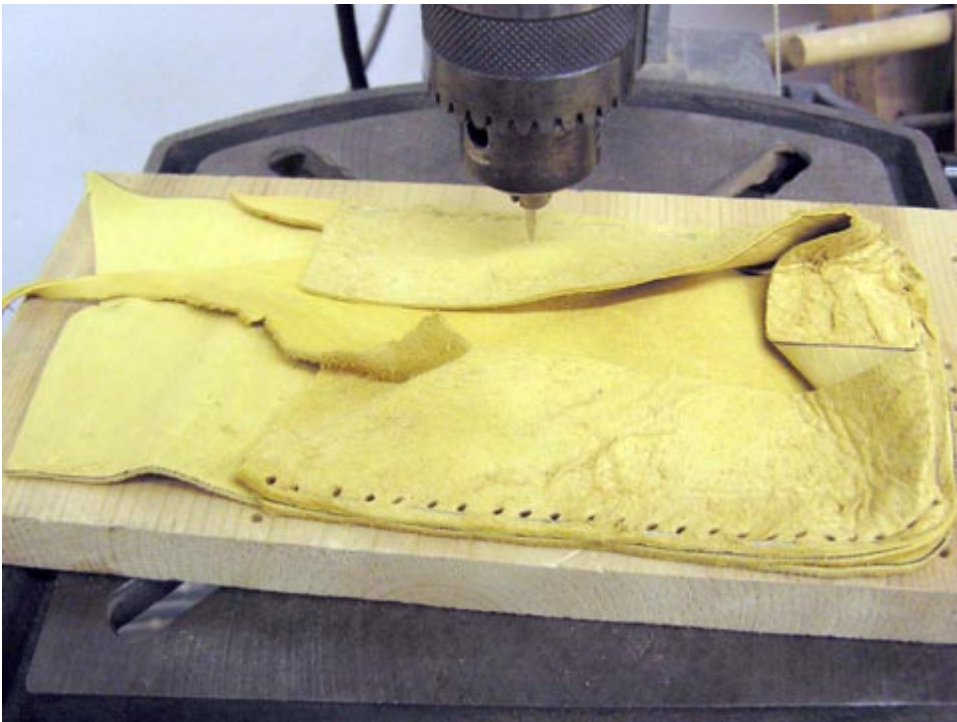

Here's the finished row of holes. I'm drilling them about 1/8 of an inch apart.

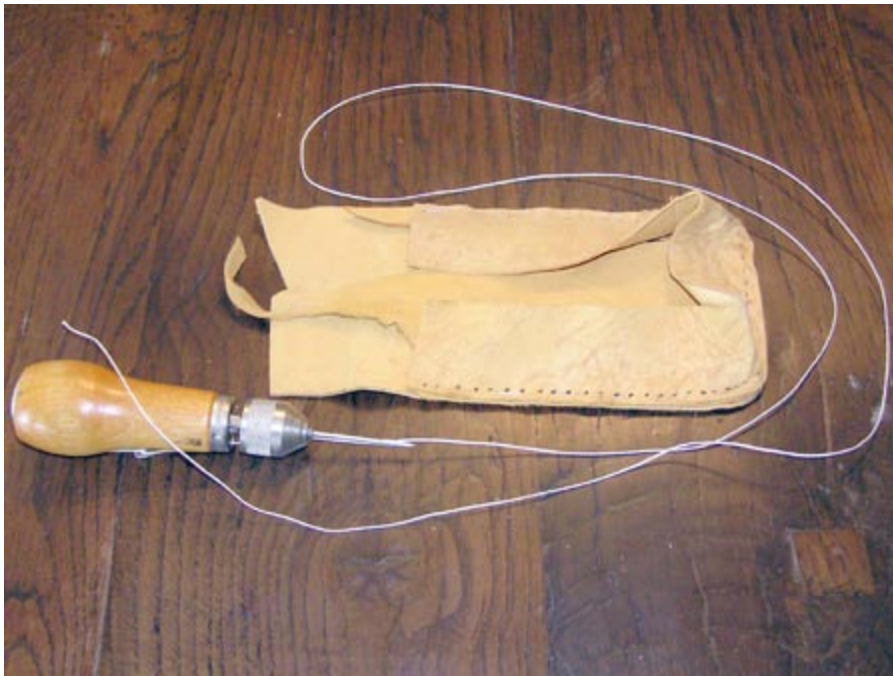

Now we're ready to begin sewing. Here's an image of the drilled leather back, side and fringe welt sections assembly along with the sewing awl. You'll need to pull out enough thread to go around the drilled seam about two and a half times. By the way, this is a specialized waxed linen leatherworking thread.



I've begun sewing the seam by inserting the needle through the first hole in the end, grasping the loop of thread and pulling it all the way through the hole, then pulling out the needle. It doesn't matter which end hole, just choose the one you feel the most comfortable with.



Now insert the needle into the next hole, and pull it back out a little. This should form a small loop next to the needle, on the side away from the awl.



Take the loose end of the thread and thread it through the loop. Pull the thread all the way until it is

taut, and pull the needle all the way back out. You should have the free length of thread on one side, and the thread attached to the awl on the other side. Pulling the thread from both sides, pull the resulting "knot" down into the three layers of leather, hiding the knot and pulling everything tight. Don't break the thread.

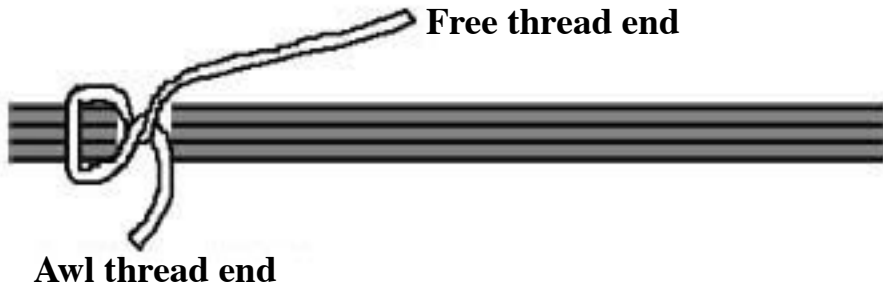

Work your way around the entire seam. To finish the seam, insert the needle through the last hole, thread the free end through the loop, then pull the needle completely back through the hole. This time, pulling on the awl end thread, pull the free end thread all the way back through the hole. You should wind up with both threads on one side of the leather, rather than a thread end on each side.



Now cut the thread near the awl and tie a square knot. Carefully put a drop of superglue on the knot to prevent it from unravelling, being careful not to get the glue on the leather, since it will discolor the leather badly.



Now we're ready to staple the front section onto the already sewn back and side portions. Be sure to place the long, thin non-fringe welt section between the side and front parts. Note the front section is placed good side in. It doesn't matter which direction you place the welt section.



Here's the whole thing stapled and drilled, viewed from the front side. I found it easier to drill with the back side up, manipulating the leather back and side out of the way as I worked my way around the seam.



Here's everything sewn and tied off. Now we're ready to turn the whole thing inside out.



Here's the pouch turned inside out, viewed from the front side of the pouch. Now it should be clear why we assembled everything paying attention to which sides faced in and out.

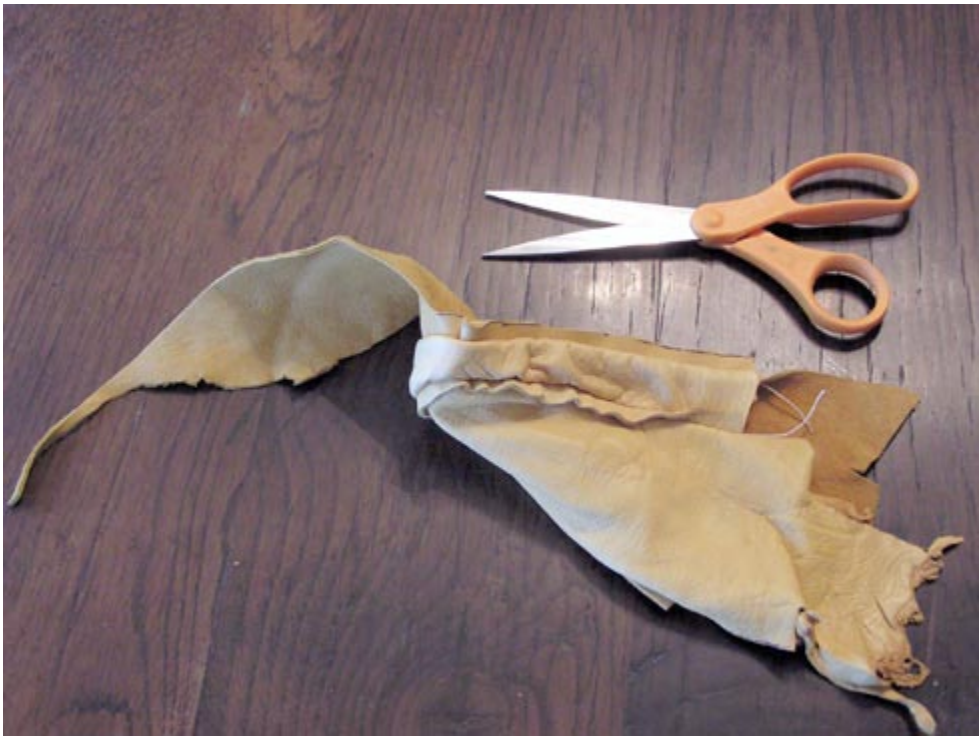

Now we're ready to trim the welt portions close to the seams. Just use a large pair of sharp scissors for this task.



Here, we're trimming the welt. The idea is to trim the welt closely, but not so close as to cut the threads.





Here's the trimmed welt. Be sure to trim the welts on both sides.



Here's a close-up of what your finished, trimmed welt should look like.



I've also trimmed any excess from the side portions, trimming about 1/8 of an inch above the threads. Then, fold over the top, making a cuff about half an inch wide. Here you can see how the excess leather from the front portion folds over, leaving leather for fringe.



We're now ready to punch holes for the drawstring. This is one area where messing things up is quite easy, because the number of the holes matters! If you get the numbers wrong, then the drawstring won't work or won't emerge correctly. Here we're going to punch two holes in each side, and two evenly spaced holes in the front and back sections, for a total of eight holes. On the prototype you can see I ran a seam around the top. This is optional, since the drawstring will hold everything in place. It's preferable to use a leather punch, but if you don't have access to one, you can cut small slits. Slits are inherently weaker, however, and may rip with continued use. Select a leather thong for the drawstring, and choose a leather punch size that will allow the thong to slide easily. Use a scrap of leather to determine which size hole works best.

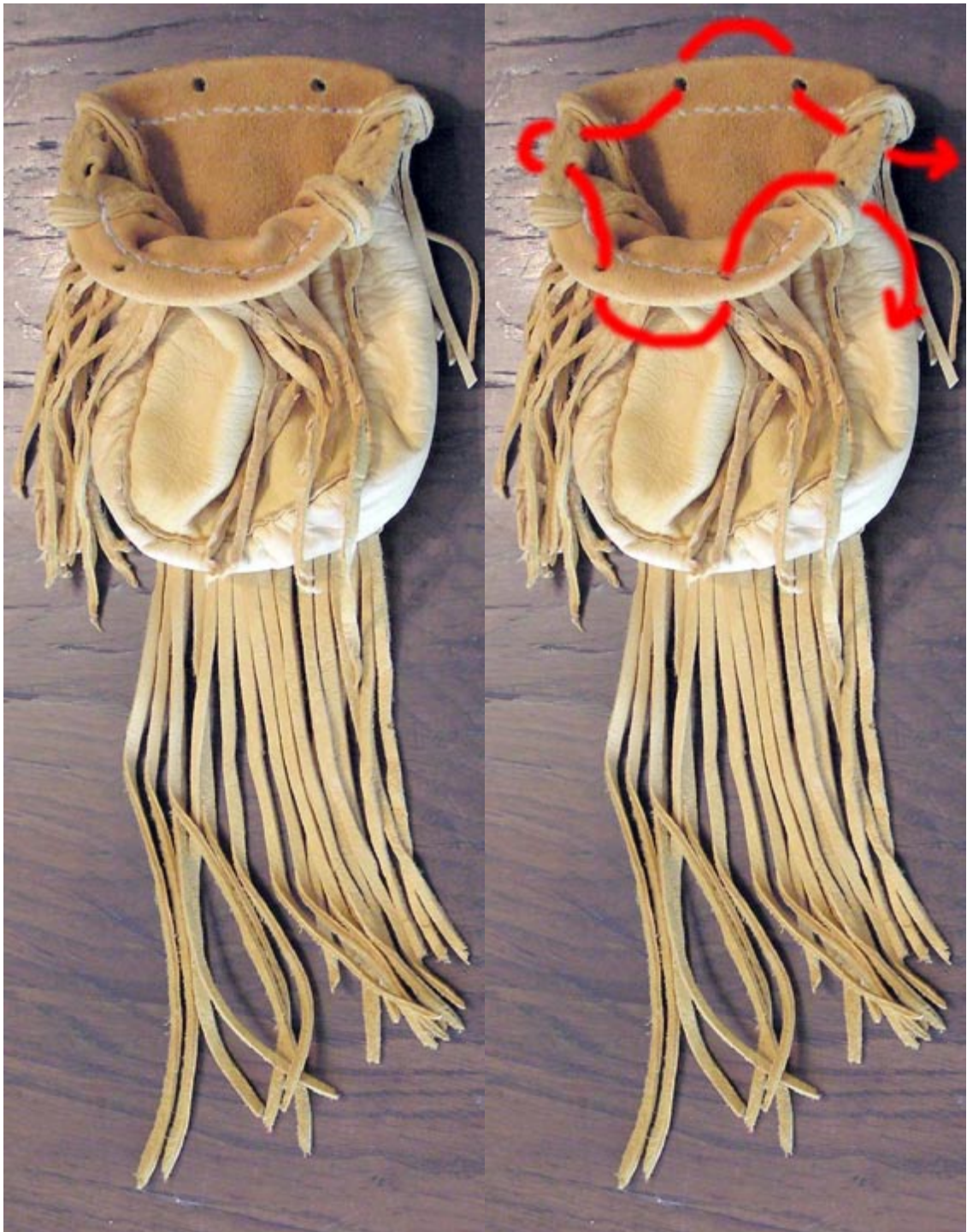

Here are the punched holes, along the sequence for threading the drawstring thong. I've also used a sharp pair of scissors to cut the fringe on both front and back sections around the top, and the long fringes at the bottom. Here is another make or break point, since smaller fringes look better. You can tell if a lazy person cut the fringe if they are wide. For an alternative look, you can wet and twist the fringes tightly.



Here's the finished pouch, both open and drawn closed. I like to put small carved embellishments to dress up my pouches. You can also put trade beads on some of the fringes, and the ends of the drawstring thongs for added decoration. Enjoy!



Group of pouches, full sized, small and tiny.



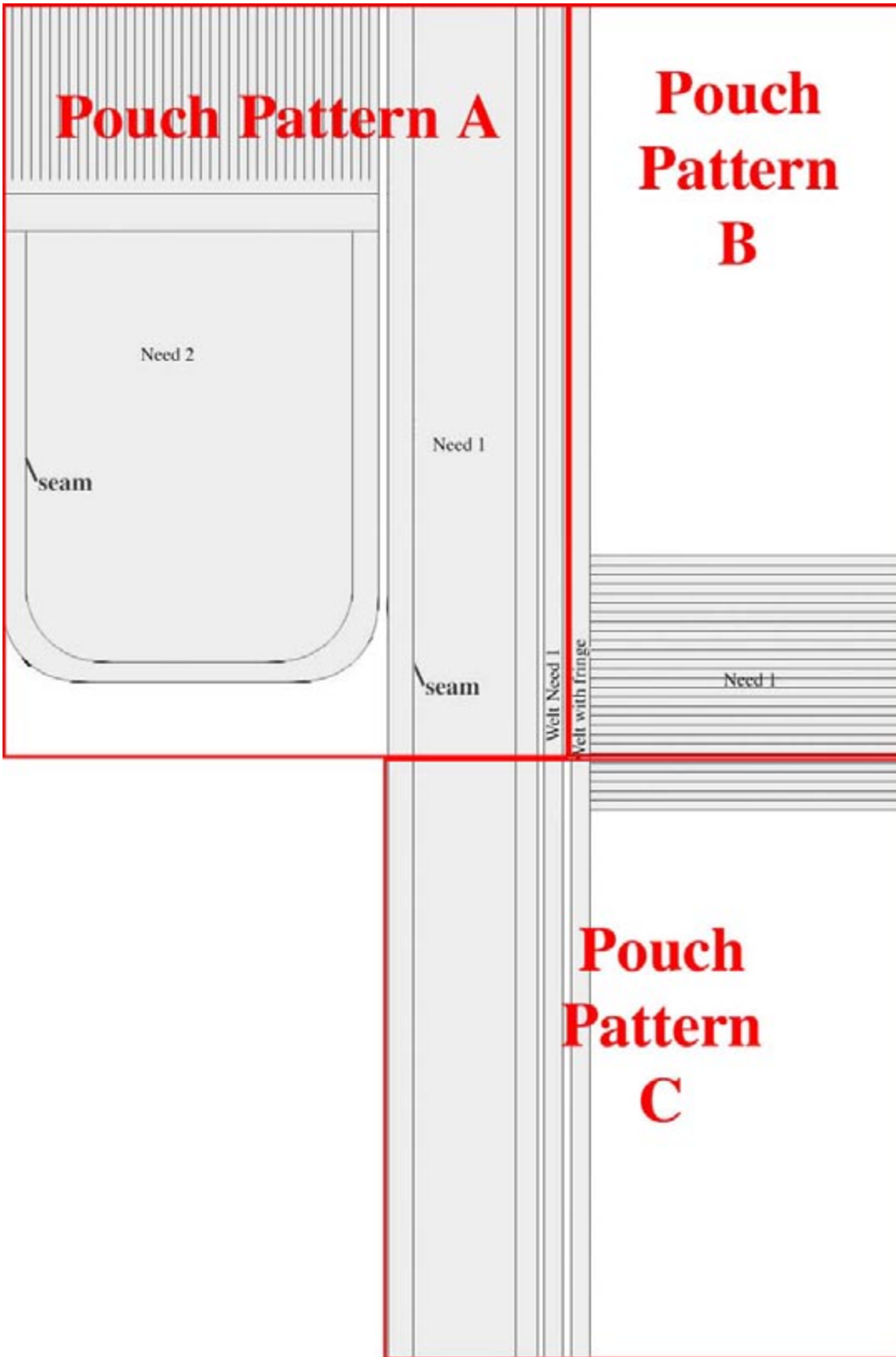

Gluing sequence for the full sized pouch. Print the A, B and C portions, glue together, glue to cardboard, then cut each of the patterns out.

## Medicine Pouches

These are some small medicine pouches I've been making, each with a small carved talisman. They've been a lot of fun, and popular with my clients and friends.



This medicine pouch has a small antler orca (killer whale) talisman in Northwest Native American style. On the back of this talisman is a slot-like himotoshi to allow the "bleed knot" fastening device. The medicine pouch is about 2 1/2 inches tall, and is designed to be worn around the neck. Note the neck cord that is arranged to be both pouch closure and necklace, with an antler toggle fastener. The antler toggle is simply

a rod of antler, tapered and smoothed on both ends, with a groove around the center so the buckskin thong could be tightened and not slip off. I cut the fringe as the last thing in making the pouch, then soak it in a dilute water based stain (in this case a natural walnut hull stain) to darken the pouch a little, and get rid of the yellowish "new" look of the leather. You have to squeeze the leather a bit to get the stain to penetrate well. While the pouch is wet, I twist each fringe, then twist each one a little tighter a few days later when the pouch is completely dry. After that, the twist is pretty permanent. A word of note, the talisman isn't attached during the staining and drying, or it would be stained as well.

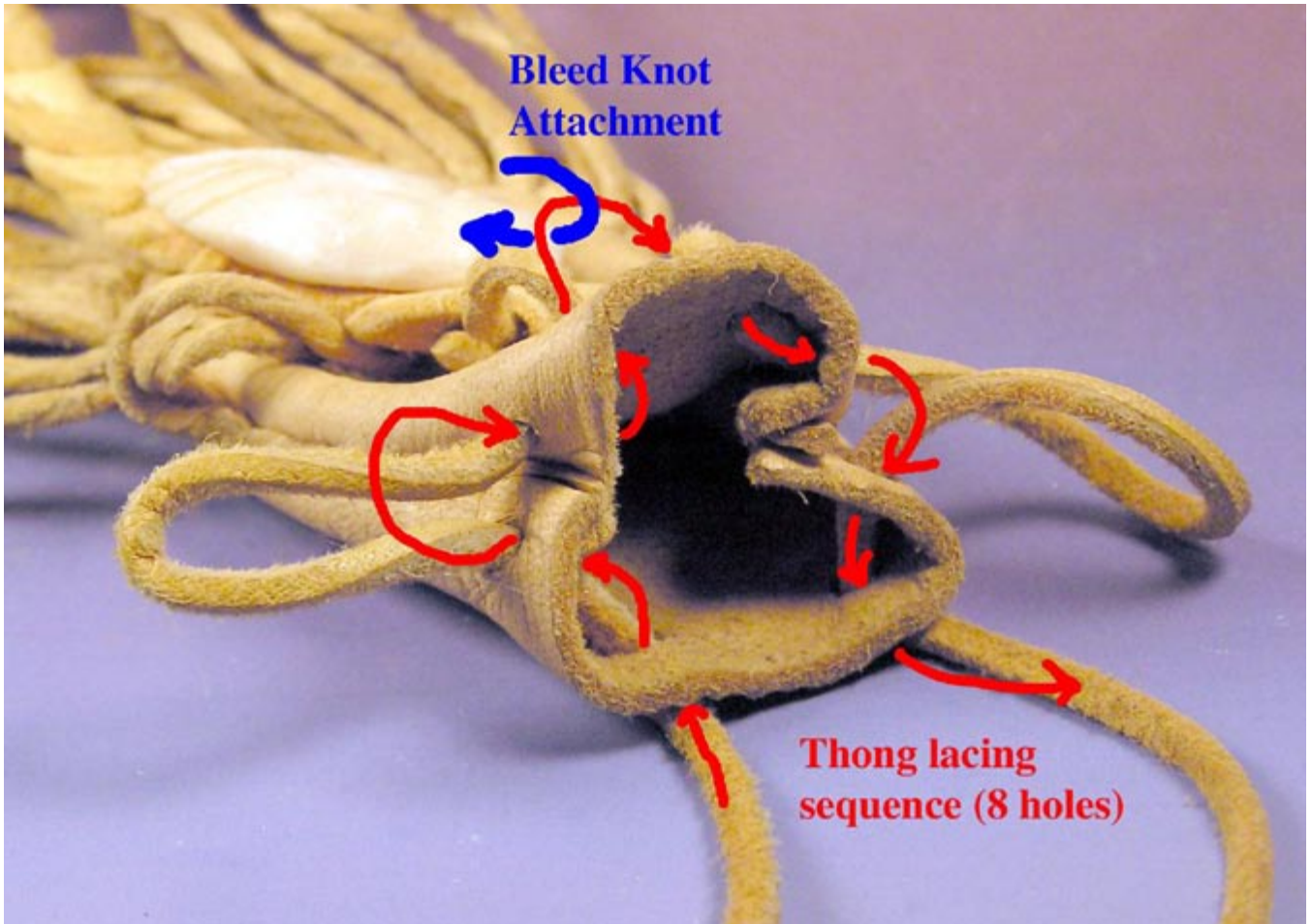

There are 8 thong holes for the pouch closure. If you are going to alter the number of holes, do so with a good bit of forethought. The number of holes is critical if you want the thong to enter and emerge in appropriate places. Above is the lacing sequence for 8 holes. Note the place where the bleed knot is attached to the closure and necklace thong.





Here's how to make the bleed knot. Above is a strip of buckskin, about 5 inches long and tapered on both ends. Any sort of soft leather will work for this. I'm using buckskin so it will match the medicine pouch.



I've folded the strip in half to find the center, and about half an inch down from the center I've punched a hole. You can also make a vertical slit if you don't have a punch like the one shown. Since my buckskin strip is about 1/2 inch wide in the center, I'm using the largest size punch setting.



Now take the end from the half that wasn't punched and feed it through the hole.



Pull it on through until the gap left at the top is the appropriate size. In this case, I want the gap about 1/4 inch in diameter, to attach to the closure thong on the medicine pouch. You make it the right size for your application.



Now punch another hole in the half you just passed through the first hole. The distance from where the strip emerges from the first hole to where you punch is about half the width of the strip at that point. The only thing you can do to mess up the bleed knot is to punch the hole in the wrong half. Remember, the hole is punched in the **OTHER** half, not the half you just punched the hole before. The half you just passed through the hole is the one that receives the next hole. This will alternate all the way along the bleed knot.



Again, take the other tip and pass it through the hole you just punched and pull it up snug. You will probably need to spread the strip out and sort of "fluff" it up in the spot where it emerges from the hole.



Here's what it looks like so far. We've punched two holes and passed the ends through twice.



Now, punch another hole in the half that was just passed through the previous hole. Make sure you get the right half punched.



Pass the other end through, and pull up tight, fluffing as you go.



Here we are with three holes punched, three ends passed through. Continue on as long as you want to. Somewhere along in here, if you plan to add a talisman like I've done on my medicine pouches, you need to pass the end through your carving, then through the next hole. In that case, of course, you'll have had to punch the hole a little farther down because of the carving. I string on the carving and then punch the hole where it's needed.



And here's the finished bleed knot, ready to install on the pouch, or whatever you had in mind. This medicine pouch has a raven talisman, carved in fossil ivory with an inlaid ebony eye installed on a bleed knot. I soaked the ivory in a linseed oil based wood finish to give it that translucent look.



This little medicine pouch has a hummingbird skull talisman, carved out of a piece of moose antler, and the beak carefully darkened with Procion™ dye. I also included a small boxwood slide that slides up both sides of the buckskin neck thong and keeps the pouch closed. I pyrographed a small twisty lizard on the slide. The slide has two carved thong holes at the top corners that merge into one thong hole which comes out at the bottom.

### *Carving Bird Skulls*

Here are some detailed images of the moose antler hummingbird skull. I don't try to make the skull absolutely anatomically correct, just enough to get the idea across.



In the second hummingbird skull image, you can see the two holes I carved so the bleed knot attachment

would pass through, one in the position where the spine would attach, and one just forward of that.



As you have probably surmised, the most important things about bird skulls would be to get the beak the proper shape, and the large eye cavities. Most bird skulls have lots of holes in them, to make them light for flight, but you only want to put in the major ones, otherwise your carving will be very delicate.





Here's a pattern for the hummingbird skull. They are very tiny, this one about 1 1/2 inches long.



We've also found carved bird skulls useful in some of our other art, in this case a moose antler raven skull lid for a tiny basket. Below are some detailed images of the raven skull carving.





Here's a pattern for the raven skull. A full sized one would be about 3 inches long. You make yours to whatever size you want. Remember, accuracy isn't important here, just the artistic effect.



Here's a pattern for a sort of generic pigeon shaped skull. This one about 1 7/8 inches long.

Here's the pattern for the medicine pouch. Made somewhat like the buckskin pouches shown before this section, the medicine pouch has only three major parts. They are a front and back, and a combination welt and fringe piece. This pattern prints out on a single sheet of paper, and uses very little leather.

Welt and fringe  
Need 1 Piece

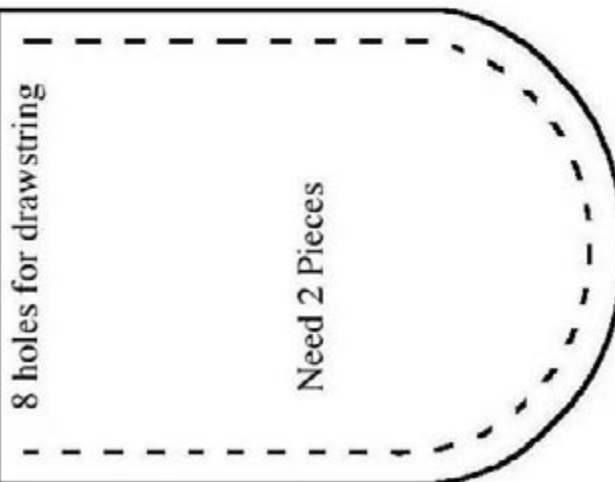

## **How To Identify Different Kinds of Ivory**

U.S. Fish and Wildlife Service, National Fish and Wildlife Forensic Laboratory web site on ivory identification: <http://www.lab.fws.gov/Ivory/>

### **Tools List**

(The items in boldface are the minimum recommended)

#### **Standard Cutters (sizes are approximate, carbide if possible)**

Ball (3/32" shanks) **1/8"** 3/16" **1/16"** **1/32"** and the smallest available

Ball (1/8" shanks) **1/4"**

Flame shaped 1/4"

Oval shaped 1/4"

Inverted cone 1/4" 1/8" 1/16"

Barrel shaped **1/4"**

#### **Structured Carbide Cutters (with 1/8" shanks, sizes are approximate)**

Ball shaped 1/2 " 1/4"

Barrel shaped 1/2 " 1/4"

Bullet Shaped 1/2 " 1/4"

#### **Mandrels**

3/32" or 1/8" shaft (**several of these**)

#### **Brushes**

Fiber brushes (several of these)

Wire brushes (several of these)

#### **Materials**

Abrasive Polyester pads **various types and abrasiveness**

Sandpaper **200 grit (fine)** **220 grit (extra fine)**

Emery paper **As fine as you can obtain (400 - 600 grit)**

Muslin Buffs - several sizes

Felt Buffs - several sizes

#### **Knives**

Scalpel or Hobby Knife (Xacto is one such brand) #3 Handle #11 blades (or equivalents)

#### **Chisels**

Micro Detailing Chisels **1.5mm Set** 2mm Set **3mm Expansion Set**

#### **Engravers**

Diamond cross section small size

**Hairline engraver** small size

#### **Dental Tools**

Hook shaped scraper

Leaf shaped scraper

## **Bibliography and References**

Try your library - you'll be surprised how many books are often available locally. (Library of Congress and International Standard Book catalog numbers and publisher's addresses provided when known for ease of acquisition)

Bushell, Raymond: *The Art of Netsuke Carving by Masatoshi as told to Raymond Bushell*, Kodansha International, Tokyo, New York and 18. San Francisco 1981.

Bushell, Raymond. *Collectors' Netsuke*. New York, Tokyo: John Weatherhill, Inc., First Edition 1971, Fifth Printing 1982. 149 Madison Ave, New York, NY, 10016 Library of Congress Catalog Card No. 70-139687 International Standard Book No. 0-8348-0056-X

Bushell, Raymond: *An Introduction to Netsuke*, Tuttle, Tokyo and Rutland, Vt. 1964.

Bushell, Raymond. *Netsuke, Familiar & Unfamiliar New Principles for Collecting*. New York, Tokyo: John Weatherhill, Inc., 1975. 149 Madison Ave, New York, NY, 10016 Library of Congress Catalog Card No. 75-22420 International Standard Book No. 0-8348-0115-9

Bushell, Raymond: *The Wonderful World of Netsuke*, Tuttle, Tokyo and Vermont, 1964.

Davey, Neil: *Netsuke*, Faber & Faber, London, 1974 in association with Sotheby Parke Bernet Publications.

Hurtig, Bernard (Compiled by). *Masterpieces of Netsuke Art*. New York, Tokyo: John Weatherhill, Inc., First Edition 1973, Third Printing 1980. 149 Madison Ave, New York, NY, 10016 Library of Congress Catalog Card No. 73-3202 International Standard Book No. 0-8348-0085-3

Norbury, Ian. *Techniques for Creative Woodcarving*. New York: Charles Scribner's Sons, 1984. International Standard Book No. 0-684-18210-6

Kinsey, Miriam. *Contemporary Netsuke*. Vermont & Tokyo: Charles E. Tuttle Company, 1977. Library of Congress Catalog Card No. 77-072596 International Standard Book No. 0-8048-1159-8

Kinsey, Miriam. *Living Masters of Netsuke*. New York: Kodansha International/USA Ltd., 1983 First Edition. Distributed through Harper & Row, Publishers Inc., 10 East 53rd St., New York, NY 10022 Library of Congress Catalog Card No. 84-47685 International Standard Book No. 4-7700-1179-2

Kinsey, Robert O: *Ojime: Magical Jewels of Japan*, Abrams, New York, 1991.

Lundy, Robert E. Carving the Historic Western Face. Kalispell: B. J. Enterprises, 1988. 123 Willow Glen Dr. Kalispell, Montana 59901 Library of Congress Catalog Card No. 0-9619094-0-4

Although this book is about carving larger sizes, it is an excellent source of instruction and techniques for carving faces.

O'Brien, Mary Louise: Netsuke: A Guide for Collectors, Tuttle, Tokyo and Rutland, Vermont, 1965

SIMMs, Edwin C. Jr.: Netsuke: Japanese Life and Legend in Miniature, Tuttle, Tokyo and Rutland Vermont, 1991.

### *Contemporary Netsuke Carvers - Web Sites:*

<http://www.sterlingsculptures.com> - my web site

<http://www.janeljacobson.com/index.html> - Janel Jacobson, contemporary netsuke artist, also great collection of netsuke links

<http://www.mammothcarving.4mg.com> - netsuke and small sculpture carving

<http://www.arscives.com/jkelso> - Jim Kelso, contemporary netsuke and awesome Japanese-style metal art

<http://www.forestdeer.ndo.co.uk> - Guy Shaw, contemporary netsuke carver, unfortunately passed away

<http://www.sculpture-intense.com/> - Four contemporary netsuke artists

<http://www.dougsanders.net> - Doug Sanders, contemporary netsuke carver

<http://www.sergeosipov.com/index.html> - Sergey Osipov, contemporary netsuke carver

<http://users.iptelecom.net.ua/~netsuke> - Alexander Derkachenko, contemporary netsuke carver

<http://www.cornelschneider.ch> - Cornel Schneider, contemporary netsuke carver

### *Good Netsuke or Carving Web Sites*

<http://www.thecarvingpath.com> - Carving Forum that welcomes carvers from many disciplines, whose work involves small scale carving. This forum provides a friendly, informative and accessible place for communication and learning.

<http://www.netsuke.org/> - The International Netsuke Society (formerly known as the Netsuke Kenkyukai Society) is devoted to the study and collection of netsuke and related sagemono art forms.

<http://www.cc.rim.or.jp/~komada/> --Information about netsuke-related happenings and events

<http://www.shinenkan.com/> - Contemporary netsuke and Japanese art collection

<http://www.robynbuntin.com/> - Contemporary and antique commercial netsuke site

<http://www.meijiart.se/> - Commercial netsuke site

<http://www.netsuke-inro.com/> - Commercial netsuke site

<http://www.morra-japaneseart.com/> - Commercial netsuke site **SMALL CHILDREN WARNING - EROTIC PRINTS also at this site**

<http://www.slmooss.com/> - Commercial netsuke site

<http://www.theorientalcorner.com/> - Commercial netsuke site

<http://www.orientationsgallery.com/> - Commercial netsuke site

<http://www.netsuke.com/> - Commercial netsuke site

## Sources of Supply

### **Boone Trading Company**

PO Box 669  
562 Coyote Rd  
Brinnon WA 98320  
(360)796-4330 (800)423-1945  
<http://www.boonetrading.com/>  
Excellent source for exotic carving materials like fossil ivory, antler and even items further afield.

### **The Woodcraft Shop**

2724 State Street  
Bettendorf IA 52722  
(800) 397-2278 (563)359-9684 Fax: (563)359-6456  
Larry Yudis, Owner, Carol Yudis, Sales Manager  
General woodcarving supplies and books, micro detail chisels, rotary cutters, etc. Great people to deal with!

### **Wood Carvers Supply, Inc.**

PO. Box 7500  
Englewood FL 34295-7500  
Orders (800) 284-6229  
Questions (813) 698-0123  
FAX (813) 698-0329  
<http://www.woodcarverssupply.com/>  
General woodcarving supplies and books, micro detail chisels, rotary cutters, etc.

### **Micro Mark**

The Small Tool Specialists  
340 Snyder Ave  
Berkeley Heights NJ 07922-1595  
(800) 225-1066  
Small hand and power tools

### **Grobet USA™**

750 Washington Avenue  
Carlstadt, NJ 07072 USA  
Toll Free: (800) 847-4188 (USA only) Phone:  
(201) 939-6700 Fax: (201) 939-5067  
<http://www.grobetusa.com/>  
E-mail: [email@grobetusa.com](mailto:email@grobetusa.com)  
Rotary bits (especially extremely small and unusual shapes) and engravers

### **Dharma Trading Company**

<http://www.dharmatrading.com/>  
PO Box 150916  
San Rafael CA 94915  
(800) 542-5227 (415) 456-7657 (415) 456-8747  
FAX  
Source for Procion Brand Dyes



**For comments or questions, please contact:**

**Thomas Sterling**

**PO Box 1621**

**Coupeville WA 98239**

**netsuke@comcast.net**

**netsuke@sterlingsculptures.com**

### **About This Book**

This book was completely self published using an Apple™ Macintosh dual 800MHz processor G4 PowerPC computer, with Adobe InDesign CS and Adobe Photoshop . Pictures were scanned using an Epson Perfection 1660 color scanner and photography was (mostly) by an Olympus C755 Digital camera. The entire book occupied over 450 megabytes of disk storage, and the InDesign files were more than 170 Megabytes in size. It took more than 2 years to complete, not including the original carvings, and over 11 years from conception to inception for this second edition.